



This is a digital copy of a book that was preserved for generations on library shelves before it was carefully scanned by Google as part of a project to make the world's books discoverable online.

It has survived long enough for the copyright to expire and the book to enter the public domain. A public domain book is one that was never subject to copyright or whose legal copyright term has expired. Whether a book is in the public domain may vary country to country. Public domain books are our gateways to the past, representing a wealth of history, culture and knowledge that's often difficult to discover.

Marks, notations and other marginalia present in the original volume will appear in this file - a reminder of this book's long journey from the publisher to a library and finally to you.

### Usage guidelines

Google is proud to partner with libraries to digitize public domain materials and make them widely accessible. Public domain books belong to the public and we are merely their custodians. Nevertheless, this work is expensive, so in order to keep providing this resource, we have taken steps to prevent abuse by commercial parties, including placing technical restrictions on automated querying.

We also ask that you:

- + *Make non-commercial use of the files* We designed Google Book Search for use by individuals, and we request that you use these files for personal, non-commercial purposes.
- + *Refrain from automated querying* Do not send automated queries of any sort to Google's system: If you are conducting research on machine translation, optical character recognition or other areas where access to a large amount of text is helpful, please contact us. We encourage the use of public domain materials for these purposes and may be able to help.
- + *Maintain attribution* The Google "watermark" you see on each file is essential for informing people about this project and helping them find additional materials through Google Book Search. Please do not remove it.
- + *Keep it legal* Whatever your use, remember that you are responsible for ensuring that what you are doing is legal. Do not assume that just because we believe a book is in the public domain for users in the United States, that the work is also in the public domain for users in other countries. Whether a book is still in copyright varies from country to country, and we can't offer guidance on whether any specific use of any specific book is allowed. Please do not assume that a book's appearance in Google Book Search means it can be used in any manner anywhere in the world. Copyright infringement liability can be quite severe.

### About Google Book Search

Google's mission is to organize the world's information and to make it universally accessible and useful. Google Book Search helps readers discover the world's books while helping authors and publishers reach new audiences. You can search through the full text of this book on the web at <http://books.google.com/>

C 447,246



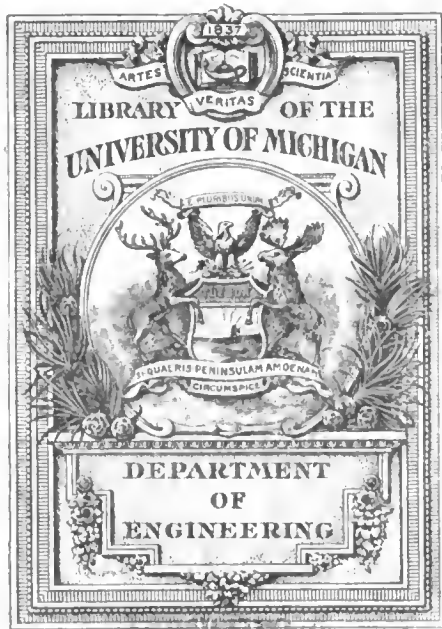

LIBRARY

ENGIN. LIBRARY

TL  
1  
A90







# THE AUTOMOBILE

A JOURNAL OF AUTOMOBILE PROGRESS  
AND  
CONSTRUCTION

PUBLISHED WEEKLY

---

VOLUME XXV

---

July 6 to December 28, 1911

THE CLASS JOURNAL COMPANY

231-241 WEST 39<sup>TH</sup> STREET

NEW YORK CITY

no.



# THE AUTOMOBILE

VOL. XXV

NEW YORK—July 6 to December 28, 1911—CHICAGO

Nos. 1-26

## ACCESSORIES

Acme torsion springs.....	698
Apco license plate on front axle.....	245
Auristophone, automobile.....	165
Ball bearing, H. C. B., a new.....	375
B-A tire lock.....	698
Blowouts, cause of.....	468
Body, shortcomings of the average.....	182
Brown power pumps.....	468
B. & S. ball and throttle joint.....	245
Carbureter, how to study the.....	261
Chains require attention.....	144
Convertible body for depot work.....	348
C. R. G. carbureter.....	650
Cyclone ventilator shield.....	512
Disco self-starter.....	790
Fitting the car to the buyer.....	537
Gasoline economizer and filter.....	286
Grease cup, securely attached.....	286
G. & A. Carbureter, details of.....	822
Hartford Safety Crank.....	164
Heel rest.....	287
Ideal shock-absorber.....	838
Inner-lining, Auto Tire Inner-Lining Co.....	164
Lambert demountable rim.....	790
Limousine, new single compartment.....	490
Lock, B-A tire.....	698
Magneto, coupling to the drive.....	287
Maher duplex multi-spark plug.....	560
Maneco safety lock.....	468
Muffler, the Miller.....	698
Norma bearings.....	512
Painting bodies, new methods of.....	304
Perfect window regulator.....	560
Phelps trouble finder.....	165
Rapid engine cleaner.....	698
Rims, Detroit rust-proof demountable.....	164
Runabout as winter car.....	861
Security blowout patch.....	560
handle for tonneau.....	245
Solderall compound.....	286
Speedo air valve.....	650
Springs, acme torsion.....	698
Star safety starter.....	560
Start-lite illumination.....	838
Tire durability.....	473
sectional emergency.....	287
Treads, center-studded, detachable, non-skid.....	149
Tuto electric horn.....	468
Wright spark plug.....	838

## ASSOCIATIONS AND CLUBS

Accessory organization grows.....	688
A. A. A. annual meeting.....	1013
A. B. of T. committees named, new.....	641
six new members of.....	783
A. C. A., President Taft to be guest of.....	828
Annual meeting S. A. E. at Dayton.....	22
Big Village Motor Boosters' picnic.....	326
Chicago dealers' open-house week.....	438
Coffin addresses British engineers.....	917
Delaware Club's annual banquet.....	895
French clubs resume race control.....	782
Kansas City Motor Car Dealers' Association.....	685
formed.....	940
L. I. A. C. banquet.....	915
to hold contest.....	915
Maryland Club watches streets.....	915
M. C. A. clears sporting skies.....	275
M. C. A.'s most important meeting.....	235
Manufacturers' Contest Association meets.....	115
N. A. A. M. members, new.....	463
Newark Club plans for new home.....	39
S. A. E. adopts standard solid tires.....	321
aluminum castings.....	25
Arthur Ludlow's speech at banquet.....	27
carbureter division, report of.....	26
delegates sail for England.....	781
flywheels, steel, standardization of.....	24
headquarters in London.....	733
how worked at Dayton.....	22
lock washer sizes, reducing number of.....	25
long addendum gears.....	25
magneto standards, discussing.....	23
oversize piston standards.....	25

party ready to sail home.....	965
prepares for active winter.....	438
sheet metals discussion.....	23
shows remarkable growth.....	1147
spark plugs, tolerance of.....	24
springs division discussion.....	23
steel flywheels, standardizing.....	24
tour abroad.....	549
tourists now on British trip.....	966
uniform gear shift position.....	24
visits French factories.....	1014
visit is gaining.....	687
Schbimpf succeeds Butler.....	777
T. C. A. scouts arrive at Richmond.....	828

## CAR DESCRIPTIONS

American "30," concerning the.....	174
Bergdoll adds a forty.....	1128
Cadillac characteristics, 1912.....	666
Chase three-thousand pound wagon on market.....	243
Columbia out with Knight motor.....	13
Electric products, some recent.....	354
Franklin omits auxiliary exhaust.....	214
G. J. G. unit power plant a feature.....	1001
Kissel-Kar, details of the latest.....	310
Knox adopts long stroke.....	898
Krit line, few changes in the 1912.....	1042
Lipman new "Six" makes its debut.....	205
Locomobile, refinements of 1912.....	456
Marmon "Thirty-two".....	135
Merced Thirty-five in detail.....	492
Metz, few changes for 1912.....	902
Mitchell motor, explaining.....	810
National construction, details of.....	534
Overland 1912, four chassis types.....	714
Pierce-Arrow, 1912 models.....	452
Premier, Series M.....	758
Rambler refinements.....	671
Rapid trucks, simplicity an objective point in.....	243
1912.....	242
Republic car, an Ohio product, the new.....	854
Selden, refinements for 1912.....	624
Speedwell, specifications of the.....	3
Stearns-Knight motor introduced.....	216
Stevens-Duryea, six-cylinder.....	317
Stoddard-Dayton at close quarters.....	314
line, six-cylinder Knight features.....	254
Warren-Detroit models.....	254

## COMMERCIAL

Armedler enters automobile field.....	161
Britiab makers, passenger business of, falling.....	80
off.....	476
Chicago truck run.....	322
truck run finished.....	523
truck run, lessons drawn from.....	522
truck run, 20 clean scores in.....	482
Detroit trade booming.....	379
Fire apparatus, motorizing Gotham's.....	526
chiefs see apparatus tested at Milwaukee.....	157
engines, motor, in New York.....	461
equipment, Grand Rapids' motor.....	52
French truck becoming popular, new.....	90
Fuel costs in truck operation, what.....	205
General Motors Truck Company forms.....	365
Gimbel buys trucks.....	161
Haver's plant to be enlarged.....	372
Hoosiers seek modern fire apparatus.....	1019
Horseless fire house for Hoosiers.....	484
Indianapolis seeks city automobiles.....	284
Knox water tower tried out.....	484
Lansing auto fire apparatus.....	204
Locomobile fire wagon for White Plains.....	875
Longest oil truck.....	686
Mack-Saurer combine completed.....	479
Mais Co., new officials.....	479
Moline factory doubled.....	809
Motor wagons for military use.....	43
New electric in the field.....	117
Patrol wagon, cost of South Bend auto.....	689
Power wagons, introduction of.....	482

Pullman builds taxi.....	35
Relation of engineer to purchaser.....	484
Reo plans big output.....	710
San Francisco, new winners on revision.....	553
Saurer and Mack companies combine.....	686
-Mack combine completed.....	205
truck reaches New York.....	940
Self-starting truck.....	551
Service cars at Municipal Congress.....	117
South Bend auto patrol wagon, cost of.....	414
Transcontinental Packard truck arrive.....	90
Truck operation, what fuel costs in.....	167
what it costs to run a.....	918
Trucks in mail service.....	285
take place of wagon train.....	285

## CONTESTS

Alco rests on its laurels.....	460
Amarillo, record crowd at.....	415
Bedford climb, Flanders stars at.....	642
Benz, Fairmount winner, Bergdoll in.....	603
Bergdoll in Benz, Fairmount winner.....	371
Boston figures on races.....	40
Brighton Beach two-day meet a success.....	413
24-hour race announced.....	115
Beach 24-hour race postponed.....	370
Beach, two-day meet.....	384
world's records fall at.....	161
Buffalo Club run.....	412
run, seventeen start in.....	483
Brooklands-Sunbeam test.....	370
tour, thirty in.....	662
California tests commercial cars.....	241
Carbureter makers offer prizes.....	478
Chalmers owners consistency tour.....	552
Charter Oak Park meet at Hartford.....	437
Chicago contest happenings.....	798
Motor Club Reliability.....	160
Motor Club, Two-day Reliability.....	778
run, many clean scores in.....	713
run, seventeen entries.....	235
run to be eight-day affair.....	386
six-day, preparing for.....	476
truck run.....	322
truck run finished.....	523
truck run, lessons drawn from.....	280
truck run, seven still perfect.....	522
truck run, 20 clean scores in.....	199
Cincinnati climb, Nationals win at.....	280
four road races at.....	118
Cleveland reliability starts in heavy rain.....	160
run, clean scores in.....	638
Colby star performer at Omaha.....	280
Columbus to see 200-mile race.....	413
200-mile, Westcott wins.....	365
winner to have fine cup.....	662
Commercial cars, California tests.....	642
Danbury meet, bad weather kills.....	79
Dead Horse climb, arrangements completed.....	199
for.....	239
hill climb, August 12.....	437
climb next.....	685
Denver Chalmers owners' consistency tour.....	686
-New York tour sanctioned.....	783
reliability a success.....	665
Desert race, 550-mile across.....	37
Detroit conducts sociability run.....	294
Dirt tracks, fate of in balance.....	198
Elgin, all eyes turn toward.....	363
races, big fields in.....	284
races, progress shown in.....	117
clans gather for.....	333
races, seventeen entries so far for.....	755
stock races, records fall at.....	1018
Endurance, American wins long run.....	749
Evansville Club stages climb.....	478
Fairmount, money lost on.....	324
Park race.....	552
Park race, blanks out for.....	116
Park race, preparing for.....	1149
Park race, Quakers in row with Mayor.....	1079
over.....	603
Quers ask for Fairmount date.....	603
race, protest against.....	603
winner, Bergdoll in Benz.....	603

# THE AUTOMOBILE

Farmers' sociability run.....	414
Fern Bank, Cole and Fiat feature.....	432
good fields in.....	370
Flanders cars break records.....	853
French Glidden, Fords in.....	782
Grand Prix, entries for.....	852
Grand Prix, entries in the 1912 French.....	1149
Grand Prix, Fiat wins.....	160
Grand Prix, reflections of the.....	202
Gaillon hill climb.....	664
Galveston, fast racing at.....	236
Gearhart Beach, small fields at.....	414
Georgia State tour has 50 entries.....	919
tour a hard ride.....	1016
tour a success.....	940
Georgians to tour State and see races.....	525
Glidden changes, ask for.....	411
cleven entries for.....	161
fourteen clean scores in.....	750
has 50 entries.....	505
has 61 entries.....	552
only stock cars in.....	370
only two teams perfect in.....	651
pathfinder en route South.....	438
score enter.....	327
to be good roads tour.....	205
to be won by team work.....	241
twenty-three car teams in.....	641
Grand prize and Vanderbilt races, Savannah gets.....	115
course under harrow.....	238
Fiat Bruce-Brown wins.....	979
looms in near prospect.....	756
Grand Prix, boycott for 1912 French.....	1079
rules for the French.....	1078
Guttenberg races.....	158
races to be run July 22.....	115
Hamline, fast time at.....	435
Harrisburg, Hudson & Cadillac win.....	853
Hartford to have road meet.....	370
races.....	484
races, rain kills.....	437
Hughes makes explanation.....	239
Indianapolis race, date set for.....	783
Kansas City, see Pickens' band at.....	461
Kline-Kars win at York.....	988
Lake Tabor run, six forfeit in.....	373
Long Island Club sealed handicap.....	709
Los Angeles, fast time at.....	708
races sanctioned.....	685
Lowell, Vale; Redivivus, Riverhead.....	79
M. C. A. clears sporting skies.....	275
defines Grade 4 contests.....	463
Making motor trucks stay sold.....	290
Maxwells alone forfeit in Glidden.....	699
Maxwell scores in Lu-Lu's run.....	551
Milwaukee Sentinel trophy, Imperial wins.....	163
Minneapolis, National wins thrice at.....	827
to hold hill climb.....	687
Minnesota winners: Marmon; Flanders.....	203
Missouri A. A. run, five perfect scores in.....	79
Missouri run, Dorris wins.....	324
Mont-Ventoux hill climb.....	281
National breaks world's road mark.....	660
Newark run, thirty-seven perfect in.....	796
Old Orchard, fast time at.....	412
flyers enter.....	370
meet, program for.....	319
no records at.....	431
Oldfield, Lee, held without bail for Syracuse accident.....	552
Omaha run, Ford wins.....	479
seventeen starters in.....	436
Ossining hill climb, National cars sweep card at.....	38
Ostende meeting, the.....	437
Park racing, abolish.....	665
Peoria, world's records broken at.....	687
Philadelphia reliability abandoned.....	827
Phoenix, Pope stars at.....	852
desert race, National wins.....	826
Pickens' band at Kansas City, see.....	461
Point Breeze, fair card at.....	196
Simplex and Cino win at.....	520
Port Jefferson climb, National stars at.....	428
Pottstown, Velie stars at.....	414
Premierites nearing Pacific.....	161
Prince Henry tour, awards in.....	160
Promoters must protect public.....	479
Quaker City Motor Club contest.....	159
Race records of A. A. A.....	941
Racer sues for prize.....	710
Racing season promises activity, 1912.....	1079
Racing circuit planned for Middle West.....	895
put in disrepute by advertising.....	79
season, resume of 1912.....	990
Remy Brassard changes bands again.....	235
successfully defended.....	279
Salem, good racing at.....	412
San Antonio, National wins.....	853
Santa Monica, big entry list for.....	638
Savannah, big purses offered.....	734
card filling.....	825
gets Grand Prize and Vanderbilt races for this year.....	115
races have 54 entries.....	873
races, places and show money in.....	642
speed practice open for 42 cars.....	892
Seranton, records stand at.....	415
Sioux City, fatal accident.....	710
Speedway, new motor.....	505
Sporting events are stirring.....	235
Springfield sees races.....	643
Stanley bill climb.....	161
St. Louis tour starts West.....	280

Success crowns Dead Horse climb.....	267
Syracuse meet.....	474
fatalities mar.....	474
run a success.....	665
track races.....	437
Ten-mile track mark lowered.....	158
Time-run, Long Islanders' secret.....	754
Vanderbilt Cup, Lozier smashes record.....	932
races, Savannah gets Grand Prize and.....	115
Virginia sociability run.....	664
Watson Cup, forty-four in.....	754
White Plains, Election Day races at.....	826
Winnipeg motorists, big month for.....	415
Wisconsin State A. A. run.....	163
tour, protests winner of.....	202
Wishart says he will take an appeal.....	643
Wishart's plea denied by contest board.....	919
World's records broken at Peoria.....	687
road mark, National breaks.....	660

## DIGEST OF FOREIGN PAPERS

Aeroplane improvements, no conspicuous in France.....	767
Bends of road dangerous.....	767
Casehardening department, on the organization of a.....	545
work, defects in.....	628
Celluloid, unflammable imitation.....	1135
Change-speed act, new hydraulic.....	766
Engine efficiency.....	858
Farm implements, motor driven.....	1000
Forced-draft radiator.....	1134
Fused silica for plugs, etc.....	863
Gangplow, motor.....	859
Gasoline solidification.....	863
German construction.....	814
Hardened steel articles, expansion and contraction in.....	544
Hydraulic transmissions.....	998
Ignition, a vigorous.....	815
Italy, market conditions.....	955
Knocking, its causes.....	858
Lock nut, a British improvement.....	862
Lubricating oil burned smokelessly.....	863
Magneto timing, automatic.....	954
Materials for construction.....	499
Metallic machine parts, rules for preservation of.....	815
Motor cultivators, barrows and hoes.....	544
Oxy-gasoline flame for welding.....	1134
Platinum, substitute for.....	721
Quality test for finished parts.....	499
Rain-water drains from tarred roads.....	767
Renault & Hele, show types.....	998
Ruthardt magneto, features of.....	814
Safety cranks.....	906
Safety starting cranks.....	772
Tarred roads, rainwater drains from.....	767
Tools in the motorist's box, useful.....	629
Water tube joint.....	863
Wheels of wire and wood.....	907
Whip as accessory.....	499
Windsfield, wire mesh.....	815

## EDITORIAL

Accessibility, greater, needed.....	410
Accessible car, the.....	916
Annual model idea.....	36
Automobile, the winter.....	462
Backward, turn backward.....	320
Bad roads costly.....	114
Baggage must be carried.....	684
Building assembled-parts automobile.....	234
Burden, the manufacturer's.....	824
Callan law, the stupid.....	114
Clean up New York State.....	320
Comfort is essential.....	640
Delivering the goods.....	234
Does it boast good roads.....	732
Either side, from.....	1060
Elgin races.....	362
Flexibility in drive.....	36
Foreign solution, a.....	872
Freight automobiles.....	156
Get-together spirit, the.....	1146
Grade crossings, apropos of.....	234
Growth of automobile.....	964
Interest in Knight types of motors.....	36
Introducing motor trucks.....	732
Long-stroke motor, the.....	776
Maintenance of good roads.....	114
Metallurgy made easy.....	916
Nobody hurt.....	1012
Non-poppet valves.....	194
Package delivery, automobiles for.....	156
Patent-laws, fallacies in.....	156
Patent litigation, prolific.....	1102
Prevent rather than cure.....	362
Road work, practical.....	504
Roads for automobile and horse.....	156
Shop system, importance of.....	234
Shortcomings of the art.....	194
Shows and contests pay.....	1102
Side levers, insecurely fastened.....	114
Silence, interest in.....	76
Silent motor, the.....	36
Studying salesmanship.....	546
Tell the truth.....	362
Testing automobiles.....	194
Tires, inflation of.....	274
Track racing danger.....	504
Will and the way, the.....	546

## EQUIPMENT

A. A. gas lighter.....	1112
Adulteration bane of good varnish.....	19
Body needs, owners awakening to.....	83-84-85
D. K. W. carburetor.....	1068
Dover gasoline vessels.....	1156
Electric system, matchless.....	122
Ever-Ready automatic starter, the.....	95
Fix tire cement.....	245
Light-lighting system, P. B. automatic.....	123
Matchless electric system.....	122
No-key padlock.....	1068
P. B. automatic light-lighting system.....	123
Safety crank, Perkins' auto.....	123
Self starter, Chalmers has.....	112
-starting devices, novelties in.....	623
Single-button switch.....	1112
Shock absorber idea old.....	312
Starter, the Ever-Ready Automatic.....	95
Tire gauge, Schubert.....	1068
Top, in the fitting of.....	64
Traver patent blowout patch.....	1112
Vanometer gasoline gauge.....	1112
Varnish, good, adulteration bane of.....	19
Windshield adaptations.....	720

## GOOD ROADS

A. A. A. to boost good roads.....	413
Akron starts road building.....	923
Anderson memorial.....	365
Baltimore to buy last toll road.....	365
Bingbam deserts pavement job.....	77
Blue Book cars under way.....	59
crew finds good roads.....	157
Bristol scouts reach Washington.....	642
Canada, oiled roads in.....	139
Chapin, good roads delegate.....	478
"Clean-up day" in New York State.....	324
Congress in Chicago, good roads.....	203
Diller, Neb., helps form club.....	258
Dominion, improving roads of the.....	513
Good roads, keynote of prosperity.....	200
road tourists, routing.....	863
Government instructs in road examination.....	550
Grade crossings, Indianapolis abandons.....	437
Highway experts inspection.....	480
Hoosiers active for good roads.....	371
Harrisburg club to fight bridge tolls.....	1040
Jeff Davis Highway.....	1041
Jersey mayors to abolish deathtraps.....	1103
King's highway, rebuilding of.....	284
Lineoln way prospects.....	1040
Madero urges good roads.....	1017
Montana building inter-park road.....	550
Ocean to ocean highway, plan.....	1148
Oiled roads in Canada.....	139
Oklahoma City shows the way.....	282
Ontario model of road building.....	20
Oscillating valve engine.....	837
Pennsylvania survey roads.....	1148
to spend \$200,000,000 on roads.....	39
Richmond meeting, preparing for.....	713
road congress.....	968
road congress in session.....	919
Road building, as to.....	140
building enterprises, modern.....	683
destroyer, old Dobbin as a.....	125
San Mateo County system.....	1018
South's big road convention, preparing for.....	77
State officials to inspect roads.....	281
T. C. A. road inspection tour.....	513
Texas, planning trans-State highway in.....	116
Toll road abandoned, another.....	1041
Virginia, good roads train to tour.....	116
road, picking out.....	159
Wisconsin adopts State aid.....	283
to build 645 miles of road.....	1149

## IN THE SHOW WINDOW

Adlake license number illuminator.....	47
Air compressor, Jacobson.....	978
Ajax tire trunk.....	124
sliding-door tire trunk.....	332
Almond flexible steel tubing.....	332
Al-Ton car heater.....	378
Argus mirror.....	422
Autokit, Bay State.....	288
Aviator goggles.....	742
Axle, rear, American Ball Bearing Co.....	166
Bison-sparker ignition battery.....	206
Blowpipe, Turner double jet.....	422
Bower roller bearing.....	124
Brown tire gauge.....	124
Buckeye electric drill.....	742
Cinch repair kit.....	1026
Clear vision automatic windshield.....	246
Columbia nut.....	246
Cover rubber goggles.....	82
Crone valve rescuer.....	332
Denegre demountable rim.....	246
Detroit oiler.....	82
Distributor, Leavitt.....	288
Duplex folding pail and strainer.....	332
Eagle whistle.....	378
Edelmann's compressometer.....	422
Eldred battery charging rheostat.....	206
Electric headlight, Columbus.....	378
Gasoline meter, Smith.....	288
Geisler storage battery.....	44
Gray-Hawley autolarm horn.....	332
Gus Balzer tail lamp.....	246
Hart gas-light igniter.....	44
giant tire pump.....	422

# THE AUTOMOBILE

<p>Hawkeye refrigerator basket..... 124  Homo-carburetor..... 246  Indian spark-plug..... 166  Liquid Carbonic Co.'s improved baby gas tank..... 312  Link-belt silent chain..... 246  Lock switch, automatic..... 930  Luxury folding seats..... 206  Machine stand, Haco..... 930  M. &amp; L. tire pump..... 378  Morse portable electric lamp..... 44  National steam vulcanizer..... 124  Neverout radiator heater..... 742  Nielsen's hose connection..... 206  Ornament, Red Cross radiator..... 124  Phinney-Walker keyless clock..... 44  Racine horse-shoe tire..... 166  Read-Rite volt ammeter..... 206  Rector tire power pump..... 82  Red Cross radiator ornament..... 124  Refrigerator basket, Hawkeye..... 124  Roller bearing, Bower..... 124  Safety device, Langrehr..... 882  S. B. R. muffler cut-out..... 44  Self-starter, American..... 978  Simplex gas regulating valve..... 82  Slikup, rubber compound..... 930  Speedometer, Sears-Cross..... 288  Spring, radial, Garden City Works..... 166  Star light illumination..... 1026  tire and tool case..... 422  Sterling time clutch..... 206  Stryker cut-out..... 422  Tachometer..... 288  Tire gauge, Brown..... 124  Torch, gasoline, Turner..... 882  Tri-radiant acetylene burner..... 288  Trunk, Ajax tire..... 124  Typhoon horn..... 378  Universal hydrocarbon gas producer..... 82  joint, Blood Bros. Machine Co..... 166  Vaco bottle..... 378  Vulcanizer, National steam..... 124  Washer, Federal..... 970  Weston volt-ammeter..... 44</p>	<p>Acetone, regarding..... 865  Acetylene gas troubles..... 1004  must be clean..... 816  Air cock on intake..... 539  compressors..... 497  port auxiliary..... 865  Anti-freezing solutions..... 864  Armature to connecting rod, relative positions of..... 227  Automobile improvements..... 446  Average 1911 cars, details of..... 307  Avoiding freezing..... 956  Axle shows signs of sagging..... 68  Baffle plate, put at open end of cylinder..... 68  Ball sockets, method of replacing..... 68  thrust, insert a..... 447  Belt dressing has been used in past..... 69  Boiling, maker will give remedy for..... 28  Brake Adjustment..... 1138  adjustment, locking the..... 394  adjustments made easy..... 69  broken, internal..... 447  Brass, how to darken..... 538  wants to brighten..... 447  Breather pipe, leave open..... 908  Calipers, use a pair of..... 724  Camshaft bushings, how to stop, from turning..... 28  and magneto gears..... 1004  Carbon deposits..... 865  in cylinders..... 446  Carburetor, adjustment of the..... 630  characteristics of the..... 631  fitted new..... 676  pops again..... 817  query about..... 909  troubles..... 724  troubles..... 768  Cars, desires names of..... 394  Casings, valve spring..... 816  Charging storage battery from electric lighting main..... 189  Chauffeurs, fooling prospective..... 267  Clearance, not enough..... 446  Cluh, how to start one..... 1005  Clutch jerks and pounds..... 447  fierce, how to remedy..... 539  jerks on high speed..... 266  leather, how to renew the..... 1094  repairing old..... 817  spring, compressing..... 151  Cooling water, direction of the flow of..... 1053  Compression, loss of..... 1095  Crankcase explosions, has..... 1094  Coil, trouble with the..... 109  Combination tool, wants..... 446  Compression, measuring..... 496  space, measuring..... 676  troubles, has..... 109  Cone clutch, in trouble with a hitting..... 188  Cracked water jacket, smooth on for..... 68  Crankcase drains, how to open..... 539  Cranking motor, left hand should be used for..... 29  Crankshaft, repair broken..... 768  welding, an unpromising undertaking..... 68  Creaking, linseed oil will prevent..... 28  Critical speed, bow to find..... 29  Crowded roads, deprecates..... 676  Coupling with solder, coat the driving faces of the..... 109  Cut-out assist motor at low speeds? Does..... 227  Cutting oil grooves in connecting rod brass..... 226  Cylinder, a knock in the..... 109  Cylinders, carbon in..... 446  Darkening brass..... 350  Differential, unconventional type..... 267  Drain cock, fitting of..... 394  E-M-F gear ratio..... 29  Eliminating gear change lever..... 677  Engine design, concerning..... 630  loses power..... 538  ratings..... 1005  vibrates..... 446  Exhaust valve, open a little earlier..... 28  Farm motors, information on..... 768  Float, carburetor, "waterlogged"..... 497  Flooded carburetor due to punctured float..... 226  Flywheel fan, description of..... 306  wants heavier..... 769  Ford cars, pointers on..... 1052  Ford headlights, Re..... 1139  Franklin engine, wants information on..... 68  French automobile literature..... 189  Front tires, wear of..... 1095  Gasoline information..... 768  tank piping..... 351  Gear ratio, E-M-F..... 29  Gear-shifting device, a new..... 677  Gearshift lever works loose..... 189  Geometric curves..... 307  Getting out of ruts, handy way of..... 226  Gordon Bennett cup races, when were held..... 68  Holding down cap..... 496  Horses vs. motor trucks..... 1004  Horsepower rating of a motor..... 1053  Ignition, jump spark..... 816  wire attachment, simple..... 29  Improper material condemned..... 351  Increased power of engine 30 per cent..... 266  Indianapolis race information hard to get..... 28  Information, variety of..... 496  Intake line, screen in the..... 395  Internal brake broken..... 447  Jackshaft, method of withdrawing..... 68  Kerosene as fuel..... 909  in radiator..... 768</p>	<p>Key as strong as two, one..... 226  Kick, an unexpected..... 395  Knock in the cylinder, a..... 109  Laying up the car..... 1005  Lifting a motor..... 351  Loose bearing hushing..... 538  Lubrication problem, Duryea has last word..... 306  situation, another view of the..... 108  Magneto, advantage of high-tension over low-tension..... 539  and storage battery may be used together..... 677  test with bell..... 908  Marine motor design..... 151  Mercer car? what make of motor in..... 69  Misfire, elusive..... 909  Misfiring cylinder, detaching a..... 631  due to several causes..... 817  Misses fire at speed..... 908  Mixture too rich..... 864  Mohair tops..... 724  tops, dressing for..... 394  Motor, running the, upside down..... 394  V-shape..... 150  Motor, belittles new..... 1095  Mud guard, needs..... 676  Muffler, trying to blow up the..... 188  Mysterious rattle under car..... 266  Needle valve, a leaky..... 395  Patch tight, holding repair..... 1052  Patebec has trouble with..... 1094  Piston displacement, finding the..... 1052  Qui sait?..... 1138  Regarding magneto and freezing water..... 1138  Repairman, tips from a..... 1138  Second-hand car, what is a..... 1139  Self-starters, is interested in..... 1095  Starter, compressed air..... 1139  Starting on the spark, as to..... 1053  Stuck, radiator cap..... 1139  Tire facts, wants..... 1138  Treating ties for the winter..... 1053  Trouble with single cylinder, has..... 1139  Valve information, some..... 1094  Worthy cause, a..... 1095  Non-freezing solution..... 724  Nut locking device..... 1004  Oil, excess, how to prevent..... 539  flow of, must be watched..... 816  leaks from crankcase..... 497  level gauge on crankcase..... 266  motor does not get enough..... 307  uses too much..... 725  Oiler, mechanical, adjustment..... 816  Opinions of outsider on trade situation..... 395  Painting automobile..... 150  Piston clearance..... 350  removing and replacing..... 188  ring sticks..... 447  rings worn..... 909  Planetary to selective gear, changing from..... 226  Power and valve timing..... 631  Preparations for a long tour, making..... 188  Protecting tire valve stems from blowouts..... 226  Puncture-Proof Tire..... 447  Putting in a new wrist pin and bushing..... 189  Radiator leaks, testing for..... 724  Radiators, rust in..... 957  Rear axle, what make of..... 69  Reflectors, cleaning of..... 864  Repairman necessary, a trip to the..... 188  Reverse ratio..... 908  understands everything except..... 227  Rim motion, jerky..... 446  Rotary engine..... 956  Rubber is porous..... 446  Scavenger, vanadium as a..... 769  Scavenging problem, interest centers in..... 29  scoop, oil, not necessary..... 497  Score board illustration..... 725  Screws, removing broken..... 677  Shaft keys, designing of..... 307  Sight holes in windshield..... 307  Sleeve-valve motors..... 151  Slide valve, likes the..... 677  Small cylinder design..... 350  Solder, coat the driving faces of the coupling with..... 109  Soldering aluminum..... 394  information..... 957  Spark apertures—testing..... 768  plug too short..... 447  Starting handle, a new..... 306  Steering knuckle..... 496  Storage battery and magneto may be used together..... 677  Storing cars in barns..... 865  Strainer and cover on oil tank..... 267  Tesla's motor questioned..... 956  Throttle valve, hole in..... 538  Tight wheels, removing of..... 865  Timing, marking flywheel for..... 394  wants information on..... 109  Tire, examining a leaky..... 631  information wanted..... 267  pinching, to prevent..... 150  pointers..... 1004  puncture-proof..... 447  Tires, use of carbonic acid gas in..... 677  Too much heat, another case of..... 69  Tools, convenient position for..... 28  examine before starting..... 771  Transmission gears, slashing of..... 957  wants article on..... 725  Turnbuckles, lacking..... 768  Universal joint losses..... 1004</p>
<p><b>LEGAL AND LEGISLATIVE</b></p>		
<p>Acme Company almost won..... 1017  Alabama law to be fought..... 734  Allen suit proceeds..... 1061  American Fidelity vs. Iowa..... 484  Autolighter Co. asks injunction..... 1017  Auto lighter sues on patents..... 1077  A. L. A. M. to undergo a court test..... 1077  Bonds, Oklahoma to vote on..... 783  Colors for public cabs, compulsory..... 1089  Daimler levies on exhibits..... 1017  Drivers, licensing of..... 792  English taxi chauffeurs not workmen..... 349  Electric Storage Battery Company wins..... 1077  Equipment demanded by statute..... 793  France to change its rule of the road..... 259  Free entry for foreign racers..... 940  Garages, how New York will regulate..... 711  Hupp, R. C., seeks to enjoin..... 479  Inconsistencies in auto laws..... 791  Jersey working for same law, all..... 1103  Jersey kills eight-day permits..... 157  motorists for good law..... 895  Chinese wall finished..... 247  Klaxon enjoins rubber company..... 1119  fails to restrain Newton..... 1076  suit filed, another..... 1061  Knight sues Argyll..... 873  Koebler suit against E-M-F halted..... 1061  Legal contemplation, chauffeurs in the..... 794  License right, to test..... 463  law, Maryland seeks to amend..... 551  Maryland chief asks change in..... 1149  Maryland motorists must go for tags..... 1074  Michelin sued by rubber sellers..... 965  Michigan law to be sharply tested..... 1103  Morgan &amp; Wright vs. Republic Rubber..... 783  Motor laws in New Brunswick..... 85  Mud-splashing omnibuses..... 251  Mud splashing..... 1093  National wins its axle suit..... 1061  New Brunswick, motor laws in..... 85  New York court miscellany..... 895  speed law, nobody knows the..... 235  Non-residents, rights and duties of..... 793  Norwalk Co., settling affairs..... 482  Numbers, license, in Kentucky..... 484  Oiling streets, city sued for..... 481  Patent laws may affect industry..... 1076  Penalties for breaking laws..... 795  Rajah company wins action..... 1061  Reciprocity, Jersey men moving for..... 324  Registration and fees..... 792  Republic Rubber vs. Morgan &amp; Wright..... 783  Rubber contract in Federal court..... 1017  Spark plug suits..... 1076  Speed limits of States..... 794  Standardizing signals..... 55  Streator, composition proposed for..... 777  Tire-solid patent in Federal court..... 965  Victor creditors to get Xmas present..... 1077  Weed chain gets six more injunctions..... 1077  chain patent upheld..... 205  chain wins again..... 873  chain wins in Supreme court..... 1017  Wisconsin's new law goes into effect Aug. 1..... 120  Zust debts may be compounded..... 1077</p>	<p><b>LETTERS ANSWERED AND DISCUSSED</b></p> <p>A. L. A. M. formula..... 909  Accessibility, believes in..... 496</p>	

# THE AUTOMOBILE

Valve action trouble with stem, broken	769
Valves, worn, adjusting	908
Varied information sought	351
Wear, points of	677
Wedging up car	497
Wheels not parallel	351
Wiring diagram	769

## LITTLE BITS OF MOTOR WISDOM

Bearings cool, keeping the long necessary to watch	633
Body, cushioning the	867
Bolt and screw heads	501
Bolts and nuts, troubles with	451
Brakes internal expanding	911
Breather pipes must be kept clear	866
Cam actions	958
Carburetors blamed without cause	352
Chipping hammers	399
Chains tear tires, non-skid	541
Clearance in per cent, calculating	726
Clutch, its requirement	308
Cone clutch	867
Connections, making electric	1007
Cooling water, temperature of	680
Crankcase, putting oil in	867
Cylinders requiring reboring	352
Demagnetization required, rapid	450
Differential housings, how cleaned	681
Dogs much used	959
Dowel pin, use of	910
Exhaust manifold, loose	450
Files, cleaning	450
Firing at correct time	771
sequence, six cylinder	818
Flame propagation	541
Forge is of use	399
Gaskets, replacing	1006
Gears, worn and loose	819
Gear pump, the	1007
Glue, when heating	541
Gravity feed, leak in	501
Hacksaw, use of	353
Hammers for special work	726
Horsepower ratings	867
Hose connections often careless	1054
Induction coil	398
Inspection necessary, methodical	500
Joints, inspect universal	451
Key, use of	681
Keyway, one sufficient to hold shaft	540
Kink in lever	309
Leaks, caused by weak mixture	353
Lever	819
Lubricating systems	353
Magneto current, direction of, alternates	1140
Nut locking devices	309
Oil cans, how carried	910
Overlooking the car	959
Pin, extracting a	866
use of dowel	681
Pipe bender useful	450
Piston rings	1007
Pliers	1006
Portable filter for touring	911
Priming cups	309
Reboring, cylinders require	352
Removing gears from shafts	450
Roller bearings, when using	1006
Scavenging cylinders	398
Short circuits	1008
Soldering for amateurs	540
Soldering jobs, small	1096
Spanner, face	450
Spark plugs, care in fitting	501
plugs must be of correct length	308
Splash system well designed	352
Spring lubrication	633
Springs must be carefully fastened	632
Springs, repair of broken	1054
Starting on the spark is poor practice	633
Threaded pieces, measuring	770
Timing correct	541
correct value	399
Tire pump	960
Tire, to select the right size of	451
Tires on the road, care of	680
Rust an enemy of	958
use of old casings	1008
Tongs, full supply required	818
Tools for test work	866
Tools, tempering of	1096
Trembler points out of line	540
Underinflation a cause of trouble	1097
Valve is disabled, when a stems, adjusting	727
Valves, ball check, much used	632
care in grinding of	309
Vapor air will hold at 32° Fahrenheit, weight of	819
Voltage at battery terminals	451
Welding acetylene	501
Wiring slowly	399
Wrench, allegator spanner	958

## MEETING RECURRING TROUBLES

Adjustable spanner a handy tool	228
Altering motor compression	191

Anvil for garage use	191
Butterfly valve	268
Carburetor, the real	191
Centrifugal pump, oiling of	269
Clamp, a tool of great utility	269
Drainage troubles	269
Electric generators, types of	229
Electromagnetic problems	190
Fuel economy in high velocities	229
Garage from burning, keep the	228
Gears and pinions must be durable	268
Generator, the separately excited	229
Hose rack, where to keep the	228
Hydrocarbons, distinction in vaporization of	190
Latent heat of evaporation of gasoline	229
Piston rings, way to pull out	268
Producer gas, composition of	191
Removing carbon from cylinders	269
piston rings	268
Sheet metal joints	268
Stuffing boxes, care of	268
Temperatures in gasoline, initial and final	228
Tire pressures and flexures	268
Torch, get a good-sized	228

## MISCELLANEOUS

Acetylene lamps in winter	485
lamps, points on	67
Akron growing rapidly	825
Alco truck as aid to Santa Claus	1118
Aluminum, increased use of	717
Announcements, 1912, plentiful in Detroit	78
Apparatus, new fire-fighting	91
Atlanta's Automobile Row is growing	553
Audels' answers on automobiles	673
Automobile might have altered map	1027
Automobile incorporations, 374, 419, 465, 509, 557, 647, 695, 739, 787, 835, 879, 927, 975, 1023, 1065	1109
Automobile in many lands	718
new use for the	120
opens new territory, the	231
Aviation language, honorary kinks in	1137
Axle plant enlarged	285
Baggage problem, subduing the	656
Barnes to sell steel castings	203
Bay State Association's annual banquet	1037
Beer and chauffeurs in London	113
Board of trade will work for good of membership	77
Book reviews	870
Boy drivers, Milwaukee after	827
Brick for pavement, discussing	106
Briscoe predicts 210,000 cars for 1912	281
British army taking up motor transportation	105
Models, review of 1912	774
British favor low-power cars	1087
British motor imports increasing	1089
Buses, nine in London	859
Butler killed in Gliddon	733
Sam'l M., last rites for	777
Cadillac self-starter, Detroit news	364
Camping car for du Pont	372
Canada's carriage makers turn to the automobile	185
Canadian experts	33
Cape Breton, automobiles in	90
Car strike, automobile eases vigor of	553
Care on country roads a necessity	257
Case company to change form of name	1118
Census figures	873
Chicago Orphans' Outing	116
Commer truck on missionary trip	243
Croxton sales dept., heads	204
Dealers' week in Detroit	430
Denver electric parade	686
Des Moines as an automobile center, booming	117
Details of construction, attention to	143
Detroit building operations brisk	688
dealers' week in	430
factory, news of	1118
in news of week	1019
in week's news	643
news of week	735
optimism in industry at	831
plants to increase yield	240
the weeks' doings in	121
Dorian sales force reorganized	121
Dupuy, death of Georges	1118
East Africa, government car service in	55
Electric cars, traction company selling	1037
Electricity for the man who wants to know	121
Elements of machine work, text book of the	673
Everitt and Oakland, new homes for	461
banqueted	1019
Exportation, difficulties attending	253
Factory practice, electric drive in modern automobile	230
Fairs, automobile a feature of	431
Fol Company, receiver for	285
Furn uses, adapting the motor to	674
Federal Rubber Co.'s Chicago Branch, Stephens heads	121
Fire board working hard, special departments, steam vs. gasoline in	18
-fighting apparatus, new	91
-fighting, reducing time in	813
in Boston, big garage	436
Firestone moves into new factory	373
Ford company cuts giant melon	1075
Foreign lands, items from	211
Franklin workers enjoy picnic	204
Freehold Motor Co., new garage	163

Garage in Freehold, splendid	241
General motors, list of holdings	411
reports good year	918
German tire guarantees	187
Goggles, light and sanitary	123
Grade crossings a prime nuisance	107
Thompson Ave.	157
Gravity feed, leak in	353
Greensboro, N. C., Automobile Club organized	437
Grinnell electric, to double output of	1075
Halladay tangle, straightening out	549
Harking back a decade	313, 373, 443, 498, 533, 629, 719, 765, 815, 871, 907, 953, 1000, 1049, 1091, 1133
Henderson, Vice-President, honored	79
Hills, climbing slippery	98
Honest penny, how car owners may turn an	67
Honesty best in end	761
Hoosiers raise license rates	1123
Horse 'bus, London's, thing of past	795
Hot weather tip	55
Hupp announces new touring car	1075
Hupp, R. C., replies to injunction bill	553
sells stock in motor company	281
Ideas sketched at Berlin, new	1099
Imported cars, new company to handle	1075
Industry, of interest to the	330, 376, 420, 466, 558, 648, 696, 740, 788, 836, 880, 928, 976, 1024, 1066, 1110, 1154
Inspection, careful, will repay owner	502
Iowa floral parade	371
Iowans visit manufacturers' plants	436
Italian production, statistics of	813
It stands to reason	34, 55, 102, 144, 177, 225
Jersey farmer helps	325
trade seeks open door	204
Johnson dead, Prof. Warren S.	1036
Kaiser's motor car fleet	52
Knight, Charles Y., a guest of his associates	547
Krueger to make electric	243
Leland succeeds Henderson on A. B. of T.	77
Lincoln sees floral parade	734
Long Branch parades	279
Lozier to put out big truck	1075
Maps for air travel	72
Makers are doing to buyers, what	1080
Mason Company to make motors	84
Matheson cars, will sell	285
Mead temporarily heads general motors	284
Mexico doubles imports of automobiles	861
Military use, motor wagons for	809
Miller Rubber Company enters tire field	373
Milwaukee Automobile Club's Orphans' Day	437
Missouri licenses to come down	43
Mitchell agents prepare campaign	285
Montreal longs for more speed	372
Motor Accessory Manufacturers' Board meets	77
Motorette may be reorganized	1075
Muddy weather trip, a	409
My ideal car	396, 397, 448, 498, 542, 634, 678, 729, 773, 820, 868, 913, 961, 1009, 1057, 1062, 1098, 1106, 1142, 1150
Napthalene investigated by government	873
News, late general and trade	1037
News of the week condensed	328, 374, 418, 464, 506, 554, 644, 692, 730, 784, 832, 877, 924, 472, 1020, 1062, 1106, 1150
Non-freezing mixture of denatured alcohol	901
Novel motor wagon load	273
Oakland and Everitt, New Homes for	461
Painting, quick methods of car	622
Pavement, discussing brick for	106
Peeps thro' goggles at distant lands	263, 439
Power plant for a country house	140
Principles of machine work, text book of	673
Quaker dealers elect new officers	1037
Questions and answers for automobile students and mechanics	673
Radiator, in the making of a	806
Registrations, Ohio second in automobile	116
Reiss Co. to move north on Row	461
Repairs, charging for unordered	59
systematic handling of	730
system facilitates	952
Reserve parts stock system	1124
Repair shops, handling of accessories	914
Rubber, removing odor from	963
crude holds at lower level	365
industry of Mexico	723
revolution promised, a	669
Salon, a score of exhibitors at the	1105
Selecting an automobile	356
Senator company ready to start	205
Service, more for Ford owners	390
Showroom, psychology of the	469
Six cylinder motor, first company to make	69
South, hazing the way to the	115
Speedway, new motor	505
Speedwell truck convention	1075
Sprinkling, London, Ont., street	102
Standard Electric Vehicle Co. enters field	243
Steam vs. gasoline in fire departments	18
Stearns service building opened in New York	971
Stevens-Duryca, White-side heads	195
Stopping car, proper place for	27
the car quickly	134
Storage of car, Winter	672
Strike, automobile scores in British	460
Studebaker Co., new heads of	1118
Studebaker dealers, annual round up of	411
Stutz busy producing racing duplicates	79
Subsidy for automobile in Europe	861
Syracuse Club host to orphans	203
T. C. A. double transcontinental trip	1061
Tarif, Canadian on cars	139
Three cents a mile for car operation	1089



# THE AUTOMOBILE

Timken force, Doyle joins the.....	117	dimming device, W. A. Greenlaw.....	697	N. A. A. M., rules for twelfth annual.....	157
Tinkering on the road.....	132	Lifting-Jack, H. A. Schatz.....	697	show.....	685
Tire industry increasing.....	918	jack, Hale.....	881	shows at Chicago, the.....	616
makers busy with orders.....	783	jack.....	467	shows, the list of exhibitors.....	926
situation in Gt. Britain.....	485	Light projector, Churchill.....	649	New York, M. & A. M., program.....	989
troubles, strong desire to get out of.....	108	Liquid fuel engine, Riegals.....	881	preparation for show season.....	874
Toll gate doomed, Baltimore's last.....	437	Loomis ignition system.....	1155	shows overlap.....	115
Transoceanic balloon finished.....	365	Nichold's friction clutch.....	1111	Ohio farmers inspect models.....	371
Transportation, British Army taking up motor	105	Nut lock, Nielson's.....	331	Olympia, many new features at.....	839
Turning a curve.....	360	Odometer, Littleton's.....	559	show offers promising outlook.....	781
U. M. parts form component companies.....	204	Jones.....	741	mechanical notes on.....	883
U. S. Motors netted \$2,040,256.....	1075	Veeder's.....	377	Omaha show Feb. 19-24.....	874
Universal Truck Co. reported sold.....	1075	Oil can.....	511	Omaha's show ideas expanding.....	830
Used-car scheme, Cincinnati dealers'.....	553	Pipe joint.....	837	Palace an architectural gem, new.....	612
cars, how Chicago sells.....	875	Piston ring, Davis.....	649	electrics at the.....	642
car situation sized up.....	869	Pneumatic tire rim, Force.....	649	Paris revives show idea.....	1015
Velic officials entertain dealers.....	734	vehicle cushion.....	559	Philadelphia, change of plans at.....	1105
Wagner to drive a Fiat.....	686	Post turnhuckle.....	1155	Philadelphia show spaces allotted.....	1032
War automobiles, Italy and Austria using.....	1030	Radiator.....	511	Philadelphia show arrangements.....	830
War automobiles arrive.....	161	Clare.....	1025	Pittsburgh show company leases exposition.....	874
Warner Mfg. Co., new plant finished.....	81	Rector tire inflater.....	1155	Providence show Jan. 22-27.....	874
Westcott sales, Shiland takes hold of.....	285	Resilient vehicle.....	421	Quakers to show amid splendors.....	1121
When judgment whispers don't.....	32, 66, 99,	Robertson appliance.....	1111	Rhode Island show in Palm Garden.....	1120
	134, 185, 220,	Roller hearing, Upton's.....	559	Rubber show in 1912, International.....	1033
	262	Rosenfeld taillamp.....	1067	Rochester space all disposed of.....	1033
Whipple suddenly stricken, H. W.....	1147	Rotary engine.....	837	Scranton prepares for show.....	874
Whiteside heads Stevens-Duryea.....	195	Rubber sheeting machine, Mellinger.....	929	Shows, all motordom awaits the.....	1031
Wilby reaches Chicago.....	460	tire, Gillette.....	649	Shows, news of other local.....	1036
Wilson heads American Mfg. Co.....	688	Running-gear, D. M. Dearing.....	697	Show at Canadian capital.....	1122
Winter driving, comfort in.....	743	gear, Meany.....	741	committee to hold meeting.....	235
storage of car.....	672	Sand-distributing vehicle, Huber's.....	331	news, soft pedal on.....	777
Wisconsin State Fair abandoned.....	81	Shock absorber, Turner.....	377	Shows, gossip of coming.....	505
to educate public.....	827	Spanner-wrench, Denham's.....	377	St. Louis dealers announce show.....	830
		Spark plug, Messerschmid.....	977	hold early show.....	371
		plug, Mezger.....	929	Syracuse show to follow Boston's.....	1033
		Speed-change mechanism.....	789	Syracuse show, bird concert at.....	1121
		Spickernagle top fastener.....	1067	Toledo will have show.....	989
		Spring tire, Graham.....	377	Washington plans.....	965
		Starting device.....	421	Welding and cutting, oxy-acetylene.....	1143
		Starting valve, Alakson.....	977	Winnipeg's show is quickening trade.....	120
		Steering and driving mechanism, Siders.....	929	Worcester, winter show for.....	463
		gear.....	511		
		mechanism, Benton.....	649		
		Storage battery and treating process.....	421		
		Tail light and number plate, Cake.....	1025		
		Tender for Traction engines.....	789		
		Tire protector, Scott's.....	559		
		re-enforced by armor fabric.....	837		
		Torch, welding or cutting.....	467		
		Transmission, Morgan.....	977		
		Twist drill.....	511		
		Valve gauge.....	789		
		regulating.....	467		
		Teetor's.....	1025		
		Van Scotar safety crank.....	1155		
		Wheel, Myers.....	977		
		Worm drive and compensating gear, Ross'.....	331		
		Wheel, resilient.....	467		
		Winton valve mechanism.....	1111		
		Zisch carbureter.....	1067		

## MY BEST REPAIR

Accidents, a chapter of.....	635
Burnt-out bearing—got home.....	635
Candles for the headlights, real.....	1056
Clutch slips.....	682
Gasoline exhausted, what to do.....	960
Gauge, gasoline.....	960
Leather workers.....	728
Letcher pneumatic jack.....	1111
Lock, effective safety.....	1056
Manifold, cracked intake.....	682
Rope tire.....	728
Safety cranks, voices the need of.....	1056
Spring repair, broken valve.....	635
Steering column, repair of broken.....	774
Studs, broken.....	682
Terminal protection.....	1056
Tire pump.....	728
Tires—using old casings.....	912
Timing gear teeth.....	1008
Valve spring broken.....	729

## PATENTS GONE TO ISSUE

Acetylene generator, Rose.....	649
Adjustable brake, Lincoln's.....	559
Air compressor, Costello.....	741
Alltree gas engine.....	1067
Automobile sleigh, Finkelstein.....	929
Blow-torch, Weintz.....	741
Bourne windshield.....	1155
Brake connections, Davis.....	929
Carbide indicator.....	789
Carbureter.....	421
A. Weiland's.....	697
Mallo.....	977
with spreader members.....	837
Car truck.....	421
Clutch.....	511
Boyle's.....	1025
Brewin's.....	929
Robinson's.....	881
Thurston's.....	649
Utz's.....	977
with bearing and races.....	837
Collins tire signal.....	1067
Coffin explosion engine.....	1111
Combined muffler and air heater, Lewis'.....	559
Control mechanism.....	467
Controller, automatic.....	789
Controlling mechanism, Coffin.....	881
Cooling, means for engine.....	511
Demountable rim, Scott.....	977
Dennison friction clutch.....	1067
Diabl liquid atomizer.....	1111
Differential gearing.....	789
Drive, Miggitt.....	741
Drying mechanism.....	421
Mechanism, meter.....	1025
Electric lamp, Perry's adjustable.....	331
welding, Lachman.....	649
Engine, Internal Combustion, F. Oberhaensli	697
silencer, Smoot-Masterson.....	559
starter, E. A. Halbleih.....	697
Farquharson force-feed carbureter.....	1155
Fender, Conover.....	377
Forsythe engine.....	1111
Friction Device, Freer.....	929
Gas Turbine, Atwell.....	377
Gearset, compensating.....	511
Greenleaf speedometer.....	1067
Grinder for valves.....	421
Headlight adjuster, Cunningham.....	1025
Heater, Cullman.....	1025
Hydrocarbon power plant.....	789
Internal combustion engine, Swain's.....	331
Combustion motor, Belknap.....	881
Ionides backfire extinguisher.....	1155
Lamp, acetylene.....	837
combined signal and display, A. M.	
Puckett.....	697

## SHOWS, NATIONAL AND LOCAL

A. M. A. A. Show Committee, Bergdoll to	
head.....	78
Atlanta may promote a show.....	1033
Atlanta show will be February 10-17.....	1121
Aluminum castings, firm, clean.....	1144
Baltimore plans big exposition.....	923
exhibition planned for.....	831
Sliding space scale at.....	1122
Banquets, setting dates for.....	415
Berlin's international show.....	755
Berlin, impressions of American visitor at.....	828
Blackening copper, brass and other metals.....	1144
show, body styles at.....	828
Boston's two shows.....	436
Canadian national shows progressing.....	1033
Chicago show successful.....	685
show week.....	617
truck week prospects.....	965
the N. A. A. M. shows at.....	616
Cincinnati show in Music Hall.....	874
Cincinnati show in music hall.....	1033
Cleveland show sanctioned.....	923
Coming shows, gossip of the.....	463
Denver space exhausted.....	989
Detroit, additional space necessary at.....	1032
Detroit, new cars to make their bow at.....	1105
Detroit dealers show Jan. 22-27.....	965
sees first show.....	483
space all under contract.....	1121
to hold season's first show.....	321
Fluid pressure speed-changing.....	1132
Garden show, exhibitors' list at.....	1034
Garden spaces drawn.....	411
to house last show.....	195
Gossip of coming shows.....	549
Importers Salon will show 17 foreign cars.....	1032
Importers draw space.....	989
Indianapolis fall show.....	923
to hold fall show.....	831
Kansas City, one show in.....	830
Madison Square truck show to have 231 ex-	
hibitors.....	923
Midsummer show at Des Moines.....	285
Milwaukee show, motor exhibits at.....	436
show date advanced.....	830
show in auditorium.....	874
M. & A. M. allots show spaces.....	636
M. & A. M. show week meetings.....	1033
National and local show news.....	1104
National will show in Breslin lobby.....	1105
News of other local shows.....	1105
N. A. A. M. and M. & A. M. to show at	
palace.....	78

## TECHNICAL

Accidents come in groups.....	346
Acetylene and its uses.....	904
Albion motor fitted with two piston valves.....	304
Aluminum alloy for pistons.....	1003
expert reports on.....	484
Angularity in steering wheel's setting.....	298
Battery terminals, care of.....	215
Blood motor, rotary disc valve of.....	388
Boiling of liquids, theory of.....	34
Breakdowns, preventable.....	673
Broc motor utilizes a double piston.....	179
Calibration of parts is vital.....	142
Carbon deposits in cylinders.....	35
Carburetor cock, proper form of.....	12
Carbureters with sunken jets.....	270
Carroll & Ripley use a single sleeve.....	51
Case hardening, its equipment.....	970
Chain, as to the silent.....	107
Chalmers takes kindly to the two sleeve.....	49
Charging storage batteries by dynamo.....	33
storage batteries from alternating current.....	33
storage batteries from a main.....	32
Chassis frames, Franklin wooden.....	154
Clegg uses elliptical ring.....	389
Clifton motor utilizes rotary valve.....	302
Clutch troubles, to remedy.....	224
Coal, a new fuel, pulverized.....	620
Combustion, dilution arrests.....	193
heat due to.....	537
Compression noticeable at low speeds, poor.....	225
Cooling and efficiency.....	186
troubles, their symptoms.....	400
water from freezing, keeping.....	1100
Cottareau motor, split rotating ring in.....	179
Cotton waste, careless use of.....	251
Daimler-Mercedes makers patent overhead	
rotary valve.....	222
De Dion rotary sleeve motor.....	221
Design influenced by long-stroke.....	812
Differential, purpose of the.....	313
Driving-shaft oscillations, destructive.....	1088
D'Orsay McCall White type of motor.....	49
Empress motor has water-cooled rotary valve.....	221
Energy diagrams and efficiency.....	147
loss of from motor to wheels.....	147
where wasted goes.....	147
Exhaust of motor, how to analyze.....	762
Facilities for the hardening room.....	100
Fan-design, suggestion for.....	272
Fans, inaccessibility of.....	143
Finishing, automobile.....	141
Flame welding and cutting.....	1093
Fluid pressure speed changing.....	1132
Gears, measuring efficiency of.....	1093
Gear-probing methods, new.....	1092
Gearing, variable speed.....	511
Gas generator needs care.....	349
Gasoline-electric passenger service.....	184
motors, rating of.....	344
Gaubert sleeve motor, principles governing,	
operation of.....	303
German invention similar to Knight's.....	221
Glycerine treatment of steel.....	1011
Gravity feed of tanks.....	313
Griffith uses a rotary valve.....	221
Hardening room, facilities for the.....	100
Hay motor employs two rotary valve sleeves.....	303
Heat losses of cooling.....	264
Hiscock uses two concentric pivots on valves.....	224
Hooper motor employs stationary and rotary	
sleeves.....	303

# THE AUTOMOBILE

Howard motor, showing construction of.....	48	analyzed .....	299	stem lubrication, useless to bring over..	257
Hupp enters gasoline field.....	416	Permanent developer .....	1093	type, small motor is of.....	221
Interest, short stories of current.....	97	Pistons seize, warning in advance.....	132	Valves claim attention, rotary sleeve.....	179
Kerosene for automobiles.....	133	Production and science, mass.....	1051	looking for something new in.....	220
King motor with single external rotary sleeve	181	Poppet valves, in the making of.....	528	W. J. Crossley uses two rotary sleeves..	179
Kitchen, J. G. A., contributes quota of	51	Power, distribution in car.....	148	Valveless ideas, a plethora of.....	387
sleeves .....	51	engine appears to lose.....	231	motor, a new type of.....	232
Knight, Charles Y., explains his engine.....	548	of motor, loss of.....	265	motor research.....	302
makes modification of main type.....	48	Propellers aerial, differential for.....	74	Vanadium, as to the merits of.....	145
motor, Columbia out with.....	13	Radiators, soft water for.....	263	as to merits of.....	357
motor, early history of.....	3	Redrup type of sleeve motor, referring to...	48	in steel.....	99
Lamin motor, piston and sleeve valve used in	304	Renault rotary sleeve valves show originality	305	Varnishes, patent truths concerning.....	141
Lancaster motor of the two-sleeve type.....	50	guiding thoughts as voiced by.....	1050	Von Laucerer uses a rotary sleeve.....	221
Live axle makeshift repair.....	181	Reno Bois, place sleeves in cylinder head...	47	Ward motor has sliding block.....	387
rear axles, some problems of.....	259	Reo the Fifth—Olds' latest model.....	1084	Water in cylinders causes trouble.....	305
Long-stroke motor for cars.....	811, 994	Repairs, practical automobile.....	142	Welding and cutting oxy acetylene.....	1143
Lubricating problems, in further relation to..	54	Revolutions per minute, standardized.....	811	Wheel lock, accurate registering of.....	301
Lubrication, Amplex system of.....	30	Richards employs reciprocating piston.....	180	White Company adds six to line.....	56
Bergdoll system of.....	110	Riley imparts motion to the sleeves in in-	50	Wobbling wheel; why it occurs.....	299
Colby system of.....	30	genious way.....	50	Wolseley employs sliding piston valves....	224
Correja system of.....	110	Rolland & Pillain, single sleeve motor.....	47	Zeitlen motor has overhead pistons.....	223
Cunningham uses splash.....	70	Rotary valve, Martin uses.....	387	Zinc and copper alloys with aluminum, merits	33
Daimler adjustable troughs.....	153	Rowell motor, two rotary disk valves used in	304	of .....	
E. M. F. system of.....	110	R. P. main piston speed, relation between	225		
Fiat system of.....	31	Ruhher, synthetic.....	60		
Ford system of.....	111	Rustproofing methods, modern.....	761		
Haynes scheme in detail.....	70	Rutenber motor, the model X.....	244		
Hupmobile system of.....	70	Sears, I. E., operates a pair of sleeves.....	52		
Kissel-Kar system of.....	30	Serex motor has two sleeves.....	224		
Knox system of.....	110	Sight feeds, smoke in the.....	231		
Marion combination system.....	152	Silence, the search for.....	101		
Maxwell uses splash.....	71	Silent motor, coming of the.....	66		
Mercur system of.....	71	Silicon, effect of on steel.....	66		
Moon system of.....	31	Single sleeve motor, Rolland & Pillain.....	47		
National system of.....	110	Six-cylinder Knight introduced in America..	285		
Ohio system of.....	111	Skidding, some facts as to.....	193		
on hills.....	225	Sleeve motors, a deluge of.....	86		
Packard system of.....	31	types of motors, American.....	4		
Paige-Detroit.....	152	Sleeves in cylinder head, Reno Bois place..	47		
Panhard & Levassor is automatic.....	152	Solid tires, S. A. E. adopts standard.....	321		
Pope-Hartford system of.....	70	Spark plugs, huy suitable.....	252		
Pullman system of.....	71	Spring, front, deflection, effect of on steering	301		
Renault system of.....	31	gear.....	139		
Royal tourist, circulating.....	153	shackles, care of.....	639		
Stevens-Duryea mechanical oiler.....	153	Standards extended, truck wheel.....	178		
Stoddard-Dayton system of.....	30	Starting crank handle cuts bard at times...	99		
S. G. V. system of.....	111	Steel, vanadium in.....	149		
Thomas circulating scheme.....	152	Steering gears, how assembled.....	297		
Winton system of.....	71	mechanism, problems of.....	32		
Mercedes patenting valveless motors.....	224	Storage battery charging equipment.....	97		
Metallurgy of automobile made easy.....	403	Stories of current interest, short.....	103		
896, 962, 1010, 1058, 1090, 1136		Suspensions, how to improve barsh.....	179		
Maxwell, ramifications of the.....	50	Swift motor employs horizontal rotary sleeve	205		
McIntosh type of motor has overhead mechan-	387	Taper fits and limits of tolerance.....	950		
ism .....	303	Tesla's new mechanical principle.....	112		
McLeod combination of rotary and poppet...	49	Testing equipment discussed, Wheeler &	101		
Minerva motor built under Knight license...	75	Schebler.....	187		
Moore, W. W., resorts to single sleeve.....	86	shop, labor-saving device in the.....	273		
Motion study, as to.....	61	Thermal efficiency, changes in.....	417		
Motors, a deluge of sleeve.....	139	Tire damage by car tracks.....	537		
coming of the silent.....	174	pointers for the motorist.....	402		
inventors quest for silence of.....	49	pressure, correct.....	532		
noises, and cure of.....	531	Tires and rims.....	1046		
"soft" or "nervous".....	1050	stresses and strains in.....	1046		
Motor and pump, direct-connected.....	622	Torque, transmission ratio and.....	444		
Mustard comes out with modification.....	387	Transmission ratio and torque.....	231		
Nitrogen, steel should be tested for.....	50	Upkeep of the car, the.....	180		
Non-ferrous metal exposition in London.....	1143	Valve caps, removing tight.....	257		
Oil-burning motors, commercial.....	1059	Corliss rotary type.....	220		
Oscillating valve of French design.....		head, altering.....	220		
Overhead mechanism, McIntosh type has.....		motor, Lewis slide.....	221		
Oxy-acetylene welding and cutting.....		motor, Marshall rotary disc.....			
Oxy-gasoline flame.....					
Parallel vs. angular setting of steering wheels					

## TOURING

Alhion and Vaterland tour together.....	118
Antipodean automobiling.....	66
Australia, long-distance touring in.....	102
Blue Book fleet to rival "stunt" cars.....	37
Canadian Rockies crossed by Calgary club...	618
Capital highway, South's trunkline.....	850
Continent and back, across the.....	1069
E-M-F and Flanders owners to tour.....	373
Foreign lands, items from.....	135
tour, Schaeffers to make.....	79
Garden of Allah as touring field.....	1113
Garford tour on Santa Fe trail.....	734
Geneva to the Riviera.....	132
Georgia, around, tour.....	749
Good prize for Dawson run.....	1018
Hoosiers plan Southern tour.....	919
Jersey, how to avoid on tour South.....	341
Lebanon road temporarily closed.....	281
Luther Temple Club to run.....	365
Maps, T. C. A., convenient for tourists.....	78
Minnesota-Helena tour.....	162
Modern Acadia, motoring in.....	52
New England hills free from heat.....	251
tourists, timely hint for.....	121
North Carolina.....	942
Premier caravan on westward way.....	43
caravan at San Francisco.....	235
caravan finishes tour.....	280
transcontinentalists progress.....	78
tourists pass through Omaha.....	119
Pullman owners tour to factory.....	875
Richmond "hy automobile," on to.....	211
road enthusiasts will tour to.....	641
Salerno to Sorrento.....	133
Shenandoah Valley to Hot Springs.....	486
Sicilian tour, word-picture of a.....	91
Southland calls to the tourist.....	619
South Carolina, a jaunt through.....	1038
Springs to hard coal mines, from.....	440
T. C. A. tour's progress.....	749
Virginia touring.....	802
Water Gap is delightful, tour to.....	171
Wisconsin tour, twenty-six contestants in...	119
Word-picture of a Sicilian tour.....	96

# THE CLASS JOURNAL COMPANY

231-241 WEST 39<sup>TH</sup> STREET

NEW YORK CITY

# THE AUTOMOBILE

## Coming of the Silent Motor

### What the Market Affords Besides the Poppet Valve

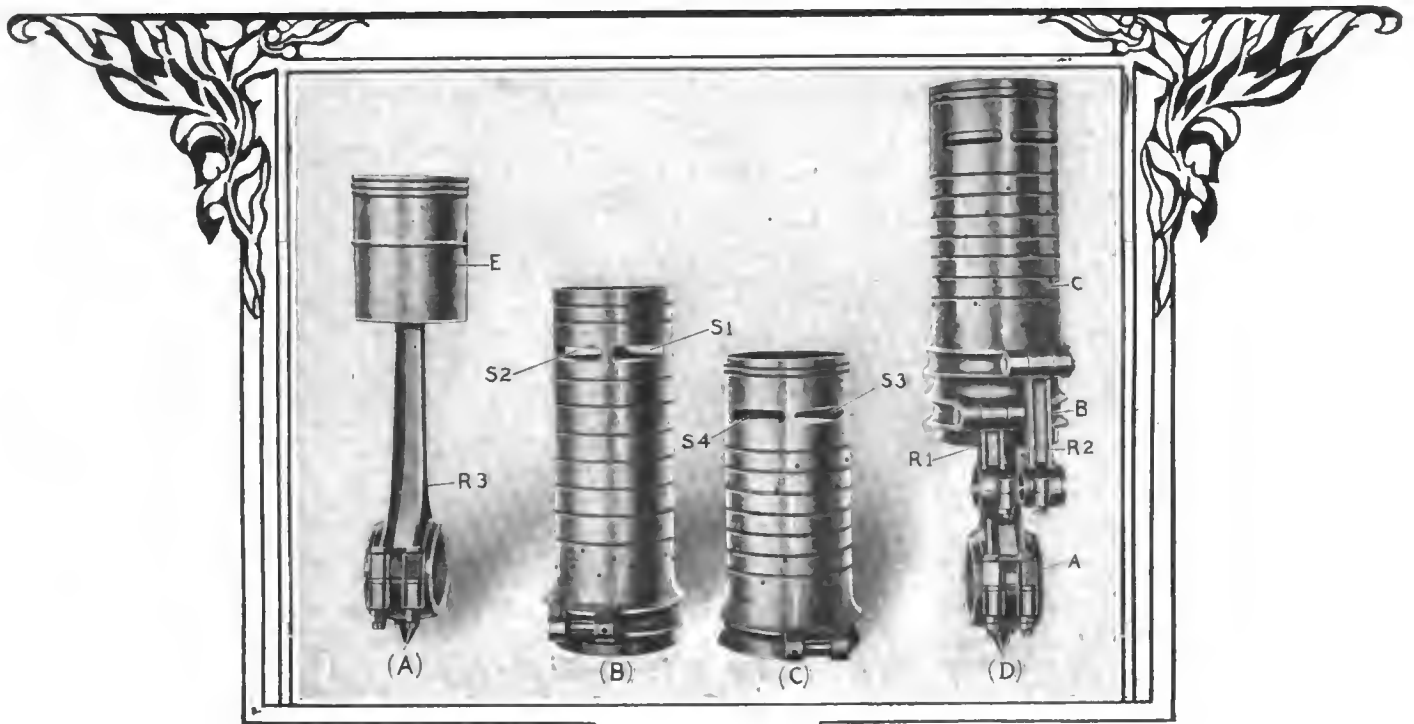

Fig. 1—Presenting the connecting rod assembly of the sleeve type of motor, also the connecting rod with its piston in place, as well as the sleeves after they were taken out of a motor following 6,000 miles of tryout work

*Thomas J. Fay, Editor of THE AUTOMOBILE, presents the first of a series of articles dealing with the problems of motors, with particular reference to other than poppet valve types, taking up the several questions as they are influenced by the conditions of the service in America, relating the causes for the differences in the practices between American and foreign countries, taking advantage of the actual products as they are being made in America to illustrate the points to be emphasized.*

**A**UTOMOBILISTS in this country have listened to the murmurings of the builders of automobiles in England and on the Continent, and the trend in these quarters has undoubtedly been in the direction of the sleeve type of motor and the silent chain. Coupled with these stars of the automobile world the long stroke design of motor has been a conspicuous factor, but few indeed are the students of automobile designing in this country who were able to account for the lethargy of American designers, if such it was. At all events, the production in this country has been held tenaciously to previously

fixed standards, and a careful study of the situation would seem to indicate that the acumen of the American maker has not been dulled by practice in the face of a divergency of experience.

That a fact may be quite apparent to even a man of skill, and yet be difficult to define, is shown by the very delay that is present in the motor situation; and those who have given themselves to the task of understanding these things long ago arrived at the conclusion that a good automobile on a Roman road in France or in England is the veriest junk pile on a dirt road in America. We cannot run cars in this country when the clearance is four inches, nor can we accept the practice of the builder of the type of car that has a four-inch clearance, hampering the same by the mere expedient of changing the camber of the springs to get the extra clearance when it is desired to ship and use this foreign clearance car in places where the roads are substantially unimproved.

If an automobile is to perform with good satisfaction on unimproved roads it must be designed with special reference to the road condition, and the clearance that must obtain requires a considerable effort on the part of the designer, since he must depart absolutely from foreign practice, and, while holding the



center of gravity as low as possible, keep the mass from scattering, and poise the same so that it will not partake of a cranky set of movements in response to speed and road inequalities. It would have been a simple matter for American designers to accept the practice as it comes from overseas and enjoy the good performance of the sleeve types of motors, were there nothing in the rest of the designing problem; but wisdom and experience have had the effect of applying the brake to activities of this character for a sufficient time to permit the designers to revise the chassis characteristics to accord with the new requirement.

It will be impossible to predict the extent to which sleeve and rotary types of valves will be used in automobile motors in the near course of events, but there is ample evidence of the fact that this movement is wide and appearances are in favor of the contention that it has taken on a permanent phase. At all events, the time has arrived when it will be opportune to present the whole subject in a series of articles, rather than to try to cover the matter in a single article at some length, but it is not believed that there should be much more theorizing, nor is it necessary to thus lamely proceed, since examples of the work that is being done may be used to illustrate the points to be made, and for this particular effect the new Stearns-Knight and Columbia-Knight motors will be described and discussed.

**Discussion Is Toning Down in the Light of Experiences Gained**

Some years ago when Charles Y. Knight brought out his sleeve type of motor in America he was evidently ahead of the state of the art, and he was unable to arouse any considerable measure of interest in this type of motor at that time. Circumstances culminated in the bringing out of the Silent Knight motor in England, and the success of this motor under the direction of the British-Daimler Company was sufficiently marked to attract the attention of such companies as the Panhard in France, Minerva in Belgium, Mercedes in Germany, and the company of the same name in Austria. The earlier negotiations on the part of Mr. Knight with the makers of automobiles in America made it somewhat uncertain as to which of the companies would adopt this motor, and we understand that the Knight contract with the above named foreign makers

of automobiles is such that his right to license American companies is limited to four concerns. We are unable at this time to enter into a description of the Knight type of motor as it will be used in more than two of these companies, and the descriptive matter hereinafter is confined to the Stearns-Knight motor and the Columbia-Knight motor, and we regret to state that the information given in relation to the Columbia-Knight motor is somewhat less complete than is our wont, due to the fact that the Columbia-Knight car is going through long and continued road tests, so that it has been impossible to get photographs of such of the details as would seem to lend interest to this discussion, so that right is reserved to go into the matter of details at some length at a propitious time.

There will undoubtedly be a great deal of discussion in relation to the sleeve type of motor versus poppet valve types of motors, and users of automobiles may have some difficulty in arriving at a proper conclusion of the position that they ought to take relative to these types of motors. But users of automobiles can well afford to take into account a plurality of considerations; for instance, in the preparation of material that will be used in the further discussion of motors in articles that we propose to run, discovery has been made of 54 designs of motors, other than poppet valve types, that have been worked upon and are being tried out with more or less satisfaction. It is not the purpose here to either suggest or advocate that comparisons be made in the absence of authenticated data, and we are struck by the fairness of the attitude of Charles Y. Knight in his discussion at various times relating to the merit of the sleeve type of motor as it compares with motors of other generic types. Quoting from Mr. Knight's paper entitled "The Valveless Engine" in a paper read before the Royal Automobile Club as far back as October 15, 1908, Mr. Knight said: "It was not valve trouble which inspired me with the desire to build a motor different from the then accepted type." From this statement it will be seen that the inventor had no grievance against poppet valve types of motors of the character that is brought to bear in promiscuous discussion, and we will have to look further in Mr. Knight's presentation of his matter to find out what he did think. In this connection the inventor went on to say, "I struck out boldly along new lines

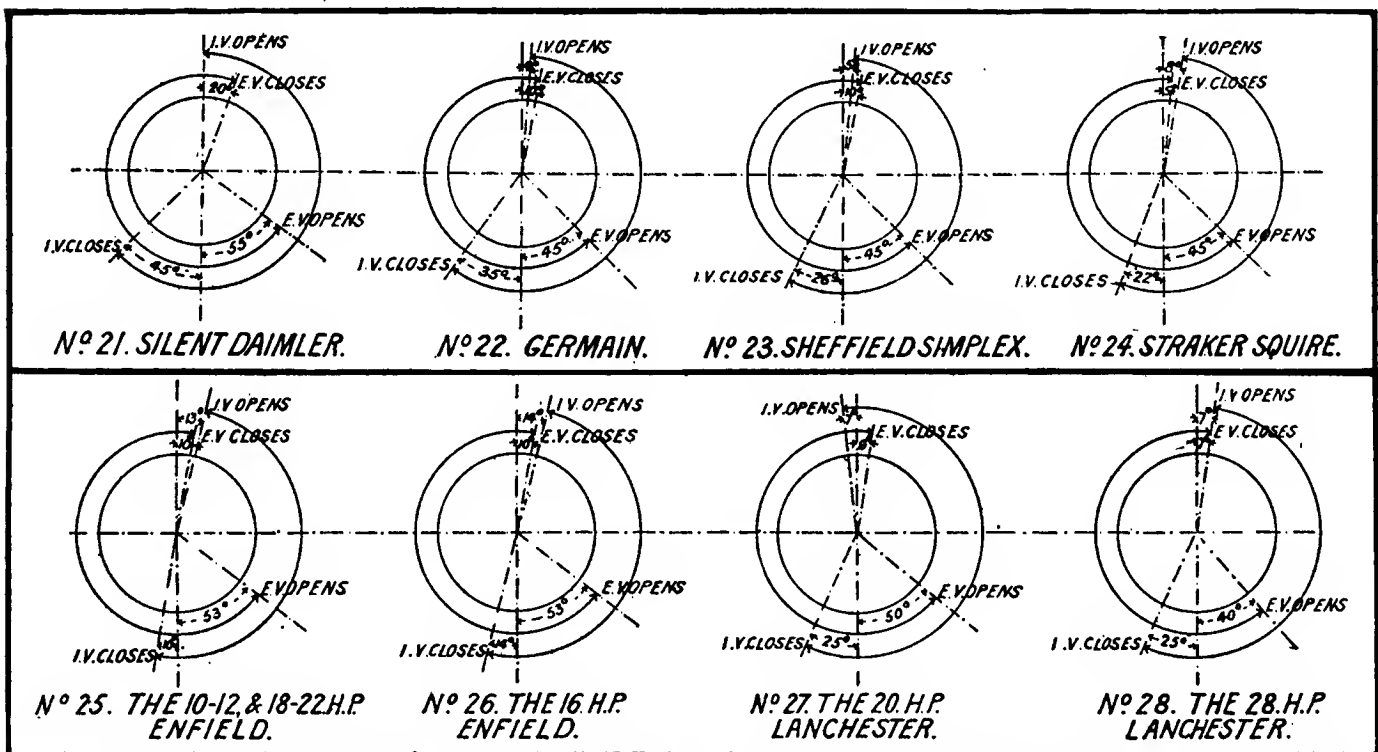

Selection from a series of timing diagrams that appeared in the Motor Car Journal, showing the settings of the intake and exhaust valves of several different makes of motors, including a Knight motor

for the very good reason that close association of over 20 years with mechanical matters taught me that a novice in any special field had little chance of improving upon an accepted design. I clearly made up my mind, if possible, to produce an internal combustion motor different from anything which had yet been constructed." It will be seen from this statement that Mr. Knight's initial interest in the matter had the same impetus as that which induced hundreds of inventors in many lands to build automobile motors, and, like his confreres in the same zone of activities, he had to take his chances with the rest and follow the bent of an inventor's inspiration, buoyed up by the enthusiasm of which genius always has a surfeit.

In putting the matter up to the British-Daimler Company, Mr. Knight relates the attending circumstances in language as follows: "We did not bring to the Daimler Company an untried proposition. We brought a practical although not refined product—a motor which had already withstood the test of public use for two years, and came through with clear records, numerous drastic tests in public competitions with the best motors of the other types." In pronouncing on the question of power, Mr. Knight states: "The only feature regarding which we made no representations to the Daimler management was the matter of power as compared with the other types, as conditions under which tests are made in different establishments vary to such a degree that even now I place little credence upon what I read regarding the performance of any motor under tests in its own works."

#### Early History of the Knight Motor Building Effort

In recounting his adventures Mr. Knight stated in his paper of October 15, 1908: "Experimental work began upon this motor five years ago last August. The first model was 3 1-2 by 4 inches, single cylinder horizontal. It was operated successfully through the use of but one sleeve, but the gear necessary to give it the proper motion was too complicated to be quiet, and this construction later gave way to two sleeves driven from an eccentric shaft. We experimented one whole Winter in the shop before any effort was made to design a practical motor for car use, and when this motor was finally undertaken during the winter of 1904, the result was a four-cylinder engine, 3 1-2 inches bore by 4 inches stroke. This motor was finished in October of 1904 and put into a Panhard type car which I had driven for two years. This motor is running to-day in the self-same car. I

drove it about 4,000 miles that winter and about 8,000 miles the next season.

"We designed and constructed our first experimental car in the Spring of 1905, this being equipped with a four-cylinder 4-inch by 4 3-4-inch motor, with practically no change in design. This car is in service to-day."

A side light upon the activities of the inventor in this case will suffice to indicate something of the vicissitudes that beset the path of the soldier of fortune and the man who wants to bring out something new, and Mr. Knight's own language will best bring out the point that is here to be made: "I have no doubt that had I come into contact at that time with some of the critical experts whom it has been my good fortune since to meet I should have been dissuaded from spending a dollar upon the idea, yet, in the light of recent startling mechanical and scientific developments, I have almost reached a state of mind when I hesitate to entertain or express doubts regarding the possibilities of any reported accomplishment. \* \* \* Frank Munsey, one of the world's most successful publishers, in a treatise on the subject of 'Schemes' for increasing the volume of business, said: 'If you have an idea and have confidence in yourself go ahead and work it out. It's all well and good to look around and see just what is the condition of the channel ahead of you, but if you have any hope of being successful don't by any means call in a dozen advisers and discuss your scheme with them. The best idea that was ever born can be talked to death around a council table. If you expect to devise anything that does not involve some risk you are smarter than the average smart man. If you have an idea and have confidence in yourself it is up to you to grasp the situation vigorously and surmount the obstacles. Counsellors will undoubtedly point out stumbling blocks. It is for you to get over these. Any man can do an easy thing. Ability means the power to do things other people think cannot be done or fear to undertake.'" In thus taking serious notice of the rather good advice from the trenchant pen of Frank Munsey and emulating the idea in practice under what must have been a difficult set of conditions, Mr. Knight has been good enough to indicate one of the reasons why he reached the goal of success, and this may be the precise ground that other inventors take in the struggle that is now going on, nor can we tell at this time how many individual efforts are being given the force of persistent attention, excepting that we have been able to find 54 examples outside of the poppet-valve field.

## Stearns-Knight Motor Introduced

### Chassis Revised to Assume New Responsibility

*A discussion of the new Stearns-Knight motor, presenting reproductions of working drawings of the chassis, and halftone reproductions from photographs of the motor after it was operated in a car for about 6,000 miles and taken apart under the direction of the author for the purpose of observing the conditions for lubrication, showing the condition of bearing surfaces of the sleeves and other functioning parts of the motor. From the power point of view a Prony brake test is given of the new Stearns-Knight motor, and a second Prony brake test is offered showing the power and characteristic of the Stearns poppet valve type of motor, the idea being to bring out the difference in the service characteristics of the two types of motors and to show wherein the Stearns-Knight motor differs from the earlier effort.*

REMEMBERING that there will be ample opportunity on the part of the patrons of the automobile industry to gather such information as may be had in the course of mere discussion bearing upon the features of sleeve types of motors, it seemed to be in keeping with the situation to examine into the performance of the new Stearns-Knight motor as it is made in the plant of the F. B. Stearns Company, Cleveland, Ohio, and to compare the details of actual road performance with the motor characteristic, observing in the meantime the extent of agreement. In the road tests it was found that the motor throttled down under hill-climbing conditions and accelerated on a grade satisfactorily even with a fixed spark advance, and that the motor presents a wide range of stability despite an indifferent attempt at timing the spark. It will be remembered that the timing of the Knight motor is a matter that the designer is permitted to fix upon much in the same way that poppet valve types of motors are timed, and the dia-

gram given below shows the preferred timing as fixed upon by Charles Y. Knight in his effort on behalf of the British-Daimler Company compared with accepted timings of good makes of poppet valve types of motors, and it will be seen that the Knight timing is as follows: The inlet port is timed to open on the top dead center and to close 45 degrees up on the compression stroke. The exhaust port opens (early) 55 degrees before the end of the firing stroke, and closes (late) 20 degrees down on the suction stroke.

Referring to the curves of motor performances as shown in Fig. M of the Stearns-Knight motor as compared with Fig. N of the Stearns poppet valve type of motor, it will be at once apparent that the torque characteristic of the Knight type of motor is at wide variance with the torque characteristic of the Stearns poppet valve type of motor. A mere examination of the torque curve of the Stearns-Knight motor would suffice to show that it is an easy motor to crank, and actual experience with the motor bears out this surmise. In the face of "soft" cranking, which would indicate poor compression in a poppet valve type of motor, the actual torque at low speed is relatively high, and it is an advantageous fact that this torque increases with increasing speed for a large part of the range, and recedes but slowly thereafter up to 2300 revolutions per minute.

#### What Investigation Shows in Relation to the Performance of American-made Sleeve Types of Motors

Referring to the illustration (Fig. 1) of the Stearns-Knight motor construction, (A) shows the piston and connecting rod, (B) is of the inner sleeve, (C) presents the outer sleeve and (D) is an assembly of the connecting rod A with the inner sleeve B and the outer sleeve C in the concentric relation with the piston E just as they go in a cylinder of the motor. These sleeves are reciprocated by means of connecting rods R1 for the inner sleeve and R2 for the outer sleeve, and they are actuated by an eccentric shaft S1 in Fig. 7, whereas the piston attached to its connecting rod R3 is actuated by the crankshaft C1 in Fig. 7. The group as shown in Fig. 1 supplemented by the crankshaft and eccentric shaft as presented in Fig. 7, constitute the functioning mechanisms in the Stearns-Knight type of motor in substitution of poppet valve mechanisms of former practice. Instead of actuating poppet valves for the purpose of controlling the mixture and the exhaust, the sleeves B and C in the concentric relation with the reciprocating piston move on each other so that the slots S1 and S2 in the sleeve B register with the slots S3 and S4 in the sleeve C in registry with transfer ports in the cylinder proper, according to the most approved four-cycle timing of a motor, thus doing the work as it is required in the performance of the motor according to the Otto cycle.

By referring to Fig. 6 it will be seen how the sleeves (B) and (C) fit in the bores of the cylinder (A), and the transfer ports P1 and P2 as they show in this pair of cylinders are so placed as to register with the slots S1 and S2 of the concentrically related sleeves (B) and (C) when they are nested in the cylinder, of which there are four in this motor, for the intended purpose.

#### The Piston Is Flattened on Two Diameters in the Plane of Minimum Pressure for the Purpose of Working the Motor with Low Clearance.

Fig. 2 shows a pair of the cylinders as they were photographed in place on the motor as it was taken down by the writer after the automobile in which it was mounted had traveled approximately 6,000 miles, and in view of the fact that the photographs were taken by a most excellent camera under particularly favorable conditions, the reader is enabled to judge of the conditions of lubrication that must have obtained during the entire performance of the motor, as indicated by the highly polished surfaces at every point, with entire absence of scoring or other blemishes such as would be present were the lubrication faulty and the motor made to serve for so long a time in a "try-out." Referring to Fig. 2 in the cylinder S1, the surfaces that come

into view are of the cylinder wall proper, whereas the surface S2 is that of the offset of the cylinder, and the surface S3 is the inner surface of the short sleeve as shown in (C) in Fig. 1, bringing the edge of the long sleeve S4 into view. The holding bolts B1, B2, B3, B4, B5, and B6, for each cylinder, are used to hold the cylinder heads as they are shown in Fig. 5 in place; and referring to this latter figure the junk rings R1, R2, R3 and R4 are clearly indicated above auxiliary rings R5, R6, R7 and R8. The junk rings and the auxiliary rings above them bear against the inner surfaces of the long sleeves maintaining tightness between the junk ring assembled in the head of the motor and the bore in which the piston reciprocates, thus preventing compression from leaking around the tops of the rings or through the openings in the sleeve, it being the case that the junk ring is so wide that it covers the sleeve ports, including a considerable overlap for the obvious purpose. The illustrations of the four cylinder heads H1, H2, H3 and H4 in Fig. 5 having been reproduced from photographs of the actual cylinder heads as they were taken out of the motor by the author, show the effect of the long service test to which the motor was subjected, and the junk rings clearly indicate that the surfaces all over were highly polished and that the conditions of lubrication were particularly good. The cylinder heads have cavities C1, C2, C3 and C4 forming the combustion chamber proper, and the spark plugs S1 shown in the head H3 protrude through the depressed heads into the hottest part of the combustion chamber, where they are in the flush position, and the thermic conditions obtaining are somewhat indicated from the fact that the growth of a carbon deposit is only barely indicated at G1 in the head H1, at G2 in the head H2, and G3 in the head H4, it being the case that the head H3 is tilted so that the cavity does not come into view, but the author is able to state that the coat of carbon residing therein was in no greater presence than that shown in the examples that are here to be seen.

The two cylinders as presented in Fig. 2 were the third and fourth of the motor lying next to the dashboard in the car. The two front cylinders were removed and were photographed, as shown in Fig. 6, alongside of one of the pairs of sleeves. Referring to Fig. 10, the front end of the motor with the front pair of cylinders removed is brought into view, and the sleeves of cylinder No. 1 were then removed, allowing the piston P1 to be seen, showing the piston rings R1, R2 and R3 above the piston pin, and the piston ring R4 in the plane of the piston pin, all of them in a highly polished state, showing every evidence of good lubrication and a tight performance. The piston head H1 shows a slight growth of carbon G1 in the bowl, and attention is called to the fact that the piston head is depressed, forming a segment of a sphere, the idea being to properly regulate the compression ratio, remembering that the head is inverted and fills some of the space in the bore; but there is a further object in depressing the piston head, the portent of which is enough to dictate this shaping, it being the case that a layer of gas fills the depression so formed and shields the metal of the piston head from the hot glare of the burning gas, thus eliminating a very serious thermic trouble in motor work.

The second cylinder as shown in Fig. 10 was photographed with the sleeves S1 and S2 in place, and attention is called to the bright surfaces S3 and S4 around the port P2, thus indicating that a tight relation obtains, and it may be proper to say here that the presence of carbon at the lips of the ports has proven to be a boon rather than a detriment, due to the fact that the carbon and the lubricating oil are mixed and ground into an infinitely fine state, and the latter fills in the interstices, if such there are, leveling off the surfaces, perpetuating the condition of good performance, and this is probably one of the reasons why the Knight type of motor performs so very much better after a considerable period of service than it does when it is brand-new. In the investigation of the carbon deposit question for the purpose of finding out whether or not the sleeve type of motor would be clogged up by carbon deposits, a series of little grooves cut with a diamond-pointed tool were made on each side of one

of the ports of a sleeve, and the examination of this roughened zone in the proximity of the lips of the ports after a considerable service showed that the grooves had completely filled up with a prime carbon paste, and that the leakage which might have been induced originally by the roughening of the surfaces in this critical zone had departed entirely, and the motor performed quite as satisfactorily as if the sleeves had been left in their original polished condition. From this and other evidence it would seem that the original claims for the Knight type of motor, which had for their foundation the idea that the motor improved with service, are based upon the beneficial action that takes place when fine carbon dust is mixed with lubricating oil and rubbed into the surfaces of the metal. There is a great difference between forming a scale out of carbon, silicon and other substances and allowing it to deposit over the heated surfaces of the combustion chamber and the manufacture of a carbon paste, rubbing it into the pores of the metal as fast as it is formed, which is the action that takes place in the sleeve type of motor. In a word, the formation of carbon is beneficial to the motor, in that it manufactures graphite, which is known to be an efficacious lubricant, and as fast as this lubricant is manufactured it is taken up between the rubbing surfaces of the sleeves, and while it is being ground into an intimate mixture it is being rubbed into the pores of the metal, filling the interstices at every point and producing surfaces that are mirror-like in every particular.

#### Having Examined the Surfaces of the Sleeves from Photographs Taken from a Motor That Had Done Long Service It Remains to Study the Working Drawings and Observe of the Things That Were Done to Harmonize this Type of Motor in a Chassis That Has Proven Its Worth Under American Road Conditions

Referring to illustration C, which is a section of the motor through a cylinder, it will be seen how the long sleeve S1 serves as the bore for the piston P1, and how the short sleeve S2 is sandwiched between the long sleeve S1 and the cylinder wall W1. It will also be seen how the cylinder head H1 is flanged over at F1, fitting the cylinder proper, making room for the sleeves S1 and S2 between the bore of the cylinder in the head and the inserted part of the cylinder head H1, allowing also the space for the junk ring J1, which serves to cover the ports P2 in the outer sleeve and P3 in the inner sleeve, and with the sleeves in the position as shown the exhaust ports P4 in the outer sleeve and P5 in the inner sleeve are also covered by the overlapping of the sleeves under the conditions as observed, so that the combustion chamber is tight against compression, and any leakage possible to consider must pass by the junk ring J1, bleed across the lip surfaces and then negotiate the bearing faces between the sleeves. A study of the section of the motor in the vicinity of the ports will suffice to show that tightness against the leakage of compression is a condition that improves with service, due to the fact that the surfaces are slowly but surely undergoing a process of polishing. Moreover, the lubricating oil as it is sucked up between the sleeves has such a large surface to cling to, remembering that it has a high surface tension, produces a self-packing condition that is not to be overcome by any pressure that can be brought to bear, and the action that takes place under working conditions brings about the shearing of the lubricant in its section, so that the actual work done is within the molecular structure of the lubricating oil. It is impossible to consider that there is any metal-to-metal contact of the sleeves and the cylinder walls, and the polishing effect that is indicated by continued service is at such a slow rate that over 5,000 miles of travel of an automobile on the road under the impetus of this motor is barely sufficient to remove the evidences of grinding of the sleeves, in the face of the fact that the grinding work was done with scrupulous care.

#### Great Care Is Taken to Cool All of the Flame-Swept Surfaces by Carefully Directing the Flow of the Cooling Water

Referring again to Fig. C, it will be seen how the cylinders and heads are water-jacketed, and the baffle plates (not shown) direct the flow of the cooling water in a spiral sheet, sweeping over all of the surfaces, allowing the same to leave at the highest point, entering the water outlet at the top, traversing the length of the water manifold to the receiving point in the radiator. The extremely high mean effective pressure that is shown in this motor is partly accounted for by the liberal area of the inlet and exhaust ports, but a study of the motor performance goes to show that this accounting is insufficient, since the motor characteristic is markedly different from that which obtains in motors that have poppet valves of large areas with a timing the same as that which is employed in this particular motor. It has been suggested that the high mean pressure realized is in a large measure due to cold lips of the parts brought about by the precision with which a liberal supply of cooling water is permitted to brush the surfaces in juxtaposition to the lips of the ports, thus maintaining a constant low temperature. In the shaping of the inlet passageway, as it approaches the ports, it will be seen how the grade is sloping in the direction of the combustion chamber with entire freedom from "baffles," and it is pointed out that in this detail the Stearns-Knight type of motor differs materially from the earlier Knight designs, it having been found that this sloping of the gradient prevents the accumulation of liquid fuel and adds materially to the smoothness of performance of the motor, but it is to be regretted that this section illustration does not show that the hydraulic grade is in the direction of the carbureter rather than in the direction of the combustion chamber of the motor for the major portion of the distance, the divide coming in the transfer port as it approaches the combustion chamber of the motor. An examination of the exhaust port, as compared with the inlet port, shows a distinct difference in detail. For instead of a smooth approach, as required on the inlet side, the lip curls up and the exhaust gas after it passes out is permitted to expand, and it would seem from what has been observed that the compact screen of gas remains in its compact state until it gets by the port, after which it swells, maintaining a certain intimacy, and it departs by way of the exhaust manifold as a body, thus leaving behind a certain excellence of the state of scavenging that has not been experienced heretofore.

In the design and construction of the sleeves S1 and S2 as shown in Fig. C care has been taken to thicken the walls at W2 for the long sleeve and W3 for the short sleeve for the purpose of adequately resisting the work that they have to do in the interpretation of the reciprocating motion as it is delivered to the sleeve by the connecting rods R1 for the long sleeve and R2 for the short sleeve, as delivered through the good office of the eccentric shaft E1. The bosses to which the connecting rod pins relate are joined to the sleeve through the section of metal formed with a pair of parallel ribs running around the girth at the extremities of the sleeves. The fact that the sleeves are given their reciprocating motion by means of connecting rods, actuated by an eccentric, imparting the motion to one diameter of the sleeves, has been commented upon as indicating diagonal loading and a tendency to induce a lateral thrust, corresponding to a diagonal characteristic, but it is feared that those who gave this matter the benefit of their distinguished consideration were too busy to construct a diagonal of the forces, and they therefore failed to penetrate sufficiently into the intricacies of the problem to permit them to arrive at the conclusion that the lateral pressure is merely nominal, due to the fact that the sleeves are of great length as compared with diameter, so that the diagonal of the forces, when expressed in pounds per square inch on the projected area of the sleeves, is resolved into a mere decimal of a unit.

The water pump W4 is of the centrifugal paddle type, and the intake I1 passes in the horizontal plane from the under side of

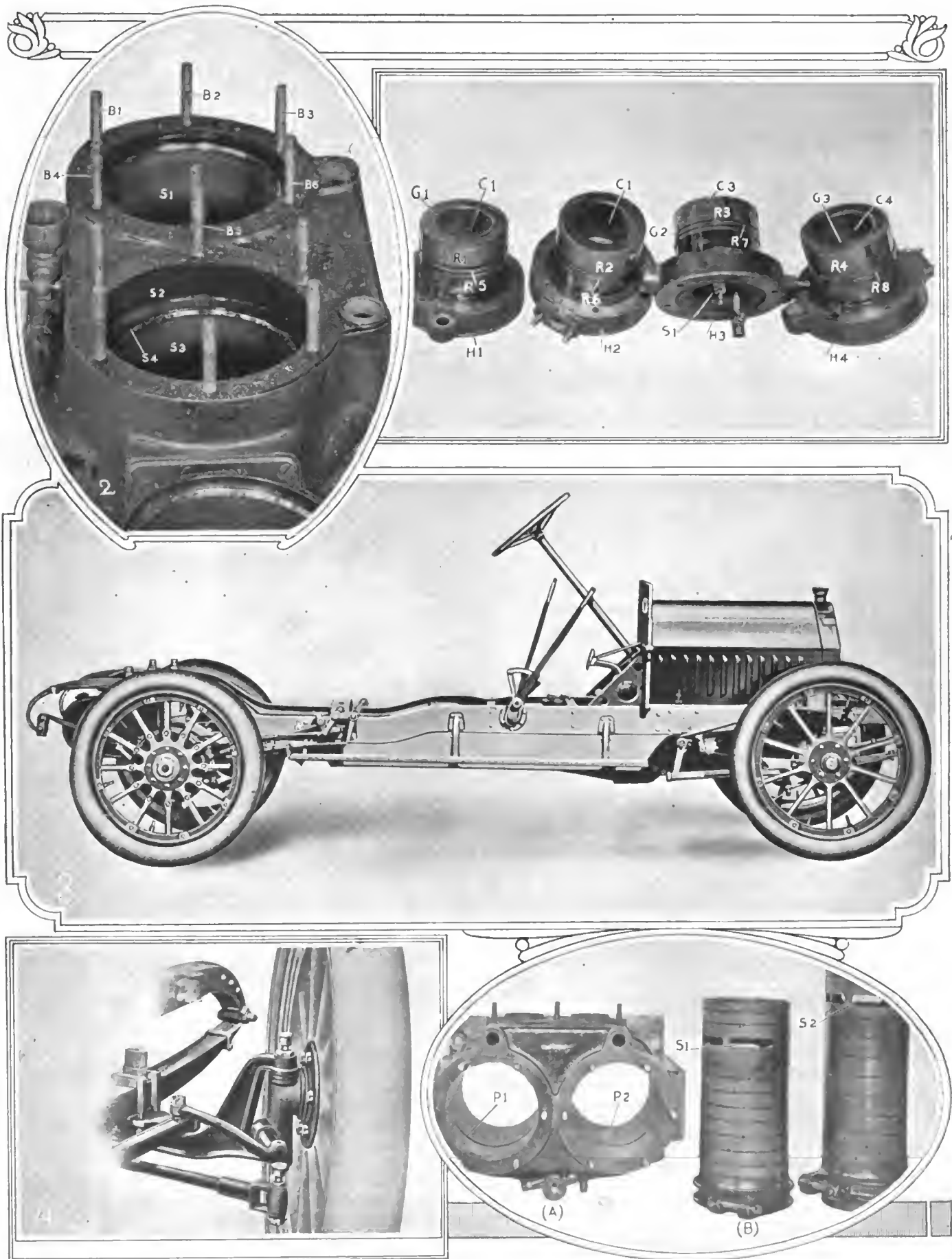

Fig. 2—Showing one pair of cylinders with the sleeves in place and the heads removed indicating the condition of the bearing surfaces at the expiration of the test  
 Fig. 3—Looking at the right-hand side of the Stearns-Knight chassis  
 Fig. 4—Looking at the front axle, showing the method of construction  
 Fig. 5—Showing the four cylinder heads as they were taken off the motor and the condition of the junk rings and other wearing surfaces at the time  
 Fig. 6—Showing one pair of cylinders and one pair of sleeves and the condition of the surfaces at the expiration of a test run



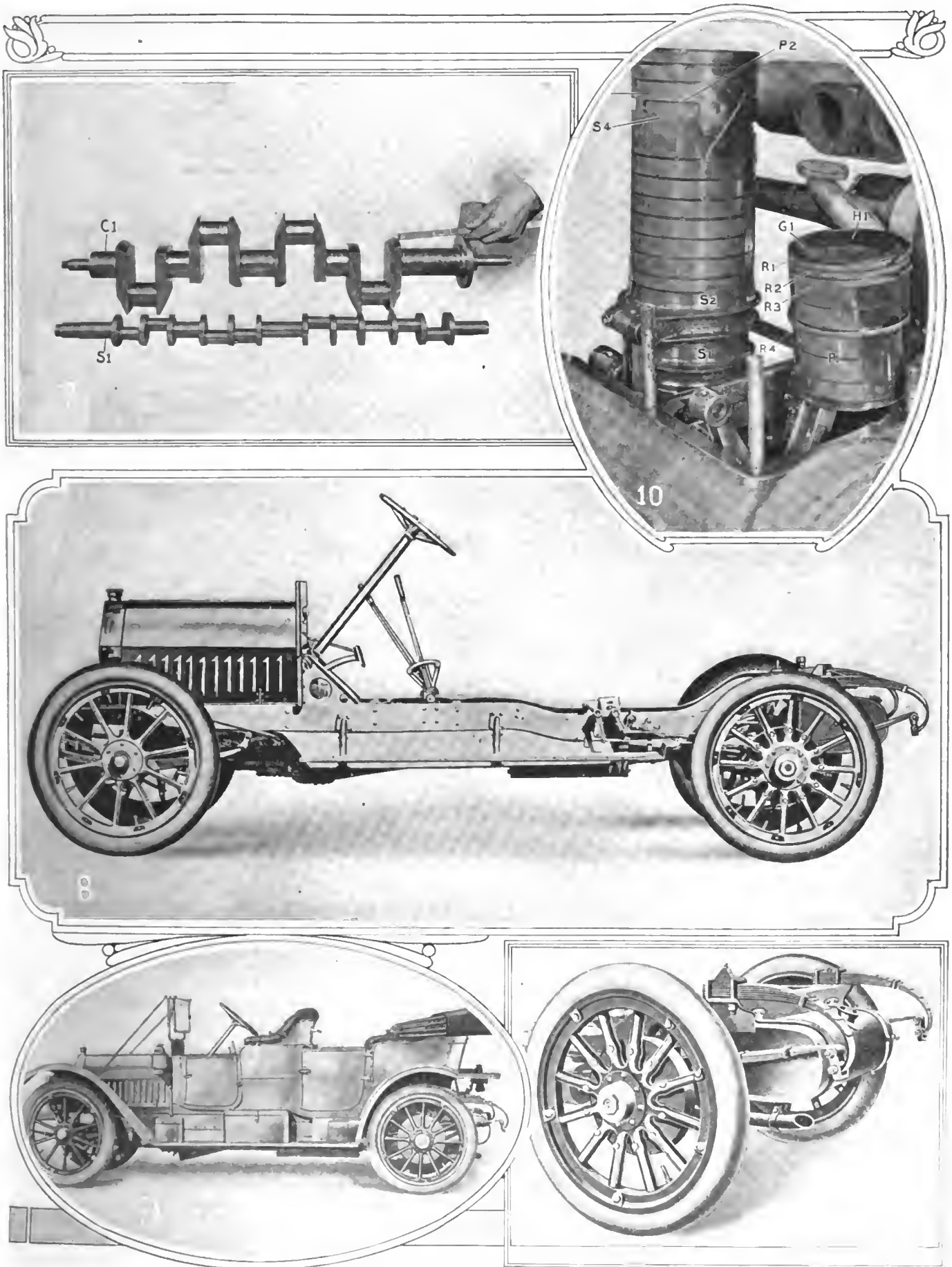
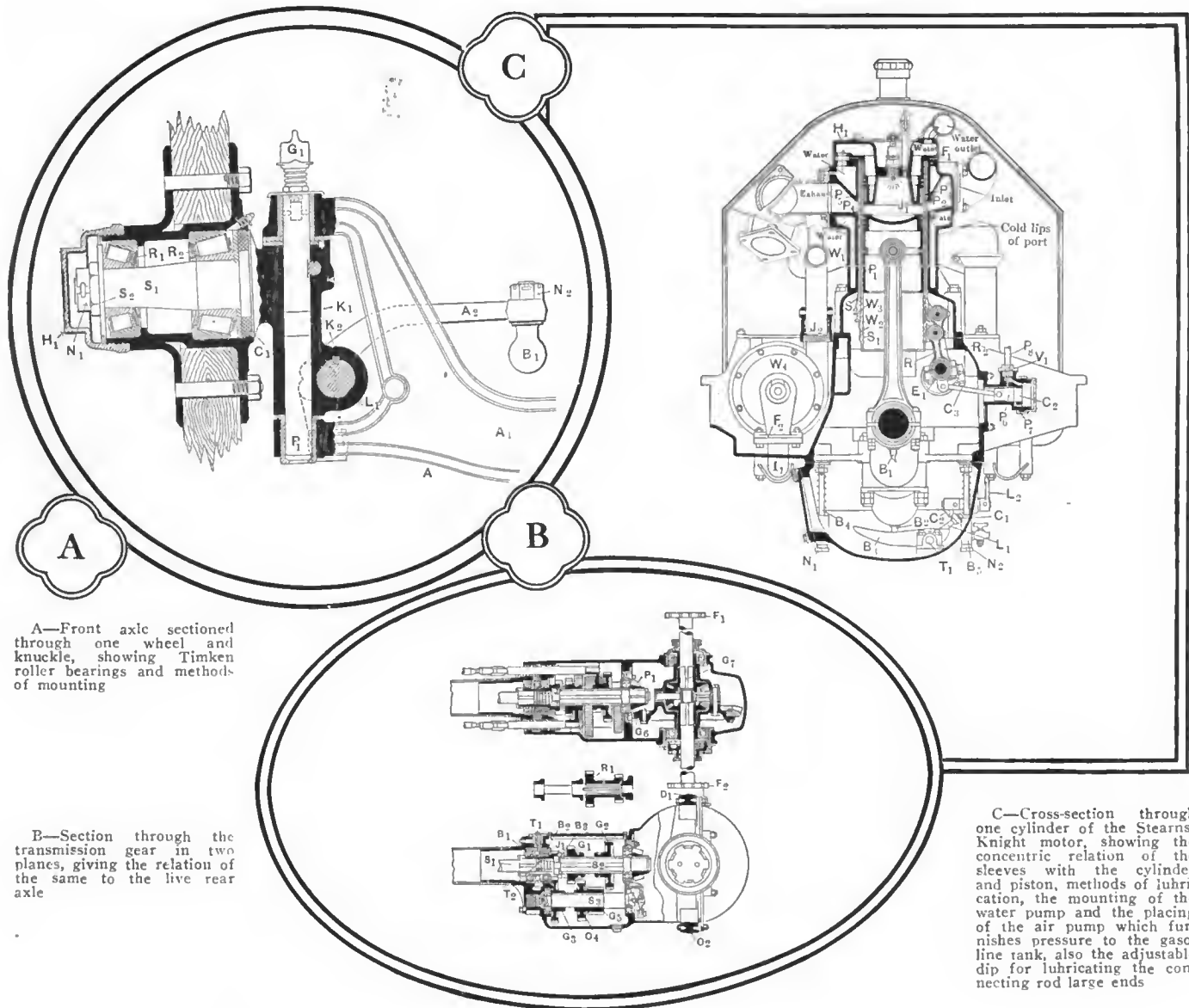

Fig. 7—Presenting the crankshaft and eccentric shaft of the Stearns-Knight motor, showing a bearing on each side of each pin and a 5½-inch bearing at the flywheel end of the crankshaft. Fig. 8—Looking at the left-hand side of the Stearns-Knight chassis. Fig. 9—New Stearns-Knight automobile of the fore-door type with a three-quarter elliptic rear suspension and a half-elliptic front suspension. Fig. 10—Showing the front end of the crankcase with one piston in view and the sleeves in position in the concentric relation with the second piston, photographed at close range to disclose the character of the bearing surfaces and the excellence of lubrication. Fig. 11—Looking at the back of the car, showing the method of suspending the gasoline tank and other details.



A—Front axle sectioned through one wheel and knuckle, showing Timken roller bearings and methods of mounting

B—Section through the transmission gear in two planes, giving the relation of the same to the live rear axle

C—Cross-section through one cylinder of the Stearns-Knight motor, showing the concentric relation of the sleeves with the cylinder and piston, methods of lubrication, the mounting of the water pump and the placing of the air pump which furnishes pressure to the gasoline tank, also the adjustable dip for lubricating the connecting rod large ends

the radiator with an upward sweep at the back of the pump to the axis of rotation thereof. The pump has a flange connection at  $F_2$  and a packed screw joint at  $J_2$  for the outlet. The capacity of the pump has been fixed with particular reference to the performing characteristics of the sleeve type of motor, and one of the most marked characteristics of this motor is indicated by the use of a comparatively small radiator, suggesting that heat loss to the water jacket is relatively a limited quantity, to account for which requires that a further study of the design of the motor be indulged in. When it was at first suggested that a pair of sliding sleeves be placed in concentric relation with the piston in the cylinder of a motor, the state of the art was such that the experts of that time were fearful of the result. They were unable to see wherein a plurality of joints between the flame and the water-jacketed metal could be turned to advantage, and they were wont to point out that the heat absorbed by the sleeves would pile up in the sections thereof, and an over-heated motor would be the result. Chagrin must have been their lot, for in all truth this sleeve type of motor is remarkable for its cold performance, and come to think of it, the elements for cold performance are all present, and now that the proof of this happy characteristic is in ample presence, it requires no great knowledge on the part of anyone to point to the fact. It has long been understood by those who are intimate with motor designing that the only reason why water is used for cooling is because the heat that gets into the section of the cylinder wall must be

coaxed out again, and this is another way for saying that if we can keep the heat from getting into the cylinder wall, to whatever extent this is done, cooling may be dispensed with. That the thinness of the sleeves contributes largely to the good performance is now appreciated, it being the case that there is no difficulty involved in the cooling problem when the walls are thin, since it is in thick walls that heat piles up and resists tapping away. In the further discussion of the thermic relations as they obtain in this motor it will be well to observe that the sunken head, with its water jacketing, shields the sleeves from the fierce glare of the burning gas, and by the time that the piston recedes under the force of the pressure wave the heat wave has fallen to a level that is well within control under the conditions as they obtain in this example. The high mean effective pressure of this type of motor is in a considerable measure accounted for by the influence of the sleeves on the retention of heat, and we may conclude by saying that the fact that a very small radiator suffices for every need is a staunch argument in favor of high mean effective pressure, economy of gasoline consumption, flexibility in the range of performance of the motor, a high co-efficient of stability, resulting in accentuated hill-climbing ability, excellence of the average road performance, absence of noise or knocking, and carrying this idea to the point of throttling the motor to a standstill on a steep grade results in the power dying out without any bucking or other signs of distress.

In the operation of the motor it is the plan to work the ac-



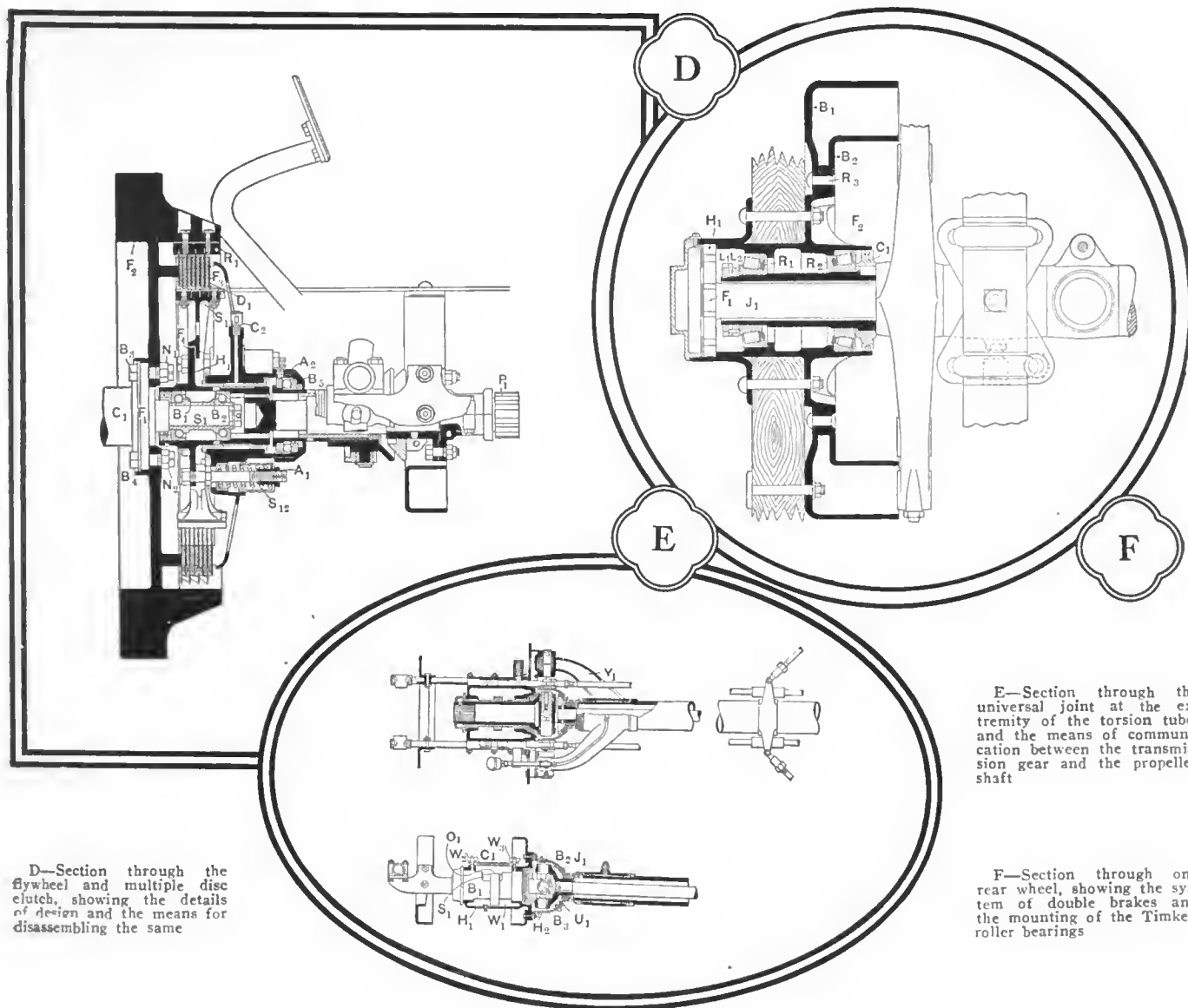

D—Section through the flywheel and multiple disc clutch, showing the details of design and the means for disassembling the same

E—Section through the universal joint at the extremity of the torsion tube, and the means of communication between the transmission gear and the propeller shaft

F—Section through one rear wheel, showing the system of double brakes and the mounting of the Timken roller bearings

celerator for the control of the air and to maintain the spark at the proper position of advance for the most economical result, but it is a noteworthy fact in practice that the motor may be run fast or slow under a variety of conditions of the load imposed with the spark fixed, changing speed by altering the air that is admitted to the carbureter, thus showing that the thermic conditions are on a stable basis. The possibilities in the matter of the control of the motor may be seen by making a study of the chart Fig. M, in which it will be seen that the torque curve takes a pronounced upward trend as the speed is increased, thus indicating that the range of stability has been advanced, and it looks, comparing this chart with the conditions as they are indicated in Fig. N, as if the range of stable performance of the Stearns-Knight motor has been advanced by a measure that is not far from 500 revolutions per minute. It is by no means certain that there has been any sacrifice of performance at the lower range of speeds to get this better performance at the higher speed, and the excellence of the work that the motor does on low speed on a long steep grade is the best foundation for this belief. This same characteristic is of much advantage when the road is heavy and the motor is required to deliver maximum power at the low range of speed for a considerable period of time.

In the lubrication of the motor the connecting rods are provided with buckets B1 and B2, there being one on each large end, dipping into tilting troughs B2, swiveling on trunnions T1,

actuated by levers L1 through cam rollers C1 engaging cams C2, which in turn are actuated by levers L2, of which there is one for each tilting oiler. The motion for the control of the tilting oiling system is imparted by the manipulation of a master lever, which may be placed at any convenient point, as on the dash. It has been found in practice that this method of oiling permits the operator to alter the rate of lubrication to suit the exigencies of service, and to save a motor from smoking when it is doing mild service in town, which is an important matter in these days when the police regulations everywhere cast doubt upon the expediency of generating smoke in the public streets. The gasoline is fed by pressure to the carbureter and thence to the motor, and the pressure in this particular motor is maintained at one pound per square inch through the good office of a piston P6, which plays in a little air cylinder C2 bolted on the face of the crankcase in the vicinity of the eccentric shaft, and motion is imparted to the piston P6 by a connecting rod C3, which in turn takes its motion from an extension of the connecting rod R1 of the long sleeve S1. The little piston P6 in the air cylinder C2 uncovers a port P7 to admit air, and as the piston travels in the direction of the head after it covers this port the air is compressed when it passes by a check valve V1 into a pipe P8, thence to the gasoline tank, but a pressure gauge is placed on the dash for the purpose of showing the extent of the pressure and indicating to the operator of the car that all is well.

Before departing from the cross-section Fig. C it will be to the

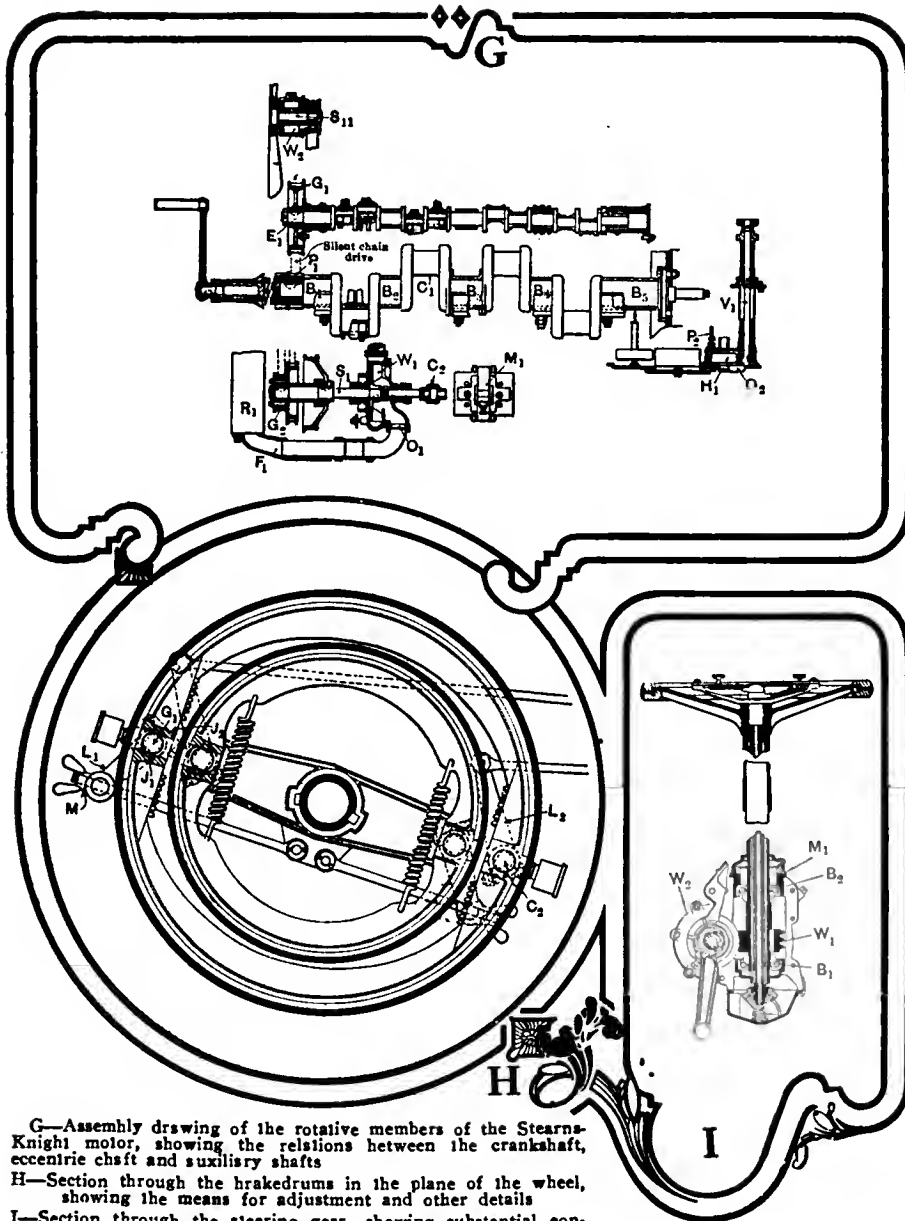

G—Assembly drawing of the rotative members of the Stearns-Knight motor, showing the relations between the crankshaft, eccentric shaft and auxiliary shafts  
 H—Section through the brakedrums in the plane of the wheel, showing the means for adjustment and other details  
 I—Section through the steering gear, showing substantial construction and a means for taking up lost motion

point to call attention to the method of fastening the lower half of the crankcase to its mate by means of long bolts B<sub>4</sub> and B<sub>5</sub>, of which there are six, the arrangement being such that the lower half may be 'dropped down if the knurled holding nuts N<sub>1</sub> and N<sub>2</sub> for each holding bolt are unscrewed, but in order that this plan may be carried to a successful issue the connections for the lubricating system are so contrived that the joints are automatically made or broken, so that the operator is permitted to get at the working parts of the motor without having to consider the breaking of these joints, notwithstanding the fact that all of the lubricating piping is within the crankcase, and the oil is circulated through piping that passes from the lower to the upper half.

### How the Rotative Members of the Motor Are Arranged and Related to Each Other

Referring to Fig. G of the assembly of the rotative members, it will be seen how the crankshaft C<sub>1</sub> rotates in five main bearings B<sub>1</sub>, B<sub>2</sub>, B<sub>3</sub>, B<sub>4</sub> and B<sub>5</sub>, and Fig. J is a working drawing of this crankshaft giving the dimensions, and attention is called to the fact that the crankshaft is of unusually stout construction with a 5 1-4 inch by 2 1-4 inch main bearing adjacent to the flywheel, while the other main bearings are graded off to 3 inches by 2 1-2 inches at the middle, 2 9-16 by 2 1-2 at the front end, and

2 inches by 2 1-2 inches for the intermediate bearing. The connecting rod bearings are 2 1-2 by 2 1-4 inches, and the cheeks of the throws are 1 inch thick by 3 3-8 inches the other way, excepting that the cheeks facing the midship bearings are flanged out to 4 1-4 inches, it being the case that thrust is taken by this bearing only, and the faces are made considerably wider for the purpose of resisting this thrust. What the detailed drawing shows is that the unusually large torquing moment of this type of motor demands particular treatment, and in addition to placing a bearing on each side of each throw the strength of the crankshaft has been enormously increased not only by using a liberal supply of metal under well-directed conditions, but in the selection and use of specification nickel steel as well.

Referring back to Fig. G it will be seen how the eccentric shaft E<sub>1</sub> takes its drive by means of a silent chain from the pinion P<sub>1</sub> to the gear G<sub>1</sub>, and the drive for the auxiliary shaft S<sub>1</sub> is through a silent chain from the gear G<sub>2</sub> to the other half of the pinion P<sub>1</sub>. The shaft S<sub>1</sub> drives the water pump W<sub>1</sub>, the shaft passing through, and the magneto M<sub>1</sub> is driven by the same shaft with a coupling C<sub>2</sub> interposed. The radiator R<sub>1</sub> rests upon a fitting F<sub>1</sub>, and the piping leads from the under side of the radiator to the entering orifice O<sub>1</sub> of the pump. The drive for the fan is by means of a shaft S<sub>11</sub> in a lubricated plain bearing, with an oil well W<sub>2</sub>, the source of power being the auxiliary shaft S<sub>1</sub> with a belt transmission. The eccentric shaft is provided with a plain bearing on each side of each throw, and a further study of this assembly layout lends substance to the impression that great rigidity is aimed at. At the right-hand side of the layout a vertical shaft V<sub>1</sub> reaches down to drive the oil pump O<sub>2</sub>, the latter being of the gear type, but it differs from oil pumps in general in that the two gears are of dissimilar sizes, the smaller of which is on the

end of the vertical shaft, and the large gear serves as a magazine, taking the oil into the housing, delivering it through a circular path to the cored hole H<sub>1</sub> within the gear, and there being a plurality of delivery orifices around the web of the gear, oil is delivered to the pipe P<sub>2</sub> at timed intervals according to the registry of the holes in the web of the gear. It was found in the course of the experiments that even a ball bearing in the fan drive was too noisy to tolerate, and a plain bearing with automatic means for lubrication had to be substituted instead.

From the motor to the clutch, nested in the flywheel as shown at Fig. D, is the course of the torquing increment of the power on its way to the live rear axle, and referring to this clutch it will be seen how it is assembled on ball bearings B<sub>1</sub> and B<sub>2</sub> on the stub S<sub>1</sub> of the crankshaft C<sub>1</sub>, back of the flange F<sub>1</sub>, to which the flywheel F<sub>2</sub> is bolted by means of bolts B<sub>3</sub> and B<sub>4</sub> with locking nuts N<sub>1</sub> and N<sub>2</sub> to maintain tightness. The clutch is of the multiple disc type, with fabric facings F<sub>3</sub> on the metal discs D<sub>1</sub>, and the drive is through the ring R<sub>1</sub>, interrupted by the discs as referred to, to the spider S<sub>11</sub>, which is flanged at F<sub>4</sub> to the housing H<sub>1</sub>, and pressure is exerted on the discs by springs S<sub>12</sub> with adjustments A<sub>1</sub>, by means of which tension may be varied to suit the exigencies of service. The reaction of the clutch spring is

taken care of by the thrust bearing B5, which is also provided with an adjustment A2. Lubrication is handled through the cup C2. One of the important points that this design contemplates is the getting at of the clutch in service, and a study of this section will show that there is compensation sufficient to permit of the removal of the pinion P1, thus freeing it from its mate in a way that will be clear to the reader if he will examine Fig. E of the universal joint in the plane of the yoke Y1, showing how the drive is brought about from the clutch shaft to the joint and thence to the propeller shaft, the latter being in the concentric relation with the torsion tube.

The transmission gear of the three-speed selective type is suspended on the live rear axle, thus composing a part of this unit, and the details of design may best be studied by examining Figs. E and B at the same time. In Fig. E it will be seen that the long bearing B1 is in a housing H1 with an oil well W1 and a ring oiler O1, which is placed to pick up the oil in the reservoir and deliver it on top of the shaft S1. There is a cover C1 over this bearing with wing nuts W2 and W3, which may be backed off at will, thus permitting the operator to gain access to the bearing. The universal joint U1 has large bearings B2 and B3 at the trunnions, and lubricating grease is kept within the universal joint by the retaining ability of the housing H2, which is of spherical conformation with a grease-tight joint J1 between the relating members.

Referring to Fig. B it will be seen that the propeller shaft S1 is supported by annular type ball bearings B1 and B2, and that thrust is taken by the thrust bearing T1. Direct drive is brought about through engaging jaws J1, and the stub shaft is supported by an inserted annular type ball bearing B3, while the thrust of engagement is taken on the thrust bearing T2. The sliding shaft S2 is splined, and the sliding gears G1 and G2 are placed thereon. The lay shaft S3 is in the vertical plane under the prime shaft, and the gears G3, G4 and G5 are put on with splines with a separating tube holding them to their proper centers. The reverse gearset R1, given in a separate sketch, and the bevel drive, with the pinion P1 meshing with the gear G6, are shown in their relation with the differential gearset G7, with the jackshafts terminating in square ends, mounted on annular type ball bearings, ending in flanges F1 and F2 at the extremities where the dog drive engages the hubs of the wheels, thus delivering the power thereto under conditions of great flexibility. The live rear axle is of the Stearns type, with solid I-section forging, yoking around the differential at D1 and D2 in the customary way.

By referring to Fig. F it will be seen how the jackshaft J1 is flanged F1 at its extremity and engages the hub H1 of the rear wheel, and a further examination of this section will show the use of Timken roller bearings R1 and R2, held in place by locking washers L1 and L2, with a closure C1 at the back to keep foreign matter out. The flange F2 of the hub is extended to take the outer brakedrum B1 on one side and the inner brakedrum B2 on the other, they being clamped to the hub flange on finished faces by rivets R3.

To get an idea of the details of the two sets of expanding brakes in the double drums as they are bolted to the rear wheels it will be necessary to examine Fig. H, which is a partly sectional

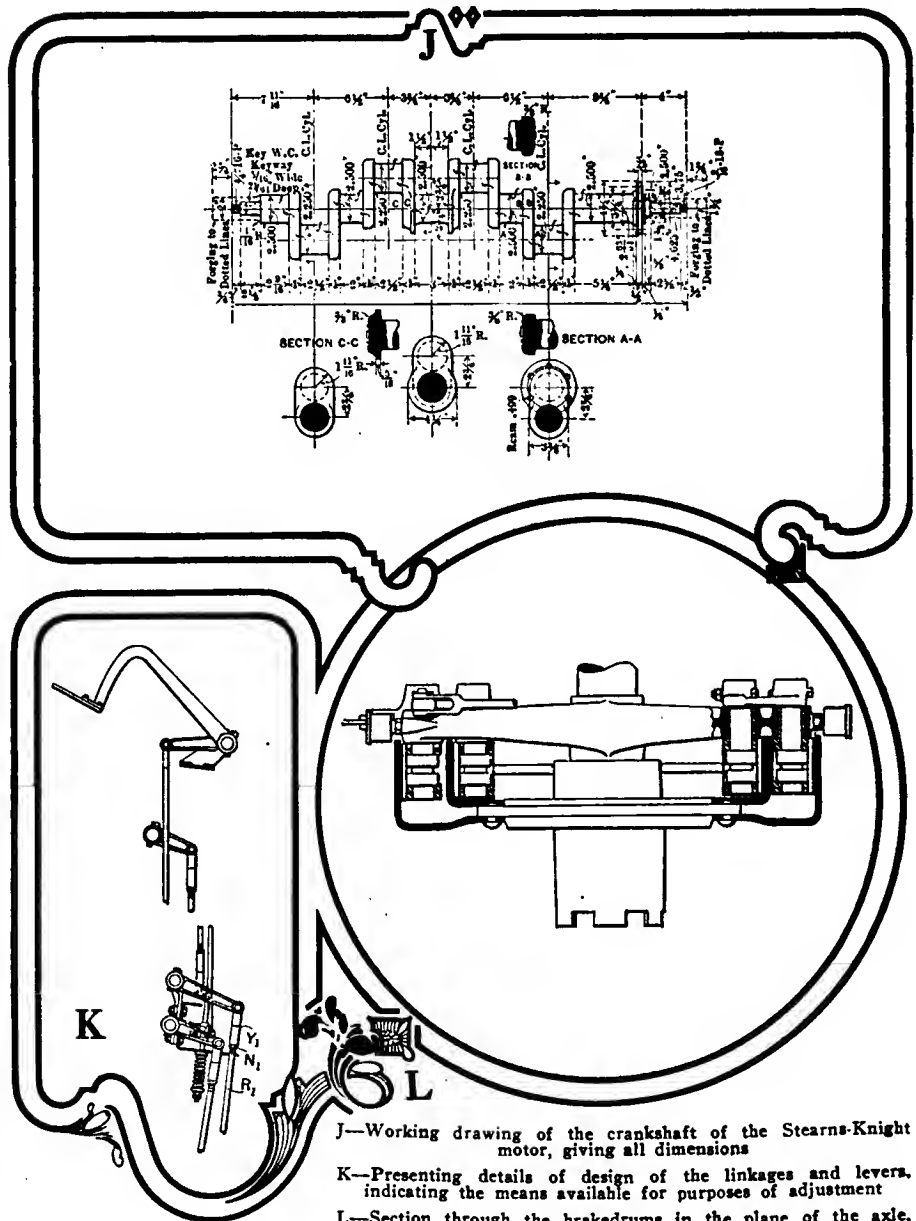

J—Working drawing of the crankshaft of the Stearns-Knight motor, giving all dimensions  
 K—Presenting details of design of the linkages and levers, indicating the means available for purposes of adjustment  
 L—Section through the brakedrums in the plane of the axle, showing the substantial bearings and other refinements

plan in the plane of the wheel and the section Fig. L in the plane of the axle. It will be seen in Fig. H how the adjustment mechanism M1 actuates a lever L1 with a cam C1 pressing against the jaws J1 and J2 forcing the shoes outward, and looking at the diametrical opposite side of the outer brake it will be seen how the lever L2 actuating the cam C2 engages the brakes. The inner brakes are adjusted in precisely the same way, the only difference being that the mechanisms are reversed. Grease cups are placed at points of vantage, the idea being to prevent wear and to save noise.

Fig. K shows some details of the linkages and the levers and the shape of one of the pedals with adjustable yokes Y1 for the rods R1, with locking nuts N1 at every point.

Referring to the front axle A1 in Fig. A, of the I-section, attention is called to the knuckle K1 with a pin P1 and a grease cup G1 placed at the upper end for purposes of lubrication, and to the knuckle spindle S1 with Timken roller bearings R1 and R2 in the hub with a safety washer S2 held in place by a locking nut N1 with a hub cap H1 over all, and a closure C1 at the back to exclude dirt. This axle is of the Elliott type, and the distance between the yoke supports is adequate for every end. The steering arm A2 is a taper fit in the knuckle lug L1, and it is prevented from turning by a key K2. The extremity of the steering arm terminates in a large diameter ball B1, which is of hardened

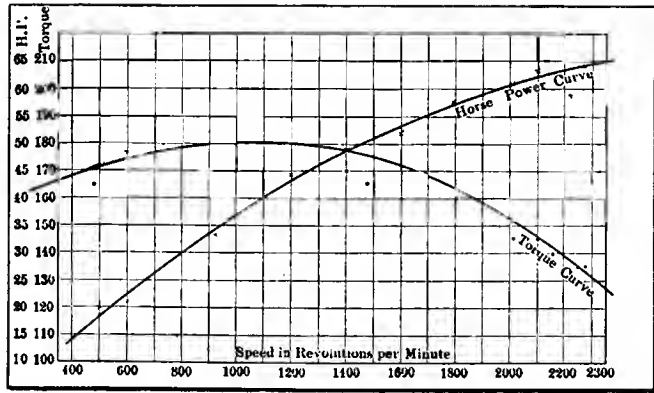

M—Torque characteristic of the Stearns-Knight motor given to be compared with the torque characteristic of the Stearns poppet valve type of motor

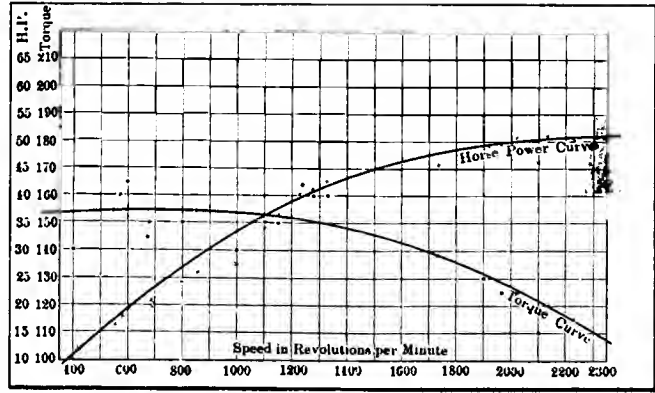

N—Torque characteristic of the Stearns poppet valve type of motor given for purposes of comparison with the torque characteristic of the Stearns-Knight type of motor

steel, with a press fit in the enlargement of the knuckle arm pulled to tightness by a locking nut N2.

The steering post is shown in section Fig. I, with a worm W1 engaging a wheel W2, with means for adjustment between cup and cone ball bearings B1 and B2. For purposes of adjustment the mechanism M1 with threaded portions is provided. The spark and throttle levers are in concentric relation within the tube, and the steering wheel is of large diameter with a fluted rim, securely fastened to a substantial dished spider.

### Why the Stearns Design Had to Be Revamped to Accommodate the Stearns-Knight Motor

Despite the excellence of design and construction of the Stearns poppet valve type of motor as it was refined through several years of practice, it was found that the new Stearns-Knight motor delivers considerably more power and performs with an entirely different characteristic in hill climbing and on long stretches of bad roads. As will be well appreciated by those who have given the matter thought, the crankshaft and other rotative members in the torquing system of an automobile, if they fail at all, will do so during the period of maximum power delivery at slow speed. It is in the ability of the Stearns-Knight motor over the Stearns poppet valve motor to deliver a larger measure of torque at the lower speed that required the reconsideration of the chassis designing problem, and the whole matter was finally disposed of by refining and strengthening the Stearns chassis to suit the new conditions, but for the purpose of clearness here it is considered desirable to give the results of tests of the Stearns poppet valve motor and of the Stearns-Knight motor.

The Stearns-Knight motor, which the author examined and photographed after taking it apart, has cylinders with a bore of 4¼ inches and a stroke of 5½ inches, making the cubical displacement 312.082 cubic inches, which would give an A. L. A. M. rating of 28.9 horsepower. The power of this motor as determined by test on February 3 and 4, 1911, was as follows:

PRONY BRAKE TEST OF THE STEARNS-KNIGHT SLEEVE VALVE MOTOR.

R. P. M	Pounds.	H. P.
480	165	15.8
600	175	21
930	180	33.5
960	180	34.5
1,200	185	44.4
1,335	170	45.3
1,360	180	48.9
1,400	170	47.6
1,440	175	50.4
1,485	165	49
1,600	160	51.2
1,620	170	55
1,800	160	57.6
1,950	155	60.5
2,010	150	60.3
2,050	150	61.5
2,100	150	63
2,125	145	61.6
2,125	140	59.6
2,175	140	60.9
2,250	135	60.7
2,280	135	61.5
2,290	140	64.1
2,380	130	61.8

Get-away 165 lbs. torque.

PRONY BRAKE TEST OF THE STEARNS POPPET VALVE MOTOR.

R. P. M	Pounds.	H. P.
400	140	11.2
565	155	17.5
590	160	18.7
600	165	19.8
690	145	20
690	150	20.7
800	150	24.8
850	155	27.2
1,000	140	28
1,150	150	34.5
1,200	150	36
1,235	163	40
1,270	160	40.6
1,315	160	42
1,730	138	45.5
1,915	130	49.7
1,965	125	49.6
2,015	125	50.6
2,100	110	46.2
2,140	120	51.3
2,220	115	51

The poppet valve motor has four cylinders with a bore of 4½ inches and a stroke of 4¾ inches, with an A. L. A. M. rating of 32.4 horsepower. It will be seen that the poppet valve motor is of larger bore than the four-cylinder Stearns-Knight motor, and comparing the power of the two motors at one point only for the moment, the Stearns-Knight motor delivered 44.4 horsepower at 1200 revolutions per minute, whereas the Stearns poppet valve type of motor delivered 36 horsepower at the same speed, and the Stearns-Knight motor delivered a torque of 170 pounds, whereas the poppet valve type of motor delivered a torque of only 150 pounds at 1200 revolutions per minute. The maximum power of the Stearns-Knight motor was 64.1 horsepower at 2290 revolutions per minute, and the maximum power of the poppet valve type of motor was 51 horsepower at 2220 revolutions per minute. In a further comparison of the characteristics of the two motors reference may be had to the speed torque curves, as shown in Figs. M and N, which is the most fitting way of disposing of the matter.

## Proper Form of Carbureter Cock

It is not uncommon, in connection with carbureters, to observe that the cocks are of the sort usually found on gas fixtures and other work in which the ills of vibrations are not figured upon. For carbureters it is scarcely to be expected that the ordinary form of cock will do the work without giving a certain amount of trouble, and the proper form of cock should be one provided with a spring-locking device, so contrived that the cock cannot jar loose. The lock consists of a pin in the stem of the valve which engages a nick in the housing. When the valve is turned the spring compresses enough to allow the pin to slide out of the notch in the housing without any trouble at all. The crank on the stem is also weighted, and the weight hangs downward when the cock is in the closed position. This is an additional safeguard that is of good value, and the cost is really nothing extra. If all cocks are so devised, it is then that the autoist can see, at a glance, if the cocks are opened or closed.

# Columbia Out with Knight Motor

## Holding Closely to the Latest English Version

*Illustrating and describing the Knight motor used in the new high-powered Columbia car for 1912, showing close agreement between Columbia practice and the work that is being done in England under the direction of Charles Y. Knight, of Coventry, the modifications, such as there are, being in the chassis, for the purpose of bringing the same up to the new requirement in view of the characteristic of the sleeve type of motor and for the purpose of harmonizing the existing relations. The finished article is designed to conform to the demands of American road work, following along the lines that are characteristic of Columbia automobiles as they are known to the industry.*

**S**IGNIFICANT of the trend in motor work, the new Columbia-Knight motor as made by the Columbia Motor Car Company, of Hartford, Conn., is here presented, the motor being of the four-cycle type with cylinders cast in pairs, with an A. L. A. M. rating of 38 horsepower, but the power delivery will be that due to a bore of a 4.7-8 inches and a stroke of 5.1-8 inches. The actual power, according to tests made, ranges between 70 and 85 horsepower. While the motor follows the general lines as practiced under the direction of Charles Y. Knight in his work abroad, an effort has been made to reduce this practice to conform to the requirement from the point of view of this company, and Charles E. Reddig, chief engineer of this company, went into the matter at some length with Inventor Knight, and agreement was reached between them to the furtherance of the plan. The experiences that were gained at Coventry in the working out of the Daimler-Knight motors were taken advantage of in the designing of the Columbia-Knight motor, and in the materials as they are used in the newer effort, there is close agreement with the plans that have served abroad.

The details of design and construction of the new motor may be clearly appreciated by an examination of Fig. O, showing a section through one of the cylinders at right angles to the plane

of the crankshaft. The piston P1 is shown at the top of the stroke, and the connecting rod C1 of the I-section has a split enlargement, and clamping of the crankpin bearing C2 is accomplished by means of four through-bolts B1, etc., using plain bearings and white metal lining. A dipper D1 scoops oil out of the adjustable receptacle S1, and the excesses of lubricating oil fall down into the oil reservoir R1, and the quantity of oil present in this reservoir is indicated by the position of the tell-tale T1, which is actuated through the buoyancy of the float F1 in the manner as shown. Referring to the sleeves in their concentric relation to the piston in the cylinder, the long sleeve S2 on the inside is actuated by the connecting rod C3, and the short sleeve S3 between the long sleeve and the cylinder is actuated by the connecting rod C4, both connecting rods being given reciprocating motion by the eccentric shaft E1, and power is transmitted to this shaft from the crankshaft by means of a silent chain, engaging suitably contrived gears placed in an oil-tight housing at the front end of the motor. Recognizing the necessity of maintaining good conditions of lubrication of the sleeves, the chamber C5 is fashioned in the crankcase, and the oil that reaches this chamber is guided in its upward travel reaching the point O1 for the lubrication of the outer sleeve, and the point O2 for the lubrication of the inner sleeve, and the oil thus applied to these surfaces is drawn up between the sleeves and between the outer sleeve and the cylinder wall, maintaining an even coat of the lubricating oil over all of the surfaces, so regulated, however, that a smoking exhaust is avoided. Some of the lubricating oil reaches the surface S4, and experience shows that the junk ring J1 is maintained in a good state of lubrication at all times, but since all of the lubricating oil that reaches the junk ring surfaces must come into contact with the packing rings above the junk ring it goes without saying that these packing rings are properly lubricated also.

It will be seen how the spark plugs P2 and P3 are screwed into the detachable cylinder head, and attention is called to the water jacket W1 of the head, circulating water all around the spark plugs, thus overcoming one of the little difficulties that was

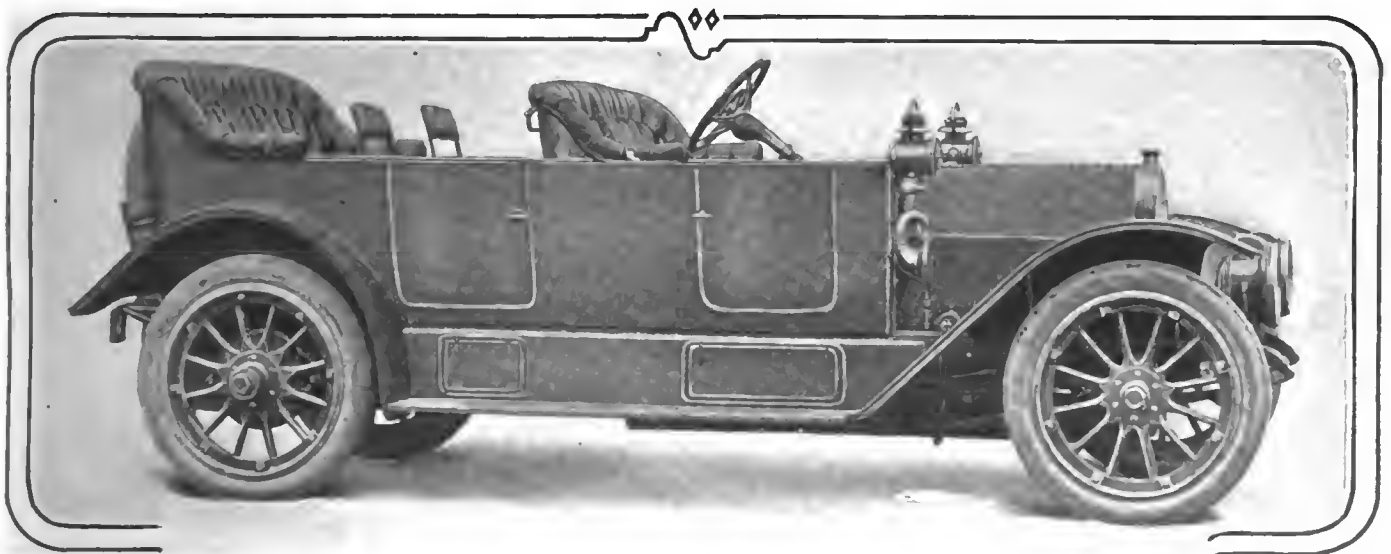

Columbia-Knight touring car with seating room for seven passengers, which plan is carried out from the appearance point of view in the several models that are placed at the disposal of the patrons of the company



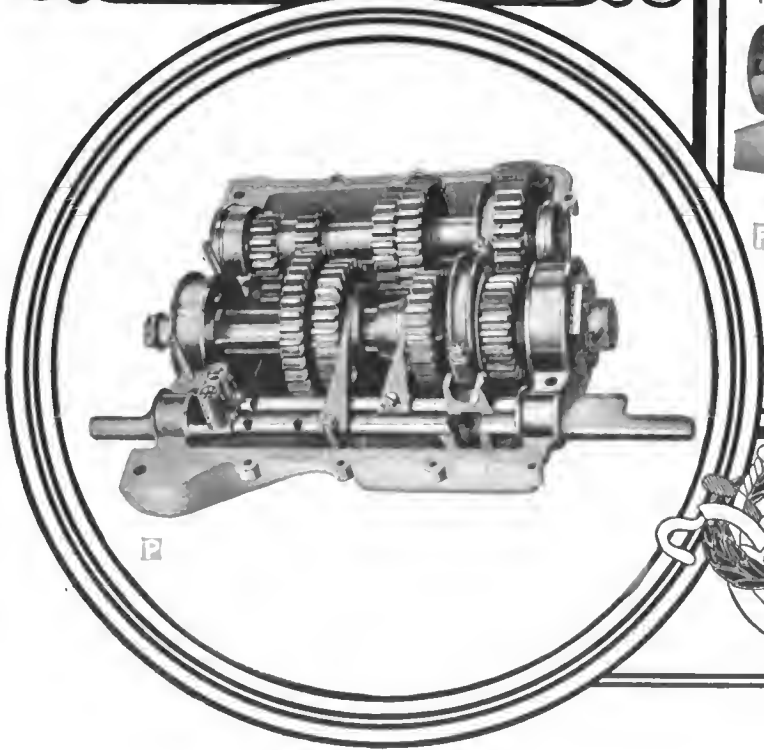
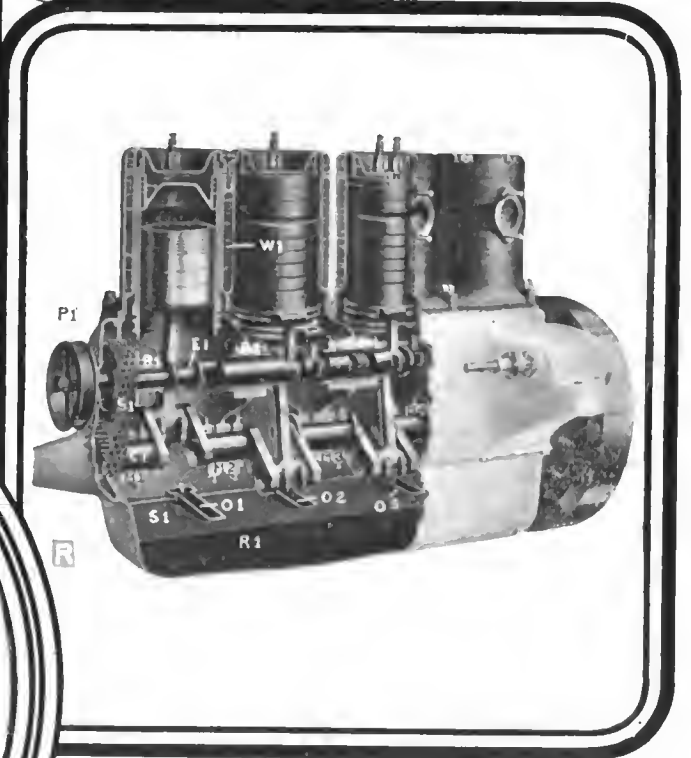
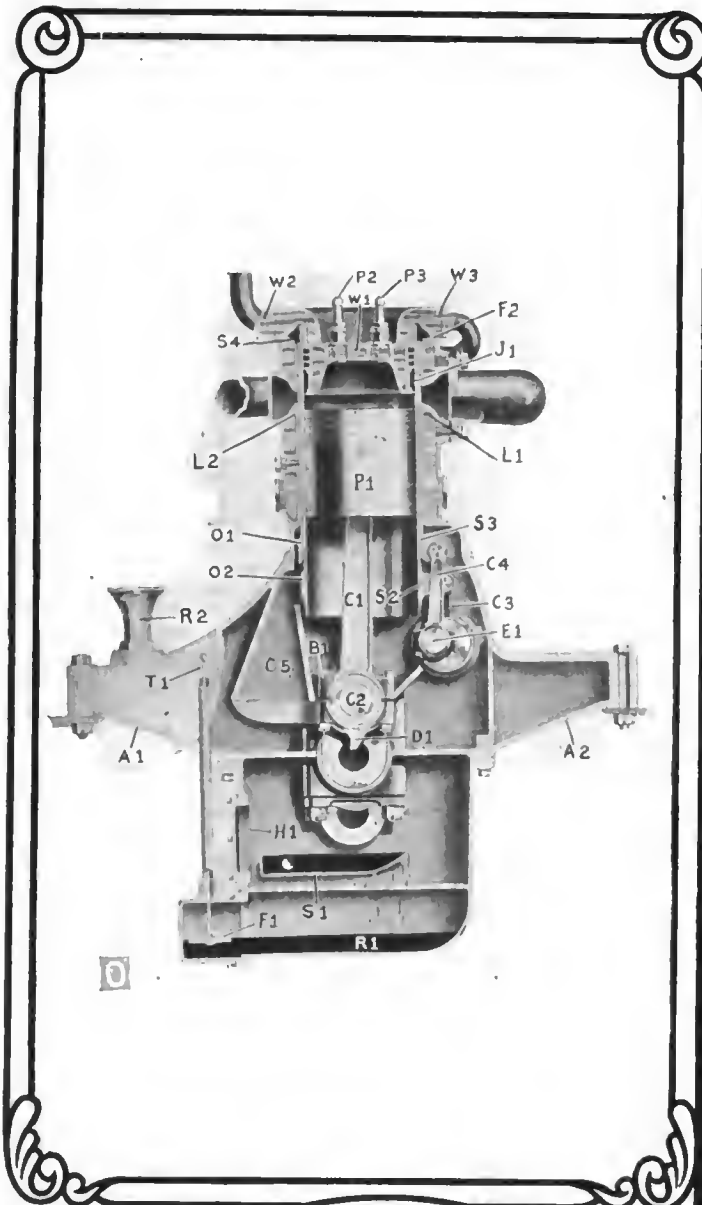

Fig. O—Section through one cylinder, showing the construction of the arms, scheme of oiling and valve mechanism

Fig. P—Looking into the four-speed selective type of transmission gear, showing the use of annular type ball bearings

Fig. Q—A pair of sleeves taken from the motor showing the slotting for the ports and grooving to accommodate lubricating oil

Fig. R—Elevation of the motor in part section, showing the relative position of the eccentric to the crankshaft and the silent chain drive between them

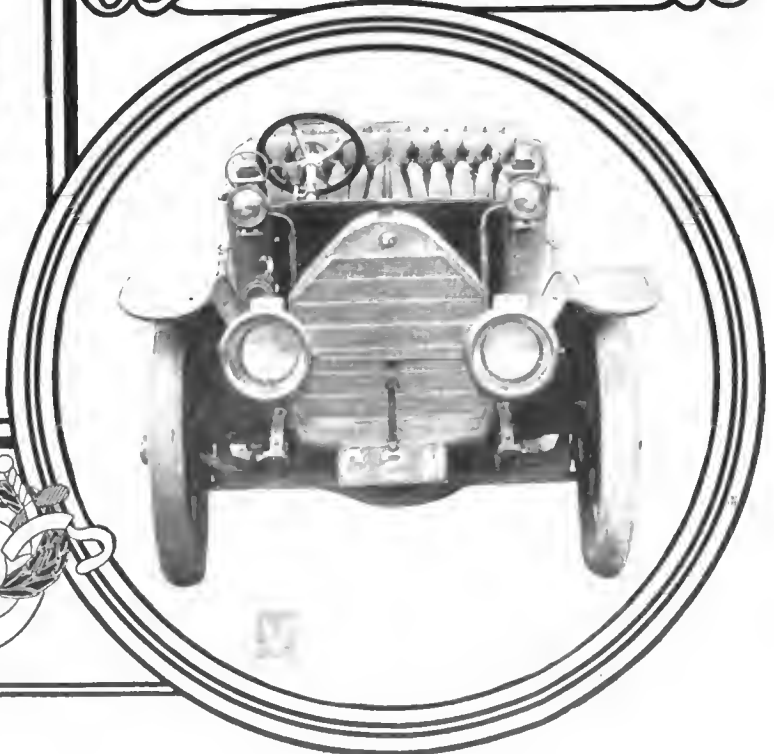
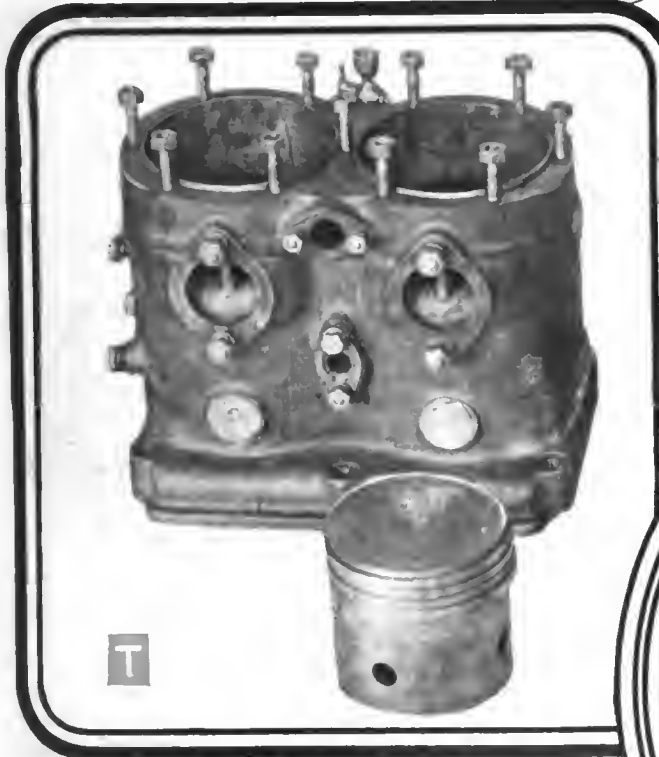
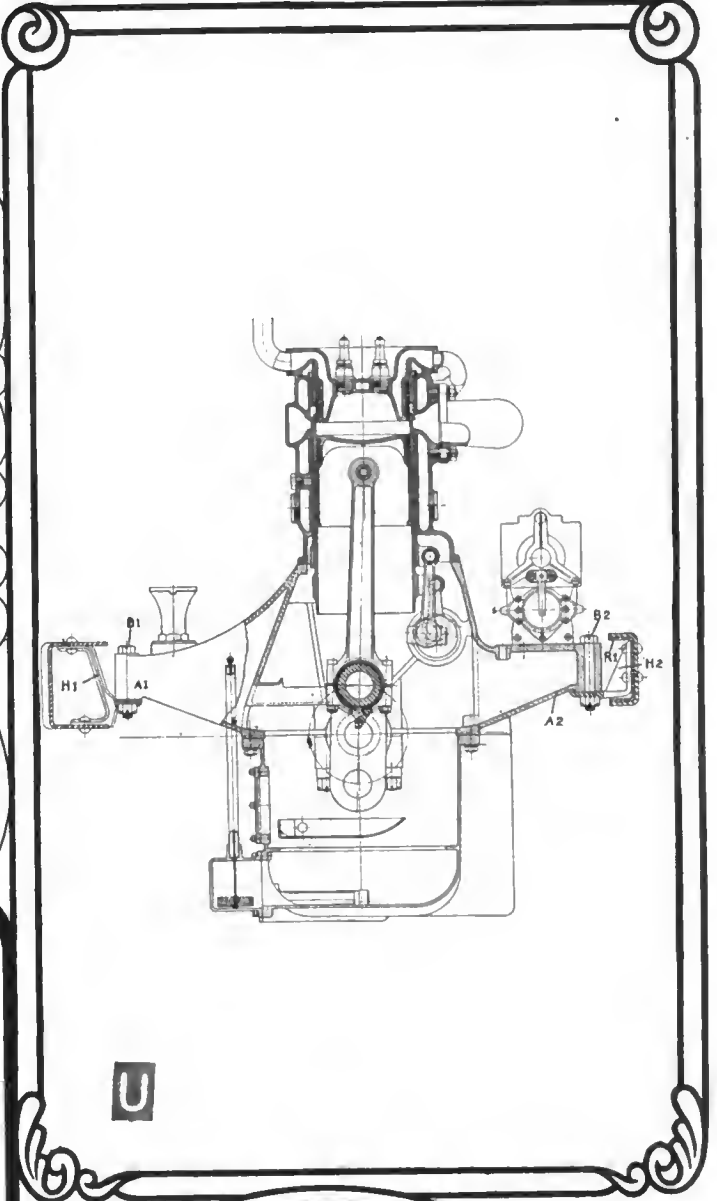
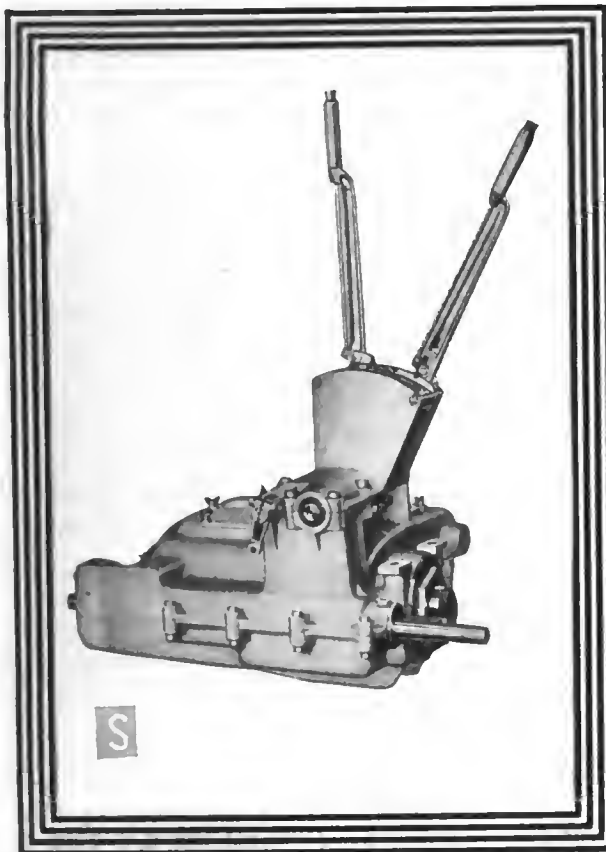

Fig. S—Exterior view of the four-speed transmission gear, showing the arrangement for the levers as they come through the floor in the middle of the body.

Fig. T—One pair of the twin cylinders of the motor and one piston also showing the holding bolts for the cylinder heads

Fig. U—Section of the motor through a cylinder, taken from the drawings, showing the uniformity in thickness of the walls and design features throughout

Fig. V—Front end of the Columbia-Knight automobile, depicting the general appearance of the car





formerly experienced in the Knight type of motor, resulting in the melting out of the spark plugs after a certain time in service. A further examination of the water jacketing shows that the lips L<sub>1</sub> and L<sub>2</sub> of the inlet and exhaust ports have been carefully looked after with a view to maintaining proper conditions of cooling, and the passageways for the incoming mixture and the exhaust products are of smooth and symmetrical shape. In this design of Knight motor the water connections W<sub>2</sub> and W<sub>3</sub> are flanged to finished faces on the sides of the cylinder heads, rather than taking a position on the top of these heads. In the designing of the cylinders, some of the early difficulties in the foundry have been overcome by a closer attention to detail in the matter of coring, and it will be seen how the cylinder heads are bolted to finished faces F<sub>2</sub>, making a "ground" joint, to the elimination of packing, and the difficulties that are suggested by its use. The motor arms A<sub>1</sub> and A<sub>2</sub> are cored and the breather R<sub>2</sub> is shown screwed into a boss on the top side of the arm A<sub>1</sub>. Access is had to the crank chamber through hand-holes H<sub>1</sub>, for which covers are provided.

Referring to Fig. R of the motor in perspective with a part of the crankcase cut away and three of the cylinders shown in section, it will be seen how the eccentric shaft E<sub>1</sub> takes its power from the crankshaft C<sub>1</sub> through the silent chain S<sub>1</sub>. The crankshaft is provided with main bearings M<sub>1</sub>, M<sub>2</sub>, M<sub>3</sub>, M<sub>4</sub>, M<sub>5</sub> and M<sub>6</sub>, the latter two of which do not show in this illustration, being covered up by the shell, and the eccentric shaft is also provided with bearings B<sub>1</sub>, B<sub>2</sub>, B<sub>3</sub>, B<sub>4</sub> and B<sub>5</sub>, the latter two being also hidden by the shell. The crankshaft is of unusually large diameter, bored hollow, and considering the use of a bearing on each side of each throw, and the rigidity of the bearing supports, it will be seen that the designer has filed his brief for rigidity in a manner consistent with the power characteristic of this type of motor. This view shows the commodious oil reservoir R<sub>1</sub>, and the positions of the tilting oil troughs O<sub>1</sub>, O<sub>2</sub>, O<sub>3</sub>, there being four, also a screen S<sub>1</sub> between the oil troughs and the body of oil below, it being the idea not only to carefully regulate the supply of oil to the several bearings, but to filter and clean the same as it is directed back into the reservoir. This illustration affords an excellent idea of the general appearance of the motor, there being a certain symmetry of the exterior of the cylinders, and the crankcase is extended up to meet the somewhat shortened cylinders, thus giving an appearance that is at variance with common practice in motors in general. In this view it will be seen how the water jacket separates the walls W<sub>1</sub> between the pairs of cylinders, this being a bid for uniformity of cooling of the cylinder walls at every point, and in this connection attention is called to the small amount of clearance that has been found practicable, notwithstanding the fact that in the earlier practice of the British Daimler Company the piston was given a clearance of as much as .012 of an inch, which considerable amount of clearance was reduced from time to time, until to-day it is not uncommon to see these motors operating with the piston clearance reduced to .004 of an inch. This phase of the designing problem led to another practice that has proved to be efficacious, in which the pistons are backed off, excepting on the pressure zones, and in view of a desire to limit the reciprocating weight to the greatest possible extent, this backing off idea lent facility to the plan, since it permitted of making the pistons so thin of wall that they might deflect a little at the instant of maximum pressure; but this makes no difference at all in the operation of the motor, since the taking on of a slightly elliptical shape is compensated for by the amount of the backing off, which permits of holding to a sufficient clearance for all working purposes, and the gain is marked in the direction of reducing the secondary moments, thus making the running balance all that it should be. In this motor, as the illustration shows, the driving of the rotative members is by a silent chain for the eccentric shaft, including the magneto and the water pump. The only drive that is not by the silent chain is that of a fan which is by a belt from the pulley P<sub>1</sub>.

In the sectional drawing U, the magneto M<sub>1</sub> is shown resting

upon a finished face on the arm of the motor at the right side, and it will be seen how the magneto comes in the vertical plane above the top flange of the sidebar. This is a direct bid for accessibility of the magneto, and a further examination of this reproduction of a working drawing adds to the conclusion that the designer had in mind the desirability of affording access to every vital part, rather with the expectation that much unnecessary tinkering may be avoided if the operator can see the parts and observe of their condition. In other respects this reproduction of the working drawing shows nothing beyond that which can be seen in the section O, excepting that it does bring out very clearly the perfect uniformity of the walls at every point and the freedom from the bunching of the metal. This method of designing produces better castings with greater ease of making them, and the number of "wasters" that will abound under foundry conditions are reduced to such a low level that the difficulty involved and cost of production of the castings are on a favorable basis. Before departing from this illustration, attention is called to the hanger, or bracket, H<sub>1</sub>, attached to the arm A<sub>1</sub> by means of a holding bolt B<sub>1</sub> for the suspension of the motor at the left side, and to the somewhat different shaping of the hanger H<sub>2</sub> attached to the arm A<sub>2</sub> by means of a holding bolt B<sub>2</sub>, and to the reinforcement R<sub>1</sub> of the chassis frame at this point.

One of the pairs of cylinders separated from the motor is shown in Fig. T with one of the pistons setting in front of it, and a pair of the sleeves as they came out of one of these cylinders is presented in Fig. Q. It will be seen how the pistons are depressed in the heads, and attention is called to the grooving of the sleeves and to a series of small holes drilled through their sections, it having been found in practice that it is better to relieve the lubricating oil at certain points and to afford storage pockets for the excesses thereof rather than to attempt to maintain an unbroken film for the whole pressure area of each sleeve. It is more than likely that this series of grooves as they obtain in the sleeves retard the upward migration of the slowly-moving body of oil and in this way lubrication is rendered stable, and the probability of an excess of lubricating oil getting into the chamber, fouling the mixture and causing a smoking exhaust, is done away with.

One of the cylinder heads is shown in Fig. W tilted to bring into view the cavity C<sub>1</sub> within, and to show the joint J<sub>1</sub> of the junk ring. Fig. Z gives another view of one of the cylinder heads, bringing into view the pair of packing rings above the junk rings, also the holes for the holding bolts, the latter being clearly shown in the cylinder heads in Fig. T. One of the connecting rods that impart motion to the sleeves from the eccentrics are shown in Fig. X, and one of the connecting rods which are used to impart reciprocating motion to the pistons is offered in AA. The crankshafts, together with the eccentric shaft, are shown in Fig. Y.

#### Other Important Matters in Relation to the Columbia-Knight Motor

Among the details of design and construction of the motor, there is perhaps no point of greater importance than that as represented in the fact that the cylinder castings and the castings of which the sleeves are made are produced from Swedish iron. The timing of the motor may be varied over a broad range at the will of the operator, so that in this respect this type of motor is without limit, and in the matter of compression, while the motor is "soft" to crank, the torque characteristic indicates that it is on an increasing basis as the speed increases, receding only after the speed reaches practically the working maximum, as this point in the performance is dictated from considerations of lubrication involving the piston travel as it is measured in feet per minute. With every advantage in the direction of favorable timing, including the use of large ports and water-jacketing around the ports, it is found that the motor scavenges advantageously and that the effort required in cooling recedes to a low level, and it is in these directions that evidence comes of

the fact that the motor should deliver a large measure of power per unit of displacement, performing under wide conditions of flexibility, but the point that seems to be of the greatest moment lies in the fact that service does not seem to induce a condition of leakage with its attending loss of power. The accumulation of carbon in the combustion chamber is at a very low rate, and the carbon that gets between the faces of the sleeves is mixed with lubricating oil, and all of it that remains on the surfaces fills in the interstices of the metal, serving as a lubricant on the same principle that graphite is employed in cylinders for lubricating purposes.

The ignition system is the Bosch double outfit with two sets of spark plugs.

From the motor through the clutch to the four-speed selective type (including reverse) transmission gear, as shown in Fig. S, is through rugged mechanism characteristic of last year's Columbia practice, and the nesting of the gears is shown in Fig. P, in which it will be observed that the prime and lay shafts float on annular type ball bearings, the latter being nested in protective housings with closures to retain the grease used in the lubrication of the ball bearings, keeping out foreign matter, and in the shaping of these housings they are so flanged and otherwise provided that the projected area of the pressure surface against the aluminum of the case is maximum and a liberal surface is provided in the planes of thrust. The arrangement of the transmission gear amidship and the placing of the control lever with the emergency brake lever in the center of the body, to be operated with the left hand, leaves a free entrance into the front seats of the car from either side, but it is optional with the purchaser to have the levers placed at the right side in the conventional way. From the transmission gear through the propeller shaft to the live rear axle is the normal course of the torque of the motor, and the axle, being of the full-floating type in a malleable iron housing, shaped for strength, built up in conjunction with tubes under conditions of hot riveting, promises to sustain under the load and road conditions adequately for the end. Access may be had to the bevel drive of the differential housing through commodious bolted-on covers. The differential housing is drop-forged. The pinion and pinion shaft are forged integral, mounted within a cage upon Timken short-series bearings, and may be removed bodily. The bevel drive and differential gear also float on Timken conical roller bearings. The plan of resisting torsion involves the use of a triangular "U"-section pressed steel member tied to top and bottom of axle housing, and leading forward to a flexible connection at a suitably contrived cross bar. The brakes are of large diameter on the rear wheels, and compensation is through a whiffletree transmitting the effort by rods to pedal and lever. The wheels are 36 inches in diameter, and the wheelbase of this model is 129 inches.

The general appearance of this car, looking at the front, is shown in Fig. V, and the I-section front axle of the Elliott knuckle type is in plain view with substantial drop-forged knuckles and stout knuckle arms with a cross rod in the protected position back of the axle, and a straight drag rod leading to the steering arm interpreting the effort of the driver exerted on the steering wheel in the maneuvering of the car. The axle is of the drop type forged in one piece with integral perches for the springs, and the half-elliptic springs in front are designed in view of the condition of constant loading as represented by the motor for the most part, care having been taken to fix the load per inch of deflection of the front springs within the zone of stability, remembering that any pitching that is induced at the front end of the car complicates the body movement at the back, making it extremely difficult for the designer to promise easy riding qualities. Having fixed the spring condition at the front on the basis of an even platform, it remained for the designer to so fashion the back springs that the vertical oscillations would be on an agreeable basis, perhaps in the neighborhood of one and a fraction per second. The importance of utilizing the large amount of power that is promised by the use of

the Knight sleeve type of motor has made it necessary to study the distribution of weight in the chassis, and account has been taken of the fact that a mere low center of gravity has little to do with the truly good performance that practice supports. Having extended a due measure of attention to questions of clearance, it remained to distribute the mass as it is represented by the power plant, so compacting it as to avoid top-heaviness; in other words, the machinery equipment, as nearly as possible, forms a sheet in close proximity to the center of gravity, resolving the latter from the increments of a closely related mass rather than otherwise. It would be too much to expect that a motor with a high torque characteristic could be used in a chassis and have it perform with entire satisfaction without taking due account of the relating situations, and it has been the purpose of the designer in this case to harmonize these relations and obtain the best result.

### From the Point of View of the General Appearance of the Car

An examination of the title illustration will suffice to show a flush side type of body of the vestibule design with fore doors, and as a conspicuous incident of this design the great width of the doors may be looked upon as a factor. The space within the vestibule is considerably more than that of last year in this make of car, and comfort from the point of view of the occupants of the automobile has had a wide influence upon the activities of the designer. The cushions of the seats are 10 inches high, with a smart pitch to the rear and the use of long coil springs in conjunction with the best grade of curled hair has fortified the undertaking. The seven-passenger body as shown is almost severe in its straight-line effect, and a part of the satisfaction that has been obtained is due to the continuation of the line of the bonnet in the plane of the flush side paneling of the body. Having designed the front seats with a view to comfort in driving, which is apart from the consideration that influences activity in the rear seat work, it remains to state that the rear seats span 53 inches, are proportional in depth, and comfort is further assured by plenty of knee and leg room in the free space in front of the seats.

Among the body options, the six-passenger type is worthy of particular mention, this body being with straight sides without molding or decoration, and the rear seat is 44 inches wide. The extra seats in the tonneau are of the collapsible and folding type, dropping into the floor so that they are out of sight as well as out of the way when their use is not called for.

The close-coupled roadster represents a particularly smart undertaking with room for an extra "case" upon the rear end, with a back and trap-door entrance to the auxiliary storage space which is afforded by the design.

The two-passenger roadster is a strictly gunboat type of car with a large capacity gasoline tank, and a tourist's trunk so placed as to be out of the path of dust and dirt.

In fitting out these automobiles, while it has been the aim to afford to the company's clientele as much of auxiliary equipment as could be foreseen on a conservative basis, the fact remains that there has been a fair attempt to avoid the "undue" loading of the car, and the equipment decided upon in view of this consideration includes a cape top with top boots for all models, demountable quick detachable rims with extra spare carried rim, power tire inflation pump, complete electric lighting equipment, a well-contrived horn, ignition and lighting battery, supplemental to the Bosch high-tension magneto, shock absorbers, robe rails, foot rests, rear hamper for storage, trunk rack, locker for goggles and gloves, a full regular set of tools with proper means for holding them, and among other incidentals a registration plate holder.

In the schedule of the automobiles that will be turned out this year a certain amount of attention is to be given to coach bodies, and of these types of cars as listed in the preliminary announcement mention is made of a seven-passenger limousine vestibule with fore doors, fitted with glass enclosing side storm

panels for the driver's seat, and Berline type double enclosed limousine, straight front and hooded landaulet, not to mention the types of body work that will be entertained in the event of demand.

**The Columbia Line Will Include a Poppet-Valve Type of Power Plant**

In addition to the new Columbia-Knight type of power plant it remains to state that the company is building a 38-horsepower poppet-valve type of motor with T-head cylinders in which the approved mechanical features of the 1911 Columbia motors have been retained, and the design has been brought up to date in all minor respects. In this motor the cylinders are cast in pairs with a bore of 4-7/8 inches and a stroke of 5-1/2 inches, thus making the A. L. A. M. rating 38 horsepower. The new features of this motor include a pure-air pressure system for the gasoline supply, and a motor-driven tire inflation pump. The carbureter is raised, thus permitting the manifold to be so shaped that "loading" is avoided, and it might be well to say that the pure-air device which furnishes pressure to the gasoline tank is a separate equipment from the power air pump. The carbureter is located on the left side of the motor in the mid position, and the Bosch magneto rests upon a shelf just back of the front arm on the same side of the motor, and by way of an innovation the magneto is provided with a brake to be used in locking the driving shaft in a definite position during the time that the magneto is disassembled from the motor for purposes of inspection and repair, thus assuring the repairman that the timing will be undisturbed, since the magneto may be put back into precisely the same position that it previously occupied, and to release the brake is then the only remaining consideration. The oil pump is driven by a vertical shaft extending down from the camshaft and the pump is located horizontally in clear space between the oil sump and the flywheel. The timer is driven by an extension of the same vertical shaft and it is placed on the top of the crankcase well clear of the flywheel. Looking at the right-hand side of the motor shows the centrifugal water pump in the mid position driven by a shaft with a gear in the halftime train, and the power air pump is placed between the water pump and the rear arm of the motor, taking its drive by means of a gearset with one member on the pump shaft, and by means of a lever that is conveniently placed the gears are meshed when it is desired to operate the power pump. The oiling system in this motor includes a commodious sump in the lower half of the crankcase

for the supply of oil, a means for determining the oil level, and facilities for draining out the oil when it is desired to clean the system. The details of the motor are in excellent keeping with the main idea, taking into account the fact that users of automobiles will be safe in choosing a sleeve type of motor on the one hand or a poppet-valve type of motor as a substitute, either of which will fit harmoniously into the chassis and do the bidding of the owner.

**Steam vs. Gasoline**

*There seems to be an idea among the heads of some municipal fire departments that pumps driven by gasoline motors are less effective than those driven by steam. In the adoption of a gasoline automobile fire-fighting system the advantage of having the same power propel the vehicle and pump the water is obvious, and there are many examples of the successful operation of this combination.*

INTEREST is being centered in the problems that confront the fire departments of municipalities from the point of view of the substitution of automobile fire equipment for the old kind. Every progressive community fully understands that the automobile fire equipment is better in every way, but among the men who are charged with the various duties involved in the changing over there is an air of uncertainty, due to the fact that they fail to appreciate the significance of certain of the problems, and they are too prone to believe that there is some peculiar merit attached to a steam pump, for illustration, that is found wanting when a pump is driven by a gasoline motor. The probabilities are that quite a number of the activities of these men are based upon mere superstition. The delivery of water from one point to another requires power on the same basis as the delivery of coal, or, for that matter, gold from a mint. The delivery of water or other compounds is at the expense of power, but it is too much to expect that the water delivered will express a preference for a horsepower from a steam engine rather than a horsepower from a gasoline motor. It would be foolish to discuss this matter were it not for the fact that the engineers in the various fire departments are talking among themselves on this basis, and it is a little alarming that some of them labor under the impression that a gasoline motor of a given power is at a disadvantage when it is driving a water pump as compared with a steam engine of the same power when it is used to drive the same pump.

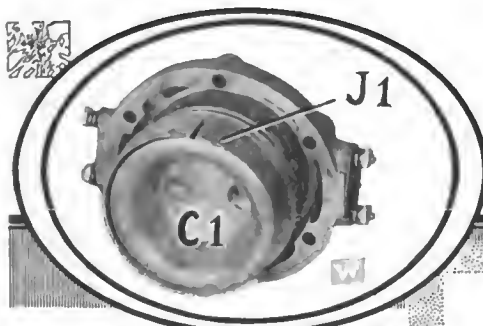

Fig. W—Looking into one of the heads of the motor.

Fig. Y—Showing the crankshaft and eccentric shaft.

Fig. Z—Looking at the head of the motor from another angle.



Fig. X—Connecting rod for the sleeves.



Fig. AA—How the connecting rod for the piston looks.

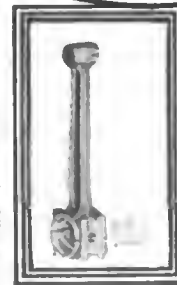

# Adulteration Bane of Good Varnish

## Thinning and Binding Materials Play an Important Part

*M. C. Hillick discusses the problem of painting and varnishing of automobiles and entertains the reader in a discussion bearing upon the subject of adulteration as it is practiced in paints and varnishes, ending up by stating the relation of the thinning and binding mediums that find a place in this class of work.*

TO the automobile owner and the automobile painter the question of purity of paint, color and varnish thinning and binding mediums, consisting principally of turpentine and raw linseed oil, is of the utmost importance. Within the past two years there has developed an increasing complaint concerning the failure of the paint and varnish structure—that is to say, the finish—to wear as all those interested have a right to expect it to wear, and within the past few months there has come an urgent demand for an explanation of the lack of durability of the automobile paint and finish.

There are, of course, many reasons, both logical and, it would seem, convincing, to be offered in justification of the lack of durability of the automobile finish, but probably the foremost reason to-day is that of sophisticated or substitute thinning and binding mediums, confined chiefly, we believe, to turpentine and raw linseed oil. At this writing raw linseed oil in barrel lots is quoted at 90 cents a gallon, and turpentine in five-barrel lots is on the market at 60 cents a gallon. These quotations are considerably lower than those prevailing a few weeks earlier in the season, but they are still sufficiently high to move the unscrupulous manufacturer or jobber to resort to adulteration as a means of easing up the market and increasing his profits.

The adulterated raw linseed oil may and often does contain anywhere from 20 to 30 per cent. petroleum in its various forms, and the substitute oils, of which we are just now hearing news in plenty, are often found to contain as high as 50 per cent. of rosin oil or petroleum. The average paint-shop proprietor, or his foreman painter, lacking a definite knowledge of chemistry, is at a disadvantage, acting alone in the matter, in any effort he may make to determine the character of the oil supply. The best he can hope to do, and the very best he can do, in fact, is to deal direct with some strictly reliable jobber, or, better still, with a crusher of established trade reputation. A sophisticated oil, or an oil substitute, containing, say, 25 per cent. petroleum, rosin oil or some other equally undesirable medium, puts the buyer in a position of paying at the rate of 90 cents a gallon for petroleum or rosin oil; and in the event of the adulteration or substitution reaching a 50 per cent. basis it is easy to understand the element of chance introduced. For determining the purity of raw linseed oil a hydrometer, an inexpensive little instrument, may be used with good results. A pure linseed oil, by the hydrometer test, should not vary 1-2 degree from 20° to 60° Fahr. Simple tests for the purity of the oil may be carried out as follows:

Mix equal parts of the oil and ammonia together. When cottonseed oil is present the ammonia drives the liquid to an opaque yellow. Fish oil under the effect of the ammonia grows white. A simple and effective test consists in taking a couple of test tubes and putting a quantity of linseed oil of known purity in one tube and a quantity of suspected oil in the other, then immersing the tubes in warm water for one-quarter of an hour, and immediately upon removal from the water pouring the pure

oil into the tube of suspected oil. Should there be existing impurities different colors will form in layers.

Turpentine, the universal and indispensable color and varnish-thinning medium, is at the mercy, apparently, of the adulterators and substitute orators. Sophisticated turpentine, or turpentine substitute is causing more trouble among a very large class of automobile users and painters than almost any other one thing.

Speaking from a practical point of view pure turpentine may be said to be indispensable. It is the paint, color and varnish-thinning medium *par excellence*. To get at the purity and, therefore, the real value of turpentine the hydrometer may very well be impressed into service. Strictly speaking, a turpentine of the greatest use in the finish of the automobile should not register above 31.1-2°, or below 30.1-2°. As a matter of fact, —or, perhaps, we should say, as a matter of business—the automobile painter, and, back of him, the automobile owner, should insist upon 31° turpentine. Sophistication of the turpentine is widespread—countrywide, we should say—and it consists chiefly of mineral oil, which medium, at its best, retards the drying of the pigment and renders its action more or less uncertain.

In turpentine substitutes there are many which contain only perhaps a small percentage of non-volatile lubricating oil which is said to come over in the fractional distillation process used in the manufacture of this material from the crude petroleum. But this minute quantity of lubricating oil is in itself sufficient to render any paint or varnish containing it uncertain in its action and devoid of its maximum durability.

A turpentine substitute composed mainly of a product obtained from the steam distillation of pine strips and logs, commonly known as "wood spirits," and, if pure, will yield very good results, as a rule. Chemists, we believe, claim that wood spirits has greater solvent power than pure turpentine, but it is deficient in those properties which have made turpentine famous the world over.

There is another class of turpentine substitutes, or materials with which pure turpentine is sophisticated, that it is worth while to here briefly consider. These solvents are obtained from coal tar and include xylol, naphtha, tolnol, benzol, and thinners of a similar nature. Practically all of these mediums possess unusually active solvent properties, and while the much lower price at which they are sold is an inducement to certain branches of the trade the inferiority of the mediums for use in the automobile finish is so pronounced that their chief use is confined to the manufacture of varnish removers and for other purposes wherein the durability and working properties and appearance of pigments is not a matter at issue.

A class of turpentine substitutes, or a class of turpentine adulterating mediums, which have attracted large attention, and which are likewise considerably used both as turpentine substitutes and turpentine extenders, to speak in charitable phrase, are derived from crude petroleum by the process of fractional distillation.

In the matter of flash point and solvent properties crude petroleum derivatives approximate very closely—almost precisely, we might say—to the pure turpentine. To subdue the flash point and hold it down the manufacturers arrange to have a certain quantity of heavier oils distilled over, which latter mediums bring the marketable product into close relationship to the naphtha and ordinary kerosene group of oils, and render them unfit, even when employed in comparatively minute quantities, for use in fine automobile paints, colors or varnishes.



A—Building a broken-stone road through swamp in Oxford County

B—Crescent Road, Rosedale, Ontario—A beauty spot of the Province

C—On the Queenston and Grimsby stone road in Lincoln County

## Ontario, Model of Road Building

### Province Has Solved Problem of Highways

*Most populous of the Canadian states has 50,000 miles of maintained roads outside the incorporated cities and has spent upward of \$40,000,000 to make and keep them. The Provincial Government has contributed over half of the sum mentioned. In parts of the section the clumsy system of working out road rates is in vogue, but the majority of the counties have adopted the most modern system of road building and maintenance. Toronto, magnificently paved itself, is one of the few large cities on this side of the Atlantic that has ever contributed a penny to road work outside its own limits.*

**T**ORONTO, July 3.—There are approximately 9000 automobiles in active service within the Old and the New Provinces of Ontario, Canada. For the accommodation of these motor-cars, 50,000 miles of public country highways—exclusive of all city roads—are maintained, of which 40,000 miles gridiron the Old Province and 10,000 miles thread the New Province. All of the work of repairing and maintaining the established thoroughfares and building new ones, is carried on under the direct supervision of Mr. W. A. McLean, C. E., Provincial Engineer of Highways to the Ontario Highway Improvement Bureau. These country roads penetrate through 500 Townships and 37 Counties in Old Ontario; and 8 Counties in New Ontario.

There are portions of the Townships in Old Ontario which still adhere to the feudal basic principle of keeping up the rural roads, the system literally corresponding with that in vogue in certain sections of the States, whereby the farmers "work out their poll-tax," by contributing each their respective share of manual labor. Nineteen Counties out of the 37 have adopted the new County system of road-building. This means that the highways of the nineteen Counties are improved and maintained under the regulation Provincial method. This system embraces three provisions which the road-builders in Counties are compelled to abide by. Each highway must be built either of gravel or macadam; steam-rollers must be used in the process of construction; and the highways must be thoroughly and symmetrically graded.

The system in its entirety, as it is found to-day, was adopted in 1901. A summary of expenditures in the Townships of the 45 Counties in the two Provinces shows that cash to the amount of \$19,015,343 was paid by the Government for the up-build and maintenance of roads from 1889 to 1908; to which must be added about \$750,000 per year during 1909 and 1910. There is now being built an automobile trunk-line road 300 miles long, from Sudbury to Sault St. Marie, and skirting the north shore of Lake Huron, the expense of which falls upon the shoulders of the Provinces of Ontario, the Counties contributing absolutely nothing.

This highway will constitute the finest automobile route in the Dominion of Canada. Independent of this highway, sixteen Counties have put up one-third to the Provincial Government's two-thirds, in an outlay of nearly \$4,000,000 for the purpose of building roads. The result is that the highways of these Counties are the best in the Western portion of the Old Province of Ontario. One essential feature of the system of road-building in question is that the Provincial Government will not extend aid to individual Townships. Co-operation must be complete. Every Township in a County must come in as an integral part, or the whole County must stay out.

A single exception to this rule is found in the instance of York County, of which Toronto, with its sublimely paved streets, is the metropolis. Toronto took a hand in building outside of its own municipal limits. This is the only city in the Dominion of Canada that has ever extended financial aid for the purpose of constructing automobile roads not within its own confines. But in this case the city contributed \$100,000; the Provincial Government gave \$100,000; and the Southern, or lower, half of York County put in \$100,000, making a total of \$300,000. The Northern, or upper half of the County declined to affiliate, on the ground that its own roads—built out of gravel, and some of which are worse than others—were quite good enough for automobiles to travel over, without plunging into the Treasury.

The \$100,000 given by Toronto is absolutely independent of the appropriations made for augmenting and maintaining her own city roads. These comprise within the municipal limits 407.57 miles of streets and 115 miles of lanes. There are 262.13 miles of





D—A fine stretch of road in Oxford County

E—Chestnut Park Road, Ontario—A stunning driveway

F—A normal road in old Ontario Province—good automobilism is promised

the streets which are paved and 145.44 miles are unpaved. The kinds and miles of pavements and roadways follow:

Asphalt .....	118.44	miles
Cedar blocks .....	17.71	"
Brick .....	25.41	"
Macadam .....	45.91	"
Wood and concrete.....	0.49	"
Stone and scoria block.....	2.34	"
Gravel .....	21.35	"
Bitulithic .....	20.68	"
Tar macadam .....	3.88	"
Concrete .....	1.98	"
Asphalt block .....	4.14	"
Unpaved .....	145.44	"

The streets designated as being unpaved include quite a number which have been improved by macadam pavement.

The system of paving with asphalt was introduced in Toronto twenty years ago, and every yard of this pavement is laid on a concrete foundation of from four to six inches with a one-inch binder course. The specifications demand a two-inch surface of asphalt.

Such a thing as a paving company securing a contract through political intrigue or graft in the Dominion of Canada is absolutely impossible. Not only have Toronto, Ottawa, Hamilton and Winnipeg asphalt paving and repair-plants of their own, but in the event of a new street being paved, or an old one repaired, the respective municipalities advertise for tenders and the contract goes to the lowest bidder, independent of the city's plant, in case the outside bidder's figures are below those proposed by the city's own engineers.

Ottawa, Hamilton, Kingston, London, St. Thomas and St. Catherine all make use of asphalt for the paving of streets; but the smaller the town, the less asphalt is used, to the advantage of brick and macadam.

The comparison between the maximum, minimum and average prices for paving with asphalt, as shown in a table from 1901 to 1909, follows:

	Maximum.	Minimum.	Average.
1901—Heavy .....	\$2.70	\$2.30	\$2.54 6/10
" —Light .....	2.23	1.88	2.04 1/2
1909—Heavy .....	1.95	1.59	1.72 2/3
" —Medium .....	1.80	1.40	1.60
" —Light .....	1.44	1.12	1.28

The extremely low prices shown during the year of 1909 were brought about rather by the keen competition existing among the contractors than by a reduction in the actual cost of pavement. However, the prices for 1910 do not vary materially from those of 1909; while the city officials anticipate about the same prices for 1911 as those which have prevailed during the last two years.

Automobiles within the Old and the New Provinces of Ontario regard the conditions as they relate to country and city in general, as being satisfactory, so far as the laws are concerned. Proprietors of automobiles pay a registration fee of \$4 yearly. Chauffeurs pay a fee of \$1 each. They are not required to under-

go a technical examination. But the majority of those who drive for owners of private motor-cars have visited the States extensively and are up-to-date. They have neither union nor club. Their wage is about \$60 per month.

The Ontario speed-limit in rural districts is 15 miles; while 10 miles obtains within the confines of cities. Search-lights are prohibited. Gasoline sells for 20 to 25 cents per gallon in small quantities and about 15 cents in bulk.

The customs duty on assembled automobiles brought into the Province is 35 per cent. When parts are imported into the Province, or the machine comes in disassembled, the duty is 15 per cent. The duty on rubber tires is 35 per cent.

The great majority of the motor-cars now in use in Ontario are American-made. Great Britain comes second; with a scattering of machines of Continental European make, and a very small percentage of cars built in Canada. In fact, there are but three of the latter—all of which contain American or European-made engines. The Canadian-built cars sell for \$2,600 to \$5,500. Motor-cars of other makes are sold at the standard prices—exclusive of duty—which obtain in the States and Continental Europe.

The Toronto city officials have adopted motor-cars for official use, generally speaking. The Municipal Government appropriated \$7,800 for the purchase of a combination hose-wagon and chemical engine for use in the Fire Department and tenders have been advertised for.

The Street-Cleaning Department has two automobile flushers and two trolley-car flushers in commission, all of which have proven to be a great success after two years of tests. They were made in England. The two automobile flushers do the work of 16 horses. They cover about 21 miles of streets in a nine-hour day, which represents the work of four watering-carts. It costs approximately 78 1-2 cents per mile with the automobile flushers, as compared with \$2 with the horse-drawn carts. Each motor-truck costs the city \$5,200, delivered.

The interests of automobilists are looked after by the Ontario Motor League, whose headquarters is in Toronto. It has a membership of 2,600, and it is affiliated with the Royal Automobile Club of Great Britain, thus affording its members touring in Europe the privileges of that Club. The Ontario Motor League grew out of the Toronto Automobile Club, which was established about ten years ago. The League stands for the protection of its members against adverse legislation; the general betterment of their interests; and the encouragement of careful driving on the part of chauffeurs.

Of taxicabs there are less than fifty in Toronto. The tariff per passenger amounts to 28 cents per mile. The vehicles were made in England.

# How the S. A. E. Worked at Dayton

## Discussion of Papers and Committee Reports

*In the issues of THE AUTOMOBILE of June 15 and 22 there were published the papers and committee reports submitted for consideration at the Summer Meeting of the Society of Automobile Engineers at Dayton, June 15-17. All the papers and reports were discussed at length by the members assembled, and many additional points of interest were brought out. A portion of this discussion was printed in a previous issue; the remainder, slightly abridged, is given herewith.*

WHEN the issue of June 22 went to press the stenographer who recorded the proceedings of the Summer Meeting of the Society of Automobile Engineers, at Dayton, had not transcribed all his notes. As much thereof as was finished, however, was hurried East, and appeared in connection with the story of the meeting. The remainder, with the irrelevancies eliminated, follows, beginning with the discussion on the report of the Broaches Division:

**PRESIDENT:** The next matter before us is the question of broaches.

**MR. DAVIS:** The canvass was made primarily to reduce the number of broaches used and to bring before the society, as you all know, the question of what really was the desirable standard to adopt, and to consider the whole matter from the manufacturing as well as from the engineering standpoint.

In our recommendations, first, we come to the spline shaft, and in that form the committee considered the matter from two standpoints. When I was here the other day in the preliminary meeting they asked me to have sketched out something that would give a little idea. (Puts sketch on blackboard.) This shows the two methods of fitting: One here—the hole ground to fit the mill portion of the shaft. This one here with the shaft ground to fit the broach portion. That is a matter that is not new in discussion, and I think the consensus of opinion of the committee was to recommend this form (pointing to same) as lending itself readily to manufacturing conditions. Our position in the matter being this that if, in machining, care is taken in regard to the broaches produced, if they are ground accurately and the sides ground, and that a hole can be broached sufficiently accurate to use it as a working point from which all finished portions on the gear shall be taken, and that the clearance can very readily be controlled because of this grinding upon the side. On the other hand, with the mill portion here it brings in the question of grinding the hole practically to the pitch line. There is quite a variety of opinion among manufacturers in regard to the loss in manufacture due to distortion from hardening or other causes, and due to imperfections in grinding to the pitch line.

As far as I have been able to discover in talking to engineers, the percentage lies in favor of using the finished broach hole as a working point, with necessary hardening to maintain size and then grinding the outer diameter of the shaft for proper clearance. That takes care of the question of the broached shaft.

Following that we come to the question of sizes, and to bring this matter before the society we sketched up this form. (Puts the form, with pins, on the blackboard.) In talking with a number of manufacturers—those who were not only using square shafts on gears for all purposes—the committee recommend, as a general standard, using the ratio between the short diameter, which is the distance across the flat and the long diameter or the diameter of the stock from which the square is made. Took that ratio as .8, and the full lines here will show you just about the proportions. This is drawn ten to one, and it shows you the relative portion of the form that is left. These sizes, in running from sizes up to inch and half, by quarter inch; and to three inch; and by half-inch sizes above that. And there it is, a sliding fit under extremely heavy duty; then carry out to dotted line, making the ratio .73. These are shown in the dotted lines, which brings it to quite a sharp point.

The committee felt that for the average practice that the .8 ratio will give good results both for sliding fits and for force fits, whatever difference there is between sliding fit and the other being made on shape. This narrows it down to one set of broaches for both purposes. It also narrows down the sizes taken within this ratio. We found by a canvass which Mr. Clarkson made that there were in use to-day something like 75 to 100 different sizes, varying by 1/64 or 1/32, and this narrows the number down to fourteen, and gives us a range which we think will give us practical results. Of course, it doesn't shut any one out from using special broaches if they see fit. But in general practice, for future designs, we believe that the range can be covered, and covered effectively, both from a manufacturing and a theoretical engineering standpoint by the adoption of these standards. There are a few errors in the table shown on page 5, and I am submitting a typewritten list here, showing those corrections which were made in the report as it comes before you later.

There is one other point that comes in the spline shaft, and that is the question of using even or odd numbers. From the manufacturing standpoint we feel that the best results were obtained, due to calibration and other purposes, by the use of even numbers. The odd number of splines is a difficult proposition to adjust and to measure accurately. As far as I know, in discussing the proposition the main argument in favor of the odd number is that it goes in the direction of the three-point suspension, possibly giving a little more accuracy. But in proper methods of manufacture it would seem to us that there would be no difficulty in using the even number, and that the advantages in favor of the even number would offset any advantage that there might be in connection with the adoption of an odd number.

There is another question in regard to the relative value of the square as against the spline shaft. The tendency at the present time is, we believe, toward the spline shaft. Of course, there is, as we all know, a combination of forces tending to open up the square that there is not with the properly made spline shaft, and there are conditions of manufacture in regard to the stock to be used where different sizes of square are to be used, which render themselves more readily to the use of splines. Personally, my preference would be in favor of the spline shaft.

**MR. VON ROTTWILDER:** When we talked about the subject yesterday, in standardizing these broaches, it should be found out how many splines we really want. One man wants an even number; the next man wants an odd number, and there we run in so many different sizes of broaches again. I think we should come to a decision as to how many splines we should use.

**MR. DAVIS:** Mr. Davis has had quite an experience in that line. I think the feeling of the committee was that on light cars four splines would be ample, and that we would hold to even numbers; but that on heavy powers, up to say over 40 horsepower and above that, that the six would be preferable as giving a little more satisfactory result. That is, it would give a greater factor of safety. But, as Mr. Souther has said, that is a matter of engineering judgment and in design in the various cars, our idea being that if the broach manufacturer is prepared to furnish either the four or six to standard size, then the matter of exact determination of that for any one designer would hardly be up to the committee, but that the society would adopt either the even or odd number as standard and the gradation of sizes as recommended by the committee, and then it would be up to the engineer of the various cars to determine whether he would use the four or six or the different size squares.

The idea was that it would be an advantage both to the broach manufacturer and to the manufacturer of parts to know that he could go and secure from stock, and the broach manufacturer also that he could manufacture in larger quantities, that in tallying up on various jobs to reduce the number to the smallest possible list, and at the same time have it effective, so that each one would be in a position to carry the work forward at practically the same cost in manufacture.

**MR. SWEET:** I would like to offer a thought in connection with locating on the outside of the driving lever. If we should adopt that, that makes it unsafe from the result that comes from a fire. It is practically impossible to fire that portion in solid. Whereas, if we locate on the hole, it will make it possible to grind the holes. In other words, they will be able to grind on both essential surfaces—the holes and the shaft portion. It would seem to me that that would be the better way because it would not make it objectionable to the manufacturer. We practice that in locating the bottom of the space. It would seem to me that there is advantage in not locating on the end of the dividing lever, but on the shaft on the hole.

**MR. DAVIS:** In covering that point it is true that there are manufacturers at present time that bring both the shaft and the bottom of the gears and the gear from the pitch line. Our main point in connection with that is in the one case, locating by the outside shaft, while it is true that we cannot grind at that point, if you choose that as a working point for all operations, it does seem to us that the percentage of loss or percentage of variation would be as small as you would get from working from any other point. Looking at it from a nicety of manufacture, it is undoubtedly true that you cannot grind both points, and possibly in some instances get a little closer result. On the other hand—I think we all have the same experience, that in gears particularly they get out of shape; they look for an eccentric shape gear, and in grinding by pivot line you are not assured of covering that point. There is a process used by some manufacturers—take it in carbonized work—of carbonizing and then broaching the finished broach after the carbonizing before the final treatment. But that has its disadvantages. I had a report from one company who had tried out both processes, using the same materials in heat treating, and it worked out that they had from two to three per cent. less loss in their gears from working from the outside diameter of the shaft over the grinding from the pitch line, and it was primarily to bring out that discussion and find out what the experience of the engineer had been, and let them, if they will, instruct the committee as to what standard shall be adopted.

**MR. FERGUSON:** We have tried both. We are at present using the outside diameter of the spline shaft and not grinding out the hole. We have adopted that and it gives some nice results. We thought we would try to alternate it and made some the other way, but the manufacturing end of our business claimed that it was too difficult a proposition for them to set up the gear by the pitch line and grind a true hole, and we couldn't find a great deal of difference in the results of the sets of gears that we made in each way, and the manufacturing end of the business decided that it was a good deal more expensive to grind the hole in the gear, and so we fell back on the old system in leaving the hole as it was and grinding the outside of the shaft.

**MR. SWEET:** Regarding the locating on the pitch line, we have had some experience along that line. About twelve years ago I spent three weeks at the Pope Manufacturing Company. Mr. Rice attempted to grind the box and holes of large bevel gears by locating on the pitch line, and the results were not very satisfactory. But when they began to locate at the bottom of the space, then the result is much better. We find that it is better to locate at the bottom of the space and then we don't enter into the straightening of the teeth. We go right to the bottom of the space, and the general result is much better.

**MR. VINCENT:** A thought occurs to me along that line: wouldn't it be possible to adopt a standard set of broaches that would be,—that would make it possible to use either practice,—in other words, the broaches to be large enough to give clearance where the hole is ground out and simply make the outside of the spline enough smaller for clearance, or where the manufacturer preferred to make the spline enough larger to grind. It is just a thought that might be worthy of discussion.

**MR. DAVIS:** I believe it would be possible to establish what has been recommended on the subject of broaches. Following the line of the suggestion of Mr. Vincent, I think it would be possible to adopt the standard as suggested by the committee and that that could be finished either way,

and it would be a question of results on shaft fittings, while your brochures would remain constant.

MR. SWEET: It would seem to me wise to leave that point open. It would seem too bad to close the door upon the other scheme. I believe it will serve more of us if we had suggestions along both lines. In other words, don't close the door. For I think many of us will resort to what we need anyway, but we would like to follow the standard as well as possible.

MR. FOLJAMRE: I move the report of the committee be adopted. Seconded. Carried.

### Discussing Magneto Standards

PRESIDENT: We have from two members in different parts of the room a suggestion that one of our committees get busy on the magneto standard; the base height of dowels and coupling distances from the gear; center from the drive and spark device will have to be considered. It seems to me this is a very good idea, and I believe we have men among our Standards Committee who can handle this matter. If not, the council will see to it that it is taken care of,—unless there is some objection. Of course, I know that there are some standards now, and it only remains to investigate them and put them in our book where they can be seen. I think no further action is necessary.

MR. SLADE: I would like to suggest while on question of standardization that some elements which will be elements of motor speed, whereby the spark advance can be eliminated will be a point that the committee can take up. There are not any magnetos on the market now which are applicable to motors having a very wide range of speed, without an automatic spark advance. I think that is one phase of the subject that the committee should consider.

MR. MUSKOVITS: The point is a very sore point with practically every manufacturer of magnetos;—the matter of couplings and base height is a very serious matter. I think that the suggestion that came from the other side of the house came from a magneto manufacturer that has over seven thousand models. And I know another one that has just about as many, and their troubles are very great. I think that there is nothing in the line of standards that would help much more than this one point.

MR. VON ROTTWELER: I think that the height of the magneto base is the most serious thing of all. Every magneto takes a different size. A man couldn't make any pattern where the arm would be interchangeable. If I have a four by four and a half motor that I sell in thousand lots, and a man says I want an arm handle on it, and that pattern is made with a fair amount of side play; and on the next order a man will want something different and I have to change my pattern.

MR. MUSKOVITS: The point that is most important is the distance from the drive outward. We have always got the German height. We all had to follow them. But it is the other distances. I think Mr. Whitman could make some remarks on that that would be interesting. He has got about 150 models.

### Discussion on Sheet Metals Division

MR. SKEMP: It is absolutely impossible to recommend the adoption of any particular class of steel for any particular part of an automobile. About all we felt we could do was to put before the users of the sheet metal the various grades that were ordinarily produced, describing as briefly as possible the finishes that were usually supplied and indicating the results that might be expected from the use of those finishes.

We are confronted, of course, by the fact that each branch of the sheet metal industry uses its own particular gauge. Some use the United States Standard gauge, and others the Birmingham Wire Gauge. We don't think it was within our jurisdiction to recommend the adoption of any special gauge. Each of these gauges has its equivalents in thousandths of an inch, and we feel if specifications were written up in thousandths of an inch, and if the specifications when so written are made to conform as closely as possible to one of the gauges of the department or branch to which the specifications refer, it will be much more easy, of course, to obtain stock sizes.

I would like to say, in regard to the finish of sheet steel, that there is a mistaken impression in the minds of most users as to the results they secure by the use of pickled and higher cold rolled material. I would say that sometimes it is necessary for that material to be used. But whenever any process involves the heating of the material before it is pressed or formed, the necessity for the pickling and cold rolling is done away with and the expense of that treatment is absolutely useless expense.

The cheapest grade,—the blue annealed sheets,—as far as the steel is concerned is the best. The finishing processes really add nothing to the value of the steel. They really detract from the steel and wherever it is possible to use the cheaper product,—the blue annealed product,—without injuring the dies or stamps, that product will give the best results.

In regard to the question of uniformity of thickness: That is a matter that has been dealt with with great care. It is an absolute impossibility in the manufacture of hot and cold material to preserve a uniform thickness throughout the sheets. There is a constant changing in the contour of the rolls owing to expansions by heat,—from slight inequalities in the temperature of the steel. And it is necessary to allow for liberal tolerance in regard to these matters. Your committee has indicated what may be considered as reasonable variations in the thickness of hot rolled material.

PRESIDENT: I feel that this report is one that might well go into our data book as it stands. It is not done, and it will be a long time until it is done. But it is a start in the right direction and is extremely instructive and ought to be helpful to anyone contemplating the using of sheet metal or the ordering of it.

MR. HUSSEY: I make a motion that it be adopted. Seconded. Carried.

### The Springs Division Report Discussion

MR. BERGMANN: You all have copies of the report of the Springs Division, and you will notice on the last page that there is some discussion regarding the size recommended on center bolts, as well as the standard thread which we suggest as  $\frac{1}{8}$ -inch pipe, requested by the committee.

MR. HOLSMAN: I was looking over this paper this morning;—I may have gotten hold of the wrong paper, but as I remember I saw the A. L. A. M. Standard thread was specified for bolts. I don't just see where that is now. I would like to ask why A. L. A. M. Standard threads should be used for bolts and springs?

PRESIDENT: There was one suggestion made to the Standards Committee and adopted by the Standards Committee in relation to flexibility.

MR. LANDAU: On the subject of springs, I would like to make a few remarks relative to nomenclature, especially "flexibility." The word "flexibility" is used by the sub-committee and its correctness applies to the semi-elliptic type of springs. The word "flexibility" is used abroad to-day as denoting the deflecting per 100 kilograms. But they also use the same word in a little different form. They place fifty pounds upon the quarter section and call the deflection the flexibility of the quarter portion.

The advantage of stating flexibility in that method is very evident to one trying to calculate it, because by adding the flexibility of half elliptic per 100 pounds to the flexibility of quarter elliptic per 50 pounds, you get the total flexibility of the three-quarter spring. I would suggest that the term flexibility be as stated in the report and add the flexibility of the quarter for the deflection of fifty pounds on the quarter portion.

In reference to nomenclature, there seems to be some inconsistencies in the definitions. First we have A, known as half elliptic. Under B, it says, "elliptic; consists of: top half, elliptic; bottom half, elliptic." It is evident from that that Spring B must be composed of two full elliptic springs. In other words, it is twice as many springs as is shown there.

In reference to C, called the scroll elliptic, I am inclined to believe if this was placed in our data books there might be some misconception because there is a type of spring that is used,—particularly abroad,—and will be in this country, known as the scroll, which is practically the same as that shown, except that the shackle of the scroll portions has the scroll portions independent.

In reference to F, the definition of the three-quarter elliptic, there are some inconsistencies at the bottom there where it says joined at both ends by bolts. From the sketch it is evident there are not two bolts. Therefore I would like to see the word "bolts" changed to "bolt."

In regard to G, we have a form of spring down which is very largely used to-day in horse-drawn vehicles. But upon investigation—when I received this report—I might as well say that Mr. W. H. Son, who is on this committee, asked me to take care of some of this for him, and he gave me at my disposal quite a lot of information, regarding quite a lot of the springs that they have been supplying. There is only one manufacturer who supplied the type G for the automobile in the last seven years; if there are any more, I would like to know it, and I have never seen it used on an automobile except once. I would, therefore, suggest that type G is practically obsolete as far as the automobile is concerned, and I don't see that we need a definition here.

On the subject of springs shown in type H, known as the three-point suspension. It has long been known as a form of platform spring. It would be better to call it a three-quarter platform, because the term "platform" has been very common. Therefore, I suggest that we adopt the name of three-quarter platform for the so-called three-point suspension.

About that four-point suspension, I must state I have never seen it used in an automobile.

In connection with the recommendations on page 5 for ordering springs, there are several places I wish to call attention to. I might stop here for a moment and digress from the subject by saying that I think it would be advisable for the committee to add to this paper sketches indicating the dimensions to be followed in ordering, because I find that the men who are working in the spring plants cannot name certain parts without you show a sketch indicating what you mean on account of the variety of sketches.

Under A we have, "Give type of springs desired. Exercise great care to select types suited for purposes to which put." I would like to have the committee recommend the type for suitable purposes. In other words, how can we exercise care unless we know what type we are going to use. It seems that the committee should exercise care in recommending a type.

In B it says, "Specify material." There is no objection to that as long as the material is specified in a proper sort of way.

In C there is some misprint. It says, "Specify width of spring either by 000 or  $\frac{1}{4}$  inch." I think the committee intends that to mean, specify width of spring leaves in inches. Or if it intends that to mean thickness, it should be inches or the standard gauge. Otherwise, C is inconsistent with itself.

The next subject which is really of importance, and is not quite so academic as some of the others I have mentioned, is the question of standard sizes and width of steel. The committee recommends inch and a quarter for pleasure cars. I don't know, but I would like to ask Mr. Tuthill if he considers inch and a quarter a standard size for a pleasure car. Inch and a quarter and inch and a half are not really standard size for pleasure cars. They are special sizes. I venture the opinion, and I rather think I am right, that our mill don't carry those in stock as regular sizes for an automobile. The three-inch size recommended in the same place is not really used in pleasure cars. It may be put down as commercial pleasure car size,—such as the large sight-seeing wagons.

In D,—"Number of leaves in gauge to be left to the spring maker." I don't know what that means,—unless the word "in" should be changed to "and."

Referring to E, it says, "Give offset, stating length on both ends on straight line between holes in brackets. This should be given on all half elliptics." I prefer there myself to show a sketch, because we don't know what the half length of a spring is; sometimes it is not a half length; that is, in the offset spring there are two halves, which are equal to a whole, but not halves in themselves.

In the three-quarter scroll, bottom half, the committee says, "Give distance on straight line from hole of front bracket rear spring to point on frame vertical to rear axle." I would like to know if the axle is going to be parallel to the floor. That seems to be inconsistent. I would recommend that the committee in this particular case shall be requested to make a diagrammatic sketch, indicating clearly what they mean. I venture to state if this paragraph is read carefully, almost every member in the room will give a different opinion.

Getting down to the latter part of it on the same page it says, "Give distance from spring seat to spring seat, or bracket holding upper quarter." That is not really what the committee means, I believe, and a sketch here would be very advisable. In the case of a three-quarter scroll the distance is usually given from the bottom,—the short space of the half elliptic. That is not stated by this definition. At least it wouldn't be considered so by a spring maker.

I would like to ask the committee what they mean,—"Do not give depth of scroll."

Commenting on some of the things that are mentioned here that are excellent,—for instance, "Give clearance under load with passengers, in front of two nearest striking points and position relative to rear axle."—I do believe, in taking the entire report of the committee,—this one paragraph is really the most important, taken every which way. We have complaints in regard to springs, from this feature. It is not the spring makers' fault. It is the fault of the customer in not giving the clearance in front of the two nearest striking points. I imagine it has cost every spring maker a good many thousands of dollars a year to get this little information. If it is not stated, you are likely to have the spring maker make a very heavy spring, or he is likely to get it too light. But he can make them right, and make them cheaper, if you give him the right information in the first instance.

Next, we have, "Give center of load front relative to front axle" and "Give center of load rear relative to rear axle." Those two points there I want to say that I don't personally understand what they mean. I would like the committee to make it more definite.

It says, "State whether spring takes driving." I would suggest that they add "before breaking." Because the stress of the main leaf changes very rapidly. If it does take breaking, the number of clips applied to



the spring will vary if the breaking in must be taken on the spring. "Give number of passengers," I think is very advisable. There is one point that was discussed at the recent meeting of the Society here,—that is the truck situation. Everybody is interested in truck spring design. It says here, "On trucks give merchandise load." I would simply add at present that it is desirable for several reasons,—the truck designer would especially appreciate it, if you were going to supply cars to a certain concern and you know any of the service,—I would say give the merchandise load and also the nature of that load. If you are going to supply one hundred trucks, we could give you better springs if you can give the nature of that load. It doesn't cost any more to you to specify it, and you will get a better spring for less money. If you have got to carry flour, you will have to have a little different spring than to carry beer.

On the subject of flexibility, I have expressed myself already. Next we come to the features to be left to the spring maker. It says, "Eye up or down, in or out." When I first returned to this country after having served my apprenticeship with spring makers abroad, and I came home and found expressed in and out. And frequently what was meant by "in" was "out." I would suggest that here is a very important point for the committee to indicate by sketch what they mean by eyes up and down, and in and out. While it is perfectly clear to the spring maker, it is not to the spring user. There are conditions where the designer will know much better which to use. Of course, he can leave it to the spring maker in certain cases, but there are cases in which he cannot leave it to him.

I don't know what the committee means by "spacing of leaves." But I suppose it is the pitch of leaves. In which case, it is commonly expressed in technical literature, as the pitch of the leaves, rather than the spacing of leaves. The committee has to "state whether shackles are under compression or tension and length of shackle used." I don't know whether it is essential to know whether the shackles are under compression or tension.

I am not prepared to express myself on the subject of bushings. I will say that with gas-hardened holts, bronze is desirable, although the question of steel hushing,—I don't know.

In connection with eyes on pleasure car springs; for reasons that I cannot express briefly, I am sorry to state that I cannot agree with the committee on this subject at all. It is impossible to specify these on theoretical grounds and on practical grounds we have got to wrap two leaves around the eye, and the eye we have here is simply the common eye, and you will find that they have three springs wrapped round the eye. And there are good reasons for it. That is, the clearance upon the successive wrappings of leaves, which are even more important; many of the engineers say that the eye wrapped around the faces have no clearance. With one engineer he wouldn't allow us to separately open the eye a quarter of an inch to allow for the location, and it would be advisable for the committee to add a certain opening that must be kept, so the engineer will not insist on the spring maker giving him what is a close wrapper, which is a physical impossibility, because it doesn't work that way unless you introduce severe stress on the second holt. I would, therefore, suggest that the idea of one leaf he left entirely out, or left to the spring maker.

In regard to the width of bar, the committee states that there are zero tolerance and plus tolerance. Zero tolerance means the size of the bole and the size of the holt are absolutely the same.

### Discussion on Uniform Gear Shift Position

**PRESIDENT:** The next matter is the report of the chairman of the Miscellaneous Committee.

**Mr. BERGMANN:** We have several questions to take up. The first is the gear shift position. The matter of the gear shift has been referred to the members of the committee, and we have submitted sketches with the three- and four-speed arrangement. Naturally this is an interesting subject and I would like to hear from the members in regard to their choice.

**PRESIDENT:** It is considered possible by the Standards Committee to put in our data book several gear shift gates. This may do something toward keeping the engineers or draftsmen from designing new ones. I don't know that there are any more new ones, but possibly there are. There is no doubt that all cannot concentrate on one, but if they could concentrate on two or three, it is certainly something, and so this subject is before you from this point of view.

**Mr. RICKER:** I would like to repeat some of Mr. Camper's points that he brought up; they are, as shown here, that the high speed should always be at the back, and that it was advisable with this combination to have the emergency brake a pull lever. In that way, a man in a hurry to stop would not have the opportunity of grabbing hold of his speed lever instead of the brake, because the high speed lever would probably be at high speed, and the brake lever would be entirely isolated at the forefront of the quadrant.

The other point that he brought out was that with a four-speed gear box you invariably start on second speed, so that you really have the same conditions with four-speed gear box that you have with three-speed gear box.

**Mr. MYERS:** I would like to call attention to the fact that there are two, of course, two styles of gear box using four gears; one in which the speeds are progressive, and the other in which the high gear is a gear up from the direct drive. In connection with that, the fact that on the last mentioned type of box, it is sometimes quite important to have the first gear and the reverse directly opposite one another, so that they can be readily used in traffic. The fourth gear is not as a rule used in traffic or in the city, but when you get out on a clear road it is, and I think that sketch should be included; and the fourth should be shown, there being three slides on the outside. I had a little experience with a gear box of that kind and where the reverse is put, as it is here, on the inside, it would be much more convenient to have No. 1 and the reverse in the same side; probably the fourth outside.

**Mr. MOSKOVIC:** It would seem to those, who, like myself, want to go and borrow one of their friend's cars, that it is an embarrassment to find the low and high speed levers on different sides. It would seem that the committee could recommend a position of the low and high speed. It would make some advance in that line, and it would assist some of us that use so many different cars.

**Mr. RICKER:** In connection with putting the high speed on the outside, one point was brought up, and that is with inside levers on a fore-door gear it is most convenient to have the high gear as close to the outside as possible so as not to interfere with the comfort of the driver.

**Mr. COFFIN:** It is just as easy for the designer to adopt one form of lay-out as to adopt a diversified lay-out, a different lay-out, because in nearly all sliding gear boxes, there are nearly always two or three slides used whether the high or low speed levers are put on the inside or the outside, according to the designer's selection. The idea in laying them out as they are laid out is that the form of the high and low are all the same in the three and four gear boxes. Almost invariably a four-speed

box is stated on second gear, which on the four-speed box is exactly the same position as is first speed on the three-speed box. Therefore, the movements that the driver goes through in any of these designs are exactly the same. Had that been covered? The position of the high-speed lever at the rear places it in an out-of-the-way position at any time or almost invariably at the time that the emergency brake lever is to be reached in a hurry. In other words, there is no possibility, even for an amateur driver, of becoming confused and getting hold of the speed lever instead of the brake, and that happens very frequently. He will grab the gear shift lever and pull it back into some other speed and then get completely rattled; whereas if they only had one lever in front of them and that a brake lever there would be very much less chance to get into trouble.

### Standardizing Steel Flywheels

**Mr. BERGMANN:** Another subject that was referred to the Miscellaneous Division was that of screw standard. (Mr. Bergmann here read the proposed changes.)

**PRESIDENT:** That matter has been very carefully discussed by the Standards Committee and they believe that it should be acted upon at once. They further brought up the question of changing the name to the S. A. E. standard.

**Mr. COFFIN:** There will be no objection, I believe, to the standards becoming known as S. A. E. Standards. The A. L. A. M., had turned over to this society all the work connected with such matters as this, and the name even of the organization once known as the A. L. A. M. has been dropped, and it would seem to me to be highly desirable to make these standards known as S. A. E. Standards. This would prevent any confusion which might arise in connection with any future work along this line that we might want to do. I think that is all, from the committee's standpoint.

**Mr. FOLJAMBE:** I move that the suggestion of the committee that these standards be called S. A. E. Standards be adopted. Seconded. Carried.

**Mr. C. E. DAVIS:** In connection with that, does that cover the necessary publicity in connection with people who are designating these in their catalogs?

**PRESIDENT:** The question now is as to the adoption of the modification and extension of sizes. A motion is in order. The A. L. A. M. dimensions are now in the data books. The changes are very slight, and they are not in the body of the thread, so that there will be no serious complication. It is a matter of head size, and it amounts to nothing from the engineers' standpoint.

**Mr. BIRDSALL:** I move the alterations and extensions be adopted. Seconded. Carried.

### Discussion on Tolerance of Spark Plugs

**Mr. BERGMANN:** The next question is the tolerance of spark plugs. The consensus of opinion seems to be from plus zero to minus .003. Is there any discussion on that?

**Mr. FERGUSON:** I think I suggested that. I had a lot of trouble with different size spark plugs that they were making. And we wanted a pretty good fit, so I suggested .003 for the minus; and nothing over for the spark plug size. I don't think that is too small a tolerance to allow; .003 over size hole in the cylinder and .003 in the plug is .006, and it don't work well.

**PRESIDENT:** Is it the wish of the members that this refinement be adopted and the tolerance be plus zero, minus .003?

**Mr. BIRDSALL:** I move that be adopted. Seconded. Carried.

**Mr. BERGMANN:** The next question is the standards of the rod and yolk ends as submitted by Billings & Spencer. This work has been gone over very thoroughly by the committee and has been accepted unanimously.

**Mr. BIRDSALL:** I would like to make a motion that on any of the former A. L. A. M. standards, when they are refined by this Society, that the name is changed to S. A. E. standards. Seconded. Carried.

**PRESIDENT:** The question is now on the adoption of the rod ends, that is, the recommendation of the rod ends and the subsequent printing in our data books.

**Mr. H. I. POPE:** I would like to make a motion that the rod ends be accepted and put in the note book in accordance with the recommendation of the committee. Seconded. Carried.

**Mr. BERGMANN:** The committee wishes to announce that the title used in page 188 in the Transactions and known as Specification No. 26 for Oils, to change the name from Automobile Lubricating Oil, to Automobile Engine Lubricating Oil. I would like to have the members express their opinions on the vehicle taxation basis. The committee has asked me to announce that.

**PRESIDENT:** The question of automobile taxation came up last summer, and a number of us, to my personal knowledge, have been trying to find a formula that would fit all road users—horses as well as motors. The question of the old formula suggested itself— $MV^2$ . And in attempting to apply that, it was found that  $V^2$  was too big an element; that the figures went up out of sight. Then  $MV$  was tried, and  $MV$  seemed to fit pretty well, and then some attempt was made to find for what reason we should use the  $V$ , and quite a bit of correspondence was had with the railroads as to whether tracks wore out in proportion to speed or in proportion to load. It was stated by Mr. Buckwalter that it certainly was not speed and surely not the square of the speed;—that it was somewhere between  $V$  and  $V^2$ —probably near the  $V$ . The Michigan Central, I think it was, stated it was probably near the  $V$ . So I wish some of the members would set their wits to working to try and find a formula that we may safely hand to our law makers. Our law makers are coming to us pretty soon, and ask us how to tax all users of roads. With these thoughts in mind, the matter is open for discussion. Are there any thoughts?

**Mr. HAYNES:** I think a certain amount of experimental data would have to be obtained first. The formulas would be of no value unless backed up by data that had been demonstrated by actual experiment, before it could be endorsed by the Society and before it would be a proper subject for consideration.

### Standardization Steel Flywheels

**Mr. BERGMANN:** Can I hear from the members regarding their views in connection with steel flywheels.

**PRESIDENT:** A very interesting matter has been broached by one of the large steel companies. They now say they are making some steel flywheels and welcome and ask our co-operation and ask that we give them sufficient data so that by some means they may propose a standard or get up a standard lot of steel flywheels which are forged. They get right down to nearly cast-iron price with their very rapid method of forging, which amounts to nothing short of spinning. They spin up the steel just as you spin up pottery.

**Mr. FERGUSON:** We have used for two years now a forged steel fly-

wheel on our largest size engine. It has quite a large diameter. We are afraid of cast iron, and we have got a forged steel wheel there. And it works just as well, if not better. It gives about the same coefficient as on the cast iron. In fact, it makes a much better wheel. The thing is in perfect balance. There are no porous places in the forged wheel. It is a balanced wheel and requires very little attention.

Mr. HOANING: It has recently been our pleasure to go into the matter of steel flywheels with the steel company, rather than that they went into the question with us. And the first statement was that the cost of the wheel would be approximately what cast iron would be. We consented to have them make a standard wheel; it seemed that they had their specifications and standards at their place of manufacture. They submitted these, and we found that the cost of the wheel to us rough was more than the finished flywheel in cast iron. Now, I assume in submitting the figures that they gave us a wheel which they were producing in large quantities. And I had several calls from the representative, and he at last had to give up the job and admit that the steel flywheel in the rough would cost as much as the finished flywheel in cast iron.

It is only a question of safety in flywheels that we have found in our experience that the user looks at in flywheels. Where flywheels are cast with blades for producing the draught, the strings which fit on the relief are a constant source of danger. We have one experience with one flywheel which was being used at the time by a manufacturer to test out the engine. He was making a test on it, and it broke. An examination of the break showed that it was a casting string. In connection with the heat produced by the break and the heat due to centrifugal force, it was too much for the string and it separated. I recently heard of another case of a very well known car that it did the same thing. Therefore our experience with vane flywheels, as we call it, unless particular pains are paid to the relief casting strings, is that there is a great source of danger, there, but in the flywheel with the usual construction of solid web you can use a section down to 3-8 of an inch with safety.

Mr. VINCENT: There are so many engineers right here assembled that are undoubtedly building motors, and if this one company wants to adopt a standard flywheel, and a certain motor has a compression of 65 or 70 pounds,—the next man has that same motor of the same bore and stroke with a different compression entirely. Now, in order to have a higher compression you need more flywheel energy and I think too many different sizes of flywheels would be needed to meet the demand, and I think a standard in that is out of the question because there are many different sizes of motors and so many different compressions in those motors that I think there would be so many different flywheels needed that it would be impossible to come down to a standard in flywheel design.

Mr. COFFIN: I don't believe that it is possible to carry the idea of standards into a matter like a flywheel, which is so intimately interwoven with the vital parts of the construction. You have the gear box behind and the motor in front,—if you standardize the flywheel, I don't believe there will be very much limit to what you might not do. I think the things we should attempt to make standard are the things that might just as well be standard as otherwise. We have tried to avoid the standardization of any part which, or upon which the designer may legitimately exercise a reasonable ingenuity or ability. Such matters as rod ends and carburetor connections and so forth,—upon such matters as that, I don't believe there is any engineer in the room who would care to spend very long in instructing some draftsman how they should be made. Therefore they may be incorporated in tables and that detail removed from our attention, to let us concentrate on things that are more important.

### Paper on Aluminum Castings

PRESIDENT: One member is here who has come a long way to present this paper, Mr. Gillett.

Mr. GILLETT: The paper has been printed and anybody that is particularly interested I hope will read it. The proposition that I want to bring out in this is that with the increasing number of aluminum castings the factories are requested to make they run up against very great difficulties, due to design and to patent constructions. The vital point of the whole matter,—the one that concerns not only the manufacture but the price and delivery—is in getting together with the factory at the right time. If the designing engineer would take these matters up with his factory and get their ideas on it and get their pattern makers in touch with the factory, it would aid a great deal.

I have a few samples here showing some of the defects due to faulty design, which perhaps I haven't time to pass around, but anyone that is interested can see them. They are labelled with the numbers corresponding to the reference in the paper. The whole proposition,—the best design of aluminum castings—is one of uniform section as near as possible. Here are two samples. Those are parts of the same castings. This one is well designed; that is, there is no sudden great changing of section. This one you see has a crack in there. You have large sections here next to small sections. The small sections freeze first; the result is a crack. The losses on this proposition were far too much. There is no reason why they all should not have been made solid.

One other point is the design of the casting in such a manner to allow cold pouring. Cold pouring gives you fine crystals, well interlocked, and a strong nut, because the freezing takes place equally. If you have exceptionally thin portions in your casting, you have got to pour hot in order to fill your castings. The effect of hot pouring is shown by this bunch of test parts here, which corresponds to that shown on page 4, showing how the tensile strength falls off extremely rapidly with the increase in pouring temperature. This bunch of test bars shows a very good tensile strength, and at the hot end,—these were all poured from the same batch of metal,—at the hot end you get a very weak bottom,—very rough surface. If you can take up with the factory while your new designs are in your mind and in your draftsman's hands these points with those that handle the manufacturing of the material. I think you will serve your own best interest, and I think you must remember that these things we cannot change,—the design is up to the designer, and perhaps half of our factory troubles are traceable directly to the design and construction of the pattern.

### Long Addendum Gears—Oversize Piston Standards

PRESIDENT: Mr. Weaver is here with a very good paper on Long Addendum Gears. The long addendum gear seems to be of greater value on one particular place, and that is the bevel driving gears, on the rear axle. There was quite a discussion the other night in regard to noise. This seems to get away from it to a certain extent. And it also provides a much stronger form of outlay. That is the main things to be said in favor of it. It does not require any special outlays, except possibly gages for making it, most of the bevel gears being cut on Gleason machines.

There are one or two errors or corrections that might be made. On the second page down near the bottom, it says "For 20 degree pressure angle multiply the circular pitch by .5927 and .4037 respectively for the pinion

and gear." It should be .4073. And on the next page, the sixth line from the top, it isn't clear. It reads B minus C, and it should read "line BC." There isn't any minus in there at all. And down a little further, there is a rather complicated formula given. It can be simplified greatly by multiplying the circular thickness by 28.648 and dividing by the radius. It is a matter of cancellation and of course it is not printed in such a way that it would be very clear.

I have also added tables for the thickness for 4 1-2 degrees. For any one that wants to do a little experimental work it will merely furnish a little data to work from that has been valuable.

PRESIDENT: The next paper is by James N. Heald on "Oversize Standards for Pistons and Rings." This paper will not be read. What is the idea of the members present as to the possibility of doing something toward standardizing oversize pistons?

Mr. COFFIN: Throughout the manufacturing season, there are always a certain percentage of cylinders faulty, through oversize dimensions. A cylinder is a pretty expensive portion of the car construction and naturally there is considerable regret in the manufacturing department with having a scrap pile of cylinders charge to their department. Our own practice is to save up cylinders which were oversize, and at the end of the season bring forth a series of motors, using these cylinders,—properly numbered, so that the service department can keep track of them,—and regrind them to a certain definite oversize. This saves a great deal of money.

PRESIDENT: Have you any thoughts as to taking action on that matter among the committee?

Mr. COFFIN: It would seem very simple to adopt certain dimensions for oversize dimensions and for reworking of old cylinders for which it might be necessary to get larger pistons. We might go up by steps of .005 or hundredths of an inch or something of that sort.

PRESIDENT: At the bottom of page 8, in this paper it says: (Here the president read all of that part of the paper on pages 8 and 9, under the heading "What The Oversize Standards Should Be.") There is a suggestion of two oversize standards. Is it something that you would like to have the Standards Committee take up?

Mr. FOLJAMBE: I move that the Standards Committee take up this matter as suggested in this paper. Seconded. Carried.

PRESIDENT: Mr. Clayden, do you know whether or not European manufacturers have made any attempt to carry oversize pistons?

Mr. CLAYDEN: I don't know definitely that any of them are doing it at present. I know that they have in the past. It is rarely difficult to obtain an oversize piston.

### Reducing the Number of Lock Washer Sizes

PRESIDENT: It is apparent from some of the statements made during the Standards Committee meeting that the various engineers have all taken a crack at lock washer designing. Now, it is a long jump from three or four hundred sizes of washers down to sixteen. It seems like a very radical measure perhaps. You will notice the typewritten list shows only sixteen sizes of lock washers, all of square sections, and that the square section is practically the short diameter of the U. S. nut and the long diameter of the A. L. A. M. nut. So it seems it has logic hack of it. Is there anything that is objectionable in that? Is the washer too heavy, and is the proportion of  $\frac{3}{4}$  height to 1 width wise? The objection may be raised that the lock washer may be a little thick. Of course that will help its holding power, and that little is not very much. There is no question but what if sixteen sizes can be used for all purposes or up to inch and half bolts that the cost of lock washers will not increase—it may diminish after the trade becomes adjusted. There has been raised in committee the alternative for the 3/16 bolt, instead of 5/16 use 5/64; for one quarter, instead of 5/64 use 3/32. That is an increase of a sixty-fourth only in a few cases. Those small things seem to be the only question raised in committee.

Mr. HINKLEY: It seems to me that the suggestion about the smaller sizes is good. For instance, 3/16 or quarter-inch sizes are heavier than we will be able to use in certain places. It seems to me that the thickness is running out of keeping with the width. You take any parts designed where the property of appearance enters into it very strongly, it seems to me that we could get a slightly thinner washer that will serve the purpose better, due to the fact that a thinner washer will give a better locking property.

Mr. SAYMOUR: In regard to that matter, one of the trunk lines in the country was using a washer  $\frac{3}{8}$  wide. They decided the washers did not have enough spring pressure. They did not want to spend more money for their washers and raised the question whether another shape wouldn't give the result. The shape of their washers was  $\frac{3}{8} \times \frac{1}{4}$ ; in other words, the cross section which should be the same in a washer 5/16 in. square. They had some sections made which were 5/16 square. And they subjected the washers they had been using and the new type to a pressure test. They found the  $\frac{3}{8} \times \frac{1}{4}$  gave a pressure of some 1800 pounds and the 5/16 gave a pressure of 2800 pounds; they have been making the square washers since 1885, and this washer in service will give just as good results as a washer whose height is one-half its width. In this list the outside diameter of the washer corresponds with the long diameter of the A. L. A. M. nut and practically corresponds to the short diameter of the U. S. standard nut. In other words, it comes as near a perfect appearance as you could get. The square gives the proper results as to resiliency. These sizes have all been used or ones the same form, so that we can stand behind each section and guarantee its efficiency. The same difference in shape has been made to accommodate the A. L. A. M. and the U. S. nuts.

Mr. HART: I think that the Lock Washer Committee have cut the engineers down to too small variations. The engineers have designed over three hundred variations. I think I must give the automobile engineers credit for knowing the thickness of washers that they want in connection with their cars. Now, I appreciate the advantage of cutting down this list to sixteen if we possibly can. Take the 5/16 washer. I do not believe it can be used in all parts of the car. I do not believe that you can use it on brass or aluminum as well as you can cast iron. The locking power would be too great on the aluminum and brass; if that part had been taken off you would only destroy the lower backing, where the 5/16  $\times \frac{1}{4}$  could be used, very successfully with cast iron or steel. I therefore would favor giving the automobile engineers a greater variety to allow them a greater selection, so that they can choose a washer to fit the bolt, according as the washer is going to come in contact with either brass, aluminum or steel.

It seems that on 7/16 washer Mr. Seymour has remarked that there is only a slight variation of thickness from what the present automobile manufacturers are using to-day. I would like to say that for the past two years the automobile people have come together and have agreed to use and are using each others' washers more than they were four years ago. I can name thirty-five concerns to-day that practically adopted the 3/16  $\times \frac{1}{16}$ ,  $\frac{3}{8} \times \frac{3}{32}$ . I don't think it is necessary that we should hold to the square section,  $\frac{3}{8} \times \frac{3}{8}$ , 7/16. I would recommend 11/64  $\times \frac{3}{8}$ ,  $\frac{1}{2}$ .—11/64  $\times \frac{3}{8}$ , 9/16. I think a most satisfactory washer could be used there by using 7/32. Take the 11/16,  $\frac{3}{4}$  and  $\frac{1}{2}$ . It really seems to me that, although very few of those three sizes are used to-day in connection with

the pleasure car, we hope that they will use more of them in connection with trucks. It seems to me that the Lock Washer Committee should give the automobile engineers, say, three variations of size on 1/16 washer and three variations on the quarter-inch; three variations on 5/16 and 3/8, keeping, of course, the standard lock washers as small as possible. You take the 5/16 washer; if they should prove of use, 3/8 x 3/32; this washer is almost too heavy to put in connection with any part where there is any brass. There is a great deal of manufacture, and it seems that on the last four sizes beginning with quarter-inch to 3/8, they have given such slight choice. Taking into consideration the lock washer manufacturers are carrying such tremendous variations of steel that it seems that these four sizes should be brought in, and the majority of automobile makers are using them to-day. That would be 5/32 x 1/4 washer. I would like to change that size on half inch—make that 11/64; change 5/16 to 11/32 x 3/8.

I think all the lock washer manufacturers to-day are practically manufacturing every size that the other has done. And it has been very difficult to get one engineer to change over. For instance, if you tried to get him to use 8/32, which you were furnishing to fifteen others, he absolutely refused to do it. They had designed a certain washer, and they considered it best for the place they were going to use it. There are many of them using two or three sizes on the 5/16, claiming that they have to on account of the metal they are using. I don't see but what the engineers would like to get all the locking power they can. They would like to use 5/16 washer, if they believed it would give greater locking power, than this 3/8 x 1/16, but the metal backing will not allow them to use it.

Mr. SEYMOUR: That point against aluminum and against brass raises a point that has been argued by a good many of the automobile engineers, but I will state here that the largest users of lock washers use a 5/16 washer and use it against aluminum with no protection between the lock washer and the aluminum. Now, if you are going to look at securing good locking power against aluminum you have got to have a washer which is strong enough to take a bite on the nut. If you put a very thin steel washer between the nut lock and the aluminum it will not take as good a hold as the thicker washer, and the thick washer will not break off the aluminum. Now, the manufacturer to whom I referred is to-day using sections from a quarter and up larger in each case than the sections recommended by this committee. They have been using them for three years and the use has been very satisfactory. There was a good deal of question raised about three years ago regarding the use of thin washers. We tried them out ourselves and tried them out in comparison with other washers, and our experience was that they did not hold. We wanted to have an unprejudiced opinion on the matter, so we wrote to R. W. Hunt and Company in Chicago, asking them to make a test on washers. They used washers 3/8 x 1/16 and 3/16 square in their tests. They tested them on nuts and counter pins. I have a result of the test here before me. In the case of the washer 3/8 wide by 1/16 in height, they secured looseness after an average number of revolutions of 60,675; with the square washer it took 87,800; and in the installed nut and counter pin that created between fifty and eighty thousand vibrations, and the result showed that the effect upon the square washer was practically zero.

Mr. HART: The practice of using a steel washer in connection with lock washers is quite old; but on this Lock Washer Committee we are trying to get away from sizes; you are introducing and asking the automobile manufacturer to use the proper weight washer that will dig into the head of the screw. I don't agree with Mr. Seymour that a washer made from 1/8 x 1/16 steel would not mar the head. I don't believe that all the engineers can get along with these washers. Mr. Seymour speaks of one concern using the size he recommends; the sizes I recommend are being used to-day by more than fifteen concerns and the largest machine makers of this country.

Mr. BIRDSALL: I agree with Mr. Hart that we need two thicknesses, although I recognize fully Mr. Seymour's remarks on the subject. It is my experience that the square washer is too strong on an aluminum backing. The only question is whether we can get a lighter washer that will bite into and also not ruin the aluminum backing after it is taken down three or four times in the repair shop. And I think there is enough of us here who have had experience with lock washers, so that we can determine now and incorporate in our suggestion to the committee the thickness of the lighter washer. My opinion is that they should be either two-thirds or three-fourths of the thickness of the square washer.

Mr. VONROTTWEILER: Now, here is a washer on this table, 5/32 inch thick; for instance, on 5/8 bolt,—if I wanted to use it against aluminum, I wouldn't care to use that; there would be too much pressure against the aluminum; that would be too much because you would tear the aluminum right out. You just dig a hole right in the aluminum, just by taking it off once.

Mr. TRASK: We use a great many quarter twenty screws in a certain part of our car, under which we want a light washer, that is, about right for a thickness of not more than perhaps 5/32 of the thread; that is, threaded aluminum. Now, under those conditions it seems to me that 5/64 square is altogether too severe on threads of that length. Consequently, I think we ought certainly to have a lighter washer, perhaps two-thirds the width of the stock.

Mr. BIRDSALL: In getting at that 2/3 I think we had better hear from the gentlemen who dress the steel and see whether there is any commercial difficulties in the way of dividing these fractions by three; and whether it is possible to adapt the thickness to the practice of the steel makers.

Mr. BUGIE: It only means new dies. The three-fourth dimension would be much better because those sections are already in use. And of course the washer manufacturers have steel on hand for those sections, but they have no steel on hand for a section contemplating two-thirds.

Mr. SEYMOUR: In the typewritten recommendations nothing is said about parallel face lock washer, and as there seems to be some confusion between the terms "plane" and "parallel" as used by the different manufacturers, I would recommend that the following paragraph be inserted: "That washers shall be of perfectly parallel faces and that bulging or mal-formed ends shall be avoided." The motion was seconded. Carried.

### Concerning the Report of the Carbureter Division

Mr. VINCENT: Mr. Sweet suggests that we stop off at 2 inches and not try to standardize the (carbureter) flanges above two inches because those don't interest very many of us. If we get into 2 1/2 and 3-inch size, we have got to go into the four bolt construction, and there seems to be a good deal of difference of opinion in regard to the proper arrangement in the four bolt construction.

There was considerable discussion about the exact form of gasoline and water unions and the form of the throttle connection. The Standards Committee didn't exactly like the report of the committee on this arm, as they thought it was not quite definite enough, and it seems to be a general feeling that it would be impossible to standardize the throttle arm further than possibly the size of hole and the thickness of the boss at the end of this arm, which should be 1/4 inch for size of hole and 9/32 thickness of boss, to correspond with A. L. A. M.

In going over a great many different carbureters some variation in size

of pin was found. One manufacturer might have it 1/4 inch. Another manufacturer will go 1/32 over that, or 1/32 under it. So that these flanges have been laid out sufficiently large to give reasonable gasket width, even on the largest opening, and of course the gasket will be a little larger on the smaller opening, but we have tried to strike a happy medium and not change anybody's flange very much. You will note that all the well-known carbureters follow this design closely. There were just enough differences to keep it from being interchangeable. The first thing to take up and see what we can settle on would be the matter of flanges. Is it the consensus of opinion that it would be well to stop off at two inches for the present and not try to standardize anything over two inches?

Mr. SWEET: The report is not quite complete, and we thought that we had better cover the sizes up to two inches, and then we can add information—after we can agree better on that point—above two inches. Mr. Vincent has said that the attempt has been made to change the standard flanges as little as possible. Having something to refer to until we get better information, we can refer to the Society's standards for two inches, and we will all know what we are talking about.

Mr. BRIGGS: It would be impossible for us to change at present to the sizes given there. We have written to several carbureter manufacturers, and they have all agreed to make them one standard. There are three or four manufacturers that have agreed to make it to standards such as we now use, and we wouldn't like to have this thing settled without a little further getting together of the manufacturers. We are all trying to standardize with the standards we now have. They make a very serious difference as regards the water jackets, and it would mean absolutely upsetting the entire factory, and also would make a considerable change with a number of customers who have their manifolds drilled to our standards.

PRESIDENT: Various attempts have been made to get the carbureter manufacturers interested in this problem. The response has not been very quick. Consequently the committee places before you something that seems right. The other aspect of the situation is this: that there will be no immediate revolution, but the changes made will be made in connection with new designs. That is, assuming that an engine is to be designed next month,—instead of taking something that exists or something new, as might be done, the engineer or draftsman will go to this little data book and take what would be known as a standard flange. Now, if that standard is a bad one, that is what we want to bring out at this time.

Mr. BRIGGS: Suppose the manufacturers of carbureters should all agree on a standard—would that suit the Society—if we would get together?

PRESIDENT: I would say if the gaskets were wide enough and of a suitable shape and pretty much like these, why, something might happen.

Mr. BRIGGS: The difference would be very slight,—it would be a thirty-second here or there; nothing radical. Nothing different in the design or in the general appearance of the flanges here.

PRESIDENT: The situation is this: If the carbureter people had come forward, they would have had a hand in it and the whole matter would have been adjusted at this time. Now, to get action, the committee places something before you. If it is bad, say so. If it is good, adopt it.

Mr. BRIGGS: The only statement that I had to make was that the difference is very slight, and I thought we ought to see the manufacturers before deciding on this and see whether they would rather use the standard that now exists among two or three of the manufacturers or wanted to have them changed over to the proposed standard. It wouldn't take much time.

PRESIDENT: We are confronted by exactly the same thing that happened in the tire matter. All have got to yield something. The differences of various carbureters have been in the hands of the committee for some time and were in the hands of the committee when these sizes shown on our blue print were adopted. Now, Mr. Behn tried to justify the differences and make the difficulties just as small as they could be; that is, not to punish any one company by radical changes, and that is what the blue print is supposed to represent.

Mr. SWEET: Each manufacturer wants to influence the standard towards that he is himself using. And if we leave it to the manufacturer we won't have uniformity. And the best results will be obtained in general if you follow out some uniform system that the committee has suggested.

PRESIDENT: In other words, you feel that these flanges are a fair solution of the problem?

Mr. SWEET: Yes. We find the carbureters wanting to cover an extra 1/16, and they rub the flange surface, and the flange is so light that the work will have to be very nicely done or the carbureter will leak. I believe that these standards are reasonable.

Mr. VINCENT: I would like to explain that it is the committee's idea that these flanges should be put into the note book as soon as possible, and that it wouldn't affect current models, but when we design a new engine, we could then use the standards. For instance, if we were designing a new engine and wanted to use a freak flange, the chances are we could get the manufacturers to make the flanges for us; and why not lay out carbureter flanges along the same lines, instead of making new designs? If we could get carbureters with the same size flange, that is going to simplify the proposition, and as you run out of current models, the carbureter manufacturer will drift into the standard flange. So it don't look to me like it will place a hardship upon him.

Mr. POPE: I would like to make a motion that the report of the Carbureter Division of the Standards Committee be adopted as far as the sizes of flanges is concerned up to two inches. Seconded. Carried.

Mr. VINCENT: The next point is the matter of gasoline and water connections.

PRESIDENT: That was very carefully discussed by the Standards Committee and the point brought out as to the length of the connection. Its advantages,—removing vibration, supporting the pipe, making repair easy. A motion would be in order to accept the report as far as these connections are concerned.

Mr. BIRDSALL: I move the report be accepted, in that particular. Seconded.

PRESIDENT: It is moved and seconded that the report be accepted as far as the gasoline and water connections.

Mr. AULL: As I remember, at the Standards Committee meeting the other day, the suggestion was made that you standardize the pipe connections. It is not indicated here. It should indicate the size of pipe that can be used on a certain number carbureter. There ought to be something done.

Mr. VINCENT: Personally, I would like to have seen the connections standardized for each size carbureter, but as there seems to be so much variance in the size of pipe used, it seems almost impossible to standardize the pipe connections at the present time. I must admit that I don't know just how to go at that,—to get down to a standard on it. Of course, it would be possible to tap out all carbureters large enough to take the largest pipe,—but whether or not that would be a good idea, I can't say.

Mr. SWEET: The fear along that line is on account of the various systems. One using the pressure system can get along with one kind of pipe, and one using another system wants a different size pipe. It would seem unwise to establish that for all. This report, as was suggested, is



quite incomplete. Whether we have accomplished enough to adopt certain portions of it is for you to decide. It was our opinion to submit the report as far as it had gone and add to it later.

**PRESIDENT:** Is there any danger in using this standard connection up to two inches?

**MR. SWEET:** I think not. I think it is very good up to the two-inch size. The reason we wanted to omit these larger sizes was we didn't feel just sure about them. We have been impressed with the fact that this supporting portion must be of quite definite size because if that is carelessly done and made 1/32 over size, it is entirely worthless. It has got to support the pipe very closely, and the difference there is to be recommended later. If you see fit to pass upon this, it is incomplete, and we feel that we could improve it very much before another meeting.

**PRESIDENT:** If the manufacturer takes hold of what we now have, we will be no worse off than we now are, because I will assume that he will make a reasonable fit. He tries to do it now, and he will try to do it with this standard before him, and that is a matter that can be refined. It is in the nature of a refinement rather than a radical change.

**MR. VINCENT:** The only other point is on the matter of throttle arm, and it is the opinion of your committee that it is almost impossible to standardize this throttle arm further than possibly indicating the size of the hole and the thickness of the boss. We believe that, after considering the matter in the light of the Standards Committee's suggestions that the hole should be 1/4 inch, instead of 1/64 larger than the diameter of the pin or bolt, and that the thickness of the boss, 9/32, is O. K. That will conform to what has been the standard A. L. A. M. rod. I believe that all members of our committee would be glad to see the cut taken out and the dimensions given as a suggested standard for the throttle end; that is, quarter-inch hole and 9/32 thickness of boss.

**MR. POPE:** I make a motion that the eye of the lever be adopted as shown in the cut and stated by Mr. Vincent. Seconded. Carried.

**MR. AULL:** The motion was carried before the Standards Committee the other day to make the minimum length of lever two inches.

### Views of a British Expert

The following extracts from the speech of Arthur Ludlow Clayden, editor of the *Automobile Engineer*, of England, proved to be one of the most interesting of those made at the banquet of the Society of Automobile Engineers at Dayton, Saturday, June 17. Among other things he said:

"One of the most interesting things I notice here is the difference between the automobiles of England and those of this country. One hears a great deal about the difference of the conditions in this country and in the United Kingdom. After all, it is a matter of road surface and variation of climate and temperature. It only means that your task is more difficult than the task we have at home. It really means that you have to guard against certain things we don't have to guard against.

"With respect to the engine, I see no reason why the small-bore long-stroke engine, which has proved in England undoubtedly superior to the older type, should not be found useful to you. I believe it is possible to make a long-stroke engine that is lighter. It runs at higher speed and you get less trouble in your transmission. And I should think that where roads are bad that would be even more advantageous than where roads are good.

"There are of course a great many engines in England in which the stroke-bore ratio is 1.5. There are a number of engines with stroke-bore ratios of 2. It is a little bit difficult to express a definite opinion. I am inclined to think that 2 is carrying it a little too far. But I think 1.75 will become quite common.

"Of course, the speed of these small engines is very high, too. I recall one that had a bore of 80 and a stroke of 120, and the number of revolutions was 3850 per minute. It is a little bit hard to believe. But in that case the valves were special and their diameter was considerably more than half the diameter of the cylinder.

"The great difficulty with these engines has been lubrication. Splash lubrication is entirely out of the question with an engine running at such high speed. The controlled splash with dippers on the back ends has proved useful for the comparative high-speed engine. But it is certain that the engine where the oil is flowed with force pressure is more durable. Of course, the Lanchester engines have always been so. They are supplied with oil where it reaches the engine at 30 pounds per square inch. The same applies to a number of others, and these engines last very much better than engines with splash lubrication.

"The great trouble with these engines has been the balance. That may be overcome in two ways. One is by making the reciprocal parts much lighter and also paying attention to rotation balance of flywheel and crank shaft. The other is by adding a number of cylinders and using small six-cylinders instead of large four-cylinders. That has signs of getting to be popular. That has difficulties owing to shaft whipping. That rotation balancing machine is doubtless going to help us put it right, and bearings between each crank throw are also essential. We have found that that balancing trouble is one of the most powerful influences against ball-bearing crank shafts. The ball-bearing crank shaft gives too little rigidity. It doesn't give you a rigid support, and the crank is going to roll around on the balls to any extent it likes; and there is very good reason to believe that it does so at high speed.

"The only other thing about engines is with reference to two-cycle engines. The two-cycle engine is coming to the front very much. I think it is an open question whether the engine in the future is going to be a two-cycle valveless engine or four-cycle engine. I believe in the possibility of the rotary valve over every other kind of engine. I think the rotary valve is the most mechanical idea. I won't say that I have seen any rotary valve engine which seemed to be obviously the right thing. I think we are going to get an ultimate type which will be a very good engine. Which of them it is of course time alone will show.

"The two-cycle engine has been made in very many forms. I believe that more two-cycle engines have been built in this country for body work than in all the rest of the world. The pump-filled two-cycle has also received a good deal of attention. And the Lamper engine was one of the few which was really feasible. It gives a very good gasoline economy. The N. E. C. engine which is oiled by the splash method is another engine that has appeared feasible. Then the Illinois engine,—now there are two cylinders connected with a common composition chamber, so that the fresh gases have got to pass through the whole system before they get to the outside. That is also very successful.

"The next point which we have been spending much time over is the quieting of transmission and axles. The manufacture of a perfectly quiet gear is always likely to be a matter of very great expense. If you are going to run spiral gears, they will have to be as accurate as a ball bearing or even more accurate. They will have to be ground perfectly

and as far as I am aware there is no method for grinding small spiral gears which is anything like practical on account of the cost. Very much the same thing applies to bevel gears. Therefore I think the worm gear will come in entirely for the back axle, and I am not very sure just what the chain will not come into ordinary use for pleasure car work, as well as for truck work. There is one advantage of the chain box for truck work—we find in England that omnibus drivers and truck drivers are very careless men. They are likely to knock the transmission, but the worst thing you can do to a chain transmission is to break the chain. The cost of renewing the chain entirely—not considering the cost of a few links—is very small; and it is absolutely nothing as compared with the cost of putting in a new spiral gear which has been stripped. To insert a new spiral gear means taking the whole box to pieces. I know the London General Omnibus Company claim that they saved six thousand dollars a year on work alone.

"We have been discussing a good deal at home as to whether we are not building our frames too rigidly. You have only got to watch a car going over a rough road to see that a frame cannot remain rigid; and yet the majority of frames are made to be rigid. That produces body troubles, which I notice you are getting over here by the very extensive use of metal. I was very much interested in some of the bodies I have seen as being enormously strong. But I should think that they must be bad in places, after the bumping that they get on some of your country roads. Still more does this apply to trucks. There again I don't believe that anywhere in the world people are making proper bodies. I think the structures are too rigid. And I think the future will show us some frames or body designs with a certain amount of spring to allow the whole body to roll about on the axle freely.

"Another point on which I should like some information, and I am going to endeavor to get it before I go back, is as to why brakes in this country are almost invariably on the hubs of the rear wheels. The external brake has disadvantages; the big disadvantage is shown when it plugs up with mud, and I am sure that is the trouble that is found here. Of course, the internal brake can plug up, too, and if you run cars down to the axle, I should think they would get just as bad treatment as any external brake.

"What surprised me was the absence of transmission brake. I have always found that I could use a transmission brake under certain conditions of road surface when it wasn't safe to apply the brake to the hub. I believe the brake going through the gear has an influence upon the non-skidding properties. I know that is so upon greasy macadam. I should think that it would be so here. Of course I realize that a propeller shaft brake throws a great deal of stress upon the transmission, which it doesn't receive with the hub brake.

"The front wheel brakes I have tried myself, and I have talked to a great many other people who have tried them. Some of our manufacturers are building them as standards and some if requested. The front wheel brake has the advantage of pulling you straight. It has a great disadvantage if you apply it hard enough to lose all control over the steering. I was trying a system of brake which acted on all four wheels at once. I have tried it under extremely severe conditions of road surface, and I found it was practically impossible to create a skid with it. I also tried using the brake on one front wheel and one rear wheel, on opposite sides. That kept it from skidding, while the power was slightly less than when on all four. We are bound to see some developments of that nature.

"Another thing which interests me very much over here is the system upon which most of your works are conducted. That is, a system where you have a chief engineer with a staff acting as an advisory committee of construction.

"I believe that some of the best engineers we have got in England began their work as repairmen and gained their experience through others' failures. I know that some of the most successful designers began that way; men who were actually at the bench in a country repair shop, and there had opportunities of noticing the things that broke in cars of every variety. I believe, therefore, that every designer ought to have a stay in a repair shop. I think that a man who has been designing for some years would find that it would help him to go out and work in a garage for six months.

"I have heard a lot about the difference between the wood that is obtainable in the different parts of the world. There is no doubt but that the hickory wood that you get here will build a better wheel than any wood we have in England; but it won't build a wheel that is anywhere near as strong as a wire wheel. It won't build a wheel that is as durable as a wire wheel. It has been claimed that wire wheels are easier on tires. I have no evidence on that. I don't think it is likely to be a very big difference.

"The tire wear comparisons are extremely difficult to make because it is hard to get the same conditions twice. Even if you put one wheel on one side of the car and one on the other,—even then one tire is on one side of the road and one on the other, and it is always different, when the traffic is going in one direction. But I do believe that the wire wheel or the steel wheel is going to displace wood entirely in England.

"The only slide motor which I had some personal experience with is the Knight. I believe the Knight engine's method of getting free of the trouble of noise and of rapid opening is a very good way. There is a wonderful number of them running in England and running extremely well. The great advantage is once it is right it stays right until it is altogether wrong. There is no valve-grinding. Another thing is that it runs much better when it has got a fair layer of carbon deposited. I think it is a cool engine; when you have got a bit of a layer of carbon on the inside that retains the heat and gives you better working conditions. I think it is likely to be very many years before any one type of engine comes out on top,—even indeed if it ever does. One finds modifications of one kind or another. There must be a great deal of personal choice on the part of the designer. I don't think it can ever be otherwise."

**PROPER PLACE TO STOP**—When stopping for any cause the automobilist should bring the car over to one side of the road so that it will be out of the way of other traffic. In doing this a position should be taken up so that when the car is started again there will be no difficulty in getting under way. In bringing the car to the roadside the driver not only allows others the use of the road but protects himself from being run into or hindered while making repairs, etc. On the other hand, drivers who are otherwise considerate sometimes remain in or near the center of the road, if the stop is an involuntary one, and commence repairs, hindering other cars from passing and running the risk of being hit.

**Convenient Position for Tools**

Editor THE AUTOMOBILE:

[2,723]—I am desirous of having a body built according to my own design and would like to keep the running boards as clean as possible. I have made provision to carry the spare tire in a drawer under the rear seats, which eats up a good deal of space, the cushions being made deep, as suggested by you recently. Could you give me an idea of how to carry some tools that are likely to be wanted from time to time and do away with the unsightly tool-box that is found on the step of nearly every car? My experience of these things is that they are not waterproof, besides being unsightly, and the tools become covered with rust if left in the garage for any length of time without being used.

JOHN.

New York City.

The method shown in Fig. 1 should overcome your difficulty, as by this means the tools are kept dry and out of the way, but instantly accessible when wanted. There is another advantage, viz.: out of sight is out of mind, and there is less likelihood of some one "borrowing" anything without permission.

**Authentic Information as to Indianapolis Race Is Hard to Get**

Editor THE AUTOMOBILE:

[2,724]—In the issue of THE AUTOMOBILE, June 1, in the list of prize winners in the Indianapolis race, you gave Dawson (Marmion) fifth place, while the detailed account of the race you gave the fifth place to De Palma (Simplex). Will you kindly enlighten me in the matter through your columns?

SHEPARD WILLIAMS.

Newton Highlands, Mass.

THE AUTOMOBILE published in the issue mentioned all the information of an authentic character that could be had in relation to this matter.

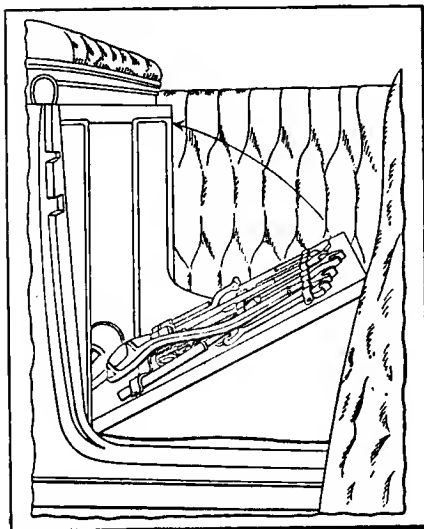

Fig. 1—Showing how the tools can be carried behind the front seats

**What Some Subscribers Want to Know**

**Open the Exhaust Valve a Little Earlier**

Editor THE AUTOMOBILE:

[2,725]—I have a four-cylinder motor with the following valve timing: Exhaust valve opens 45 degrees before lower center; exhaust valve closes 15 degrees after top center; inlet valve opens 20 degrees after top center; inlet valve closes 20 degrees after lower center. Will you be good enough to inform me if you could recommend any valve timing that would decrease the tendency for the motor to heat and at the same time not materially affect the power?

E. EVANS.

St. Louis, Mo.

Quite a number of motors are so timed that the exhaust valve opens as much as 51 degrees early. You might emulate this good example. It is more than likely that your

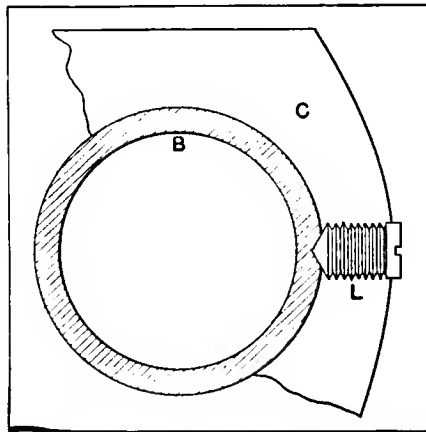

Fig. 2—Method of holding the camshaft bushings secure and preventing them from turning

heating trouble is due either to an accumulation of carbon within the motor cylinders, or a scale formation on the exterior domes thereof; and it is also possible that the ignition system is too poor to properly ignite the mixture, in which event the flame travel will be retarded and overheating will be the normal expectation. Another way to lower the heating effect is to adjust the carbureter so that it will not deliver too much gasoline. This adjustment should be made when the motor is running slow, and the air adjustment should be accomplished when the motor is running fast.

**Linseed Oil Will Prevent the Creaking Trouble**

Editor THE AUTOMOBILE:

[2,726]—If the spokes of an artillery wheel creak when the car is started or the brakes applied, and tightening the hub bolts proves ineffectual, what should be done under the circumstances? It seems to be due to the spokes drying out and the application of linseed oil has been suggested. Only the

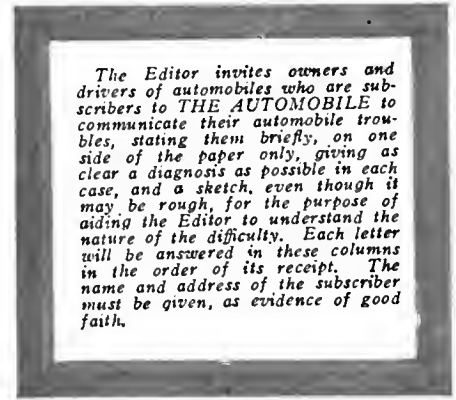

rear wheels, which are subjected to the alternate driving and braking stresses, are thus affected, but the braking strains are unusually severe, as the brakedrums are not bolted to the spokes.

MURRY FAHNESTOCK.

Allegheny, Pa.

Take the flange off the wheel and apply linseed oil with a brush, taking enough time to make sure that the oil will soak in, then put the hub flange back and fetch up tight on the holding bolts.

**How to Stop Camshaft Bushings from Turning**

Editor THE AUTOMOBILE:

[2,727]—Would you kindly tell me, through your Letters column, how I can prevent the bushing of the camshaft of my motor from turning with the shaft. The bushing is made of phosphor bronze and the crankcase of aluminum.

Philadelphia.

F. W. MARTIN.

The method shown in Fig. 2 will stop the bush from revolving; but in case the bush has increased the size of the hole it might be as well to have a new bush turned up. The crankcase C in which the bush B is housed should be drilled and tapped to take a small set screw L.

**Address the Maker, Who Will Apply the Remedy**

Editor THE AUTOMOBILE:

[2,728]—Being a constant and interested reader of THE AUTOMOBILE I take the liberty of asking you for a remedy for my Packard car. I have driven a Packard "30" for 15,000 miles and then had it overhauled in the agent's repair shop. Since then I have had trouble with the water; in driving my car over a mountain road on second speed it will boil. It never did this before it was overhauled. The circulation seems to be good and the radiator is clean.



# What Other Subscribers Have to Say

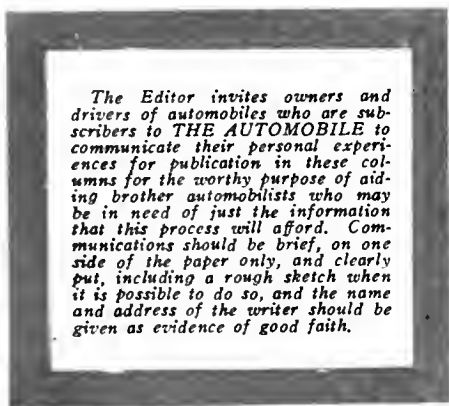

The Editor invites owners and drivers of automobiles who are subscribers to THE AUTOMOBILE to communicate their personal experiences for publication in these columns for the worthy purpose of aiding brother automobilists who may be in need of just the information that this process will afford. Communications should be brief, on one side of the paper only, and clearly put, including a rough sketch when it is possible to do so, and the name and address of the writer should be given as evidence of good faith.

It has plenty of power and runs very free. A remedy for this will be very much appreciated.  
DRIVER.  
San Francisco, Cal.

### Interest Centers in the Motor Scavenging Problem

Editor THE AUTOMOBILE:

[2,729]—As a constant reader of THE AUTOMOBILE I have become very much interested in a means you mention for a more complete scavenging of a motor in your issue of May 18 on page 1142. I take the liberty of asking you where I can receive more information or reports of tests on the subject or if you know of some motors on which this scheme is used.

A. G. ROSENRETER.

Boonton, N. J.

We have no information relating to the use of a device as referred to on page 1142 of THE AUTOMOBILE of May 18, as shown in Fig. 43. Isolated uses of a device more or less of this character would seem to indicate that it is an efficacious device.

### How to Find Critical Speed

Editor THE AUTOMOBILE:

[2,730]—I was interested in a reply to a letter that appeared recently in your paper with reference to cars overturning, and on reading some literature on the subject I came across the words "critical speed." Could you tell me how to determine the critical speed?  
J. W. T.

Shenandoah, Pa.

First find the center of gravity of the car fully loaded and let this be represented by S as seen in Fig. 3. AB represents the wheel track and the line MS perpendicular to AB. Then, as the wheel A is just about to lift off the ground there can be no pressure there, and hence if the moments are taken of all the forces about B the sum of the moments must be zero.

That is,  $F \times SM - W \times MB = 0$ .  
If  $W$  = the weight of the vehicle,  
 $V$  = the velocity in feet per second,  
 $R$  = the minimum radius of curve through which the steering wheels will turn the vehicle, in feet,  
 $g = 32.2$ ,  
 $F$  = the centrifugal force acting at S due to the turning action of the vehicle,

Then

$$F = \frac{WV^2}{gR}$$

$$\therefore \frac{WV^2}{gR} \times SM = MB$$

Canceling the common factor  $W$ , the equation becomes

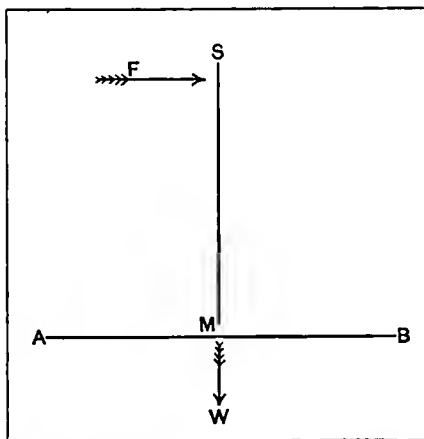

Fig. 3—Diagram used in determining critical speed

$$\frac{V^2}{gR} \times SM = MB$$

$$\therefore V^2 = gR \times \frac{MB}{SM}$$

$$V = gR \times \frac{MB}{SM}$$

### Simple Ignition Wire Attachment

Editor THE AUTOMOBILE:

[2,731]—I have been troubled with the ignition wires of my new car. They are all loose, and apart from making the motor look untidy they rest against the hot cylinders. I suppose the heat will have a bad effect on the rubber. Could you suggest a simple method of holding them together?  
TROUBLE.

Mullica Hill, N. J.

Take a piece of fiber and drill four holes in it for the wires to pass through, so that they will be a snug fit in the manner indicated in Fig. 4; then, with a bolt and nut and a piece of sheet metal, a clamp can be made to hold the bracket on to the intake manifold.

### The Left Hand Should Be Used in Cranking a Motor

Editor THE AUTOMOBILE:

[2,732]—I saw in your paper some time ago an article on cranking a motor. I do not agree with you that the right hand should be used, as there is great danger of striking the wrist should the motor backfire. There is a tendency to throw the hand into the path of the crank. The proper way is to use the left hand, then a backfire will do no harm, as the hand is thrown away from the path of the crank. I have tried both ways and only yesterday I had a backfire and carelessly used my right hand and got hurt some. I consider it very dangerous to crank with the right hand.  
W. W. TREVOR.

Lockport, N. Y.

We do not call to mind having recommended right-hand cranking, nor would we consider doing so excepting in individual cases when the left hand is out of training.

### E-M-F Gear Ratio

Editor THE AUTOMOBILE:

[2,733]—Will you kindly inform me, through your columns, what the different gear ratios are on the E-M-F "30"?

Johnstown, Pa.

W. G. M.

The ratios are as follows:

High gear— $3\frac{1}{4}$ :1.

Second gear— $6\frac{1}{4}$ :1.

Low gear—11:1.

Reverse— $6\frac{1}{4}$ :1.

### Get the Maker to Support Suitable Equipment

Editor THE AUTOMOBILE:

[2,734]—We have a four-ton Knox truck which we would like to limit to 12 to 15 miles per hour. Can you give us the name of a manufacturer of a governor which we can attach to same?

E. P. LUTZE.

Buffalo, N. Y.

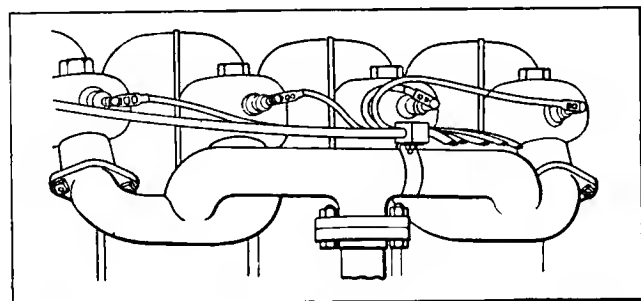

Fig. 4—How the loose ignition wires can be kept from rubbing against the cylinders



# Meeting Recurring Troubles

## Presenting a Series of the Most Probable Cases

A series of correlated short stories, accompanied by diagrams and characteristic illustrations, including the nature of the troubles that are most likely to happen to automobiles, discussing their causes and effects, all for the purpose of arriving at a remedy. It is the aim, for the most part, to show how these troubles may be permanently remedied, and as a secondary enterprise it is indicated how the automobilist can make a temporary repair, thereby enabling him to defer the making of a permanent repair until a convenient time arrives.

**SPLASH LUBRICATION OF THE KISSAL KAR**—The Kissal Kar four and six-cylinder motors are lubricated by the splash system. The oil tank is located in the base casting of the motor and forms the lower half of this casting. The oil reservoir is filled through a large filler opening in the forward left-hand side of the crankcase, which is marked in large letters: OIL. The filler opening is opened by means of a hinged cover which can be lifted and swung back.

The oil is drawn from the engine base by means of a rotary gear pump, driven off the cam shaft. The pump forces the oil into the splash troughs located in the upper base casting, on a sort of tray above the reservoir. There is a splash trough below each cylinder.

After having filled each of the splash troughs the oil is allowed to flow into a drain pipe, which runs the entire length of the crankcase. This drain tube is punctured by a long slot at each trough through which the oil enters the tube and drains back to the rear of the engine and down into the reservoir. There is a lever on the forward left-hand crankcase supporting arm, which may be raised or lowered, thereby turning the tube which contains the slots and respectively raising or lowering the point at which the oil may flow into the tube. The level of the oil in the crankcase at any time may be determined by means of a level gauge glass on the side of the motor.

As has been seen, the crankcase is sub-divided into an upper and lower half. The upper half has a trough below each connecting rod throw, into which the connecting rods dip, churning the oil therein into a flying spray or vapor.

The excess oil drains off the cylinder walls and flows back into the troughs, and in like manner drains off all the other bearings back into the same. After overflowing the oil will be drawn through the pump and used over again. Before entering the pump the oil passes through a screen in the base of the motor.

This screen and the pump itself should be often removed and cleaned. The brass inspection plugs on the left-hand side of the crankcase should also be removed from time to time, to see that the oil openings in the supply pipe from the pump to the splash troughs are not obstructed in any way, as this would allow a greater supply of oil to get into one cylinder than another.

The timing gears are oiled by the connecting rod splash by means of an oil pipe which leads from the crankcase into the timing gear case. Other bearings all over the car are lubricated by means of oil holes or grease cups, as the case may be; while the transmission and differentials are packed in oil and grease.

**LUBRICATION IN AMPLEX VALVELESS CARS**—The Amplex Model H. 30-50 horsepower car is lubricated by the force feed system.

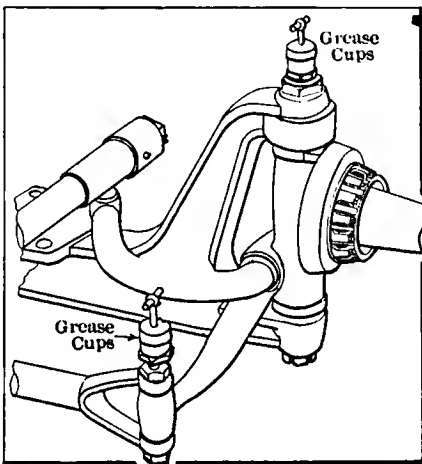

Fig. 1—Illustrating the manner of oiling steering knuckle on Amplex automobiles

cast by the force feed system. The crankcase is divided into three horizontal sections. The lowest section of the three is an oil well and this taken in conjunction with the oil in the force feed box carries the oil supply.

The force feed oiler is of the Hancock type. It is driven by gears from the crankshaft. The oiler is located on the exhaust side of the motor and takes up about half the length of the engine. It is boxlike in form and rests on a broad flange which projects from both sides of the crankcase for the entire length of the motor. The reservoir is cast integral with the crankcase.

Near the front end of the mechanical oiler box the filler hole is located. A spring cover can be lifted up on a hinge when filling the oiler, exposing the opening which contains a gauze screen through which the oil is poured.

A pump sends the oil from the reservoir through a sight feed on the dash, back to the mechanical oiler, then through a separate lead to each cylinder and main bearing as well as to the timing gears. There is one lead to each of the four cylinders, to the five main bearings, and to the timing gears.

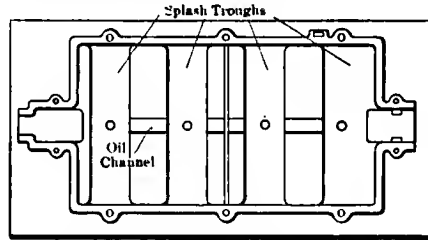

Fig. 2—Looking down into the oil reservoir as it is used on Kissal Kars

The flow through each of the leads may be made to be a certain proportion of the total flow, which is governed entirely by the speed of the engine, since the oiler is driven off the crankshaft. The relative speed of the whole oiler to the revolutions per minute of the engine is determined by the gears, but the amount of oil delivered depends on the stroke of the oil pump. This can be governed directly from the dash by means of a lever. This lever projects from the top of the oil box at about the center and is drilled at the top to allow a rod to be attached so that it may be operated from the dash.

Each oil lead has a sight feed on the top of the oiler box. A main sight feed located on the dash shows whether the whole system is working properly or not.

The oil drains into the bottom of the oil pan in the lowest part of the crankcase and will gather there in a quantity if too much oil is supplied to the main bearings and cylinders. In a case like this blue smoke will issue from the exhaust pipe and the lever on the dash may be used to diminish the supply of oil given to the motor.

There are drain pipes located in the bottom of the crankcase through which the oil may be allowed to flow out.

There are compression grease cups on the water pump bearings, steering knuckle bearings and oil over the car at the revolving or oscillating bearings. The transmission and differentials run in oil while the universal joints are packed in grease.

**FORCE-FEED OILER USED ON STODDARD-DAYTONS**—The Stoddard-Dayton model 11-K four-cylinder car is lubricated by the force-feed system. The crankcase forms the oil supply tank and carries about two and one-half gallons.

A gear-driven oil pump which is actuated by the camshaft takes the oil from the base and pumps it into a manifold which serves as a distributor. The leads are supplied from this distributor and run directly to the crankshaft and camshaft bearings.

After lubricating the various bearings, the oil drains back into the bottom of the crankcase, which is covered with a baffle plate to prevent the oil from splashing into the cylinder in case the connecting rods should dip into it. The force-

feed system is designed to completely and sufficiently lubricate the whole engine. On the rear right-hand crankcase supporting arm there is an oil level gauge glass. The oil in the reservoir should never be allowed to fall so low that it is not visible in the level glass.

When starting on a trip the oil level in the crankcase should be examined and if a sufficient height is not indicated on the level gauge, the reservoir should be filled. This is done by means of a filler pipe located between the two central cylinders.

The amount of oil supplied can be governed by means of a regulating nut on the side of the crankcase. To increase the supply of oil sent to the distributor the lock nut should be loosened and the regulating nut screwed down a turn or two, the lock nut is then tightened up again. To decrease the supply the process is naturally directly opposite to that of increasing it.

On the dashboard there is a pressure gauge which indicates the pressure on the pump. This

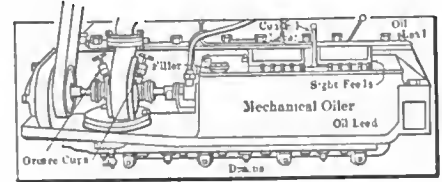

Fig. 3—The mechanical oiler of the Amplex and indication of oil distribution

pressure for ordinary country work should be about two pounds. For city use, however, the pressure need not be as high as this.

As the oil by this system is used over and over again it is evident that an adequate straining system must be employed, so a strainer is placed so that the oil passes through it before entering the pump and another which strains the oil before it returns to the reservoir.

**OILING APPARATUS IN USE FOR COLBY CARS**—The Colby "40" is lubricated by both the splash and force feed systems. The lower half of the crankcase is divided by means of a horizontal partition into two parts; the lower part forming the oil reservoir and supply tank for the motor. The horizontal partition or tray is shaped so as to have a depression forming a small well beneath each cylinder. These wells are the splash troughs.

The oil in the splash troughs is constantly added to by that which escapes from the force feed system through the crankshaft bearings. As the oil is supplied to the splash troughs faster than it is used, there will always be an overflow over the walls of these troughs. This overflow finds its way back into the oil reservoir by means of overflow holes.

The force feed system is entirely separate from the splash system just described except that the oil for the splash is replenished by the oil flowing off the bearings supplied by the force feed system. The latter is operated by a gear pump driven off the camshaft by worm gears. It is located within the crankcase, which has a recess in both of its halves to accommodate the pump, pump shaft and gear. The pump may be removed from the pump chamber through an opening in the bottom of the crankcase.

The pump and gearing are located at the rear end of the crankcase on the left-hand (exhaust) side of the motor. This pump delivers oil to the main bearings under a pressure of about four pounds. After lubricating these bearings the oil is carried by centrifugal force through ducts in the crankshaft, into the connecting rod bearings. Then the oil will be thrown off the cranks and connecting rods into the cylinder or work its way up to the wrist pin.

The excess oil drains back to the oil troughs, which are constantly kept overflowing; the overflow draining back to the pump recess, where it passes through a strainer. The capacity of the oil reservoir is two and one-half gallons.

The transmission is packed in non-fluid oil as are also the differentials and the universal joint between the clutch and transmission. The other bearings are equipped with grease cups.

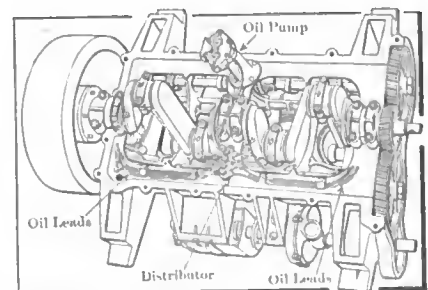

Fig. 4—Looking into the crankcase of the Stoddard-Dayton from below, showing oil leads

**LUBRICATION OF THE MOON "30"**—The Moon car is lubricated by the splash system. The oil supply is carried in the crankcase, which is so divided as to provide an oil reservoir in the bottom, as well as to carry a set of splash troughs. The splash troughs are carried on a horizontal partition which is cast directly in the base of the crankcase, being an integral part of the same.

The capacity of the reservoir or oil tank is about two gallons. It may be filled by either of two methods; that is through the breather tube in which there is a strainer or by means of the pump cover plate on the left-hand side of the motor.

The oil is drawn from the reservoir by means of a plunger pump, which is driven off the camshaft by spiral gears, and takes the oil from the reservoir in the bottom of the crankcase and sends it through the sight feed on the dash. The oil then flows back into the crankcase and supplies the splash chambers with oil.

The troughs are of such a depth that an adequate amount of oil will be held in them to

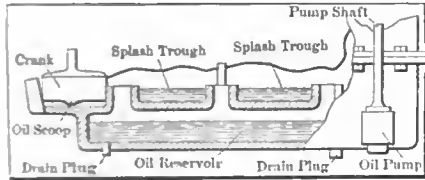

Fig. 5—Vertical section through Colby crankcase, showing location of troughs and pump

permit the bottom of the connecting rods to splash into the oil at any normal inclination of the car. When the oil overflows the trough wall it will drain back into the reservoir in the base. There are two large overflow stand pipes of elliptical shape. The purpose of making these overflow holes large is to allow the oil to drain from the splash troughs into the base as quickly as possible in case of an oversupply getting into the crankcase.

Between the two central splash troughs there is a solid wall of metal which is of the same height as the other trough walls. It does not form the enclosing wall of the overflow pipes as the other divisions between the trough do, but is pierced by two holes which form a communication between the two central troughs.

The oil is picked up by the copper scoops on the bottom of the connecting rods and thrown in the form of a fine spray up into the cylinders and the several bearings.

The train of gears which drives the camshaft on one side of the engine and the pump and magneto shaft on the other, are lubricated by the oil which they pick up from the trough which is in the bottom of the gearcase. This trough or oil well catches a supply of oil from the splash of the connecting rods. The gears dip into the oil and pick it up, thus carrying it to the top of the gearcase and into the bearings located in the case.

On the right-hand side of the oil reservoir there is a pet-cock at the correct level at which the oil must be kept. There is a large drain plug under the rear end of the base through which the oil may be drained completely out of the crankcase whenever the same is being cleaned.

The transmission and differentials are packed in grease, while the other bearings all over the car are taken care of by means of compression grease cups or oil holes, as the case may be.

**SELF-CONTAINED FIAT OILING SYSTEM**—The Fiat car is lubricated by an entirely self-enclosed force-feed system. The lower half of the crankcase which carries the oil is formed so that the rear or flywheel end of the reservoir is the deepest part of the casting. There the suction pipe from the tank to the pump enters the casting.

There is a large drain plug in the base of the oil reservoir just below the point at which the suction pipe draws its supply from the oil in the tank.

The level of the oil in the crankcase is determined by removing the inspection cover provided for this purpose on the bottom half of the base chamber. The proper level to keep the oil is about one inch below the cover.

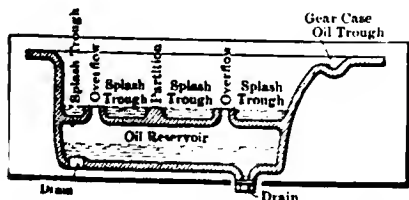

Fig. 6—The oil reservoir of the Moon car is formed by the base-chamber of the motor

A rotary gear oil pump, driven off the camshaft, lifts the oil from the reservoir through the suction pipe and forces it through a lead to the main bearings, then through the crank hollow shaft to the connecting rods, whence the oil is thrown up into the cylinders by centrifugal force, thus filling the crankcase with an oil vapor which is sufficient to lubricate the cylinders under ordinary circumstances. When running at higher speeds, however, the oil supply to the cylinder walls may be increased by pressing a button located on the dash. This button controls a valve which admits oil to a lead to the cylinders directly from the pump.

A pressure gauge shows the pressure on the oil pump. When the motor is running at normal speed the gauge should show a pressure of somewhere in the neighborhood of two or three pounds. When the pressure runs up beyond this point oil should be admitted to the cylinders.

When starting the motor after it has not been in use for a long time, it will often be found that the oil pump will not perform its functions properly. To aid the pump to draw properly in a case of this kind, a priming cock is placed on top of the oil pump, through which a little oil may be poured.

The gear box is kept filled to the level of the top of the gear shafts with medium grease. An examination of this bearing is advisable every two or three weeks.

**OILING SYSTEM OF PACKARD CARS**—The Packard 1912 cars are lubricated by means of the splash system. The connecting rods dip into the oil, which is held at the proper level in a series of splash troughs in the crankcase of the motor. The splash of the rapidly revolving connecting rods into these pools of oil generates an oil mist which entirely fills the crankcase and lubricates all moving parts located within the crankcase.

The oil supply is carried in a tank which is entirely separate from the crankcase and is located on the left-hand side of the motor. The tank is made of copper and cylindrical in form. The copper construction of this tank and its location between the two middle cylinders, ensure a warm temperature for the oil while the motor is running. The tank is filled through a filler opening in the

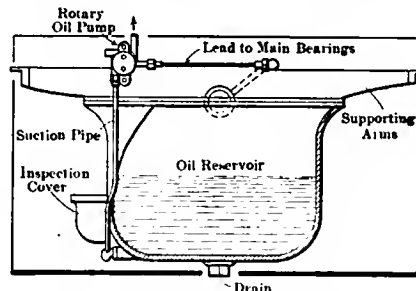

Fig. 7—Lubricating system of the Fiat, showing oil reservoir and oil suction pipe

top in which there is a wire gauze strainer which removes any foreign matter which happens to be in the oil. The two breather pipes from the front and rear crankcase compartments pass vertically through the oil tank. The oil flows from the oil tank through a pipe that leads out of the bottom and in which there is a three-way cock, which if turned towards the front of the motor completely shuts off the oil from the tank. Turned so that the handle is pointed transversely across the motor, the oil will drain off the tank; while when turned towards the rear of the motor the oil is fed to the pump.

The oil pump is located on the left-hand side of the crankcase at about the center of the engine in a longitudinal direction. It is on the outside of the crankcase directly below the oil tank. When the cock is turned to the rear of the engine and the motor is running, the pump will take the oil from the feed pipe and force it to the two sight feeds, located on the dash. The oil then drops through the sight feeds and flows through one lead to the rear crankcase compartment and through the other to the forward one. The pump is driven by means of a worm gear off the exhaust camshaft, and has two adjustable plungers, one for each of the two leads just described.

The oil carried in the copper tank is in reality the reserve supply of oil. That is, its purpose is to replenish the supply in the crankcase as it is burned up. Before starting the oil should always be put first into the crankcase so that the level therein is sufficient for the splash. To determine this level there are two pet-cocks on the left-hand side of the bottom of the crankcase.

The stroke of each pump plunger is independently adjustable. To increase the flow of oil in either lead, the adjusting screw and check nut should be turned downward for the plunger which governs the supply to that lead.

About every 1000 miles the old oil should be drained out by removing the drain plug in the bottom of each compartment in the crankcase. The crankcase should then be flushed out with kerosene, and, after this has been cleaned out, refilled with new oil.

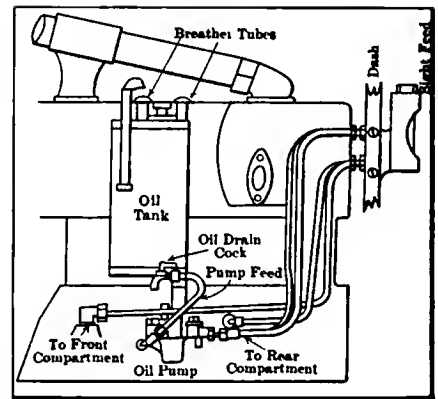

Fig. 8—Oil tank and connections for lubricating Packard cars of the latest type

**RENAULT OILING SCHEME**—The Renault cars are lubricated by the splash system. The oil is carried in the crankcase, which is filled through a filler opening located on the left-hand side of the motor just above the front axle of the car. The oil is taken by means of a pump driven by an eccentric and eccentric rod off the camshaft, and forced through a series of sight feeds located on the dash.

The sight feeds are marked by letters which stand for the French names of the parts which are taken care of by each of these oil leads. The leads are marked as follows: M.D., M.C., M.V. These three go to the motor itself, while the other two marked C.V. and E.D. (or E.A.) go to the gear box and rear axle, respectively.

The lead marked M.D. (moteur distribution) runs to the front main bearing; that marked M.C. (moteur central) to the central main bearing, and the one indicated by M.V. (moteur volant) to the rear of flywheel bearing. The amount of oil passing through each of these sight feeds may be adjusted to the requirements of each by turning the milled screws on top of the sight feed.

The connecting rods pick the oil from the series of troughs or compartments into which it is divided and throw it up into the cylinders. Besides lubricating the cylinders the oil is caught up by channels located in the upper part of the crankcase. These channels run longitudinally along the crankcase and are provided with small oil ducts above each bearing of the crankshaft. The oil will flow through these ducts by gravity to the bearings and from there into centrifugal oil rings on the shaft where it is naturally thrown by centrifugal force to the outer circumference of the ring.

Centrifugal force sends the oil into the crankpin, which has an opening so as to allow the oil to flow into the connecting rod bearing. The wrist pin will be lubricated also by the oil which works its way up from the splash, as well as that which is thrown there by centrifugal force.

To keep the oil in the splash troughs at constant level, the crankcase is divided into four transverse divisions. These may be put into communication with each other by means of a four-way cock which also drains the crankcase, separates the compartments and allows the oil to overflow to the correct level when there is too much oil in the splash troughs.

The change-speed box is packed in oil and grease which should be replaced occasionally. This can be done by removing the inspection cover. The flow through the sight feed into the lead to the change-speed box should show about fifteen drops per minute.

The remainder of the bearings all over the car are provided with grease cups or oilers.

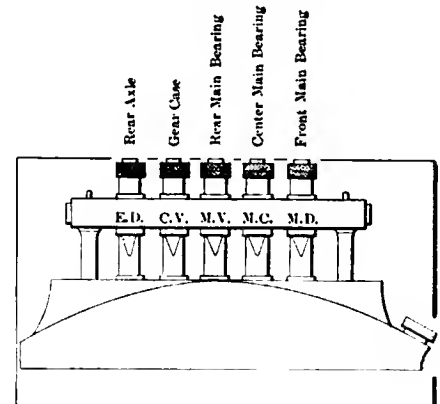

Fig. 9—Sight feed for oil connection on dash of Renault cars, with characteristic marks thereon

# When Judgment Whispers Don't

## A Series of Abbreviated Injunctions

- Don't discourage racing events and contests simply because they are difficult to control.
- Don't overlook the value of a "try-out" of an automobile under racing conditions—the weak spots float to the top.
- Don't try to build automobiles on a basis of pure theory—a real test welds theory to practice.
- Don't leave it to the purchaser to do the testing for the purpose of fixing the value of the product.
- Don't overlook the quality of the purchaser's money or the necessity of giving him an equivalent in the shape of a good automobile.
- Don't take it for granted that the automobile as made in your plant is good—a rigorous grind in a contest will develop that fact.
- Don't lay too much store upon circular track work—there is more to be learned during the length of a tour.
- Don't expect the control body to furnish honesty for you—it will have trouble enough keeping its own forces on the straight and narrow path.
- Don't be discouraged if a few false steps are to be found in tracing the past of contests—you have the whole future before you.
- Don't overlook the fact that however long the past may be it is but a moment as compared with the duration of the future.
- Don't mope if you are beset by a certain measure of failure—just make it a small percentage of the total and let the rest be success.
- Don't imprison a good idea in a poor setting—referring to an automobile, the good ideas will produce the right result if the car as a whole has been given a fair measure of attention.
- Don't practice mistakes after you find them out—the situation then becomes malicious.
- Don't incline the ear to drink in the story of the type of salesman who talks about everything but the subject in hand.
- Don't race with your money to put it in the coffers of the second-hand man before he races with the automobile to see if it is any good.
- Don't allow your incredulous smile to be supplanted by a serious look if the second-hand man gives you a more alluring version of the same story.
- Don't tap the boundless knowledge of the knave; there is no part of it that can be of any service to you.
- Don't permit yourself to be captivated by individuality; perhaps you need a good automobile instead.
- Don't pursue the business of buying an automobile according to a system that differs from the methods that you employ in the buying of real estate.
- Don't accept a demonstration if the car used has tires that are larger than the tire equipment of the automobile that you are taking an interest in.
- Don't overlook the importance of taking a demonstration in the particular automobile that you are to get.
- Don't harbor the fear that you will be giving the salesman too much trouble if you make him demonstrate the very automobile that you buy.
- Don't be satisfied with a wretched top on a good car—someone will take you for a ragman.
- Don't go in quest of a fool-proof automobile unless you belong to that fraternity.
- Don't expect that intelligent qualities will reside in a fool-proof car; intelligence never keeps such bad company.
- Don't cement your views to an incongruity, which is all that happens if you buy a car that is not in accord with your needs.
- Don't mistake a catalogue for the Bible, or forget that the maker's guarantee is in the back of the catalogue.
- Don't expect any more of redress from the maker than you will find reflected in the printed guarantee.
- Don't allow a salesman to make so little of you as to try to make you believe that his private guarantee will be underwritten by the maker of the car.
- Don't put your common sense up in camphor balls while you go to buy a car.
- Don't forget that you would have a fine automobile if you received the square root of the promises that are too often made.
- Don't boast of the speed that you can make with your car—somebody might get the impression that you are intemperate.
- Don't preach the doctrine of infallibility in connection with automobiles; the success of the automobile business depends upon the ultimate termination of the life of the cars.
- Don't assume that a good automobile should wear out before the purchaser gets a chance to pay for it.

## Storage Battery Charging Equipment

THE study of the storage battery and its ailments is a subject which has not in the past received the attention it deserves at the hands of the average motor garage owner, and their charging is frequently placed in the hands of a youth who has no qualifications for undertaking this important duty, and yet on its proper discharge is frequently dependent the whole pleasure of the run. No garage owner who is alive to the welfare of his business can afford to ignore the advantages resulting from the installation of an up-to-date, efficient charging plant.

The storage battery, if properly looked after, is a piece of apparatus which will last for years, but no accessory on the car can be spoiled with such ease, a short circuit being sufficient to ruin the best of cells. The question then arises as to what method of charging best fits in with local conditions. In the towns it is an inexpensive matter to install a suitable plant, as a supply of electricity is almost always available, be it alternating or continuous.

CHARGING FROM A MAIN.—Should it not be known what the supply is, this can be easily ascertained from the supply company. If alternating current only is available, some form of trans-

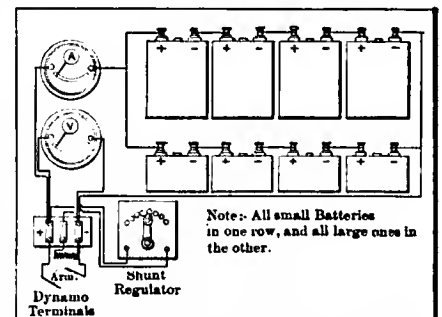

Fig. 1—Illustrating method of charging by a dynamo

former or rectifier is essential to convert it into continuous or uni-directional current, as alternating current theoretically surges backward and forward many hundreds of times a minute, first in a positive direction, then in a negative one, and if a storage battery is connected to this no charge is retained.

**CHARGING FROM ALTERNATING CURRENT.**—The transformer usually used consists of a motor wound for the alternating current circuit driving a continuous current dynamo; this set sometimes consists of a separate motor on a base coupled to a dynamo, but more usually the motor and dynamo are combined in one frame. The voltage on the secondary side of these transformers is always kept low in order that no waste is necessary in charging a small number of batteries, which will be explained later.

The rectifier is another method of converting alternating to uni-directional current for battery-charging purposes. The principle of the rectifier is to collect all positive and negative impulses and direct them to their respective terminals. It is usually made up of two parts—the incoming high voltage is led to a step-down static transformer, which reduces the voltage to a low figure, such as 6-8 volts, and this is then carried to an electro-magnetic rectifier, which synchronizes with the periodicity of the circuit on which it is fixed.

**CHARGING FROM CONTINUOUS CURRENT MAINS.**—If the supply is continuous current the choice of methods for charging is very much wider. The simplest, but by far the most extravagant, method of charging is by the use of lamps or resistances direct off the mains. This can be done by removing a lamp from its holder and inserting an adapter to which flexible leads are connected. A lamp or lamps should then be placed in circuit with the storage battery it is desired to charge, having first ascertained which is the positive and which the negative wire. This can be done by holding both wires in a cup of clean water about one-quarter of an inch apart with the current on, when bubbles will be seen to form on the negative wire. A good average rate of charge is 2 amperes for an ignition cell, and it will be necessary to connect six 16-cp. carbon lamps in series with the battery on a 200-volt circuit to carry this current, and half this number on a 100-volt circuit. This method of charging is not, however, to be recommended unless the light given by the lamps can be put to some useful purpose or charging is only very occasionally resorted to, as about 90 to 95 per cent. of the current consumed is absolutely wasted! Should, however, the number of batteries it is required to charge be large, say 30 to 40, then this method is to be recommended, as the above number of batteries will require practically the whole voltage of the mains if they are connected up in series.

The most efficient method, and the one usually adopted where it is required to charge a medium number of batteries off a continuous current supply, is by means of either a motor generator or a rotary converter.

The former consists of a motor wound for the voltage of the supply mains, coupled to a dynamo wound for a low voltage, such as 15 to 25. With these voltages the 4-volt batteries will be connected in three and five cells per row, and as many rows as the amperes will allow; the output of the dynamo can be varied

by means of a shunt regulator, according to the number of batteries it is required to charge.

The other method mentioned, viz., the rotary converter, consists of a single machine fitted with a commutator for collecting the current at each end, and a double set of conductors, viz., one set

of fine wires connected to the mains or motor side, and a set of coarse wires connected to the secondary or dynamo side. This machine can be wound to give the same output as the motor generator mentioned above. Its advantages are: Slightly greater efficiency owing to the elimination of one pair of bearings, and the fact that this machine has only one pair of field coils instead of two; greater compactness; and less cost due to less material required in its manufacture. As a set-off to these advantages, any regulation required in output must be obtained through a series regulator, which is less efficient than a shunt regulator, and somewhat more expensive, but this latter machine has proved itself the more serviceable.

**CHARGING BY DYNAMO.**—Should no electricity mains be available, the problem before the man requiring to charge batteries is more serious. Some form of power is, however, necessary to drive this dynamo, be it gas or oil engine, gasoline or water motor. If the dynamo is required solely for charging purposes, the power required from the prime mover will be very small, 1-3 hp. being sufficient to charge as many as nine 4-volt storage batteries, but it is usually wise to install a larger plant than this and use the surplus for lighting purposes, as not only is electric light the very best and safest illuminant for the garage, but its cost compares favorably with even oil lamps. For instance, it is possible to light fifty 10-cp. metallic filament lamps for less than 3 cents per hour!

Having decided to install a dynamo, the question of the most suitable voltage arises. For all-around purposes 2 volts will be found the most satisfactory. With this voltage it will be necessary to connect the 4-volt batteries to be charged in series rows of five per row. Care should be taken in connecting up these rows to put, as far as possible, batteries of an equal size in the same row, as otherwise a small battery placed in a row with large ones will get too heavy a charge or else cause the large cells to be charged at a slow rate, which latter course, while not damaging them, will lengthen the time taken unnecessarily.

When the dynamo is lighting lamps at the same time as charging batteries, the voltage can, by means of a shunt regulator, be reduced according to the number of batteries it is required to charge. Thus, should there be only three 4-volt cells the dynamo must only give 15 volts, and so on. The regulation of the output of the dynamo obtained in this way is not at all extravagant, as the power required to drive it diminishes in the same ratio.

Another method of charging storage batteries is by means of a bichromate battery, but this method can only be recommended for use in the hands of an expert. This primary battery consists of a porous pot in which is a zinc rod amalgamated with mercury. This pot is placed in an outer jar in which is a solution of chromic acid and sulphuric acid. To charge one battery four primary batteries should be used. Each cell will give 1.1 volts.—*The Motor Trader*, May 24.

**MERITS OF ZINC AND COPPER ALLOYS WITH ALUMINUM**—For cheap aluminum castings a 33 per cent. zinc alloy with fusion point about 470 degrees centigrade is preferable, but for castings which must be particularly light and are subject to considerable deformation stresses an alloy with copper, though much more difficult to cast, meets the requirements better. There must first be made an alloy of 50 per cent. copper and 50 per cent. aluminum, which requires high heat and causes the formation of oxides and ashes. Commercially pure aluminum is added afterward, until the copper content is reduced to about 7 per cent., and the alloy has then a fusion point between 560 degrees and 622 degrees centigrade.

**CANADIAN EXPORTS**—Automobiles to the value of \$43,650 were exported from Montreal, Canada, during the fiscal year of 1910, as compared \$28,400 worth of exports of motor cars in 1909. St. Johns, N. B., sent \$34,100 worth of automobiles to the United States in 1910, which was a decrease in comparison with the 1909 exports, when the value was \$37,770.

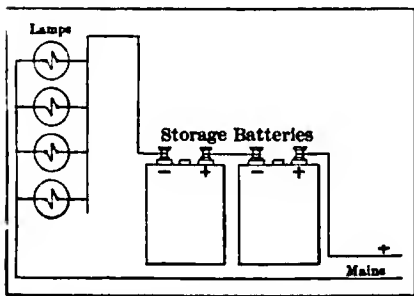

Fig. 2—Illustrating the method of charging a storage battery from a main, using lamp resistances for the purpose

## It Stands to Reason—

### (Remembering That the Exception Proves the Rule)

- THAT the advance guard among automobile designers is making progress every minute.
- THAT the purchasing public would be in poor business dogging the advance guard.
- THAT every device must be tried out before it is entitled to a certificate.
- THAT trying it on the "dog" is the regular thing.
- THAT the "dog" ought to know when he gets enough.
- THAT trouble will come soon enough—lubricate the parts and don't wait until they signal that they are in distress.
- THAT the success of any art depends upon a certain amount of "try-out" work.
- THAT a great many things are being tried out that will never be standardized.
- THAT standardization comes when the public puts its stamp of approval upon the product.
- THAT sanctioned practice is really the practice that pulls money out of a prospective's pocket.
- THAT a little temporary success on the part of an upstart is in the nature of a remote contingency as compared with sanctioned practice.
- THAT to get the opinion of an upstart he will convey the impression that he is the whole "cheese."
- THAT the men pulling in the traces and making the wagon of progress go are not even groaning under the load.
- THAT all the noise comes from the fellow who gambles on an idea.
- THAT the automobile business in the main is an established institution remote from the gambler's pavilion.
- THAT there are many little odds and ends attached to the automobile art that can well be dispensed with.
- THAT the shepherd of the automobile flock is counting his sheep with a good deal of care these days and the goats are being separated out.
- THAT there can be no retreat from the present status of the automobile business—advance is the order of the day.
- THAT there is too much merit in good means of transportation to permit the project to falter by the wayside.
- THAT most of the complaining that is heard is from the type of man who has insufficient funds to buy a good automobile and too little nerve to risk the other kind.
- THAT the conflict of thought as it affects the designing problem is being reduced to its lowest terms.
- THAT the designer who chums with a poor original idea might better copy his master.
- THAT every designer has a master in precedent.
- THAT taking due notice of sanctioned practice is no reason why an improvement should not be made in the due course of time.
- THAT failure is due to the man who quits improving because he has an investment in perishable tools.
- THAT the purchasing public does not care a rap about the investment considerations—they are willing to foot the increased bill if the product reflects the difference.
- THAT the man who does not know how to act wisely can get his marching orders from the purchasing public.
- THAT the jaded nerves of a worn-out motor are scarcely to be improved by a monkey wrench in the hands of a novice.
- THAT too many automobiles are put awry by the careless use of convenient tools.
- THAT an automobile should not be subjected to a surgical operation if it is going about its business and keeping still.
- THAT good service is the shadow of good management.
- THAT short life is the product of a speed lust.
- THAT the user of a car holds no brief to tell the designer how to improve upon his stock.
- THAT the designer of an automobile is in poor business plugging up his ear against the complaints of users.
- THAT success in the designing office comes with vigilance and alertness.
- THAT satisfaction on the road is a matter of care and caution.
- THAT the designer of an automobile has no more right to perpetrate a poor product than a user has to abuse a good car.
- THAT a happy situation is reflected when the designer and the user work together.

## Short Stories of Current Interest

### Unraveling the Puzzling Situations

*Of the many things that automobilists take an interest in, some of them are on debatable ground, but it is generally true of such matters that they can be reasoned out even after algebraic formulæ fail to serve the intended purpose; it is the idea here to reason out some of these situations.*

EVERY known element and compound, if it is changed from a liquid to a gas, must boil in the process. Water boils at 212 degrees Fahrenheit under a pressure of one atmosphere. Other liquids have various boiling points, and gasoline, for illustration, if it is to best serve the purpose for which it is

used in automobiling, must be so compounded that it will boil at the surrounding temperature. It is a too common belief that nothing can be made to boil unless it is put into a pot or other form of receptacle and placed over a fire. This belief melts under the impetus of secondary thought, especially when it is remembered that some elements and compounds obtain only in the gaseous state under the normal conditions of temperature as we know it. The more volatile constituents of the hydro-carbon that is used to obtain gasoline are in gas form at the normal temperature, and for that matter it is scarcely believed that anything below hexane is sufficiently stable to constitute a good liquid to put in the gasoline tank. In the various fractions of hydro-



carbons, so it would seem, there is a wide choice, beginning with the fractions that boil at the temperature of the surrounding air are slightly below and ending with the fractions that can only be made to boil when the air that is sent through the carbureter is preheated. The right time to stop off is when the fractions are so non-volatile that they cannot be induced to boil excepting in the greater heat of the combustion chamber.

WHEN carbon forms in the combustion chamber of the cylinder of a motor the operator of the car is made aware of the fact due to the cranky performance of the car under such conditions, and yet the explanation for this cranky performance presents a difficult situation to cope with. It is claimed by many designers of motors that the thermal efficiency will be on a higher plane if heat is prevented from getting out of the cylinder into the cooling water, and a coat of scale over the combustion chamber surfaces retards the flow of heat through the cylinder to the cooling water, so that in a sense the very deposit of carbon to which exception is taken is beneficial in its presence because it retards the flow of heat and conserves the useful measure of the same, thus increasing the power of the motor and decreasing the necessity for circulating cooling water. The effect of carbon in the combustion chamber is more marked as the compression of the motor is increased, and we must reach the conclusion that the placing of a layer of scale over the inner surface of the cylinder has the same effect to some extent as increasing compression. According to this method of reasoning it would be possible to increase the efficiency of the motor by putting a coat of scale over the flame-swept surfaces as well as by increasing the compression, since both methods seem to have the effect of increasing the rate of flame travel in the burning mixture. Following this thought a little longer makes it possible to reach the conclusion that there might be some advantage in running a motor under conditions of relatively low compression and courting the growth of the coat of carbon over the

flame-swept surfaces in the cylinders. It has been found in practice that a motor acts precisely the same if the compression is 95 pounds (absolute) per square inch as when the compression is 10 or 15 pounds lower, and a coat of scale is permitted to grow over the flame-swept surfaces. It has been found also that with a compression of about 75 pounds per square inch (absolute) the effect of carbon deposit is materially reduced, and it might be that with a pressure of 60 pounds (absolute) per square inch the effect of the carbon growth would be so reduced that its presence might be disregarded.

WHILE the Society of Automobile Engineers were attending the Summer Meeting at Dayton, Ohio, a few days ago, there was quite a little discussion bearing upon the relation of a designing engineer to the man who purchases and uses a freight automobile. Some of the experts present advocated the employment of a second engineer, whose duty it would be to tell the designing engineer what the purchaser wants and whose second duty would fall in the direction of telling the purchaser how to conserve his investment and get a return on the same. There is some merit in the idea of using two kinds of engineers in this large commercial undertaking. It must be remembered that the designing engineer in the plants in which automobiles are made has a strong influence brought upon him for the worthy purpose of standardizing the output of the plant, and it would be nothing very unusual were the engineer to encourage the thought that one type of freight automobile should serve all the different kinds of users, and yet the point must not be overlooked that the wish is father to the thought. It is highly improbable that one type of automobile can be made to serve under all the commercial conditions to which freight automobiles offer advantages, and it is more than likely that an efficiency engineer who studies the wants of users of freight automobiles will be the best judge of the modifications of the main plan that must be indulged in ere the result will be satisfactory.

# Calendar of Coming Events

## Handy List of Future Competitive Fixtures

### Race Meets, Runs, Hill-Climbs, Etc.

July 5-22.....Winnipeg, Man., Fourth Canadian Competition for Agricultural Motors.  
 July 7.....Taylor, Tex., Track Races, Taylor Auto Club.  
 July 8 or 15.....Philadelphia, Track Races, Belmont Park, Norristown Auto Club.  
 July 14.....Philadelphia, Commercial Reliability Run, Quaker City Motor Club.  
 July 15.....Guttenberg, N. J., Track Races.  
 July 15-17.....St. Louis, Mo., Reliability Run, Missouri Automobile Assn.  
 July 17-19.....Cleveland, O., Three-Day Reliability Run of the Cleveland News.  
 July 17-22.....Milwaukee Reliability Run, Wisconsin State Automobile Association.  
 July 21-22.....Brighton Beach, N. Y., Twenty-four-Hour Race.  
 July 20-28.....Minneapolis Reliability Run, Minnesota State Automobile Association.  
 Aug. 1.....Chicago, Ill., Commercial Reliability Run, Chicago Evening American.  
 Aug. 3-5.....Galveston, Tex., Beach Races, Galveston Automobile Club.  
 Aug. 12.....Philadelphia, Reliability Run, Quaker City Motor Club.  
 Aug. 12.....Worcester, Mass., Hill Climb, Worcester Automobile Club.  
 Aug. 17.....St. Louis, Mo., Reliability Run, Missouri Automobile Assn.  
 Aug. 25-26.....Elgin, Ill., Stock Chassis Road Race, Chicago Motor Club.  
 Sept. 1.....Chicago, Ill., Commercial Reliability Run, Chicago Motor Club.  
 Sept. 1.....Oklahoma, Reliability Run, Daily Oklahoman.  
 Sept. 2-4.....Brighton Beach, N. Y., Track Races.  
 Sept. 2-4.....Indianapolis Speedway, Track Races.  
 Sept. 4.....Denver, Col., Track Races, Denver Motor Club.  
 Sept. 7-8.....Philadelphia, Track Races, Philadelphia Auto Trade Association.  
 Sept. 7-9.....Hamline, Minn., Track Races, Minnesota State Automobile Association.  
 Sept. 12-13.....Grand Rapids, Mich., Track Races, Michigan State Auto Association.

Sept. 15.....Knoxville, Tenn., Track Races, Appalachian Exposition.  
 Sept. 16.....Syracuse, N. Y., Track Races, Automobile Club and Dealers.  
 Sept. ....Denver, Col., Track Races, Denver Motor Club.  
 Oct. 3-7.....Danbury, Conn., Track Races, Danbury Agricultural Society.  
 Oct. 7.....Philadelphia, Fairmount Park Road Race, Quaker City Motor Club.  
 Oct. 9-13.....Chicago, Ill., Thousand-Mile Reliability Run, Chicago Motor Club.  
 Oct. 16-18.....Harrisburg, Pa., Reliability Run, Motor Club of Harrisburg.  
 Oct. ....Atlanta, Ga., Track Races, Atlanta Automobile Assn.  
 Nov. 1.....Waco, Tex., Track Races, Waco Auto Club.  
 Nov. 2-4.....Philadelphia, Reliability Run, Quaker City Motor Club.  
 Nov. 7-10.....Los Angeles-Phoenix Road Race, Maricopa Auto Club.  
 Nov. 9-11.....San Antonio, Tex., Track Races, San Antonio Auto Club.  
 Nov. 10.....Phoenix, Ariz., Track Races, Maricopa Automobile Club.  
 Nov. 28-30.....Savannah, Ga., Vanderbilt and Grand Prix Races, Savannah Automobile Club.  
 Nov. 30.....Los Angeles, Cal., Track Races, Motordrome.  
 Dec. 25-26.....Los Angeles, Cal., Track Races, Motordrome.

### Foreign Fixtures

July 9.....Sartbe Circuit, France, Grand Prix of Automobile Club.  
 July 13-20.....Ostend, Belgium, Speed Trials.  
 July 21-24.....Boulogne-sur-Mer, Race Meet.  
 Aug. 6.....Mont Ventoux, France, Hill Climb.  
 Sept. 2-11.....Roubaix, France, Agricultural Motor Vehicle Show.  
 Sept. 9.....Bologna, Italy, Grand Prix of Italy.  
 Sept. 10-20.....Hungarian Small-Car Trials.  
 Sept. 16.....Russian Touring Car Competition, St. Petersburg to Sebastopol.  
 Sept. 17.....Semmering, Austria, Hill-Climb.  
 Sept. 17.....Start of the Annual Trials Under Auspices of l'Auto, France.  
 Oct. 1.....Gailion, France, Hill-Climb.  
 Oct. 12-22.....Berlin, International Automobile Exhibition.



# THE AUTOMOBILE

Vol. XXV Thursday, July 6, 1911 No. 1

## THE CLASS JOURNAL COMPANY

H. M. SWETLAND, President  
A. B. SWETLAND, General Manager  
231-241 West 39th Street, New York City

### EDITORIAL DEPARTMENT

THOS. J. FAY, Managing Editor  
GEORGE M. SCHELL, Associate Editor  
JAMES R. DOOLITTLE HUGH P. MacCONNELL  
HANS WEYSZ

### ADVERTISING DEPARTMENT

W. I. RALPH, 1035 Old South Bldg., Boston  
C. H. GURNETT, } 910 South Michigan  
L. G. VOGEL, } Avenue, Chicago  
T. B. VAN ALSTYNE, New York and Phila.  
H. L. SPOHN, New York  
LOUIS R. SMITH, New York  
FRANK B. BARNETT, 309 Park  
Building, Cleveland  
H. H. GILL, 627 Ford Building,  
Detroit

Cable Address - - - - - Autoland, New York  
Long Distance Telephone - - - - - 2046 Bryant, New York

### SUBSCRIPTION RATES

United States and Mexico - - - - - One Year, \$3.00  
Other Countries in Postal Union, including Canada - - - - - One Year, 5.00  
To Subscribers—Do not send money by ordinary mail. Remit by Draft,  
Post-Office or Express Money Order, or Register your letter.

### FOREIGN SUBSCRIPTION AGENTS

ENGLAND:—W. H. Smith & Sons, Ltd., 186 Strand, London, W. C., and all book-  
stalls and agencies in Great Britain; also in Paris at 248 Rue de Rivoli.  
FRANCE:—L. Baudry de Saunier, offices of "Omnia," 20 Rue Duret, Avenue  
de la Grande Armée, Paris.  
GERMANY:—A. Seydel, Mohrenstrasse 9, Berlin.

Entered at New York, N. Y., as second-class matter.  
The Automobile is a consolidation of The Automobile (monthly) and the Motor  
Review (weekly), May, 1902, Dealer and Repairman (monthly), October, 1902,  
and the Automobile Magazine (monthly), July, 1907.

WIDE interest is being taken in the types of motors that do not depend for their proper functioning upon poppet valves, and the supporters of the automobile industry are about to have an opportunity to inspect and try American-made Knight sleeve types of motors, as they are being manufactured by four companies of tried experience. In addition to this concrete effort, there is a strong undercurrent, with particular attention being paid to other forms of this broad idea, and the interested investigator will be struck by the diversity of effort and the impetus that is being given to original investigation in the face of the fact that designers who have had their nests well feathered are trying to teach the world to accept their marvelous handiwork as the last word.

\* \* \*

TO the man who rests upon his hard-earned laurels, an early death and a heavy monument is all that the world affords; but we cannot bring ourselves to believe that glory in this form has any more compensations than will come to the progressive struggler who refuses to believe that finality hovers in the offing, and who goes on sweeping obstacles aside, holding tenaciously to the idea that there is something better higher up. As against the loud cry deprecating the annual model idea, the automobile industry is confronted by a more persistent and potent situation and the patrons of the industry are about to enjoy an opportunity to test the acumen of the builders, who seem to go on the principle that if there is nothing ventured there is nothing gained. It would be a foolhardy

attempt on the part of a novice to try to market something new just because it is different; but there is a great difference between an innovation for sensation's sake and the supplying of a real demand.

\* \* \*

JUST as refined society is conspicuous for its well-bred silence, so it may be said of a motor. If it does its work silently and well it will occupy a social throne motorwise that will attract the discriminating attention of the man who expresses a preference for the refined instead of encouraging the antics of the brawler. The time was when a silent motor was past believing, and the only hope that was entertained had for its foundation the thought that quite a little of the disconcerting sounds might be wrung out of the average motor. It is not believed that the purchaser of an automobile will concern himself overmuch relative to the scheme of design and the details of construction of motors in general, provided motors as used will do the work for which they are intended; on the further count, however, that the user thereof can take the evidence of his own ears and say to himself that the performance of the motor is silent.

\* \* \*

UNEXPECTEDLY the builders of well-performing motors from the noise point of view were confronted by a strange situation. When they got the noise out of the valve mechanism they found that it had taken up its abode in the halftime gear system and in the drive for the magneto, water pump, and lighting dynamo. These relatively puny noises must have been in motors all of the time, but they sank into insignificance in comparison with the considerable clatter of the valves, only to be discovered when these great noises were removed. It was only half the battle to pay attention to the proper contriving of valve mechanism, and the other half of the struggle is being taken care of by the introduction of silent chain drives. Fortunately for the builders of all types of motors, the use of the silent chain is free to all, and we gather the impression that even the most inexpensive types of poppet-valve motors, as they will find a use in popular-priced cars, will vie in point of silence with their more pretentious brothers, due to the use of chain drives and the strangling of the grind that comes in the trail of ill-fitting gears.

\* \* \*

FLEXIBILITY is the condition that makes it possible for a locomotive to start a train of 100 freight cars, and this desirable property is at no greater cost than the use of a spring in the coupling; and this flexibility, in addition to facilitating the work of starting, has a marked and favorable bearing upon the equipment. In the same way the presence of flexible members in the driving equipment of an automobile facilitates in the acceleration of the mass and saves the members in the machinery equipment from the ills of shock. There are two ways at the disposal of designers to overcome the ills of shock, one of which has to do with the use of dynamic steel at a price; but the second and perhaps the best way lies in the elimination of the shock. One of the distinct and desirable advantages attending the use of the silent chain lies in this very flexibility, the presence of which is the best guarantee that shock does not have to be entertained.

# Fate of Dirt Tracks in Balance

## M. C. A. to Take Action on Racing Next Month

*Whether automobile racing on circular dirt tracks shall be continued or not on present lines will be the subject to be considered at the next meeting of the Manufacturers' Contest Association. The proposition will be taken up from all viewpoints, and the action that develops will likely be along the line of restricting racing of this kind. One point in particular will be considered, the methods of settling dust by other means than water in preparing for races. Sweeping prohibitory action would leave New York without racing representation for the present at least.*

**W**HAT shall be the fate of dirt-track racing is a problem that has an interest for a circle considerably wider than that comprising motordom and it will be settled, according to announcement, by the Manufacturers' Contest Association at its coming meeting in August.

Automobile racing on the general run of county fair tracks that have not been specially prepared for such use has its dangers and certainly lends an element of peril to contests that is absent on the speedway or upon the specially prepared dirt track.

If general action should be taken by the association barring racing on all dirt tracks the situation in New York would be disconcerting. One thing seems to be certain and that is that the present situation will not be broadened. Therefore if action is taken it will likely be restrictive.

The association has issued the following bulletin covering the subject:

"One very important subject which will be given most careful consideration at the general meeting of the Manufacturers' Contest Association, to be held in August will be the question of racing upon circular dirt tracks. All over the country there are in existence one-mile circular dirt tracks built for horse-racing. The popularity of the automobile and of automobile competitions has prompted county and State fair organizations to feature racing among the head-liners of the "big days." In addition to this, racing events on circular dirt tracks are being advertised by individual promoters who have in mind the possibility of a considerable financial return in the way of gate money.

"At a meeting of the Active Rules Committee held in Detroit on June 19 it was the consensus of opinion that decisive action should be had at the August meeting for the restriction of circular track racing. Whether racing of this kind upon mile dirt tracks should be legislated against by the governing body, or whether sanction for circular-track events should be granted only after an entire reconstruction of the track surface and surroundings and some adequate provision other than the use of water has been made for laying the dust, are open questions. In any case, the situation requires decisive action."

### Everybody Experimenting with Motors

Recent developments with regard to the sleeve type of motor have uncovered a tremendous line of activity in motor building. It may be said with conviction that practically every manufacturer of automobiles in the world has been experimenting with some new kind of a motor this year.

Many of them are doing this openly, but in the majority of cases the investigations have been carried along with more or

less secrecy. In a few instances the fact that the experiments are being made has been officially denied but unofficially confirmed.

The result of course is problematical, but with the adoption of the sleeve motor by several well-known companies, it is apparent that most of the others have been active in looking into the merits and demerits of various sorts of motors not represented by the formal poppet valve types.

Of these there are fifty-five different species ranging through the entire gamut of motor construction. The poppet valve motors generally follow somewhat similar lines and opposed to them is a staggering array of other varieties.

The field of choice offered to the manufacturer is wide and as a consequence the investigation and experimentation have been conducted upon broad lines.

### Blue Book Fleet to Rival "Stunt" Cars

With its road work department equipped with three six-cylinder Thomas cars of high power, the Official Automobile Blue Book is about to enter upon its preliminary work for next year. The cars, manned by members of the staff of the publication, will start out this week on tours which for size and length rival the dreams of all the "stunt" car publicity agents rolled into one. The team will cover all the Blue Book routes lying between the crest of the Rocky Mountains and the Atlantic Ocean north of Miami, Florida.

All told, the routes foot up to a total of something over 75,000 miles and in addition to that vast amount of touring the cars will seek out other routes.

In making these tours the utmost pains are used to localize every landmark, branch road, fork, schoolhouse, cemetery and church so that the users of the routings may have the advantage of the careful work of the map-makers. Every branch road is covered with care, even though it does not form a part of any of the published routes. Every fork is investigated as to where it terminates.

Using a rapid schedule it will require all the time between now and the deadlock of Winter to cover the ground. The reason for this is that every road, whether it is a part of any route or not, is carefully measured with the odometer and checked with other instruments.

It is the announced intention of the management to enlarge and improve the Blue Book of 1912 along the same lines laid down in the current work. This will mean more detailed information about the roads and if possible more complete hotel directions.

### T. C. A. Warns of Speed Traps

SYRACUSE, N. Y., July 3—Automobilists of this city and vicinity are interested in the measures that are being taken by the Touring Club of America properly to warn drivers against the existence of speed traps, of which there are a number in this vicinity. They have been springing up of late through the mistaken zeal of that small but troublesome part of motordom known as speed maniacs. The T. C. of A. is taking measures to warn motorists of the traps and at some of them scouts are to be placed on Saturdays and Sundays to issue proper warning to tourists.

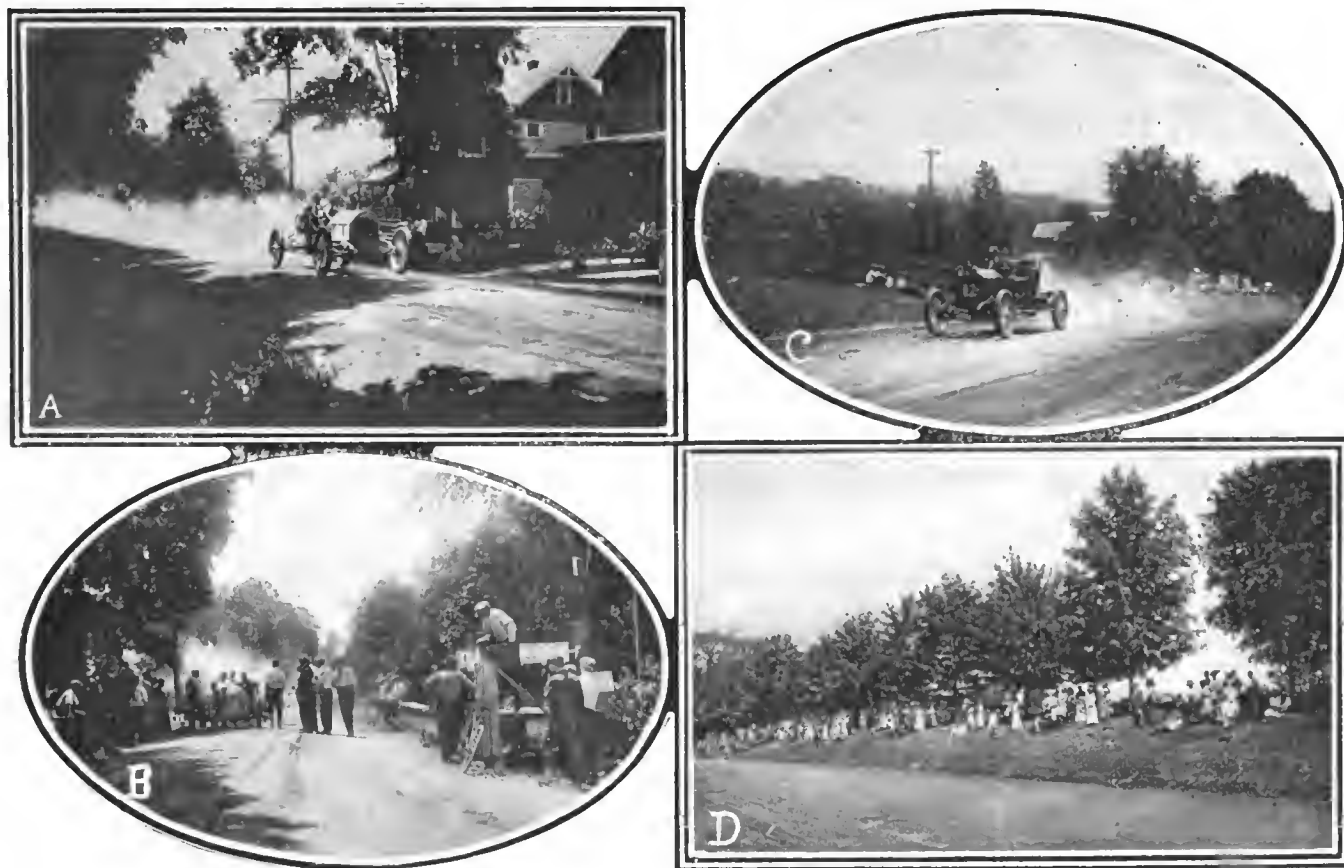

A—Paige-Detroit competing in first event. B—At the starting line on Ossining Hill. C—Wilson's National winning the amateur event. D—Summer visitors watched the races with much interest

## Nationals Sweep Ossining' Card

### Indianapolis Cars Win Four Races on Hill

Four events in which they were entered out of five programmed at the annual hill climb of the Upper Westchester Automobile Club fell to the lot of National cars on Saturday at Ossining, N. Y. The other race was taken by a Mercer car. There was little sustenance derived by the foreign speed monsters in this hill-climb as the 200-horsepower Fiat finished last in the Free-for-all with a balky carburetor and the special Mercedes could do no better than second in both events in which it started. A big crowd enjoyed the proceedings.

**O**SSINING, N. Y., July 1—Before a crowd of natives and Summer visitors estimated at about 6,000 persons the Upper Westchester Automobile Club conducted its annual hill climbing contest to-day under delightfully favorable conditions.

The hill was rather easy and was not long and all the cars experienced no trouble in negotiating it. The running off of the card proved to be a clean sweep for the fleet of Nationals that were entered in four of the events. The foreign speed monsters were obliged to bow to the flight of the powerful blue car driven by Len Zengel, who won fame ast Fall by annexing the Fairmount Park Race in a hair-raising finish.

In two events this car was first at the wire, they being its

division of Class C and the Free-for-all, in which it defeated such cars as the Arnold Fiat of 200 horsepower driven by Bruce-Brown and the Mercedes monster that ran so well at Indianapolis.

The first race on the program was originally intended for stock cars and was so carded, but its real status was Class E. There were three entries, a pair of Mercers and a Paige-Detroit. Mercer No. 1 proved the speediest and turned the hill in 48 1-5 seconds. The other Mercer was second, four seconds slower and the Paige-Detroit was placed third. The Mercers are considerably larger in piston displacement measurements than the Paige and all three competitors were actually stock cars.

The second race found three Nationals opposed to a Pope-Hartford. No. 4 made a fast climb in 38 seconds and won rather easily, with No. 6 National and the Pope-Hartford separated by only one-fifth of a second for the place. The National that finished last was only three-fifths of a second behind the Pope.

In the race for cars of from 450 to 600 cubic inches piston displacement National No. 8 made the fastest time of the day and won from the Indianapolis Mercedes by one-fifth of a second. The Pope was a distant third.

The club race for cars owned and driven by members of the Upper Westchester Automobile Club attracted only three starters. National No. 12 finished the climb in 45 1-5 seconds, beating the Stearns and the Mercer. There were handicap con-



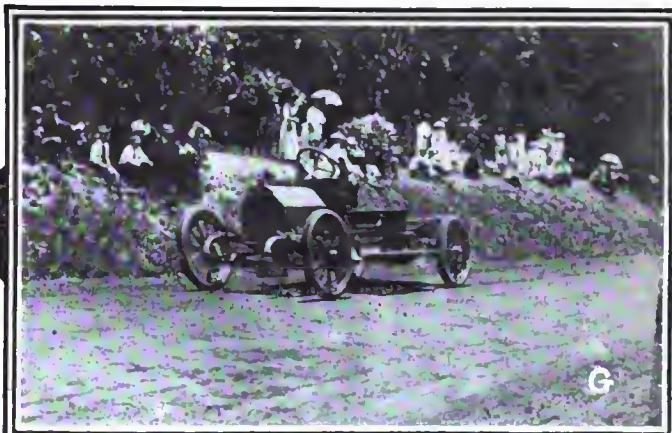
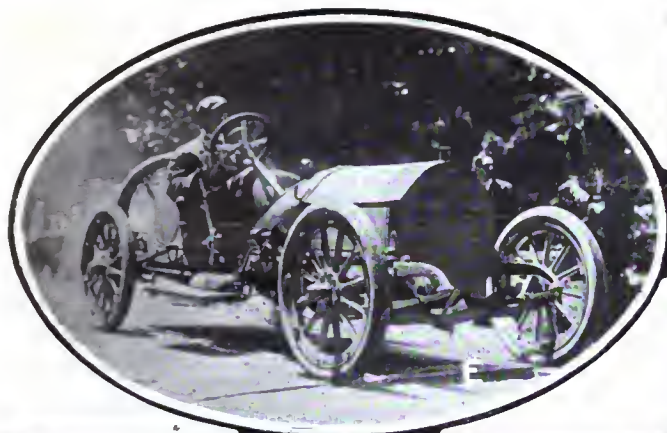

E—Winning Mercer car in event No. 1. F—Double winner of the day, a National. G—Stearns car made a good showing in club event. H—When the word was given to start in one race

ditions in this event but they did not serve to alter the placing of the cars.

The big race of the day was the Free-for-all, last on the program. In this there were five starters including two Fiats, Mercedes, Pope and National. The latter equaled its fast run in the class race mentioned above, 33 4-5 seconds. The second car turned up in the Indianapolis Mercedes, one second slower, while the fully equipped Fiat car, No. 14, was third in 37 1-5 seconds. The Pope came fourth and the big Fiat, coughing and sputtering with carbureter trouble, just managed to wobble past the finishing line in 42 4-5 seconds.

The event had a distinct flavor of finance about it as three of the competing drivers, all of whom hold professional credentials, are rated above the million-dollar mark. They are: Bruce-Brown, Wishart and Bragg. Three other drivers are also considered rich men in a comparative sense, Disbrow, Rutherford and Sherwood.

The hill is hardly long enough and difficult enough to afford a setting for a hard test. It is not equal in any way to Sunset hill that has been used heretofore. The starting point was at the limits of the village of Ossining on the north side and the course was laid out 2,814 feet toward the center of town. The whole hill has an average grade of 6 1-2 per cent. and a maximum of 11 1-2 per cent. There is one curve of about 15 degrees.

There was nothing that looked like an accident during the afternoon and the races were conducted with commendable speed after the first car was sent away. A. F. Camacho represented the Contest Board and A. J. McShane was referee. The summary:

Class E, Special for 160-300 Cars				
Number	Car	Driver	Position	Time
1	Mercer	Van Wyck	1	:48 1-5
3	Mercer	Sherwood	2	:52 1-5
2	Paige-Detroit	Craig	4	:58
Class C, Division 4, for 301-450 Cars				
4	National	Bragg	1	:38
6	National	Rutherford	2	:39 4-5
5	Pope-Hartford	Disbrow	3	:40
7	National	Tierney	4	:40 3-5

Class C, Division 5, for 451-600 Cars				
8	National	Zengel	1	:33 4-5
9	Mercedes	Wishart	2	:34
5	Pope-Hartford	Disbrow	3	:41
Class E, for Cars Owned and Driven by Members of Upper Westchester A. C.				
12	National	Wilson	1	:45 1-5
11	Stearns	Wallace	2	:47 2-5
3	Mercer	Sherwood	3	:51 2-5
Class D, Free-For-All				
8	National	Zengel	1	:33 4-5
9	Mercedes	Wishart	2	:34 4-5
14	Fiat	Stuart	3	:37 1-5
5	Pope-Hartford	Disbrow	4	:40 1-5
15	Fiat	Bruce-Brown	5	:42 4-5

### Newark Club Plans for New Home

NEWARK N. J., July 3—The New Jersey Automobile and Motor Club has inaugurated a campaign to raise \$25,000 for the erection of a country clubhouse. The plan provides for a nine-hole golf course. Several sites, within a short run of Newark, are under consideration. The club's present lease on the Lake Apshawa club house expires in 1912.

The contest committee of the organization is arranging for an endurance run to take place in September. While nothing definite has been settled on, the affair, it is said, will be either a twelve-hour or twenty-four-hour contest.

### Foster to Spend \$200,000,000 on Roads

PITTSBURG, July 3—County Road Engineer S. D. Foster has recently been appointed first assistant to E. M. Bigelow, Chief Road Engineer of Pennsylvania, who will have charge of the expenditure of more than \$200,000,000 for good roads in the Keystone State. It is likely that the Automobile Club of Pittsburg will take action expressing regret at his departure at the next meeting. Before Mr. Foster's leaving the employees of the county engineer's office presented him with a fine gold watch and fob.

# Big Crowd Sees Mile Record Fall

## Brighton Beach Two-Day Meet a Success

*Seventeen races, practically all of which developed a struggle somewhere in their various courses, as well as a mile trial against time that set a new mark for the distance, were the offerings set before the public at the two-day race meeting that was held at Brighton Beach July 3-4. The keenest and most spectacular of the struggles that were staged came in a race that gave little promise of any such thing, the free-for-all handicap of July 4, when an E-M-F racing car just lasted long enough to nose out a Pope-Hartford in the most remarkable finish ever made at the track.*

**T**O a full house the automobile racers played on Independence Day at Brighton Beach. The crowd of 5,000 persons who witnessed the races on the preceding day was tripled in honor of the holiday and all around it was a delightful and successful day's sport. There were seventeen races decided during the two days and for good measure the one-mile circular dirt track world's record was lowered by one-fifth of a second. Not an accident marred the sport during the running of the cards.

The feature race of the meeting was the struggle for the Remy brassard and the \$75 a week that goes to the driver of the winning car and as was predicted in *THE AUTOMOBILE* the big end went to the big special Benz car and the \$75 a week must be paid to Burman, unless he has some arrangement with the manager of his stable by which the "salary" will go into the stable's treasury to pay railroad fares and such things.

The "stable" which is managed by E. A. Moross, who also promoted the race meeting, did very nicely all told. Besides the brassard race, two Class E races were won by its representative in the person of another Benz car driven by Patschke.

In the bigger division of this class, however, something must have slipped for Simplex 2 took down first money on the opening day and National 33 gathered the shekels on July 4.

Despite these drawbacks the stable must have done well because the "gate" was satisfactory.

There were no stock car races and consequently the spectacle afforded was simply a spectacle, but it was a mighty interesting one.

The first event of the first day attracted a field of seven starters. The E-M-F entry got away flying and won all the way by a fair margin. Paige-Detroit 29 broke second and followed the pace for nearly 2 miles, when it gave way to the Lancia. At the finish the winner was eased up in 5:43.86 and the Lancia took the place handily. All three Paige cars finished.

Event No. 2 was for Class C cars of division 3, 231-300 cubic inches piston displacement at five miles. Five cars appeared on the starting line, two of the scratched cars being S. P. O. 14



1—Making the far turn in the first heat of the Remy Brassard race



2—How six thousand spectators viewed the Independence Day races

and Mercer 31, the drivers of which had met fatal accidents before the opening of the races. The Mercer contestant had the speed of the party and led from end to end, winning in the fast time of 4:55.51. Correja 8 was second all the way and S. P. O. 15 worked its way into third position at the end. The Schacht did not have its burst of speed and the Marion went out with tire trouble.

The "stable" got its first taste of glory in the next race which was for Class E cars, 301-450 cubic inches displacement. Two Nationals, a Benz and a Jackson formed the field. National 10 took up the pace in the early stages and appeared to have the foot of the party. But in the fourth mile the Benz came along under Patschke's handling and nipped the contender. The Benz went on to win handily in 4:42.47. The Jackson suffered with ignition trouble and was never prominent.

Simplex 2 had a nice easy run in the next number, winning from three Nationals and the Benz car that got the purse in the foregoing event.

The novelty race developed no novelties and not much of a race. The cars were required under the rules to load passengers at the end of the first mile, discharge them at the end of the second; load them at the third; discharge them at the fourth and finish without passengers. A Hudson car had too much speed for the Colby that contested against it. The Hudson won in 8:11.56, including the time lost in making the four stops and five standing starts.

Next came the first heat of the Remy brassard race at three miles, flying start, free-for-all. Five cars faced the starter, including the Blitzen Benz, plain Benz and Mercedes, from the



3—Line-up of the cars in Event No. 4, on the first day

Moross stable; National 33 of the Poertner Motor Car Company and Simplex 2 from the Simplex Automobile Company. After one false start, the cars came down to the line in a fairly good rank and the red flag signaled them to go. The plain Benz soon settled into a short lead, taking the pole position while out toward the center of the track the Blitzen lay second. In behind the leader, the Simplex ran along in third place, pocketed from wire to wire in such a way that, skillful driver though he is, De Palma could not get through. The others trailed throughout. The plain Benz finished first by a short margin with the Blitzen second and Simplex third. The time was 2:41.68.

Simplex number 20 was eligible to start in this event but the driver's card held by Ormsby had been suspended by the referee for the part the driver had taken in the accident that led to the death of H. Frey earlier in the day and the destruction of Mercer 32.

Event number 7 was changed from a one-hour race to a grind of 60 miles and drew out a fine field of eight starters. Simplex 2 won all the way without being extended. Second place went to Mercer 32, which worked its way up from fourth position. It was about 2 miles behind the winner and 1 1-2 miles ahead of Marion 13, which came third. The race was marked by a bit of sensational driving on the part of the pilot of Pope-Hartford 18. Disbrow blew a right rear tire making the paddock turn in the thirty-eighth mile and managed to bring the big machine to a stand just touching the fence after a plunging flight along the rail for over a furlong. The car was set going again in a short time and was a factor until the beginning of the final spurt, when tire trouble retired it.



4—The grandstand was not crowded on July 3

The trophy in this race was the W. B. and \$100 in gold.

The last event of the day produced an unusual mixup and an unusual ruling on the part of the officials. It was a free-for-all handicap in which 14 cars presented themselves for the start. The word was given to the three Paige-Detroits which were to receive the limit handicap and when the Paiges started, six other cars went along. At the end of the mile it looked very much like a jam but the net results were the loss of a wheel by one of the Paige cars. The referee then refused to allow any of the six cars that had taken part in the breakaway to compete. These were the Crow 5; Correja 8; Marion 13; S. P. O. 15; Lancia 16 and E-M-F 19.

The race proved rather easy for Mercer 32 with Simplex 20 second and Pope-Hartford 18 third. Time 5:33.53.

On July 4, the big Benz, under Burman's handling, lowered the dirt track record one-fifth of a second and won the Remy brassard by taking two successive heats from the plain Benz. Patschke, driving a dark horse known as the Jenatzy Mercedes, made one surprising spurt in this event and for a moment headed his colleagues on the far turn. The Jenatzy, however, was not up to much and flattened out after that single flash.

The card included a free-for-all handicap which was won by the E-M-F by the length of its hood from the fast coming Pope-Hartford. The brush through the stretch between these two cars was the closest and most terrific bit of driving of the afternoon. The handicap of the E-M-F was sufficient to give it a start of practically half a mile and as the pace was rather easy in the first two miles the Pope-Hartford had to come with keen speed to draw the finish so close.

The Correja won Class C, Division 3C, event with ease, finishing ahead of the Marion and Crow.

The Prince Henry Benz had a cake-walk in the fourth event, but National 33 defeated it and several others in the next class. Then came the foreclosure of the mortgage on the brassard as stated. National 33 won the Australian pursuit race after a fierce struggle. National 10 was put out first in this race by being passed by Simplex 20 and, in turn, National 33 put out the Simplex. This left only the Pope-Hartford and National 33 in the race and after a fierce drive of 23 miles the Pope blew a tire in front of the stand and in sight of 15,000 people the pilot racked the steering wheel in response to the reeling of the wounded car and brought it to a safe stop in front of the judge's stand.





5—Passengers scrambling into the Hudson, winner of the novelty race  
 6—Line-up for the 301-450 race on the first day—Benz, two Nationals and a Jackson  
 7—Start of the 60-mile race, which was won by the Simplex, Mercer second, Marion third  
 8—The E-M-F, Jack Tower driving, which won three races

A small class race was won by the E-M-F which was not on the program and was probably inserted to make up for the fact that most of the cars that took part had been barred from the free-for-all handicap of the previous day.

One of the most interesting races of the meeting was the last one carded for July 4. It was at 50 miles and brought out a field of six. Pope-Hartford won rather handily after the two Nationals had succumbed to tire trouble. The Jackson car was second and the Crow, carefully and conservatively driven by Otto F. Rost, General Eastern Agent of the company, was third. The Crow did not go to the pits for tires or anything else and was running considerably faster at the finish than earlier in the race. It was last to get away and maintained a steady pace all the way through and as one car after another went out from tire or motor troubles it forged toward the front. At the rate the last 10 miles were run, it would have won had the race been 60 miles long.

**JULY 2—FIRST DAY**

Division 2C for cars of 181-230 cubic inches, Five Miles.				
Number	Car	Driver	Position	Time
19	E-M-F	Tower	1	5:43.86
16	Lancia	Ferguson	2	
29	Paige-Detroit	Craig	3	
30	Paige-Detroit	Shannahan	4	
27	Paige-Detroit	Regan	5	
24	Regal	Tate		
12	Hudson	Mulligan		
Division 3C, 231-300 cubic inches, Five Miles.				
32	Mercer	Hughes	1	4:55.51
8	Correja	Forstur	2	
15	S. P. O.	Juhasz	3	
9	Schacht	Gray	4	
13	Marion	Anderson	5	
Class E, 301-450 cubic inches, Five Miles.				
4	Benz	Patschke	1	4:42.47
10	National	Sheets	2	
26	National	Knipper	3	
34	Jackson	Cobe	4	
Class E, under 600 cubic inches, Five Miles.				
2	Simplex	De Palma	1	4:45.93
33	National	Zengel	2	
10	National	Sheets	3	
4	Benz	Patschke	4	
26	National	Knipper	5	

Novety Race, Five Miles				
Number	Car	Driver	Position	Time
7	Hudson	Lame	1	8:11.56
35	Colby	Tyrock	2	
Class D, Remy brassard. First Heat, Three Miles, Flying Start.				
28	Benz	Knipper	1	2:41.68
1	Benz	Burman	2	
2	Simplex	De Palma	3	
33	National	Zengel	4	
3	Mercedes	Teizlaff	5	
Class E, under 600 cubic inches, Sixty Miles, for W. B. Trophy.				
2	Simplex	De Palma	1	59:21.37
32	Mercer	Hughes	2	
13	Marion	Anderson	3	
Class D, Free-for-All Handicap, Five Miles.				
32	Mercer	Hughes	1	5:33.53
32	Simplex	Lund	2	
18	Pope-Hartford	Disbrow	3	

**JULY 4—SECOND DAY.**

Class D, Free-for-all Handicap, Five Miles.				
Number	Car	Driver	Position	Time
19	E-M-F	Tower	1	5:39.77
18	Pope-Hartford	Disbrow	2	
29	Paige-Detroit	Craig	3	
Division 3C, 231-300 cubic inches, Five Miles.				
8	Correja	Forstur	1	5:33.81
13	Marion	Anderson	2	
5	Crow	Rost	3	
15	S. P. O.	Juhasz	4	
Class E, 301-450 cubic inches, Five Miles.				
4	Benz	Patschke	1	4:43.39
18	Pope-Hartford	Disbrow	2	
26	National	Knipper	3	
Class E, under 600 cubic inches, Ten Miles.				
33	National	Zengel	1	9:16.81
10	National	Sheets	2	
18	Pope-Hartford	Disbrow	3	
Class D, Three Miles. Second Heat, Remy contest.				
1	Benz	Burman	1	2:37.38
28	Benz	Knipper	2	
3	Mercedes	Patschke	3	
Final Heat.				
1	Benz	Burman	1	2:56.08
28	Benz	Knipper	2	
3	Mercedes	Patschke	3	

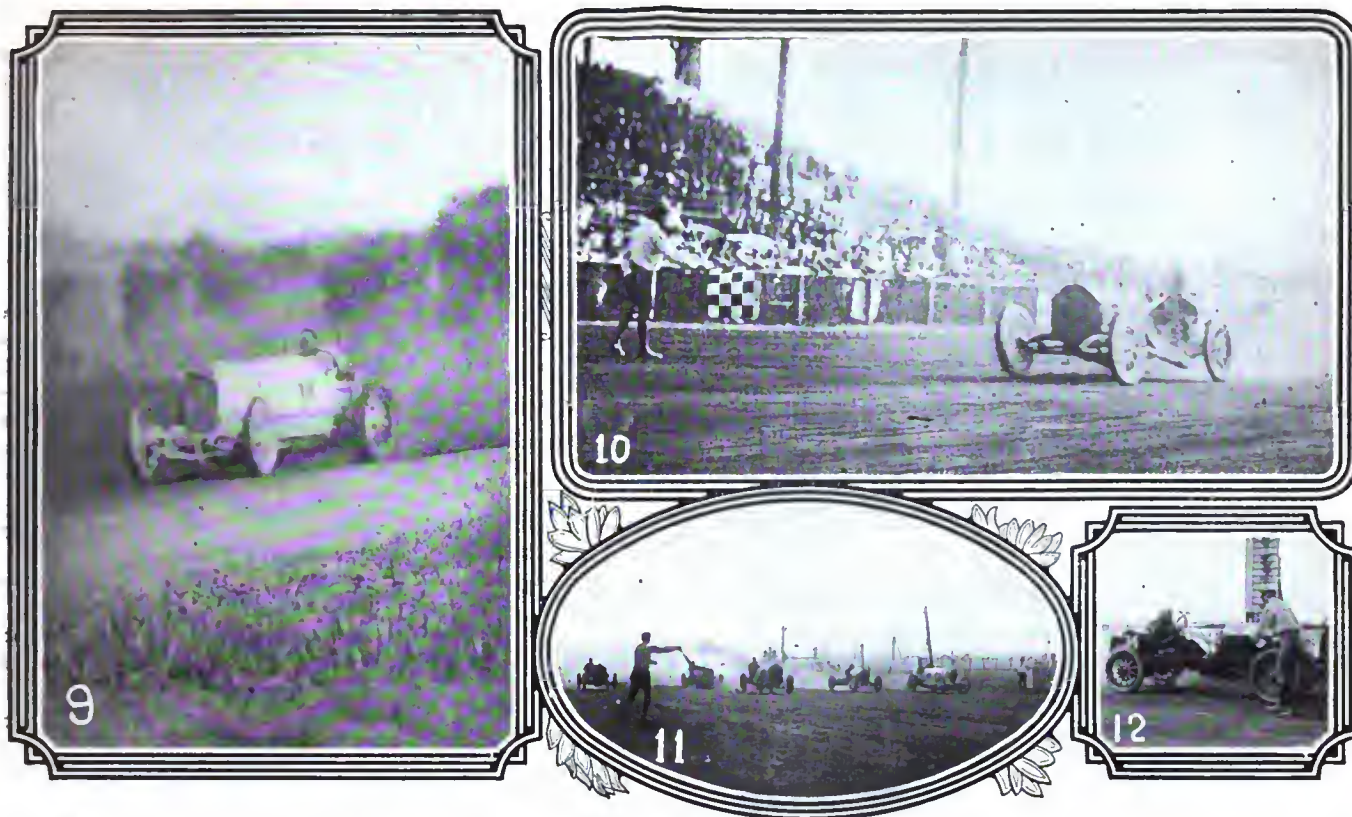

9—Burman in the Blitzen Benz breaking the track record  
 10—The Simplex, which won the 60-mile event on the first day  
 11—Flying start of the contestants for the Remy Brassard  
 12—Harry Cohe in the Jackson, which finished second in the 50-mile event

Class D, Free-for-all Australian Pursuit Race.			
33	National	Zengel	1
18	Pope-Hartford	Dishrow	2
20	Simplex	Lund	3
10	National	Sheets	4
Class E, 600 cubic inches and under, Fifty Miles.			
18	Pope-Hartford	Disbrow	1
34	Jackson	Cobe	2
5	Crow	Rost	3
One Mile Time Trial.			
1	Benz	Burman	48.72
Division C, 161-230 cubic inches, Five Miles.			
19	E-M-F	Tower	1
29	Paige	Craig	2
30	Paige	Shannahan	3
24	Regal	Tate	4

### New Electric in the Field

LOUISVILLE, July 3—The Electric Vehicle Company, which will manufacture electric trucks, has opened its new plant at Preston and College streets. Later the concern will build electric pleasure cars. The new plant, which is the first in Kentucky to manufacture electric cars, covers 20,000 square feet of floor space. All of the machinery has been installed and the capacity of the plant at present will be about 100 cars each year. Those interested in the new company are Lee Miles, of the Miles Auto Company, E. M. Drummond and H. B. Hewitt, who has been connected with the Cooper-Hewitt Company.

A panel-delivery standard body, with other types optional, will be used on both the 600 and 1,000-pound vehicles. The silent chain drive has been adopted. A wheel base of eighty-six inches is used. Fully loaded the trucks are capable of traveling from 12 to 15 miles per hour.

### Will Handle American and Marion

Papers have been filed in Albany for the incorporation of the American-Marion Sales Company, a \$100,000 corporation to handle the American and Marion cars in the Metropolitan district. The incorporators are: James I. Handley (formerly vice-president of the U. S. Motors), Chas. E. Riess, distributor of the Marion cars, and Geo. R. Morris, at present general manager for Chas. E. Riess & Co.

### Missouri Licenses to Come Down

St. Louis, July 3—A general reduction of the price of automobile licenses is in prospect for St. Louis. A law passed by the last legislature regulating the State charge makes it incumbent on cities to charge no more than is authorized under the State law. For years the rate in St. Louis has been \$10 for each car, regardless of the size, type or horsepower. Under the new law the average charge will be about \$5. There have been 4,632 licenses issued in St. Louis so far this year.

The new law goes into effect Aug. 1. The city's lawmakers are expected to pass a new ordinance covering the situation before that date.

### Premier Caravan on Westward Way

INDIANAPOLIS, IND., July 5—After two days of feasting and sight-seeing in Indianapolis the sturdy Ocean-to-Ocean Premier tourists again turned their faces westward this morning. The first 1,000 miles of the long journey, from Atlantic City to Indianapolis, were accomplished with no more wear or tear or mishaps than are generally encountered. The big party of Philadelphia and New York business men, with their families and friends filling eleven cars, were as enthusiastic as children just out of school and all were confident that the tour would be a success.

The Northern route across the Great American desert will be followed, Chicago being the next stop on the schedule after the departure from Indianapolis. From Chicago the route lies through Des Moines, Ia., Omaha, Denver, Cheyenne, Salt Lake City, Reno, San José, San Francisco, Santa Barbara and Los Angeles. The tourists are due to arrive at the latter place September 10.

## Seen in the Show Window

**K**NOWING a situation is equivalent to being able to describe it, and controlling the powers of nature includes not only their utilization, but also the possibility of measuring their amounts and intensities. This being true and applied to that most popular energy, electricity, it is seen that the many ways in which it is utilized to-day have brought about the construction of almost as many sorts of instruments of measuring and controlling that force, the fundamental of these appliances being voltmeters and ammeters. Since automobiles, at the present time, use considerable quantities of electricity, for propelling cars, igniting a mixture and illuminating the machines at night, it was only natural that special types of instruments for measuring the energy used in the work of charging automobile batteries were constructed. One of the up-to-date results of these efforts is illustrated at (AK), this being the volt and ammeter of the Weston Electrical Instrument Company, whose factory is at Newark, N. J.

**T**O increase the driver's efficiency as well as his good disposition is a proposition which cannot but interest the gentleman automobile owner, and the little step in the forward direction which will bring him to the end desired is the acquisition of an electric lamp ignitor, an example of which, the Hart Instantaneous Gas Lamp Ignitor, is shown at (AM). By means of this device the driver, after opening the way for the acetylene to the headlights, ignites the gas without leaving his seat, by the simple expedient of pressing a button or turning a key, whereby a circuit is closed and a battery in conjunction with a sparking coil produces a spark above the acetylene burner, which is sufficient to instantly ignite the gas. This igniter is made by the Hart Gas Light Igniter Company, of Hartford, Conn.

**T**HERE are occasions where the cut-out comes in handy, as in starting up a hill, and the silencing effect of the muffler will have to be sacrificed at such times for the utilization of what otherwise makes itself felt as back pressure. The S. B. R. Muffler Cut-out is illustrated at (AL), and being of simple construction, it is easily installed on a car in the minimum of time. The cut-out valve seen at the lower portion of the device, and which has a ground seat with spring holder, is operated from the dash by a pedal in the usual manner. This appliance is the product of the S. B. R. Specialty Company, of East Orange, N. J.

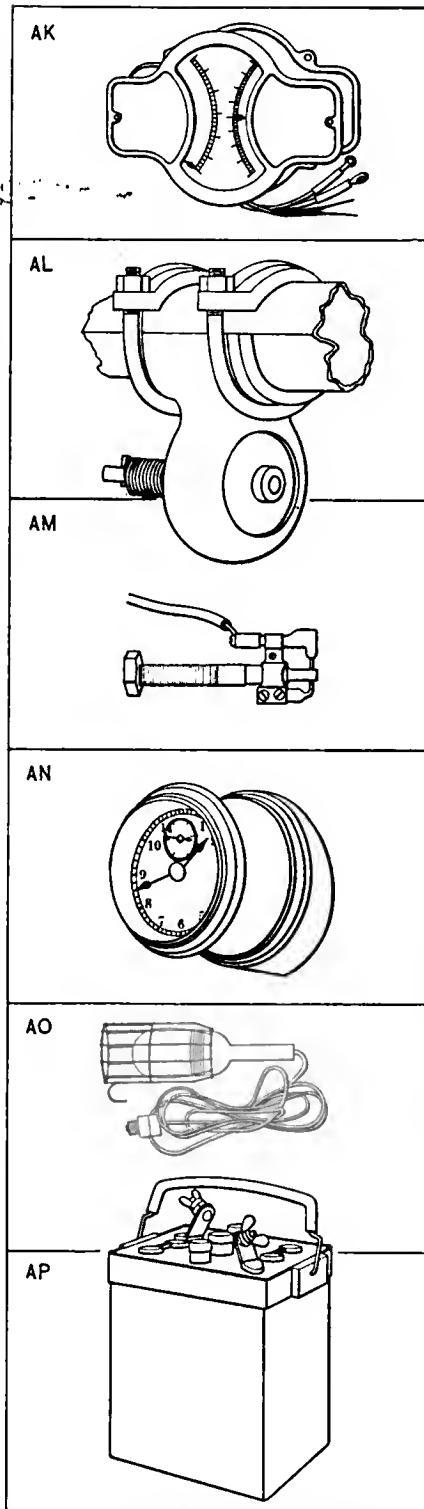

AK—Type of volt-ammeter for various uses in connection with automobiles  
 AL—Illustrating one of the latest types of muffler cut-outs  
 AM—Enables the driver to light his lamps without leaving the seat  
 AN—Keyless dash clock which will prove a convenience for automobilists  
 AO—The Morse special type of portable electric lamp for garages  
 AP—Outward appearance of the Geiszler storage battery

**S**TORAGE batteries are used on automobiles for several purposes, and, judging from present tendencies, the number of their applications in this field seems to be still on the increase. Compactness and efficiency, together with a relatively high capacity, are the main features looked for in batteries, but there are also some points of chemical rather than physical nature, these being the degree of sulphation that the various types of accumulators are subject to. The Geiszler storage battery, an illustration of which is here afforded (AP), is claimed by its makers to be non-sulphating, and the manufacturers guarantee that the battery will not deteriorate while it stands idle. It is manufactured by the Geiszler Bros. Storage Battery Company, whose address is 1512 W. Fifty-seventh street, New York.

**T**OO many accessories crowded on the dash may be a nuisance, but just because this is so it will be necessary for the autoist to weigh out carefully the importance of all the various devices which may be placed there, before deciding to eliminate some of them therefrom. Every motorist will grant that having the right time before him is a very desirable state of affairs, because a clock on the dash will never be considered a nuisance if compared to the timepiece which is carried in one's pocket and is hard to get at when driving. The Perfect Auto Clock, which has a Seth Thomas movement contained in its makeup, is shown at (AN), a special feature of this clock being that it is not wound up by means of a key, but the bezel is turned around once a week. This strong little piece of machinery is made by the Phinney-Walker Keyless Clock Co., of 77 E. 130th street, New York.

**E**LECTRIC light must necessarily be used all over in garages, and it is found in the important regions of these establishments; but the employees are not very frequently equipped with portable lights permitting of looking over any parts of a car without using any other illumination but an electric bulb. A special type of garage lamp is made and sold by Frank W. Morse of 516 Atlantic avenue, Boston, Mass., the lamp being shown at (AO). It consists of a vapor-proof globe containing a 16-candlepower lamp, a waterproof socket in handle, silvered guard and reflector, together with 12 feet of slicked cord and a two-piece plug. A special feature of this lamp is its being perfectly proof against combustible vapors.



# THE AUTOMOBILE

## What Motor Inventors Are Doing Quest for Silence in Devious Ways

*Following the introduction of the Knight type of sleeve motor in America there are many indications of activity along more or less similar lines, and inventors are taking advantage of the rotary principle of valve mechanisms to some extent and to sliding valves in various forms, and the illustrations here afforded are contributed by one school of design in the quest for silence and efficiency.*

**W**HEN the sleeve type of motor was first presented to the notice of the builders of automobiles it fell upon deaf ears. It was not then supposed that a machine could be built so that it would perform silently, and in all fairness noise was courted on the ground that it was a good indication of a vigorous power plant. As time settled upon the ability of power plants in general, and it was learned that noise was not necessarily an indication of power—in fine, when efficiency became a factor in the enterprise and the twins of merit were looked upon as the progeny of silence, and efficiency—the desire to get away from the causes of noise and power losses took root in the thoughts of designers; the automobile industry has so far progressed that the supporters of the industry are putting a premium on silence, and it would be difficult to disabuse them of the idea that where silence reigns efficiency is absent.

It would be difficult to state how many of the makers of automobiles of to-day are working upon the various types of



IN THE COMPETITION FOR SILENCE

motors that do not depend upon poppet valves for their performance. Moreover, it may be truly stated that every maker of cars who puts faith in poppet valve mechanisms is re-designing the parts on a basis of silence as the prime consideration, and it is doubtless true that when the valves do their work noiselessly they function efficiently also. It is more than likely that the best testing instrument available to the mechanic may be known by the appellation of "kinetic silence," the attempt being made here to

distinguish between the static and the kinetic condition, with the hope, perchance, that the silence of the machine as it rests in its motionless static state will be transferred to the time when the motor is doing kinetic work.

There are many schools of design in motor building, and the staunch advocates of the poppet valve type of motor are proving by their work that silent performance is no stranger to a well-made poppet valve type of motor, nor is there any indication at the present time that these sturdy power equipments are to be supplanted by something new. It has been said in recounting business ventures in general that upwards of 94 per cent. of all the efforts that are made end in failure, and that a sparse 6 per cent. of industrial activity ends in success. Of the many undertakings in the motor field that have for their foundation the building of something new, it is not too much to expect that the customary percentage of the whole effort will go down in history on the carry-all of failure, and it is the purpose in this presentation to save time and the sap of investment by telling the various designers of the efforts that are being made in this field, avoiding, in so far as it is possible to do so, the praising of individual undertakings until it can be shown by actual trial that they will survive the "acid" test.

### How the Various Designers Approach the Difficult Problem of Motor Building

Before passing on to the discussion of the types of motors that differ in principle from the Knight design, it is proposed to show by illustration and reference the modifications of this idea as they

obtain in Continental makes of motors, and Fig. B is an elevation in part section of the Panhard-Knight motor as made by Panhard & Levassor, Paris. In this elevation, which is of the left-hand side of the motor, the front cylinder is given in section, showing the main bearings  $M_1$ ,  $M_2$ , and part of the middle main bearing  $M_3$ , the latter being provided with means for taking the thrust imposed upon the crankshaft. The connecting rod  $C_1$  has a liberal size of large end bearing  $M_4$ , and the piston  $H$  has three rings  $h$  above the gudgeon pin. Attention is called to the inverted sphere-like head of the piston, and the fact that one of the piston rings  $h$  is in the body of metal forming the wall of the piston above the plane of the inverted sphere-like head. Among other possibilities it is more than likely that the designer of this motor figured upon the insulating quality of a layer of dead gas in the cup formed in the piston head, but this depression is also indicated

period of combustion. In this particular design of motor a single spark plug is inserted in the axis of the head, but the provision for cooling in the region of the spark plug is on a liberal basis.

The eccentric shaft  $L$  takes its power from the crankshaft through the pinion from the crankshaft through the pinion  $K$  by means of a silent chain to the gear  $K$ . The sleeves  $N$  and  $N'$  have motion imparted to them through the connecting rods  $M$  and  $M'$ . The shrouded pulley  $V$  on the end of the crankshaft takes a belt for use in driving the air propeller. The crankshaft is flanged at the rear end and the main bearing  $M_5$  is of unusual length and has a liberal projected area.

Referring to Fig. C of the Panhard-Knight motor, the contour of the inlet and exhaust ports is sweeping and smooth, terminating in symmetrical lips of the inlet and exhaust ports, and when the piston  $H$  is on the top dwell point, the space between the shell of the piston head and the inmost point of the cylinder

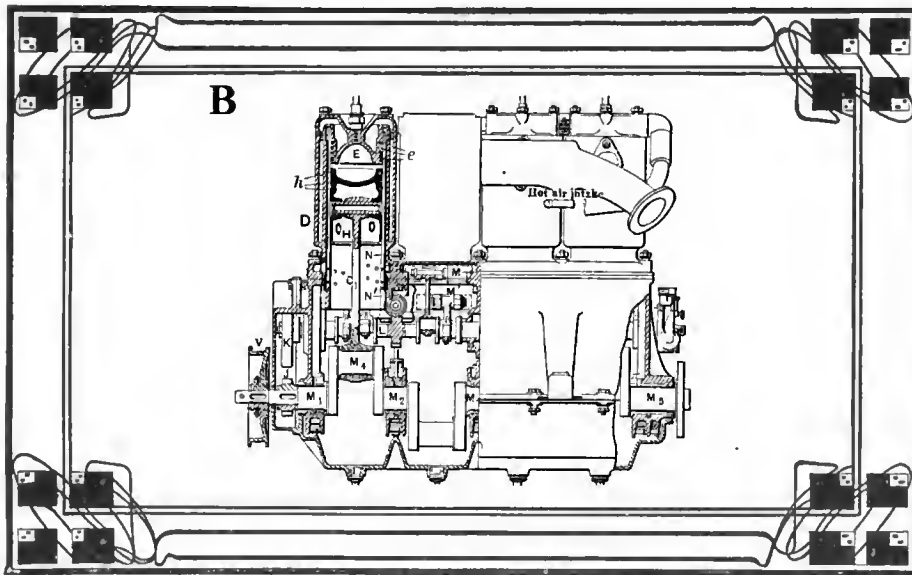

Fig. B—Sectional view of the Panhard-Knight motor, showing the relation of the sleeves, the spherical piston, and the method of operating sleeves

by the necessities of a proper compression ratio dictated by the fact that the cylinder head inserts into the cylinder and a considerable amount of the diametral space is occupied by the walls of the head, accommodating a junk ring  $e$ , not forgetting that the sleeves are in the concentric relation with the cylinder, also the piston, and the part of the head that extends down into the cylinder, so that the compression space  $E$  formed in the head would scarcely suffice in view of the requirement, and it therefore follows that the depression of the piston head offers the advantage of regulating the compression ratio without the necessity of exposing the walls of the sleeves to the flame during the period of combustion. We do not call to mind that anyone has heretofore pointed out that the sleeves of the Knight motor are protected from the fierce glare of the flame during the

head is barely sufficient to uncover the slots in the sleeves, and the packing rings  $n_1$  and  $n_2$  on the inlet side, co-operating with the slots in the region of the exhaust port, imprison the mixture under compression within right confines, and leakage is substantially avoided. In examining this section of the cylinder in the region of the lips of the ports we do not find the same careful attempt to maintain cool conditions as is shown in some of the other examples of this same make of motor, although the excess of metal forming the lips of the ports is in close relation to the water in the jacket, the difference being due to the extension of the lips for an unwatered distance, and the bunching of metal, due to fillets, that must obtain under foundry conditions in a design so made. The carbureter is located on the right side of the motor and the intake  $I$  is of somewhat symmetrical

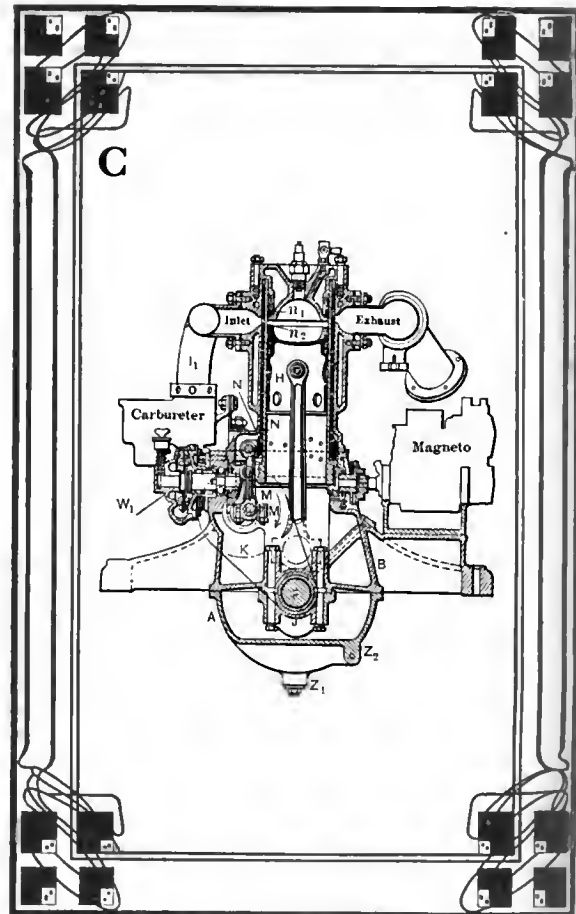

Fig. C—Transverse section of the Panhard-Knight motor, showing the small connecting rods that operate the sleeves and the cup-shaped piston

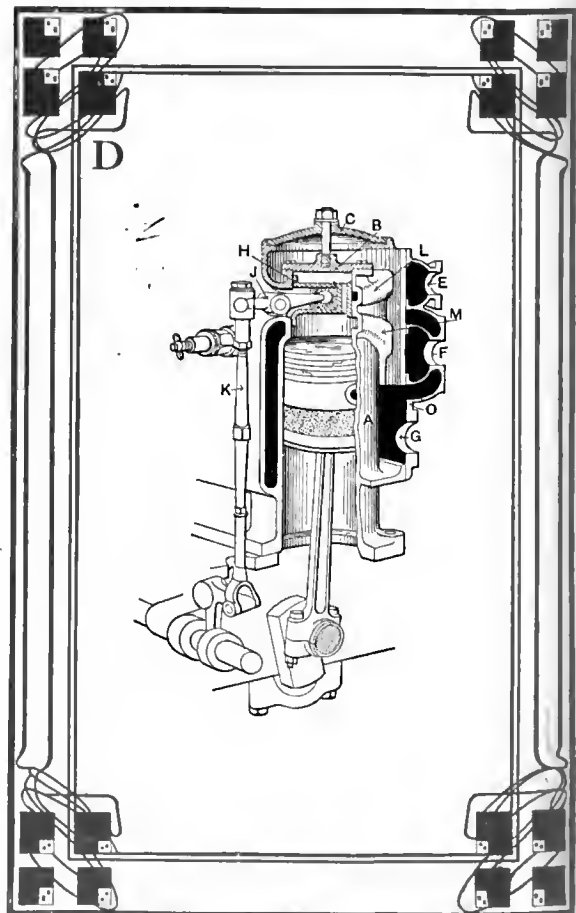

Fig. D—Showing the Reno Bois motor with part of the water jacket removed, together with the valve operating mechanism.



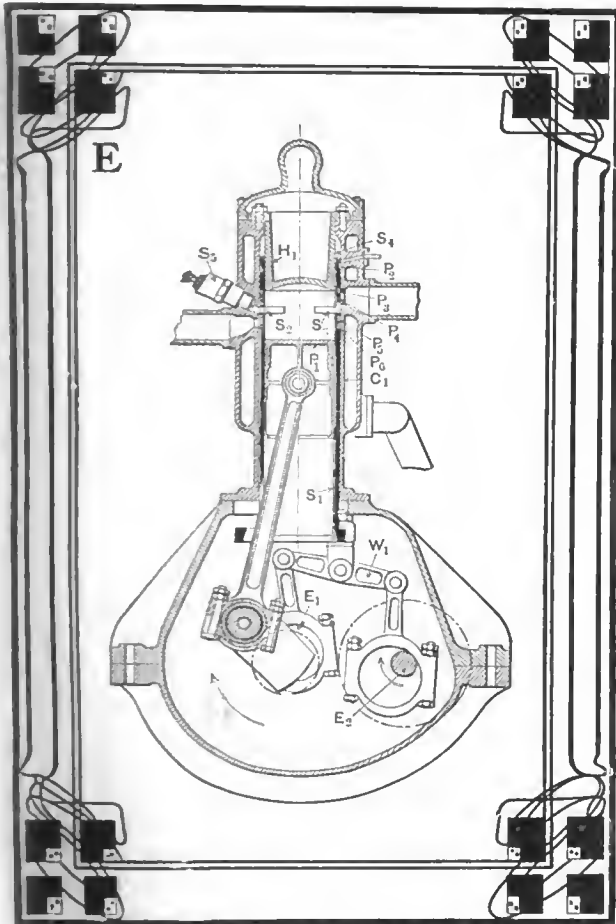

Fig. E—Transverse section of the Rolland & Pillain motor, showing the method of operating the single sleeve and the location of the spark plugs

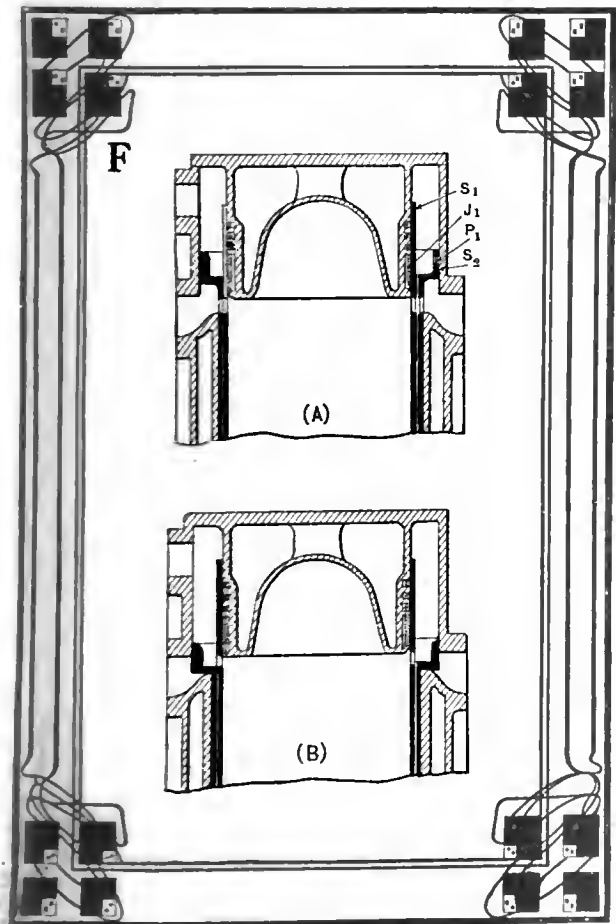

Fig. F—A shows section of motor with sleeves open. B shows position of outer sleeve when valves are closed

design, with an upward trend for a material distance before it branches out through the distributing arms to the respective cylinders. The magneto is on the opposite side of the motor, taking its drive from a cross shaft, the latter being driven through the good office of a spiral gear located between the first and the second cylinders on the eccentric shaft.

The water pump W1 is shown in section on the right hand side of the motor and is driven by an extension of the cross shaft in the plane of the magneto drive; an Oldham joint is placed in the length of this shaft at the approach of the water pump. Referring to the joint in the shaft as it extends to the magneto, it is of the dog type, and the magneto resting on a ledge extending out from the crankcase may be unbolted and removed at will without having to undo the joint, thus making for easy examination and repair.

faced or channeled cam carried on a camshaft parallel with the crankshaft.

To allow the rocking lever J to pass into the cylinder a slot is provided in the latter, which is always covered by an extension of the ring valves whatever the valve position. The split ring valve in its travel moves over the annular chambers L and M, which are cast in the cylinder wall and form the inlet and exhaust ports respectively, these ports being in communication with the inlet or exhaust trunks E and F.

The diagrams (a) (b) (c) and (d) in Fig. G show the valve in the induction, compression, firing and exhaust positions, the inlet port E (Fig. D) and the exhaust port F being shown uncovered during the induction and exhaust strokes, and both covered during the compression and working strokes. A (Fig. D) is the cylinder casting with a detachable head B, the central bolt of which holds the water jacket cover C. The side plate D carries

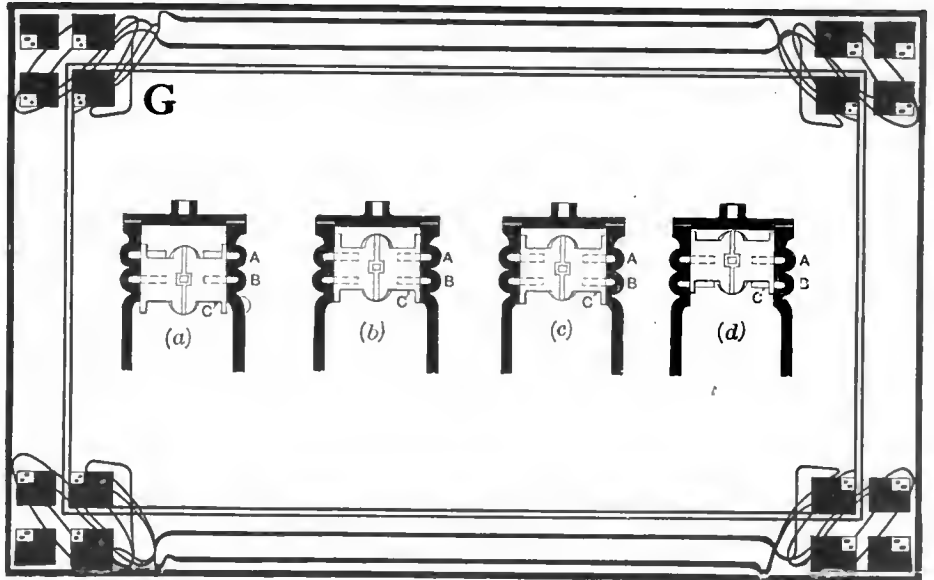

Fig. G—Section of the Reno slide valve engine showing induction, compression, firing and exhaust strokes respectively

### How the Reno Bois Place the Sleeves in the Cylinder Head

Fig. D, which is a part section through the cylinder of the Reno motor, is a clear presentation of the idea instilled in this design, showing the crankshaft in the crankcase in the customary way and the connecting rod joining the crankpin to the piston through the gudgeon in the regular way, the valve mechanism being placed in the cylinder head, which by letter reference is described thus: The valve gear consists of a split ring H fitting closely in the cylinder head and provided with a bearing block which is engaged by the rocking lever J, which in turn is operated by the tappet K. This tappet is raised and lowered by means of a short bell crank, one leg of which engages the tappet, and the other a double-

the inlet union and chest E, and the exhaust trunk and union F, also the water connection G. The report of the performance of a motor of this design with a bore of 85 millimeters and a stroke of 130 millimeters states that the motor delivers 28 horsepower at 1,350 revolutions per minute, and it has been stated that this is the speed of greatest stability, although the motor accelerated during the test up to 2,200 revolutions per minute.

### Rolland & Pillain Single-Sleeve Motor

A motor that performed favorably under racing conditions in France within the last two or three months, the Rolland & Pillain, is shown in Fig. E with the sleeve S1 concentrically related to the cylinder C1 and the piston P1 with slots S2 and S3 in the sleeve and a depressed head H1, leaving a space S4 between the

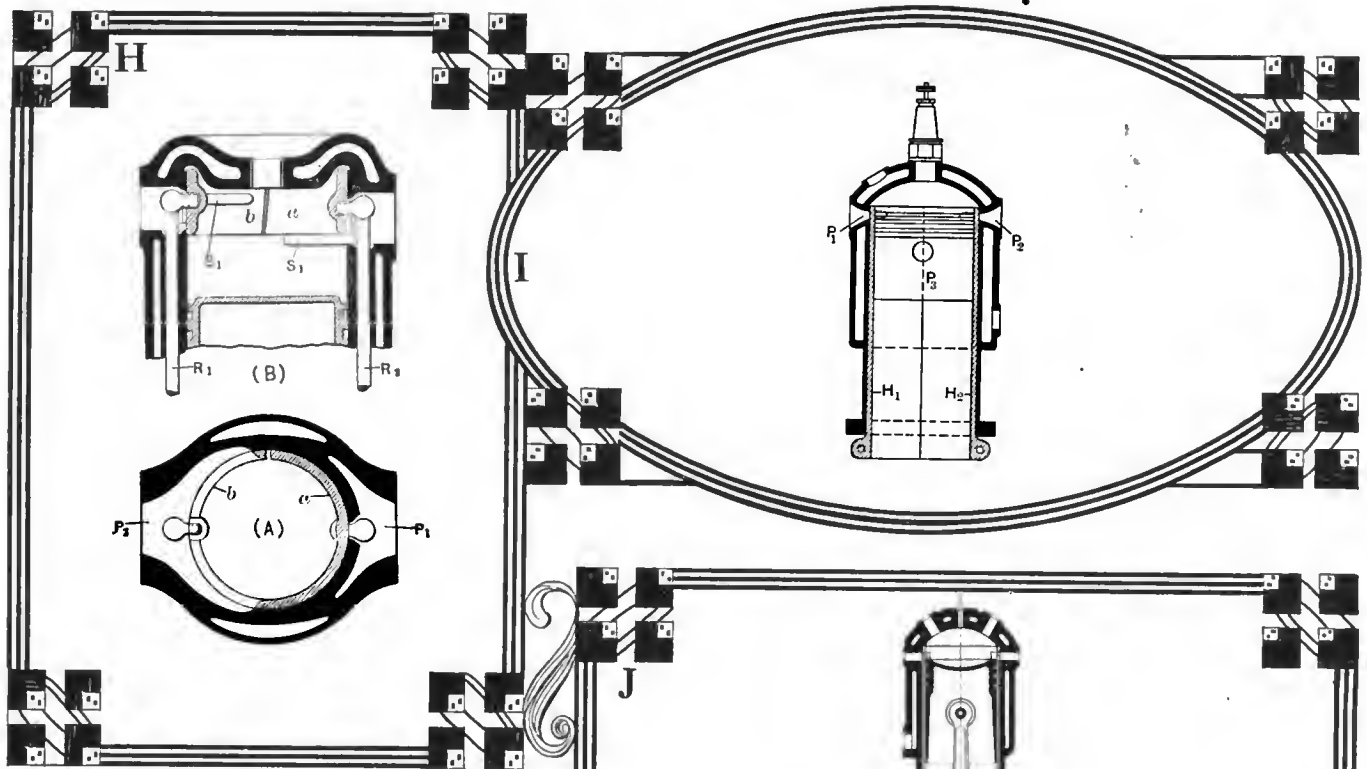

Fig. H—Sectional view of the Howard sliding sleeve valve motor utilizing a spherical split ring

cylinder wall and the head to accommodate the sleeve in its reciprocating relation, with packing rings P2, P3, P4, P5 and P6, in the sleeve to maintain good compression, and the spark plug S5 so located that firing must take place during the period of uncovering due to the slot in the sleeve, shutting off the spark when the port closes. The sleeve S1 is given reciprocating motion by the walking beam W1, which is actuated through a combined effort of the eccentric E1 on the crankshaft and the eccentric E2 on the half-time eccentric shaft. The water-jacketing of the motor has been done with care, and the general design shows the earmarks of a motor engineer.

**Knight Makes Modification of His Main Type of Motor**

In *Der Motorwagen* of November 30, 1910, there was a description of the modified forms of sleeves as shown in Fig. S at A and B. Referring to A, the junk ring J1 aided by the three rings above are placed to maintain the tight relation of the long sleeve S1. The short sleeve S2 is so fashioned as to press against the outer wall in the cylinder head above the ports and a packing ring P1 is placed in the enlarged diameter of the ring to prevent the leakage of compression. In B, Fig. F, the outer ring is in the down position covering the ports.

**Showing the Construction of the Howard Motor**

In the Howard motor, which is given in sections A and B, Fig. H, the crank-

shaft, connecting rods and pistons conform to the conventions. The valve mechanism is composed of horseshoe-like members a and b in the head above the piston on the top of the stroke, with slots S1 and S2, which are covered and uncovered according to the four-cycle principle, and a reciprocating motion that is required for the purpose is imparted to the covers by means of the rods R1 and R2, as shown in the section B.

Referring to the section A through the cylinder and valve covers, the cover a is over the port P1, but the cover d is in the position of "open," permitting the flow of gas from the port P2. A further examination of this type of valve mechanism places it in the class with the Reno motor, and the sliding members forming the valves are held to their seats by pressure.

**Referring to the Redrup Type of Sleeve Motor**

Fig. I is a section through a cylinder of the Redrup type of sleeve motor show-

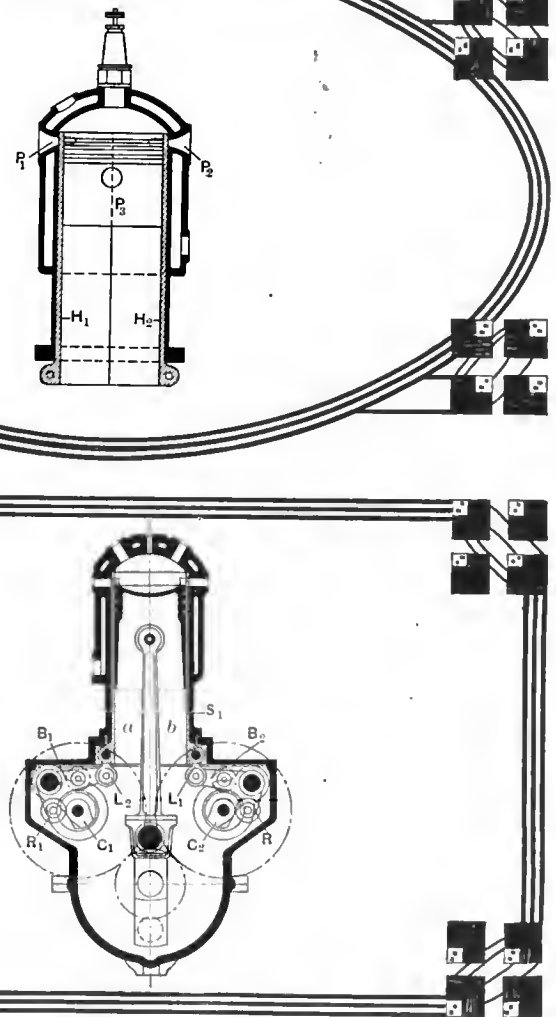

Fig. I—Transverse sectional view of the Redrup motor in which two hemispherical sleeves cover and uncover the valve ports

Fig. J—Transverse section of the Mustard motor, showing how the two hemispherical sleeves are operated by means of cams and rollers

ing a single sleeve between the piston and the bore of the cylinder, the main difference being that the sleeve is in two halves H1 and H2, split through the diameter as indicated by the line a, and the two halves of the sleeve are given reciprocating motion to cover and uncover the ports in the four-cycle timing relation. In the patent specifications of this motor the sleeve members are described as follows: "Consisting of a tapered sleeve split in halves lengthwise and fitted inside a cylinder which has one end closed to form the combustion chamber. The slides are at the inner end of their travel (as shown) so as to cover the ports B1 and B2; the slides would remain in this position during the compression and power stroke of the piston P3, which reciprocates within the parallel bore of the sleeves H1 and H2. Owing to the outside of the sleeves and the inside of the cylinder being slightly tapered, when the slides are in the position shown, pressure will be exerted on their meeting faces along two diametrically opposite division lines, thus making these two joints tight,

and also making a tight joint by each sleeve over the two ports, and also between the sides of the slides and the piston. The inner ends of the slides are their thin ends, and the outer ends are the thick ends, while the bore of the cylinder is smaller at the inner end and larger at the outer end." The invention provides for the linking up of the slides in any suitable way.

**O. Mustard Comes Out with a Modification of the Idea Described in Fig. J**

During the last Paris Salon interest was taken in the design of motor as shown in Fig. J, which is a section through the same, presenting a sleeve S<sub>1</sub> in the bore of the cylinder accommodating the piston, the sleeve being in two halves a and b, split longitudinally. Motion is imparted independently to the respective halves of the sleeve to give the four-cycle timing. This sleeve motion is induced by cams C<sub>1</sub> and C<sub>2</sub> on opposite sides of the crankshaft and is interpreted by rollers R<sub>1</sub> and R<sub>2</sub> through a bell crank B<sub>1</sub> and B<sub>2</sub>, thence to linkages L<sub>1</sub> and L<sub>2</sub>.

The camshafts are in the halftime relation with the crankshaft.

**W. W. Moore Resorts to the Use of a Single Sleeve**

Referring to Fig. K, showing a cross-section of a cylinder of a motor, the single sleeve A is in the concentric relation with the piston in the bore of the cylinder, and the ports b and c are uncovered according to the four-cycle principle of timing, reciprocating motion being given to the sleeve through the links d interpreted by the lever e with a fulcrum at f and a cam motion g. In other respects this type of motor conforms to the main idea of sleeve design.

**Chalmers Takes Kindly to the Two-Sleeve Idea**

Fig. Q presents a Chalmers motor of the double-sleeve type in part section, the sleeves being of different lengths with a long sleeve L<sub>1</sub> within and a short sleeve S<sub>1</sub> between the long sleeve and the bore of the cylinder B<sub>1</sub>. Motion is imparted to the sleeves through the link L<sub>2</sub> for the long sleeve, and the link L<sub>3</sub> for the

short sleeve from an eccentric E<sub>1</sub>, taking rotary motion from the crankshaft S<sub>2</sub>, the speed of the eccentric being half of the speed of the crankshaft. A is the inlet port and B<sub>2</sub> is the exhaust port. The invention has been described as consisting in supplying air under pressure for scavenging and adding to the inlet charge. The air is admitted into the crank chamber by the passage C<sub>1</sub> and compressed on the down stroke of the piston. The compressed air then finds its way by the passage D<sub>1</sub> through the port E<sub>2</sub> which at the right time registers with the port F<sub>1</sub>. In this way the air compressed in the crank chamber is allowed to enter the cylinder twice during each cycle. This occurs at the end of the suction stroke after the inlet valve is closed. Thus the gas in the cylinder is added to by the amount of compressed charge supplied, and to compensate for the dilution the gas taken through the inlet port A is richer than usual. On the exhaust stroke fresh air is again admitted under pressure. In this case it affects the scavenging action.

**D'Orsay McCall White Type of Motor**

This motor is of the double-sleeve type, but instead of placing the sleeves within the bore of the cylinder in the concentric relation with the piston, they are placed between the outer wall of the water jacket and a protecting exterior sheath. The sleeve S<sub>1</sub> is given reciprocating motion through the connecting rod C<sub>1</sub>, assisted by a guide G<sub>1</sub>, and the sleeve S<sub>2</sub>

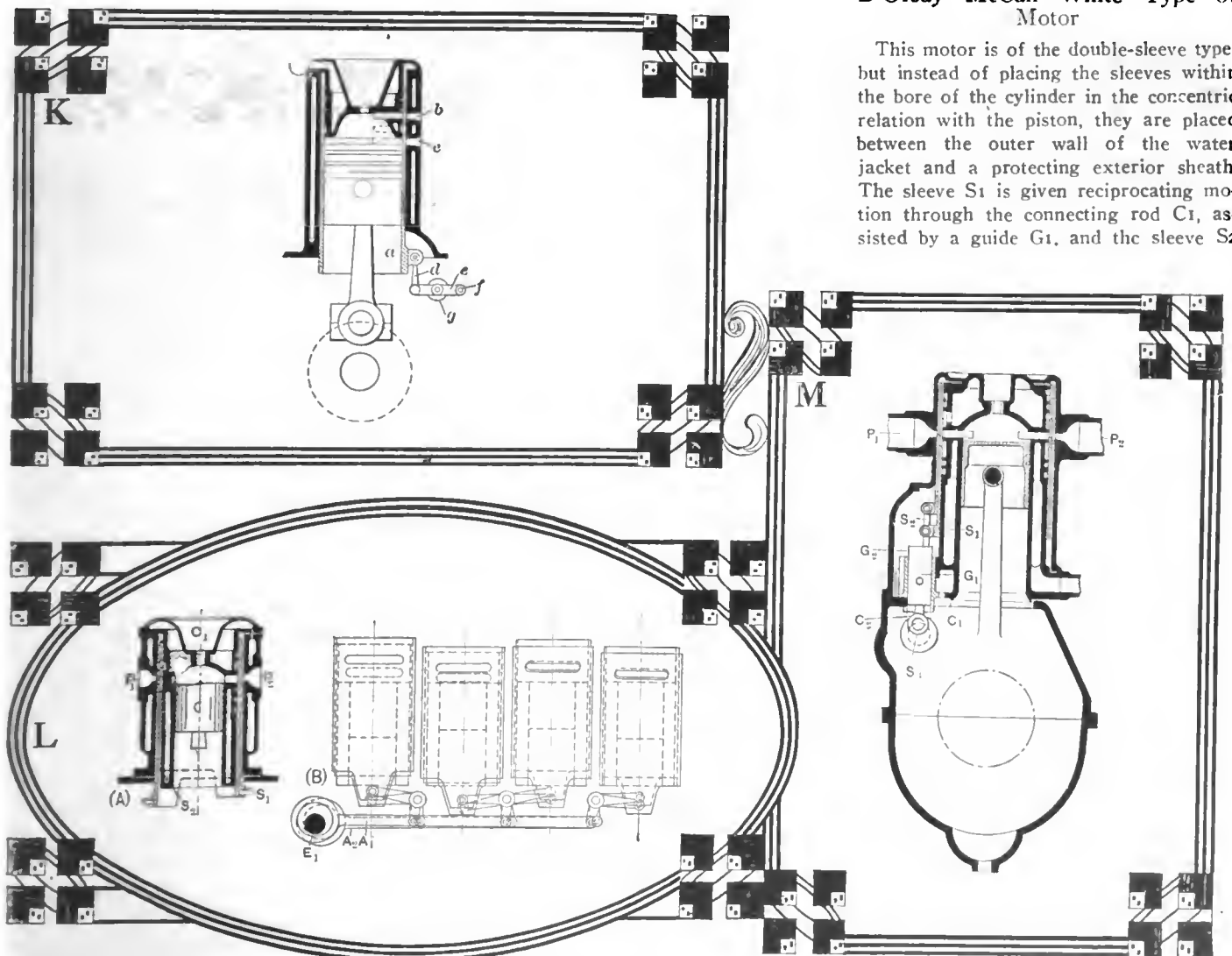

Fig. K—Section of Moore motor, using single sleeve, with slots one above the other  
Fig. L—A, sectional view of the Riley sleeve motor. B, valve operating mechanism of the motor showing the relation of the ports in the sleeves

Fig. M—Section of the D'Orsay McCall White Motor, showing the stationary valve guide situated inside and endwise-movable tubular distribution valve

is reciprocated by the connecting rod C2 through a companion guide G2. The connecting rods have motion imparted to them by eccentrics on the shaft S3. This shaft is driven through a train of gears by the crankshaft in the usual way. Gas is admitted through the port P1 and exhaust is out of the port P2. The slots in the sleeves register in a manner conforming to the four-cycle relations and leakage by the sleeves is prevented by rings in grooves suitably disposed in the exterior walls of the water jacket, assuring tightness under all conditions.

**Lanchester Motor of the Two-Sleeve Type**

Referring to Fig. N. of the Lanchester motor with two sleeves S1 adjacent to the piston in the concentric relation and S2 between S1 and the cylinder C1. The mode of operation imparting reciprocating motion to the sleeves is through a connecting rod C2 for the inner sleeve and another connecting rod C3 for the outer sleeve.

Reciprocating motion is imparted to the inner sleeve S1 through the connecting rod C2 by the eccentric E1 on the shaft S3, and motion is imparted to the sleeve S2 through the connecting rod C3 by the eccentric E2 on the shaft S4. The

ports P1 and P2 are covered and uncovered according to the four-stroke cycle principle. The cylinder head H1 is water jacketed and it is inserted into the bore of the cylinder which terminates in a spherical dome.

The shaft S4 by which the outer sleeve is driven, is mounted coaxially with the cylinder container, or may be arranged independently, so that the position of the shaft and the motion of the outer sleeve are unaffected by movements of the lever L1. The shaft S3 on the other hand receives motion of two kinds when the lever L2 is operated; it is displaced bodily parallel to itself in such a manner that the duration of the period during which the inner sleeve ports are uncovered with respect to the cylinder head is varied, the timing of mean position of the dead center being substantially unaffected by this component of the motion, but it receives a rotary motion due to the epicyclic action of the gears whereby the timing of mean position of the sleeve is also caused to vary.

**McIntosh Sleeve Type of Motor Has an Overhead Mechanism**

Referring to Figs. O and P of sections through one of the cylinders in two planes, the sleeves are given reciprocating

motion from an eccentric shaft E1 mounted on the top of the cylinder through links L1 for the sleeve S1 and L2 for the sleeve S2. According to British patent specifications 28,061, this motor is of the four-cycle type with the two reciprocating cylindrical valve-sleeves arranged concentrically with the working cylinder. Power is transmitted to the operating mechanism from the main shaft through an enclosed skew and a vertical spindle to a lay or second shaft situated along the center of the cylinder head. The arrangement of the cranks, and valve-ports, upon the sleeves, and the movements of the sleeves, for the opening and closing of the valve-ports, is stated to be similar to present practice in the Knight type of motor. The shaft E1 carries upon it at a position at each end of each cylinder a pair of these cranks or eccentrics from which power is transmitted to the valve-sleeves.

**Riley Imparts Motion to the Sleeves in an Ingenious Way**

Referring to Fig. L, the section (A) through a cylinder of a motor shows the pair of sleeves S1 and S2 within the bore of the cylinder in the concentric relation with the piston with an inserted cylinder

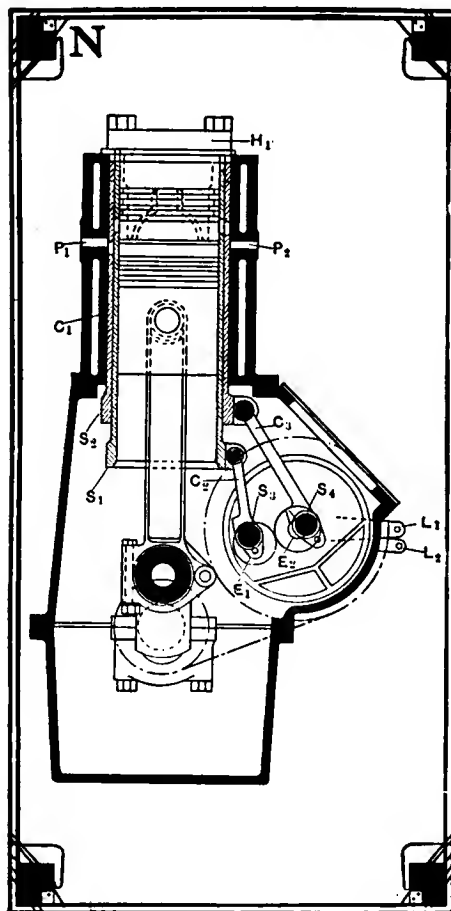

Fig. N—Sectional view of the Lanchester double sleeve valve motor, showing the method of operating the sleeves by epicyclic gearing

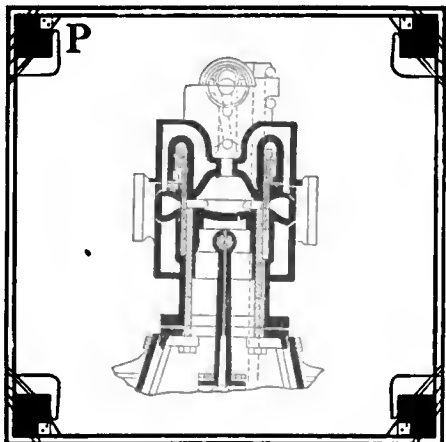
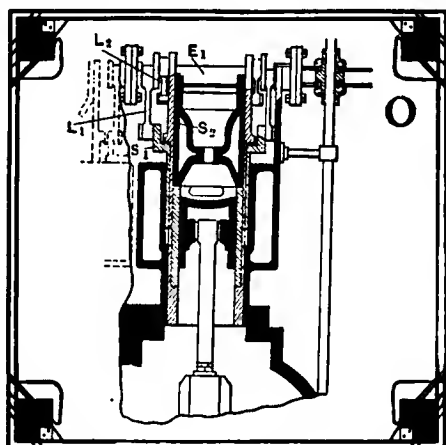

Fig. O—Longitudinal sectional view of the McIntosh motor in which the two sleeves are operated from an overhead eccentric shaft

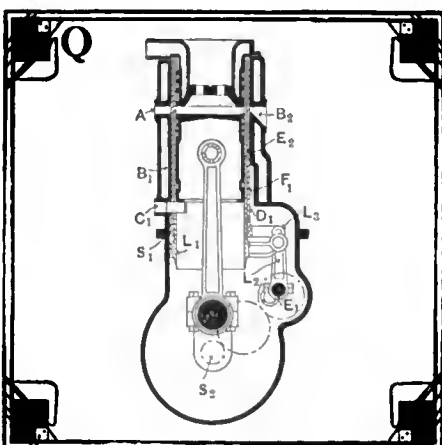

Fig. Q—Sectional view of the Chalmers motor, showing the two spherical sleeves interposed between the piston and cylinder walls and the intake and exhaust passageways

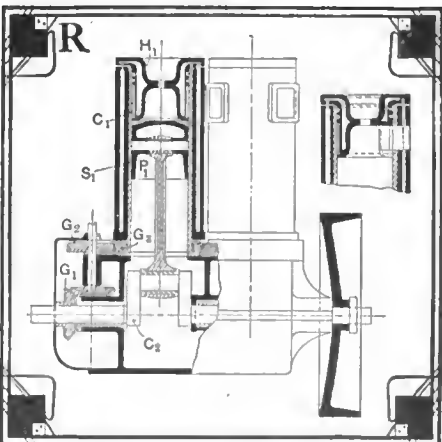

Fig. R—Longitudinal sectional view of the Carroll rotary sleeve valve motor and part section of a cylinder showing how the ports are uncovered

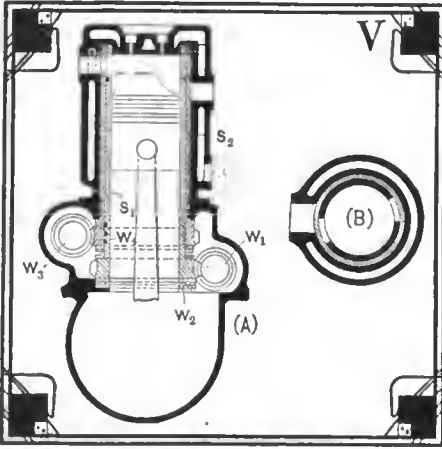
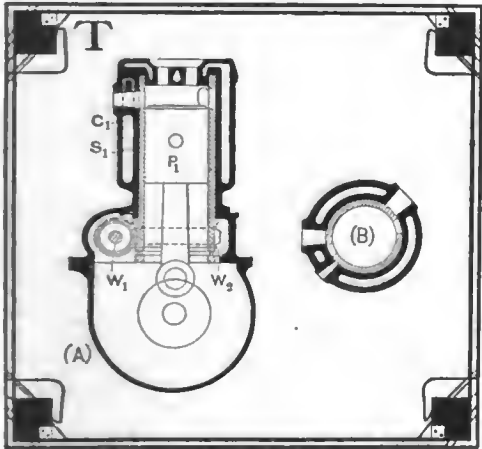
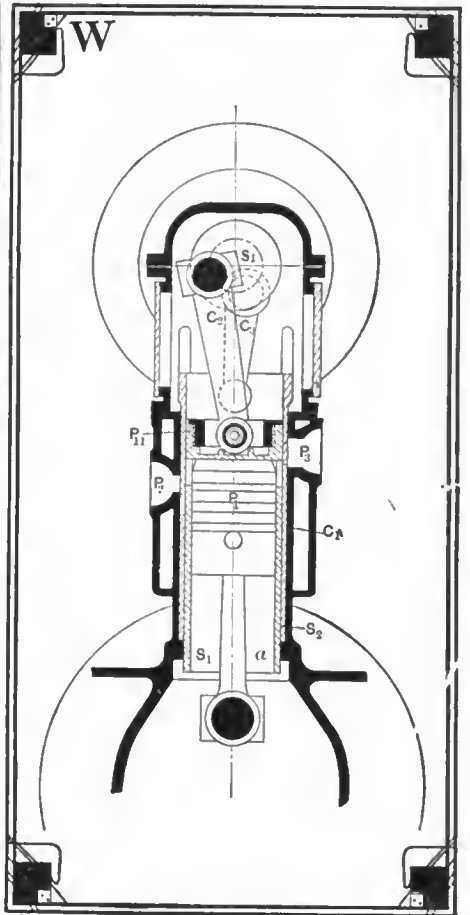
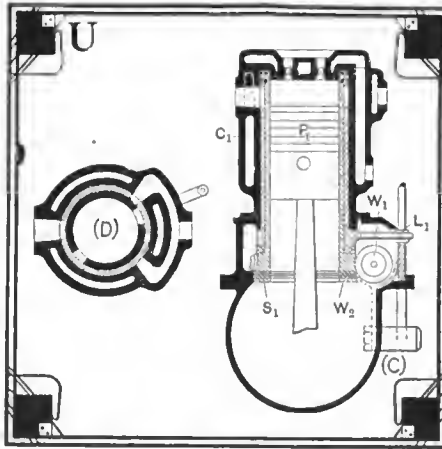
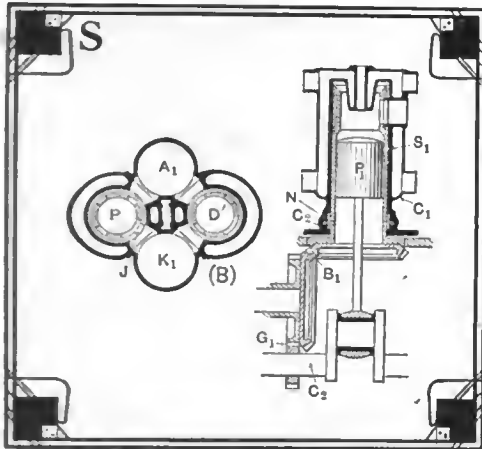

Fig. S—A shows operation of Callow & Humphrey rotary sleeve valve motor by means of bevel gearing. B, sectional view of cylinders, showing relation of packing ring to sleeve

Fig. T—Section of the Kitchen motor, showing how a single sleeve of the rotary type is operated by worm gearing

Fig. U—Another example of the Kitchen motor in which an outer sleeve is interposed between the rotary sleeve and the cylinder wall in order to regulate the admission and exhaust

Fig. V—A, sectional view of a further example of the Kitchen motor in which two sleeves of the rotary type are driven by worm gearing. B shows the relation of the water jacketed cylinder to the two sleeves

Fig. W—Sectional view of the Sears reciprocating sleeve valve motor, the sleeve being operated by an overhead eccentric shaft; in this type two pistons are used in each cylinder

head  $C_1$  and inlet and exhaust ports  $P_1$  and  $P_2$  as in the Knight motor, and the sketch (B) shows the four pairs of sleeves for an equal number of cylinders operated from an eccentric shaft  $E_1$  placed slightly in advance of the front cylinder of the motor, imparting motion to arms  $A_1$  and  $A_2$  lying parallel to each other in the plane of the crankshaft, the diameter of the cylinder apart and bell cranks, connecting these arms to the sleeves in the respective cylinders of the motor, imparting motion thereto.

**Carroll & Ripley Use a Single Rotating Sleeve**

In Fig. R showing the elevation of a motor in part section, and a single sleeve  $S_1$ , concentric with the piston  $P_1$  in the cylinder  $C_1$ , with an inserted head  $H_1$ , with means for water cooling, the sleeve  $S_1$  is rotated taking power from the crankshaft  $C_2$  through the bevel gear set  $G_1$  to the spur gear  $G_2$ , meshing with a gear  $G_3$  on the lower extremity of the rotating sleeve. As the sleeve rotates it covers and uncovers suitably contrived ports according to the four-cycle principle.

The sleeve of the adjacent cylinder is also fitted with a toothed ring which meshes with the tooth ring  $G_3$  and in this

manner takes motion therefrom. The small section of the cylinder head shows the sleeve as it is related to a post when either on the intake or exhaust stroke. The sleeve extends throughout the whole length of the cylinder, its port opening being sealed during compression and explosion by means of a semi-ring which is located in a corresponding recess, formed in the periphery of the head and a flat spring placed between the inner face of the semi-ring and the bottom of the recess. Packing rings are located in the head as a security against leakage.

**Callow & Humphrey Employ a Rotating Single Sleeve**

In Fig. S showing a cylinder of a motor in section, the sleeve  $S_1$ , in the cylinder  $C_1$  is concentric with the piston  $P_1$ , and the sleeve is rotated from the crankshaft  $C_2$  through a halftime gearset  $G_1$  and a bevel gearset  $B_1$  with one of the bevel gears flanged to the lower extremity of the sleeve  $S_1$ . The sleeve is provided with packing rings at the approach of both extremities protecting ports against leakage, controlling the inlet and exhaust flow to these ports in the cylinder walls. The section (B) through a pair of cylinders shows the horizontal section. The

port  $E$  in the sleeve is slightly larger than the port  $J$  in the packing ring, so that the pressure in the cylinder during compression and explosion stroke acts upon the exposed parts of the packing ring and secures good contact between it and the cylinder wall. At other points in the sleeve apertures  $D$  and  $D_1$  are provided for the purpose of increasing this effect. A gas admission chamber  $A_1$  and expansion chamber  $K_1$  are provided in communication with the inlet and exhaust ports of the cylinder respectively. Near the lower end of the sleeve  $S_1$  in Fig. S a collar  $C_2$  rests in a bearing  $N$  in the cylinder base plate.

**J. G. A. Kitchen Contributes a Quota of Sleeves**

Fig. T gives sections A and B of a rotating sleeve type of motor and referring to section A the sleeve  $S_1$  between the piston  $P_1$  and the cylinder  $C_1$  is given rotation by the worm  $W_1$  and the worm wheel  $W_2$ , the latter being on the bottom end of the sleeve within the cylinder and the rotation of the sleeve covers and uncovers the inlet exhaust port successively according to the four-cycle principle.

Kitchen also worked upon a design of a sleeve type of motor as shown in Fig.



U which is given in sections C and D. The inner sleeve S1 is operated by a worm W1 in mesh with a worm wheel W2 in the same manner as the rotation of the sleeve in the cylinder as shown in Fig. T. The two sleeves in Fig. U are concentric with the piston P1 of the cylinder C1. The outer sleeve in this motor is actuated by the lever L1 through a controlling mechanism, and the ports in the outer sleeve are so arranged as to control the incoming mixture.

Kitchen has also worked upon the double sleeve type of motor as shown in Fig. V showing a section through the cylinder at A and a section across the cylinder at B. In this motor the inner sleeve S1 is rotated by means of the worm W1 meshing with the wheel W2, and the outer sleeve S2 is given rotation by the worm W3 meshing with the wheel W4. The section B shows the relation of the ports in the sleeves, they being covered and uncovered, due to the rotation of the sleeves and the relation that exists between them.

### I. E. Sears Operates a Pair of Sleeves from the Top

Referring to Fig. W showing a section through the Sears motor, and the sleeve S1 concentric with the pistons P1 and P11 in the cylinder C1, covering and uncovering ports P2 and P3. Reciprocating motion is imparted to the sleeve through the eccentric shaft S1 by means of the connecting rod C2 for the auxiliary piston, and the connecting rod C3 for the sleeve. The sleeve is shown with the ports covered, and the operation of the motor conforms to the four-cycle principle. This motor differs from all of the other types illustrated to the extent that an auxiliary piston works in conjunction with the main piston in the cylinder.

**THE KAISER'S MOTOR CAR "FLEET."**—Emperor William of Germany has just purchased four more new types of automobiles, thus augmenting his motor car fleet to thirty and again emphasizing his stand as an enthusiastic motorist. The majority of his machines are of German and French make. Six of these cars are utilized as luggage vans. The Kaiser keeps five of his automobiles at Corfu. No other person is permitted to possess a horn like that used on His Majesty's motorcars, the type of horn being that of a peculiar fanfare. When in commission the car bears the Imperial Standard flag, which flies beside the chauffeur by day. This ensign is replaced at night by an illuminated glass shield, revealing the Standard in regulation colors.

**NEW FRENCH TRUCK BECOMING POPULAR.**—France has just introduced a new type of motor truck. It is equipped with a tilting platform, about thirteen feet in length, and a capstan. The truck has a capacity for carrying loads of great weight, which, by reason of platform and capstan, are handled both in the loading and unloading at a wonderful saving of hand labor. The platform is tilted over the rear axle, while the leading truck is run out upon the ground. After having loaded the goods upon the truck, the workmen draw the truck back upon the tilting frame by means of the capstan. The frame is then tilted back and locked in its place. Not only have manufacturing concerns and commercial houses adopted the truck, but the military authorities have put it into commission.

## Motoring in Touring in the

*Some information as to the best routes to follow in taking an fellow's masterpiece, with pertinent data, reinforced by a routes, by land and sea, by which the motorist may reach*



A—An upper reach of the St. John River, taken from the University at Fredericton  
B—Spillway at the outlet of Lily Lake, in Rockwood Park, St. John

C—Picturesque road leading up out of Grand Pré

D—Reversing falls at St. John, N. B., showing bridges, river and factories

ONE of the most needful adjurations to give the automobile tourist who would venture into the Maritime Provinces of Canada is "Keep to the left." Nor should the frisky driver forget that he must not trust the occasional level stretches of gravel road, which invariably terminate with an atrocious culvert, calculated to put the stoutest spring out of business. A car recently came from Fredericton with both front springs broken straight through the middle, as if cut with a knife. Then there are the hidden sharp turns at the bottom of steep pitches and on high, narrow embankments which one would do well to watch for. The most flagitious of these medieval road tortures are the stones which stick up in the road as if to test the toughness of the outer casing. At intervals in the early part of the season one encounters those patent road de-

# Modern Acadia

## Land of Evangeline

*automobile tour through the territory made famous in Longmap and excellent illustrations, showing the most comfortable Nova Scotia from New England. By Henry MacNair.*



E—Stretch of the lower St. John River, showing the character of the country  
 F—The tourist, on entering Digby, is impressed by its quaintness  
 G—Type of road to be found frequently; this one is at Gagetown, N. B.  
 H—Peniac Bridge across the Nashwaak River, near Marysville, N. B.

stroyers which scrape the mud, filth and vegetation out of the gutters into the middle of the road, rendering it all but impassable until the friendly showers wash it all back again. After plowing through some of the road which has been "fixed" one occasionally comes upon a modern road drag which is doing sane and satisfactory work at a minimum expense, and no other argument is necessary to convince one of the superiority of the road drag over the road scraper than to travel over two adjacent sections worked by these machines respectively.

Having decided to be content with an average of twelve miles per hour and to forget the bumps in the wonderful historic and scenic interest of this country, the tourist will find a trip to Acadia an experience which he will never forget. The accompanying map shows the principal touring routes in this section

with a connection from New York along the shore of New England, directions for which are shown in detail in Volume 2 of the Automobile Blue Book. Or one may ship his car to St. John or to Yarmouth, taking up the trip at either of these places. Perhaps the most satisfactory overland route to St. John is via Bangor, Bolton and Fredericton. From St. John two very interesting round trips offer themselves, the first being from St. John to Moncton, Truro, Halifax and Digby, returning to St. John by steamer or going on to Yarmouth and returning to Boston by steamer. The second, going from St. John to Fredericton, then across the heart of New Brunswick to Chatham, returning to St. John via Moncton. Another plan would be to drive from St. John to Edmundston, ship the car to Campbellton and then along the beautiful shore of Baie de Chaleurs and the Northumberland Strait to Moncton! then to Halifax and Yarmouth, returning to Boston by steamer. All of these roads are passable, and there are no unsurmountable difficulties, but the driving should be done with extreme caution and no great speed attempted. The tourist entering this part of Canada will find it necessary at the port of entry to arrange for a bond covering the amount of customs on the machine, which is 35 per cent. of the valuation. He must then secure a driver's license and register his car under the laws of Canada before proceeding.

The first impression of St. John is that of a very dull and dingy seaport, although it is picturesquely situated at the mouth of the St. John River and is historically interesting from the fact that Champlain and De Monts visited the harbor on the day of St. John the Baptist, June 24, 1604. The first European settlement, however, was made in 1631 by Charles de la Tour, who built a fort on St. John harbor. It would be interesting to follow the varying fortunes of La Tour and his successors as Acadia passed in turn from the British to the French and from the French back to the British. The real existence of St. John did not begin until after the landing of the United Empire Loyalists in 1783. These came from the neighboring United States, not desiring to unite their fortunes with the young American nation.

Among the various points of interest about St. John are Market Slip, the landing place of the Loyalists, where still stands a town bell used for calling workmen to labor and from labor to refreshment. Perhaps the best known natural feature is the reversing falls of the river St. John, where the river makes its way through a channel 450 ft. wide between tall cliffs of limestone. Here the tide rushing outward through the narrow channel gives one the impression of rapids or falls, whereas the incoming tide which here rises to about 25 ft. rushes in and reverses the condition. The favorite and most picturesque drive out of St. John is up the valley of the beautiful Kennebecasis, which extends for about 50 miles to the northeast. This road is the one to be taken to Moncton. Passing out of the Kennebecasis Valley, the tourist ascends a ridge from the top of which there is a fine view looking back. Then comes a descent into the valley of the Petitcodiac River, whose wet clay slopes at low tide give one the impression of a recent freshet. Moncton was named for an English general and is best known for the tidal bore which comes up the Petitcodiac River twice daily. This

wave comes in at the beginning of the inflowing tide and sometimes reaches a height of eight feet. The drive from Moncton to Truro down the isthmus is picturesque in spots, but unless the coast road is taken through Parrsboro one is very likely to find rough going.

One of the most interesting parts of the trip to Halifax is along the chain of lakes which begin south of Shubenacadie. Halifax might be called the Ultima Thule for American automobile travel, for beyond it one cannot go. The city itself boasts of several good hotels and is by far the most interesting and picturesque city of the two Provinces. Its most conspicuous feature is the Citadel, which occupies a commanding position at the topmost elevation of the small peninsula upon which Halifax is located. This hill was fortified in 1778, but the present fortress was begun in 1794. From the Citadel an unexcelled view of the city harbor may be had.

The drive from Halifax to Windsor, a most interesting one, follows the shore of the harbor to Bedford, when it ascends Mt. Uniacke on a very rough and stony stretch. At Windsor is the head of the Basin of Minas, made immortal by Longfellow in his "Evangeline." Shortly beyond the road leads through Grand Pré, the scene of the principal happenings so vividly outlined in that wonderful drama-poem. Leaving the Basin of Minas, the road leads over a low bridge and descends into the Annapolis Valley, whose beauty and charm have often been sung.

At Annapolis Royal is an old fort dating from 1660 and a monument to Sieur de Monts. Digby is a picturesque little village at the mouth of the Annapolis River, which passes into the Bay of Fundy through Digby Gut. Steamers ply between this point and St. John, and if one is tired of the trip the boat may be taken across the bay, or the trip may be continued to Yarmouth, where there are excellent hotel accommodations and steamer connections to Boston.

Of the other interesting automobile trips to the Provinces the most popular is from St. John to Fredericton, either by the river road or the back road, the river road being the most in favor on account of the beautiful views of the St. John. From Fredericton the tourist should follow the valley of the Nashwaak River and descend into the valley of the Miramichi, known as the fishing grounds of Canada. From Chatham an indifferent road runs across the marshes through several small villages into Moncton, and the return trip is made to St. John through the Valleys of the Pettitcodiac and Kennebecassis Rivers.

## In Further Relation to Lubricating Problems

*Charles E. Duryea presents additional argument in support of putting the lubricating oil into the gasoline and supplying these products to the motor in mixed form on the ground of simplicity.*

I AM unable to get away from the feeling that you, for some reason, are opposed to accepting a good method of oiling. I am unable to find anything in your argument that is really against the mixture method as proposed by me. That there is, as an inadvertence, some mixing of the oil with the new charge in the crankcases of every two-cycle engine goes without saying. But what of it? The mixture method of feeding oil into a two-cycle crankcase, according to my view, is not an inadvertence. I look upon it as a well-planned and accurately operating method, which is superior to other methods. You might say that it was an inadvertence when Columbus discovered America, but he worked under an up-to-date plan and deserves credit accordingly.

Your play on words in your endeavor to show that the mixture method of feeding oil is a complex method, in my judgment, is unworthy of you. I venture to assert that none of your readers have been confused by the terms employed. They know that when we speak of the virtues of simplicity

we do not refer to a type of machine which is lacking in some vital part, whereas we do have in mind the type of machine that has the minimum number of parts and is capable of performing a given service. The mixture method of lubrication dispenses with the oiling machinery as far as the engine lubrication is concerned, substituting a method which I consider more nearly correct in action and more certain to deliver the desired results. This, I take it, is the kind of simplicity that the user wants.

That the mixture method of oiling is mostly applied to two-cycle engines is no argument against it. One four-cycle engine that I know of is built that way, and I have no doubt that others will be so made. Practically every engine nowadays is built with a tight crankcase to keep out the dirt. Just why a mixture may not be carried into the tight case and

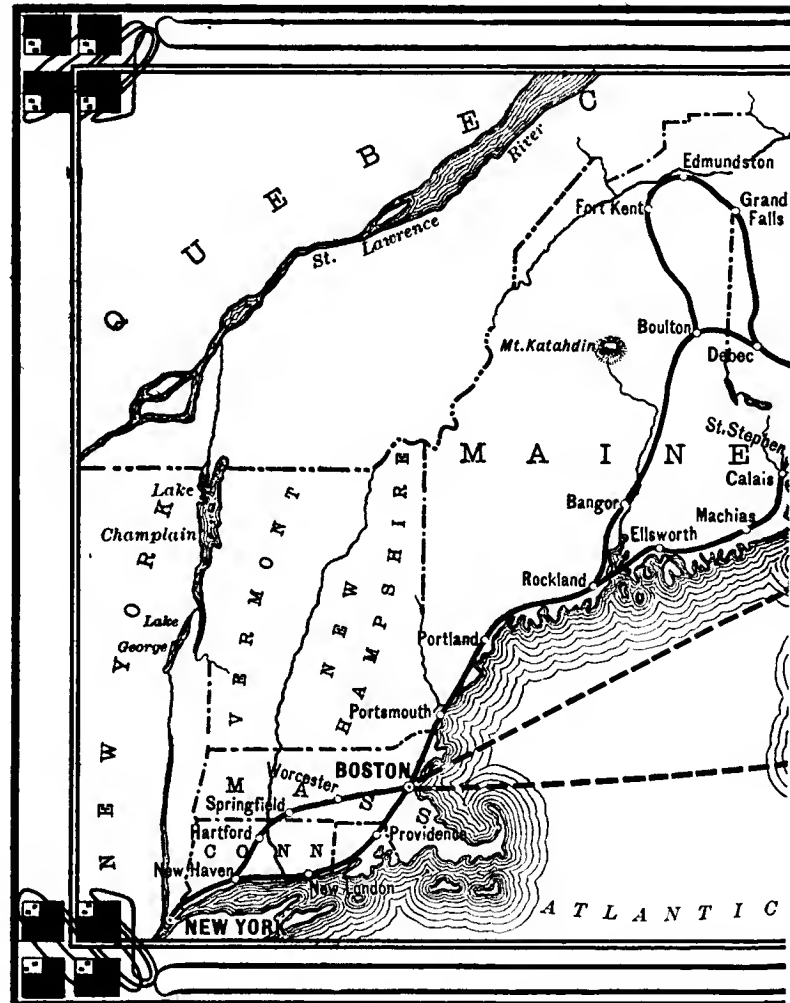

Map showing the geographical relations of the New England States to Nova Scotia, (Courtesy of the Official

out again, as is done by Holsman, I do not see. It is very possible that engine makers have something to learn yet. It is certain that such a method would render needless some of the parts now considered necessary, and this is the thought that every up-to-date engineer keeps in mind and works for. The engineer knows that needless parts add needless cost in the first place, may offer trouble in the second place, must be kept in repair in the third place, and eventually replaced in the fourth place, not to mention the weight that the presence of these devices would necessarily add, nor forgetting the power that they absorb. I trust that these discussions will at least make designers think.

In the absence of a means for regulating discussion, the germ of irrelevancy creeps in with great persistence, and argument is prone to browse around over a 40-acre lot, making it substantially impossible to adhere to the original subject and to arrive at some conclusions.

The first principle of efficient lubrication is founded on the idea of an

unbroken film. The only way that an unbroken film can be assured, referring to the film of lubricant between the journal and the bearing, is to employ a suitable grade of lubricating oil and to be sure that it is not adulterated. As to the question of adulteration, it is not difficult to reach the conclusion that lubricating oil with gasoline in it is adulterated, nor does it matter whether the gasoline is put in it on purpose or otherwise.

Granting that Columbus discovered America, it is not without contending that the good Queen Isabella furnished the lubricant up to an unadulterated standard, and she must have appreciated how necessary it was to avoid adulteration, since there are those who suspect that she put her jewels in pawn to get the gold (lubricant) that Columbus used as the price of his outfit. In the Holsman motor, which is used as an example for designers to go by, it still remains to say that the plan was in the nature of an inadvertence, in view of the fact that Holsman would have had great difficulty in doing the work in any other way but the one as chosen by him. It is no argument to state that a thing is better if it is done in a certain way, if it is a fact that the doer of the job has none but a Hobson's choice.

We are struck by the funny way that users have of showing their high appreciation of simplicity, for, as Mr. Duryea states, "this is the kind of simplicity that the user wants." Statistics would seem to indicate that the users of automobiles are so taken with the mixture idea that 99.9 per cent. of them invest their money in something else.

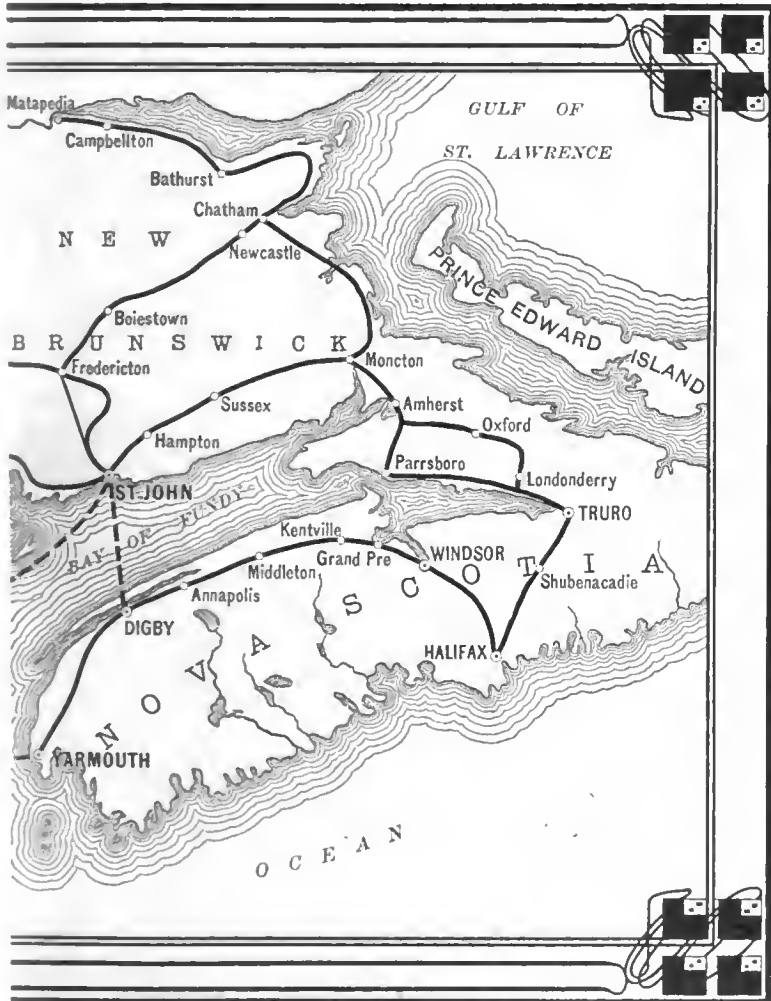

with the best routes to and from the Land of Evangeline, both by land and water (Automobile Blue Book)

### Hot Weather Tip

Those who use the ordinary type of bulb operated horn may find that during the hot weather the bulb, which is usually made of rubber, becomes very sticky. This can be overcome if a small bag is made out of a piece of linen and sewn over the bulb. A more permanent fitting can be made of leather and attached by a lacing.

**GOVERNMENT MOTOR CAR SERVICE IN EAST AFRICA**—From the East African Protectorate word comes that a plan is being worked out whereby motor car service is to be established by the Government for the accommodation of the postoffice, and likewise for landowners who raise perishable produce. The highways have been improved and the outlook for automobiles in this section is bright.

## It Stands to Reason—

- THAT you cannot discriminate against the motor in your automobile without being paid in coin of the same realm.
- THAT discontent is catching; if you invest in a discontented automobile you will experience discontent within a week.
- THAT a good automobile should not be disassociated from a kindly disposed owner.
- THAT a dramatic critic of some power might have a lot to say about an intoxicated driver.
- THAT the owner of an automobile should deprive the dramatic critic of his opportunity.
- THAT subjects for discussion should not include deflated tires in service.
- THAT a straightforward type of motor in a car is entitled to frank and fair treatment.
- THAT a drone in the chauffeur's seat makes an active repairman in the shop.
- THAT drudgery is a condition that rests under the shadow of previous neglect.
- THAT a chauffeur arrayed in an alcoholic mind is an economic blunder.
- THAT chauffeurs are too often the victims of a bad example.
- THAT a long stop at a road house is the first indication of a wrecked automobile.
- THAT "sand" is more appropriate in the gizzard of the driver than it is in the gearbox.
- THAT the glamor that is hinged to a coat of red paint on the body is not necessarily the sign of a good automobile.
- THAT the designer who will make a little room for wearing apparel will be on the highway to fame.
- THAT the rattle of tools in a poorly contrived box makes faces at a silent motor.
- THAT a self-binding reaper from the land of trouble has a monkey-wrench in the hands of a "bonehead" as its partner.
- THAT fixing an automobile piecemeal is like handing money to a burglar for safe keeping.
- THAT the path of glory may lead to a grave, but it is a short one for the fellow who drives fast without looking ahead.
- THAT it is better to "get a horse" to rescue an automobile than it is to get an ambulance to succor a reckless driver.
- THAT the shortest distance between two points is not necessarily through a fence into a corn-field.
- THAT it is useless to waste sentiment upon a motor—what it needs is lubricating oil.
- THAT motors must have an enjoyable time telling each other funny stories when they get back to the garage.

## Standardizing Signals

*The feasibility of securing the adoption of a law which shall render it obligatory for motorists in the United Kingdom to equip their cars with uniform warning signals has been discussed, it being asserted that the present multiplicity of such devices has a tendency to "rattle" pedestrians.*

ENGLISH law makes it compulsory upon automobilists to "carry a bell or other instrument" on motor cars. To this end the Local Government Board says that the signal "shall be used whenever necessary." This rather indefinite phrase is sometimes hard to interpret, for example, in a case of alleged neglect, when the matter is referred to a Magistrate. But the problem of the motor car horn, "hooter," siren or "road clearer" has become so great and the kinds of "instruments" in use so numerous that both motorists and pedestrians are in a muddle. To get out of it they are considering the feasibility of calling upon the respective Local Government Boards to agree upon some one definite type of horn to be used. Throughout the country English motorists seem to show a liking for a certain type of bugle, which contains ten notes, comprising the diatonic scale of the key of G with F sharp and an extra A added.



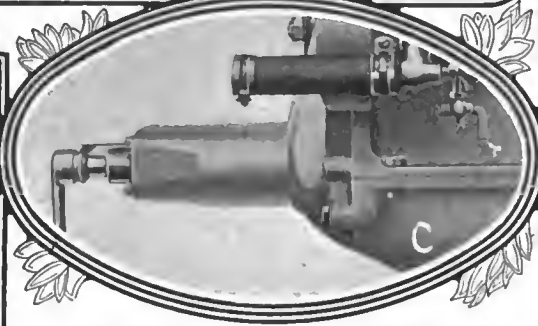
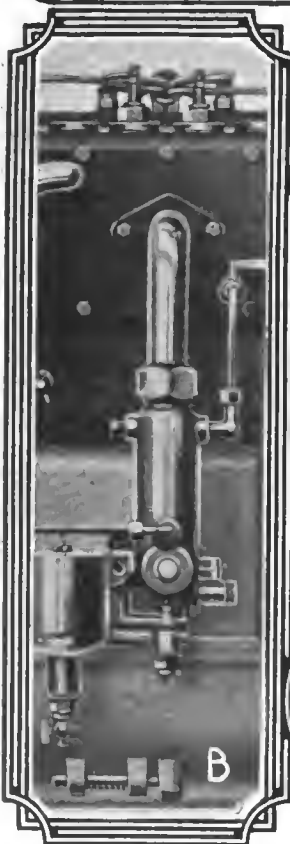
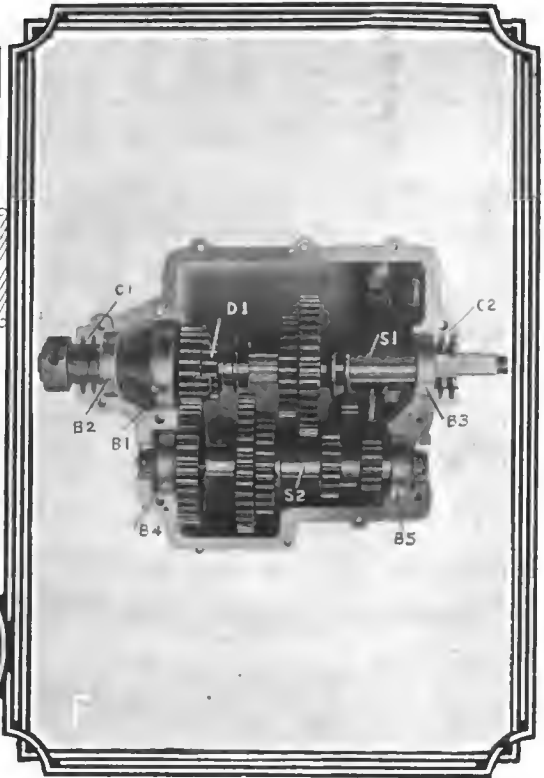
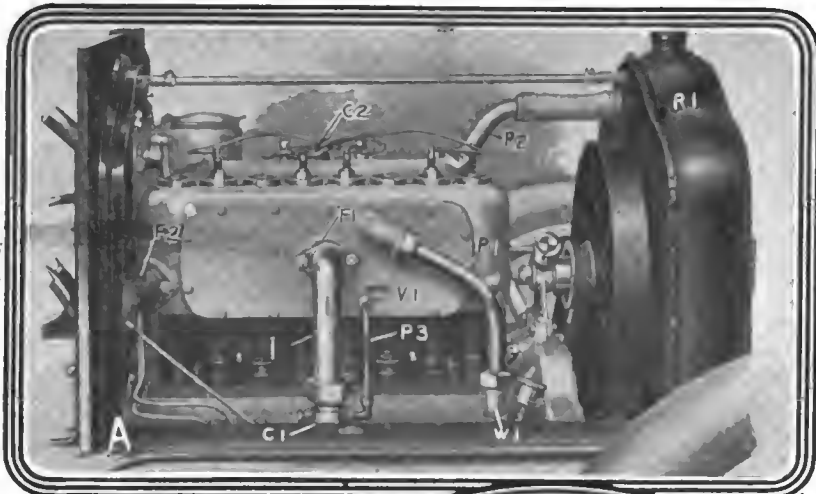

## White Company Adds "Six"

Continues to Make Steamers

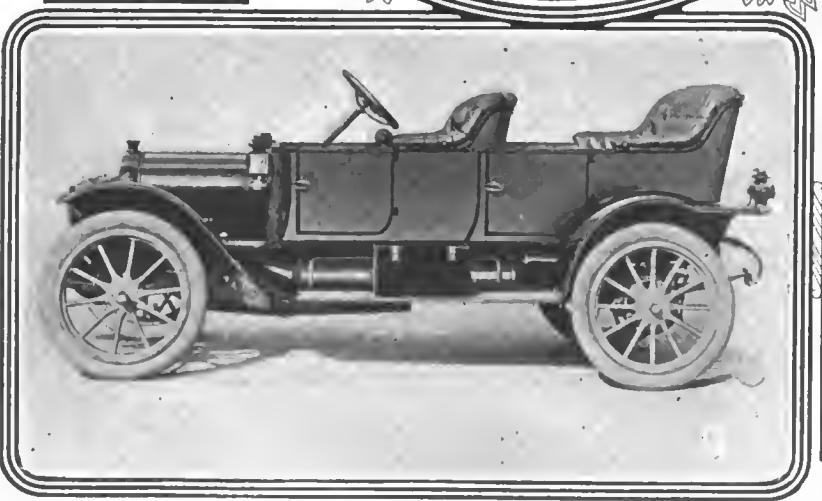
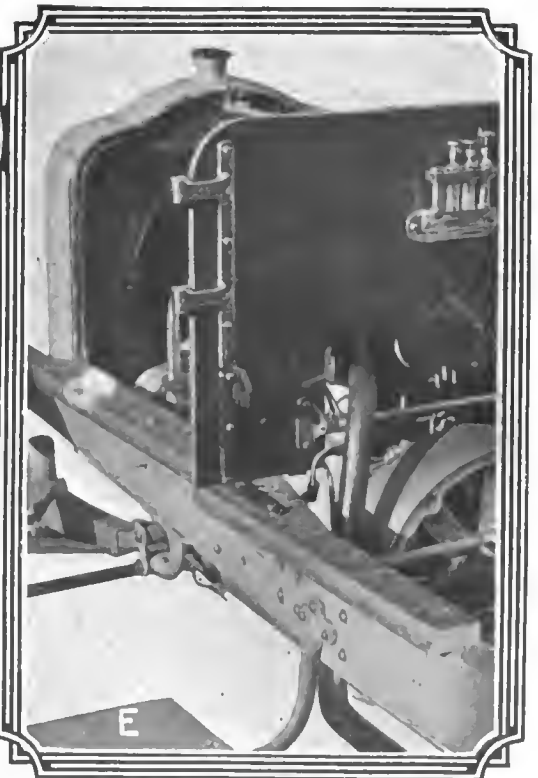
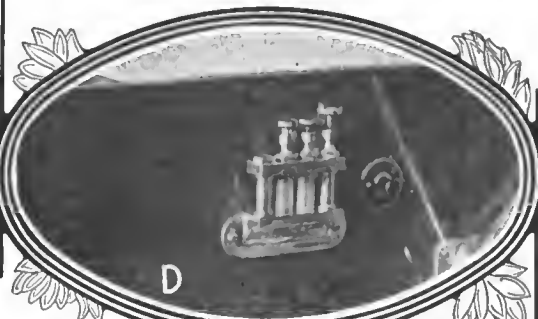

A—Left-hand side of the "GE" White motor with valve cover removed. B—Showing the carburetor of the 30-horsepower White gasoline engine together with hot-water jacketing and valve covers. C—Front end of the motor, showing the extension of the crankcase and starting crank. D—View of the dash of the White "30," showing the switch and sight-feed lubricator. E—Side view of the 1912 fore-door White touring car. F—Gearset of the White 1912 gasoline car, showing the high-speed pinion in mesh. G—Part view of the 1912 White "30" chassis, showing the method of suspending the transmission and the operation of the gear-shift.



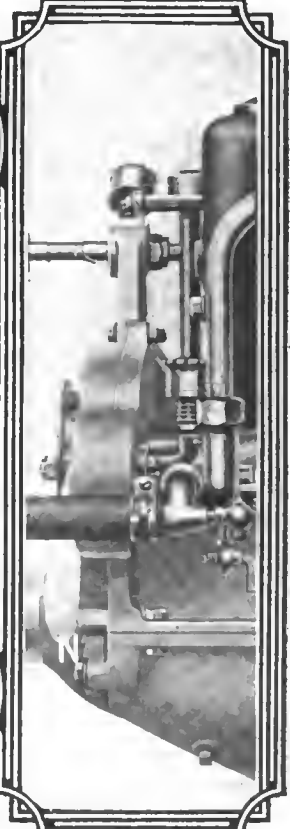
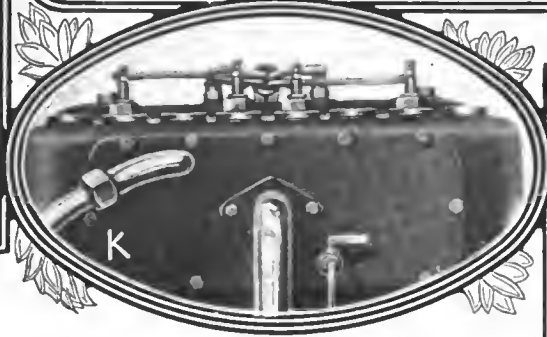
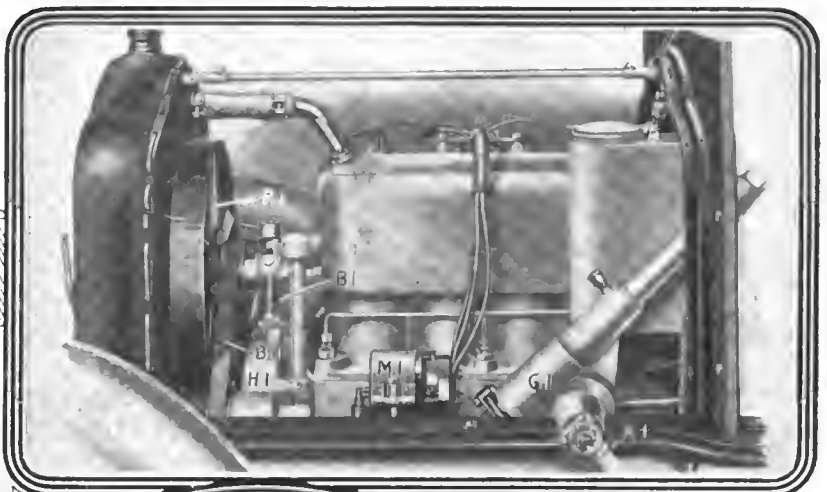
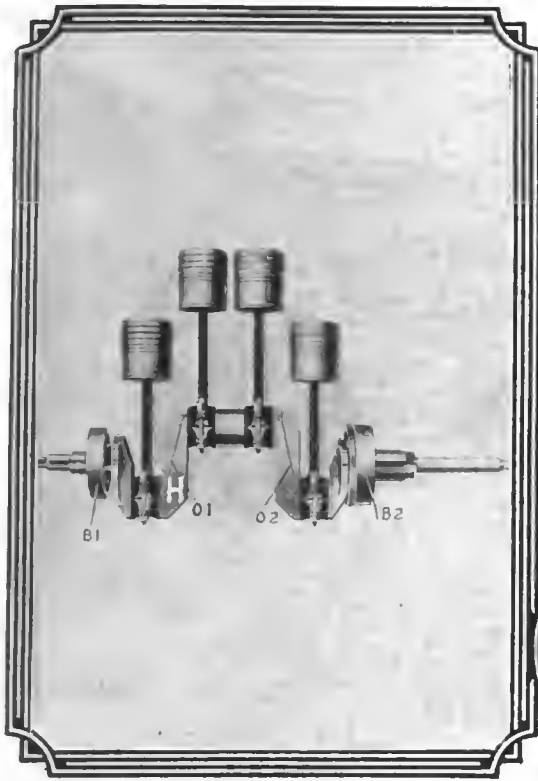

**to Gasoline Automobile Line**  
**in Response to the Demand**

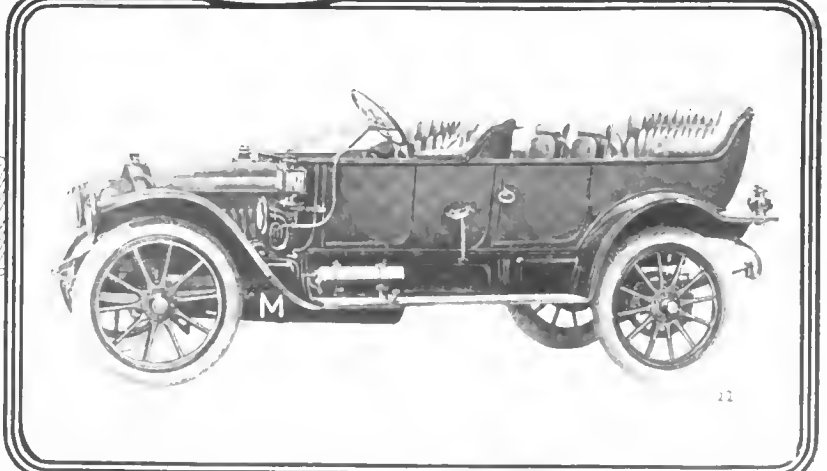
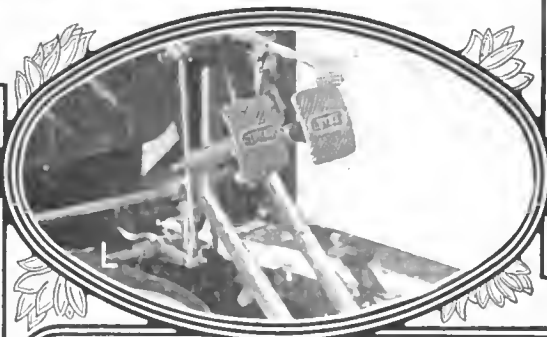
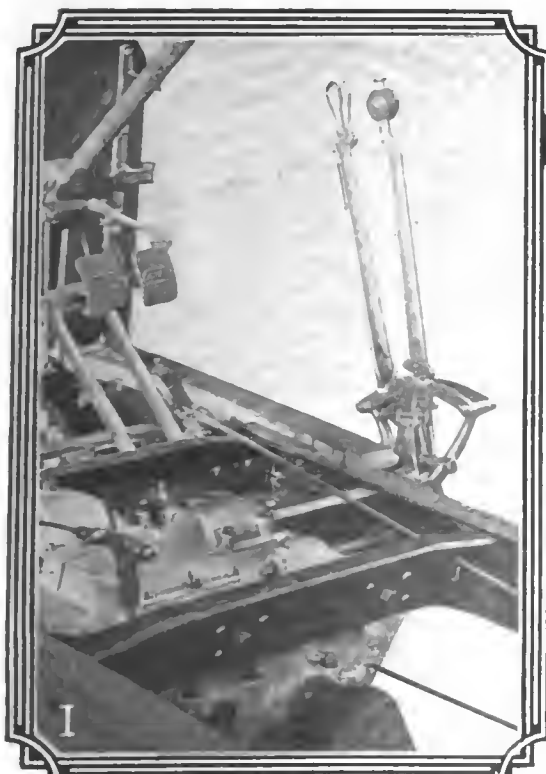

H—Crankshaft of the White 1912, showing the ball bearing supports and the oil leads. I—Front end view of the White "30" chassis, showing the leather-faced clutch, the broad section of the chassis frame, and the shacking of the front springs. J—Right-hand side of the gasoline "GE" engine, showing the position of the magneto, fan, steering gear and lubricating oil tank. K—Side view of the White gasoline 30-horsepower motor, showing the intake manifold, water connection and spark plug. L—View of the foot control, showing the clutch, brake and accelerator. M—Side view of the seven-passenger White gasoline touring car with left-hand control. N—Side view of the front of the 30-horsepower White motor.

*In view of the demand as it is felt by the company for steam as well as gas automobiles, the steam models are continued substantially as heretofore, and the gas models have been revised and brought up to date, adding a "six," according to the illustrations given with this article, and in line with the following discussion.*

WITH a six-cylinder to be known as a "60," including suitable revisions of the "30" and "40" models, the White Company, of Cleveland, Ohio, is prepared to meet its clientèle with a view to filling its devious wants, with the same degree of care and precision that has been the underlying principle of the company's activities heretofore. A striking feature of the new six-cylinder model lies in the fact that the six cylinders are cast *en bloc*, thus bringing this new car into the same school of design as that which characterizes the four cylinder models of the same make.

The 1912 line comprises four different chassis under catalogue designations "GB," "GE," "GAD," and "GF." The "GB" model is the 30-horsepower chassis mounting a limousine or a landaulet body. The "GE" is the 40-horsepower chassis mounting five or seven-passenger touring bodies, also limousine, Berline limousine or landaulet bodies. The "GAD" is the 30-horsepower chassis mounting a new touring body, and the "GF" chassis represents the new six-cylinder model. This model is made up with a seven-passenger touring body, or the purchaser may have the option of a landaulet, limousine or a Berline limousine.

All bodies, whether for open or closed cars, are built with foredoors. The body list also includes a toy tonneau on the "30" chassis, and a roadster body on the "30" and "40" chassis.

#### Discussing the Mechanical Features of White Gas Cars

Referring to Fig A, showing the left-hand side of the Model "GE" engine, the carbureter C1 is attached to the upward sweeping intake I1, leading to a flange F1 about midway on the block casting of the cylinders. The water pump W1 delivers water to the cylinders through the pipe P1 circulating the cold water around the inlet and exhaust valves which are on the same side of the motor, and the water passes out at the top through the pipe P2 to the radiator R1 in front, the latter being of the well-known White design, and similar in appearance on gas and steam models of this make of car. The exhaust passes out through the fitting F2 to the exhaust pipe which sweeps down, clearing the flywheel, to a position clear of the chassis frame, back to the muffler, and away to the atmosphere. The high-tension leads come through the conduit C2 to the top of the cylinder casting and are connected to the four spark plugs placed in the covers over the respective inlet valves. The carbureter is provided with a water jacket, and the hot water required for heating the auxiliary air passes down through the pipe P3, a valve V1 being placed in the length of the same, so that the water can be shut off if the occasion requires.

The opposite side of the "GE" motor is presented in Fig J, showing the magneto M1 near the front end of the motor, taking its drive by a shaft terminating in a gear, the latter being in the halftime train and enclosed by a housing H1. On this side of the motor, the steering gear G1 comes into view with the steering arm A1 on the end of a shaft extending out of the steering gear housing above the top of the chassis frame. The air propeller P1 is substantially mounted on a bracket B1, and power is delivered from a shrouded pulley on a shaft extending out through the front end of the halftime box, transmitting the power by means of a belt B11 to the fan pulley. The motor is suspended on the frame at three points, and this method of suspension is also applied to the gearbox. Referring to the details of the cylinder castings, the intake and exhaust passages are integral parts of the castings. It is claimed for this method of casting the cylinders that alignment is assured; moreover, the gases are delivered to the cylinders at a temperature favor-

able to ready combustion, and the disposal of the burnt gases is facilitated. The length of the crankshaft is minimized under this plan, and the resulting compactness of construction also reacts favorably upon the total weight of the motor.

The White type of transmission gear is shown in Fig. F with a direct drive at D1 and a large annular ball bearing E1 supporting the load at this point, and a second annular ball bearing B2 aiding in the support of this shaft. A double-grooved closure C1 excludes foreign matter from these bearings, and a similar closure C2 excludes foreign matter from the annular type ball bearing B3 which is placed to support the other end of the prime shaft S1 which is splined. The layshaft S2 is supported by annular type ball bearing B4 and B5 and foreign matter is excluded from them by means of covers placed over the ends of the housings. The transmission gear is conspicuous for its clean designing, good relations from the clearance point of view of the torque, and the excellence of the material employed.

The crankshaft as shown in Fig. H is of the two-ball bearing type with annular type ball bearings B1 and B2 near the extremities. Oil tubes C1 and C2 are shown in the lubricating system, and in order to defeat flexure the crankshaft is made with large-section throws and pins of the most approved form of material that is available for this purpose. The connecting rods are of neat design, and the well-fashioned pistons are provided with oil grooves in addition to three piston rings, and a condition of exact balance is established as a part of this undertaking.

The remaining illustrations will suffice to indicate consistency in methods of design and construction of the cars, and indicate how the various problems have been disposed of. Referring to the transmission gear it provides four forward speeds and reverse with direct drive on the third, making the gear changes selectively. The gears are of heat-treated steel. The clutch in the flywheel is of the cone-type and the leather facing is held in place by T-bolts with means for their ready removal if the occasion requires. The driving shaft is fitted with two universal joints, and no telescopic joint is employed. Leather boots are put over all joints to exclude foreign matter. Grease cups are provided at points of vantage. The coupling between the clutch and the gearcase is flexibly arranged, allowing for slight variations in alignment. The machinery equipment is protected from dust by a well-designed sheet-metal pan.

The rear axle is of semi-floating type. In the construction of this axle there are three principal divisions; the gearcase and the right and left axle sleeves. A heavy truss extends from the ends of the axle sleeves engaging a saddle on the under side of the gearcase, helping to support the load. The gears in the axle case are accessible through a large cover on the top of the axle housing. The jackshafts in the axle are of heat-treated steel. The gears are removable without splitting the gearcase.

The front axle is a one-piece drop-forging of the I-section made of .40 carbon steel. A ball thrust is interposed between the steering arm and the axle.

The crankcase is of specification aluminum in two sections. The upper section carries all of the working parts. The lower section is limited in its duty to the exclusion of foreign matter, and the holding of oil. It may be well to say here that the motors are of the long-stroke type. The 30-horsepower motor has a bore of 3 3-4 inches and a stroke of 5 1-8 inches. The 40 horsepower motor has a bore of 4 1-4 inches and a stroke of 5 3-4 inches. The six cylinder 60-horsepower motor has a bore of 4 1-4 inches and a stroke of 5 3-4 inches. Ignition is by high-tension magneto. The mixture is made by a White carbureter of the aspirating type with air valves graduated to supply a correct mixture under varying conditions of speed, the air being heated by means of a water-jacket.

The system of lubrication is a combination of "splash" with a positive feed. There is a direct feed to each of the two main crankshaft bearings. Each connecting rod bearing is also posi-

tively lubricated by means of all oilways that are cut through and carried on the crankshaft. These oilways are supplied centrifugally through oiling grooves on the crankshaft. Provision is made to insure an abundant supply of oil to the camshaft bearings.

The halftime gears are properly lubricated and a means for lubricating the water pump and magneto drive are also at hand.

The engine being water-cooled is supplied with the cooling fluid by means of a gear-driven centrifugal pump. A genuine honeycomb radiator is used, in the design of which an effort has been made to take advantage of all four sides of each air cell by providing water upon the adjacent surfaces. The water piping, like the rest of the piping throughout the automobile, is a well-executed piece of work. The side bars of the chassis are of heat-treated steel. Front springs on all models are of the half-elliptic type, and the rear springs on all models are of the three-quarter elliptic type. The steering mechanism is of the worm and sector type with ball-thrust bearings. All parts are of heat-treated steel. The gas and spark may be regulated from the steering wheel or by means of foot levers. The gear-changing and emergency brake levers are arranged at the side of the driver. The clutch and service brakes are operated by pedals. There are two brakes on each rear wheel acting on wide drums of wide diameter. The brakes operated by the pedals are fiber-lined, external constricting type. The emergency brakes, operated by the hand-lever, are internal expanding, metal-to-metal type.

Annular type ball bearings of liberal proportions are universally applied in all models. A compression release is used and operated through a small lever on the frame near the radiator which relieves the compression in the cylinders while the engine is being cranked. The mechanically operated valves are interchangeable. The inlet and exhaust valves are situated on the same side of the cylinders. The valves are made with integral stems, and the type of metal employed has been selected for its ability to resist distortion due to heat. The valve springs and stems, together with the relating mechanism, are set in a valve chamber within the cylinder castings protected thereby but accessible through openings that are covered by means of detachable plates. The camshaft of special heat-treated steel is entirely enclosed within the crankcase.

In the operation of these cars various innovations that count for comfort of the driver have been given a fitting measure of care, as, for illustration, the pedals are adjustable as to length and position, and thought has been given to the location of the steering wheel with respect to the seat and accessibility of the levers for purposes of control. The peace-of-mind of the driver is assured through the good office of a well-contrived lubricating system, the ease with which lubricating oil may be

added at will, and the facilities for telling the driver how much of the lubricating oil remains, and the distribution of grease cups at points of vantage adds materially to the insurance feature, so that the probability of trouble due to lubrication, or noise due to undue wear of the parts, is avoided. The weight of the automobiles in proportion to the available power in each case has been fixed with a view to good road performance, and the harmonizing of the relations of the functioning units has been brought about by a careful study of the needs in the light of experience.

## Charging for Repairs Not Ordered

*Some garage owners have contracted the habit of overhauling their patrons' cars without authority, rendering a stiff bill, and holding the cars in the event of a refusal on the part of the owner to pay.*

REFORMS come under the press of necessities, and the men who keep their automobiles in public garages are being impressed with the fact that the rental charge is but a small percentage of the total of the bill in some cases, due to the success with which garage repairmen find troubles in the cars of their patrons and to the further fact that work is done in the correcting of these troubles perhaps too soon. In the long run the owner of an automobile is bound to count the total cost, and it should not take him more than a year or two to arrive at the conclusion that a \$300 garage in his own back yard, under the charge of a machinist-chauffeur, is a better investment than paying \$30 per month to keep his car in a garage and an extra \$100 per month to cover the cost of mysterious repairs that he never orders. Every owner of every automobile that is kept in a public garage should serve notice upon the proprietor of the garage that he will pay no bill whatever for any work done unless he delivers a written order for that work to the owner of the garage. In the meantime, there is a law upon the statute books of the State of New York which protects the owner of the garage from "bad pay," it being within the law for the owner of a garage to seize a car and hold it in his possession until the owner thereof pays for any repairs that may be made upon it. This law was intended for the worthy purpose of protecting repairmen from "dead beats," but here and there information comes to hand which goes to show that some garage repairmen undertake to overhaul automobiles that are stored in their establishments without getting permission from the owners of the cars, and they force the owners to pay for what they do not order by holding such automobiles ostensibly under this law until the repair bills are paid.

## Blue Book Cars Under Way

### Opening Up New Fields and Improving Past Endeavors

*In order to cover as much ground as possible three Blue Book cars are now under way. This is one month earlier than in preceding years. Many new roads have been built during the last season and it is proposed to include these in next year's volumes. Another volume will be added to the 1912 list, making five in all.*

IT is not so many years ago that the routes of America were comprised in one volume, but since 1907, with the aid of a fleet of cars, the territory has been enlarged annually, and

last year's four volumes were a great improvement on the preceding years' production.

This year the fleet of three cars is starting one month ahead of previous years' schedules and will remain in the field of useful endeavor until the snow flies. The object of the three cars is to cover as comprehensively as possible previous routes, and besides planning new routes they will plot the new State highways that have been made during the last twelve months. These are becoming an important factor, as the good roads germ has taken hold of most rural districts, whose inhabitants grasp what the automobile has done for the sections where automobile traf-

fic has been opened through the roads being put in proper repair.

The Blue Book was started in 1901, and with yearly additions was, as before stated, comprised in one volume till 1907, when two volumes were found necessary. In 1908 it was enlarged and the three volumes which were published were highly appreciated by tourists. In 1910 four volumes were required to give the information on the territory that had been covered and many useful maps were added. The 1911 season saw the same number of volumes as the preceding year, but the information was largely added to and the usefulness to the tourist greatly enhanced. This year will see another addition in a volume which will comprise routes from the Mississippi to the Rockies, with extensions to the coast of the Pacific.

The car shown in the accompanying illustration will cover the ground included in Volume II of the Blue Book which comprises New England and Canada. This has been the favorite ground of many Eastern tourists, and it is expected that the car will cover 20,000 miles before taking to winter quarters. Much new ground will have to be gone over and it is the endeavor of the pilots to increase the fund of information as much as possible.

Car No. 2 will cover the territory included in Volumes I and III, which comprises the Province of Ontario and the State of New York. The volume covering Pennsylvania, New Jersey and the South is expected to be greatly improved, as the car will take advantage of the southern winter to extend its field when the other cars will be compelled to stop. This car is expected to cover somewhat over 25,000 miles.

Car No. 3 will take Volumes IV and V in hand, which includes

from the Ohio to the Mississippi and from the Mississippi to the Rockies respectively. The schedule for this car is 30,000 miles, the additional mileage being due to the distance between the various towns. Extensions to the Pacific Coast will be included in Volume V, which will lead to a further extension in the future to the additional Volume VI, which will cover the Pacific Coast. The three cars will be distinguished by the signs placed on the radiator and sides of the cars.

**SYNTHETIC RUBBER**—It must be a long time before synthetic rubber seriously affects the price of rubber, but it has to be reckoned with. Dr. Gerlach has been giving his views on it before the Rubber Commission recently appointed by the German Colonial Agricultural Committee, and they are worth noting. In the beginning Dr. Gerlach was skeptical as to its value, and was very much surprised when bulk samples satisfied him that synthetic rubber possesses the essential properties of high-grade material. To what extent the new product will compete with natural rubber remains to be seen. The raw material of synthetic rubber is itself a manufactured article, the production of which, on a large scale, can only be undertaken by a few chemical firms, but there can be little doubt that artificial rubber will eventually appear on the market as a commercial product. Dr. Gerlach thinks that makers will take care that the output is not on a scale sufficient to depress the price of rubber. However that may be, producing costs will have to be largely reduced before serious competition with natural rubber is possible.—*Royal Society of Arts Journal*.

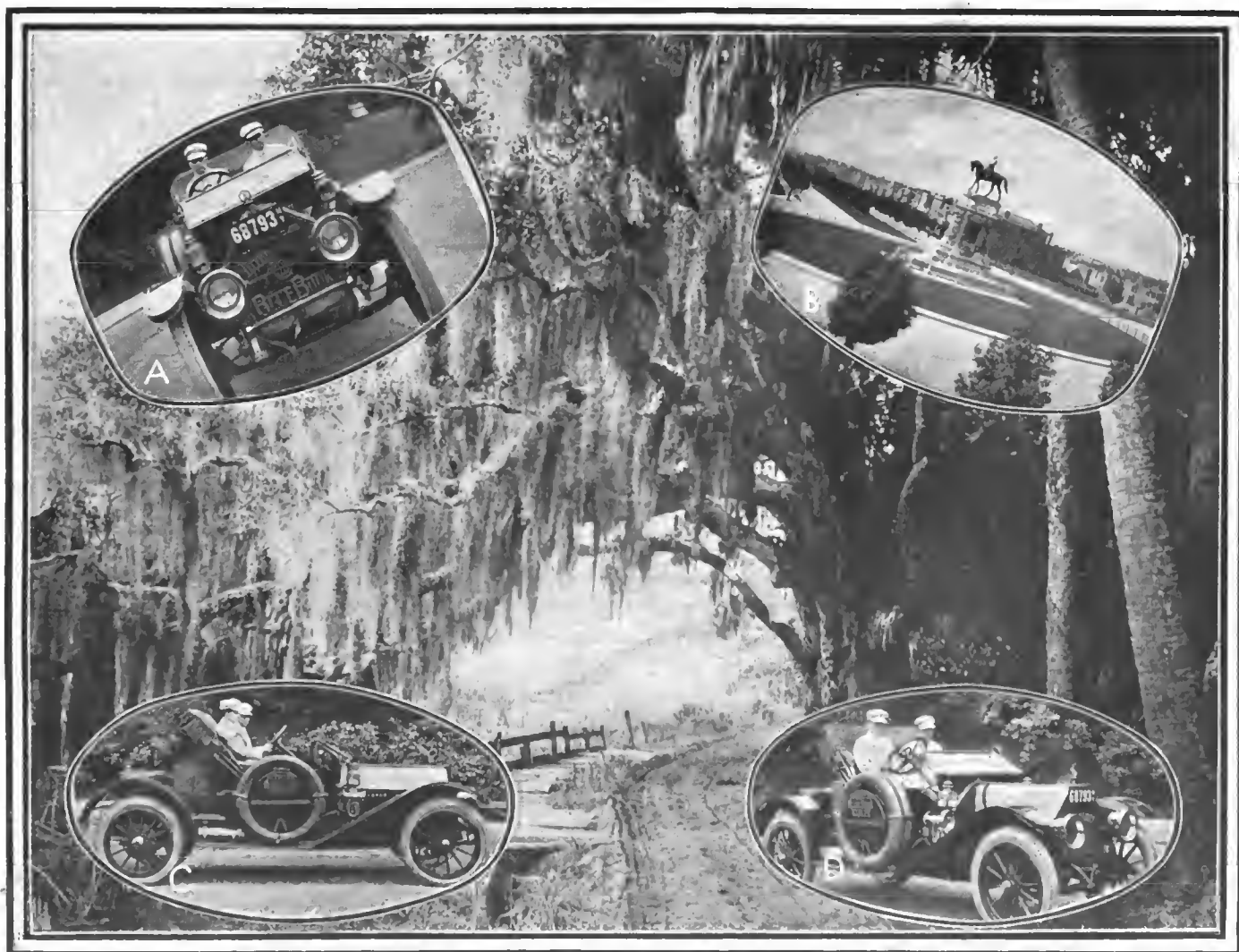

Three new Blue Book Good-Roads surveying cars started this week on a 75,000-mile mapping tour



# Cause and Cure of Motor Car Noises

## Knocks, Squeaks, Hisses and Pops That Worry

*Detailing some of the common causes of noisy operation of the automobile's mechanism, and how to locate the components at fault, Victor W. Page, M.E., instructively discusses them from the viewpoint of the owner-driver, and suggests remedies for each of the annoyances. Taking the various systems of the automobile in turn, he points out the causes of noise in the respective parts and tells how they may be overcome, concluding with an interesting paragraph or two on hard-to-find knocks and squeaks that are due to unusual causes.*

ONE of the most annoying conditions that may become manifest in connection with automobile operation, and one most difficult to detect by the average motorist, is that of noisy action while the mechanism is in use. This is especially worrisome because of the difficulty which obtains in tracing the noise to its source.

It is hardly possible to build a motor vehicle entirely free from noise, but it is not difficult to keep the mechanism so well adjusted and lubricated that the most distressing sounds will be entirely absent and only minor clicks, such as result from the clearance between the valve operating plungers and the valve stems, or the hum of the motor timing gears, will be noticeable. Some knocks presage rapid deterioration and untimely end of the part, indicating its distress, while others of equal magnitude do not foretell anything of import, being caused by looseness of some relatively unimportant part.

To be able to tell when a portion of the mechanism is defective by the sound is a knack that can only be acquired by experience, but some general rules can be given so the average motorist may become sufficiently expert to distinguish between the various noises, locating troubles by systematic search rather than the haphazard manner in which they are usually sought by those who do not have much mechanical experience.

Considering the power plant first, we find that the sounds commonly heard may be divided into four classifications, namely, pounding or knocking, squeaking or grinding, hissing or puffing and popping. Knocking is usually due to wear in bearings or looseness between other revolving or reciprocating parts. Squeaking is usually produced by contact of dry metals which are in motion relative to each other, and is an almost infallible indication of faulty oiling. A hissing or puffing sound always indicates a leak of gas under pressure, while a whistle generally shows that gas is blowing by a loose packing, or air is inspired in the engine at some point that should normally be tight. Popping noises may be evidenced at the carbureter or muffler, and are usually produced by conditions which make for imperfect combustion or slow burning of the charge.

The bearings which deteriorate soonest are those of the connecting rods; both the journals at the crankpin and those at the wristpin will wear in time even if well lubricated. The wristpin bearings have but a limited movement as compared with those at the lower end of the connecting rod; the pressures are great, the temperature high and the lubrication is not so positive as at the crankpins, so these bushings often fail before those of the lower end become loose.

Any looseness of the bearings will be manifested by a sharp metallic knock, though pounding does not always indicate that these parts are in poor condition. Deterioration of the connect-

ing rod bearings is detected by removing the side plate of a one-piece or barrel-type crankcase or the bottom of a two-piece engine base and then endeavoring to move the rod up and down by the hand. Any play denotes lost motion, and, while a certain amount of movement along the horizontal axis of the shaft is permissible, there should be no large amount of vertical movement. The main bearings may be tested by raising the shaft by means of a jack placed under the flywheel or a lever fulcrumed upon the frame side member if the construction permits. If a lifting jack is utilized it should be so blocked up that the lifting ram is brought in contact with the outer periphery of the flywheel or one of the throws of the crankshaft, and any movement of the shaft will be clearly indicated by that of the operating lever.

If the pistons have become worn and the cylinder bore is greater at those points of the piston travel where the side pressure against the cylinder wall due to connecting rod angularity has been greatest, a considerable side movement of the piston is possible, the resulting pound being very much the same as though a bearing was loose. Another very common cause of knocking is a carbon deposit in the combustion chamber which tends to produce early firing or preignition of the compressed charge. This condition is due to lubricating systems which deliver the oil in such copious quantities that portions of it work up past the piston rings and burn because of the intense heat of the explosion. The deposit becomes incandescent at certain points and explodes the gas before the electric spark which normally performs that function takes place. Another way in which carbon deposits may cause preignition is by reducing the compression space in a motor which normally has a high compression. An eighth of an inch deposit on the piston top and a corresponding amount in the cylinder head would decrease the compression space by a quarter-inch, and thus even a very slight variation from the normal condition might cause early ignition.

An uncommon cause of knocking is due to the flywheel loosening on its shaft, although the later methods of fastening make this an unusual occurrence. On many of the older engines the flywheel is secured to the shaft by a large Woodruff key, or a gib key. If this is not fitted with extreme care the flywheel loosens on its fastening and the reduction of width of the key or the augmented size of the keyway produces a certain amount of lost motion, which results in a pronounced knock every time the flywheel comes in contact with the key. Even when the flywheel is bolted to a flange forged integral with the crankshaft, there may have been some carelessness in fitting the retaining bolts or in machining the bolt holes, which would permit the fastening means to loosen and the flywheel to shake and thus cause a metallic knock.

Loose cams on the camshaft, loose timing gears and worn gear teeth often cause pounding. Deterioration of the valve-operating mechanism generally produces a rattle, though if strong valve springs are fitted any lost motion in the timing gears, cams, valve plungers and even in the valve stem guides will make pronounced knocks, which become greater at higher speeds. The camshaft bearings, when of the plain bushing type, may wear and the lost motion produce noise, while many of the minor bearing points, such as the small pins of the overhead valve mechanism, loose tappets and rocker arms, or looseness of the roller at the bottom of the valve-operating plunger will in the aggregate produce considerable rattle, especially at higher engine speeds and with strong valve seating springs.

A severe pound is sometimes traced to faulty motor bed



retaining bolts, which allow the crankcase to shake in the sub-frame or on the main side members. The shaking loose of the cylinder retaining bolts or nuts will cause a pronounced knock, and usually results in a broken cylinder flange if not promptly remedied. Sometimes a piston may be striking the end of the counterbore or shoulder left in some cylinders after machining; this condition often obtains when thin oil-retaining packings are inserted between the engine base and the cylinder flange instead of the thicker ones formerly used after an engine had been overhauled.

A bent or sprung crankshaft will impart a certain side shake to the connecting rod that will cause forcible contact between the sides of the wristpin bushing and the piston bosses during a certain portion of the revolution and bring the sides of the crankpin bearing against the crankwebs sharply enough to produce noise at other times. If there is considerable end motion of the crankshaft it may result in an irregular knock. The end of a connecting rod may hit a bolt or screw projecting into the case, or a connecting rod or main bearing cap or retaining screw become loosened enough to permit considerable play. A wristpin may be loose in the piston bosses, and there is always the possibility of some small parts, such as set screws, nuts, washers, split pins, etc., coming adrift and falling into the crankcase in such a position that some of the revolving parts will come in contact with them at times. In many engines of the single-cylinder type the counterweights fastened to the crank throw opposite the crankpin to balance the reciprocating parts may be-

come loose on the retaining bolts and cause a severe knock. This condition demands immediate attention, for if one of the balance members becomes unfastened the crankcase is doomed.

Sometimes, when the spark plugs are placed over the valves a long shell member may be inadvertently substituted for a shorter plug and a pronounced knock may result because of the contact of the valve head with the plug bushing. This should be avoided and care taken to use only plugs of proper length, because this forcible contact may spring the camshaft or bend the valve stem. A timing gear with worn teeth and loose upon its driving key may cause a combination of sounds that will lead one to believe that the end of the motor is near, while a broken ball or roller bearing will cause a combination knock and grinding noise that is hard to mistake for anything else.

Anything that will cause the motor to become excessively hot will produce a knock, and when overheating is due to poor oiling there will be squeaking or grinding noises denoting dry bearings as well. Failure of the cooling system will cause the motor to become so hot that the charge preignites and one has the same condition and sound as though the interior of the combustion chamber was full of carbon.

Another common sound that indicates faulty power plant action is a sharp hiss, and this can usually be traced to a leak in the cylinder above the piston top. The petcock used to relieve the compression and for priming may have jarred open, and it is not an uncommon occurrence for the shut-off valve part to drop out of the seat and allow the gas to escape. To remedy this

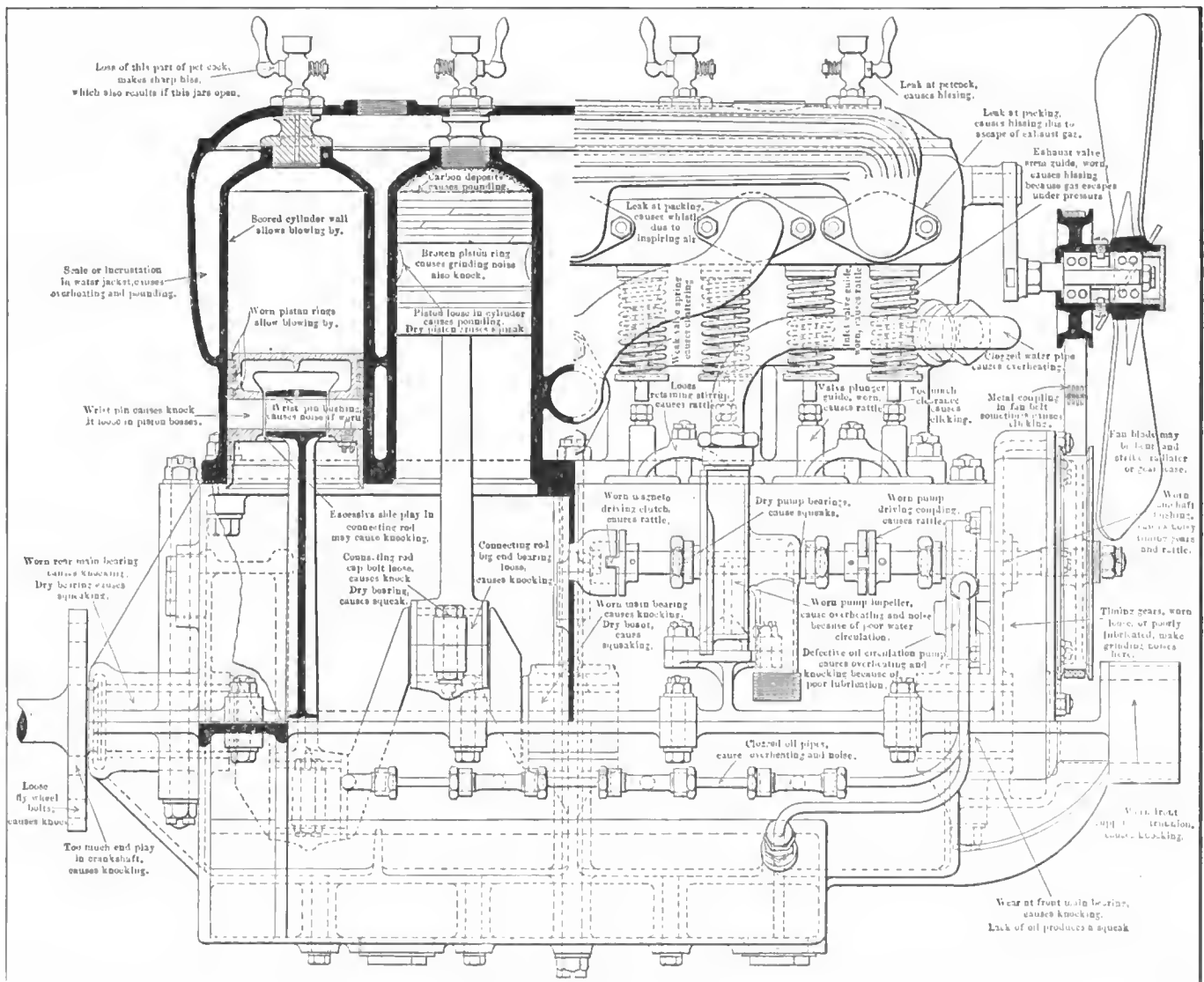

Longitudinal sectional view of a four-cylinder motor showing the relation of the various working parts with a view to the discovery and prevention of noises

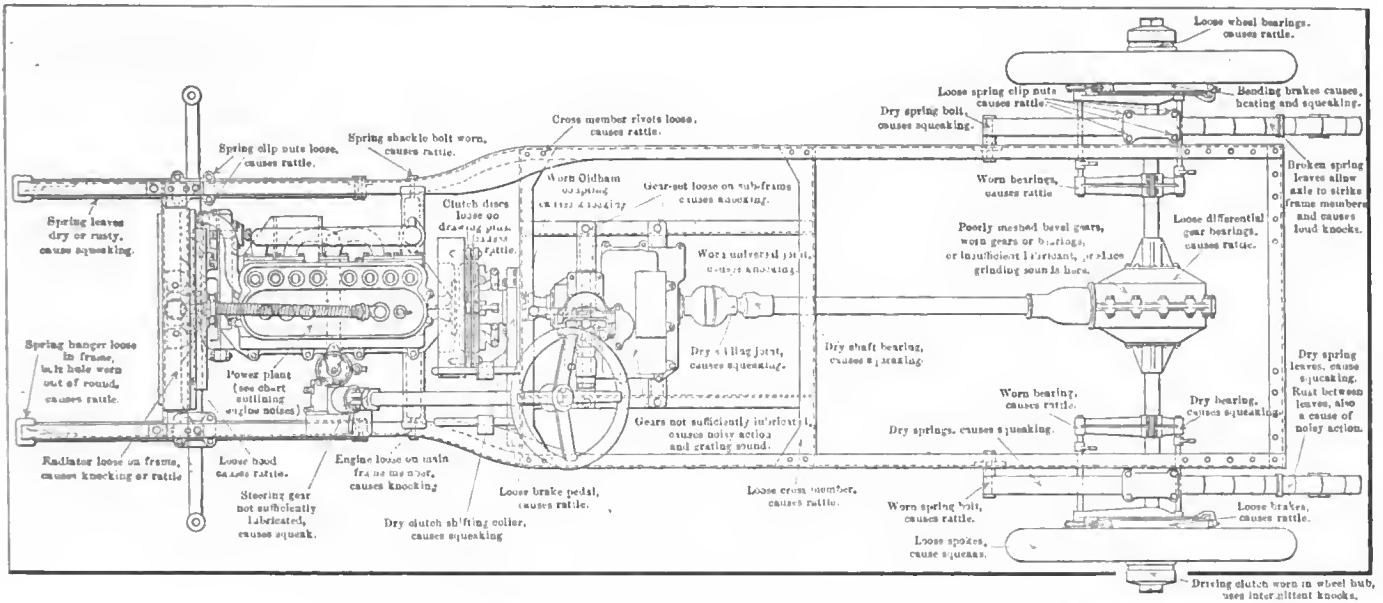

Plan view of a chassis showing by means of notes the probable location of noises

a plug of wood may be made and driven in, or a repair extemporized out of a small bolt and a couple of washers if the missing part cannot be found in the under pan. A hiss may also be caused by a broken spark plug gasket or a faulty packing under one or more valve chamber caps, and a defective exhaust manifold gasket or lost retaining bolt that allows the gas to escape will also produce a hissing sound. A whistle is caused by escaping gas around a loose packing that acts as a reed. This sound may be produced either by inspiration or exhaust of gas and therefore any loose packing on either the inlet pipe, the exhaust gas conductor or the engine base may produce it. A small crack in either of the gas conductors will also produce a whistle—in the inlet pipe when air is drawn in at that point, at the exhaust when the inert gas is discharged through the very small opening. Leakage through worn inlet or exhaust valve stem guides will also cause hissing.

When a squeaking noise is heard look after the lubrication system. The main bearings may run dry, or the level of oil in the engine case may be so low that the interior of the engine is deprived of the oil necessary to insure smooth and continuous operation. Find out the cause of the squeak at once, for if bearings are run without proper lubrication they will burn out if of white metal or babbitt or seize and cut the shaft very badly if of bronze. Dry cylinders will become scored and the process of reboring that is necessary to restore their efficiency is much more costly than the price of oil enough to insure proper oiling for several years. Impurities in the oil may cause grinding sounds by getting between bearing surfaces, and parts that fit too tightly cause a grind or squeak even when they are copiously lubricated.

A wheezing and scraping sound may be traced to the flywheel scraping against a projecting piece of the underpan in contact with it. A slight clicking sound may be due to the fan blades striking the radiator. A broken wristpin will often cause both pounding and scraping sounds, the knock because of the lost motion in the bearing, the grinding sound because the end has worked out and is bearing against the cylinder wall.

A broken piston ring often causes a scraping sound, as does a stuck piston ring which cannot move in its groove because of carbon accumulations behind it which force it against the cylinder wall. A very sharp squeak has been traced to a dry contact blade in the timer or contact breaker of a magneto; a dull squeak has been finally located in the timing gear case, being produced by the rawhide shrouding of one of the large gears swelling out and coming in contact with the timing gear case cover.

Another intermittent knock and grinding noise is sometimes caused by the governor weights striking the timing gear case

cover when the engine was suddenly accelerated, and remaining in contact with it when the engine was run at certain speeds. When the motor was running slowly the weights were held in position by the springs, but just as soon as the speed was increased the weights flew out against the cover and produced a knock, afterward grinding as long as the speed was maintained that kept them in contact with other metal. If the shifting collar of a clutch is not properly lubricated it will squeak in a very pronounced manner, while wear in the driving connection will cause a sharp knock every time the clutch is released or engaged, as well as every time the motor speed is changed or regularity of torque interrupted.

Gearsets are apt to be noisy after they have been in use for some time—the planetary type on the low speed and reverse ratio, the sliding gear forms on all speeds. The design of the planetary gearset and the high speeds at which the small gears revolve tend to make for noisy operation even when the gear is new, and this condition is augmented considerably when it has been in use for some time. If sliding gears are properly made and handled there will be no undue noise, but as soon as the gear teeth wear, however, and the shaft bearings lose their correct adjustment, the grinding on the lower speeds will be very objectionable and a certain amount of noise will obtain even on the high speed, as the lay shaft and main driving member gears are always in mesh. When the keys and splines wear so that the gears are not rigidly held to the shafts the noise due to the teeth being worn out of correct pitch will be intensified. If the bearings lose their adjustment or become worn, the center distance between the gears will be changed and noise result because of improper meshing. Metal particles in the lubricant often cause grinding, and unsuitable oil, or a lack of lubricant, may result in noisy operation even if the gears are not worn unduly.

In some types of selective gearsets the amount of sliding movement necessary to engage any of the gears is very slight, and but very little lost motion is required to permit the gears to come in contact at the tooth edges while out of engagement and cause grinding or an intermittent knocking. Examine the locking balls or spring-actuated plungers that keep the parts in place and prevent motion of the disengaged members and see that they are functioning properly. If annular ball bearings are used, they are liable to make a clicking noise if there is a damaged ball or broken separator and grind if there is foreign matter in the races. If bearings and gears appear to be in good condition and the lubricant has proper viscosity and is clean, and still there is an objectionable grinding noise on the lower speeds, it is possible that one of the shafts is sprung and the gears are not meshed properly at a certain portion of their revolving movement.

Chain drives, unless properly encased and lubricated, are apt to be noisy except when new, and even then there will be a "singing" sound at high speeds. The grit and oil that collect on exposed chains cause the links to wear out of pitch, and, as the sprockets depreciate at the same time, it is not long before the drive is quite noisy. If the sprocket teeth become hooked and the chains are adjusted too tight they will "snap," while if too loose the chains will "slap" as well as grind. The small driving sprockets on the countershaft sometimes become loose on their fastenings, and a knock very similar to that of a loose bearing is heard every time the continuity of the drive is interrupted.

A very common noise emanating from shaft-drive rear axles is a grinding sound, which often becomes greater at high vehicle speeds. This is usually due to wear of the bevel driving gears; deterioration of their supporting bearings; lack of proper lubricant; foreign matter in the oil and very often to poor adjustment. Bevel gears will produce a harsh grinding sound when meshed too close together, and, on the other hand, if not engaged sufficiently there will be a rattle. A very common cause of rattle is loosening of the driving means at the wheels, especially on full floating axles where the hub is driven by a jaw clutch attached to the end of the axle shaft. If these become worn so there is lost motion between the driving dogs and the slots machined to receive them, the play will be evidenced by knocking every time the continuity of drive is interfered with. On some of the lighter live axles the shafts are supported on plain cylindrical roller bearings which bear directly on soft steel shafts and in a soft steel tubing axle housing. These cut through into the shafts and also remove considerable metal from the tubing interior. When the play becomes great enough there will be a pronounced rattle whenever the car is driven over Belgian block pavement.

It is not uncommon to trace a squeak to a dragging brake band, usually one of the internal brakes which has become covered with a deep enough accumulation of dust or grit to keep in contact with the drum. Poorly adjusted brakes will also cause the same condition, but care should be taken not to have these members too loose or there will be a rattle instead of the squeak.

A loud knocking is often traced to worn universal joints, which have so much lost motion between the cross and the driving pins, and often between the yokes and the center member that the parts are brought into forcible contact with each other at every movement of the rear axle that causes even the slightest variation in driving shaft angle. This is especially true of unprotected universal joints, the dirt that works into the bearing surfaces causing rapid wear and considerable noise. In this connection it is well to call attention to the pronounced knocking, very much like a worm engine bearing, that results from driving torque or radius rods when they show wear at the points where they are fastened to the frame or axle.

Most of the components comprising the chassis assembly are held to the frame by bolts and nuts instead of rivets because of

the necessity which sometimes arises for their removal for repairing. It is not infrequent that common machine and carriage bolts are used as fastenings, and as they loosen they naturally tend to produce a rattle. Rivets sometimes loosen and a sub-frame or cross-member supporting some heavy member such as the power plant or gearset becomes loose and produces noise.

The brake operating rods and various links of the control system are sometimes carried on the frame in such a way that they come in contact with the frame members and produce a rattle. Very often these are passed through holes in the frame members and squeak because of the dry metallic contact whenever they move longitudinally and rattle with every frame movement. Lost motion at spring shackles causes sounds that are not pleasing and dry springs produce squeaks that are distressing and very easily prevented. When spark-and-throttle control shafts pass through the center of the steering column, these may become rusted slightly or not have sufficient oil, and every time the steering wheel is turned or the engine speed varied a squeak is heard that is often hard to locate. Various points on the front axle may wear or get out of adjustment and produce their distinct little rattles that contribute to the general din. The tie-bar and drag-link yokes or ball joints may have considerable lost motion, the steering knuckles may be loose on the yoke pins and the ball bearings may be worn or out of adjustment.

Noises are sometimes located in queer places that one would never suspect. For instance, a pronounced squeak was found due to the opening of several of the joints on the sills of a wooden body after all points of the mechanism had been carefully gone over with an oil can. A knock that was searched for in vain in the engine was finally located at the gasoline tank, which was adrift on the frame; another that suggested loose connecting rod big ends was eventually discovered in the muffler, where a baffle plate had become loose on all its retaining rivets except one at the top, which permitted it to swing back and forth like a pendulum at every impulse of the motor, and thus produce a rhythmical knock usually attributed to a defective engine bearing. A dry water pump stuffing box produced a squeak, while a clicking noise that was searched for in vain for several days was discovered in the fan belt, which had a metal fastener that produced a little metallic knock every time it went over the fan pulley.

Every point where movement is possible should be well fitted and have a minimum of lost motion; the mechanism must be kept clear of the abrasives that work into the bearing points and produce untimely deterioration, and all joints, no matter how unimportant, should receive oil. All loose rods, wires and parts should be firmly fixed; every nut should have some kind of positive securing means to insure against loosening by vibration: pipes should be kept tight; broken packings and gaskets should be replaced as soon as they give evidence of leakage, and, above all, the engine bearings should be kept adjusted to that point where the power plant will be silent in action.

## In the Fitting of the Top

### One or Two Points That Are Generally Overlooked

*George J. Mercer offers a few suggestions to the automobilist who desires a top fitted to his car, nor would it be out of place to observe that the top maker would be the proper authority to advise the owner to get a good top while he is about it.*

**W**HAT the public sees when an automobile goes by is everything that intercepts the line of vision, including the soiled appearance of the fabric of a top, if the ma-

terial used therein is of the class that picks up dirt and holds it in the mesh of the weave. What the owner of the automobile experiences includes a most unpleasant sensation if the top soils readily and belies the quality of the car despite effort. It is not uncommon to see fine examples of automobiles sporting tops that cost enough to be good, but it is a great misfortune that purchasers of automobiles put in too much time discussing the several phases of their ideals to the high disregard of the kind of material that is used in tops and of the fact that the ironing

of a car for the top is something to be given serious consideration, and referring to Fig. 3 of a side elevation of a top fitting on a fore-door type of automobile it is pointed out that the iron, if it is placed at E, is in exactly the right position to be struck against by the elbow when the driver of the automobile slides the gears or puts on the emergency brakes, and it is not too much to say that an interference of this character at a critical moment may be the foundation of a serious accident. But if the iron is placed at F instead of at E there is nothing to prevent the proper working of the top, and the occupants of the front seat will have a clear view of the surroundings without having to peek around an interfering member. Moreover, the idea of interference during the sliding of the gears or the working of the emergency brakes will be done away with.

Still another point that is sometimes overlooked is coupled with the idea that the head room D does not have to be so very much since it is customary to hold to a stooping position during the operation of getting into a car, but there is no reason why the diagonal support of the top should be so slanted as to interfere with the head room at the point G. It is certainly possible to so locate the iron H that the diagonal brace at the point G will come in the plane of the back sill of the rear side entrance.

In the three figures given there is ample opportunity to observe the relations as they hold between the side elevation, top and rear view. Success in the fitting of a top begins with the proper placing of the irons and referring to A and A' in Fig. 1, the rear top irons are indicated, showing how they are fashioned to support the top when when it is folded down. At A the fabric is cut away and the iron is shown in its position far enough to the back so that the socket is level with the widest part of the seat trimming, measuring about 27 inches from the center line in this example, and referring to A' at the right side of the body this iron is shown as H in Fig. 3, occupying the forward position, in which the distance from the center is approximately two inches greater than the same distance for the back irons. This increase in distance is due to the placing of the front irons H at the widest point of the body, and it is suggested that the body designer should have in mind the suitable location of the irons at the time of laying out the body.

Proper clearance should be given between the inside of the bow when down and the outside of the socket iron at A'. and experience seems to show that a distance of four inches will be sufficient, making the top clear at A'. In selecting tops for the various makes of automobiles the observance of a due measure of clearance may dictate the use of bent bows in some cases, but it is well to guard against the outward swelling of the bows too much, and here again there is opportunity for the designer of the body to settle the problem of the fitting of the top, avoiding tight situations, catering to appearance and utility at the same time.

There are two broad considerations that are present in the fitting of tops, one of which has to do with the top when it is up and the second point deals with the top when it is folded down. Strange to relate, most tops give trouble when they are in the folded-down position. This is due to the fact that the irons are not placed far enough back to carry the load without putting undue work upon the bows, and this difficulty is accentuated by selecting tops that are higher than there is any occasion for having them. The illustrations here given show by measurements indicated just what can be done in

the matter of fixing clearances and arranging for the proper support of the weight, and if these matters are properly attended to the remaining considerations will have to do with the proper selection of the bows and the fashioning of the irons, having in mind the idea that the irons should be securely bolted to the frame of the body, and for the rest it is a mere matter of picking out a good grade of fabric that will match the outward appearance of the car, keep out the rain and resist dirt.

It would be a step in the right direction were it against the law as it is against honesty to apply false descriptions to the fabrics that are used in this class of work. It is marvelous what a large number of fabrics there are that are called mohair without due license. It is also true that the mohair used in many instances is too thin to do good work. The purchasers of automobiles should specify genuine mohair weighing about eight ounces to the yard, if this type of material is to be used in a top, and there is no reason why an Angora goat should be discriminated against by having imitation mohair foisted upon a purchaser simply because it is difficult to tell from appearance the difference between genuine mohair and "lustre wool." It is not the purpose here to contend that lustre wool fabric is too poor to use in a certain line of work, but it is proper to say that lustre wool fabric should not be sold to a purchaser as genuine mohair.

The main difference between genuine mohair fabric and that of wool is represented in the better life of the mohair, the greater protection it affords and the further fact that the hard wire-like thread of the mohair works into a fabric that will not hold dust, there being nothing for the dust particles to cling to. Beyond selecting the types of fabric that will afford the requisite protection and retain a good appearance for a long time there still remains the necessity of protecting the top against accumulations of dust by having the cover properly fitted, especially at the front end, and the idea that anyone should put up with a "baggy" looking affair as a substitute for a real top is too ridiculous for serious consideration.

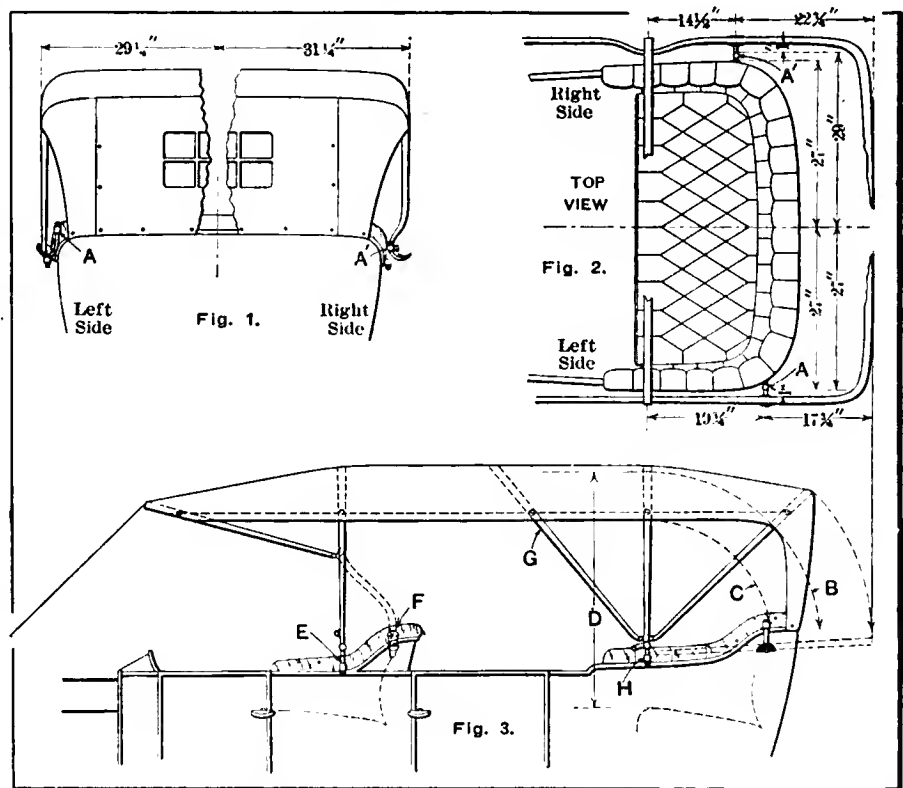

Fig. 1—Rear view of a properly fitted top showing the positions of the irons at the back and side  
 Fig. 2—Plan of the top showing clearances of the bows in the folded down position  
 Fig. 3—Side elevation of the top in the up position suggesting elbow clearance by placing the iron at the front seat far enough back to properly serve the purpose

## When Judgment Whispers Don't

- DON'T overlook the damaging effect of extreme conditions of heat upon rubber tires.
- DON'T drive too fast on a hot day; even automobiles experience a depressing effect if the weather is warm.
- DON'T stand the automobile exposed to the blazing heat of the sun; it will blister the finish.
- DON'T use light body lubricating oil if it must resist the heat of a Summer's day and do its work besides.
- DON'T overlook the sensitiveness of a machine to heat and cold; expansive effects must be taken into account.
- DON'T tax the adroitness of a good automobile in the production of dust to the annoyance of an antagonist.
- DON'T try to make your neighbor eat dust; if you think it is a healthy diet take your fill of it.
- DON'T interpret liberty as meaning that you have the right to practice the artifices of a road-hog.
- DON'T pass a brother automobilist on the road if he gives a distress signal; you can well afford to stop and see what he wants.
- DON'T annoy the blue-coated guardian of the peace; he will not care to sprint as fast as your automobile may be forced to go.
- DON'T practice antagonism when the weather is warm; the judge might give you a limit fine.
- DON'T miss the opportunity to splash water on the tires if the day is hot; it will cool them off and add materially to their stamina.
- DON'T embarrass the motor by running on a retarded spark; the radiator will catch the disorder also if this practice is indulged in.
- DON'T poke fun at a brother automobilist if you catch him trying to pump up a tire with a toy pump.
- DON'T attempt to crank an overheated motor without approaching it in due and diplomatic form.
- DON'T crank with the right hand if you can do the work with the left.
- DON'T push down upon the crank—it is safer to pull up.
- DON'T forget to retard the spark before cranking.
- DON'T count too much upon the unconstitutional features of bungling legislation—your curiosity might cost you more than a dollar per pound.
- DON'T start out with a pint of lubricating oil and the promise that you will get some more at a convenient garage—a burned-out crankshaft bearing might greet you before you get to the garage.

DON'T forget that the police interpret the law, and also decide its fine points.

DON'T employ the languid method of cranking a motor—it might get mad and inject some ginger into you.

## Antipodean Automobiling

*Australian motorists are much interested in the question of self-starters, several new systems having been evolved during the past year. The automobile is an aid in opening up the country. Australia affords touring ground which in point of interest and scenic beauty is second to none in the world.*

AUSTRALIA is manifesting deep interest in what automobilists term "the direction of the self-starting motorcar engine," as revealed by the introduction of several new systems evolved during the past year. The engines include methods for compressing carbureted gas into the cylinders by artificial means, in order to secure an initial charge; methods of forcing the engine to turn past one or two firing points by means of compressed air, and also methods purely mechanical in their nature.

There is an estate of many thousand acres of wild and wooded, roadless land in Australia, whose owner has just received ten automobiles from England. He had these machines constructed after his own designs. These contained numerous stipulations, especially these: The machines were required to be equipped with gears for stationary work; be provided with a winch for hoisting or pulling them out of soft ground; have a sufficient clearance to negotiate several feet depth of water; and be capable of going at a reasonable speed.

The Upper Murray Mountain in Australia affords innumerable attractions for automobilists, rugged, ragged and danger-wrought though this mountain is. The route is from Wodonga to Talgarno, passing through Jingellic, Walwa, Tintaldr, Gorryong, Wabba, Berringama, Koetong and Tallangatta. Not alone Australians, but also around-the-world tourists take advantage of this wild, romantic, mountainous highway, many parts of which have been rebuilt expressly for automobile travel.

The Motor Car Act now in force in Melbourne carries with it the obligation that each driver's license shall bear the endorsement of a Police Court Magistrate on the reverse side. One captious critic, chafing under what he declares to be an unfair custom, says that "licenses thus disfigured are standing evidence, as far as they apply against the efficiency of the holders, as motor car drivers, who even were they nominally at fault in the first instance may now be ranked among the experienced and most careful drivers."

## The Effect of Silicon on Steel

By E. F. Lake, M. E.

*Silicon in steel is as beneficial in its effects as silicates are undesirable, and this article treats of the correct method of incorporating the metalloid in steel and of repelling silicates. By means of this ingredient corrosivity of iron and steel may be overcome and the formation of blow-holes thwarted, but a considerable amount of care is necessary in the manufacturing of siliceous steel using either silicon or its alloys with iron and manganese in exact proportion in order to avoid destroying the good qualities of silicon steel.*

THE wide application of silicon was only begun when the electric furnace made it possible to obtain ferro-silicons that were rich in silicon. The importance of this metalloid in metallurgy has shown a steady increase since that time, in that its addition to iron, steel, aluminum and so forth has proved to be very beneficial, and doubtless other benefits from its use will be discovered in the future.

Silicon forms 27.21 per cent. of the earth's crust and is the second most important element, oxygen being first. As it has a great affinity for oxygen it occurs chiefly in the form of silicon dioxide, SiO<sub>2</sub>, which is commonly called silica. It is never found



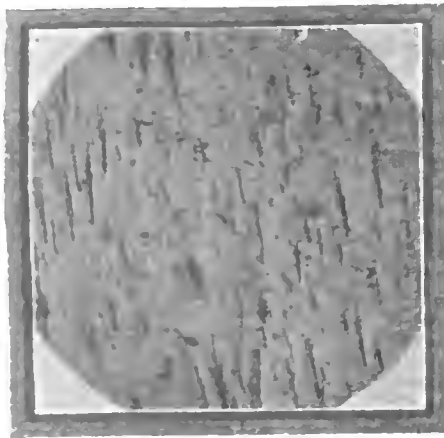

Fig. 1—Fibrous structure of silicon steel, magnitude 300 diameters

Silicon is a non-magnetic metalloid, while iron constitutes the typical magnetic metal. Each increase in the percentage of silicon that is added to iron decreases its magnetic attraction. When the silicon reaches a high percentage it makes iron practically non-corrosive and thus it has been possible to use irons containing from 15 to 20 per cent. of silicon in the construction of drainage pumps such as are used around salt water, and also for the bilge pumps of ships. At these high percentages there is a distinct antagonism between the silicon and carbon and each increase in the silicon's percentage is accompanied by a diminution of that of the carbon. With this decrease of the carbon numerous cavities are formed that are filled with the graphite dissolved from the carbon in the iron during fusion. The carbon is subsequently almost entirely separated while the metal is cooling.

The effect of silicon on steel is not yet thoroughly understood. When Bessemer steel has silicon left in it, it indicates that the metal had been blown too hot. Such metal is apt to be brittle. To get the best results in steel the silicon should be eliminated as much as possible when purifying the bath and the definite quantity required should be added in the form of ferro-silicon or ferro-manganese-silicon. This gives a much different effect from that of silicon left in during the process of manufacture. When silicon is added to steel in a manner that will cause it to enter into solution as silicide, it confers upon the metal valuable properties, but when it forms a silicate it is injurious in many ways, even to the point of being dangerous. This occurs as the silicates of iron, manganese, etc., but these usually dissolve into each other and go off into the slag; although manganese-silicate probably causes more failures in the steel than is generally supposed.

Silicon is one of the best elements with which to prevent the formation of blow-holes in steel, as it has a great affinity for oxygen and seizes this wherever found whether in the form of gases, oxides or dissolved oxygen, and carries it off into the slag. It thus makes the steel harder and tougher and better able to withstand wear and crushing from continual pounding. One steel maker discovered that if the percentage of manganese plus 5.2 times the percentage of silicon was made to equal 2.05, the metal would be entirely free from blow-holes, but the pipe would be large. If the total was made to equal 1.66 per cent. the pipe would be smaller and numerous minute blow-holes would appear, but not enough to harm the steel for most uses. It was also found that 0.0184 per cent. of aluminum would have the same effects as 1.66 per cent. of manganese and silicon.

In the Bessemer converters silicon increases the temperature of the bath and hence a pig iron that is low in silicon will cause the blow to be shorter than if it were high. At the end of the blow 0.2 per cent. of silicon is added to rid the bath of gases. In the crucible process the steel absorbs silicon during the "killing" and thus becomes sound by throwing off the gases. Too long "killing" makes the steel brittle, owing to its absorbing too much

in the free state in nature, but besides the silicon dioxides forms silicates in combination with oxygen and some metallic elements. Silica neutralizes every base it comes in contact with when molten, and all metallurgical slags are the silicates thus formed. For steel making the silicon has to be separated from the oxygen of the silica and united with iron to form ferro-silicon.

silicon, the graphite crucibles usually used in this country give up more silicon than clay crucibles, and for this reason allowances have to be made when charging.

When quenching steel the influence of silicon is similar to that of carbon in many ways. To some extent it neutralizes the injurious tendencies of manganese. The resistance to shock of silicon steels in the direction of lamination is remarkable owing to their extremely fibrous formation. They have practically no resistance, however, in a direction perpendicular to the laminations. They are thus especially adaptable to the manufacture of leaf springs. This fibrous formation gives the appearances that are shown in Figs. 1 and 2 when the steel is examined under the microscope.

Up to about 4 per cent. of silicon each increase in the percentage of silicon in steel slightly raises the tensile strength and lowers the elongation and reduction of area. The tensile strength increases about 80 pounds per square inch for each 0.01 per cent. of silicon, but beyond 4 per cent. a weakening seems to take place unless the manganese is high. Silicon steels will show very low shock resistance whether annealed or quenched, unless they have a high manganese content. With a silicon content of 0.20 per cent. the tensile strength is increased about one-third more than it would be with 0.01 per cent. of carbon.

With few exceptions the steels that are now used in automobile construction contain from 0.10 to 0.30 per cent. of silicon. In place of carbonized gears commonly used in the transmission case, a few motor car builders used a silico-manganese steel that contained about 2 per cent. of silicon, 0.70 per cent. of manganese and 0.50 per cent. of carbon, with the phosphorus and sulphur below 0.40 per cent.

Hard tool steels that contained slightly less than 1 per cent. of carbon have been made with from 1 to 2 per cent. of silicon and these have been used quite successfully. Steels have also been made for several purposes that had a silicon content as high as 5 per cent. With a silicon content higher than this steels have found very little use. When the silicon content is below 1 per cent. silicon ceases to have an influence on quenching and the magnetic property of iron is not decreased to any appreciable amount, hence such steels are not mentioned as silicon steels.

**POINTERS CONCERNING ACETYLENE LAMPS**—Copper tubing is considerably used for piping acetylene gas to the burners, but it is liable to erosion by the gas, and standard 1-8-inch gas pipe is better and lasts longer. The gas bag and rubber lamp connections should be kept clean and not painted, as is often done to correspond with the car, as paint rots the rubber, with the result that it is soon unserviceable and must be replaced. When the rubber is to be washed, only water should be used and it should be carefully dried before putting in service again.

**HOW CAR OWNERS MAY "TURN AN HONEST PENNY"**—Some enthusiastic English people are in favor of devoting the automobile to a unique use, as an endorsement of the proposition of "a lady in reduced circumstances," namely, to put her own private car at the disposal of parties desirous of attending at-homes and after-theater parties. Of course, such obliging service would be done "for a consideration."

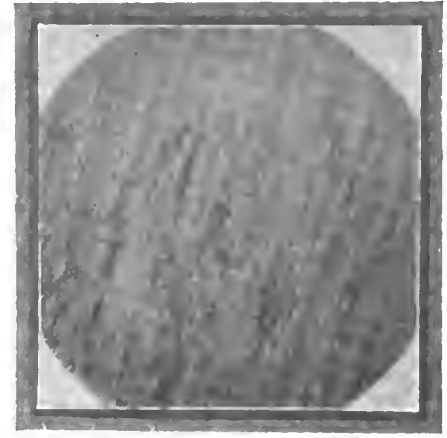

Fig. 2—Fibrous structure of silicon steel, magnitude 300 diameters

## Axle Shows Signs of Sagging

Editor THE AUTOMOBILE:

[2,735]—I noticed a sketch in your paper recently with reference to axle sagging, and it tallies with some trouble I have had. The rear wheels do not run true and it seems that the casing has taken a slight set. Would it be possible to put the matter right by fitting a tie rod? How is this attached?

The method of attaching the tie rod is shown in Fig. 1. A bracket must be fitted to the casing *C*' and the tie rod slipped through the hole and a nut *N* fitted each side of the bracket holding the rod in tension. Even when these rods are fitted drivers do not make proper use of them. Owing to the bending strain that is imposed on the metal it tends to stretch slightly and this must be taken up in the adjustment. In most cars provision is made for the attachment, but in case it has to be fitted afterward the bracket may be made in two halves and bolted over the casing *C*'. In addition it should be soldered or brazed.

## A Most Unpromising Undertaking Indeed

Editor THE AUTOMOBILE:

[2,736]—Will you please tell me who is the best party to weld a crankshaft?

M. G. JOLDS.

Oneonta, N. Y.

Considering the fact that the crankshaft broke in service, if it did, remembering also that a welded section is never as strong as an original section, we fail to see any promise in an undertaking such as this. It might be more to the point to get a new crankshaft.

## Put a Baffle Plate at the Open End of the Cylinder

Editor THE AUTOMOBILE:

[2,737]—At times the right cylinder on my 12-horsepower horizontal opposed offset motor sucks in so much oil that the spark plugs foul up every mile or two. Sometimes it will run 100 miles without a particle of trouble, then again will bother for a week and seems to right itself. I clean the cylinders thoroughly very often. Oiling system is automatic splash, amount of oil in tank seems to make no difference.

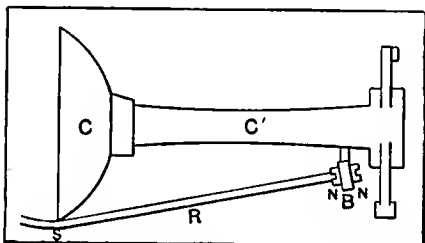

Fig. 1.—Showing how the tie rod is attached to the axle to prevent the same from sagging

## What Some Subscribers Want to Know

Can you suggest any way out of the difficulty?

PERPLEXED.

Worcester, N. Y.

Horizontal types of motors sometimes give trouble of the type as complained of by you, and it is not unusual to fit baffle plates at the open ends of the cylinders, these plates being of sheet iron or aluminum flanged to the diameter of the cylinder with a slot cut across the disc of a size that will permit of the play of the connecting rod. The fitting of a plate of this character is not a difficult undertaking, and it has the advantage of being the certain cure for the disorder.

## Method of Replacing Ball Sockets

Editor THE AUTOMOBILE:

[2,738]—I find that the ball socket of the steering arm of my car has worn considerably. Can I have this replaced without having a whole new part made? The car is not a modern one and I am afraid I shall

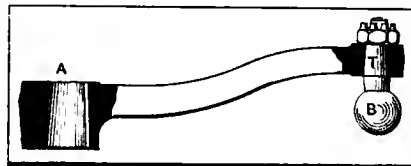

Fig. 2.—Showing how a new ball joint can be fitted to replace a worn one

have some difficulty in obtaining a new part even if I wanted one.

ANCIENT.

Norristown, Pa.

The method shown in Fig. 2 of attaching the ball socket should answer your purpose. It will be noticed that this part represents the drop arm of the steering gear and that the end is made large enough to drill and fit a taper bolt *T* with a ball *B* attached turned out of the solid.

After the part has been fitted it should be case-hardened. The wear you complain about was probably due to the old one not being properly hardened. The joint should be covered with a leather boot filled with grease.

## Wants Information on a Variety of Subjects

Editor THE AUTOMOBILE:

[2,739]—Please answer the following questions through "Letters."

1. In what year did the Franklin engine contain concentric valves?
2. What are the objections to this type of valve?
3. How many Gordon Bennett cup races were run and what cars and drivers represented America?

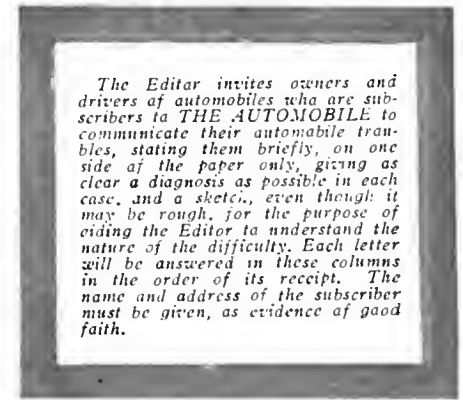

4. What is the horsepower of the Only car?

SUBSCRIBER.

Topeka, Kans.

1. Last year.
2. Nothing.
3. Years 1899, 1900, 1901, 1903, 1904 and 1905.
4. We have no record of a horsepower test of this car.

## A Paste Called "Smooth-on" Will Help You Out

Editor THE AUTOMOBILE:

[2,740]—There are two small cracks in the water jackets on the third and fourth cylinders of my car, through which the water leaks slightly. How can I remedy this? I certainly will appreciate it if you will answer this question in your next issue.

TROUBLE.

Lancaster, Pa.

For many years in foundries and like establishments it has been the practice to mix finely powdered gray iron with chloride of ammonia (sal-ammoniac) to form a paste, which, when applied to metallic surfaces hardens and after a few hours this paste assumes all the characteristics of cast gray iron, of which the cylinders are also made. If you will get a can of "smooth-on" and apply it agreeable to the directions supplied therewith, it will probably lift you out of your present dilemma.

## Method of Withdrawing Jackshafts

Editor THE AUTOMOBILE:

[2,741]—Could you tell me how to withdraw the jackshaft from my rear wheel without taking the wheel off every time? The flange of the hub is extended out and the hub cap fits on to it.

L. W. L.

Atlanta, Ga.

We should suggest you having the end of the shaft drilled and tapped to take an extracting tool similar to the one shown in Fig. 3. By means of this it is possible to

## What Other Subscribers Have to Say

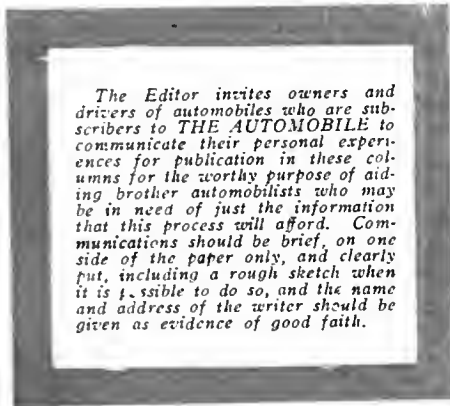

The Editor invites owners and drivers of automobiles who are subscribers to THE AUTOMOBILE to communicate their personal experiences for publication in these columns for the worthy purpose of aiding brother automobilists who may be in need of just the information that this process will afford. Communications should be brief, on one side of the paper only, and clearly put, including a rough sketch when it is possible to do so, and the name and address of the writer should be given as evidence of good faith.

withdraw the shaft without difficulty. It may happen that in the fitting in the shops there are some marks on one of the teeth that engages with the hub forming the driving member and these should be looked for so that they may be replaced in the manner intended by the makers.

### A Trio of Questions

Editor THE AUTOMOBILE:

[2,742]—I would like to ask the following questions through your valuable columns:

(1) What motor is used in the "Mercer" car manufactured by the Mercer Automobile Company of Trenton, N. J.?

(2) What manufacturer was the first to market a six-cylinder automobile?

(3) What cars did the "Correja" defeat in last year's hill climbs?

Newark, N. J. M. H. POTTER.

1. The motor in the Mercer car is of the continental make in Model C, and Mercer make in the M "30."

2. The Stevens-Duryea was probably the first six-cylinder motor.

3. We do not discover a record such as you are in search of as made by the Correja car.

### What Make of Rear Axle

Editor THE AUTOMOBILE:

[2,743]—Being a subscriber to your journal I take the liberty of asking with what make of rear axle is my car equipped. I have noticed that the same make is used on the Halladay, Auburn, Parry and former Overland Six.

D. M. ERSKINE.  
Ambia, Ind.

The Halladay car is equipped with a rear axle made by The A. I. Smith Company, Milwaukee, Wis.

### Another Case of "Too Much Heat"

Editor THE AUTOMOBILE:

[2,744]—I have been having trouble with the engine on my Maxwell 30 and will ap-

preciate it very much if you can enlighten me on the subject.

A few weeks ago I noticed that it heated up very easily and finally stopped running. On examination I found that the condenser (the car is fitted with a Splitdorf magneto and coil) had played out. I returned the condenser to the factory and had it repaired, but on placing it on the engine found that it heated up as badly as it did before. I then thought there was carbon in the cylinders and used a decarbonizer in them very freely, but it still heats up.

Arvonnia, Va. E. E. ROBERTS.

If you are sure that the lubrication is sufficient and that the ignition system is now in proper order try reducing the supply of gasoline to the carbureter, the mixture perhaps being too rich.

### Belt Dressing Has Been Used in the Past

Editor THE AUTOMOBILE:

[2,745]—I am a subscriber to your magazine and read everything carefully. I there-

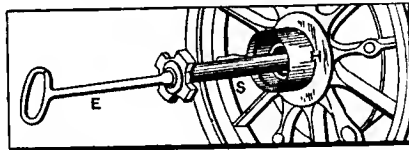

Fig. 3.—Showing how the jackshafts can be withdrawn from a full floating axle and the style of tool used for the purpose

fore take the liberty of asking you for a little space in your columns, as I have never found anything about a friction drive. I wish to ask you whether there is any powder or other substance which can be put on the fiber wheel to prevent it from slipping when there is a hard pull at the start. I enclose herewith cut of the fiber wheel. Could this be changed to a shaft drive without incurring a very high expense?

WM. WIEMAR.

Belleville, Ill.

It might be a good idea to drill a lot of holes around the periphery of the disc and insert cork in these holes for the purpose of increasing the friction coefficient sufficiently to accomplish the desired end. It would be a simple matter to drill a series of 1/2-inch holes around the periphery of the wheel, centering these holes from 3/8 to 7/8 of an inch apart, and the cork inserts might be 5/8 inch in diameter, so that when they are compressed into the 1/2-inch holes they will remain there, excepting that the surfaces will protrude out slightly, serving as the friction members. Still another plan that might be worth trying, since it is simple and inexpensive, is to take a piece of high-grade linoleum, reducing its thickness to perhaps 1/16 of an inch or slightly more, and fasten it to the periphery of the

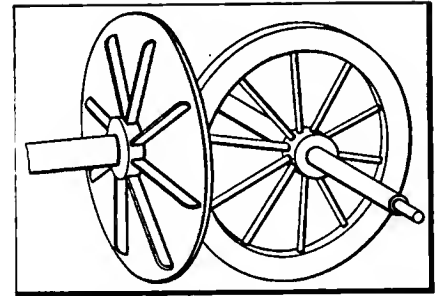

Fig. 4.—Method of transmitting power from the flat disc to the fiber-covered friction wheel

wheel, using it as the friction member. It might be a little difficult to get this material to adhere to the wheel tenaciously for a long time, but it should be made to serve the purpose, unless you wish to go to the greater pains of using the cork inserts. Perhaps the National Brake & Clutch Company, of Boston, Mass., which concern deals in cork inserts, might be willing to suggest a method of using them under your conditions that will take you out of trouble. It would be a serious matter to undertake to rebuild the car with the idea uppermost of turning it into a shaft drive.

### Brake Adjustments Made Easy

Editor THE AUTOMOBILE:

[2,746]—I noticed in recent issue of THE AUTOMOBILE on page 1121 that you described a good method of operating the brakes in the rear wheels. I have had this fitted to my car and it works very well and is a good equalizer. I live in a hilly district and have occasion to tighten the brakes frequently and will trespass on your space. Could you give me a sketch of a method of adjusting the brakes other than that shown in the illustration referred to? Something that can be done by hand if possible by lifting the floor boards.

Reading, Pa.

BERKSITE.

No doubt you will find what you require if you will refer to Fig 5. In this illustration it will be seen that the brake lever arm is in the center of the chassis and the thumb nut on the end of the threaded rod is all that needs turning. The spring interposed between the arm and the locking nut holds the rod in place, prevents rattling and keeps a continual tension on the thumb nut, which would otherwise have to be fitted with a locking device.

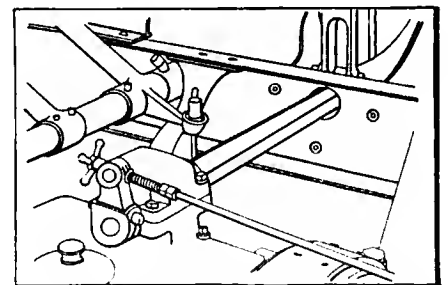

Fig. 5.—Method of making a brake adjustment that can be easily tightened

# Meeting Recurring Troubles

## Presenting a Series of the Most Probable Cases

A series of correlated short stories, accompanied by diagrams and characteristic illustrations, including the nature of the troubles that are most likely to happen to automobiles, discussing their causes and effects, all for the purpose of arriving at a remedy. It is the aim, for the most part, to show how these troubles may be permanently remedied, and as a secondary enterprise it is indicated how the automobilist can make a temporary repair, thereby enabling him to defer the making of a permanent repair until a convenient time arrives.

**LUBRICATION OF THE HUPMOBILE MOTORS**—The oil supply reservoir of the Hupmobile motor is located near the top of the right-hand side of the cylinders, the upper part of the tank and the cylinders being on the same level. The tank is filled through a filler hole on the top which is covered by a screw cap. There is a gauze screen in the filler opening so as to remove all foreign matter and prevent it from entering the tank.

In the tank box there are two needle valves which, when closed, prevent the oil from flowing from the reservoir. A spiral spring on each of these valves holds them down on their seats. The seats are beveled perpendicularly to the level on the valve stem and this, acting in conjunction with the pressure exerted by the spring, gives an oil-tight fit. The valves are lifted by an arrangement of rods and levers from the same rocker arm as the throttle. A projection on the throttle rod performs the office of a cam and is arranged so that the farther the throttle is opened, the higher the oil valves are lifted.

When the needle valves are opened the oil flows by gravity through the two oil leads which are located in the bottom of the oil tank. The oil leads take the oil to the crankcase which is divided into two parts by the central main bearing.

The oil fills the bottom of the crankcase on each side of the division in the center to such a height that the bottoms of the connecting rods will dip deep enough into the oil to form an adequate splash. So that the oil can not accumulate above the designed level, there is a stand pipe provided in each division of the crankcase, located between the front and rear pair of connecting rods respectively. Since the stand pipes are left open the oil, after it has reached the level of the top

of them, will drain through. A drain cock, which, when running should be left closed, is situated under each stand pipe.

When the connecting rods dip into the oil, even if the car is running slowly, a heavy oil vapor will be generated which will pervade the entire crankcase and lubricate the cylinder walls, connecting rod bearings, cams, cam shaft bearings and the main bearings. After passing through the rear main bearing the oil flows into the gearcase and clutch housing and lubricates the moving parts therein. On the gearcase and clutch housing at the rear of the motor, there is a level cock and a drain plug in the bottom. The crankcase is also provided with drain plugs besides the stand pipe

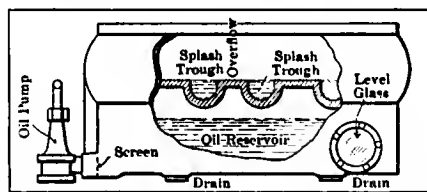

Fig. 2—Illustrating the oil reservoir and splash troughs on the Haynes car

cocks already spoken of. There is a level glass in the reservoir-hox at the rear end. Another point to note is that there is about one-sixteenth of an inch clearance on either side of the wrist pin to permit a free access of oil to this bearing.

The differentials, universal joints and rear axle housings are packed in grease. The rear axles are equipped with babbit bearings, to prevent the oil from leaking into the brakes.

**HAYNES LUBRICATING SCHEME IN DETAIL**—The oil reservoir of the Haynes Model 20 car is located in the lower part of the crankcase. Its capacity is about one and one-half gallons. The oil is put into the tank through the breather pipe which contains a screen. The cover to the breather pipe is lifted off, thereby exposing the filler opening.

The oil is taken from the reservoir by an external gear pump which is driven off the camshaft by means of gearing. The pump is located at the rear end of the base on the right-hand side. There is a sight-feed located on the dash.

After leaving the sight-feed the oil flows down into the crankcase by means of a pipe which subdivides into two leads in the base of the motor. These two leads on the opposite sides of the motor are on the same level with one another and also on a level with a series of oil troughs which are placed inside the crankcase.

The connecting rods heat the oil in the troughs into a spray which lubricates the cylinder walls, connecting rod bearings, main bearings and the camshaft. After lubricating these bearings the oil will drain back to the troughs which are constantly being supplied with more oil by the two ducts on either side of the oil trough, one coming from each main lead from the pump. To take care of the overflow there is a drain hole between each pair of splash troughs. There are four of these splash troughs and two drains. As the oil overflows constantly there is always a stream of oil passing through the drains back into the reservoir, replenishing the supply here.

So as to allow the pump to get the last drop of oil that it is possible to give it the casting has been dropped a little at the rear end near the pump suction pipe, thus forming an oil pocket. There is a strainer placed in the pump suction lead which will ensure a clean supply of oil to the bearings. It is very important that this strainer should be kept clean and it is therefore advisable to remove and clean it occasionally.

The amount of oil in the tank may be readily determined by means of a four-inch gauge glass which is located on the front end of the crankcase on the right-hand side. A test cock at the correct level forms a sort of auxiliary gauge. The crankcase is also equipped with drain plugs.

CUNNINGHAM CARS USE SPLASH AND FORCE-FEED —The Cunningham Model H car is lubricated by

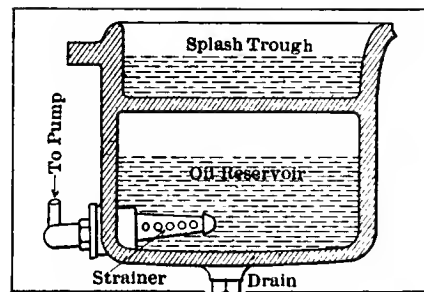

Fig. 3—Cunningham model H crankcase showing lead to pump

both the force feed and splash systems. The oil is carried in the lower part of the base or oil pan casting of the engine. This casting is made with a type of double bottom. The upper bottom carries a set of oil troughs for the splash system, while in the lower bottom the reserve supply of oil is carried.

The shape of this oil tank is merely a plain basin although it is somewhat deeper near the rear end.

The oil is picked up out of this tank by means of a gear pump. The pump is driven from the camshaft by means of spiral gears. The suction pipe leads down into the reservoir and at the end is supplied with a strainer. The oil is drawn up to the pump, from which it is driven both through the sight feed and the main oil lead. The amount passing through the sight feed bears a definite ratio to the total amount which circulates through the system; as the sight feed lead forms a sort of by-pass to the main lead. The proportion passing to the sight feed may be altered by means of a regulating valve on the sight feed lead at the rear of the motor on the left-hand side.

The rest of the oil from the pump goes to the main lead which consists of a bore drilled longitudinally through the entire length of the aluminum crankcase casting. At each main bearing a lead is drilled through the aluminum to the main lead, which is on one side of the casting, connecting this and the main bearing web. Another lead is then drilled down through the main bearing web into the casing, thus lubricating the main bearing. The oil then overflows out of both sides of the main bearing casing into the splash troughs.

The scoops on the bottom of each connecting rod pick the oil and churn it into a flying spray, which amply lubricates the cylinder walls and connecting rod bearings as well as the camshaft bearings. The wrist pin is hollow and open at both sides. When the oil in the splash troughs overflows it drains back by means of overflow holes into the oil reservoir, from where it is again picked up and passed through the system.

There is a brass level gauge on the left-hand side of the crankcase showing the amount of oil present in the reservoir; the total capacity of the reservoir being about three gallons. The filler hole is screened.

Other bearings on the car are equipped with grease cups while the transmission and differentials are packed in oil and grease.

**LUBRICATING POPE-HARTFORD ENGINES**—The lower half of the crankcase of the Pope-Hartford engine is cast so as to form an oil reservoir in the bottom. Above this reservoir there is a sort of tray carrying a series of troughs, one for each cylinder, which carry the oil for the splash system. The walls of these troughs are at such a height that if the oil is on a level with the top of the wall, the bottom of the connecting rod will dip deep enough to form an efficient splash. If the oil should overflow the walls it will pass into the bottom of the base casting.

The oil is drawn from the reservoir up into a mechanical oiler located on the side of the engine base. Before entering the mechanical force feed box the oil passes through a sight feed. From the box there is a series of tubes running to the various cylinders, each tube being provided with a small plunger pump. These pumps take the oil out of the box, through a sight-feed and, from there, to the walls of each cylinder. The oil, after having lubricated the cylinder walls, will drain back to the crankcase.

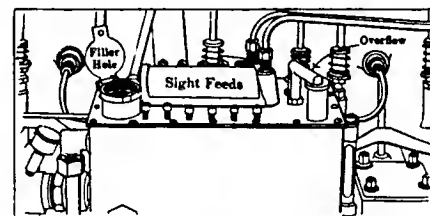

Fig. 4—Mechanical oiler of the Pope-Hartford car

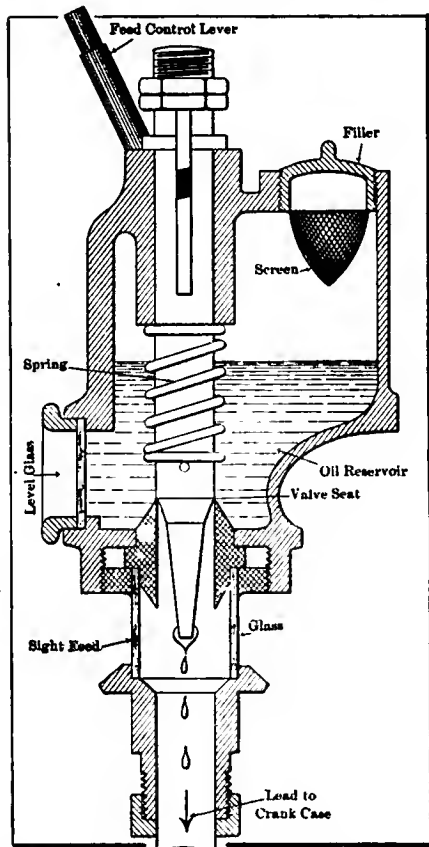

Fig. 1—Section showing the drop feed and oil tank on the Hupmobile



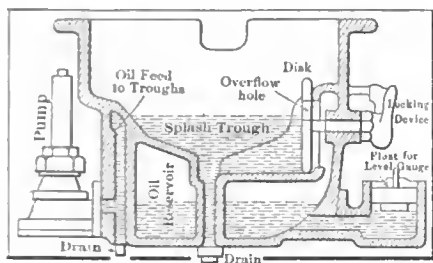

Fig. 5—Sectional view of the Pullman crankcase showing the oil channels and drains

The cylinder walls are also lubricated by the splash of the connecting rods into the oil troughs. The mechanical oiler is driven by a shaft operated from the crankshaft. The shaft passes directly through the oiler driving not only that but also the water pump and magneto. Each lead in the mechanical oiler is equipped with a sight-feed located on the top of the oiler box so that it is easy to detect the location of any trouble in the system. A gauge glass is fitted on the dash showing the level of the oil in the force-feed box. When it is required to ascertain the amount of oil in the reservoir it can be done by means of two test cocks located on the side of the crankcase, the upper test cock being at the maximum permissible level, while the lower is at the minimum.

The oil is pumped up by means of the suction pipe from the crankcase much faster than it is used in the leads to the cylinder walls; hence there is always an overflow passing through an overflow pipe in the force feed box. This overflow pipe leads into the camshaft housing thus lubricating the cams, cam followers and the bearings connected with the camshaft. The excess oil drains through the overflow pipes and filter screens back into the reservoir. There is also a lead from the mechanical oiler to the gear case in the front of the engine. Otherwise these gears may be packed in grease. The other gears are oiled by splash from the crankcase.

The transmission and differentials run in oil and in their housings are located test cocks showing the level of the oil. Compression grease cups are located on the other bearings such as the clutch, universal joints, axle bearings, steering gear bearings and the oscillating spring bearings.

**PULLMAN CARS OILING SYSTEM**—Pullman cars are lubricated by the splash system. The crankcase is molded so as to have a double bottom. The inner bottom carries a set of splash troughs, one under each cylinder, which form the basis of the system of lubrication. Below this inner bottom is the oil reservoir, which takes in the whole lower part of the crankcase.

The reservoir is filled through an opening in the front left-hand crankcase supporting arm. The amount of oil present in the reservoir is determined by means of a level gauge glass located on the left-hand side of the motor between the two middle cylinders.

The rotary oil pump is located at the rear end of the crankcase on the left-hand side. It is driven off the camshaft by means of gears and a vertical shaft. This pump takes the oil from the rear end of the crankcase reservoir and sends it up into the splash troughs.

The connecting rods splash violently into the oil contained in these splash troughs at each revolution of the motor and heat the oil into a heavy vapor or mist which pervades the whole crankcase and amply lubricates the hearings contained therein.

The oil is continually being supplied to the motor much faster than it is being used and the overflow is taken care of by means of an overflow hole in a disk which is located in each splash chamber. This disk is able to rotate about its axis and in this manner raises or lowers the overflow hole which of course, is not concentric with the disk. To keep the overflow level to its correct adjustment there is a locking device on the outside of the crankcase.

To prevent the oil from leaking past the end of the crankcase a centrifugal oil ring is hung on the end of the shaft. The oil is caught up by this ring as it drains toward the outside of

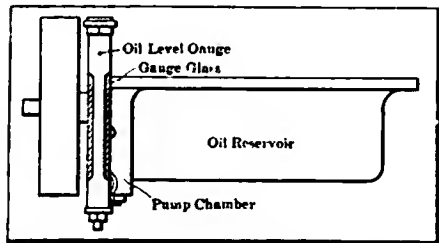

Fig. 6—The oil reservoir of the Mercer "30 M" showing level gauge and pump chamber

the crankcase and is thrown by centrifugal force off the ring to the sloping bottom of the crankcase down which it drains to the reservoir.

The oil may be drained from the splash troughs by means of drain pipes which take the oil from the bottom of the troughs and allow it to flow from the bottom of the crankcase. The reservoir itself is also equipped with drain plugs, both front and rear, so that it may be completely flushed out and cleaned.

There is also a drain under the passage through which the oil flows on its way from the pump to the splash troughs.

The other hearings all over the car are taken care of in the usual manner; and the differentials and transmission are packed in oil and grease.

**COMBINATION OILING SCHEME ON MERCER "30"**—The Mercer "30 M." is lubricated by a combination of the splash and force-feed systems, the force-feed part of the combination forming the primary method of lubrication.

About two gallons of oil are carried in the lower part of the base casting. This casting is divided so that while the lower part forms the oil carrying tank there is a moulded sort of tray in the upper part so that there is a series of oil troughs in it.

Openings in the tray permit the oil which overflows from the troughs to get back into the tank below. At the rear or flywheel end of the base there is a level gauge showing the amount of oil in the tank. This gauge is of the float type, a dial plate being placed horizontally on the end of the float tube. The float tube is carried high

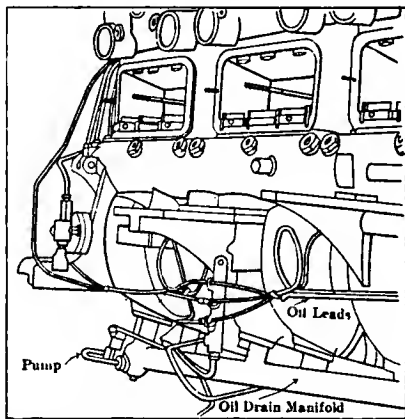

Fig. 7—Illustrating the Winton oil drainage system and the supply leads from the pump to the various bearings

enough so as to be visible when raising the right-hand part of the engine hood.

The oil tank is filled through the breather pipe which extends up very high from the top of the forward end of the crankcase on the right-hand side.

The force-feed system is operated by a Pedersen pump of the rotary type, located within the crankcase casting, which has a small pump chamber located on the rear right-hand side.

The stream of oil taken from the reservoir is sent through an upward lead, a sight feed on the dash, and then, to the main bearings of the crankshaft. The oil lubricates the bearings copiously and then runs out of both sides of the hearing casings where it is caught up by pockets of a cup-shaped form, which have an oil hole in the bottom. This oil hole registers with an opening in the crank, which is hollow, as is also the crank pin. The revolving cranks send the oil to the crank pins by centrifugal force.

A spray of oil is being constantly thrown off the connecting rods which serves to keep the crankcase filled with a mist of oil.

The splash troughs should be filled before starting on a trip and, with the oil draining constantly into them from the force-feed system they will be always overflowing no matter at what level the car is running.

The connecting rods dip into the troughs and splash the oil up into the cylinder, lubricating the walls, as well as the cams, cam followers, cam shaft bearings, timing gears and wrist pin.

The other hearings on the car are equipped with grease cups and oiling holes according to their positions. The transmission is placed in an oil tight case and runs in an oil bath.

**DETAILS OF WINTON OILING SYSTEM**—The Winton engine is oiled by both the splash and force-feed systems. The oil supply reservoir on the left-hand side of the motor is box-like in form and holds about eleven quarts. The oil reservoir is filled by means of a square opening in the top of the tank, the cover of which is removed by turning a round handle which projects from the top of the box. A gauze strainer is located just within the cover.

The oil is kept in circulation by twin pumps driven by the same eccentric off the crankshaft.

The oil is pumped by one of these pumps to the top of the crankcase, from where it is led through direct leads to each main bearing. The crankshaft is drilled to provide an oil channel up into the crankpin, which is also drilled so as to provide an outlet for the oil into the connecting rod bearing, which is lubricated in this manner sufficiently to allow of an overflow of oil. This oil is thrown up into the cylinder and drains down into the splash troughs, which are inlaid directly in the bottom casting of the motor and are of sufficient depth to provide an oil well into which the connecting rod is allowed to dip, beating the oil into a spray. When the oil has reached the proper level in the splash troughs it is allowed to flow back to the rear of the engine base through a drain pipe. Here the oil is picked up by the twin plunger pump and delivered to the tank, where it flows through a vertical tube which stands perpendicularly in the tank and which is perforated near its top extremity. An umbrella-shaped baffle is placed over these perforations so that in case the cover is removed while the engine is in motion the oil will not spurt out of the tank.

The amount of oil supplied is regulated with a by-pass equipped with a throttle cock. When the latter is closed the entire oil flow passes through the system. When the cock is opened, however, there is a flow through the by-pass which takes the oil from the bottom through the pump into the top of the tank. If the cock is fully opened there will still be a small flow through the lubricating system, this being the minimum flow obtainable through the system.

**SPLASH SYSTEM ON THE MAXWELL I**—The Maxwell Model I is lubricated by the oil spray created by the splash of the connecting rods into the pools of oil which are held by the series of troughs placed below the respective cylinders. The oil supply is held in the bottom of the crankcase in these splash troughs and also in the supply tank, and is kept in a state of continual circulation. This circulation is kept up by means of a gear driven pump located on the left-hand side of the motor and operated by means of the cam shaft.

The course of the oil as it passes through the oiling system may be traced by following the pipe leads starting from the tank. The oil starts from the tank which is placed at a considerable height above the pump and therefore has a head sufficient to give the oil a ready flow. The lead from the tank to the pump is for the most part straight and leads directly into the suction port. From here the oil is forced up to the sight feed on the dash. After passing through the sight feed the oil will flow down into the crankcase to replenish the supply in the splash troughs and maintain it at the proper level. After attaining this level there will be a flow into the stand pipe placed at the proper height to catch the oil and lead it back again to the pump, from where it is passed up to the tank from which it started and is thoroughly strained before again passing through the system.

All the moving parts within the motor itself are lubricated by the splash.

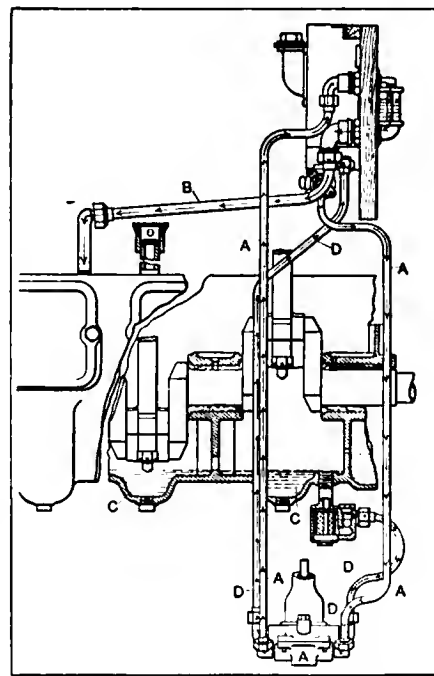

Fig. 8—The oiling system of the Maxwell I. A—Lead from tank to pump and sight feed. B—Sight feed to crankcase. C—Splash troughs. D—Lead from splash troughs to pump and back to tank



# Making Maps for Air Travel

## To Enable Aviators to Find Their Way Day or Night

The French Government, which has made the aeroplane an adjunct of the army, has just finished plotting the first of its charts designed specially for the guidance of aviators, and is actively at work on similar charts covering four thousand square miles of territory. A reproduction of the original map and an illustration showing the manner of its installation on the air machine are here given, intended to help to a proper understanding of the text.

AERIAL navigation has reached a stage of development in Europe, and especially in France, of which the average American, for all his intense and intelligent interest in this novel and fascinating form of locomotion, has little conception. On this side of the Atlantic opportunities of observing at first hand the capabilities of the aeroplane are still limited to infrequent and widely scattered exhibition flights and the small-scale experiments of the War Department. In Europe the aeroplane, as evidenced by the report a few days ago of the inauguration of taximeter-aeroplane service out of Lucerne, has become

a staple of transportation. Aeroplane hangars are as common as automobile garages were in the United States a dozen years ago, hydrogen gas depots for the service of dirigible balloons are to be found in every considerable town, and aerial flights, except the very few especially remarkable for extreme length or extreme daring, such as the crossing of the English Channel, the Pyrenees or the Alps, arouse only the languid interest of the every-day spectacle.

In France the manufacture of aeroplanes has become an industry of large proportions. A year ago Blériot had already sold over two hundred and fifty machines, and Farman, Sommer, Antoinette and Voisin had booked orders for from twenty to fifty machines each. In the interval other manufacturers have entered the field, and the demand for aeroplanes has grown at a tremendous rate. All the manufacturers issue handsomely illustrated catalogues of standard sizes and types of stock machines. Each manufacturer has from one to three factories, and each his *école* for the instruction of intending purchasers and of professional aeronauts. For about 1000 francs one can learn to fly and obtain a pilot's license. A year ago these schools of flight had graduated over four hundred pupils. To-day their monthly output numbers scores.

The actual piloting of aircraft over the short distances and at low altitudes attempted in the early days of aerial navigation was a matter of no difficulty. The pilot was always in sight of familiar landmarks and knew, in a general way at least, the character of every foot of the ground over which he flew. But as soon as cross-country flights became common pilots on "the high seas of the air," to quote a French army pilot, discovered that charts were an absolute necessity, and they were not long in making the further discovery that their requirements were very imperfectly met by the topographic maps of the ordinary character available to them. Hence there arose an increasingly insistent demand for charts especially designed to meet the needs of aerial navigators. The first step toward the

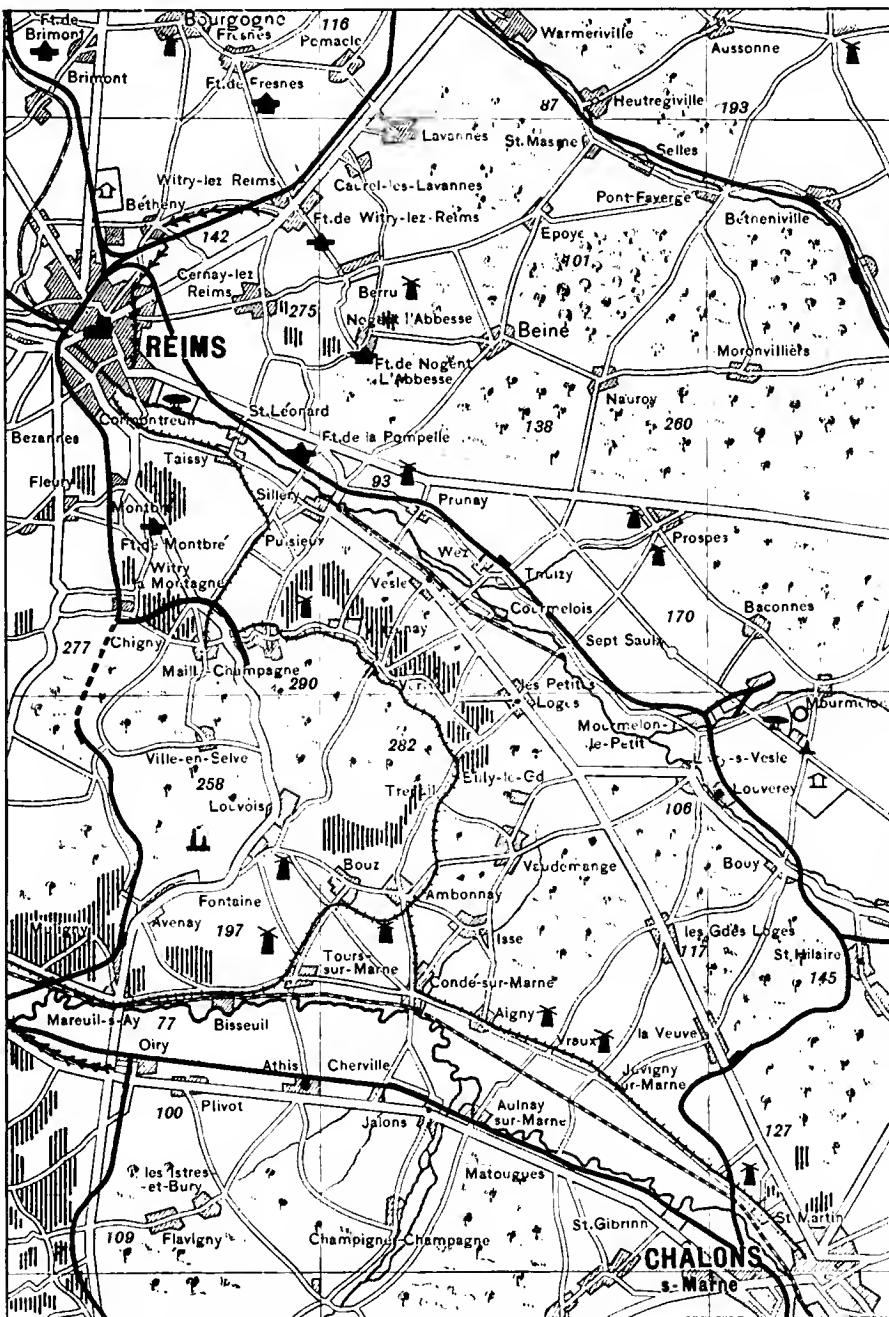

A part of the Châlons sheet, showing the twenty-five miles between Châlons and Reims

complete charting of the country for aerial service has just been taken in the publication, by the Geographic Service of the French Army, of an aeronautic chart covering an area of nearly 4,000 square miles.

As a matter of fact, French air pilots had no choice but to await with what patience they could the initiative of the War Department. The Geographic Service of the Army is the only organization in the country with means at its disposal for rapid and efficient execution of work of this character. In spite of the urging of the sporting fraternity, and even of aeronautic experts within the Army, the War Department showed no interest in the matter until about two years ago and no inclination to carry out the project of recharting the country until after the grand Army maneuvers in Picardy in 1910. Aircraft were given a thorough trial in these maneuvers in military operations on a grand scale and conclusively demonstrated the immense possibilities of the aeroplane and dirigible in warfare. The War Department suddenly awoke to the value of special charts for aerial service, and, after a thorough inquiry into the requirements of air pilots, instructed the Geographic Service to prepare and publish, as an experimental sheet, an aeronautic chart of the district about Châlons.

The ideal set before the designers of the chart was to produce a map which should give the air pilot all the data necessary to enable him to set and hold a course at any time and under any atmospheric conditions, to avoid dangerous landings and to locate himself readily by the landmark indications on the chart at any point of the region covered by the sheet. The problem of largest importance was the determination of the proper scale and size of the printed sheet. It had to be small enough for convenient handling and at the same time cover a considerable area, so that when sheets are available for the whole country the pilot on long flights will not be unduly burdened with paper. Most important of all, the many data to be accommodated on the chart had to be disposed in such a manner as to be clear and legible at a glance.

The chart indications essential to aerial navigation are much more numerous than those of the ordinary topographic map. The aeronautic chart must show all roads, distinguishing the main highways from those of secondary importance, for the air pilot in flying over inhabited places or road intersections must be able to recognize the route leading to his projected destination. Double-track railways must be distinguished from single-track lines, since the latter are invisible from altitudes above 1,400 feet. Water surfaces, being visible from great distances and any altitude, are most important as landmarks, and all streams, lakes, and ponds must be clearly marked. Woods and forests also are extremely good landmarks, and the indication of clearings and of main forest roads is of importance. The charting of towns and villages must show their actual shape, the courses of all intersecting roads, and especially the exact location of the principal church steeples. In country districts, large buildings, windmills, isolated trees and cemeteries must be shown when they are salient features of the landscape; the smoke

stacks of factories also are in many cases useful indications of direction. Fundamentally, of course, the aeronautic chart must be a topographic map and must show clearly the configuration of the ground, the valleys and gullies, the flat and sloping surfaces, isolated mounds and high bluffs. Altitudes must be given for every considerable elevation, not only to indicate their value as landmarks, but principally to show the pilot how high to fly. The mean declination of the compass must be indicated, to enable the pilot to fly during darkness and to regain his course when driven out of it by adverse conditions. Finally, the chart must show the location of all aviation parks, military parade grounds, hangars for aeroplanes and dirigibles and hydrogen gas depots and especially places where an attempt to land would be attended with great danger on account of the presence of vineyards, orchards, gardens, hop fields, ditches, hedges, quarries or electrical transmission lines.

In the Châlons sheet just published by the Geographic Service these diverse elements have been combined in a highly successful manner. In a reasonable space and without undue crowding they

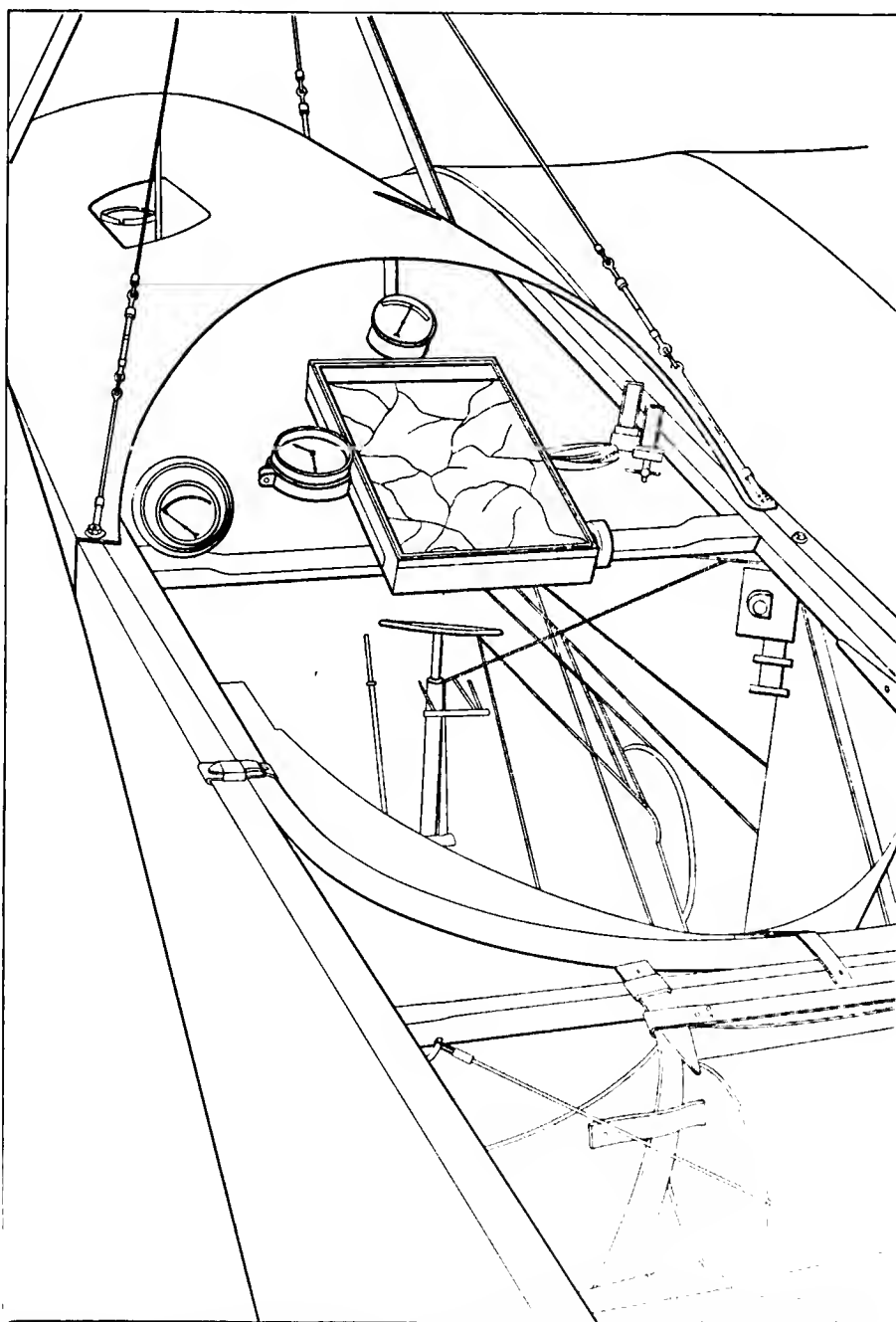

The quarterdeck of a Blériot monoplane. In the center the chart holder; on the right, the compass; above, the barometer; on the left, the clock and the revolutions indicator

have produced a chart which is really an adequate picture of the district covered by the sheet, legible at a glance and readily understood by a person having no previous experience with topographic maps. The scale chosen was that of the ordinary military maps of the French Army, 1 to 200,000, about three miles to one inch. The sheet measures 16 by 25 inches and covers an area of about 50 by 80 miles.

The chart is printed in six colors. The basic tint is buff, toned to represent the topography of the ground. Against this background the white of the roads and the blue of the water surfaces stand out clearly. Woods are indicated in tones of green, and towns, villages and dangerous landings in red. Black is used for railways, railway stations and figures of altitude. The actual profiles of important churches, steeples and towers are silhouetted in black. Conventional signs shown in the accompanying key, also printed in black, are used for smoke stacks, large buildings, windmills, isolated trees and other landmarks. Aviation parks and military parade grounds are printed in white over the buff and bear in red the conventional signs used for dirigible and aeroplane hangars and gas depots. The magnetic declination is printed in degrees on the margin.

The experience of the aeronautic experts of the military establishment at Châlons has shown this experimental sheet to be admirably suited to the purpose for which it was designed. Encouraged by its success, the War Department has ordered the charting of the quadrilateral Paris-Amiens-Givet-Bar le Duc, an area of over 9,000 square miles, which is to be the scene of the grand maneuvers during the present Summer. The indications for the use of air pilots incorporated in the Châlons sheet have been found useful in military operations on the ground.

## Differential for Aerial Propellers

*Granting that landing is that phase of aeroplaning which has caused the destruction of many a machine, the device here described is expected to prevent many accidents of this kind. The original appeared in Der Motorwagen.*

IN landing after most aerial flights gliding is resorted to, the engine having been shut off for this purpose. Such a landing is always dangerous, at least in a certain measure, both for the machine and the operator, since preparations for landing are made at an altitude frequently so great that such

obstructions as fences, inequalities of the ground, etc., are not always noticed. When the flying machine has come so close to the ground that these objects can be recognized distinctly the impossibility of a successful landing may be seen, in many cases, too late to restart the engine and rise to a greater altitude. This takes time, as two operations are necessary to attain the end, viz., the restarting of the motor and the adjustment of the elevating rudder. Furthermore, fractions of seconds are decisive at such times.

It happens even to skilled operators that the wheels or the chassis of the aeroplane come to grief in landing, and there is nothing surprising about such an occurrence, considering the high velocity with which the machines strike the ground. Braking the front wheels would in most cases result in overturning the machine owing to the inertia of the rear portions, while braking the rear wheels would probably be without any effect because of the small weight of the tail end of most machines. However, braking is desirable in aeroplaning for other reasons also, principal among which is the fact that there is seldom an abundance of landing ground.

But, since a great velocity is essential in making a gliding descent, the brake effect should be a sudden and strong one at the very moment when the front wheels touch the ground, or, better yet, when they are still about two or three feet above it.

To effect braking and also to make possible an easy upward start after gliding for some time, the German constructor, M. Bucherer, of Cologne, has built a differential brake for aeroplanes, the essential feature of which lies in the possibility of slowing down and eventually reversing the propeller at the right instant to enable the aviator to make a safe landing.

The inertia of the flyer naturally excludes the possibility of reversing the motion of the machine as a whole, the effect of which would be a disastrous one, and the only result of reversing the propeller is a very considerable reduction of its speed just before it is expected to land. If, however, a handicap should be espied at this instant the motor power could be utilized again to rise higher in the air.

In the illustration is seen the Bucherer aeroplane engine, which is of the rotary type, with air-cooled cylinders of 90 by 182 millimeters. The propeller is not mounted on the crankshaft, in accord with the general practice of the day, but a differential gearset connects crank and propeller shafts. The crankshaft carries a disc, on which two pivots are placed diametrically. These, in turn, carry the revolvable internal brake jaws.

The internal and external brake jaws, which are located at the inner and outer surfaces of the brake housing respectively, are actuated alternately. The housing contains, in its front portion, a differential gearset, the small pinions of which are rotatably located on the two pivots of the axle cross. One of the two large differential wheels is a unit with the crankshaft and the other with the propeller shaft. The external brake is located at a point not shown in the illustration.

The operation of the differential is as follows:

1. If the external brake is loose the crankshaft turns from the left to the right. The internal brake is held in such a position that its jaws make the housing rotate by friction. The small pinions act as a clutch between the large wheels, and the propeller shaft is rotated in the same sense as the crankshaft.

2. If both the external and internal brakes are loose the small pinions are driven by the one big differential wheel and work on the other wheel of the propeller shaft.

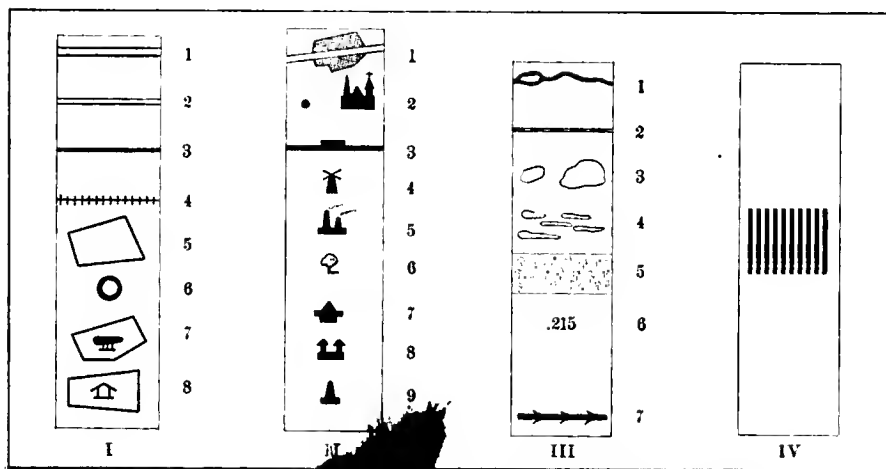

THE CONVENTIONAL INDICATIONS FOR USE OF AIR PILOTS

1, Main highways; 2, other roads; 3, narrow-gauge railways; 4, single- or double-track; 5, aviation hangars; 6, hydrogen-gas depots; 7, dirigible hangars; 8, aviation parks; 9, towers; 10, churches; 11, railway stations; 12, windmills; 13, smoke castles; 14, towers; 15, windmills; 16, altitudes; 17, electric pylons; 18, orchards, gardens, hop yards, quarries, ditches

which latter does not now rotate. The brake housing rotates with the small pinions.

3. If the internal brake is loose and the external brake is fast in position, holding the brake housing in place so that it cannot revolve, the state of affairs is as follows: The crankshaft rotates as before, from left to right. The small pinions which are set on pivots in the now resting brake housing cannot revolve around the crankshaft and thus impart motion to the propeller shaft, which is made to rotate in the opposite direction to the crankshaft, from right to left.

If this machinery is utilized for landing it is possible to reverse the propeller instantly by braking the housing by means of the contracting-band brake without stalling the motor. At the same time the free-running number of revolutions of the engine falls to normal, and the motor then drives the propeller with full force in the direction opposite to that in which it was rotated before thus holding the aeroplane back.

The increase of weight and the addition of machinery to the aeroplane ought to be compensated for by the various great advantages of the installation of the differential set on the aeroplane.

## As to Motion Study

*The principle of intensive cultivation, as it is understood in an agricultural sense, must be applied to the production of automobiles, if the manufacturer hopes to make the most of his facilities.*

INTENSIVE cultivation is the idea which dominates the activities of a burglar when he is prying open a vault, just as much as it is the idea that stands behind efficacious work in an agricultural sense. It is this same intensive cultivation that permits one maker of automobiles to turn out a large number of cars per annum under a given set of conditions and it is

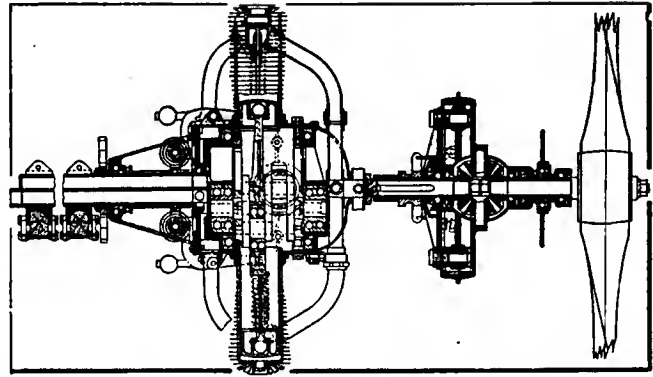

Section of the Bucherer rotary aeroplane engine in which a differential is interposed between the engine crankshaft and the propeller shaft

the absence of this condition that keeps another maker, although he may be endowed with the same facilities, from getting his quota of results. As a preliminary to intensive cultivation, motion studies will have to be indulged in, and the impression is harbored that too many builders of automobiles have substituted the brutality of the "accelerator" for the intelligent wiles of the master in motion study; but the time is not so far away when intelligence will have to sway the issue, even at the expense of being introduced in the person of the receiver. There is a superstition which has its foundation in the idea that co-operation is supplanting competition, but when the awakening comes the victims of lack of foresight will find to their sorrow that the master of motion study is the leader in the competitive department, and that his cleverness is two-fold, due to the fact that he not only points the way to more and better work per dollar of overhead, but he does it so silently that the neighboring maker who should be in a position to compete for success is fettered to his own stupidity.

# Calendar of Coming Events

## Handy List of Future Competitive Fixtures

### Race Meets, Runs, Hill-Climbs, Etc.

July 5-22.....	Winnipeg, Man., Fourth Canadian Competition for Agricultural Motors.
July 15.....	Philadelphia, Track Races, Belmont Park, Norristown Auto Club.
July 14.....	Philadelphia, Commercial Reliability Run, Quaker City Motor Club.
July 15.....	Guttenberg, N. J., Track Races.
July 15-17.....	St. Louis, Mo., Reliability Run, Missouri Automobile Assn.
July 17-19.....	Cleveland, O., Three-Day Reliability Run of the Cleveland News.
July 17-22.....	Milwaukee Reliability Run, Wisconsin State Automobile Association.
July 21-22.....	Brighton Beach, N. Y., Twenty-four-Hour Race.
July 20-28.....	Minneapolis Reliability Run, Minnesota State Automobile Association.
Aug. 1.....	Chicago, Ill., Commercial Reliability Run, Chicago Evening American.
Aug. 3-5.....	Galveston, Tex., Beach Races, Galveston Automobile Club.
Aug. 12.....	Philadelphia, Reliability Run, Quaker City Motor Club.
Aug. 12.....	Worcester, Mass., Hill Climb, Worcester Automobile Club.
Aug. 17.....	St. Louis, Mo., Reliability Run, Missouri Automobile Assn.
Aug. 25-26.....	Elgin, Ill., Stock Chassis Road Race, Chicago Motor Club.
Sept. 1.....	Chicago, Ill., Commercial Reliability Run, Chicago Motor Club.
Sept. 1.....	Oklahoma, Reliability Run, Daily Oklahoman.
Sept. 2-4.....	Brighton Beach, N. Y., Track Races.
Sept. 2-4.....	Indianapolis Speedway, Track Races.
Sept. 4.....	Denver, Col., Track Races, Denver Motor Club.
Sept. 7-8.....	Philadelphia, Track Races, Philadelphia Auto Trade Association.
Sept. 7-9.....	Hamline, Minn., Track Races, Minnesota State Automobile Association.
Sept. 12-13.....	Grand Rapids, Mich., Track Races, Michigan State Auto Association.

Sept. 15.....	Knoxville, Tenn., Track Races, Appalachian Exposition.
Sept. 16.....	Syracuse, N. Y., Track Races, Automobile Club and Dealers.
Sept. ....	Denver, Col., Track Races, Denver Motor Club.
Oct. 3-7.....	Danbury, Conn., Track Races, Danbury Agricultural Society.
Oct. 7.....	Philadelphia, Fairmount Park Road Race, Quaker City Motor Club.
Oct. 9-13.....	Chicago, Ill., Thousand-Mile Reliability Run, Chicago Motor Club.
Oct. 16-18.....	Harrisburg, Pa., Reliability Run, Motor Club of Harrisburg.
Oct. ....	Atlanta, Ga., Track Races, Atlanta Automobile Assn.
Nov. 1.....	Waco, Tex., Track Races, Waco Auto Club.
Nov. 2-4.....	Philadelphia, Reliability Run, Quaker City Motor Club.
Nov. 7-10.....	Los Angeles-Phoenix Road Race, Maricopa Auto Club.
Nov. 9-11.....	San Antonio, Tex., Track Races, San Antonio Auto Club.
Nov. 10.....	Phoenix, Ariz., Track Races, Maricopa Automobile Club.
Nov. 28-30.....	Savannah, Ga., Vanderbilt and Grand Prix Races, Savannah Automobile Club.
Nov. 30.....	Los Angeles, Cal., Track Races, Motordrome.
Dec. 25-26.....	Los Angeles, Cal., Track Races, Motordrome.

### Foreign Fixtures

July 13-20.....	Ostend, Belgium, Speed Trials.
July 21-24.....	Boulogne-sur-Mer, Race Meet.
Aug. 6.....	Mont Ventoux, France, Hill Climb.
Sept. 2-11.....	Roubaix, France, Agricultural Motor Vehicle Show.
Sept. 9.....	Bologna, Italy, Grand Prix of Italy.
Sept. 10-20.....	Hungarian Small-Car Trials.
Sept. 16.....	Russian Touring Car Competition, St. Petersburg to Sebastopol.
Sept. 17.....	Semmering, Austria, Hill-Climb.
Sept. 17.....	Start of the Annual Trials Under Auspices of F. Auto, France.
Oct. 1.....	Gaillon, France, Hill-Climb.
Oct. 12-22.....	Berlin, International Automobile Exhibition.



Vol. XXV Thursday, July 13, 1911 No. 2

THE CLASS JOURNAL COMPANY

H. M. SWETLAND, President
A. B. SWETLAND, General Manager
231-241 West 39th Street, New York City

EDITORIAL DEPARTMENT

THOS. J. FAY, Managing Editor
GEORGE M. SCHELL, Associate Editor
JAMES R. DOOLITTLE HUGH P. MacCONNELL
HANS WEYSZ

ADVERTISING DEPARTMENT

W. I. RALPH, 1025 Old South Bldg., Boston LOUIS R. SMITH, New York
C. H. GURNETT, 910 South Michigan FRANK B. BARNETT, 309 Park
L. G. VOGEL, Avenue, Chicago Building, Cleveland
T. B. VAN ALSTYNE, New York and Phila. H. H. GILL, 427 Ford Building,
H. L. SPOHN, New York Detroit

Cable Address - - - - - Autoland, New York
Long Distance Telephone - - - - - 2048 Bryant, New York

SUBSCRIPTION RATES

United States and Mexico - - - - - One Year, \$9.00
Other Countries in Postal Union, including Canada - - - - - One Year, 5.00
To Subscribers—Do not send money by ordinary mail. Remit by Draft,
Post-Office or Express Money Order, or Register your letter.

FOREIGN SUBSCRIPTION AGENTS

ENGLAND:—W. H. Smith & Sons, Ltd., 188 Strand, London, W. C., and all book-
stalls and agencies in Great Britain; also in Paris at 248 Rue de Rivoli.
FRANCE:—L. Baudry de Saunier, offices of "Omnia," 20 Rue Duret, Avenue
de la Grande Armee, Paris.
GERMANY:—A. Seydel, Mohrenstrasse 9, Berlin.

Entered at New York, N. Y., as second-class matter.
The Automobile is a consolidation of The Automobile (monthly) and the Motor
Review (weekly), May, 1902, Dealer and Repairman (monthly), October, 1903,
and the Automobile Magazine (monthly), July, 1907.

INTEREST seems to be centered around the idea of
silence of performance of automobiles. In the last
few years the enthusiasm of salesmen was spent in the
process of telling customers how silently their products
performed. These salesmen were afflicted with a dis-
order that might have been called "hypnotic hearing."
Despite the terrific din that some of their products made
they could hear nothing in the shape of noise that seemed
to be worth recounting to their "prospectives." It is
almost uncanny that the silence of performance that they
thought they had entrapped in their mechanisms is a
reality to-day. The casting-out of the "noise devil" from
automobiles is the surest indication the world has ever
had of the fact that progress comes from promise and
that anything man desires he can get if he goes after it.

\* \* \*

EFFICIENCY is a much-abused word, meaning al-
most anything under the sun, and, at best, it is but
a relative term. The efficiency of an automobile must
ultimately be measured in terms of units of utility per
dollar of cost, but it will take a fair display of ingenuity
to describe a unit of utility. The best and the worst
automobile might succeed in carrying five passengers a
certain distance per day and continue to do the work for
a term of years with the cost ranging neck and neck, or
nearly so; but the worst automobile might ride its owner
into an early grave or an insane hospital, or into poverty,
whereas the best automobile should bring to its owner a
heaping measure of well-being. The difference between
the two may be measured in annoyance or the absence of

it, and it is more than likely that the annoying type of
automobile will beat a path to the tire man's store, the
place where they "compound" gasoline, and to the
garage repair-shop, whereas the car that holds within its
maw the fullest measure of utility will show a fondness
for the boulevard and a capability over the dirt road
leading to the house of ozone over the hills and far away.

\* \* \*

THERE is some evidence of a strained attempt to
create sleeve types of motors as shown by some of
the examples of these mechanisms as they appear in THE
AUTOMOBILE this week, and goes to show that all the
passengers in a "band-wagon" are not equally entitled to
ride. Getting into the "band-wagon" is a very popular
enterprise, but those who pay the piper will have to train
their ears to distinguish between the tune of the music
emitted by the fellow who occupies the front seat in com-
parison with the wail that characterizes the chap who
jumps on as the wagon goes by. It is going to be a
little difficult for the average purchaser of an automobile
to arrive at a safe and sane conclusion of the difference
between a good poppet valve type of motor and a bad job
in the field of newer promise. It might be worth while
to take a look at steam engineering for purposes of com-
parison, and a mental sojourn into the land of this old
and stable art will lead the observer to the conclusion
that the good examples of the various makes of steam
engines are as prevalent to-day as they were a decade
ago, but the users of steam engines seem to have the
good sense to put a 40,000 horsepower quadruple expan-
sion steam engine in an ocean greyhound, a 20,000 horse-
power compound engine in a locomotive, a "simple" en-
gine in an isolated plant, and a "safe" engine in an auto-
mobile. When the time comes to review the automobiles
of the next ten years it is fair to say that the well-de-
signed poppet valve type of motor will be represented by
many good examples of them, the sleeve type of motor
will have found its working level, the rotary valve will
be a member of the congress of desirable mechanisms,
and the piston valve will cast its shadow over a consid-
erable zone of activity.

\* \* \*

WHILE the struggle is going on to perfect motors,
making them more simple and reliable to the entire
elimination of noise, it will be the pleasure of most de-
signers to discover that the disconcerting sounds to which
automobilists take exception are largely in the chassis
outside of the motor. There is every evidence of the
ability of the worm drive co-operating with the silent
chain to cure these noises. With silence of performance
will come long life, and in the explanation of the reason
for this desired condition account must be taken of the
increased flexibility that is a natural attribute of a chain
drive. Any mechanism that will prevent the load from
coming on the members positively and quickly will save
these members from the shock of instant loading, and a
simple way to appreciate the good that will come from
softening the blow lies in the mere statement that if the
time of loading is increased to two seconds instead of
one, the shock will be halved. There is every reason to
believe that the designers of automobiles have turned
their backs upon the "stable platform" so called, centering
their interest in the conditions for flexibility as the most
desirable characteristic in any automobile.



# Automobile Board of Trade Active

## Will Work for Good of Membership in Patent Matters

*General Manager Bonnell, in an interview with THE AUTOMOBILE, is authority for the statement that the newer organization, in taking the place of the old A. L. A. M., expects to work for the general good of the automobile industry, but that its plans are more or less passive, excepting that there is some activity in patent matters.*

THERE is some indication of pending patent litigation in the automobile industry. Certain companies holding patents are likely to start litigation, the idea being to impress possible infringers with a due respect for the rights of the owners of patents, as they are prone to claim, but it is the policy of the A. B. of T. to protect its membership from "exactions" on the part of those who may not be as conservative as the claims of their patent specifications might indicate to a man with a clear head and some legal lore. As for the patents that are in the possession of the board, or owned and controlled by the membership, it is the idea to protect the rights that belong thereunder. The board may also extend its domain in the realm of patents.

As a general proposition, according to General Manager Bonnell, it is not the purpose of the board to meddle with any matter that does not come properly before it. While there are a great many things going on all of the time in the automobile business, most of them are in the nature of activities that the respective companies are likely to be in a position to handle without the assistance of the Board of Trade, limiting the activity of the board to the questions that are too broad to be confined to the direction of a single company. As a broad assumption it may not be out of place to expect that the board work will depend upon the measure of benefit that is to be derived from an effort. If the benefit is to be confined to an individual company, that concern will be expected to do the work, but if the benefit promises to be general, it is then to be expected that the board will do the work and shoulder the cost of the effort. Mr. Bonnell states that the general trend of the automobile business is upward and that there is no cloud in sight such as would tingle the sensibilities of a pessimist.

### Preparing for South's Big Road Convention

RICHMOND, VA., July 10—Preparations have just been completed by the American Association for Highway Improvement for the scouting tour of automobiles from Washington to Richmond, which is to pave the way for the big gathering of automobiles, as part of the Good Roads Congress to be held in Richmond, October 30 to November 1. Acting in conjunction with the Touring Club of America, the Highway Association has arranged for this scouting party, consisting of Paul D. Sargent, assistant director of the United States department of public roads; P. St. Julien Wilson, State Highway Commissioner of Virginia; F. H. Elliott, secretary of the Touring Club of America; J. E. Pennypacker, Jr., secretary for the American Association for Highway Improvements, and some of the Washington members of the Touring Club.

At least 500 automobiles will make the trip to Richmond in October to attend the convention of the American Association for Highway Improvements and the congress of its allied organizations.

The plans of the Highway Association and the Touring Club

are to have all tourists from Northern, Western and Northwestern cities to gather in Washington, from which place they will move on to Richmond in an impressive procession. Automobilists from the South, of course, will come to Richmond.

The exposition feature of the convention is already attracting much attention among the manufacturers of road machinery and materials, and requests have been made for more than half the space in the building assigned for exhibits.

### General Bingham Deserts Pavement Job

General Theodore A. Bingham, who made such a fuss as Commissioner of Police that it ended in a legal entanglement involving the Mayor of New York, will be remembered as having impressed Borough President McAneny with his peculiar ability to mend the wretched pavement that has long been an eyesore to everyone, and it comes as a shocking surprise to learn that Bingham has resigned his position as Chief Engineer of the Bureau of Highways, leaving behind him the impression that a few yards of red tape and other forms of official inertia were too much for him to overcome. Bingham, however, seems to think that the Bridge Department will give him something more in keeping with his ability. In the meantime the streets of New York are in a wretched state, and the citizens in general, not forgetting automobilists in particular, have every reason to believe that the whole situation might be mended were some capable man to take charge of the work, one in fine who might persuade himself to use a sharp knife on red tape and persuasion of an effective kind upon opposition.

### Leland Succeeds Henderson as A. B. of T. Director

At the first quarterly meeting of the members of the Automobile Board of Trade, since its incorporation, which was held July 6 at its offices, No. 7 East 42d Street, New York, President Clifton announced that the new organization went into operation on July 1, and had taken over the A. L. A. M. offices.

A meeting of the Directors of the new organization was also held, and W. C. Leland, of the Cadillac Motor Car Company, was unanimously elected to fill the vacancy created by the resignation of Thomas Henderson, who has retired from business.

A number of important matters in connection with the new organization, such as patents and the forthcoming automobile show in New York, were discussed.

### Motor Accessory Manufacturers' Board Meets

A meeting of the Board of Directors of the Motor and Accessory Manufacturers was held at the association's offices, 17 West 42nd Street, New York City, on July 7th, 1911. The following-named concerns were elected to membership: The Allen Auto Specialty Co., American Circular Loom Co., Champion Ignition Co., and the Detroit Carriage Co.

James H. Poster, of the Hydraulic Pressed Steel Company, Cleveland, Ohio, was elected a member of the Board of Directors to fill the unexpired term of the late Mr. W. S. Gorton. H. W. Chapin, of the Brown-Lipe-Chapin Company, Syracuse, N. Y., was made permanent treasurer of the association to fill the unexpired term of the late Mr. Gorton.

## N. A. A. M. and M. & A. M. to Show at Palace

The most important action of the monthly meeting of the National Association of Automobile Manufacturers, Inc., held on Thursday, July 6th, was a decision to conduct an automobile show at the Grand Central Palace, New York, opening on January 10th and closing January 17th, 1912. This show will be open to all manufacturers, and it is known as the result of extensive correspondence carried on during the past month, that practically all of the manufacturers who do not exhibit at Madison Square Garden will take part. It is also practically settled that the Motor & Accessory Manufacturers will take the greater part of the space devoted to that branch of the industry which the association represents.

This show, it will be observed, will run during the last four days of the first week and first three days of the second week of the Garden show. It will embrace both passenger and commercial vehicles, each, of course, in separate departments. This arrangement is made possible by the splendid facilities offered by the new Grand Central Palace.

The building is located two blocks farther north than the old palace, is built entirely of stone and marble, except as to the floors, which are laid on concrete and fire-proofed, and affords 126,000 square feet of floor space.

The method of space allotment will be the same as that at the Chicago show. The executive committee referred all other details to the show committee and the general manager with full authority to proceed.

The Krit Motor Car Co., and Grabowsky Power Wagon Co., were elected to membership.

Favorable action on applications for reinstatement was taken in the cases of Vanderwater & Co., Ltd., Crawford Automobile Co., Warren Motor Car Co., and James Cunningham Son & Co., who took part in an unsanctioned show last winter and were therefore debarred from participation in sanctioned automobile shows.

C. G. Stoddard resigned as the representative of the Dayton Motor Car Co., and Alfred Reeves was elected as representative of that company and to fill the vacancy created on the executive committee.

The membership of Charles E. Duryea was transferred to the Duryea Auto Co., of Saginaw, Mich., and Harry S. Houpt was elected to represent the American Locomotive Co., in place of James Joyce, retired.

The members present at the meeting were: W. E. Metzger, Charles Clifton, Alfred Reeves, L. H. Kittredge, S. T. Davis, Jr., H. O. Smith, A. L. Pope, S. A. Miles, Thomas Henderson, J. W. Gilson, Benjamin Briscoe.

## 1912 Announcements Plentiful in Detroit

DETROIT, July 10—The present month has been featured by a considerable number of factory announcements of 1912 lines, among the most recent of which are those of the Chalmers, Regal and Abbott-Detroit. In all these cases it is a notable fact that the makers have gotten farther and farther away from the old system of building but one chassis, which is equipped with a body variety as great as possible.

The Chalmers Co. will produce three chassis types—the "30," "40" and a new one of 36 horsepower. The last mentioned will be equipped with a self-starter and demountable rims. A four-speed transmission is also a feature.

The Regal Co. will continue its "30" and "40" as well as its underslung "20" roadster. It adds, however, an underslung "35" with a five-passenger body.

The Abbott Co. has supplemented its "30" with a "Model 44" seven-passenger type with a long-stroke motor, 4 1-2 by 5 1-2 inches.

Another company that is enlarging its line for 1912 is the Brush Runabout, which is adding the "Liberty-Brush"—a simpler type than the regular single-cylinder model which has proven so popular for runabout use.

The increased diversity in models is becoming a remarkable feature, as, in addition to those mentioned, the Metzger Motor Car Co. and the Packard have both announced 1912 "sixes" in addition to their regular lines. In fact, of the larger Detroit factories, the Ford, Warren and Cadillac are now about the only ones locally which still stick to one chassis type. None of these companies has made a 1912 announcement as yet. The E-M-F Company branch of the Studebaker corporation really deserves ranking as a fourth in this group, as its two chassis types are put out at separate plants and by separate manufacturing organizations.

## Bergdoll to Head A. M. A. A. Show Committee

The Executive Committee of the Automobile Manufacturers' Association of America which is composed of many of the leading independent makers who are not identified with the new Automobile Board of Trade, held a meeting at their headquarters in the Night and Day Bank Building, corner of Fifth Avenue and 44th Street, on Friday afternoon, when plans for their annual Automobile Show, which will be held in the new Grand Central Palace during the week of January 1, were discussed.

After the meeting it was announced that arrangements had been concluded with the Aeronautical Manufacturers' Association, setting aside the entire third floor of the Grand Central Palace for the exhibition and display of the latest types of aeroplanes with their motors and accessories.

At the conclusion of the meeting it was announced that Louis J. Bergdoll, head of the Bergdoll Motor Company of Philadelphia, had been appointed chairman of the Show Committee and that the other members of the committee would be appointed later.

## Convenient T. C. A. Maps for Motorists

Eight new map sections covering the most popular touring districts of America and which have been compiled under the auspices of the Touring Club of America, are now being distributed among members of the club and other motorists. These maps include in their respective sections, New England, showing all the popular touring routes through Massachusetts, Connecticut, Vermont, New Hampshire and Rhode Island; Maine, with the best routes to Canada; New York with a section of Canada; New Jersey and Pennsylvania, the Middle West, Southeastern part of the country and the Southern States. The maps are compiled on a scale of two miles to the inch and are very legible, mounted on linen, while the mileage distances between various towns and cities situated along the main routes are clearly defined.

## Premier Transcontinentalists' Progress

CHICAGO, July 8—The ocean-to-ocean tourists reached Chicago Thursday and passed Friday here. To-day they headed west again intent on making Davenport, Ia., by night. In the party are thirty-eight enthusiastic motorists, eight of whom are women, who are riding in a dozen Premier cars, while accompanying them are a motor truck for carrying the surplus baggage and a service car. Preceding them and blazing the trail is Ray McNamara, who knows every foot of the road from one coast to the other.

## Miles Spending Dog Days in Maine

S. A. Miles, general manager of the National Association of Automobile Manufacturers, is invading Christmas Cove, Maine, where he will spend nearly all of his time until the end of October. Arrangements have been completed for the show at the Grand Central Palace in New York this year, which undertaking adds materially to the activities of General Manager Miles.

### Five Perfect Scores in Missouri A. A. Run

St. Louis, July 10—Five touring cars finished with perfect scores in the July 4 reliability run of the Missouri Automobile Association. The contestants made unusually good time over the 34.7 miles course. There were two divisions, one for pleasure cars and the other for trucks.

The pleasure car score was:

Car	Driver	Score
Kline	Ashley Gray	Perfect
Selden	H. B. Beguelin	Perfect
Cadillac	Dan Wandell	Perfect
Case	E. L. Colwin	Perfect
Mercer	Charles Kean	Perfect
Firestone-Columbus	John Burns	991
Regal	Roy Anselm	991
Ohio	George Bolz	991
Mercer	R. W. Russell	989
Regal		976
Paige-Detroit	H. M. Paine	949
Ohio	George Mueller	Disqualified
Halladay	Robert Adams	Disqualified
Marion	R. W. Pissell	Disqualified

The score of the trucks was:

Car	Driver	Score
Atterbury	J. C. Summers	Perfect
Federal	R. Stellgis	Perfect
Atterbury	A. Fidler	993
Lambert	D. Perrin	984
Utility	T. H. Goddard	Perfect
Waverly	W. Koeh	996
Atterbury	A. H. Elliott	Disqualified

### Vice-President Henderson Honored

Thomas Henderson, of the Winton Motor Carriage Co., who has for many years been prominently identified with the work of the automobile trade associations, has decided to retire from active business life. He has already resigned his position on the executive committee of the Association of Licensed Automobile Manufacturers and will, on the first Wednesday of September, retire from the executive committee of which he has been a member for ten years.

On Thursday evening, July 6, twenty-five men in the tradé, with whom Mr. Henderson has been prominently identified, held a dinner at the Engineers' Club in New York in his honor, and presented to him a loving cup and an address engrossed on vellum and beautifully bound. The gentlemen present, in addition to Mr. Henderson, were S. T. Davis, Jr., William R. Innis, W. T. White, A. L. Pope, Alfred Reeves, Charles Clifton, W. E. Metzger, S. D. Waldon, George Pope, R. D. Chapin, H. O. Smith, E. E. Bartlett, H. B. Joy, L. H. Kittredge, C. C. Hildebrand, Hugh Chalmers, J. W. Gilson, C. C. Hanch, S. A. Miles, Benjamin Briscoe, M. J. Budlong, R. D. Garden, Wm. Mitchell Lewis, W. C. Leland, Frank Briscoe.

The decorations, in recognition of Mr. Henderson's nationality, were largely of Scotch plaids, thistle and heather. Mr. Henderson, who, until the last moment, had no inkling of the event, was met on his arrival at the club by a Scotch piper in full regalia. The music of the evening also consisted largely of Scotch airs.

The address was presented by Mr. W. E. Metzger, president of the National Association of Automobile Manufacturers, Inc., and the cup by Mr. Charles Clifton, president of the Association of Licensed Automobile Manufacturers. Both gentlemen spoke earnestly and feelingly of the esteem in which Mr. Henderson is held by every one with whom he is acquainted and so did Colonel George Pope and others who followed. Mr. Henderson's response was a masterpiece, declared by every one present to be the finest thing of the kind to which it had ever been their good fortune to listen.

### Stutz Busy Producing Racing Duplicates

INDIANAPOLIS, July 10—The first car built under the direction of Harry C. Stutz performed so encouragingly in the 500-mile International Sweepstakes at Indianapolis on Decoration Day, that the Ideal Motor Car Company of Indianapolis has instructed designer Stutz to duplicate this model as a manufacturing proposition. The Ideal Motor Car Company has a well-appointed

building, three stories high, which was recently erected on Capitol Avenue by Carl G. Fisher. The new organization in addition to designer Stutz includes W. D. Myers as sales manager, and work has so far progressed in the new plant that deliveries are being promised for August 1, offering to purchasers three types of bodies including a roadster, a four-passenger and a five-passenger fore-door type of touring cars. Agencies are being booked, and the indications are that Indianapolis is to be the home of another very active company devoted to the building of automobiles.

### Dead Horse Climb Arrangements Completed

The Dead Horse Hill Climb Committee consists of John P. Coghlin, chairman; J. W. Harrington, Daniel F. Gay, Chester E. Green, and Frederick S. Clark.

A. D. Converse, president of the Massachusetts State Automobile Association, will be referee; Wagner will do the starting.

Contracts have been placed for repairing the hill, which is somewhat down at the heels due to a season of excessively dry weather. In fixing the hill it will be packed with binder such as calcium chloride or Tarvia. Considerable interest is being aroused in this event, and a large number of entries are expected. Among the events scheduled there will be one in Class "A." An amateur event is scheduled for the Worcester County Championship, and another amateur event for gasoline cars only is listed. In Class "B," which is open to any chassis of gasoline cars that conforms to the "stock chassis" rules will be run off. Class "C" will also have its representation open to any gasoline car or chassis under the rules of the Contest Board. A free-for-all event is expected to arouse interest, and there will be two exhibition events, closing the day of sport with motor-cycle racing.

### Willys and Garford Make a Trade Arrangement

It was erroneously reported in some of the trade papers last week that John N. Willys and Arthur L. Garford had joined hands, thus lending the impression that there was a combination of the Overland and Garford plants. George W. Bennett, executive head of the Willys-Overland plant, is authority for the statement that Mr. Garford holds no stock in the Willys Garford Sales Company. The new concern will market Garford trucks.

### Racing Put in Disrepute by Advertising

EDITOR THE AUTOMOBILE:

In the Rayfield Carbureter advertisement of June 22, statement was made: "The 1912 model stock Lozier car, using a stock Rayfield carbureter, finished second, 32 minutes behind the Marmon, having 11 tire changes against 4 tire changes made by the winning car."

This was evidently a clear case of hastily-prepared copy, since the Lozier car finishing second was 32 seconds behind the Marmon.

READER.

### Vale, Lowell; Redivivus, Riverhead

With the announcement that the road race tentatively scheduled for the Lowell, Mass., course for September 23 had been definitely abandoned comes news that an effort is now making to promote a long-distance stock car contest over the Riverhead course. It is the idea of the promoters to stage the event for a Saturday late in September.

### Schaeffers to Make Foreign Tour

Joseph Schaeffers, M. E., member of the S. A. E., is now taking an extensive European trip, during which he will visit England, Germany, Belgium and Austria to observe the progress that has been made in rotary valve and sleeve motors on the other side. He will return in seven weeks.

# British Makers Looking for New Field

## Passenger Automobile Business Falling Off

*According to the latest advices from Coventry, Eng., the British makers of automobiles are in the grasp of sharp competition from the passenger automobile point of view and some of the more important of the companies are branching out. The story, as it is here related, tells how the newer activity is aimed to reach out, invading foreign countries, making the farmers of other lands pay tribute to British acumen.*

A NEW phase of development has now been entered upon by the British automobile industry. The pleasure car business, which has for so many years been the sole support of the leading firms, is by no means the profitable undertaking which it was formerly. There is still, and always will be, a very large demand for touring and pleasure cars, but the gradual drop in power and price—till now the most popular vehicle is the 15-horsepower car at \$1,800—has reduced the manufacturers' profits to a level which is actually serious in its outlook. With this fact before them, the most prominent firms have for some time past been casting around for new lines of profitable business, and passing by the aviation section as useless for yet some time to come, the majority have settled upon the commercial vehicle as the most promising field for future enterprise. As is generally known, the utility motor section has already been well developed in Great Britain, but, so far, a few comparatively small concerns have had the market to themselves, and their limited resources and output have been unable to make full use of the available demand.

One automobile firm to come forward with its fully matured plans is the Daimler Company. This firm, now amalgamated with the Birmingham Small Arms Company, employs over 5,000 men at its two Coventry works. In the present case, the latest designs of commercial vehicle, to be exhibited at the forthcoming

Royal Agricultural Show at Norwich, have attracted general attention throughout the trade.

The chief sections of the Daimler commercial vehicle department comprise the omnibus, the agricultural tractor, and the road train for goods transport. Smaller goods luries—up to 5 tons capacity—are likely to make their appearance in the near future, but at present the actual productions are as stated.

The Daimler motor 'bus has been on the road in its experimental state for over two years. In its final approved form, it has passed the searching tests imposed by the London Police Authorities (the new regulations for 1912 being in every way



Daimler road-train ready to "pull out"

more exacting than before) and the appearance of a fleet of 200 of these vehicles on the London streets is definitely planned for the coming fall. The Premier Omnibus Company, a new \$5,000,000 concern, will look after the operation and control.

On the constructional side, the Daimler 'bus is a radical departure from all previous types. The frame consists of two long pressed-steel girders, joined together by a sheet steel member which also forms the foot-well for the interior body. From the two side members are suspended the duplicate power plants, each consisting of a 15-horsepower Knight motor, a dynamotor, clutch, propeller shaft and worm-driven live axle—this last not extending across the vehicle, but driving its own wheel only. For the equalization of the two propelling units, a buffer battery of some 24 cells is placed at the forward end of the chassis, beneath the driver's seat. By means of an ingenious, yet comparatively simple electrical control, the dynamotors alternately charge up, or take current from, the battery as occasion demands, and all that the driver has to do is to steer the vehicle and to move a single speed-control lever on top of the wheel. When running on the level with full load (36 passengers) the engines are developing about half-power, and the surplus energy is automatically used to charge up the battery till this is at full voltage. Then a solenoid automatically closes the throttles till the power of the engine is just sufficient to drive the bus along at the required speed. As soon as a hill is reached, the solenoid opens the throttles gradually, and, finally, if the grade is too steep for the engines themselves to take the vehicle up at full speed, the battery commences to supply current to the dynamotors, and in this way the requisite extra power is obtained. From the driver's point of view, the control is sim-



Power unit for a long train of luggers

plivity itself, for much less exertion is required than in the case of operating a pleasure car.

Not the least interesting feature of construction is the manner in which a power unit can be removed and replaced by a stand-by set, the whole job being easily effected inside half an hour. The illustrations will show how neat and compact is the general design of the bus, which weighs, complete and ready for running, only 3 tons 8 cwt.

With regard to the new agricultural tractors, these are made in two types—the 100-horsepower, and 30-horsepower. The former is intended for use in such places as Canada, Russia and Argentina, where long plowing runs are required. A 21-disc plow, going down to a depth of 9 inches, can easily be hauled by this big tractor and in addition, the usual range of portable and stationary machine work, in addition to road haulage, is provided for.

#### How the Plan Is Worked Out

The engine is a 100-horsepower 6-cylinder Knight type, running on either gasoline or kerosene at the option of the buyer. Only magneto ignition is provided, on account of the many drawbacks of storage cells in new country; and for starting



How the 100-horsepower tractor looks

purposes a small "pup" engine, one cylinder, air-cooled, is fitted, driving the main shaft behind the flywheel and disconnected when out of use. The main engine is placed right at the rear of the machine, in an easily accessible position. The transmission comprises metal-to-metal clutch, two speed and reverse gearbox, and then worm drive of the countershaft. By this worm drive, using a steel worm and a phosphor bronze worm wheel, a large gearing reduction is easily obtained, with good efficiency. Final drive is by spur gears on the countershaft, which mesh with large gear rings on the main wheels. The total gear reduction is 114 to 1. Roller bearings are used throughout. The direct drive, for ploughing, gives a speed of 2.4 miles per hour, while the indirect hauling speed gives 4 miles per hour.

A large circular fuel tank forms the front of the machine, while behind the funnel comes the radiator. A fan impels air through the latter and, in addition, the engine exhaust is discharged through an injector nozzle up the chimney in such a way that a good air current is induced through the radiator tubes. The water consumption on full load is less than a gallon a day, while the fuel capacity is sufficient for a 12 hours run. The total weight is 11 tons and a draw bar pull of over 12,500 lbs. is given.

The 30-horsepower Daimler tractor has a 4-cylinder Knight engine of 4 inches bore, 5 1-8 stroke, giving its rated power at 1,000 revolutions per minute. In this case, the engine is placed in front beneath the bonnet, and, behind, comes the clutch, three speed gearbox and worm driven countershaft. The direct ploughing speed is 2 1-2 miles an hour; the other speeds give 4 and 7 miles respectively. A wagon body, of two tons capacity,

is provided and a tipping gear operates this when required. This smaller tractor is intended for home use and also for countries like Australia, where comparatively small farms are the rule.

Concerning the road-trains, the third branch of Daimler activity, these were formerly known as the Renard. The Daimler road-trains are in use in Australia, India and elsewhere. California and British Columbia being exploited. The principle of the train is, of course, that the locomotor, in front, does not do any hauling, but just carries the motor which supplies power to a long flexibly-jointed shaft which runs the whole length of the train—usually four wagons or followers being employed. Each follower, by means of a worm-driven gearbox and final claim transmission, drives itself. Each follower is steered by the movement of the vehicle in front. All that the driver has to do is to steer his "loco" in the touring car way, and then, as each wagon reaches the place where the "loco" has left the straight line, it will begin to turn, and then pass on the movement to the next follower. A train of five vehicles can thus be steered over a plank ridge or along a chalk line, without any trouble. This means, of course, that the driver can easily avoid all the bad places on the road. Each wagon can carry 6 to 8 tons and as this load is divided over the six wheels, the maximum axle load is comparatively small. The motor used, it may be noted, is an 80-horsepower 6-cylinder Knight of 4 7-8 by 5 1-8 inches.

#### Wisconsin State Fair Meet Abandoned

MILWAUKEE, Wis., July 10—In line with the general movement to stop racing on mile horse tracks in the United States, the Wisconsin State Board of Agriculture has decided to abandon the idea of holding a race meet on the last day of the Wisconsin State fair in Milwaukee on Sept. 16. It is probable that the Board of Agriculture will not again sanction racing meets on the track. The idea of holding a motor show in conjunction with the State fair will be carried out as originally planned.

#### Warner Mfg. Co. New Plant Finished

TOLEDO, O., July 10—The new plant of the Warner Mfg. Co. here, is nearing completion and the company will have occupancy about July 15. This will more than double their present capacity in sliding gear transmissions, steering gears, differential gears and control sets.



Example of 30-horsepower tractor



## Seen in the Show Window

**A**MONG power pumps used for inflating automobile tires the Rector tire inflator (AQ) is to be mentioned. It consists of a small pump, the plunger of which is reciprocated in its cylinders, utilizing for this purpose the power of the engine of the car itself. The manner of operation is clearly seen in the illustration, in that the pump is actuated by a split gear drive, one pinion being permanently attached to a half-time shaft of the engine, *i. e.*, pump or magneto shaft, while the other is integral with the air pump and if held against its mate on the halftime shaft, serves to impart reciprocating motion to the plunger of the inflator. The pump is made by the Rector Engineering Company, Metropolitan Building, New York.

**A**CETYLENE, in most cases, is bought and transported in tanks under a pressure which sometimes reaches two hundred pounds. Naturally, as the supply is drawn upon, this gas pressure falls off, and it would be fair to expect that as the original pressure of the gas current is diminished, the flow and consequently the height and illuminating power of the flame fall off too. On the other hand, the pressure while the tank is full, or nearly so, is much higher than would be necessary to produce a flame of proper height and strength. To solve the problem of furnishing an unaltered amount of acetylene under the same pressure at all times, a regulating device has been placed on the market. This is the Simplex gas regulating valve (AR) made by the Champion Igniter Company, 585 Boylston street, Boston, Mass. The adjustment of the regulator is accomplished by turning the revolvable piece of the device to one side or the other, thereby opening or closing an orifice to a varying degree, automatic regulation being a further consequence of this operation.

**V**APORIZING the less volatile constituents of engine fuel is a complicated task, but in the construction of the Universal hydrocarbon gas producer its makers claim to have made a step toward the final solution of the problem. The device mentioned (AS) is 5 inches in diameter, its length varying in proportion to the power of the engine to which it is applied. In the producer the fuel is first atomized, and then drawn by engine suction through pipes heated by the exhaust gases, so that a complete vaporization of the liquid parts is effected. A very high fuel efficiency is claimed for the device by the Universal Oil Converter Company, 227 Borden avenue, Long Island City, N. Y.

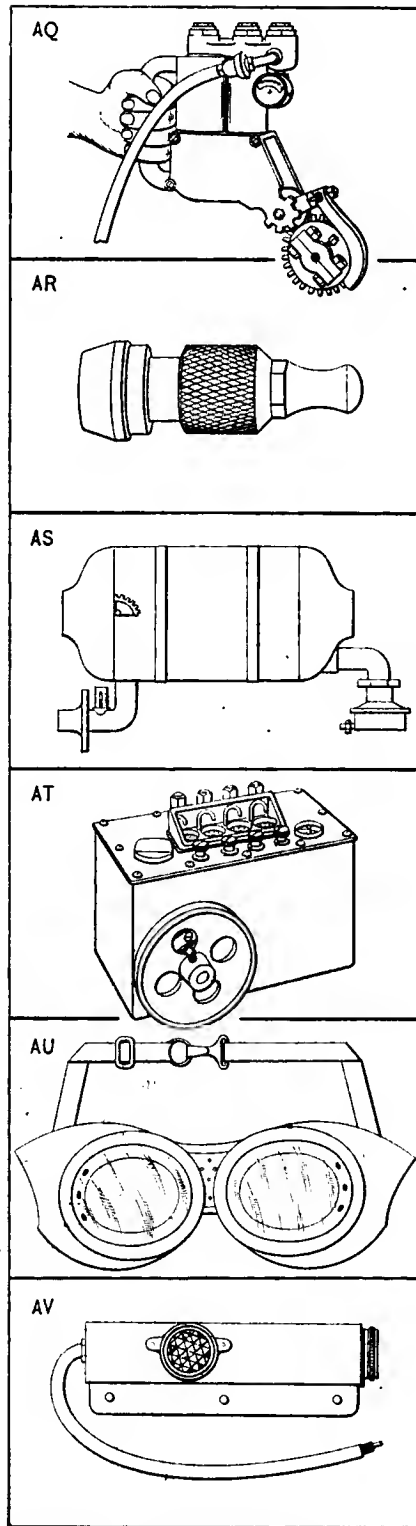

AQ—Rector Tire Inflator is driven by the engine  
 AR—Simplex Regulating Valve for acetylene lighting systems  
 AS—The Universal Producer for vaporizing hydrocarbons  
 AT—Detroit Mechanical Oiler, an up-to-date force-feed system  
 AU—Cover rubber goggles protect and ventilate the eyes  
 AV—Adlake lamp for illuminating rear license number

**W**ELL-LUBRICATED cylinders represent a desirable condition in an engine, and since the safest way of gaining one's end is by applying force, this principle has proved to work out well in the case of gasoline engines, where force-feed systems were used to introduce into the cylinders the oil necessary to insure smooth running. One of the well-known mechanical systems is here shown, this being the Detroit oiler (AT). Like most force-feed systems it is worked in connection with a circulating pump, the oil from the reservoir being forced through the mechanical oiler box seen in the illustration, whence it flows through individual leads to cylinders and bearings supplying all of them with the proper amount of lubricant. The type of oiler here shown, in several sizes to fit the various sizes of engines, is sold by the makers, the Detroit Lubricator Company, Detroit, Mich.

**E**YES, like eyeglasses and telescopes, are valuable instruments and deserve to be cared for and protected against dust and rough mechanical influences in at least the same measure as the artificial devices named above. At the same time the use of eyes cannot be dispensed with and the protecting case must be so made as not to interfere with the sight of the owner of the eyes. Another point to be carried in mind is that to be in proper working condition the human eye requires a certain amount of ventilation, all of which must be considered in the construction of good automobile goggles. The Cover rubber goggles (AU) are made of soft rubber and perfectly transparent material so as not to handicap the correct functioning of the eye in any way; the breathing feature is also incorporated in this device by means of air holes placed in the rubber in advantageous locations. These goggles are handled by Sussfeld, Lorsch & Company, 37 Maiden Lane, New York.

**C**ONFORMING with the laws in most States, the automobilist is required to illuminate at night the number on his rear tag, and for this purpose the Adlake license number illuminator shown at (AV) it well adapted. It consists of a full-length reflector, sliding bottom glass and red jewel. One end shows white light, while the other serves to house the electric connection. Heavy brass is the material used in the manufacture of this lamp, and it may be of interest to know that any desired finish is supplied by the makers, the Adams & Westlake Company, of 319 West Ontario street, Chicago, Ill.

# THE AUTOMOBILE

## Owners Awakening to Body Needs

### A Place for Apparel Is in Brisk Demand

*Sentiments voiced by many readers of THE AUTOMOBILE are distinctly in favor of definite lines of thought founded upon the necessity of providing certain conveniences that are not found in bodies for automobiles. It seems to be true also that the tires and tools, not forgetting the battery, should be placed inside of the car, and it is the purpose here to show that automobiles may be so designed that there will be a place for everything, even the chauffeur.*

mention would have to be made of the fact that bodies as they were applied to automobiles were lacking in many respects from the point of view of the newer service, and it is to the ingenuity of owners of automobiles that we may trace the practice of loading down the running boards, and the placing of needed facilities at convenient spots over the exterior surfaces of the bodies of automobiles.

In the carriage-makers' time the coachman and the footman had their own domain, and they were provided for according to their needs, and in keeping with a certain ethical situation. When

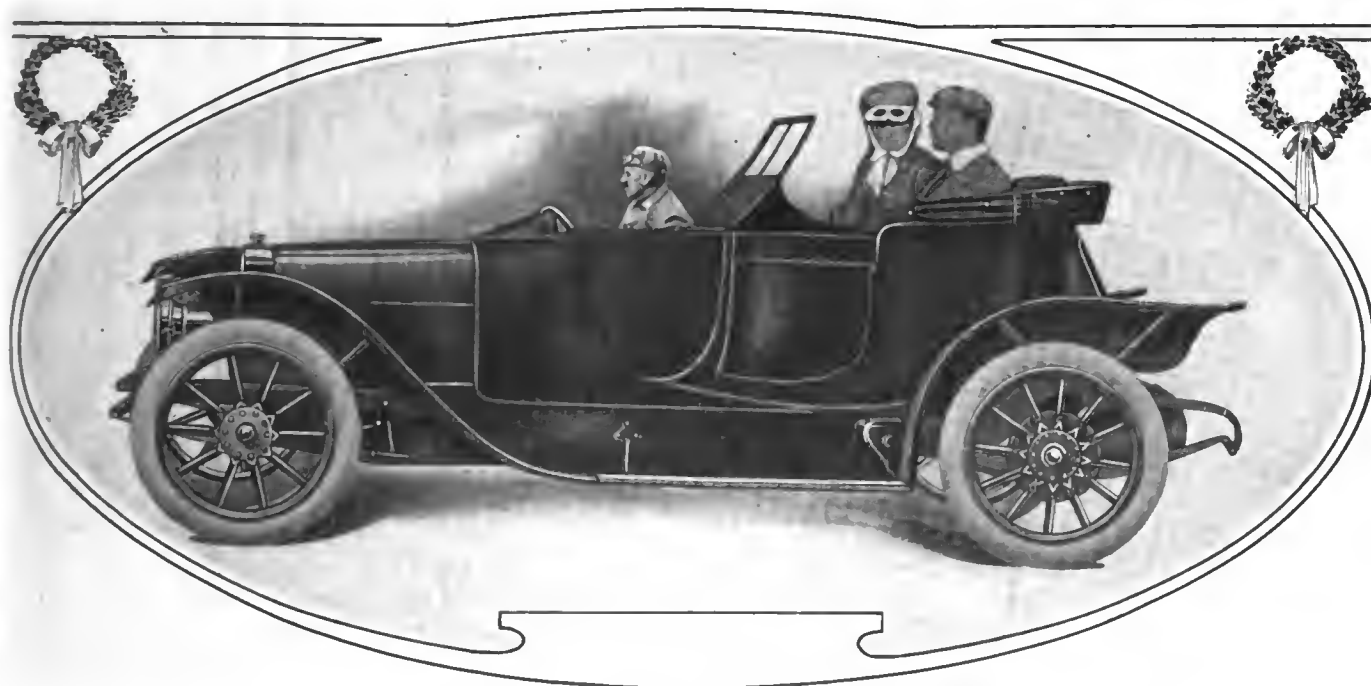

Fig. 1—Side elevation of a new type of automobile body providing a pit for the chauffeur and a separate steering equipment in the tonneau for the convenience of the owner

**B**ODY MAKING, as it applies to automobile construction is an evolution of the carriage-makers' art. Carriages in the old days were not used for touring, due to the fact that horses were incapable of covering distance on a touring basis. The covering of considerable distances by automobilists introduced a new set of requirements, but there is a certain lack of harmony between these new requirements and the manner in which they are being coped with by the men whose experience was founded upon the carriage-makers' idea of the fitness of things. In a recount of the growth of the automobile industry

the automobile came into vogue the footman was dispensed with and the coachman was supplanted by a chauffeur, so called, to accord with the newer need. The chauffeur, in addition to directing the movements of the automobile, was supposed to have a certain measure of mechanical skill, and when automobiles first came out it is more than likely that the requirement of mechanical skill greatly exceeded the demand, measuring the capability of the mere driver. When the chauffeur pre-empted the best seat in the body of the automobile, and held it against all comers, the signs of revolt on the part of the other occupants of

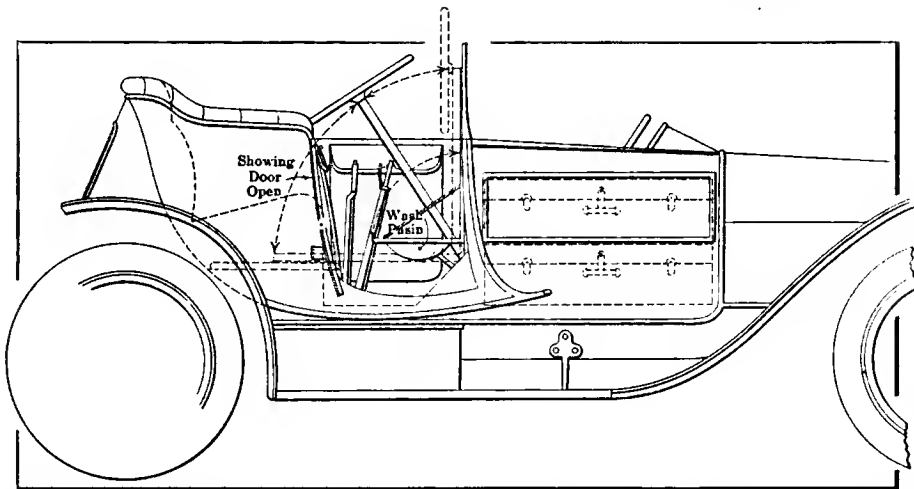

Fig. 2—Right-hand side of the new body, showing the storage of suit cases alongside of the chauffeur, the arrangement of the owner's steering gear in the tonneau, and a folding wash-basin taking water from a tank suitably disposed in the compartment in front

the car were too feeble to attract attention, but a change is coming over the field of automobiling, due to the fact that the mechanical skill idea is no longer a pressing necessity, and as matters stand to-day the best type of chauffeur is represented by the fellow who will have the good sense to keep the automobile clean, replenish the supply of gasoline and lubricating oil, keep the tires inflated, and drive the machine conservatively.

But the chauffeur still sits in the best seat in the automobile, and this fact, instead of being traced to the necessities as they obtained in the past, is the price of lack of ingenuity on the part of designers of bodies, in the face of persistent complaint that is well founded. When the owner of a car invests the best part of \$5,000 in an equipage he will have great difficulty in getting a satisfactory return upon this investment if the work that the automobile does is confined to the mere effort of taking him to his office in the morning and back again at night, together with an occasional jaunt in which the owner's family may be permitted to join in the sociability, but there is a distinct expression of dislike on the part of many owners of automobiles, founded upon the experiences of the past, resulting in greas-smear'd ladies' costumes and affronted sensibilities, without rea-

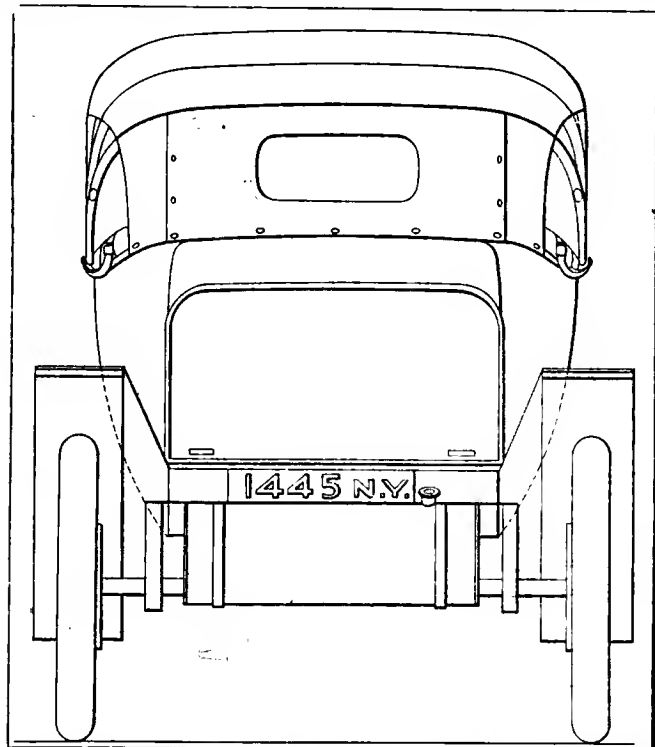

Fig. 3—Rear elevation of the body on a Guy Vaughan chassis, showing the trap door through which access may be had to the tires and tools as they may be stored within

sonable ground for objection, since, in all fairness, the chauffeur must be given a place of his own if he is not to occupy a position in the part of the car that is to be devoted to the service of the owner. As a parallel case, the owner of a steam yacht is freed from the objections of contact with the men who work around the machinery thereof, and, for that matter, the engineers who do the work enjoy the advantages of privacy, but this happy situation is at the expense of providing a place for the workmen as well as a place for the owner.

In town car work, since the mechanic has a seat of his own in a position of vantage, those who enjoy the pleasures of this type of car are in a position to voice strong sentiments in favor of the embodiment of the same idea in

types of automobiles that may be devoted to long-distance traveling, and it is from this class of the owners of automobiles that the best information comes, they being strongly in favor of providing a seat for the chauffeur and a compartment for the storage of such wearing apparel as must be taken along if a tour is to be under the most pleasurable conditions. When the automobile ranked as a novelty pure and simple there were not so many objections to tourists who might come into the dining-room of a first-class hotel looking like tramps and, to say the least, unkempt; but public opinion is decrying these conditions, and the time will no doubt arrive when tourists will be expected to repair to a room and make a change of costume before appearing in a dining room and in the public parlors of well-kept hostleries.

For the purpose of showing that it is within the realm of possibility to so design an automobile that there will be a place for everything, including the chauffeur, Fig. 1 is offered, presenting the general appearance of the automobile, in which it will be seen that the chauffeur is given a position on the left-hand side of the body, bringing the side levers on the fore and aft center lines, and the steering wheel so low down that the occupants of the owner's seating space would scarcely be able to observe that there is a chauffeur in the car.

The space alongside of the chauffeur is taken up for the storage of suit cases, and a study of Fig. 2 will suffice to indicate the scope of this arrangement, showing two suit cases in the compartment with some space above them for the storage of rugs, coats, etc. Fig. 2 also shows the entrance to the tonneau as it is provided at the right-hand side, bringing into view a new idea which may be briefly described as follows: Remembering that nearly every owner of an automobile has a penchant for driving, and taking into account the fact that the owner would not care to go down into the chauffeur's "pit" in a car of this design, it is a part of the plan as here contrived to equip a tonneau with a master wheel, side levers and the other facilities essential to the control of an automobile, with a means whereby the owner can unship the chauffeur's steering gear and take charge of the driving of the automobile without further ado.

#### A Place Is Made for the Storage of Tires and Cases, Also for Tools

When the owner gets tired of driving he may reshup the chauffeur's gear and instruct him to undertake the responsibility of driving. In order, however, that the steering column as provided for the owner in the tonneau might not prove discommoding in certain respects, it is provided with means and mechanisms for folding back out of the way, thus leaving it entirely optional with the owner of the automobile to drive or not as he will, or to remove the evidences of his driving facility, and take advantage of the extra space afforded thereby.

The back of the car is shown in Fig. 3 with the gasoline tank

attached to the chassis frame, and the license number with means for illumination at the back taken care of as a part of the design of the automobile. Referring to Fig. 4, which is a plan and elevation of the new design, it will be seen how two spare cases are stored in a compartment within the body lines above and slightly to the front of the rear axle with access to these cases through a trap door at the back of the body. In addition to the storage of cases in the back compartment there is room for tools and the design contemplates a definite position for each tool required, and a method of fastening the same into its place so that it cannot go adrift or make noise. Moreover, the arrangement is such that the owner of the car can see at a glance if there is a single tool missing from the kit. With the tires and tools provided for in the back compartment and a Yale lock on the trap door, nothing is left to chance in this quarter, and a considerable measure of the touring responsibility, especially of the harassing sort, is done away with. The space at the front on the right-hand side for the accommodation of two suit cases provides for a regulation size of cases 9 inches deep, 18 inches wide by 33 inches long: this space is dust-proof, and suitably lined with means for fastening the cases down so that they will not rattle and become chafed. In addition to the provision for suit cases and the storage of rugs and coats a water-tank is provided and a folding water-basin is also fitted into place with means for opening the same back into the tonneau. This basin is

shown in the open position in Fig. 2, it being contrived in substantially the same way as the folding basin of this character in Pullman compartment cars. In the illustration Fig. 4 provision is made for a searchlight, the latter being back of the dash line, convenient to the chauffeur, with means for hand-control. It is the idea in connection with this body to use electric lights with a dynamo for generating the electric current, suitably attached to the automobile motor. It would be optional to use the searchlight; it may be removed at will, and Fig. 1 shows the body in elevation with the searchlight removed.

**MOTOR LAWS IN NEW BRUNSWICK**—The New Brunswick Legislature has enacted some laws which are of interest to automobilists who reside in or drive through that province. Here are some of the stipulations: A chauffeur's license may be canceled after two convictions. A higher standard of brilliancy of lamps is necessary. Car numbers must be 4 inches high, instead of 3 inches, as formerly. The motor car speed has been reduced to 20 miles per hour. Some members of the Legislature from the country districts introduced resolutions of a decidedly freakish nature, one of which demanded that cars should not be used on one day in each week. The amendment was shouted down. A tax, which will be given over for the improvement of the roads of the province, was approved, this tax ranging from \$5 to \$25 on automobiles of from 25 to 50 horsepower.

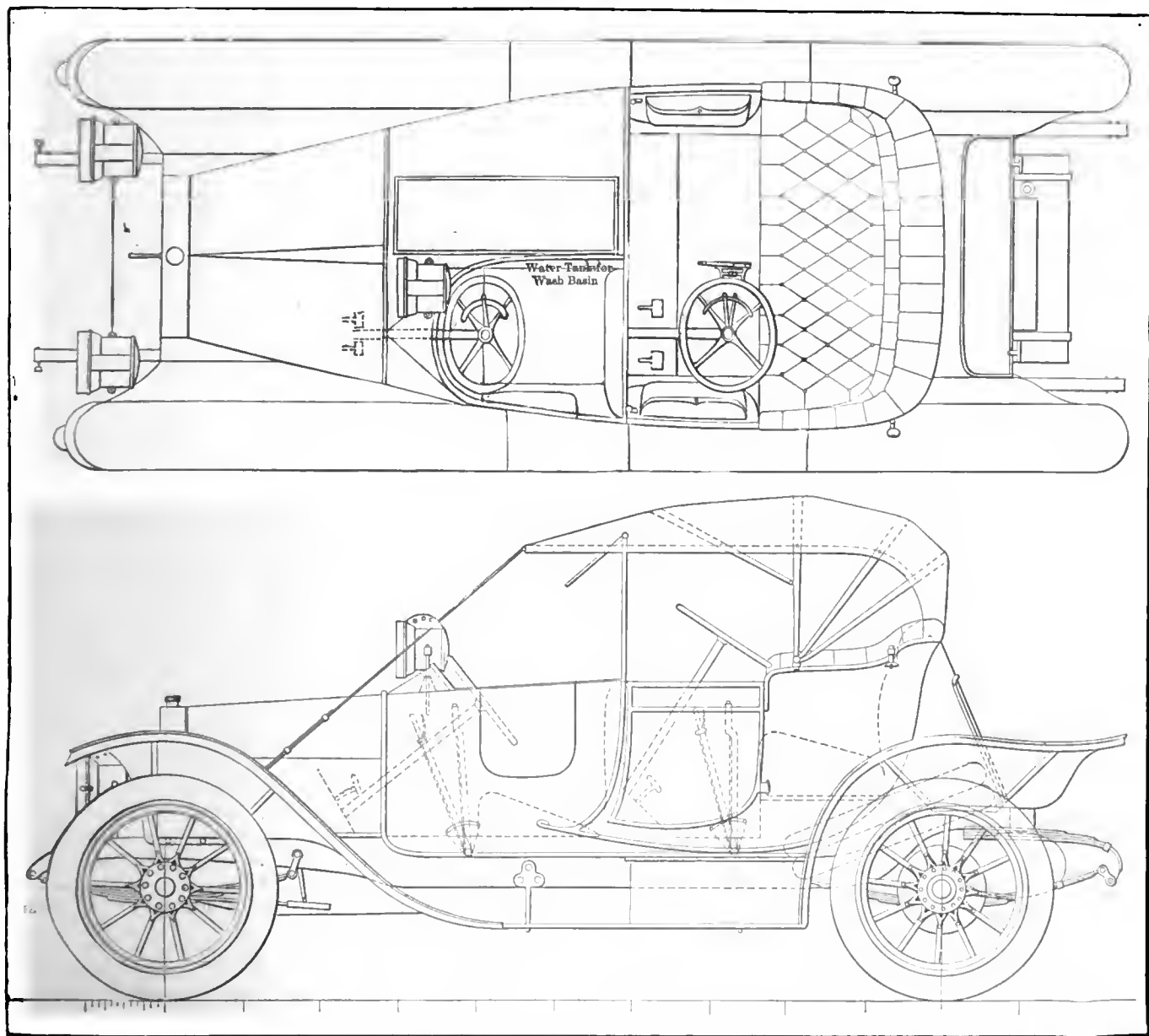
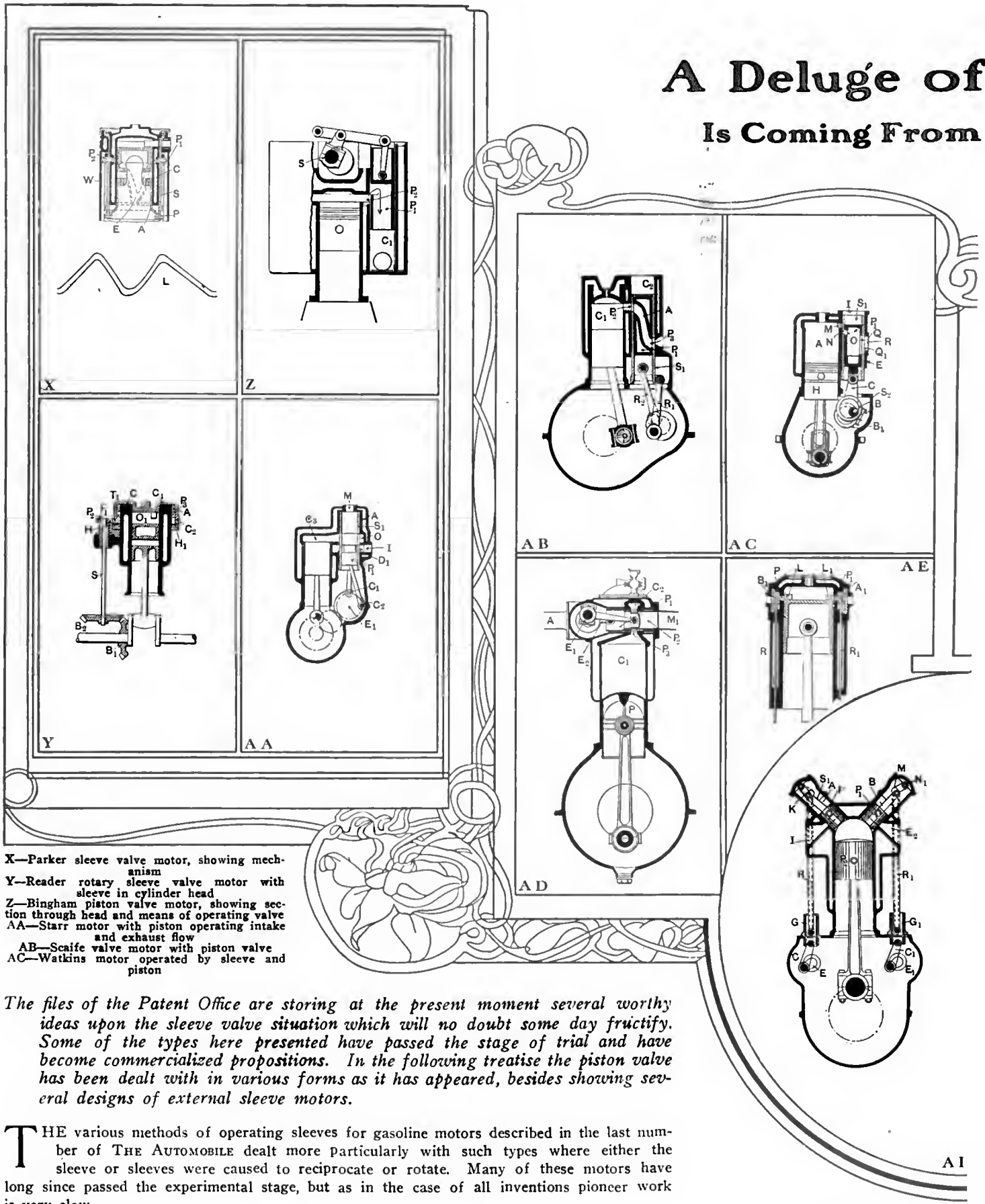

Fig. 4—Plan and elevation of the new body, showing the double steering equipment in dotted lines, also the storage of tire cases. The sealed compartment for suit cases is at the right of the driver's pit

# A Deluge of Is Coming From



X—Parker sleeve valve motor, showing mechanism  
 Y—Reader rotary sleeve valve motor with sleeve in cylinder head  
 Z—Bingham piston valve motor, showing section through head and means of operating valve  
 AA—Starr motor with piston operating intake and exhaust flow  
 AB—Scaife valve motor with piston valve  
 AC—Watkins motor operated by sleeve and piston

The files of the Patent Office are storing at the present moment several worthy ideas upon the sleeve valve situation which will no doubt some day fructify. Some of the types here presented have passed the stage of trial and have become commercialized propositions. In the following treatise the piston valve has been dealt with in various forms as it has appeared, besides showing several designs of external sleeve motors.

THE various methods of operating sleeves for gasoline motors described in the last number of THE AUTOMOBILE dealt more particularly with such types where either the sleeve or sleeves were caused to reciprocate or rotate. Many of these motors have long since passed the experimental stage, but as in the case of all inventions pioneer work is very slow.

### Parker Uses a Somewhat Complicated Method

The section of the Parker motor, Fig. X, shows a cross-section of one of the cylinders in which A is the working piston and B the outer sleeve which is placed between the external

AD—Drummond and Bostock motor, showing operation of piston valves  
 AE—Cylinder of Wridgway motor showing method of operating sleeves  
 AI—Royce valve motor, showing overhead piston valves



# Sleeve Motors

## Every Nation

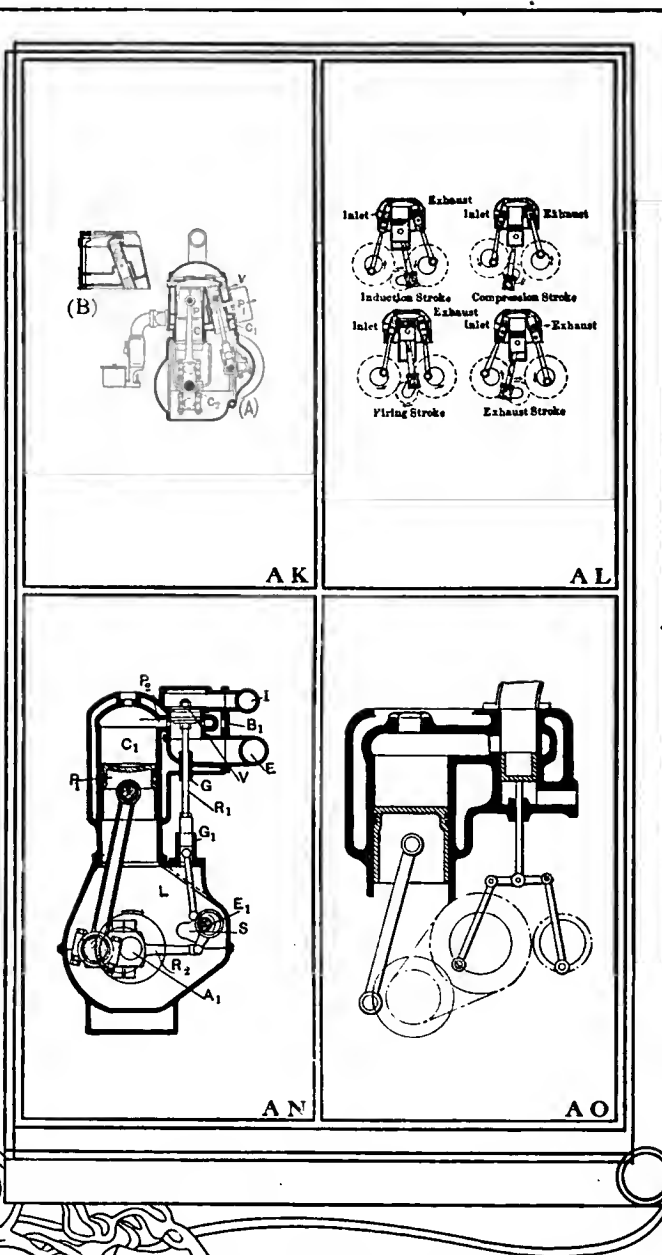
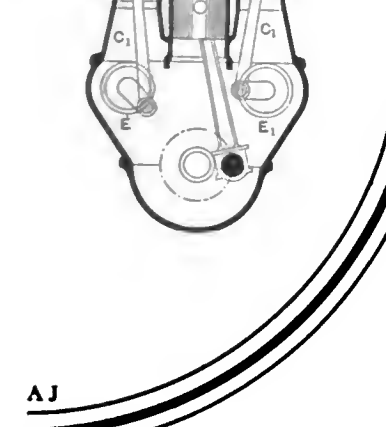
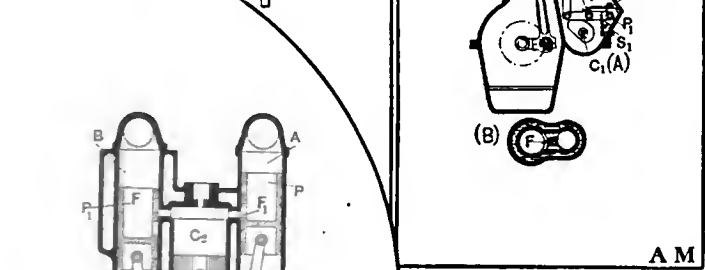
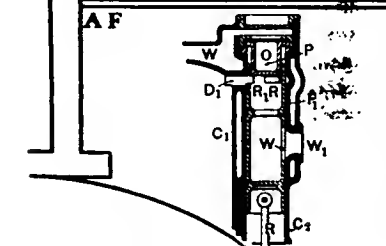
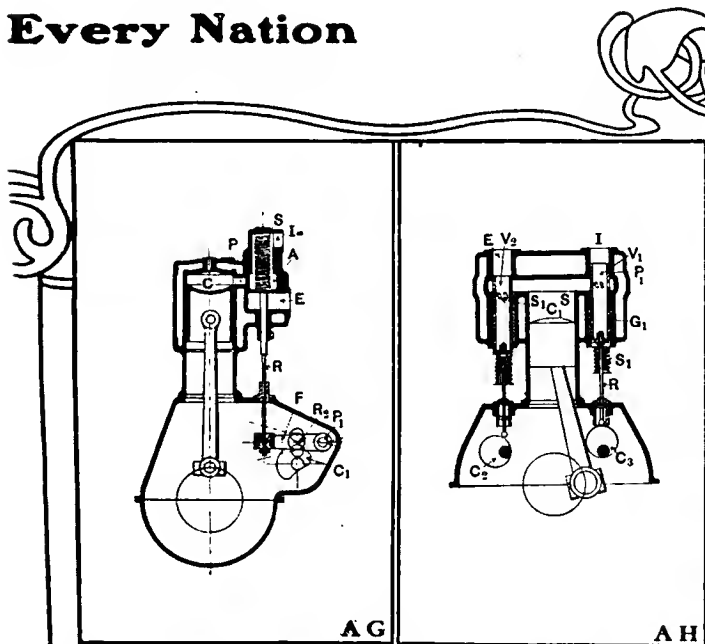

AJ—Bingham motor with piston valves, operated directly from below  
 AK—Section of Hewitt piston valve motor  
 AL—Diagram showing cycle of operations of Hewitt piston valve motor  
 AO—Section of Pieper piston-valve motor  
 AM—(A), Smith single-piston valve motor. (B), plan section of Smith motor, showing working and valve cylinders  
 AN—Mann piston valve motor shown, single piston for intake and exhaust

wall and the water cooling space C. At the base of the piston P the working piston and the sleeve are joined together so that with the reciprocating motion of the piston A the sleeve is forced to reciprocate as well. The semi-rotary action of the sleeve is obtained by fitting the sleeve with a pivot P<sub>1</sub>, which engages in a slot in the exterior wall W. The slot is indicated by dotted lines with a lower apex at E. The longitudinal section L shows how the wall W is slotted in order to accommodate the pivots P<sub>1</sub> and P<sub>2</sub>. It is a question whether the power required to guide the pivot in the slot will not take away from the general efficiency of the motor.

### Reader Motor Employs Rotary Valve in Head of Motor

Another form of rotary sleeve valve motor is shown in Fig. Y, being the composite production of F. J. Reader, A. E. Taggard and E. A. Wilderspin. The mechanism consists of a rotary valve A which surrounds the cylinder C, the valve having a port or ports adapted to register in rotation with the inlet and exhaust ports of the motor. The valve A at the outer end of the cylinder C surrounds the cylinder; the rotary motion is imparted by

AF—Section through valve in Foster motor, showing port  
 AG—Section through Brindley motor, showing method of operating piston valve  
 AH—Mascord motor utilizes two cylindrical sleeves placed parallel to working cylinder

bevel gear set B1 and B2 and thence by a vertical shaft to the pinion P1. This pinion is clean on the upper end of the shaft S and meshes with the teeth T1 formed on the lower end of the valve A. The cylinder C1 has a downward protruding flange C2 which surrounds the valve A, so that the main part of the valve lies within an annular space between the flange and the cover of the cylinder. Adjustable lock nuts are provided on a screwed portion of the cylinder for adjustment of the valve ring, and ball races H and H1 are interposed between the lock nuts and the lower edge of the flange. Ports P2 and P3 are provided in the valve ring A which uncover the cylinder ports O1.

#### Bingham Piston Valve Motor Has Good Points

The adaptations of the sleeve are legion and at a later date further applications of this type will be given. A type of motor that has been placed on the market commercially and which deserves more than passing mention is what is known as the piston valve motor. This school has several adherents and the methods of operating the piston are numerous. Some favor an overhead motion, others using the conventional eccentric shaft. One type that has been practically demonstrated in England is the Bingham piston valve. As shown in the illustration this is operated by an overhead eccentric shaft S1 and is rotated at one-quarter crankshaft speed, as the rectangular ports in the valves open to the cylinder ports on the down stroke as well as on the up stroke. A section of the motor is shown in Fig. Z. The piston P1 is caused to reciprocate in the cylinder C1, covering and uncovering the port P2 of the cylinder. During the power stroke the valves are not in lateral balance, and the surface of the valve subjected to the explosion pressure is equal to the area of the port. But as will be seen from the illustration the valve is very long; the thrust from the explosion is distributed over a considerable surface area. This motor has been modified in some respects and the valve operation has been effected by means of a connecting rod operating the piston from below.

#### Starr Motor Uses Sleeve and Piston

In the Starr motor the valve mechanism consists of a sleeve, shown in Fig. AA, inside a small cylinder A, and inside the sleeve there is a piston P1, both being operated from the eccentric shaft E1 by connecting rods C1 and C2. The piston P1 has 90 degrees advance of the sleeve S1. The eccentric shaft is driven at half speed of the crankshaft. The combustion chamber C3 is brought into communication with the intake and exhaust manifolds through the office of the sleeve S1 and the piston P1. The exhaust manifold is attached at M, and the intake I is provided with an annular cavity D and another cavity D1. As the sleeve S1 is drawn downwards the piston P1 moves upwards, and gives free entry to the intake. In a similar manner the upward motion of the sleeve S1 and the downward motion of the piston P1 the upper half of the piston uncovers the port slot and gives free egress to the exhaust.

#### The Skaife Motor Uses a Channel Piston As Well As a Sleeve

The Skaife motor is shown in section in Fig. AB and alongside the main cylinder C1 there is a cylinder C2. The sleeve S1 is operated by the connecting rod R1 set at 90 degrees to the connecting rod R2 which operates the piston P1. The eccentric shaft runs at half speed and the operation of intake and exhaust is similar to the preceding type with the exception that the intake is effected in the manner shown in the illustration. The piston P1 has a double-elbow passageway which connects the ports P2 and P3. As the sleeve mechanism is housed with the crankshaft no supplementary lubrication is necessary.

#### Watkins Motor Is Well Thought Out

Fig. AC is a cross-section of the Watkins motor (British Letters Patent No. 650). The valve cylinder E at the side of

the working cylinder A contains a sleeve S1 which is adapted to reciprocate therein. The sleeve is operated by eccentric rods B and B1 which are mounted on the half-speed shaft S2 by means of sheaves. The half-speed shaft is driven in the usual manner by gear wheels. Fitted concentrically inside the sleeve valve S1 is the piston valve P1 adapted to reciprocate within it, being operated by the connecting rod B. M is the port opening into the working cylinder A. N is the port in the outer piston valve S1 communicating directly with the port M. O is the port of the piston valve P1 registering with the port N. I is the intake manifold connection. The port Q of the piston valve P1 and the port Q1 of the piston valve S1 are always open to the exhaust port R. The section of the motor shows the relative positions of the two piston valves and their ports on the working cylinder. The working piston H is at the bottom of the stroke, following the explosion stroke, and the ports N and O have just opened to allow the exhaust gases to pass through to the exhaust outlet R.

#### The Bostock and Drummond Motor Is Controlled by Horizontal Pistons

In the Bostock and Drummond motor, shown in Fig. AD, it will be seen that the piston valves are operated horizontally in the head of the cylinder C1. A is the inlet manifold connection to which the carbureter is attached and the illustration shows the eccentric shafts E1 and E2 operating the valves P1 and P2. The piston valve P1 is slotted and the same applies to the piston valve P2 so that the port P3 in the head of the cylinder becomes uncovered and allows the incoming gases to be sucked into the cylinder C1. It will be noticed that the piston P is of the spherical dome type. As the piston P rises on the exhaust stroke the piston P2 recedes inside the sleeve P1, allowing the port P3 to be uncovered and the exhaust gases to be expelled through the manifold M1. In order to facilitate the quick flow of incoming and outgoing mixture the cavity C2 is provided in the cylinder head. The sleeves are cooled by incoming gases through the manifold way, but this may have a detrimental effect upon the lubrication of these parts.

#### Sliding Block Sleeves Are Used on the Wridgway Motor

The construction of this motor is clearly shown in the illustration Fig. AE and is the invention of C. G. Wridgway. Two sliding blocks operated by rods R and R1, which are caused to reciprocate by a double eccentric shaft, open and close the ports P and P1, according to the four-cycle principle. As in most motors, there is a certain amount of pressure upon the sleeves during the explosion stroke. It has been the endeavor in this motor to overcome this by extending the piston head into two lobes L and L1, and the position that these occupy is shown in the illustration.

#### Foster Uses Separate Piston Valves for Intake and Exhaust

In the sectional elevation of the Foster motor, as shown in Fig. AF, this motor is of the single-acting piston valve type, the valve P1 in the axial line showing a portion of the working cylinder C1. The cylinder C2 of the valve is water-jacketed as shown; the port D1 leads from the combustion chamber to the piston valve. P is a stationary piston fitting within the upper part of the reciprocating valve P1. The interior space O inside the hollow stationary piston P is open to the water jacket W. The connecting rod R is operated through an eccentric shaft running at half engine speed. The valve P1 controls either the outlet of the exhaust gases or the inlet of the new charge. The port W of the piston valve is always open to the outlet port W1 in the valve cylinder wall. The ports R and R1 are placed around the valve instead of on one side only, and in the position shown in the illustration the valve is fully opened.

### Brindley Adds Complication to Present Practice

In Fig. AG will be seen a motor designed by John Brindley, the principal points of difference between this and other piston valves being that springs are used and the reciprocating motion is obtained through the employment of cams. The piston valve A is operated by a push rod R, which in turn receives its motion from the fulcrum lever F. This is attached at one end to the pivot P1. Within the lever F there is a roller R2 which contacts with a cam C1, and as this is rotated by means of intermediary gearing the piston valve is caused to reciprocate. The spring S holds the roller R2 in contact with the cam C1 so that on the downward stroke the roller follows the cam formation. As the roller passes over the hollow of the cam the valve A uncovers the port P and allows the gases to be sucked through the intake manifold I into the cylinder C. The upward motion of the piston valve again uncovers the port P after the explosion stroke and allows the exhaust gases to be emitted through the exhaust manifold E. The motor works on the ordinary four-cycle principle. One point about the disposition of the exhaust manifold and the relation of the piston A1 is that the gases pass through the port P, while the valve A is entirely out of the line of trouble.

### Mascord Utilizes a T-Shaped Cylinder with Two Valves

The accompanying illustration Fig. AH shows a sectional cut of the Mascord motor, in which the valves are provided on either side of the cylinder C1. The valves V1 and V2 are operated by cams C2 and C3. The inlet valve V1 is a cylinder closed at the lower end, and having its upper extremity fitted with piston rings, P1. The lower part is closed and is connected to a rod R. A gland G1 surrounds the lower part of the cylindrical valve, by which the pressure for one or a number of split packing rings may be adjusted, so as always to maintain a gas-tight joint between the lower part of the casing and the lower part of the cylindrical valves. A spiral spring S1 is mounted between the gland and the boss on the rod R1, maintaining uniform pressure. The intake manifold is attached at I, and the exhaust at E. The slots S and S1 in the cylindrical valves allow the gases to pass through them into the respective manifolds.

### Royce Favors Overhead Piston Valve

The section of the motor shown in Fig. AI is of the design of Royce, manufacturer of the Rolls-Royce car in England. Two overhead pistons are employed, P and P1, working in cylinders A and B, located on the right and left-hand side of the combustion chamber. The pistons are provided with piston rings and are operated from eccentric shafts E and E1 through connecting rods C and C1, vertical push rods R and R1 and a link motion L. The piston valves work at half speed of the crankshaft. The shaft S1 lies in the center line of the auxiliary cylinder A so that at the time of the explosion vertical pressure is transmitted to the lever system. The operation of the engine is as follows: After the piston P2 has reached the top dead center, the piston sleeve A opens the inlet port I, keeping it wide open during the suction stroke, and closing it at the beginning of the compression stroke. The levers S1 and K then take dead-center position in the auxiliary cylinder at the moment the explosion takes place. After the working piston P2 is about to reach the lower dead center, the sleeve P1 opens the port E2 and the exhaust gases are expelled. To add greater rigidity to the lever system the connecting rods C and C1 and rods R and R1 are connected to a cylindrical guide. The lever M is placed externally to the axis N1.

### Another Adaptation of the Bingham Motor

In Fig. Z the method of operating the Bingham motor was shown, with an overhead eccentric mechanism, but in Fig. AJ, which is a section of another type of Bingham motor, the sliding piston valves are operated from eccentrics placed in the crank chamber. The auxiliary cylinders A and B are located

laterally in respect to the main cylinder. The pistons P and P1 are operated by connecting rods C and C1 from the eccentric shafts E and E1. The pistons are fitted with piston rings. The pistons' valves have slots F and F1 cut in them which communicate with the two ports in the head of the cylinder C2. The explosive pressure in this case is not taken by the actuating levers, but by the surfaces of the piston valve. Lubrication of this type of motor is very simple, as the auxiliary cylinders are in direct communication with the crank chamber.

### Hewitt Piston Valve Motor Has Been Used Commercially

The Hewitt motor shown in section in Fig. AK differs from other motors of the piston-valve type, as will be seen from the accompanying illustration, inasmuch as the auxiliary cylinder is placed at an angle instead of parallel to the main cylinder. The four-cylinder motor of this type is cast in pairs, and presents somewhat of a square shape. The inlet and exhaust piston valves are situated together on the left-hand side of the motor. The illustration shows the main piston P in the working cylinder C and alongside it the auxiliary cylinder C1 with its piston V. These valves are operated by connecting rods from a secondary crankshaft driven by gearing from the main crankshaft at half speed of the latter. There are eight valves in all, four exhaust and four intake. Referring to the illustration, the form of the combustion chamber will be noticed, and upon the firing stroke the pressure of the explosion moves the exhaust valves three-fourths of their outward stroke until the piston V uncovers the port P1, thereby delivering power through the half-time gear wheel to the main crankshaft C2, which will correspond to an increased expansion of the charge of approximately 20 per cent., but deducting the low efficiency of the half-speed lay crankshaft, the net increase of power should be in the neighborhood of 10 per cent. The cycle operations of the valves of this motor are shown in Fig. AL, the valves being placed on either side of the working cylinder for simplicity only. Fig. (B) in Fig. AK shows a cross-section through one of the intake valves.

### Single Piston Is Used on the Smith Motor

Fig. AM (A) shows the manner of operating the piston valve of the Smith motor by means of a camshaft C1 and a lever L1 which is fitted in one extremity to a pin P1, and a roller R1 contacts with the cam. The roller is held in contact with the cam by means of a spring S1. The piston valve P is moderately moved from the path of the exhaust gases during the exhaust stroke and works in a water-jacketed cylindrical valve chest, controlling a single admission and exhaust port B. During the suction stroke the combustible mixture is admitted to the working cylinder by the upward movement of the piston valve P which uncovers the port B to the inlet port P1. Upon the completion of this stroke the piston valve has attained the position shown in the illustration. At the beginning of the exhaust stroke piston valve P descends and uncovers the port B, thus permitting the exhaust gases to be driven out to the port P2. The lower inner face of the port B at the end adjoining the piston valve chamber is made higher than it is at the other end next to the working cylinder, in order that the exhaust gases passing through the port may be deflected upwardly away from the end of the cylinder. In order to accommodate the rings with a good seal, the piston valve P the metallic bridge F is formed of the same material. This prevents the ring of the piston valve from chattering the port. The bridge is hollow, and its interior is in direct communication with the water cooling system in order to maintain it at a uniform temperature. This is shown in (B) of Fig. AN.

### A Simple Adaptation of the Single Piston Valve

The sectional cut of this motor, which is the invention of Henry Berry and G. H. Mann, shown in Fig. AN, works on the conventional four-cycle stroke. The working cylinder C1, wherein

the piston P<sub>1</sub> which has a concave dish reciprocates, has a port P<sub>2</sub>. The valve box B<sub>1</sub>, containing the inlet opening I and the exhaust opening E, is fitted with a single piston valve V carried on a rod R<sub>1</sub> capable of sliding in guides G and G<sub>1</sub>. The lower end of the rod R<sub>1</sub> is connected by means of a pivoted link L to the shorter arm of the bell crank lever strap S situated on the eccentric E<sub>1</sub>. The eccentric shaft is coupled up to the engine shaft by a rod R<sub>2</sub>. By this means the valve V<sub>1</sub> is caused to reciprocate in the valve box B<sub>1</sub> and alternately place the intake and exhaust ports in communication with the cylinder.

#### Pieper Piston-Valve Motor Uses Novel Method of Operating the Valves

The valve consists of a piston which slides up and down so as to put the cylinder port B in communication with either the inlet passage C, as shown in Fig. AO, or with the exhaust outlet D. It has been the object of the inventor of this motor to do

away with cam operation, and in order to obtain a rapid movement of the piston A and periods of dwell while the ports are open, the piston valve rod E is connected to a rocker F, one end of which is connected by a link G to a crankpin on a shaft running at engine speed. The other end of the rocker F is connected by a link H to a crankpin on a shaft running at half engine speed, thereby providing a quick opening and closing with a period of dwell when the ports are open.

CAPE BRETON, Canada, people now own 15 automobiles which were made by an American concern with a factory in Walkerville, Ontario. There is an import duty of 35 per cent. on foreign-made automobiles, to which the agent's commission of 20 per cent. is added. The touring cars of the type just mentioned are sold in Walkerville for \$875, the outfit including windshield, top and lamps.

## What Fuel Costs in Truck Operation Gasoline and Current in Ton-Miles

*Based upon an immense and typical experience in automobile truck operation it is found that the ton-mile cost of gasoline is .0087, lubrication .00304, a total of .01174, while the item of expense for current used in propelling electric trucks is .0317 per ton mile, which, with lubrication at .00086, makes a total cost in this particular of .03256. The two-ton electric and three-ton gasoline cars again demonstrated their economy as against that of the smaller sizes of both types of freight automobiles.*

WHEN the business man decides to investigate the proposition of replacing his horse-drawn delivery and transfer service with automobile trucks one of the first detailed items that presents itself to him for solution is the cost of gasoline for the operation of gasoline trucks and electric current to drive vehicles of that character.

If he has been systematic in conducting his horse-drawn equipment and if proper detailed records of costs have been kept he knows exactly what it costs per wagon-mile to transfer his freight for each of a dozen different factors that go to make up the sum total of cost. If he has carried his records a little further he knows the ton-mile cost for operation and also the ton-mile cost for each item of operation.

There are many business men who have kept such records with care, but, of course, the vast majority have not done so, and all that their records will show is the cost of operation on gross figures. A detailed record of this kind would prove exceedingly valuable to the business man who to-day is confronted with the stringent necessity of changing his system of transfer and delivery. It would form a solid basis for comparison with both electric and gasoline trucks that would help him immensely in getting maximum service from his equipment at minimum cost.

But to go back to the subject: The cost of gasoline and current is one of the salient items of truck operation, just as tires, repairs and supplies also bear an intimate relation to the total.

The following article takes up the cost of gasoline and electric current actually used in the operation of 634 trucks, 412 of them being electrics and 222 being gasoline cars. The figures submitted cover four years of operation under actual service conditions. If anything beside the exact truth, the total figures per ton-mile as given here are a shade too high, because many of the trucks used in the illustration have been in service for several

years and as a consequence are not quite as economical of fuel and current as the most modern types of freight automobiles may be.

However, nothing that approaches the facts and conclusions of this article in the way of exact data has ever been published on this subject. The average mileage of all gasoline cars considered was 28.3 miles per day, including every day in the year whether in service or not. As a matter of fact they were in actual use a trifle over twenty days in each month, the difference between the actual length of the month and the service being accounted for by holidays and lay-ups for repairs, adjustments and other things as well as the general exigencies of business.

The actual mileage of the gasoline cars on working days or days in which they were used was 42.5 miles. This would give a total of 850 miles a month and 10,200 miles a year. It may be well to note that all the cars could have done more service if they had been pressed to do so.

The sizes of gasoline cars considered as far as freight-carrying ability is concerned were those of 1 1/2-ton and 3-ton sizes. Thus, on a basis of 365 days' work in a year, delivering 28.3 wagon miles, the gasoline trucks delivered an average of 63.67 ton-miles for each day in the year.

Actually, figuring on a basis of twenty days' service in each month, they made 42.5 wagon-miles a day on the average, and consequently 85.62 ton-miles at full capacity.

Now getting down to the cost of gasoline used in furnishing power for these cars, it is shown in the reports of their operation that it cost an average of .0221 per wagon-mile for the fuel used on the three-ton trucks. This would give a ton-mile cost for gasoline of .0074, which was far and away the best showing made in this particular. The wagon-mile cost for gasoline for the three-ton trucks varied between .0199 and .0243, with the average precisely between these two extremes.

Of course all the wagon-mile and ton-mile figures are based upon actual mileages for periods of real service.

With the trucks of one and a half tons' capacity the showing is of a materially higher cost for fuel per ton-mile, although the wagon-mile expense is considerably lower. It was found that it cost from .0147 to .0159 to operate these trucks each mile. The average was .0153. This would give a basis for a ton-mile cost of .01. The average ton-mile cost for gasoline, considering all the trucks used in this illustration, was .0087.

To give some idea of the tremendous number of wagon and ton-miles used in gaining these figures it may be said that 28.3

was the average daily mileage of all the trucks. This would give an exact total mileage per year per truck of 10,329.5 and a four-year total of 41,318, or a grand total of 9,172,596 miles, which is equal to 367 circuits of the earth on its equator. As to the freight-carrying feature, that number of wagon-miles means 20,638,341 ton-miles. At an average cost of .0087 per ton-mile for the gasoline used, the daily cost per wagon would be .553929, and per month \$16.64 and per year \$199.68, and for the four years \$798.72, and for the whole 222 trucks \$177,315.84.

It should be distinctly understood that lubricating oil is not included in these figures.

Summed up they show that the three-ton truck is 24 per cent. more economical in the transportation of one ton of freight for one mile than the truck of half its size, and that the general average ton-mile cost is .0087.

In taking up the subject of the cost of current for the operation of electrical trucks it should be constantly remembered that the figures herewith do not take lubrication into consideration in any way. Naturally the electrics are entitled to some consideration and a material credit in this matter, because while there is no similar item regarded in the figures on gasoline truck operation, if it were regarded it would be very much larger for the gasoline cars than for the electrics. The difference is probably as much as .00218 per ton-mile in favor of the electric cars.

The average mileage of the electric cars is 20 per day for every day in the year, and the service is about 20 days a month, the same proportion as was shown for the gasoline-propelled vehicles. Of the 412 trucks tabulated, 209 were of two-ton capacity and 203 of one-ton size. Due allowance must be made for this apparent discrepancy in service because Sundays and holidays are included, and it should be remembered that many of this big array of electrics have been in daily use for many years, the difference being emphatically marked as against modern gasoline cars.

The current cost per wagon-mile for two-ton trucks ranged between .0474 and .0442, considering both acid-lead and nickel-iron equipment. The average cost per wagon-mile was .0458 and the ton-mile cost of current for this type of wagon proved to be .0229.

As compared with the cost of current for one-ton wagons, this showing is remarkable because it has been found that the one-ton truck is far less economical in this respect. The cost was .0406 on the general average for this size of truck, which is not far from the wagon-mile cost of the wagons twice the size. As the smaller trucks were of one-ton capacity, the wagon-mile cost of gasoline is the same as the ton-mile cost.

Thus the average cost for both sizes of electric trucks was .0317 per ton-mile. The average electric truck delivered 30 ton-miles per day, thus the cost of current per day was .9510, which would make \$347.115 per year and \$1,388.46 for the four years of service, or \$572,045.52 for the whole fleet during the four years.

The average monthly mileage for the electric cars being 600, the yearly mileage would be 7200; the distance traveled in the four years per car would be 28,800, and for the 412 trucks 11,865,600. This represents 17,798,400 ton-miles.

Taking a general view of the cost of operating mechanically-propelled freight vehicles the figures here adduced show the following facts: The data considered shows that gasoline trucks delivered 9,172,596 wagon-miles and 20,638,341 ton-miles in four years at a cost of \$177,315.84, or .0087 per ton-mile for fuel.

The electrics cost over three times as much for current per ton-mile as the gasoline cars required for fuel. The total number of wagon-miles made by all the trucks was 21,038,196, and the ton-miles involved were 38,436,741. The average cost for gasoline and electric current proved to be .0202 per ton-mile, taking all the cars into consideration.

Experience has shown that lubrication is more uncertain in its costs than gasoline and current, but a fairly exhaustive examination of the field tends to show that the average cost of oil and grease for the gasoline car approximates \$70.75 in an average year's running service. This would mean a per ton-mile cost of .00304 for lubrication.

With respect to the electrics it has been found that the average yearly expense for lubrication was only \$9.41, which would indicate a per ton-mile cost of .00086. The difference in favor of the electric car on that basis would be .00218 per ton-mile. This may not be precisely the difference, but it is surely within a small fraction of a mill of the actual figures.

On this kind of a foundation the per ton-mile cost of current and lubrication for all the electrics considered in this article would be .03256, and the ton-mile cost of gasoline and lubrication in the gasoline trucks would be .01174.

As has been noted in previous articles on truck operation, the two-ton electric and the three-ton gasoline types were far more economical in operation than those of smaller size when the figures are reduced to a basis of ton-miles. It is only reasonable to assume that this tendency may be carried out with sizes that are materially larger than those used as the foundation of this article. However, actual figures touching upon this feature of truck operation are not yet available, so the theory cannot be said to be proved in practice.

## New Fire-Fighting Apparatus

### New York City in a Receptive Mood

*The time is now ripe for the general adoption in New York City of automobile fire engines, and it behooves those who can furnish the apparatus to carefully consider what is required of a system that can replace that which is now in use and has been found capable of fulfilling its office in the vicissitudes of actual service. The day of the specialist is here and this must be remembered in constructing both the truck and the pump.*

**R**OME was not built in a day nor was it built through the brilliant achievements of a lone emperor, general or statesman. The united efforts of those who were foremost in their own particular art accomplished the works of law, art and military science which have been handed down to us. For a wagon maker to try to build a pump which will be good enough

to replace the results of years of experimenting and study on the part of those most expert in the science of pump building is as futile as the efforts of our leading pump builders to produce a truck which will supersede the efforts of the specialists in the science of truck building.

A successful fire engine must be as much of a success when it arrives at the point of duty as it was when it was on its way to that spot; and also it must be considered that the best pump on earth is no good to any fire department if it arrives on the scene long past the time when it should have been forcing a flood of water on the fire. The present-day apparatus is not a failure and it is not on such a basis that there is a wild desire to get rid of it and replace it with anything which may present itself; but there is a sane desire to improve it. The automobile has superseded the horse in other lines of work and will no doubt do the same thing in the way of transporting fire ap-



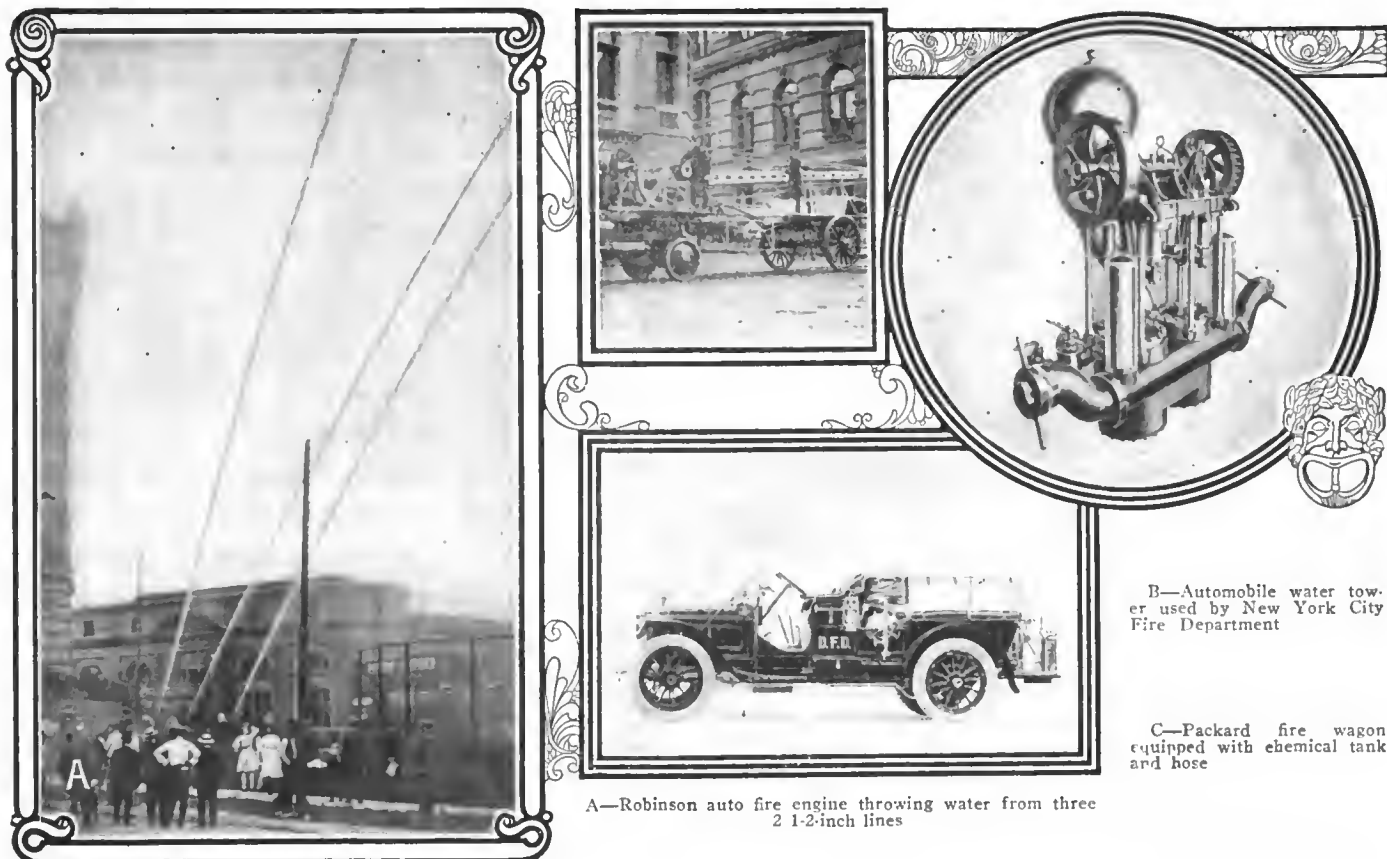

A—Robinson auto fire engine throwing water from three 2 1/2-inch lines

B—Automobile water tower used by New York City Fire Department

C—Packard fire wagon equipped with chemical tank and hose

D—Motor-driven pump on the Knox fire engine

paratus, that is, if the quality of the apparatus is of such a nature as to warrant its use in place of that now employed.

The time is now ripe for such a change. The field is open for the manufacturer who can bring forward a fire engine that will not be the product of either a truck builder or an engine builder, but the combined efforts of the two. To be able to produce such a machine a thorough knowledge of the problem on hand will be necessary, and this knowledge will necessarily consist of an understanding of the policy to pursue to secure a fair trial with a good prospect of the adoption of the machine should it perform in a manner that would justify such adoption and an accurate conception of the requirements in terms of the facilities now on hand. The former will have to be left to the judgment of the manufacturer, while the latter may be partly supplied by a resumé of the situation as it now stands.

### The Hydraulics of Fire-Fighting

The fire-engine question resolves itself from the start into two divisions which are entirely independent of each other. The first part of the matter deals with the transportation of the apparatus, while the second has to do with its operation after it has arrived on the scene of its activities. The high-pressure system obviates the necessity of transporting pumping apparatus by centralizing the plants and feeding water directly to the high-pressure hydrants in the various parts of the city.

The capacity of the fire-fighting pump, as well as any other piece of pumping machinery, can best be considered from a gallon-per-minute standpoint, that is, the ability of the pump to deliver a given quantity of water in a given time. The determining points of the quantity of water delivered will be found to be the pressure at the nozzle and the diameter of the nozzle.

In order to deliver the water at a certain pressure at the nozzle, the pressure at the pumping station, whether it is a fire engine, fire boat or high-pressure pumping station, will be entirely governed by the size and length of the hose line and the bore of the nozzle. To illustrate this fact a practical case may be taken: with a required nozzle pressure of 80 pounds, a two-and-one-half-inch hose line and a length of 400 feet, the pressure

at the engine or high-pressure hydrant must be 150 pounds, using the best grade of rubber-lined hose and a smooth nozzle one inch in diameter. If, however, the bore of the nozzle were changed to one and one-half inches instead of one inch, all the other conditions being kept the same, for an engine pressure of 150 pounds, there would only be a pressure of 36 pounds at the nozzle. A variation in the length of the line would, of course, affect the nozzle pressure in a similar manner.

Besides affecting the engine pressure, the quantity of water thrown in a given time is naturally directly dependent, for a definite nozzle pressure, upon the size of the nozzle. Any calculations for the quantity of water discharged per unit of time may be worked out by formulæ involving the diameter of the nozzle and the pressure at that point. Such a formula will be given later, after a brief consideration of the fire apparatus now in use in Greater New York.

The theoretical range of the stream may be calculated from the gallons per minute of discharge and the size of the nozzle. This, however, is affected to such a degree by wind and other practical considerations, that it is of no real value except, perhaps, as a means of judging the results to be expected.

In the boroughs of Manhattan and the Bronx in New York City the largest fire engine pumps in use have a stroke of 9 inches and a bore of 5.3-4 inches. This pump is of a size known as "extra first" and has a reasonable capacity of about 1,000 gallons per minute. To obtain this capacity through different sets of hose lines and nozzles, with a piston speed of about 400 feet per minute, which is about the usual practice under a steady load, the engine pressure will vary with the number and length of lines used and the size of the nozzles.

### Fire Equipment of Greater New York

In the boroughs of Manhattan and the Bronx there are two of the "extra first" size pumps in use, one with the dimensions given above; the other, while of the same bore, 5.3-4 inches, has a stroke of 8 inches. The reasonable capacity of both these pumps is 1,000 gallons per minute.

Of the remaining 85 steam fire engines in the two boroughs,

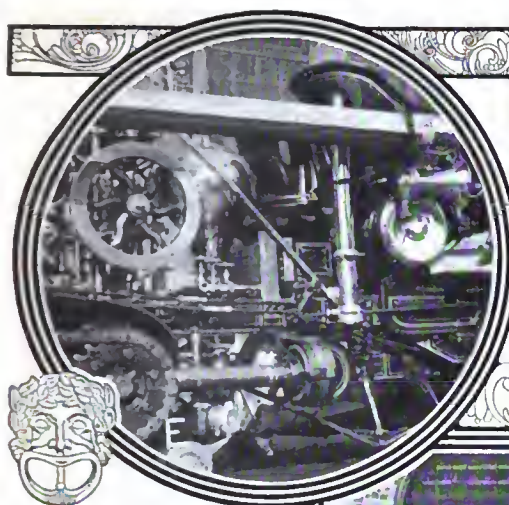

E—View of a motor-driven water pump in chassis

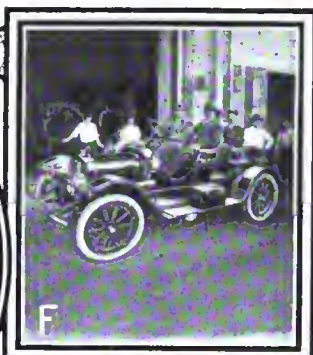

F—White gasoline car used as chief's wagon

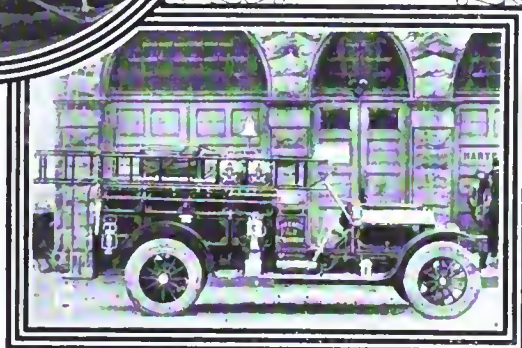

H—Modern type of automobile fire engine sucking water from a stream

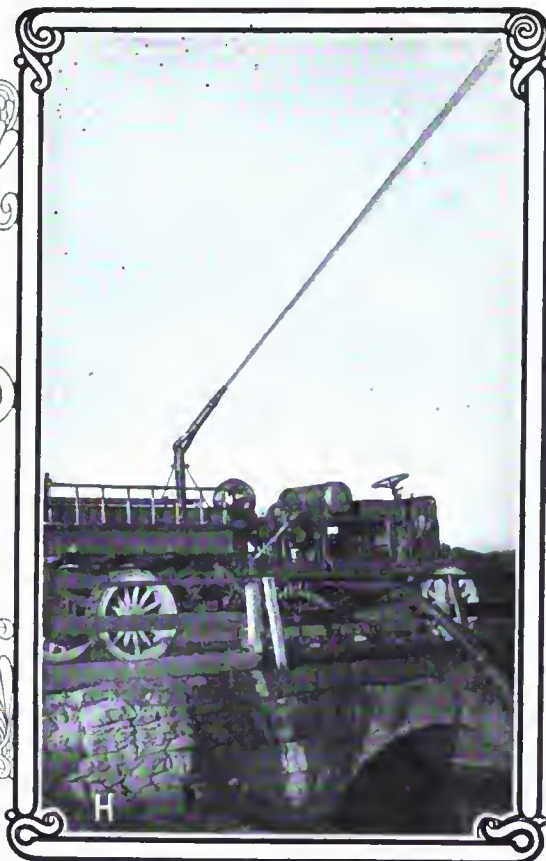

G—Kissel Kar chemical truck

there are 28 of the "first" size, having in the majority of cases a stroke of 8 inches and a bore of 5 3-4 inches. The rest are "second," "third" and "fourth" sizes and range from the size mentioned above, for the "first" size, down to as low as four-inch bore, in the "fourth" size.

In addition to the regular fire engine equipment noted, there are 26 steam engines and seven of the fire fleet. The spare steam engines are distributed about the two boroughs and are kept for emergency purposes.

The boroughs of Brooklyn and Queens are equipped with 81 steam engines and two of the fire fleet. Of the 81 steam engines, 6 are of the "first" size, 15 of the "second" and the remainder of the "third" and "fourth." The stroke and bore of these engines are the same as the stroke and bore of the Manhattan and Bronx engines of corresponding size.

The borough of Richmond has 8 steam fire engines, all of which are of size 4, having a stroke of 6 inches and bore of 5 1-2 inches, with one exception, this pump having a stroke of 7 inches and a bore of 4 inches. The fireboat "Zophan Mills" is included in the Richmond Borough apparatus.

The boroughs of Brooklyn and Queens have 9 spare engines and the borough of Richmond has 3.

### Coping with Water-Front Conflagrations

The fire fleet of the marine division consists of ten fireboats which are equipped with pumps. The "New Yorker" is the largest, her pumps having a total capacity of 12,000 gallons per minute. Next in size are the "James Duane" and "Thomas Willett" each with a capacity of 9,000 gallons. The "Cornelius W. Lawrence," "Abram S. Hewitt" and "George B. McLellan" have a capacity of 7,000 gallons while the "Zophan Mills" and "William S. Strong" have capacities of 6,000 gallons per minute. The two smallest are the "David A. Boody" with 5,000 gallons capacity and the "Seth Low" with 3,500. The total capacity of the fireboat fleet is 68,500 gallons per minute.

To give an idea as to how the water is distributed and the methods in use on the fire boats, it may be well to give a short description of representative boats. The pumps aboard the

newer boats are of the centrifugal type, while the older boats use the reciprocating form of pump. We will take the "New Yorker," however, as a fair example of the distribution of the water supply on the majority of fireboats now in use, and the "Thomas Willett" and "James Duane" as examples of fireboats using the centrifugal type of pumps. The rating of the two latter boats while not so high as that of the "New Yorker" is probably below the maximum available capacity of the pumps.

The Fireboat "New Yorker" has four duplex pumps each with a free outlet capacity of 3,250 gallons per minute. This capacity is reduced of course, when the outlets are connected to the lines; and becomes about 3,000 gallons per minute for each pump. The capacity of the pumps depends directly on the back pressure caused by a small nozzle or a long line. These pumps are of the reciprocating type and are double acting, the water cylinders being 11-inch stream by 10-inch bore.

There are two currents mounted on the vessel, each being surmounted by a Glazer standpipe. The outlet of the Glazer standpipes can be regulated from 1 1-2 inches up. There are eight 3 1-2 inch outlets on each turrent and one 6 inch.

The lines of hose carried on the three reels, which are placed on the deck, consist of two reels, each carrying twenty lengths of 3 1-2 inch hose, and one reel with sixteen lengths of 2 1-2 inch. These lengths are of the standard size, being 50 feet each, making the total hose carried 1,000 feet of 3 1-2 inch and 800 feet of 2 1-2 inch line.

There is a double supply of hose on hand at the slip which is wound upon reels and ready in case of emergency.

The two new boats, the "Thomas Willett" and the "James Duane," of a registered capacity of 9,000 gallons each, are equipped with two turbine pumps which supply two turrents and a water tower. The two turrents are surmounted by Glazer standpipes, as is also the water tower.

The water tower is a skeleton mast built up with four angle irons and lattice work. There is a 6-inch pipe passing up through the water tower, terminating in the standpipe.

The pumps on this boat are, as has been stated, of the turbine type. It has been found by experience that with this type

of pump when the pressure required at a given fire runs above 150 pounds there will be a very large amount of slip. The pumps in a case of this kind should be staged, allowing the water to be forced from one through the other. The capacity when this is done will be reduced to about 60 per cent. of the available.

Where the High-Pressure System Comes In

In case of the water supply failing on shore the fireboats could take the water directly from the river and deliver it to the engines on land. In Brooklyn there are a number of places along the water front where the fireboats can be connected directly to the high-pressure mains in case of the failure of the water supply or of the pumps in the high-pressure pumping stations.

There are two high-pressure pumping stations in Manhattan and three in Brooklyn. One of the two Brooklyn pumping stations is in Coney Island. The locations are as follows: In Manhattan, one at the foot of Oliver street, and the other at the foot of Gansevoort street. In Brooklyn, one at Joralemon street, one on St. Edwards street and the other at Coney Island.

The two stations in Manhattan and the two in Brooklyn proper are equipped with electrically-driven centrifugal pumps, each one having a capacity of 3,000 gallons per minute. The two Manhattan stations have five pumps each, so that the two stations have a total capacity of 30,000 gallons per minute.

The Joralemon street station, Brooklyn, has five of these 3,000 gallon pumps and the St. Edwards street station has three pumps having a total capacity of 9,000 gallons.

The Coney Island station is driven by gas engines which operate three Goulds triple reciprocating pumps having a capacity of 1,500 gallons per minute each. This gives a total of 4,500 gallons per minute for the Coney Island plant.

In certain districts in Manhattan which are protected by the high-pressure stations the engines are not required to respond to the alarms. They are held in reserve. In Brooklyn, however, the signals are answered by the engines as well as by the hose carts and other apparatus.

The Brooklyn high-pressure stations start with a pressure of 75 pounds and the Manhattan with 125 pounds. This is generally sufficient for a small fire. In the case of a high building or a hot fire which cannot be fought at close range more pressure will be required. This is secured by notifying the pumping stations, which can, if necessary, give as high as 300 pounds. The Coney Island station being smaller will give as high as 150 pounds.

The largest high-pressure mains in Brooklyn are 20 inches, the smallest 12 inches. The hydrant pipes are 8 inches. The largest in Manhattan are 24 inches, the smallest 12 inches, and the hydrants 8 inches. In Coney Island the sizes run from 16 inches to 12 inches, with 8-inch hydrants.

The Question of Water Supply

An idea of the total capacity of the fire-fighting water supply in greater New York may be gathered from the total ratings of the three divisions considered: The steam fire engine, the fire fleet and the high-pressure system. The reasonable ratings of the different size fire engines, according to the National Board of Fire Underwriters, is as follows:

Size	Capacity
Extra first .....	1,000 gallons per minute
First .....	900 " " "
Second .....	700 " " "
Third .....	600 " " "
Fourth .....	500 " " "

If the fire engines are figured on this basis the total capacity of the pumping stations of Greater New York is 245,000 gallons per minute:

Manhattan and Bronx.....	65,000 gallons per minute
Brooklyn and Queens .....	49,000 " " "
Richmond .....	4,000 " " "
Fire fleet .....	68,500 " " "
All high-pressure stations.....	58,500 " " "
<b>Total .....</b>	<b>245,000 " " "</b>

This total, of course, is not of practical use and only a small percentage of the whole water supply could be concentrated in one locality. It may serve as a basis of calculation, however, in figuring the available supply of water from a per capita standpoint. The high-pressure mains it must be understood form an entirely independent system, having no connection whatever with the water for domestic service.

Now that we have considered the quantity of water which can be delivered by the three main divisions of the fire-fighting apparatus, that is, the rolling stock, the high-pressure pumping stations and the marine department, perhaps the next thing to take up would be the hydraulic principals involved in delivering the water to the points required and the methods in use by the municipal engineers in calculating the various quantities involved by the problems which present themselves.

Whether from a high-pressure pumping station or reservoir the water is conducted through the streets by water mains of various sizes. The sizes are, of course, governed by the requirements of the particular case. The material of the water mains and pipes in use in New York City is cast iron. The interior of the pipes are coated with a preparation to make them more durable and smoother so as to offer less resistance to the flow of water through them.

The Mathematics of Fire-Fighting

On leaving the pumping station or reservoir the water has a certain head which is utilized in two ways; first to give the fluid a certain velocity and then to overcome the internal resistance of the pipes to the flow of the water. The loss in head due to the frictional resistances of the pipe will vary directly as the length of the pipe line and the condition of the pipe, new pipe offering far less resistance to the flow than old pipe. This fact naturally brings up the old question of the life of cast-iron pipe.

The life of cast-iron pipe is governed by the thoroughness of the coating and the character of the water passing through it. The iron is attacked by the carbonic acid in the water which by a chemical process forms a depression in the pipe in which a little bunch of oxide of iron called commonly a tubercle is built up. Beneath this tubercle a rapid process of corrosion is continually going on. The process of corrosion will start in the most minute imperfection in the pipe coating and for this reason a most rigid system of inspection is necessary before laying the pipe. Well-coated pipe should last fifty years.

The sum of the loss in head due to the frictional resistance in the pipe and the head due to the velocity will equal the total head of the water at the point of entrance to the pipe line.

In figuring the size of pipe required for a particular case the city engineers make use of a table based on two formulæ given by H. Darcy; the first formula for velocities of flow less than

$$0.33 \text{ feet per second, and the second } h = (0.0198920 + \frac{0.00166573}{d})$$

$\frac{1}{V^2}$ , in which H=loss of head due to friction in feet;  $d = d \times 2g$

the internal diameter of the pipe; V=velocity in feet per second; l=length of the pipe in feet;  $2g = 64.324$ ; for velocities of flow equal to or greater than 0.33 feet per second. The method of procedure with Weston's tables, which are based on these formulæ, is as follows, for an example of this type: What size pipe will be required to supply Q gallons of water per 24 hours, under h feet head, the point of delivery being L feet from the point of supply, and the point of delivery having an elevation H feet below the head supplying? The loss of head in passing through the line must not be more than (H-h) in order to have the required head of h feet at the outlet. The table shows what size of pipe will deliver Q gallons with a loss of head equal to (H-h) feet. In case two pipes are necessary the amount Q will have to be divided between two pipes. The number of pipes used is as a rule a matter of discretion with the designer. Examples of other types are worked out in a similar way by the



use of these tables. In New York City the ordinary hydrants may have a pressure anywhere from 75 pounds, which is attained in some parts of Brooklyn, down to a merely sufficient pressure to overcome that of the atmosphere. This will, of course, depend entirely on the locality. In designing the supply for a given vicinity the supply is designed to satisfy the requirements of the highest buildings in that vicinity, the amount required being based on previous experience in the supply of similar districts. This information is kept in tabular form.

The pressure on the high-pressure mains varies, as above mentioned, with the requirements of the case. The mains, hydrants, etc. are designed to take care of the maximum. The pipes of a given internal diameter are made in standard weights, the material used generally having a tensile strength of from 16,000 to 18,000 pounds per square inch. Different classes are being designed to meet different pressures and are used as standard weights for these pressures.

The water delivered from the steam engine pumps is calculated from the displacement. Assuming a double reciprocating pump with a stroke = 1, bore = d, the displacement of the plunger in gallons per revolution would be

$$D = 2 \frac{(d^2 \times 3.1416 \times 2 \times 1)}{4 \times 231}$$

From the quantity obtained from this formula would have to be subtracted the correction for the volume of the pump rod, as this is a large factor. There is a certain per cent. slip which must be deducted from the displacement in calculating the capacity of the pump. This percentage of wasted power, caused by the water getting past the piston, varies with the pressure and the make of the pump. It is large in the case of centrifugal pumps, there are none of these, however, on the New York steam fire engines in the land service.

The flow of the water through the hose is subject to the same hydraulic principles as the flow through the cast-iron pipes. There is a table published by the National Board of Fire Underwriters and supplied to every fire house which gives the gallons per minute discharged from various diameters of nozzles for any nozzle pressure. This table is for the best grade of rubber-lined hose.

A formula worked out from experiments by the New York City Fire Department expresses the gallons per minute for any case:  $Q = \sqrt{p} \times d^2 \times 29.7$ . Where Q = gallons per minute, p = nozzle pressure, d = diameter of the nozzle; 29.7 is the barometric pressure.

The following condensed table, showing the flow of water from a standard 8-inch hydrant under different pressure heads, will show capacities for the various pressures:

Head in Ft.	Ft. per min. vel.	Gals. in min.
.02	1.28	200
.06	1.91	300
.10	2.55	400
.16	3.19	500
.23	3.83	600
.31	4.47	700
.41	5.11	800
.51	5.74	900
.63	6.38	1000
.77	7.02	1100
.91	7.66	1200
1.07	8.30	1300
1.24	8.94	1400
1.43	9.57	1500

### The Ever-Ready Automatic Starter

The production of an automatic device that will do away with the arduous and unpleasant work of cranking the automobile is as welcome as it is useful in a great number of cases. To have to climb more or less gracefully from the driver's seat to the starting crank of a stalled automobile accompanied by the shouts of a traffic policeman and the maledictions of delayed drivers of wagons and cars is a situation that nobody but the man who has been in it appreciates. This state of affairs becomes all the more acute when the unfortunate happens to be a woman trying to overcome a 40-pound compression with a 30-pound pull.

The Ever-Ready Starter is designed to be of use in starting the motor at any time, whether it be stalled or in starting for the run. It can be attached to any automobile or motor boat and is guaranteed to start the same by a simple pressure on a pedal or lever which releases the brakes which hold the mechanism and automatically cranks the motor.

In appearance the starter is very much like a reversed automobile headlight, being about the same size and of polished brass or other finish as may be desired. It is placed on the front of the car at the point where the starting crank is generally placed.

The operation of starting is performed by two powerful springs which are strong enough to spin the motor for about six revolutions against compression at the rate of about 300 revolutions per minute. These springs are wound up by the motor itself during the first twenty-six revolutions made after the engine has been started. When the springs have been fully wound an automatic release comes into play and disengages the winding mechanism from the driving shaft, leaving the starter ready for the next time it may be called upon to start the motor.

It is, of course, understood that the engine must be in condition to start, the same as if it were to be started by hand. In case the starting spring is released without the spark switched on or some other condition of starting left unfulfilled, the starter will have to be wound by hand. A crank is provided for that purpose and a system of reducing gears makes it very easy to wind up to the proper tension. In case the starter is disabled by collision or through some other accident which renders it inoperative, the front cover can be removed and the regular starting crank which was furnished with the car may be used until the needed repairs are made. The device is guaranteed against defective parts for one year.

Owing to the rapidity with which the engine is turned over in starting, the magneto may be used immediately. There is a device by which the starter may be disregarded and the engine turned over slowly for grinding valves or timing the engine.

One of the greatest arguments in favor of a device of this kind is the list of accidents which are directly traceable to the cranking of automobiles by hand. The effect of a "kick-back" cannot be foretold and is often disastrous. Many women are also kept from driving their own machines because they are utterly unable to crank them and cannot in all cases keep a chauffeur.

Agent: "Let me see; you ordered a car from me some time ago, did you not?"

Victim: "Yes! I believe I did. If it is all the same to you I will be willing to change that order to an entreaty."

\* \* \*

"Your Honor," said the attorney, "I propose to show that this prisoner stole ten inner tubes out of the locker of my client's car."

Judge: "So! How do you propose to make a case out of ten inner tubes?"

\* \* \*

Observer: "I see that the widow of old Moneybag married her chauffeur!"

Companion: "Yes! I suppose that she had to do something to keep the money in the family!"

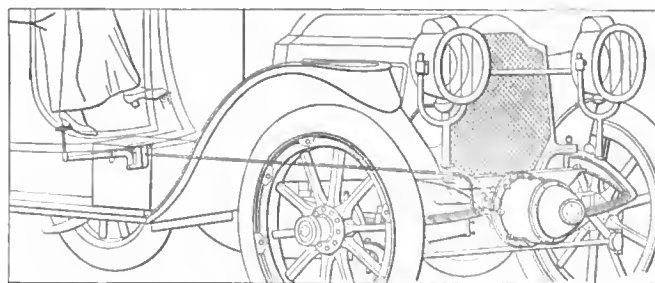

Illustrating the installation of the Ever-Ready Starter on a town car



A—Hair-pin turns are met at frequent intervals on Sicilian roads    B—The author and party after descending into one of the beautiful valleys

## Word-Picture of a Sicilian Tour

### Describing Some Beauty Spots of the Lovely Island

*E. B. Row graphically describes a most enjoyable trip he recently took through the island over which Mount Etna towers in awful grandeur, but which Nature, possibly in recompense for the woes visited upon it in the past, has endowed with a beauty which makes it famous throughout the world.*

**I**N the seventy-odd thousand miles of touring through Europe in an automobile, none of the territory has so appealed to me as the trip just completed around the pretty island of Sicily.

Everywhere there meets the eye a continuous riot of color, with stupendous masses of mountains that overlap each other like the waves of the ocean—mountains everywhere, with lovely valleys in between and no level land, with Etna reaching out into the sky, a dome of dazzling snow towering above all other peaks.

As you skirt the eastern border of the island you run over beautiful roads, narrow but as smooth as the Corniche on the Riviera. You pass through town after town with towers, castles, bluffs, capes and high-topped headlands with rocky promontories and sweeping curves of shore line, all coming into view like a stately procession. To each curve of the coast there is an answering curve of beautiful sea with hundreds of indentations, needle points and forelands of rich and glowing hues, brown, red, purple and violet.

The cities furnish endless quays bordered with snowy palaces in white stone, sickle-shaped harbors, shelving terraces and exquisite vistas of cape and bay. I wish it were possible to picture the foam of the white sea surf beating against lava cliffs with the deep blue tinting of the hills and ever-varying mountain lines that wander heavenward and then sweep gracefully to the sea.

A gem of an island, and with such a history! Gods and demi-gods, heroes and nymphs, nereids, Moors, Sicilians, Greeks and Romans, invaders from every land, in all ages and since all

time, each race leaving the traces of its conquests in stone. In Messina all that was left standing after the earthquake was the cathedral.

The gods have done much for this city, and as long as mountains and sea, sun and sky hold together, it will always be beautiful. Somehow there is an air of innate loveliness one can recognize in a city, as in a woman. Messina has it, while her shipping lends a tinge of cosmopolitanism.

Leaving Messina on the north, you drive over pretty roads, rounding capes and promontories where the blue sea breaks against low rocks, the waves swarming upwards in sheets of curling foam, which mark the outline of delicate bays. Every yard of the highway is historic ground and the home of classic mythology. Every sandy baylet, river, rocky point and headland has its legend.

For over forty miles we drove our Packard in sight of Etna on the north, a wonderful giant, three miles high, the monarch of volcanic life and action. Forests of cork wood, olive, lemon and orange groves encircle its sides for seventy-five miles like a green belt; above this comes the snow line, a mile in width; around its craters all is dead, with lava boulders and streams of blackness flowing from every side.

Taormina is the picturesque city on this end of the island, a pretty spot lying nearly a thousand feet above the sea. From here you visit Etna, whose white flanks sweep down into fertile valleys, dashed here and there by a blackened lava stream. There castles, towns, convents, churches on every height, groves of fruit and vineyards glowing in pretty colors in the transparent atmosphere, while high above the volcano cuts the sky as sharp as steel and steamy clouds from the craters fill up the picture.

At the foot of Etna lies one of the finest harbors in the world, destroyed by lava with ninety thousand of inhabitants, the old city of Catania. A wall of lava forty feet high fills up the port and runs out to sea beyond the entrance of the harbor. Etna is noted for its wine, and vineyards clothe the hillsides on every hand.



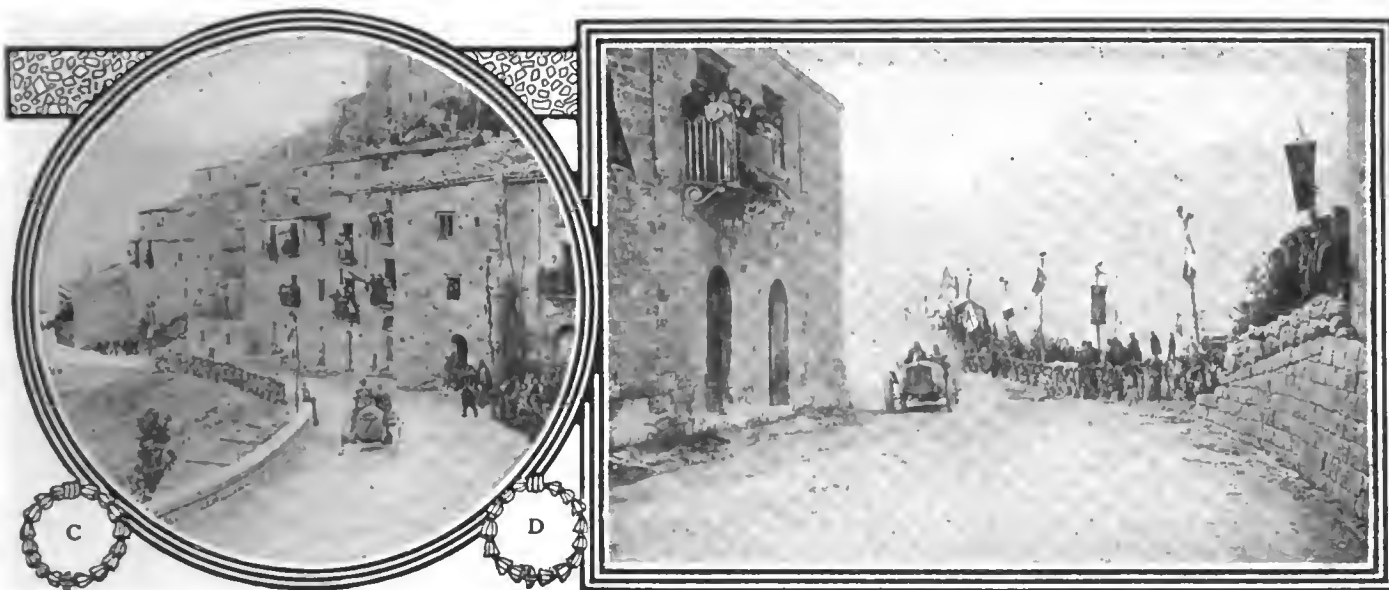

C—The mountain sides form a natural grandstand on race days

D—Interested spectators in the Targa Florio race which is run in Sicily

While in this section no one should fail to visit one of the largest monasteries on the island, where below the church are placed the tombs of the departed. I looked into this burial place where, arrayed in their vestments, all classes of people, dried and set up against the wall or held in niches, or laid to rest in their caskets, are exposed to the view of the visitor. In one velvet-lined trunk was Cardinal Gibonois; next came Count Conrad, son of the philosophic Frederick II; then came Alfonso the Magnificent, King of Naples and Sicily; also many people of Norman line and a royal woman whose name I forget. Here they all rest like passengers in a free berth on a quiet sea. Here are bishops by the score, priests without number, individuals of every station in life sitting or standing for centuries.

The next large city towards the east from Catina is Syracuse, the largest of the Greek ports, and strong in its natural position either by land or sea. From every quarter of the globe enemies

came to this city, taking this place as a landmark for invasion.

The Catholic cathedral here is built over the shrine of Minerva, and some of the Grecian columns mark the side of the church. Of the temple of Diana only little of the marble remains to mark the spot of this once beautiful structure.

All the Sicilians in the country places proved friendly and even cordial. They keep many dogs, which they seem to love as much as their babies. We stopped in mountain cities and were well entertained, the food being very good, but the luxuries in sleeping apartments are apparently not understood.

Sicily is Greek, Doric Greek, as seen in every ruin and temple, some structures still perfect, with no stone missing.

The colors of the sea are marvelous. As you follow the shore line you see blue of every tint, azure running into reds and browns, buff, cream and yellow with sheets of foam that look like lace-work on the pretty shores.

## Short Stories of Current Interest

### Unraveling the Puzzling Situations

*As the art progresses certain apparently unanswerable questions recur, but when the irrelevant matter is eliminated it is not so difficult to get at the facts and arrive at a fitting conclusion.*

IN the discussion of the lubricating problem as it is being presented in THE AUTOMOBILE from time to time, there is an apparent attempt on the part of those who, for one reason or another, cannot well use a lubricator, to show that this device is not essential to success and that simplicity is duly represented when the lubricator is dispensed with, provided only that some lubricating oil is placed in the gasoline tank where it is supposed to be dissolved, and after it flows out of the gasoline tank through the carbureter into the crankcase of the motor it is supposed to re-collect the scattered remnants and to present itself in force at the portals of the bearings, where, after knocking for admission, it is bowed in and permitted to do the lubricating work of which the bearings have enough and to spare. One enthusiast, in de-

crying the idea that an unbroken film of lubricating oil is desired between the journal and the box, went so far as to build a testing equipment on the electrical principle for the purpose of showing that lubricating oil does not present an unbroken film, for, as he states, since lubricating oil is said to be an insulator, should it form an unbroken film the resistance would be so high that an electric current would fail to pass. We do not know whether or not this test shows that the particular lubricating oil used in the experiment is suitable for lubricating purposes in automobile work, but if it is the test as conducted shows that it was not an insulator. If, on the other hand, the test shows that there was no evidence of an unbroken film, it may be taken for granted that the lubricating oil was not of a suitable quality for this class of work.

LIGHTING dynamos are coming into vogue and present practice is somewhat divided between the types of generators that are provided with an electro-magnetic field and the makes

of machines that are equipped with permanent magnets. Since all of these generators have to deliver a direct current for the purpose of charging a storage battery they must be provided with a commutator, and the first difference that a user of an automobile must appreciate is the fact that the average magneto as it is used in ignition work is not equipped with a commutator, but it has a collector ring instead, and the current delivered therefrom is alternating in its characteristic. Since lighting dynamos as they are used in automobile work cannot deliver current for lighting purposes when the engine is shut down, it is the function of the storage battery to supplant the lighting dynamo during the period of engine inactivity, and it remains for the lighting dynamo to charge the storage battery as well as to furnish current for the lights when the engine is running.

One of the serious problems lies in the lack of ability of the average small generator to deliver current at a low speed, and this, in the face of the fact that automobile engines when operating under average conditions run at a relatively low speed, makes it necessary for the user of the car to watch the relation of the generator to the storage battery and to make sure that the battery is not "starved." Some generators are capable of delivering the full charging current at approximately 1,200 revolutions per minute, but it is unfortunate perhaps that quite a number of them deliver but a feeble current at this speed.

When the lighting equipment is new and the storage battery is in good working order it is more than likely that a poor generator will fail to show its weakness, but as the battery tapers off in capacity, and a condition of persistent sulphation arrives, the generator will fail to supply the need and the state of unbalance existing will become only too apparent to the owner of the car. In the purchase of a lighting equipment it is wise to observe the lowest speed at which the generator will furnish the full charging current for the battery, and it is also desirable to observe whether or not there is undue sparking at the brush tips as they contact with the commutator, this being evidence of overwork or a bad state of design of the generator. The practice of looking at the lights to see how bright they are and of judging of the capability of the lighting equipment based upon the illuminating properties of the lamps is bound to lead to a few heartaches on the part of those who are so readily convinced.

WHEN the engineering department of an automobile manufacturing company spends days and nights for months and months in search of the means for silence of the product it is spending money which the purchasers of cars will have to furnish, and it is worth while doing so if the object sought after is gained. But when the automobiles are finished and they are placed before the discriminating eyes of the purchasers it will be too bad if the side-doors of the body are so loosely hung that they will continuously rattle, and it will be a great shame if the mudguards are fastened to the irons by means of flimsy stove bolts. The methods in vogue in many plants are such that the engineers who go in quest of silence have little or nothing to do with the body work, and this plan in the face of a certain type of conceit that finds lodgment in the being of the body-builder makes it easy to see how more than 50 per cent. of all the noise can readily come from the part of the equipment that the engineer has nothing to do with. Fortunately, noise is a condition that the average purchaser can testify to if it exists in a given make of car, and if the builders of automobiles continue to tell purchasers how silently their products perform they may expect that the time will come when these purchasers will take their word for it and govern themselves accordingly. Fortunately, too, it will be quite an easy matter to hang doors in bodies so that they will not rattle, and as for encouraging the makers of stove bolts life is too short.

HABIT gets in the way of every reform that is undertaken, and the man who has acquired all of the refinements of a first-class habit is willing to swear that it is founded upon a true

principle and has right as its mainstay. In the meantime the habit of putting a battery box on the runningboard of an automobile, like the habit of placing the tires in a sling so located as to prevent the driver from getting into the car, is like the habit of placing the headlights on brackets at the front ends of the side bars so exposed that they have to do a double duty, but they serve but poorly as bumpers when the occasion requires. When automobiles were first made the designers thereof were actuated by a certain enthusiasm and they promised so much for their wares that it never occurred to any user that he would have to equip himself with tools for the purpose of making roadside repairs, hence no provision was made in the original designs for the storage of tools.

In the same way not a few tiremakers thought that their "pneumatics" would last for a long time, and the idea of taking along a spare tire was an after-thought dictated by experience on the part of users of automobiles. In the meantime, purchasers acquired the habit of buying cars as they looked standing upon the salesroom floor before the tool box and the spare tires were mounted into position, and the pleasing effect produced really had nothing to do with the appearance of these cars after they were loaded down with junk before they were put into service.

The builders of bodies are beginning to realize the necessity of making provision for the storage of tires in a covered position, and the thought is coming to the front that there should be a compartment for tools. Moreover, there is a splendid opportunity for some bright mind to think out a form of tool compartment that will have a place for everything necessary, and that will keep it in its place without rattling. In the placing of lamps the newer form of flush (electric) lamp is being commented upon favorably, and it is now believed that bodies can be so made that there will be room for everything essential to the success of a tour without detracting from the comfort of the owner of the car and the guests whom he might be pleased to take along.

## May Happen to Anyone

*There are times on a tour of any length when a cool head and a knowledge of what to do under the circumstances are of invaluable assistance to the driver, be he professional or amateur. A hint which is the proof of experience may be of use.*

AN affair of frequent occurrence in general driving is the ascent and descent of steep and slippery hills. Obviously, in descending, the brakes must be used in order to keep the car under control, but the autoist often finds that their application causes the rear of the car to swing around, particularly if one hub-brake has a better grip than the other. With smooth tires, that is, tires without studded treads or unequipped with chains, the situation is hazardous despite anything the autoist may do, but in all cases such hills should be approached at a walking pace and the car prevented from increasing its speed by judicious use of the brakes the whole way down. Equally awkward is the ascent of a hill thickly coated with mud. In such case, once the wheels commence slipping the car may tend to spin in a circle and to slip backwards while so doing to the bottom of the hill. If the hill is extraordinarily steep and greasy, several circles may be described if the car is small or has excessive clearance, and the autoist will not have the slightest control over the car during the evolutions. In climbing ordinary hills that are greasy, a moderate speed should be maintained from bottom to top, avoiding any sudden acceleration of the road wheels, and momentarily easing off the drive to enable them to regain their hold at the first signs of excessive spinning. The ability to drive at a constant speed is invaluable to the autoist in cases like this. Where ascents or descents are hazardous, rope wound around the tire and felloe is often an invaluable aid.

# When Judgment Whispers Don't

## A Series of Abbreviated Injunctions

*It is suggested that common sense and uncommon dollars are congenial to each other, and through force of habit occupy well-cushioned seats in the same chariot.*

- DON'T look for a rich farmer on a bad road.
- DON'T look for a bad road in front of a rich man's residence.
- DON'T object to the improvement of roads just because you are not the possessor of an automobile.
- DON'T forget that your income may be traced to automobile activity.
- DON'T sit in the Senate if you are so stupid that you bark at the automobile fraternity.
- DON'T undertake the futile task of proving that you are an intellectual if you legislate against the third industry in the world.
- DON'T fail to resign your position in the Legislature if you examine yourself on a dark night and find that you are an incompetent.
- DON'T delay action just because you fail to see the point—the public will understand it if you don't.
- DON'T advocate that the residents of the penitentiary make clothes for you to wear—they can be placed to better advantage fixing the State roads.
- DON'T permit States' prisoners to compete with honest workmen in the industries—road-building is a much more healthy occupation for prisoners.
- DON'T fail to request your representative in the Legislature to make some provision for the maintenance of roads.
- DON'T overlook the fact that road-building represents a waste of money if no provision is made for the maintenance problem that follows.
- DON'T eschew political activity on the ground that you are too immaculate to rub elbows with the type of politician who would rather see you vote from a cemetery than elsewhere.
- DON'T let political grafters run your business for you—do you think so much of them that you would place them in your own office?
- DON'T fail to appreciate the fact that every politician is working for you whether you like it or not.
- DON'T forget that some politicians give two licks for themselves for every lick they give for you.
- DON'T take your automobile over a bad stretch of road without making a complaint in writing to the president of your club.
- DON'T belong to a club without advocating that its members go in for good roads.
- DON'T try to usurp the functions of the officials of the club to which you owe your allegiance.
- DON'T forget to nudge the officials of your club if they go to sleep.
- DON'T fail to appreciate the difference between co-operation and the action of a disorderly minority.
- DON'T be discouraged if you fail to get action the first time you bring an important matter to the attention of the club officials.
- DON'T act with impatience in the face of an important emergency—success follows in the wake of calm and deliberate presentations of good arguments.
- DON'T try to have your own way unless you can at least prove to yourself that it is a good way.

- DON'T expect others to approve of your way if you cannot approve of it on your own account.
- DON'T run around in an automobile without knowing anything about speed laws.
- DON'T forget that law is supposed to be based upon common sense as well as upon precedent.
- DON'T fail to display a fair measure of common sense if you are short of legal lore.
- DON'T try to become a curb-stone lawyer if a policeman makes a few pointed inquiries about the speed at which you were driving your car.
- DON'T try to convince a policeman that you were going backwards if your car was picking up the road in the opposite direction.
- DON'T object to reasonable police regulations, even if they do differ from each other in the towns that you pass through in a day.
- DON'T forget that the citizens of each township have the happy faculty of understanding their own local situation in a manner satisfactory to them.
- DON'T forget the old adage "When in Rome do as the Romans do."
- DON'T toil with ignorance—learn something about the mechanisms in your automobile.
- DON'T act like a star of the first magnitude when you meet a farmer on the roadway—he may have a little star factory of his own.
- DON'T mistake egotism for power; the egotist stands in front of a mirror; the man of power has a strong stride, but he never gets out of breath.
- DON'T fear your self-appointed enemies; they are more scared of you than you can be of them.
- DON'T be eddied out of the main current—your franchise is good; use it.

## Vanadium in Steel

*Describing the process to be followed in testing a sample of steel in order to ascertain if vanadium is present therein, and in what quantity. By this test it is said to be quite possible to detect as small a vanadium content as 0.01 per cent.*

A RAPID chemical method for ascertaining the presence of vanadium in steel is based on the fact that a brownish-red coloration is displayed when vanadium salts are acted upon by peroxide of hydrogen. The method of making the test is as follows: Dissolve 0.25 gram of the steel to be examined in 4 cubic centimeters of nitric acid of density 1.20; heat; add about 0.3 gram of persulphate of ammonia. There follows a discharge of gas. Heating is continued until this discharge ceases. Then the solution is cooled. There is added 3 to 4 cubic centimeters of phosphoric acid of density 1.30. The yellow coloration due to the iron ceases and the liquid remains only faintly rose colored. Shake. By means of a pipette 3 to 4 cubic centimeters of peroxide is poured into the test tube slowly so only thin films of the two liquids are mixed at the point of contact. In the zone of contact there is now formed, if vanadium is present, a brownish-red ring. As little as 0.01 per cent. of vanadium can be detected by this method. By comparison with samples of steel whose vanadium content is known, and which are treated in the same manner, the vanadium content can be approximated.

# Facilities for the Hardening Room

## Quenching Baths and Their Accessories

*E. F. Lake discusses quenching baths for the hardening of steel and makes comparisons for the benefit of the man who must obtain results, giving quenching temperatures and simple rules for the governing of the process, illustrating the points that are uppermost in the story.*

A GREAT deal of attention should be paid to the baths in which to quench steels when hardening. This is of as much importance as the degrees of temperature to which steel is raised or the constitutional changes that take place. The rate of cooling is not instantaneous and consequently is not swift enough to secure perfection. Thus the intermolecular transformation will be more or less incomplete, according to the rate of cooling; the better the bath the better the results that are obtained.

Many different materials are used for quenching baths, and the more common are enumerated below according to their intensity on 0.85 per cent. carbon steel: Mercury; water with sulphuric acid added; nitrate of potassium; sal ammoniac; common salt; carbonate of lime; carbonate of magnesia; pure water; water containing soap, sugar, dextrine, or alcohol; sweet milk; various oils; beef suet; tallow and wax.

As the conductivity and viscosity of these baths varies greatly with their temperature they do not act under all conditions with the same relative intensity. The curves of intensity are therefore very irregular and cross each other frequently. With the exception of the oils and some of the greases the quenching effect increases as the temperature of the bath lowers. Water at 60 degrees will make steel harder than water at 160 degrees. Sperm and linseed oils, however, at all temperatures between 32 and 250 degrees F. act about the same as distilled water at 160 degrees F.

The influence of the bath depends upon its nature, its temperature and its volume, or, in other words, on its specific heat, conductivity, volatility and viscosity.

The specific heat of the bath is an important factor, and yet but little attention is paid thereto. The more rapidly we cool a high carbon steel from 1650 to 200 degrees F. the more effective will be the hardening process, these being the temperatures at which the transformation corresponding to the hardening process begins and ends.

When a bath is constantly used the first piece quenched will be harder than the tenth or twentieth, owing to the rise in temperature of the bath. As soon as the heated metal is plunged into the bath the liquid begins to heat. The number of calories necessary to raise the liquid's temperature a certain number of degrees will be the greater the higher its specific heat. A bath is the more active in proportion as its specific heat becomes higher. The less rapidly the equilibrium is established between the hardening bath and the metal quenched in it the more active will be the bath.

Mercury has a much lower specific heat than water, and quenched steels are cooled nearly three times as rapidly in water as they are in mercury. The hardening effect is therefore much lower than that of water, but surface cracks and fissures are not nearly as liable to occur.

As steel is plunged into a liquid that volatilizes easily at the high hardening temperature a space is formed around the metal that is filled with vapor, and this retards the further cooling action of the liquid. To overcome this it is necessary to either keep the piece moving around in the water or keep the bath in motion so that these vapors will be thrown off and fresh liquid be continually brought into contact with the metal. This continual motion effects the exchange of heat between the piece being hardened and the bath, and the greater the conductivity of the bath the more quickly the metal cools. The viscosity of the

bath has an influence on the phenomenon of convection, which is the principal means of the exchange of heat; the higher the viscosity the less its hardening effect.

The mass of the bath can be made large, so that no great rise in temperature occurs when continually cooling steel pieces. If the rise in temperature of the bath can be properly regulated it can be made small and this rise in temperature be made useful when hardening parts that should remain fairly soft. It would thus save the time used in reheating and tempering the piece later and largely overcome the liability of its cracking or checking when quenched.

Another way of arriving at the same results would be to use a double quenching bath. In this process lead or salt is often used and maintained at a certain temperature. The piece is quenched in these until it reaches their temperature and is then removed and quenched in a cold bath or cooled in the air.

The baths which give the best results are those in which the temperature is always kept even. If considerable time elapses

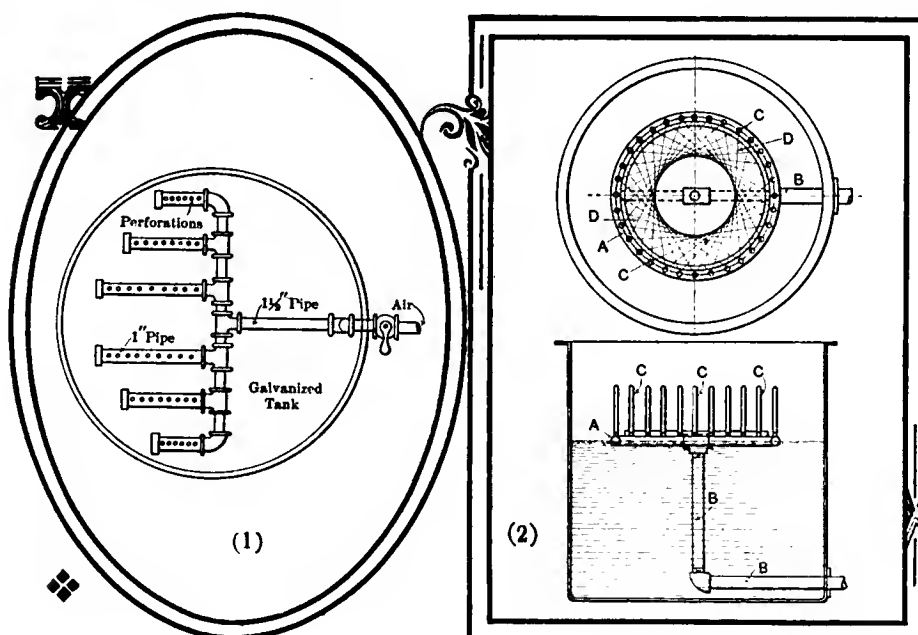

Fig. 1—Showing the method of piping in the bottom of a quenching tank for the distribution of the air that is proposed for the agitation of the bath

Fig. 2—A spraying type of quenching bath for use in the hardening of steel

between the quenching of different pieces the bath will retain an atmospheric temperature from its own natural radiation. When a continuous quenching of pieces is necessary some mechanical means must be provided. The bath must either be very large, so it will keep cool from natural radiation, or the liquid must be kept flowing in and out of a small bath to keep it cool. Better results can be obtained from the small bath cooled by mechanical means, as its temperature can more easily be regulated and kept constant.

One method that gives good results on certain kinds of work is the spray that is thrown from a circular gas pipe with perforated upright pieces, as shown in Fig. 2. In this A is a circular gas pipe into which are screwed perforated upright pipes CC and intake pipe B. Water coming through perforated pipes CC forms a spray on lines DD.

Another method is to place pipes in the bottom of the bath, as shown in Fig. 1. The liquid is pumped through these and allowed to overflow at the top.

Another method is to surround the tank with a perforated sheet and pump the liquid through these perforations. Some baths of this nature have been fitted up with a conveyor that carries the pieces through the bath and drops them into receptacles placed at the other end.

## The Search for Silence

*With the disappearance of noise from the motor, those other members of the chassis whose noisy performance was formerly drowned in the motor's din, have become prominent disturbers of the motorist's equanimity, which presages, among other possibilities, the more general adoption of the worm drive and a substitute for the live rear axle with its loose joints.*

NOISE as it is being taken out of the motor uncovers the noise that has always resided in the chassis, and the coming of the silent types of motors has brought designing engineers to a realization of the fact that what they call silent performance in the chassis amounted to a positive din. In the meantime, purchasers of automobiles have been preached to about silent performance until some of them have been persuaded to believe that their noisy machines were silent and that noiselessness is the first requisite in the operation of an automobile. Under the acute conditions of to-day it costs more money to get noise out of an automobile than it does to build the car. Where this search for silence will end it is difficult to say, but the fact remains that quite a number of automobiles are unduly noisy because of the use of stove bolts in the holding of the mudguards and in the employment of other flimsy pretexts that have no fitting place in the makeup of an automobile. In the meantime, it is pointed out that some of the most approved practices of the present day are at variance with the necessities from the silence point of view, as, for illustration, a full-floating live rear axle has a number of loose joints in its makeup, nor would it be a full-floating live rear axle were these loose joints done away with. How to drive through a dog and maintain a condition of silence is one of the problems that engineers have to cope with, and if the search for silence continues, becoming more acute than it is to-day, the live rear axle and the dog drive will certainly have to make way for the type of fits that do not depend upon lost motion. The best argument in favor of the worm drive is that of silence, and the probabilities are that the search for noiseless performance will bring the worm drive into general use to the entire elim-

ination of the bevel drive. It is not claimed that the efficiency of a well-made worm drive is quite up to 95 per cent., and few indeed are the engineers who will make so brave as to claim that a bevel drive has an efficiency of more than 95 per cent. It was not so long ago when one automobile-building concern claimed that in the search for silent performance it had to discard 55 per cent. of all the bevel gears that were turned out in its plant, and the wildest flight of the imagination is insufficient to make one believe that any such poor luck would attend the building of worm drives.

## Labor-Saving Device in the Testing Shop

In days of large production such as the present every conceivable means is devised in the shops to save the men unnecessary labor. It was no common occurrence a few years ago to see motors being carried by two or three men from one part of the shop to the other, but such laborious methods no longer exist. Either a traveling crane is used or the motor is placed on a truck which runs on rails, and by the aid of cranks it can be transferred from one shop to the other. That is all very simple and the next operation after the fitting cannot be regarded as hard work. This consists of "running the motor in" by means of a belt, using the flywheel as a pulley off another pulley of suitable dimensions attached to the ordinary shafting. This operation may last for several hours, according to the motor; but when it arrives in the running shed and is run under its own power for several hours and the different parts adjusted, the tester is usually given the task of starting the motor in the usual manner, i. e., with a starting crank. To do this once or twice is no hardship, but when he has six to one dozen motors to test and they have to be stopped, say, every half-hour or oftener, the amount of manual labor that the tester has to perform is infinitely greater than the testing operations themselves. Besides, he soon becomes tired, and a tired man cannot be expected to furnish the same good work as a man who is fresh. In order to overcome this a means was devised in the Everitt plant in Detroit, whereby all manual labor in starting was done away with. With an electric motor on wheels, as shown in the illustration and a pulley attached to the main shaft, a belt can be slipped over the flywheel of the motor to be started. The electric motor is then started, the current being furnished from main leads and a length of flexible cable can be fitted into one of the several plugs in the wall. The tester then gently pushes the truck forward along the rails and as the tension of the belt increases the motor is started. It is an easy matter to throw the belt off the flywheel. The illustration shows only three motors, but in reality there is often room for twenty at a time along the line.

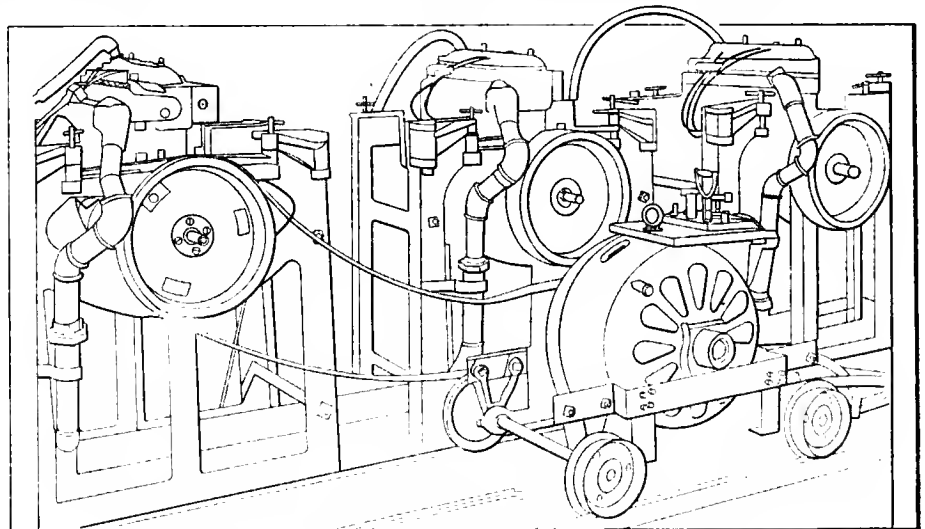

Fig. 1—Method of starting motors in the Everitt testing shop by means of an electric motor and a belt



# It Stands to Reason—

## (When Common Sense Sits Alongside of the Driver)

THAT tires are made of that strange substance called rubber in combination with a frail fabric called "cotton" no matter how carefully they are made, and long life is only to be experienced if the automobile is driven at a slow rate of speed when the roads are bad.

THAT long life of the tires will not fall to the happy lot of the automobilist if high speed is indulged in when the mercury in the thermometer soars to high levels.

THAT over-inflation is too much feared by the average owner of an automobile, and it is scarcely to be supposed that a puny tire pump will be guilty of any such crime in any event.

THAT under-inflation is the common disorder that besets tires at every hand.

THAT a tire-gauge is the only sure tell-tale available to the man who desires to operate his tires at a predetermined pressure.

THAT even a tire gauge accompanied by a poor pump in the hands of a lazy chauffeur will fall short of its intended purpose.

THAT the lazy man may not be a chauffeur after all.

THAT any amount of pressure will be of small avail if the tires are too small for the work that is assigned to them to do.

THAT the purchaser of an automobile should decline to take a demonstration from the maker if over-sized tires are used on the demonstrating car, provided they are not used on the car that the purchaser is to get.

THAT tires indicate their lack of proper size if they cannot be inflated to roundness under the load that they have to operate with.

THAT tires will creep in the rims if they are not properly fastened and no end of trouble will result.

THAT a tire lubricant, such as talcum, should be used between the tube and the case to prevent chafing of the walls of the tube.

THAT tires will be eaten up by mildew if the rubber coat is punctured and water is permitted to get at the cotton of the fabric.

THAT rubber is used as a seal to prevent mildew from getting at the cotton of the fabric as well as for other purposes.

THAT the average automobilist fails to appreciate the enormity of the appetite of a few million mildew "bugs."

THAT rubber, in addition to sealing up the fabric, shows a certain strength besides binding the layers of the fabric into intimate relation to each other.

THAT the tread of the tire, since it must serve as the buffer between the roadbed and the carcass, is made of a toughened compound that will only adhere to the carcass if it is carefully put on.

THAT the carcass and the tread should be kept welded to each other all of the time.

THAT tires will give out more rapidly when the weather is warm, due to the fact that rubber loses much of its strength at high temperatures.

THAT driving the automobile at a low rate of speed is the proper thing to do when the weather is warm as well as when the roads are bad.

THAT putting on the brakes too suddenly will produce skidding and a high rate of tire depreciation.

THAT good driving cannot be measured by the number of times the brakes are suddenly applied.

THAT going around a corner on two wheels may be picturesque, but the tire bill resulting can scarcely be viewed with equanimity.

THAT an automobile will make the greatest possible distance in a given time if it is driven at a uniform rate of speed.

THAT storing an automobile in a garage where the floor is coated with grease adds to the cost of storage to the extent of at least four tire cases per month.

THAT standing an automobile out in the glare of a summer's sun is the best way to help the tire maker broach a watermelon.

THAT high-speed work when the road is wet and jagged rocks abound is another way to keep the tire maker out of the poorhouse.

THAT the tire maker is already too busy, and it is unnecessary to burden him with the making of extra tires for no better purpose than to furnish replacements to the type of man who would not know common sense if he saw it coming down the road.

## Long-Distance Touring in Australia

*Recounting the difficulties experienced by a party of automobile tourists in Australia, where it is sometimes necessary to keep a sharp lookout to avoid missing the road. Sandy wastes abound in some sections, and if the travelers lose their way, it means a long delay, and possibly worse.*

THE ride just concluded by a party of prominent Australian automobilists from Adelaide to Sydney was full of interest. They passed over many pleasant stretches of Nature's highways, many of them unimproved. One of the interesting runs covered 92 miles, between Kinkston and Meningie, which occupied a day. But at all times one needs to look well ahead, for to lose the road means a series of difficulties and maybe mishaps. Take, for example, the Coorong, a cheerless waste, where mighty sand drifts choke the roadway. Some of these drifts rise to a height of 87 feet, while heaps of from 7 to 10 feet high are common barriers. When practically lost amid these sand drifts, the automobilist finds it very difficult to make a long detour. He is obliged to watch for the proper divergence by means of which he can shoot his motor car through into the region of roads again. Sometimes it happens that the automobilist misses the longed-for deviation path, owing to scant evidence of travel. At such periods he brings his car to a standstill, hard against a forbidding ridge of sand. The result is that when the wind blows the automobilist "grits his teeth" in good earnest. Recently a party of motorists lost their way while casting about in the sand and they had quite given over to despair when a horseman hove into sight who piloted the car along a crooked route, thus enabling the party to reach Meningie as the night closed in.

LONDON, ONTARIO, has adopted the motor car method of sprinkling the streets. The City Fathers have put two automobile sprinklers into commission, thereby saving \$14,000 annually, as compared with the horse-drawn watering cart service. It is proposed to install two more of these sprinklers, doing away with horse-drawn vehicles for this work altogether.

# How to Improve Harsh Suspensions

## Hints on How to Secure an Easy-Riding Car

*The question of the suspension of cars is dealt with in a recent issue of "La Vie Automobile," by André Guetet. The action of the springs is considered in some detail, and the necessity of paying attention to the centering of the superimposed masses is also explained.*

**I**S it possible to ascertain if a car is well suspended by a simple inspection of the springs? This is a question that drivers often ask themselves. First of all, what is a well-suspended car?—a question that is much more difficult to answer than would be imagined. One often feels, in comparing the riding qualities of one car with those of another, the difference in the comfort; but there lies a set of variable quantities even in the same car, according to the road surface, the weight carried, the state of lubrication of the springs and also the question of shock absorbers, and so on.

Quite independent of the want of comfort of a badly suspended car, it is safe to say that it is far from economical. From two points of view such a car is a burden. First, on account of the continual bumping of the driving wheels on the ground and the harsh recoil on the road surface, each blow thus struck forms as it were a rasp of great power that causes the tire to part company with the precious rubber casing. This inconvenience is particularly noticeable on certain shaft-driven cars. Secondly, one thing must be borne in mind, viz.: every shock and every resulting vibration takes away power from the motor, which will entail an increased and unnecessary consumption of gasoline. It has been noticed in some cars, to which shock absorbers of good construction properly regulated have been added, that by simply removing one leaf of the spring an increase in fuel consumption has resulted, even as much as 1/3 to 1-2 of a gallon in 100 miles, according to the power of the motor, and without touching the carbureter regulation at all.

The question of good suspension is a vital one in the conservation of a car. The shocks and vibrations quickly cause the homogeneity of the different points that are attached to one another to become broken. There is not a car made in which there is not some vibration, and this must be eliminated as far as possible. Besides, it is a well-known principle in mechanics that a noisy machine cannot be economical. It remains, therefore, to consider the different methods that can be used in order to better the suspension of a given car.

At the outset there is a question of the why and the wherefore. Why is it that manufacturers do not make all cars with soft springs? There are two reasons for this—one being that they cannot know beforehand if the car is to be fitted with a light touring body or a limousine, and they choose, and rightly so, a happy medium by fitting semi-soft springs. In most cases when a chassis is tried out on the road on what is called the road test it is fitted with two spider seats and a box which should be fitted with weights, but these are seldom used on account of the tiresome operation entailed in the lifting. It is evident, therefore, that the chassis is tested for mechanical efficiency only, the question of suspension not being considered in the trial. The second reason is that constructors, relying on the excellence of certain shock absorbers which are to be found on the market, and which can be regulated according to the weight of the car, leave this regulation of the springs to their clients. It may be noted that several manufacturers of high-grade cars deliver their chassis already fitted with shock absorbers, and it only remains to adjust

them. This is, perhaps, one of the happiest solutions of the suspension problem.

How can one find out *a priori* whether a suspension is soft or hard? It has been shown that the springs should be—

1, sufficiently flexible to absorb the shocks due to the inequalities of the road;

2, sufficiently resisting and elastic so as not to take permanent deformations under a heavy weight or from a very violent shock.

What is known as the flexibility of the spring is the quotient of the flexure divided by the weight of charge, and it is calculated in millimeters per hundred kilograms. There is another point to be considered, and that is that in cases of great oscillation the chassis shall not touch the axle.

The flexibility of a spring depends upon its dimensions; it is advantageous to use springs sufficiently long to withstand the large amount of deformation and sufficiently broad to give the car a trim so that it will withstand the transverse strains. In order to take care of this latter it is necessary to always place the rear springs, which carry the most weight, outside of the chassis frame and as far apart from one another as possible. The front springs, which only have to support the weight of the motor and to resist the oblique strains when the wheels strike obstacles, are always under the chassis, which allows of a larger lock for the steering wheels. The length of the spring ranges between 800 and 1400 millimeters (31 1-2 and 55 1-8 inches), measured between the axes of the spring bolts, and the thickness varies from 4 to 12 millimeters (.1517 to .4724 inches). As a general rule the longer the springs are and the wider and thicker the more flexible they will be. This is only relative to the different leaves that form the whole spring.

The entire spring has to resist flexure and torsion, and it is impossible to construct the spring of a single leaf for the double reason that the more leaves there are in the spring's construction the more flexible it becomes; and on the other hand it is more costly. The springs are generally of decreasing length, starting with the master leaf, which is directly connected to the chassis by means of shackles or scroll irons, as shown in Fig. 1. The leaves are held together by a center bolt attached to the perch of the axle by means of clips with a block interposed. As at flexure moments the give of each of the elementary springs is diminished (certain springs are quite flat when not acted upon and work in counter), it follows that the extremities of each of the leaves are displaced and each slides on the one next to it. They are guided in this relative movement by detention pins for the master leaf and by projections in the notches of the other leaves. One thing, therefore, stands out quite clear—the relative movement of the leaves must be facilitated by lubrication. It is most important that this point should receive the amount of attention it requires. Vaseline should be used and spread on the leaves with a piece of cloth while the spring is disassembled. The chassis can be lifted with a jack if it is not found convenient to take the springs apart; this has the effect of causing the leaves to gape in the manner shown in Fig. 2, and with a long-spout can oil may be introduced between the leaves; but the oil should be fairly thick. It has been suggested that springs should be protected from the dust, mud and especially the water used when washing the car, by means of pliable leather covers or some other waterproof material. It would be possible by that means to always maintain the suspension in the same condition and as supple as originally. On quite a number of cars one can see small rusty blotches, which show that the springs are never lubricated.

One means of keeping the leaves in perfect condition consists of introducing between each leaf a very thin layer of special bronze; by that means an automatic lubrication is obtained which is excellent from the point of view of suppleness.

The different leaves have radii of curvature which cross from the smallest to the master leaf; that is to say, the short leaves are more circular than the larger ones, so that the contact between the different components shall be equal over their entire length. Under these conditions it is easy to see that the friction existing between the leaves is opposed to the brutal expansion of the spring and the dual purpose is served as follows: The lubrication of the leaves renders their sliding movement easy under the compression, which permits the spring to absorb as completely as possible the sudden force of the shock during the expansion; the movement is, besides, lessened, which absorbs in a certain degree the oscillations.

The period of oscillation of a spring is quite appreciable; this period may be equal to the frequency with which the shocks are received, or it may be a multiple. In this latter case the amplitude of oscillation may grow indefinitely and cause the breakage of the spring. This may happen on very stony roads, and the only thing to do under such circumstances is to slow down.

Springs may be classified into several categories, as shown in Fig. 3:

1. Half elliptic, that can carry a shackle at either of the two extremities or at both; very much used.
2. Elliptic, consisting of top, half elliptic; bottom, half elliptic, united at both extremities by bolts; not used in present-day construction.
3. Three-quarter scroll elliptic, consisting of upper, quarter scroll; bottom, half elliptic. They are hinge springs when the top half is as shown in A-3 in Fig. 3 and shackle springs when it is curved and attached from underneath to the lower spring, as shown in B-3, Fig. 3. The first type is found fairly often, and the second is found frequently on good cars.
4. C springs, sometimes found on cars de luxe, are very curved—a construction that costs money without adding much to the suppleness.

5. The half springs that are found on some of the cheaper grades of cars have the inconvenience of imposing a large amount of work on the chassis supports.

These considerations, together with the length of the leaves, their number and the width and thickness thereof, permit one to obtain an idea of the suspension of a car for a predetermined weight.

It is a wise plan to mount the axes of the spring shackles with a cardan to prevent the torsion effect being transmitted to the spring. This is found in but one make of car, as far as it has been possible to discover, and that is the Daimler. There are a number of cars of modern manufacture that are not fitted with greasers on the spring bolts with the ordinary type of shackle; these rust up and bind, making a horrible noise and wearing out very quickly and occasioning sometimes a sudden rupture. This is one point of the suspension that should receive attention, and

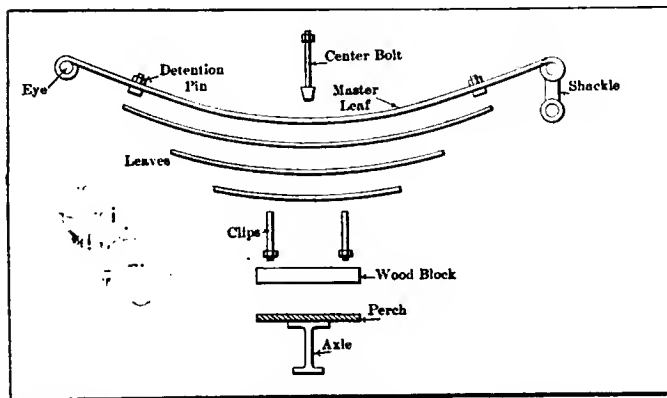

Fig. 1—Different component parts of a semi-elliptic spring and the method of attachment

in purchasing a modern car one should insist on such grease cups being fitted to the shackle bolts as well as the front spring bolt.

The suspension can be improved considerably by using the properties that reside in spiral springs, as these have a period of vibration much shorter than springs of the leaf type. The amount of tension of the spring can be adjusted when it is attached to the shackles in such a manner that it dampens very quickly the vibrations of the suspension. As a whole the good suspension of a car is realized by the use of long and broad springs, with a small amount of flexure and made of good steel, with a preference for that with a percentage of silicon or tungsten. The softest suspension will be found in cars with three-quarter elliptic springs in front (very seldom used) or half elliptic springs; and for the rear using a three-spring suspension known as three-point suspension or by half scroll elliptic springs.

Under normal running conditions the small vibrations that are not greater than 20 millimeters are absorbed by the tires, but for

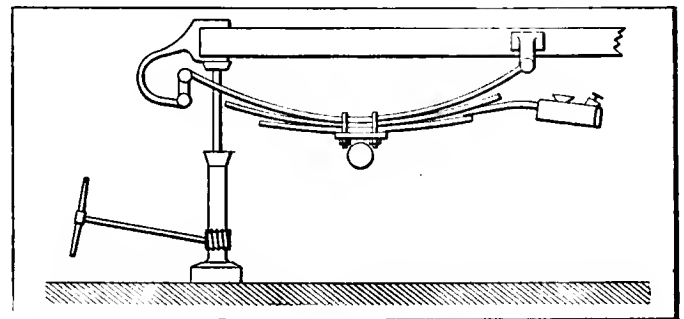

Fig. 2—Method of lifting the chassis by means of a jack so that the leaves will separate and allow oil to be inserted

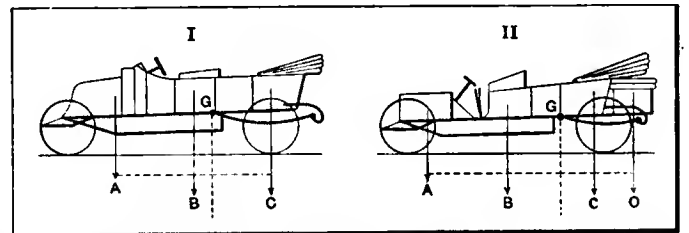

Fig. 4—Showing the difference between the centration of the masses on two different types of cars. It will be noticed that the masses A and D in II are far away from the general center of gravity G in comparison to car I

larger vibrations the spring deflects and by reaction the chassis is forced upwards. In consequence of the inertia of the total mass in movement the bending of the spring becomes greater than it would otherwise be in a state of equilibrium, the recoil and the series of oscillations being the cause of all the discomfort in the car. These oscillations are more dangerous than would be imagined, causing as they do a lifting of the driving wheels and consequently a diminution of adherence; the wheels slide and when contacting with the road surface the tires are subjected to a rasping action each time, causing rapid wear.

In shaft-driven cars the non-suspended mass comprised of the differential and casing together with the wheels and brake drums is very important because the weight may be as high as 180 kilogrammes (about 400 pounds), but in the case of chain-driven cars this weight is not more than from 120 to 150 kilogrammes (264 to 330 pounds). Here is one cause of the wear of tires on shaft-driven cars in excess of chain-driven cars, independent of the road-holding properties, which may be bad, according to the suspension. This may be improved by using springs that have been carefully studied and fitted with shock absorbers properly adjusted. Further, the shaft-drive is drawing recruits every year more and more owing to the silence, its more mechanical aspect, its cleanliness and efficiency.

The duty of shock absorbers (Fig. 5) is, by means of additional friction, to exterminate the oscillations of the springs that

have taken effect under the conditions above stated. These can be classified into four heads, as follows:

1. Friction of two surfaces one against the other.
2. Breaking effect on a liquid under pressure passing through a small orifice.
3. Superposition of the oscillations to be absorbed by those which are much shorter in an antagonistic spring.
4. Air compressed in a cylinder.

There is one point in the suspension of cars that is of especial interest, and that is the centralization of the masses of the car. This question is often ignored by drivers, whereas it should have a great deal of interest for them. It is a well-known fact that a high vehicle, such as a limousine or any covered car, has a tendency to slip in going around corners because the center of gravity is higher than in an open body, which is much lower. But the influence of the distribution of the super weight on the car is also important. One often hears among drivers conversations in which it is stated that such and such a car has a greater ten-

of the distance between the axles taken from the front (three-quarters at the outside). 2. It is necessary that the center of gravity of all the important bodies on the car—that is to say, the passengers, their luggage, heavy spare parts and tools—should be as near as possible to the general center of gravity. It is possible at the present day to make a car with a soft suspension, or, at any rate, greatly better a harsh car.

## British Army Taking Up Motor Transportation

*By the conversion of the present horse-drawn system of transports into a series of completely equipped motor supply trains the heads of the War Department expect to simplify the organization of the transportation service of the Expeditionary Force. An epidemic of motor car inventions has struck England during the past six months.*

THE British Army Service Corps is making a decided move in the direction of mechanical transportation, as the outcome of a number of years of experimental and development work. It is intended to convert the major part of the administrative transportation of the Expeditionary Force, both as relating to supplies and ammunition, into self-propelled transports. By the adoption of this method it is argued that a radical simplification in the organization of these services in the field will be wrought simultaneously. An epidemic of inventions relating to the motor car marked the first six months of the present year in England. These included solidified petrol; a type of coal-fuel engine; new kinds of valve gears, built "without seriously threatening the standard practice;" and a rotary steam engine. The inventor of this engine claims for it a really novel feature, which, he says, may be considered as endowing it with a chance to figure seriously in the evolution of the automobile. He declares that a signal virtue of the motor is the abolition of change-speed gears; the second advantage is found in a reduction of friction; and the third in the increase of steam tightness, the rotor bearing against two roller bearers, which in turn are freed from friction to some extent by being held up to their work by a steam cushion. That is to say, each roller bearer is made a floating fit in its own tunnel, while steam is admitted to a recess on the side of the roller, away from the rotor. Except for these features and the fact that it is constructed to run as a turbine when greater power is wanted, the engine in question does not appear to differ radically from the type of some other engines that made their appearance years ago.

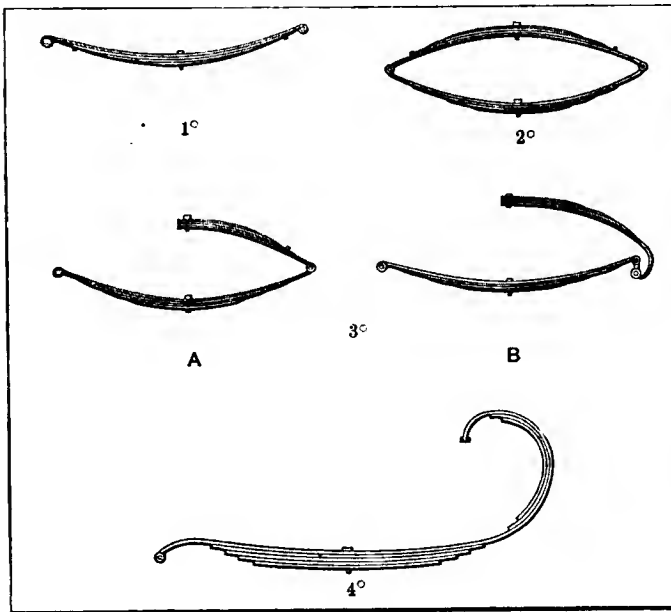

Fig. 3—Different types of springs used in automobile construction

dency to skid on corners than another because there is too much weight on the back axle. This is an incorrect method of explaining matters. This inconvenience does not come so much from the amount of weight of charge on the axle but rather from the great amount of distance that is present between the charge and the center of gravity. In order to reduce as much as possible this bad effect on the suspension it is necessary that all the important weight of the car should be as near as possible to the center of gravity of the general system (Fig. 4); in other words, it is necessary that the radius of gyration of each of the important masses should be as small as possible. Under these conditions the inertia effects on these same bodies will be much less on the holding properties of the car on the road surface, as their lever arms will be very small. Under the ordinary running conditions they can be in a vertical longitudinal plane, which is the gallop movement, alternately tending to surcharge one axle and alleviate the other, and it is dangerous for the tires and upsets the riding comfort of the car. In a vertical plane perpendicular to the axis of the car the rolling movement is less dangerous while driving in a straight line than when rounding corners. Finally in a horizontal plane there is a side rolling which is liable to cause a skid.

It is possible to see from this short outline how the centralization of the masses of a car has an effect on its holding properties on the road and also on the suspension.

The two following rules may be laid down: 1. The general center of gravity of the car should not be too high and about two-thirds

"DOING" THE CHATEAU SECTION IN AUTOMOBILES.—One concern in France is carrying passengers through the Château section of the country by automobile, the journey occupying six days, going and returning. The fare is 500 francs. Starting from Paris, the first day's run is to Chartres, the second is to Tours, the third embraces the vicinity of Tours, the fourth day leads the tourists to Blois, the fifth is passed in and around Orleans and on the sixth day the motor car fetches its passengers back and puts them down in Paris.

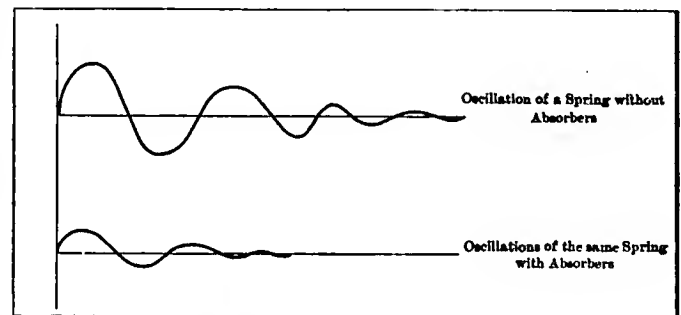

Fig. 5—Diagram showing the difference in the effects of a spring with and without shock absorbers

# Discussing Brick for Pavement

## Detailing the Vogue of the Best Results

*Will P. Blair, Secretary of the National Paving Brick Manufacturers' Association, illustrates and discusses the ramifications of brick pavement, presenting the ideas which should be uppermost at the time of laying pavement of this type, and offering suggestions that should be of interest to the automobilist, enabling him to intelligently advocate the building of good roads.*

In order to better understand the suggestions here offered a cross section is given by way of illustration. (See Figs. 1 and 2.) It will be noticed that the improved portion, including the ditch, occupies a width of 47 feet, so that at least 50 feet right of way is required for a like road. This is a type that has become very popular in northeastern Ohio. We give first attention to the manner and method of construction and the reason therefor, under the belief that the why should be known to the automobilist with as much reason as he should know why any part of his machine is made in this or that way. It is the advantage that appeals for favor, so right methods should persuade their use.

To assist drainage and avoid danger of heaving by frost, the concrete curb is made in form so that the base shall rest upon a sub-base of gravel, broken stone or cinders.

For draining the road bed in most soils, a small tile, laid parallel with the curb with T outlets at intervals of every 10 feet will answer; if, however, the soil is of such character that the water by capillary attraction fills to the uttermost, then to avoid frost action incident to our more northern climate, it is necessary to tile the road bed alternately as illustrated in Fig. 3.

Drainage is thereby assured quickly, avoiding the possibility of the ice obstructing the water, as often happens with lengthy drains, stopping the flow of water altogether.

The top of the curb shall be flush with the top of the pavement, so that the water will run off the pavement with even distribution at the lower edge, and therefore not liable to destroy the berme. After excavating to the required depth, care should be taken to compress the sub-foundation, rolling with a roller not exceeding 5 tons in weight. The surface should be made to conform to that of the finished street. The base should now be put in of concrete, using Portland cement 1 part to 8 of gravel or broken stone and sand. The gravel and broken stone should have enough of the smaller sizes which, with the sand, will fill the voids and assure such a mixture after the

water is applied as can readily be brought to a smooth surface conforming to the grade of the finished street.

Unless made smooth, the next step, that of preparing the sand bed and providing for a space along the curb for the expansion cushion, is scarcely possible. The sand should be spread by the aid of a template, and compressed to a uniform cushion by a hand roller weighing 300 to 350 pounds. This cushion should be uniformly two inches in thickness and thoroughly compressed. The support of the wearing surface will then be uniform under each brick, giving sufficient relief from the vibrations caused by the impact of travel, so that the cement filler subsequently applied will not shatter, and yet be a support that will greatly resist the weight of any load and prevent the filler bond from breaking and the brick from chipping. The expansion cushion should be put in last of all, but provision should follow the completion of the sand bed by placing a board along the curb, at least an inch in thickness for 14-foot roadway, and thicker for a wider road. This board should be made into two strips as shown in Fig. 4, held away from the curb by a piece of hoop iron hung over the boards, the longer end dropping behind the boards, so that when the time comes to remove the boards it may be readily accomplished by first taking out the hoop iron.

This board should remain in place until the road in all other respects is finished. The brick should be distributed along the line of work and piled outside the track which is being paved, taking the greatest care to protect them against mud and dirt. They should be laid on the bed thus prepared at right angles

with the street, with the best edge uppermost, and as nearly as possible so the jointing line will cover the center line of each alternate row. Bats should then fill the end openings. The important matter in this work is that the brick shall be placed best, or face, edge up in the first instance, not only making a smooth surface, but avoiding a second operation in the work which disturbs the uniformity of the sand cushion. The surface should then be swept clean of spalls and dust and rolled with a steam roller, weighing not more than 5 tons, rolled until the unevenness in the surface is rolled out, rolling both by moving the roller at right angles and at 45 degrees.

The next operation, that of applying the filler, is too often regarded as of minor importance, and details necessary to insure a perfect and durable pavement are ignored altogether, and while inexpensive and easy to comply with, a disposition to carry out in full the details is necessary or it will not be done.

The filler should be composed of one part each of clean, sharp sand and Portland cement. The sand should be dry. The mixture, not exceeding one-third of a bushel of the sand, together with a like amount of ce-

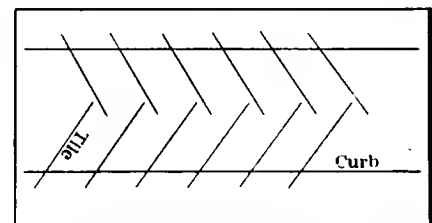

Fig. 3—Showing the diagonal courses of the pavement

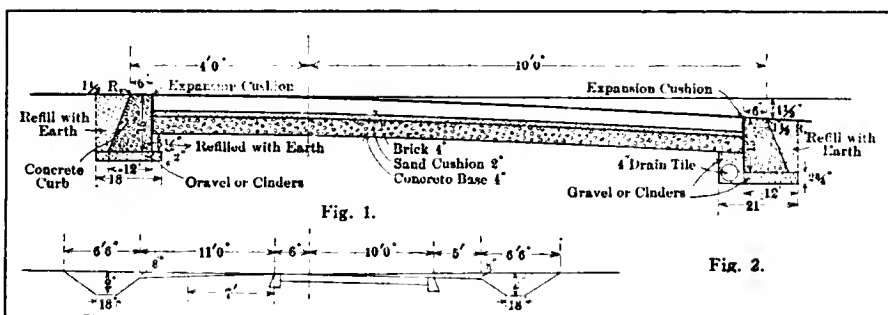

Fig. 1—Section of a brick-paved street showing the details of construction. Fig. 2—Dimensional information related to Fig. 1



ment, shall be placed in the box and mixed dry, until the mass assumes an even and unbroken shade. Then water shall be added, forming a liquid mixture of the consistency of thin cream.

The side and edges of the brick should be thoroughly wet before the filler is applied by being gently sprinkled.

From the time the water is applied until the last drop is removed and floated into the joints of the brick pavement the mixture must be kept in constant motion.

The mixture shall be removed from the box to the street surface with a scoop shovel, all the while being stirred in the box as the same is being thus emptied. The box for this purpose shall be 4 feet 8 inches long, 30 inches wide and 14 inches deep, resting on legs of different lengths, so that the mixture will readily flow to the lower corner of the box, the bottom of which should be 6 inches above the pavement. This mixture, from the moment it touches the brick, shall be thoroughly swept into the joints.

Two such boxes shall be provided in case the street is 20 feet or less in width; exceeding 20 feet in width, three boxes should be used.

The work of filling should thus be carried forward in line until an advance of 15 to 20 yards has been made, when the same force and appliance shall be turned back and cover the same space in like manner, except to make the proportions two-thirds cement and one-third sand.

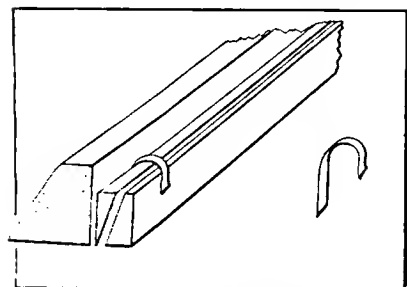

Fig. 4—Section through a curb, showing the expansion member

To avoid the possibility of thickening at any point there should be a man with a sprinkling can, the head perforated with small holes, sprinkling the surface ahead of the sweepers. Within one-half to three-quarters of an hour after this last coat is applied and the grout between the joints has fully subsided and the initial set is taking place the whole surface must be slightly sprinkled and all surplus mixture left on the tops of the brick swept into the joints, bringing them up flush and full.

After the joints are thus filled flush with the top of the brick and sufficient time for hardening has elapsed, so that the coating of sand will not absorb any moisture from the cement mixture, one-half inch of sand shall be spread over the whole surface, and in case the work is subjected to a hot summer sun, an occasional sprinkling, sufficient to dampen the sand, should be followed for two or three days. Grouting thus finished must remain absolutely free from disturbance or traffic of any kind for a period of ten days at least.

After this comes the last operation in finishing the street, that of removing the expansion board along the curb and filling the space so as to allow for the expansion. For this purpose a pitch or asphaltum mixture that will retain the greatest elasticity during low temperature should be used. This will often prevent expansion cracks even by low temperature and unquestionably prevent them during seasons of high temperature. An illustration of this kind of road is here actually given in Fig. 5 from a photograph of the same.

With many roads even put to excessive use a less width for the paved portion will be found entirely sufficient. It will be noticed that in the type here given it is provided for a seven-foot graded track alongside of the paved portion. If a road of less width is chosen the graded earth portion should be at least seven or eight feet in width and the paved portion not less than nine

MORE than 1,000 chauffeurs' licenses have been issued in the Province of Ontario. The driver's average wage is \$60 monthly. It is an exceptional case in which a driver receives \$20 per week.



Fig. 5—Reproduced from a photograph of a brick-paved boulevard

## As to the Silent Chain

*Apart from its quiet operation, the principal advantage of the silent chain lies in its flexibility, one of the most desired properties to be found in a mechanism. Liberal size and the best of quality as regards material will insure its success in operation.*

NOW that silent chains are coming into use quite extensively, discussion is being entertained bearing upon the reasons why these silent chains afford an extra measure of advantage, and it is more than likely that the discussion will lead to a point that has been too frequently overlooked in the past. Flexibility is one of the most desired properties that can be found in a mechanism, and the advantage to be derived from its presence can no more fittingly be illustrated than to call attention to a fact that a locomotive may pull as many as 100 freight cars, gaining speed from a standstill, under the conditions under which freight cars are built, taking advantage of a spring coupling, thus making it possible for the locomotive to start one freight car at a time, which is all that it does. Were the freight cars in rigid relation with each other it would be utterly impossible for a locomotive to start even a small part of the cars that compose a train under ordinary conditions. The secret lies in the flexibility that is induced by the spring bumper, and, come to think of it, the amount of play that is permitted by the bumpers is very slight indeed. The silent chain as it is being employed in automobile work has all the properties of the spring bumper that serves so efficaciously in freight train work, and it is fitting that advantage should be taken of this condition in favor of flexibility, since it is being found in practice that there are almost no disadvantages at all. The chances for mistakes are in the direction of using chains that are too small for the work to be done. A well-made silent chain is a relatively expensive device, and the influence would naturally be in favor of some method that would have a favorable influence upon the cost of the application of these chains. There are only two ways of reducing the cost of applying silent chains, one of which has for its basis the use of an inferior product, and the second idea is coupled up to the use of a well-made chain of a reduced size, considering the work to be done. It is not possible for a designer of acumen to take advantage of these ways of reducing cost, and the ultimate success of the whole project lies in the use of liberal-sized chains, leaving the quality above suspicion.

### Strong Desire to Get Out of Tire Troubles

Editor THE AUTOMOBILE:

[2,747]—I would appreciate an answer to these questions: (1) How can I remedy the following: I have a quick detachable straight-side tire, the bead of which has been stretched by allowing it to run flat. I have continuous trouble with these tires on account of their pinching or blowing out under the bead. I have tried wrapping tape around the rim, which, although it helps some, is not an absolute success.

(2) I have a Mitchell Model L 1909 car which has given me trouble by the rapid wear of the cones and ball bearings. When I take a wheel off to examine it I find the cones badly worn on the under side. After replacing with new cones and ball bearings I soon find them in the same condition, making, while running, a noise similar to the sound of the speedometer gears on the average car, although I pack the bearings with grease every month or so and see that they are properly adjusted. If you can give me any advice as to how to remedy this trouble it will certainly be appreciated.

(3) When the differential on this same rear axle is packed with grease why should it leak out around the brake bands or drums?  
A. V. M.

White Hall, Ill.

(1) The trouble in the tire is no doubt due to insufficient inflation or, perhaps, to a leak which takes place after a certain pressure has been attained. The pinch will take place at the top of the wheel if the car is standing or running with the tire flat. The accompanying illustrations (Figs. 1 and 4) will show the position taken by the tire at the top and bottom of the wheel when not pumped to the required pressure. The remedy is obviously to maintain the tire pressure required by the weight of the car.

(2) If the bearing is not adjusted too tightly, a trip to the repairman would probably be of benefit, as there may be something out of alignment. A little play should be allowed in the hearing so that after

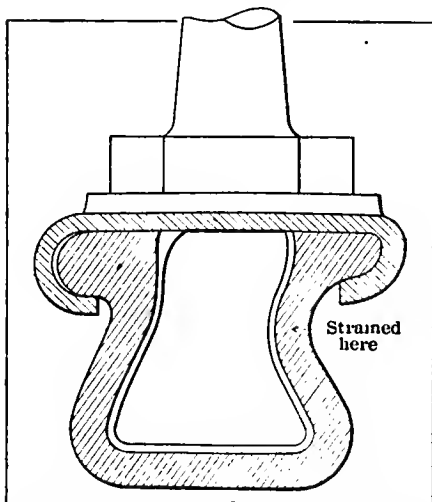
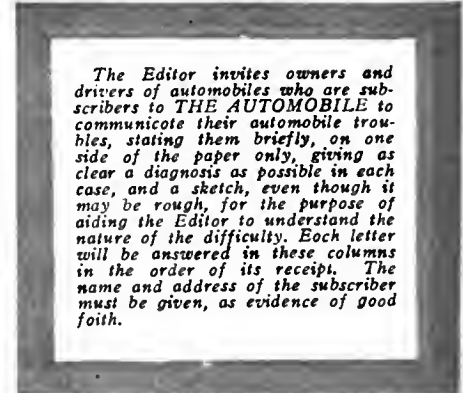

Fig. 1—Soft tire at the bottom of wheel being subjected to a severe bending stress

### What Some Subscribers Want to Know



spinning the wheel it will finally come to rest with the tire valve at the bottom.

(3) This tendency of leakage of the oil from the differentials into the brake drums is a common occurrence with a large number of cars. On the latest models the makers are using some device such as a baffle ring to prevent it.

### Another View of the Situation

Editor THE AUTOMOBILE:

[2,748]—In your issue of June 22nd, under the heading of "Short Stories of Common Interest," I note your article on "Lubrication," in which the lubricating oil is mixed directly with the gasoline. I have very carefully watched, during the last several months, these articles, especially as they have been explained by Charles E. Duryea, and your answers thereto. Now, I cannot see how anybody could have misconstrued the meaning of this method of

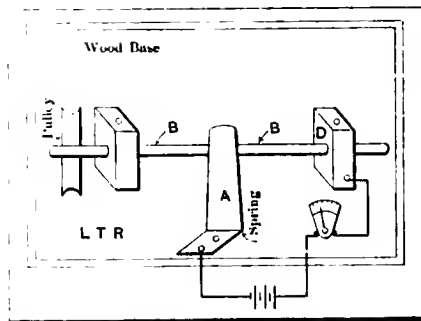

Fig. 2—Apparatus devised to test the presence of oil film between shaft and bearings

lubrication, for I am sure that Mr. Duryea frequently mentioned that its adaptation was only suited for two-cycle work. He did, however, in several articles, state that by adding a very small quantity of lubricating oil to the gasoline the running qualities of any four-cycle motor would be greatly improved. This I know to be true, as I have tried this method and am using it at the present time. I am sure he did not recommend this system for four-cycle work, to be relied upon as the sole method of lubrication. It was his contention that it would improve the running of the engine and meant that the regular method of lubricating should be employed as each maker originally provided.

Now in regard to the two-cycle lubrication in this manner, I must advise that my business relations have been such that I have had the honor of calling upon the majority of the two-cycle engine manufacturers and I find that where any of them have ever tried this method they are still using it and their enthusiasm in recommending this style of lubrication is great.

Recently a friend of mine brought up the question of this style of lubrication

and also of Mr. Duryea's talks, and he assured me that he used this system on several thousand engines, and that he found it to be without any question the most superior method he ever tried, and his experience covers at least nine years. He also advised me at the time that he would appreciate having his method of oiling brought to your notice. Disregarding all theoretical and technical arguments to the contrary, this sort of evidence would be most convincing to most of us and, to use Mr. Duryea's own language, I would say that "Facts are stubborn things."

Further in your article you say, "Authoritative statements emanating from high sources relating to the lubricating problem all go to show that it is the duty of lubricating oil to furnish an unbroken film between the journal and the box." Regarding this statement, I beg to advise that while I do not claim to be of this high source of authority, I do claim that this is absolutely wrong, as the following simple experiment will show:

Most of us know that lubricating oil is a non-conductor of electricity, at least of currents of 25 volts or less; therefore, if a film of oil is maintained between a journal and a shaft no current would flow through the circuit shown in the accompanying Fig. 2, which consists simply of mounting two pieces of brass with holes drilled in shaft B to bearing D, then from the voltmeter to the opposite side of the battery. If the oil maintained the above-mentioned film it would certainly insulate the shaft from the bearing and no current would flow or at least the voltmeter would fluctuate, showing a broken or interrupted contact.

You may, no doubt, be surprised to learn that the meter shows a perfectly steady current passing through this journal, clearly disproving the fact that the shaft is not in absolute metallic contact. In this experiment we have a pressure on the shaft of a spring of possibly five or six ounces. Certain it is that if the film of oil is broken by this light pressure, in an explosive engine where the pressure on the

# What Other Subscribers Have to Say

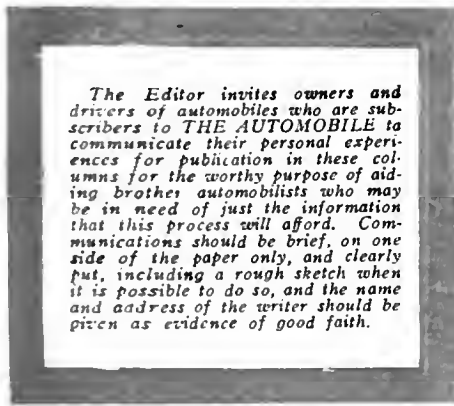

crankshaft becomes a number of hundred pounds, this argument of the oil film does not hold good.

The theory of the oil film has been handed down from one textbook to another and it seems that it has become a universally accepted term, just as some other theories have been allowed to pass from one generation to another. I have constructed the apparatus shown in the illustration for the sole purpose of verifying the authenticity of the argument.

I would not have answered the above article if it were not for the fact that I believe that Mr. Duryea's contentions are perfectly correct and that I happen to be in possession of this information, which is certainly authentic.

I earnestly trust that you will see fit to publish this in your valued journal, which is, to say the very least, an educational medium of the highest order.

LEWIS T. RHOADES.

New York, N. Y.

## Coat the Driving Faces of the Coupling with Solder

Editor THE AUTOMOBILE:

[2,749]—I have been troubled a great deal by the rattling of the Oldham magneto coupling. I have tried everything I can think of to remedy this, but it still continues. Can you suggest some other form of coupling that I might make myself which would overcome this objectionable feature?

ROBERT DENTON.

Wellesley Farms, Mass.

## A Knock in the Cylinder

Editor THE AUTOMOBILE:

[2,750]—Can you inform me what will stop a knock in the cylinders of my car? The knock seems to be a side lash from the pistons. Would you suggest reboring the cylinders, as the pistons seem to be in perfect order?

WM. FISCHER.

Evansville, Ind.

If the piston itself is in proper order

the knock is probably due to worn piston rings, which should be replaced. Another cause of knocking in the cylinders and one which is at times very hard to detect, is a loose wrist pin. If the cause of your trouble is neither of these two the remedy will lie as you suggest, in reboring the cylinders.

## Wants Information on Timing

Editor THE AUTOMOBILE:

[2,751]—Could you give me any information on camshaft and magneto timing? I have taken the camshaft and magneto off my motor and wish you would give me the correct setting so that I can get these back into their respective positions. It is a four-cylinder motor with a Bosch magneto.

A SUBSCRIBER.

Toronto, Canada.

The accompanying cut (Fig. 3) gives in graphic form the desired information. A very good practice is to put a center punch mark on the engine frame near the fly-

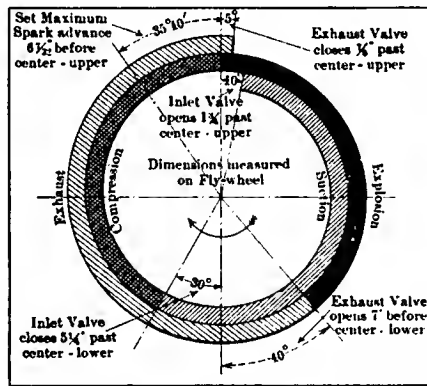

Fig. 3—Diagram for use in timing motors, giving the timing of a motor on a basis of flexibility of performance

wheel. Corresponding marks are put on the flywheel at each valve opening or closing and marked with the initials of the operation which takes place when the marks on the flywheel register with the mark on the casing. In this manner whenever the engine is taken down it may be assembled again without difficulty.

## Trouble with the Coil

Editor THE AUTOMOBILE:

[2,752]—For some time I have been having trouble with the ignition on my car. After having searched for a long time I have finally located the cause of the trouble and find it to be in the coil, as every other part of the ignition system is perfect. Could you give me any advice as to how to make any adjustments which may be necessary?

M. F. BRONSVELD.

Centreport, N. Y.

Your trouble is probably due to either

a badly adjusted vibrator or the contact screw of the vibrator may be loose. If the former, it may be adjusted as follows: Turn the engine over slowly by hand until the contact is closed; then turn on the switch and see if the vibrator will buzz. It should vibrate so rapidly that the sound produced is a sort of humming or singing sound. If this is done and the motor runs all right on low speeds and misses on high, the adjusting screw is too tight and the trembler has not time to vibrate well in this condition. The screw should be loosened.

## Has Compression Troubles

Editor THE AUTOMOBILE:

[2,753]—I have discovered leaks in the compression of at least one of the cylinders of my four-cylinder motor. I do not know what the cause of the leakage is or just where it occurs and would greatly appreciate any information you may give me as to how to proceed to remedy this. As I have plenty of time and a little mechanical ability. I would like to do it myself.

W. BOOTH.

Cairo, N. Y.

A good method to follow in testing for the location of compression leaks is to fill an oil can with water in which a small piece of soap has been dissolved, and pour this around every spot that a leak could possibly occur. An assistant should then turn the crank of the motor very slowly and all the spots into which the water has been poured watched for bubbles which will indicate a leak.

If no leaks are discovered in this way the valves should be ground with emery dust and oil, being finished with tripoli and water. If the leak has not been remedied after these processes the piston rings should be examined

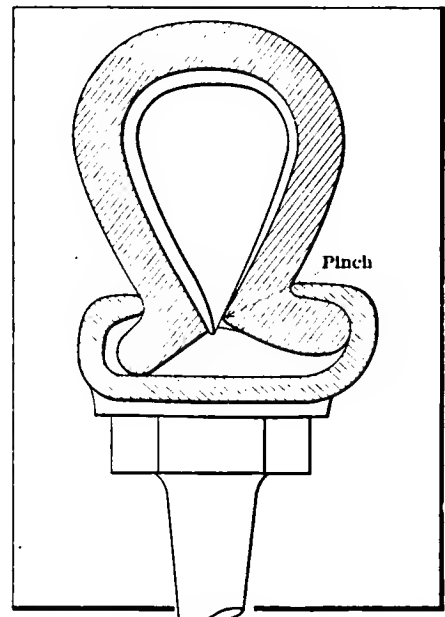

Fig. 4—Position of soft tire at top of wheel, showing how the inner tube is pinched

# Meeting Recurring Troubles Presenting a Series of the Most Probable Cases

A series of correlated short stories, accompanied by diagrams and characteristic illustrations, including the nature of the troubles that are most likely to happen to automobiles, discussing their causes and effects, all for the purpose of arriving at a remedy. It is the aim for the most part, to show how these troubles may be permanently remedied, and as a secondary enterprise it is indicated how the automobilist can make a temporary repair, thereby enabling him to defer the making of a permanent repair until a convenient time arrives.

**LUBRICATION OF THE KNOX CARS**—The Knox cars are lubricated by the De Dion force-feed system. The oil is kept in constant circulation by means of a pump. This pump is of the gear type and is operated by means of a vertical shaft, driven directly off the cam shaft and operating not only the oil pump but also the spark timer.

The oil reservoir is in the lower half of the crankcase and forms an integral part of the engine casing. The oil level in the reservoir is never allowed to come so high as to permit the connecting rods to dip into the oil, as this would cause too much oil to be thrown into the cylinders.

The gear pump draws the oil from the bottom of the crankcase and forces it through a main feed pipe over to the opposite side of the motor. The main feed pipe runs into a longitudinal pipe, meeting it at the center of the engine, thus distributing the oil in two directions along the pipe. From this pipe the oil is led directly into the main bearings by means of leads tapped into it.

The crank checks and crankpins are drilled to form an oil channel, and the oil enters this passage through an opening in the crankshaft at the main bearing. It then finds its way, being driven by centrifugal force, up into the crankpin, which has an opening leading into the connecting rod bearing. The connecting rod is also drilled, forming an oil passage up to the wrist pin. Oil is admitted to the connecting rod oil passage once in every revolution, when the opening in the connecting rod registers with that in the crankpin.

The cylinders are lubricated by the oil spray which is thrown off the cranks. The surplus oil from all the bearings finds its way back to the oil reservoir, from where it is again drawn through the system after having passed through a strainer.

There is a spring connection device on the pumpshaft, which, in case the pump should in any way become clogged, will snap by, thus preventing breakage of the more delicate parts.

A pressure gauge is located on the sloping floor board. The pressure may be varied at will by means of an adjustable by-pass located on the left-hand side of the motor. The by-pass must always be partly open in order for the system to work properly and should in general be set so that the gauge registers about four pounds pressure in the pump. For extreme speeds it may be allowed to run up as high as eight pounds.

The oil is supplied to the tank on the left-hand side of the motor, on which side there is also a means of removing the strainer from the reservoir and a pet cock showing the oil level.

**THE NATIONAL USES A CIRCULATING SYSTEM**—The oil in the National lubricating system is kept in continual circulation. The oil reservoir is located in the crankcase which is divided in such a way as to have an inner and an outer bottom. The outer or lower bottom carries the oil supply while the inner bottom is in reality a sort of tray inserted in the casting and moulded in so as to provide an oil trough below each cylinder.

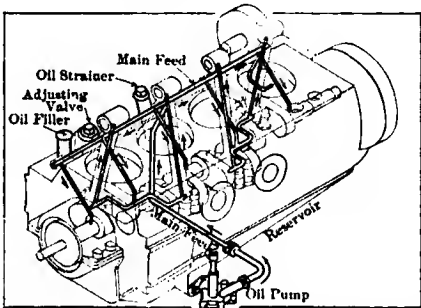

Fig. 1—The oiling system of the Knox cars, showing the course of the oil through the various leads by means of arrows

The connecting rods are equipped with scoop spoons which dip into the pools of oil which lie in each of these splash troughs. This dipping action throws the oil in the form of a spray into all the recesses of the crankcase and thoroughly lubricates all the moving parts located in the base of the motor.

To keep the oil in circulation there is a pump located within the crankcase which takes the oil from the reservoir in the base and forces it up through a sight-feed. After dropping through the sight-feed the oil returns by a vertical lead into the main oil pipe which runs the entire length of the crankcase and terminates in the lower part of the timing gear housing, which receives the oil in a small cup-like recess provided for the purpose. Some of the oil will be picked up by the timing gears and thus lubricate them, while the rest will overflow into the crankcase rapidly enough to keep the splash troughs full and overflowing. Above each of the crankshaft bearings

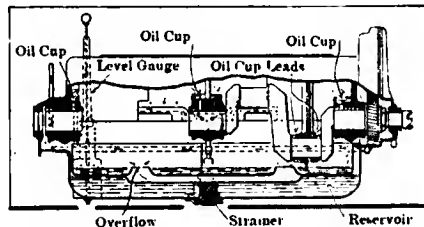

Fig. 2—Crankcase of the National, showing course of oil through the splash troughs and overflow pipes into the reservoir

there is also a cup which catches the oil from the splash and feeds it to the bearings through leads in the bottom of these cups.

All the oil draining off the bearings will join the overflow through the two standpipes provided, and return to the reservoir in the base. The course taken by the oil on its passage from the standpipes to the base leads through two pipes which join in the center of the base and then through an opening at the point of juncture of these pipes into a strainer of cylindrical form.

There is a level gauge on the side of the crankcase which shows at any time the amount of oil contained in the reservoir. This gauge is of the floating type with a ball located off the top of a vertical shaft projecting from the float. Drain plugs are provided in the bottom of the crankcase

**CORREJA "35 A" OILING SCHEME**—A combination of both the force-feed and splash systems is used on the Correja model "A" cars. The force-feed system is actuated by a pump which forces the oil to all the crankshaft, connecting rod and camshaft bearings. The pump is gear driven, being operated off the camshaft, and is located on the outside of the crankcase casting on the rear left hand side of the motor on the bottom.

The oil reservoir is in the bottom of the motor and carries the whole supply of oil. The pump lifts the oil from the bottom of this reservoir and carries it through leads to the various bearings mentioned above. After lubricating these bearings the oil will drain down into the splash troughs in the bottom of the crankcase. These splash troughs rest on a sort of tray above the oil reservoir.

The bearings supplied by the force-feed system will be given a greater supply of oil than can possibly be used by them, hence there will be a continuous overflow into the splash troughs which then become over supplied in turn, causing an overflow into the reservoir through the overflow holes provided for this purpose.

The connecting rods, even when running at a slow rate of speed, will descend into the troughs with sufficient momentum to dash the oil into a flying capor which completely fills the crankcase. This oily vapor will lubricate all the bearings not taken care of by the force-feed system.

The oil reservoir is filled through the breather tube. When the cover of the breather tube is removed the oil is poured down through the strainer

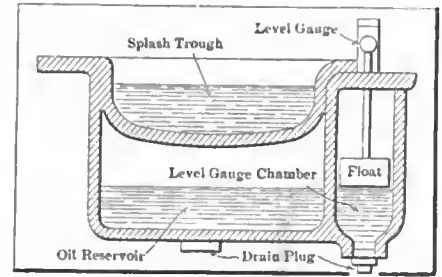

Fig. 3—Section through the Correja crankcase, showing the splash troughs and float level gauge

placed in the filler opening. There is a float level gauge on the side of the crankcase by means of which the amount of oil in the reservoir at any time may be determined by the operator.

The level gauge rests in a projection which is part of the crankcase casting. Beneath the projection carrying the float gauge there is a large drain plug. The oil level in the tank should never be allowed to sink so low that the little ball in the level glass is out of sight. It should be kept at about two inches from the bottom. As is necessary in a system of this kind, where the same oil is passed through the motor over and over again, a thorough system of straining is installed, the strainers being located in two places, viz., where the oil is supplied to the reservoir and again where it enters the pump.

**IN THE LUBRICATION OF THE BERGDOLL "30"**—The Bergdoll 30-horsepower 4-cylinder motor is lubricated by the splash system. The crankcase is divided into four splash troughs into which the connecting rods dip. Besides being divided laterally to form the splash chamber the crankcase is also divided horizontally in such a way that the casting has a double bottom. The upper bottom is moulded in such a way as to form the splash troughs just described. Below the troughs in what may be called the lower bottom of the crankcase the oil is carried in a plain basin-shaped reservoir.

The reservoir in the bottom of the aluminum crankcase casting is filled through the breather pipe. In filling, the cover of the breather is removed, disclosing the filler opening equipped with a strainer. The upper test-cock on the side of the crankcase is left open while tilting and oil is poured into the filler hole until it starts to flow from the cock. The cock is then closed tightly. The lower test cock is for the purpose of draining the reservoir, the oil never being allowed to become so low that there will not be a flow from this cock. The breather pipe is located on the exhaust side of the motor, just behind the magneto shaft. The oil is drawn from the reservoir by a pump which takes the oil from a suction pipe leading to the pump from the rear end of the exhaust side of the motor. The oil is then forced up through a vertical lead into the sight-feed located on the dash. Thence the oil flows down onto the opposite side of the motor and is led into the crankcase at the forward end. The oil from this lead will fill the front splash trough and then overflow into the second and from there to the third and so on to the rear. After reaching the correct level in the rear splash trough, the oil overflows back into the reservoir through an overflow in the rear of the crankcase.

Since the oil supplied by the pump is in excess of the quantity necessary to form the splash it will be continually overflowing back into the oil reservoir, thus keeping up a constant circulation. So that a pure supply of oil will be insured to the pump, a strainer is inserted in the system just before the pump through which all the oil must pass. The pump itself is located on the rear end of the exhaust side of the motor and is driven off the camshaft by means of gears.

The connecting rods dip into the oil while revolving and throw the oil in the form of a mist or vapor up into the engine, lubricating the entire motor, including cylinder walls, connecting rods, camshaft and main bearings. All these bearings will be oiled by the mist and in fact will receive an excess which will drain back eventually to the crankcase reservoir and be carried again through the system.

**VACUUM OILING SYSTEM OF THE E. M. F.**—The E. M. F. "30" car is lubricated by an en-

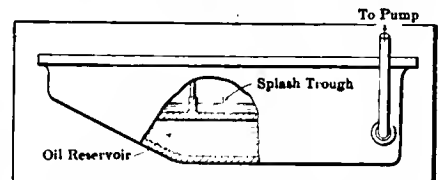

Fig. 4—Illustrating the oil pan casting of the Bergdoll with the lead to the oil pump



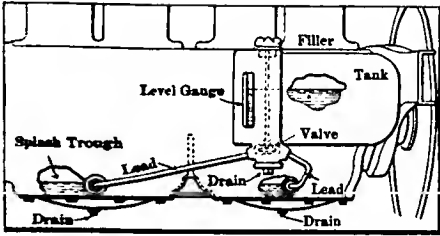

Fig. 5—E-M-F vacuum feed lubricating system, showing tank, level glass and leads to splash troughs.

tirely self-enclosed and automatic vacuum-feed splash system.

The oil tank is an integral part of the crankcase and is located on the left hand side of this casting. The capacity of the reservoir is about one gallon. The tank is filled through an opening in the forward end which is covered by a screw cap so made as to screw down tightly so as to form an air-tight fit over the oil reservoir. This tightness is an absolute necessity to the system as will be seen later.

The oil is fed into the crankcase splash troughs by vacuum. Two feed pipes extend from the bottom of the tank into the crankcase. These pipes are U-shaped, one end leading into the bottom of the tank, while the other projects through the bottom of the crankcase, to a point about five-eighths of an inch above the bottom. When there is no oil in the crankcase, but the reservoir is full, it can readily be seen that there will be a flow from the reservoir into the crankcase by means of these two pipes. When there is sufficient oil in the crankcase to cover the pipe ends, they will be sealed so that no air can enter them and hence no more oil may flow out of the reservoir.

This system automatically supplies the oil that is used just as rapidly as it is needed and keeps the oil level constant, since the pipes are continued into the crankcase for just such a distance as to provide the correct level for the splash of the connecting rods. The oil cannot rush into the crankcase and flood it when filling the tank as there is a valve which closes automatically when the screw cap is removed. There is an opening directly under the valve in the bottom of the oiler, through which the valve may be taken out for inspection in case of leakage. Any leakage would be detected while filling the reservoir.

The splash of the connecting rods throws a spray up into the cylinder and fills the crankcase with oil vapor. This oil vapor lubricates the entire motor, including the camshaft.

The camshaft gears are lubricated through an oil hole and by means of grease cups which are provided for this purpose.

In order not to waste oil certain precautions must be observed in the monthly cleaning to which the crankcase should be submitted. The filler hole cap on the oiler box must be removed so that the oil does not pour into the crankcase. The drain in the bottom of the crankcase is then opened until all the oil has poured out, when the drain cock is closed. Kerosene should then be poured into the breather pipes and the motor allowed to run for about fifteen seconds. The drain cock is then opened and the kerosene allowed to run out. After the drain cock is closed and the filler hole cover screwed firmly back into place the oil will run into the crankcase until it reaches its proper level.

**SELF-CONTAINED SYSTEM OF THE S. G. V. 20-30 CAR**—The lubricating system on the S. G. V. 20-30 is absolutely self enclosed. The machine is lubricated entirely by the force-feed system, although by adding a gallon more oil to the supply an auxiliary splash could be obtained. For all the requirements of the ordinary automobilist, however, the system is fully adequate as it stands.

The oil is carried in the base of the motor in a reservoir which forms an integral part of the crankcase casting. This reservoir is filled through an opening which is located just above the rear left hand crankcase supporting arm. To fill the crankcase the screw cap which covers the filler opening is removed and the oil poured into the

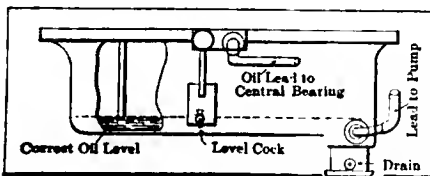

Fig. 6—The crankcase of the S. G. V. car, illustrating the oil well in the rear end to provide section for the pump

strainer which is located inside the filler opening to remove the foreign matter which is some times found to be in the oil supplied by the dealers, in spite of all the precautions taken to prevent such an occurrence.

In filling the reservoir, the cock on the side of the crankcase is left open. This cock is just at the correct oil level so that there will be no splash of the connecting rods into the oil as this would cause the motor to smoke since a sufficient quantity of oil is supplied to the motor by the force-feed system. In case of a splash there would be too much oil supplied and there would be danger of fouling the motor.

The oil is drawn from the crankcase reservoir by means of a suction pipe, and taken up to the gear pump which is located on the rear end of the camshaft. The pump then sends the oil under pressure to the main bearings where it enters the crankshaft after having lubricated the bearing. The pressure that is given by the pump is sufficient to overcome the centrifugal force at the main bearings and send the oil well along on its way to the cranks. The cranks are also drilled to provide an oil channel and the oil will be thrown through them by the force due to the rotary motion of the shaft. There is an opening in the crankpin through which the oil flows and lubricates the connecting rod bearing at this point.

The centrifugal force at the crankpins will force the oil up the leads in the connecting rod to the wristpin whenever the opening in the crankpin registers with the opening in the wristpin lead. At other times the oil will be thrown off the connecting rod bearings in a spray, thus lubricating cylinder walls.

There is a pressure gauge on the dash which shows the pressure on the pump.

The amount of oil supplied to the various bearings depends on the speed of the motor; an adjustment may be made, however, to regulate the amount of oil which will flow for any speed by means of an adjustable plunger on a by-pass through which the oil flows from the crankcase on the side of the motor. By increasing the

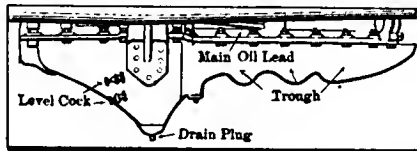

Fig. 7—View of the lower part of the Ford crankcase casting, showing the exterior of the splash troughs and the flywheel casing

tension on the spring which holds the plunger, the plunger can not be pushed back so far by the oil pressure, hence there will not be so large an opening for the oil to pass through, and the quantity will be diminished. In order to increase the supply at any speed the method of procedure is, of course, directly opposite.

The other bearings throughout the car are attended to in the usual manner by means of compression oil cups and oil holes. The transmission and differentials run in oil.

If the car has not been used for some time and the pressure gauge registers no oil pressure when the car is started, the priming cock on the top of the pump should be opened and a little oil poured in.

**LUBRICATION OF THE FORD CARS**—The Ford cars are lubricated by the splash system, the oil being kept at constant level by means of a circulating scheme keeping the oil constantly in motion.

The oil is carried in the base of the crankcase and also in the lower part of the flywheel casing, which is made oil tight by extending the cover plates of the crankcase so as to include the flywheel.

The flywheel proper consists of a number of permanent magnets arranged in a circle. These magnets form paddles which, when the flywheel is revolving rapidly, churn the oil in the bottom of the oil well into a vapor and lift it up into the upper part of the casing. Near the top part of the flywheel cover there is a funnel from which a pipe is carried

through the crankcase and into the front end of the oil pan casting.

The oil pan casting is divided into a series of troughs, which are moulded into the aluminum casting which forms this part of the engine. The pipe from the funnel leads directly into the foremost of these troughs. The walls of the troughs are all cast high enough to provide the proper level for the splash system to overflow when the oil rises high enough.

When starting on a trip the oil pan is filled to the level of the top of the trough walls and the flywheel casing is also filled to the level of the upper test cock, of which there are two located in the casing. The oil is poured in through a cup-shaped opening provided with a screen. It flows into the oil pan, down into the first trough, then, as more is poured in, it will overflow each successive trough wall, finally draining back to the flywheel casing. The top test cock is left open and oil is poured in until there is a flow from this test cock. The lower test cock is placed at the minimum permissible level.

The connecting rods splash into the troughs throwing the oil up into the cylinders, lubricating the walls and the wristpin. The camshaft is also lubricated by the splash. The excess oil drains back to the oil pan and flows gradually back to the flywheel casing.

There is a lead from the flywheel casing into the timing gears. The flywheel casing is also provided with a drain plug by means of which it may be emptied. The transmission and clutch are lubricated by the spray from the flywheel while the fanshaft and other bearings are provided with grease cups. The universal and axle bearings are packed in grease.

**OHIO SYSTEM CONTAINED IN CRANKCASE**—The Ohio motors are lubricated by a system which is contained almost entirely in the crankcase. The oil reservoir which holds about a gallon of oil is located in the lower half of the crankcase. The oil may be put into the reservoir in two ways: by pouring it through the breather tube or into the filler pipe which is located on the side of the motor.

Within the base of the crankcase and extending vertically there is a plunger pump, driven by means of an eccentric off the camshaft. This pump takes the oil from the base of the reservoir through a strainer tube projecting laterally into the reservoir and forces it up into the upper part of the lower half of the crankcase. This part of the crankcase contains a number of troughs into which the oil is fed by the pump in sufficient quantities to keep them constantly filled to such a height that a proper dip of the connecting rod into the oil will take place.

There is one of these troughs to each cylinder. As the rapidly revolving connecting rods are whirled into the oil pools contained in the splash troughs they churn the oil into a vapor which fully envelops the crankcase and lubricates every moving part contained therein. This includes the cylinder walls, connecting rod bearings, main bearings, camshaft bearings and cams.

After lubricating all the bearings the oil will drain back into the bottom of the crankcase and will pass through the system again, after being strained. A constant level throughout the crankcase is maintained by means of partition walls placed laterally across the crankcase between each pair of cylinders.

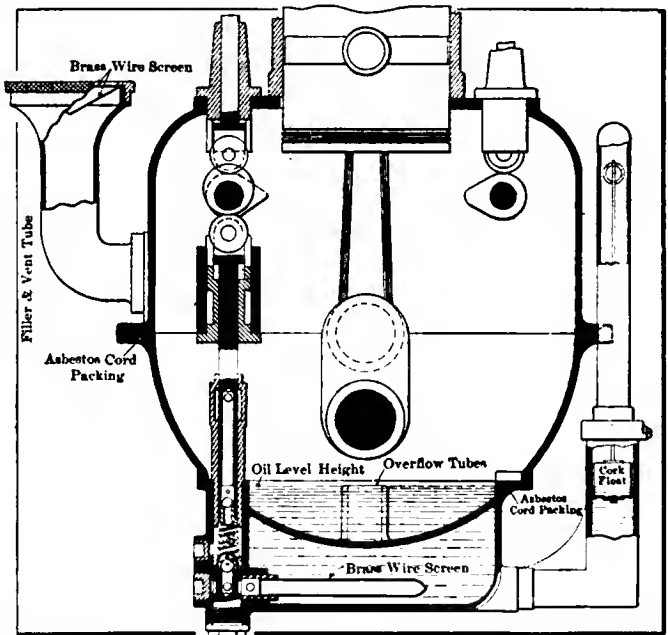

Fig. 8—Illustrating the interior of the Ohio crankcase. The pump, splash trough and reservoir are shown herein



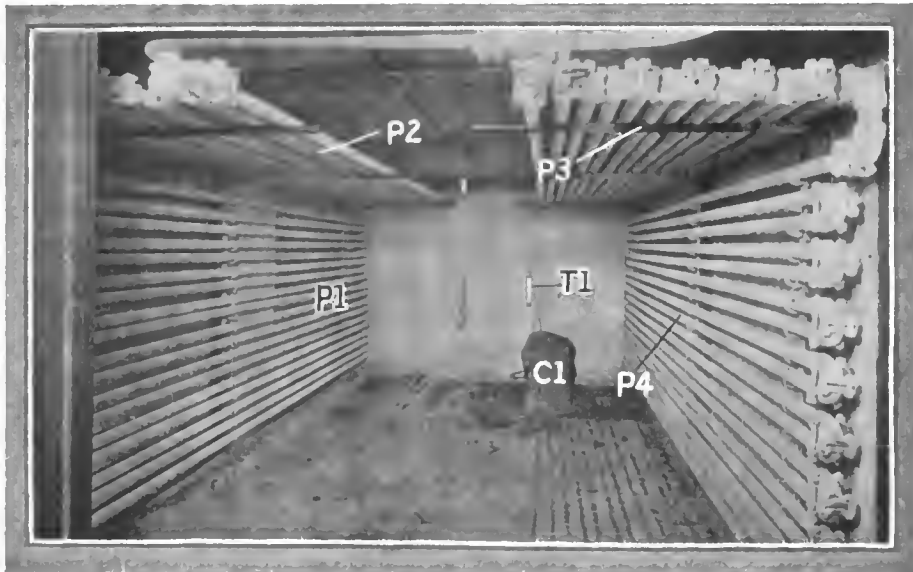

Fig. 1—Inside of the refrigerator used for testing carbureters, showing the banks of refrigerating pipes, with a coat of frost all over their surfaces

## Wheeler & Schebler Testing Equipment Discussed

*Illustrating the freezing equipment that has been installed in the plant of Wheeler & Schebler at Indianapolis, Ind., for use in the testing of carbureters under varying conditions of temperature.*

WHEN watches were first made it was found that they would not operate satisfactorily under varying conditions of temperature, and in the course of time a system was contrived for the adjusting of watches under conditions of heat, cold and position. It is a far cry from a watch to a carbureter in many ways, but there is no difference between watches and carbureters from the heat, cold and position point of view.

It was the idea of George Schebler when he built his first carbureter to so place the float that it would regulate the flow of gasoline to the nozzle, independent of position, taking into account the fact that when an automobile is going up or down a hill the "hydraulic grade" is disturbed from the level, and the flow of gasoline is accelerated or retarded accordingly, thus introducing a serious disturbing element, and Schebler thwarted

the designs of this disturbance by placing the carbureter float concentrically with the nozzle.

A further study of the carbureter problem brought to Messrs. Wheeler & Schebler the idea that carbureters should be adjusted for heat and cold while they are being tested in the plant, taking occasion to make any changes in design that might be suggested by the use of suitable testing equipment, involving the questions of temperature. It was quite apparent that nothing substantial could be gained by them in these directions in the absence of a refrigerating plant, and Fig. 1 shows the interior of the refrigerating room with banks of piping P1, P2, P3 and P4 around the sides and upon the ceiling of the room with a thermometer T1 in the vicinity of the rollers, which are connected with a dynamometer located in the adjoining room.

The walls of the room are suitably insulated, conforming to the customary practice in cold storage plants, and

the equipment employed for the purpose is shown in Fig. 2, consisting of a compressor C1 driven by an electric motor with a controller C2, power being delivered from the motor by means of a silent chain in the manner shown in the illustration.

The refrigerating liquid enters the system through container C3, and a bank of condenser pipes C4 is placed on the side wall of the refrigerator R1, access to which is had by means of the double doors D1. The expansion valve V1 controls the flow of the refrigerating liquid after it is compressed and cooled and freezing starts at this point, delivering the expanded refrigerating medium through the pipe P1 to the bank of pipes within the refrigerator as referred to in Fig. 1. After the refrigerating medium passes through the bank of pipes within the refrigerator and its temperature is raised due to the absorption of heat from the chamber, it passes back to the compressor, where a new cycle of work begins.

The refrigerating equipment above described is contrived on a basis of flexibility, thus permitting the temperature of the refrigerated room to be varied over a wide range at will, and to reduce the temperature of the room to 10 or 12 degrees below frost is a fair possibility, thus making it easy to test carbureters under the conditions of cold as they obtain in the North in the Winter time, varying the same to the heat of the tropics through all the degrees of temperature represented in this wide range.

## Chalmers Has Self-Starter

*Illustrating and describing the self-starter that is being introduced by the Chalmers Motor Company, of Detroit, Mich., as a feature of 1912 Chalmers automobiles.*

THIS starter is on the air pressure basis, the air being carried in the tank B with a capacity for air at the required pressure sufficient for the need. A check-valve A in the head of the No. 1 cylinder is responsible for the supply of air under pressure to the tank B which is carried beneath the body, supported

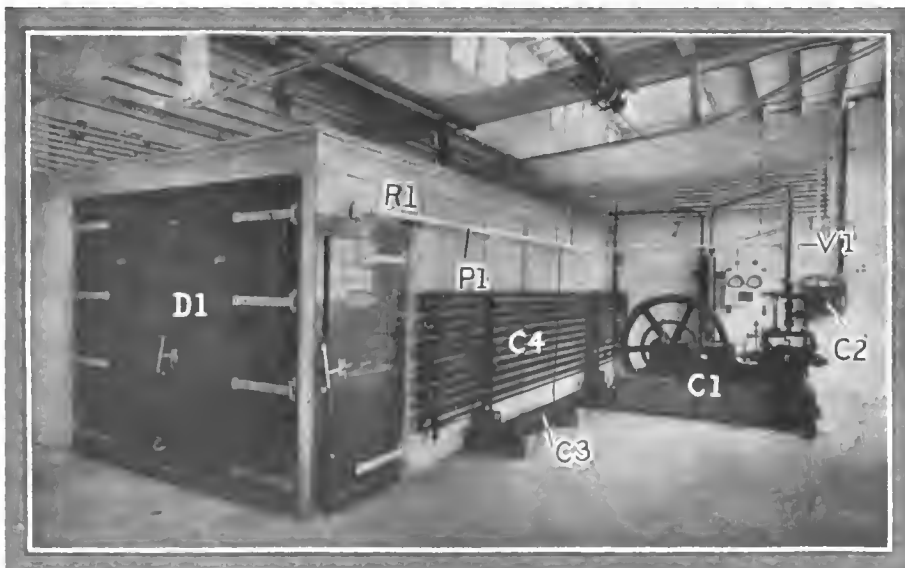
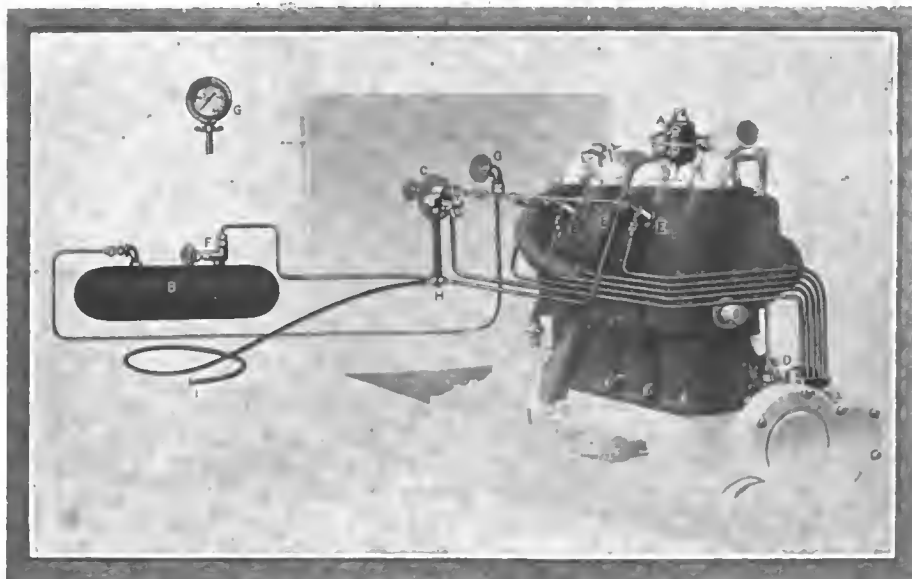

Fig. 2—Showing the compressor, condenser, method of driving the compressor, and scheme of piping the refrigerating medium into the refrigerating box

by the chassis frame. Control is by means of a dash-valve C which releases the air from the tank B, piping being provided to carry the air as released to the distributor D, delivering the same in proper time to the respective cylinders of the motor for self-starting purposes. It is the function of the distributor to deliver the compressed air to the cylinders that are ready for the working stroke in their order of firing. Cylinder valves E, one for each cylinder, afford the means for the entry of the compressed air under the control of the timer to the respective cylinders. A shut-off valve F is placed at the tank B, and a pressure gauge G serves as a tell-tale, enabling the operator of the car to observe the condition of the tank from the pressure point of view. For purposes of inflating tires a valve H is cut into the system and a length of hose is provided with a tire-end inflater I at the extremity, thus completing the equipment. In a word, the motors as provided with this self-starting system operate as compressed air motors for a sufficient time to permit the gasoline equipment to get under way in case it does not respond to the first few revolutions.



Diagrammatic presentation of the Chalmers compressed air self-starter as used on 1912 Chalmers automobiles

**BEER AND CHAUFFEURING DO NOT MIX IN LONDON**—Automobile owners in London are in a ferment over the subject of "Chauffeurs and Public Houses." An alarmist has appeared in print with the statement that "a drunken motor driver is surely more dangerous than an intoxicated constable on duty, yet the latter

is forbidden by law to drink in a public house, while the former can drink where and when he will. Many serious street accidents just lately have been due to intoxicated chauffeurs in charge of cars. Such mishaps could never have occurred had a little less liberty been given the drivers as regards the liquor they imbibed. Not that motor car drivers are all drunkards; but car driving, especially in London's congested streets, demands absolute sobriety to be at all safe. It would not be a bad plan to prohibit public houses from supplying intoxicants to uniformed motor car drivers when they are on duty."

## Calendar of Coming Events

### Handy List of Future Competitive Fixtures

**Race Meets, Runs, Hill-Climbs, Etc.**

- July 5-22.....Winnipeg, Man., Fourth Canadian Competition for Agricultural Motors.
- July 17-22.....Milwaukee Reliability Run, Wisconsin State Automobile Association.
- July 20-28.....Minneapolis Reliability Run, Minnesota State Automobile Association.
- July 22.....Guttenberg, N. J., Track Races.
- Aug. 3-5.....Galveston, Tex., Beach Races, Galveston Automobile Club.
- Aug. 4-5.....Brighton Beach, N. Y., Twenty-four-Hour Race.
- Aug. 7.....Chicago, Ill., Commercial Reliability Run, Chicago Evening American.
- Aug. 12-18.....New Orleans-to-Memphis Good Roads Tour, New Orleans Picayune.
- Aug. 12.....Philadelphia, Reliability Run, Quaker City Motor Club
- Aug. 12.....Worcester, Mass., Hill Climb, Worcester Automobile Club.
- Aug. 17.....St. Louis, Mo., Reliability Run, Missouri Automobile Assn.
- Aug. 25-26.....Elgin, Ill., Stock Chassis Road Race, Chicago Motor Club.
- Sept. 1.....Oklahoma, Reliability Run, Daily Oklahoman.
- Sept. 2-4.....Brighton Beach, N. Y., Track Races.
- Sept. 4.....Denver, Col., Track Races, Denver Motor Club.
- Sept. 7-8.....Philadelphia, Track Races, Philadelphia Auto Trade Association.
- Sept. 7-9.....Hamline, Minn., Track Races, Minnesota State Automobile Association.
- Sept. 12-13.....Grand Rapids, Mich., Track Races, Michigan State Auto Association.
- Sept. 15.....Knoxville, Tenn., Track Races, Appalachian Exposition.
- Sept. 16.....Syracuse, N. Y., Track Races, Automobile Club and Dealers.
- Sept. 18-20.....Chicago, Ill., Commercial Reliability Run, Chicago Motor Club.

- Sept. ....Denver, Col., Track Races, Denver Motor Club.
- Oct. 3-7.....Danbury, Conn., Track Races, Danbury Agricultural Society.
- Oct. 7.....Philadelphia, Fairmount Park Road Race, Quaker City Motor Club.
- Oct. 9-13.....Chicago, Ill., Thousand-Mile Reliability Run, Chicago Motor Club.
- Oct. 13-14.....Atlanta, Ga., Track Races.
- Oct. 16-18.....Harrisburg, Pa., Reliability Run, Motor Club of Harrisburg.
- Nov. 1.....Waco, Tex., Track Races, Waco Auto Club.
- Nov. 2-4.....Philadelphia, Reliability Run, Quaker City Motor Club.
- Nov. 4-6.....Los Angeles-Phoenix Road Race, Maricopa Auto Club.
- Nov. 9.....Phoenix, Ariz., Track Races, Maricopa Automobile Club.
- Nov. 9-11.....San Antonio, Tex., Track Races, San Antonio Auto Club.
- Nov. 27-30.....Savannah, Ga., Vanderbilt and Grand Prix Races, Savannah Automobile Club.
- Nov. 30.....Los Angeles, Cal., Track Races, Motordrome.
- Dec. 25-26.....Los Angeles, Cal., Track Races, Motordrome.

**Foreign Fixtures**

- July 21-24.....Boulogne-sur-Mer, Race Meet.
- Aug. 6.....Mont Ventoux, France, Hill Climb.
- Sept. 2-11.....Roubaix, France, Agricultural Motor Vehicle Show.
- Sept. 9.....Bologna, Italy, Grand Prix of Italy.
- Sept. 10-20.....Hungarian Small-Car Trials.
- Sept. 16.....Russian Touring Car Competition, St. Petersburg to Sebastopol.
- Sept. 17.....Semmering, Austria, Hill-Climb.
- Sept. 17.....Start of the Annual Trials Under Auspices of *l'Auto*, France.
- Oct. 1.....Gailion, France, Hill-Climb.
- Oct. 12-22.....Berlin, International Automobile Exhibition.

# THE AUTOMOBILE

Vol. XXV Thursday, July 20, 1911 No. 3

## THE CLASS JOURNAL COMPANY

H. M. SWETLAND, President  
A. B. SWETLAND, General Manager  
231-241 West 39th Street, New York City

### EDITORIAL DEPARTMENT

THOS. J. FAY, Managing Editor  
GEORGE M. SCHELL, Associate Editor  
JAMES R. DOOLITTLE HUGH P. MACCONNELL  
HANS WEYSZ

### ADVERTISING DEPARTMENT

W. I. RALPH, 1035 Old South Bldg., Boston  
C. H. GURNETT, } 910 South M. Chigan  
L. G. VOGEL, } Avenue, Chicago  
T. B. VAN ALSTYNE, New York and Phila.  
H. L. SPOHN, New York  
LOUIS R. SMITH, New York  
FRANK B. BARNETT, 309 Park  
Building, Cleveland  
H. H. GILL, 627 Ford Building,  
Detroit

Cable Address - - - - - Autoland, New York  
Long Distance Telephone - - - - - 2046 Bryant, New York

### SUBSCRIPTION RATES

United States and Mexico - - - - - One Year, \$3.00  
Other Countries in Postal Union, including Canada - - - - - One Year, 5.00  
To Subscribers—Do not send money by ordinary mail. Remit by Draft,  
Post-Office or Express Money Order, or Register your letter.

### FOREIGN SUBSCRIPTION AGENTS

ENGLAND:—W. H. Smith & Sons, Ltd., 186 Strand, London, W. C., and all book-  
stalls and agencies in Great Britain; also in Paris at 248 Rue de Rivoli.  
FRANCE:—L. Baudry de Saunier, offices of "Omnia," 20 Rue Duret, Avenue  
de la Grande Armee, Paris.  
GERMANY:—A. Seydel, Mohrenstrasse 9, Berlin.

Entered at New York, N. Y., as second-class matter.  
The Automobile is a consolidation of The Automobile (monthly) and the Motor  
Review (weekly), May, 1902, Dealer and Repairman (monthly), October, 1903,  
and the Automobile Magazine (monthly), July, 1907.

WHEN the users of automobiles awaken to the fact that over 50 per cent. of the entire cost of maintenance of cars is due to bad roads, improperly maintained pavement, and, as General Bingham put it, to red tape, it will be time for them to dispense with the tape and to call upon the officials who are charged with the proper maintenance of streets and roads to do their duty or retire from office, in order that men of action may take their places. In the meantime, the presence of red tape in a governmental bureau is probably more effective to conceal graft than it is to facilitate work, and the mere fact that an office is incumbered with so much red tape that the men therein are prevented from doing their work is a sign that something is amiss, and history has proven that appropriations dissolve in the face of such propositions; but it cannot be said that the people get a return for the money that is levied upon them.

\* \* \*

THOSE who advocate in a loud voice the building of good roads seem to confine their efforts to the mere building of roads, but when it comes to the matters involving the repairing and maintenance of these highways the great voices are silent and the roads fall into a wretched state of decay. The real question is, Do these advocates want good roads or are they looking for money? From the taxpayers' and the automobile users' point of view there is no sense in having good roads unless there is a proper system of maintenance so contrived and managed that the money invested in the making of good roads

will be conserved by the maintenance thereof. As an illustration of the waste of public funds that cannot be tolerated much longer it is only necessary for the reader to travel on the Albany Post Road for a few miles out of New York, when he will discover that the road builder has been busy on maintenance work for upwards of two years with no better result than the obstruction of the narrow road by a traction engine and a stone roller. In the meantime the roads are so bad that the traction engine gets stuck in the mud, but we have not yet learned of any good that might have been derived by the expenditure of funds in this effort.

\* \* \*

IT was only the other day that the Callan law was being reviewed by its author, who seems to harbor the impression that the law must have been a good one because he framed it, but he fails to appreciate the significance of the fact that this law was shot to pieces by the court and that it has so many imperfections in its make-up that even a one-day-old infant can legally drive an automobile if it so elects. We do not know who the "Senator" was afraid of, but he seems to have had an aversion to the framing of any automobile law that would compel the owners of automobiles to respect the rights of others, although workmen who make it a business to drive automobiles for others are compelled under this law to pay the cost of taking out a license, followed by an examination to show their fitness; but the funny part of it is that the examination as it is given to the average chauffeur would scarcely test the intellect of a scarecrow. That the automobile fraternity has had enough of the Callan law is a self-evident fact. That the public was ever infatuated with any of the provisions of this masterly piece of stupidity would be difficult to show.

\* \* \*

WHEN side levers that are used in the sliding gears show that they are incapable of doing the work for which they are placed, and that they are fastened on to the shaft with nothing more than a screw, and if the automobiles so made are designated as 1912 products the man who buys one of them will know that the maker thereof has a poor appreciation of the value of truth, or that he is too stupid to be entitled to the patronage of any man of intelligence. In the meantime there is danger to the public in the operation of an automobile on the highways if the side levers are insecurely fixed to their shafts, and it is believed that the time will come when the law will take a hand on the side of safety in the building of automobiles if the makers thereof do the things that cannot be sanctioned on any fair count. There is a possibility that agents practice the art of delivering second-hand cars as new ones, and that they juggle the factory numbers with the idea of deceiving purchasers who might get the impression that an automobile must be a new one if it bears a high serial number. Fortunately for the automobile industry the examples of this sort that come to the Editor are relatively few, but they reflect discredit upon the automobile industry and they hurt, perhaps more than anyone else, the men who represent fair dealing. There should be some way to snub these flagrant violations of common decency, and the makers themselves should regulate such matters rather than have the right to do so taken out of their hands by legislative bodies.

# Savannah Gets Blue Ribbon Events

## Grand Prize, Vanderbilt and Small-Car Races

*After much discussion it has been finally decided to award to Savannah the premier events of the American racing year. On Monday, November 27, the Vanderbilt, Tiedeman Cup and Savannah Trophy races will be run simultaneously over the 17-mile course, and on the following Thursday, Thanksgiving Day, the battle for the Grand Prize honors will take place.*

THE uncertainty which has existed for some time as to the time and place for the running of this year's Vanderbilt and Grand Prize races was set at rest yesterday by the announcement that the first-named classic would be decided over the Savannah course on Monday, November 27, and that the latter event would be fought to a conclusion over the same course on Thanksgiving Day, November 30. Concurrently with the Vanderbilt Cup race will be decided the fight for the Tiedeman Cup and the contest for the Savannah Challenge Trophy.

The Savannah course, slightly altered from last year, is approximately 17 miles in length. The conditions of the Vanderbilt race call for 17 circuits of the course—about 289 miles; the Savannah Trophy event, 15 laps, and the Tiedeman Cup race, 10 laps. In the battle for the honors in the Grand Prize race the contestants will be compelled to encircle the course 24 times—approximately 408 miles.

The race for the Tiedeman Cup will be a stock car event, open to cars of 161-230 cubic inches piston displacement. For the Savannah Trophy event stock cars of 231-300 cubic inches piston displacement will be eligible.

The entry blank for the Grand Prize race is quite comprehensive. Among the rights reserved by the promoting organization is that of ordering an elimination trial in the event of the number of entries being too large for safety, considering the length of the course. American and foreign cars are eligible to compete, though not more than three cars of any one make can be entered. Foreign entries must be made through the recognized automobile club of the country in which the car is manufactured.

The entrance fee for one car is \$1,000; two cars of the same make, \$1,500; three cars of the same make, \$1,750. Entries close November 15 with William B. Stillwell, care of the Savannah Automobile Club, Savannah, Ga.

### Blazing the Way to the South

WASHINGTON, D. C., July 17—One of the worst highways in this country is about to be taken in hand and in order to stimulate interest among the townships en route from Washington to Richmond, Va., under the co-operation of the office of Public Roads, the Association of Highway Improvement and the Touring Club of America, three automobiles will leave here on Monday next, July 24, carrying Paul D. Sargent, acting director of the office of Public Roads; J. E. Pennypacker, secretary of the Association of Highway Improvement, and Leroy Mark, vice-president of the Washington branch of the Touring Club of America. Henry MacNair, editor of the Blue Book, will act as pilot to the party. Meetings will be held along the line at the various stopping places. The road at the present time from the capital to Richmond is 179 miles, which would be consider-

ably shorter were it not for the numerous detours that have to be made. Richmond has been chosen as the scene of the first National Highway Conference, which will be held in October of this year.

### Overlapping Shows Will Crowd Metropolis

The selection by the National Association of Automobile Manufacturers, Inc., of January 10th to 17th as the dates of its show at the Grand Central Palace, and the combining of passenger and commercial vehicles in one show, will assure New York a full representation of automobile enthusiasts during the weeks in question. The Garden show opens on January 6th and closes on January 20th. The dates of the National Association show will, therefore, coincide with the last four days of the first week and the first three days of the second week of the Garden show.

It was not the intention of the National Association to ask the Motor & Accessory Manufacturers to participate, because it felt that its members would have enough to attend to with the Garden show. The Motor & Accessory Manufacturers soon made it plain, however, that it would expect to be admitted, and on Friday last arrangements to that end were completed. The Motor & Accessory Manufacturers will occupy 20,000 square feet of space on one of the upper floors.

### M. C. A. to Meet in Detroit August 10-11

At the annual meeting of the Manufacturers' Contest Association, which will be held in Detroit, August 10 and 11, one of the most important matters to come up for discussion will be the establishment of a new method for determining the weight limits in stock car events. Various other interesting subjects will be considered, among them the important matter of regulating competitions held on half-mile and one-mile tracks which were built originally for other than automobile contests. The association membership roll now includes 91 members.

### Guttenberg Races to Be Run July 22

Inability to get the track in condition in time, coupled with the failure of several racing stars to send in their entries owing to previous engagements, induced the promoter of the race meet scheduled for Guttenberg track on Saturday, July 15, to ask for a postponement of one week. The request was granted by the Contest Board, and the races will be run off on Saturday, July 22. Entries have been received of Mercer, Simplex, E-M-F, Overland, Lancia, Baby Regal, Correja, Schacht, Marmon, National, Mercedes, Abbott-Detroit, Pope-Hartford, Pullman and Buick cars.

### Brighton Beach 24-Hour Race Postponed

Having found it impossible to secure ten entries for the 24-hour race scheduled for Brighton Beach track on August 4. Promoter Moross has announced the postponement of the event till September 2 and 4, when an attempt will be made to feature it as a wind-up to that meeting. If this is found inexpedient the long race will be still further postponed.

## Chicago Orphans' Outing

*The four automobile organizations of the Windy City, donating 173 cars, unite in entertaining over 1300 little ones and 100 inmates from the Home for the Aged with a 30-mile ride over the breezy boulevards of the Western metropolis, with occasional stops in the parks for refreshments.*

CHICAGO, July 17—Local motorists gave the orphans and old people their annual ride Friday, when more than 1,300 children and 100 from the homes for the aged were taken out by the four local organizations, the Chicago Automobile Trade Association, the Chicago Motor Truck Association, the Chicago Motor Club and the Chicago Automobile Club. Chicago holds its outings later than other cities in order to be sure of the weather, and the wisdom of this course was apparent yesterday. No long stops were made at any of the summer parks. Instead the old people and children were put into 160 pleasure cars and thirteen trucks and taken for a ride over the boulevards. They went north first and a stop was made in Lincoln Park, where ice cream cones were handed out to everybody. Then the cars headed south and swinging through the two big parks stopped at the German building in Jackson Park, where more ice cream cones were handed out, after which the parade disbanded.

In all the cars were out 3 hours, in which time they covered something like 30 miles. No mishaps marred the afternoon and the children and old people all had a good time. It is a matter of note that all the children and old people were cared for, there being fourteen local institutions represented in the run. More than enough cars were provided. It was discovered that some of the institutions, evidently anxious that none of the children be overlooked, reported they had more than they really had. One instance noted was where 175 children had been reported, whereas there were only 125 when the cars called.

Credit for the outing belongs chiefly to Dr. H. A. Gunther and John H. Kelly, chairman and secretary respectively of the joint committee representing the four organizations, who worked night and day for a week to complete the arrangements.

## Quakers in Row with Mayor Over Fairmount Park Race

PHILADELPHIA, July 17—Owing to Mayor Reyburn's antagonism to the Quaker City Motor Club and his announced dissatisfaction with the organization's management of the Eastern classic last year, vigorous competition for the honor of conducting the fourth annual 200-mile Fairmount Park road race has developed, and although the Quaker City Motor Club has secured the sanction, the Philadelphia Automobile Trade Association put in a formal application to the Fairmount Park Commission at its monthly meeting yesterday for permission to hold the race. Owing to the fact that the contest cannot be held without



Fig. 1.—One of the Saurer trucks in the Chicago Orphans' Day outing, which carried more than a score of comfortably-seated children

adequate police protection, which of course would not be granted the Quaker City Motor Club in case the Mayor should persist in his opposition to the club, the automobile fraternity is up in the air as to the ultimate outcome. Despite Mayor Reyburn's indorsement of the Philadelphia Automobile Trade Association, members of the Quaker City Motor Club feel sanguine and are confident that the misunderstanding engendered between the Mayor and the club last year over the distribution of the receipts will be adjusted satisfactorily to their organization, the necessary police protection afforded, and the event conducted as in the past. The Q. C. M. C. is already armed with a permit from the Park Commissioners, in addition to the official sanction of the automobile governing body. Less than three months off, interest is already rife over the big event and a final decision from the city's chief executive is eagerly awaited.

Saturday, October 7, is the scheduled date for the race.

## Planning Trans-State Highway in Texas

GALVESTON, TEXAS, July 17—For the purpose of looking over and ascertaining the best route for the proposed highway from the northern boundary of Texas across the State to the Gulf of Mexico, a party occupying three automobiles left the Red River on July 10 for Galveston. The general idea is to construct across Texas from the Red River to Galveston a splendid highway, and then to encourage the adjacent counties to build good roads to connect with this highway.

## Good Roads Train to Tour Virginia

RICHMOND, VA., July 17—Automobilists throughout the State are gratified over the announcement of the Southern Railway that the good roads train of that system will tour the State. This train, which has just completed a tour of Alabama, Mississippi



Fig. 2—Line-up of automobiles that took place in the event—there were over one hundred and seventy of them in the affair

and Tennessee, has just entered North Carolina, and after traversing that State will come into Virginia, and will be here in Richmond on October 30-31 and November 1, at which time the National Good Roads Association will be in session here.

The good roads train is composed of three exhibition cars. Daily lectures are given by expert road men, illustrated with stereopticon views, charts and maps, showing the progress of good roads movement throughout the South.

## Ohio Second in Automobile Registrations

According to figures given out by the State Automobile Department, Ohio ranks next to New York in the number of automobiles owned and registered. Ohio now has 40,131 machines and New York 69,000. Pennsylvania trails along with about 39,000, with Illinois and Indiana a tie for the fourth place with about 35,000 each.



## Seventeen Entries So Far for Elgin Races

CHICAGO, July 17—With seventeen entries actually in for the American Automobile Association's national stock chassis road races on August 25-26, the Chicago Motor Club and the Elgin Automobile Road Race Association believe they will gather a field that will be larger than the one that went to the tape last year.

Entries of four Nationals and a Corbin were received Saturday, while to-day's mail brought in three Alcos. Besides these, the entries of three Falcars, as many Staver-Chicagos, two Coles and a Lozier had already been received.

The following trophies are offered for competition on August 25: Fox River Trophy, for stock chassis, 161 to 230 cubic inches piston displacement, minimum weight 1,200 pounds. Distance 137 miles. Kane County Trophy, for stock chassis, 231 to 300 cubic inches, minimum weight 1,500 pounds. Distance, 170



Fig. 3—Chicago orphans leaving Lincoln Park, where thirteen hundred kids enjoyed their first treat of ice-cream cones

miles. Illinois Trophy, for stock chassis, 301 to 450 cubic inches, minimum weight 1,800 pounds. Distance 202 miles.

The big event, for the Elgin National Trophy, valued at more than \$3,500, will take place on the following day, August 26, and as this event is open to stock chassis of under 600 cubic-inch displacement it is therefore open to those cars which will have competed in the three events on the previous day. In addition to the four handsome silver trophies big cash prizes will be awarded the successful drivers.

So far as the course is concerned, there is little left to do. Oiling has been going on for a week now and within the next few days the circuit will be inspected for faults that will be remedied before practice begins if any are discovered. The course has been very much improved and considerably widened, especially in the home stretch and at the turns. The bad Udina Turn has been widened until it is now 100 feet across.

1912 models will be eligible for the events provided stock certificates of descriptions are filed with the Contest Board on or before July 27 and are accepted by the Technical Committee, who will have charge of the technical affairs at Elgin.

### Booming Des Moines as an Automobile Center

DES MOINES, IOWA, July 17—"Make Des Moines the automobile distributing center of the West." This was the keynote of a big banquet participated in at the Hyperion Field and Motor Club Friday night when prizes and cups won in that club's "Little Glidden tour" were presented. W. E. Moyer, pathfinder for the tour and the man whose efforts are largely responsible for the tour, sounded the keynote and the sixty automobile men who were present enthusiastically pledged themselves to do their best to bring his prediction to pass.



Fig. 4—Chicagoans stopped, looked and listened wherever the orphans' merry army passed on its way

Fourteen cups which were won in the four-day, 450-mile endurance contest were presented by Earl Butler, referee of the contest.

D. S. Kruidneir, Des Moines agent for the Cadillac, drew the sweepstakes trophy, his car having finished without a penalty in either the road or technical tests. All three of the Des Moines daily newspapers presented cups.

Automobilists of Iowa are to meet in Des Moines this week, July 20, in an attempt to form a closer State organization to promote the interests of good roads. The meeting is called by H. B. Groves, vice-president of the Iowa Automobile Club, and practically every auto club in the State has been asked to send representatives. It is thought that several hundred will attend.

Although there is a big automobile show to be held at the Iowa State fair, the last week in August, Des Moines automobile dealers are already beginning to lay their plans for the third annual show of the Des Moines Automobile Dealers' Association which is to be held at the Coliseum next Spring. It is likely that the affair will be pulled off the middle of March, although no definite dates have yet been fixed. W. E. Moyer and C. G. Van Vliet, who managed the 1911 show, will in all probability be in charge.

### Cost of South Bend Auto Patrol Wagon

SOUTH BEND, Ind., July 16—At the request of the city administration Wilson E. Snyder, clerk of the Board of Public Safety, has prepared figures on the comparative cost of the auto patrol, which was placed in commission six months ago. During the six months it has been in use 1,010 arrests have been made and 2,504 miles covered. In the 12 months of 1909 there were 1,651 arrests and 2,927 miles covered by the horse-drawn patrol. The investment in horse and wagons and paraphernalia in 1909 was put at \$1,527, and the interest on the investment at 6 per cent., with the cost of operating for the year was \$1,101.80. In contrast is put the cost of operating the auto patrol for six months. Included in the figures is the cost for 27 days of last December. Investment, \$4,831.50; interest on the investment at 6 per cent. for six months, \$144.94; supplies, \$27.85; lubricating oil, \$21.25; hard grease, \$6.75; gasoline, \$59.36; repairs, \$37.26; total for six months, \$297.41. Estimated cost for operating for one year, \$594.82. Cost per mile run under the old system, 37 1-2 cents; with auto patrol, 12 cents.

### Doyle Joins the Timken Force

P. W. Doyle has severed his connection with the Long Manufacturing Company and on August 1 will join the sales department of the Timken Roller Bearing Company, of Canton, Ohio, and the Timken Detroit Axle Company, of Detroit, Michigan.

**Cleveland Reliability Starts in Heavy Rain**

CLEVELAND, O., July 18—With the sky black with clouds and in a pouring rain the 40 cars entered in the Cleveland News three-day reliability run left the Hollenden Hotel this morning promptly on schedule time. Many thought that because of the down-pour of rain the run would be postponed, but as all the contestants were willing to start the leader was sent away on time, the remaining entrants starting at three-minute intervals.

Mrs. Fred. C. Wood, the only woman driver in the run, laughed at the rain and started out with a seven-passenger Oldsmobile as a non-contestant. She carried her husband, two other men and two women and was given a great ovation as she pulled out.

Because of the rain that had fallen almost continually in the last 20 hours the drivers have had great difficulty in making the run on schedule time. Though the best roads were picked out for the route the rain has played havoc with more than one of them.

After plowing through mud and climbing rough hills the contestants arrived at Youngstown shortly before noon and were greeted by a great crowd that had gathered in the square. The stop marked the completion of the first 68 miles of the 533-mile trip. With the exception of a few punctures all the cars participating in the run went through without a breakdown of any sort.

The rain which had been falling in torrents let up during the morning and although the roads were very muddy and a number of drivers were obliged to put chains on their wheels, good time was made.

Farmers and their families greeted the contestants from every doorstep on the way, and at Chagrin Falls, Warren and Niles the citizens that had gathered in the town streets cheered the cars as they passed.

Tired, hungry, dirty, but enthusiastic, the contestants pulled into Wheeling Monday night completing the first day's run, which was equal to 212 miles.

With new supplies of gasoline and oil the contestants checked out of Wheeling, W. Va., at 7:30 in the morning, Tuesday, the second day of the tour.

At one o'clock Tuesday afternoon 25 of the contestants checked in at Zanesville. The van of the tourists reached Newark at 4 p. m.

Following is a list of the contesting cars:

No.	Car.	Driver.
1	Columbia	C. H. Tyler
2	Maxwell	C. G. Bleasdale
3	Velie	D. W. Iseminger
4	Velie	Harry L. Lance
5	Oldsmobile	Andy Auble
6	Oakland	Fred Krum
7	Cadillac	Tom Swan
8	Krit	John Rauch
9	Brush	E. McCoy
10	Firestone-Columbus	Harry Kortz
11	Garford	Ira Fouche
12	Buick	F. B. Smith
13	Jackson	C. D. Paxson
14	Regal	L. B. Moore
15	Regal	G. P. Sperry
16	Marmon	I. H. Greenwald
17	DeTamble	H. W. Orndorf
18	Abbott	R. E. McClellan
19	Peerless	T. S. Hammer
20	Bergdoll	F. A. Kaiser
21	Oakland	H. Bauer
22	Everett	J. Gardham
23	Stuyvesant	P. H. Brown
26	Cartercar	V. R. Hall
27	Krit	H. Higginbotham
28	Lion	H. Bloomstron
29	Norwalk	F. Taylor
30	Norwalk	T. J. Ruffel
31	Ford	F. E. Van Paton
32	Ford	A. H. Smith
33	Ford	H. J. Lytle
34	Mitchell	E. C. Lucas
35	American	C. Kagy
36	Van Dyke	F. J. Monsette
37	Reo	A. G. Bredbeck
38	Maxwell	G. A. Roberts

**Albion and Waterland Tour Together**

By the time that these lines appear in print the Prince Henry Trophy Tour will have been completed, and what is known as the Coronation Tour will have added another event to the history of the automobile movement. There was no attempt at a race this year, and the trade element was done away with, as the cars were identified by the names of their owners and not by the official name of the car.

WITH rumors of strife on the one hand the Teutons and Britishers have been mingling together in automobiles vying with each other for the supremacy of the road. The Prince Henry of Prussia Trophy is this year being competed for by members of the Imperial Automobile Club of Germany and the Royal Automobile Club of Great Britain and is a tour pure and simple. There is no semblance of a race and the cup is to become the property of a club and not an individual. In other words, it is an inter-club run over two kingdoms, the participants necessarily being members of either of the aforementioned clubs. Penalties will be inflicted for time delays at the rate of one mark for every five minutes. The replacement of a spare part necessitates the loss of 12 marks for every part replaced. Additional gasoline that may be required during the day after the start will be counted as a mechanical stop, but 30 minutes are allowed before the start for lubrication and replenishments and adjustments, after which the hoods will be sealed. The cars must be fully equipped with wind shields, tops and speedometers, and the regulations call for special regulations regarding body work in order to compell the entrants to use recognized patterns.

The German team entries total 42 while those from Great Britain number 30. The cars are entered by individuals and to eliminate the trade element the names of the cars are with-

A—Map of Great Britain, showing the route covered by the participants in the Prince Henry tour

B—Prince Henry of Prussia, driving his own car, starting the tour at Homburg

C—Duke of Connaught's car at the start of the tour

held from official publication. Army and naval officers of the respective nations will act as observers on the cars.

The illustrations depict the scenes at the start, the first car to leave being that of Prince Henry, with the Prince at the wheel. Homburg was chosen as the starting point and it will be remembered that this has been the venue for several memorable speed races including the Gordon Bennett, when the French wrested the blue ribbon of the road from their German "friends" who had won it the year previous from the British over the roads of the Emerald Isle.

The old Gordon-Bennett course was followed as far as Königstein where the route bears due north as far as Leun, and afterwards follows the course of the river Lahn as far as Limburg, whence the road leads via Montabaur to Coblenz. From Coblenz to Cologne, and from Cologne to Wesel, the course of the Rhine was followed, but from Wesel the route takes an easterly direction to Münster, famed for its old Rathhaus and plethora of churches, thus avoiding the Dutch frontier.

Cologne was the stopping-place on the night of Wednesday, July 5th, and the cars halted at Münster on the night of Thursday, July 6th. From Münster the direct route leads to Bremerhaven, on the mouth of the Weser, where the vehicles were taken on board a steamer specially chartered for the purpose of their conveyance to Southampton. On the night of Friday, July 7th, competitors slept on board, and also on the Saturday night; the steamer arriving in port on Sunday, July 9th. On the following day, Monday 10th, a start was made from Southampton due north through Winchester, Whitchurch, Oxford, and Stratford-on-Avon to Leamington, this being the first stop on English soil. From Leamington, still traveling north, the manufacturing towns of Leicester, Nottingham, Worksop, and the racing centre of Doncaster were taken en route to the famous inland watering town of Harrogate. Here the competitors stopped over Tuesday night, July 11th.

Leaving Harrogate, a detour was made through Thirsk, Helmsley and Easingwold in the Yorkshire moors before pro-

ceeding on the main road through Northallerton and Darlington to Newcastle-on-Tyne, the engineering centre of the north. Still following the Great North Road the cars passed over the Scottish border on Thursday, July 13th, and reached Edinburgh that night. Here, also, the competitors stayed over the whole of Friday, July 14th.

Edinburgh is the northernmost point on the route, so that on Saturday, July 15th, the southward journey commenced; its immediate destination was Windermere, Saturday night and the whole of Sunday, July 16th, was spent in the Lake District, and on Monday the two clubs continued to travel due south as far as Shrewsbury, where the night of Monday, July 17th, was spent. Having thus traversed the north-eastern border of Wales, the route continues due south through Ross and Chepstow, and then follows the banks of the Severn through Gloucester to Cheltenham, which was the destination on Tuesday, July 18th, and the last night away from home. From Cheltenham the route goes for a short distance due south in order to strike the Bath road at Chippenham, and then turns due east along this famous old coaching highway. The completion of the run was the occasion of a banquet at the Royal Automobile Club on Wednesday evening, July 19th.

### Twenty-six Contestants in Wisconsin Tour

MILWAUKEE, Wis., July 17—Twenty-six cars left Milwaukee this morning on a trip of practically 1,000 miles, the result to determine the awards by the Wisconsin State A. A. of four trophies donated to the organization by newspapers and individuals interested in motoring and the promotion of sportsmanship. It is the second annual reliability tour of the Wisconsin State A. A., the first being held from July 18 to 23, 1910. Emil Hokanson, whose car won the only trophy offered in 1910, by making a perfect score, is defending his honors in another Buick, a 1911 model.

The contestants in the trade or professional division are: Cadillac, three Buicks, two Imperials, Reo, Ford, Krit, Case, National, Overland, Franklin, Regal, Warren-Detroit and Petrel.

There are nine roadsters and seven touring cars in the trade class and two roadsters and two touring cars in the private class.

There are eight official cars, as follows: The official Kissel Press car; pilot, Overland, 53; confetti car, White Gas, 40; general press, Rambler, 63; pacemaker, Cadillac; technical car, Case; secretary's car, Palmer-Singer; physician's car, Buick, 21.

### Premier Tourists Pass Through Omaha

OMAHA, NEB., July 17—The Philadelphia tourists in Premier cars who are touring across the country were in Omaha from Monday evening to Wednesday morning, July 12. Coming through Iowa they found it fine going, until a heavy rain on Sunday made the progress considerably slower. In Omaha they purchased a camping outfit, and they expect to camp out overnight many times while they are in the mountains. There were still twelve automobiles and thirty-eight tourists in the party.

Some of them expressed mild surprise at not seeing the Indians running loose in Nebraska.

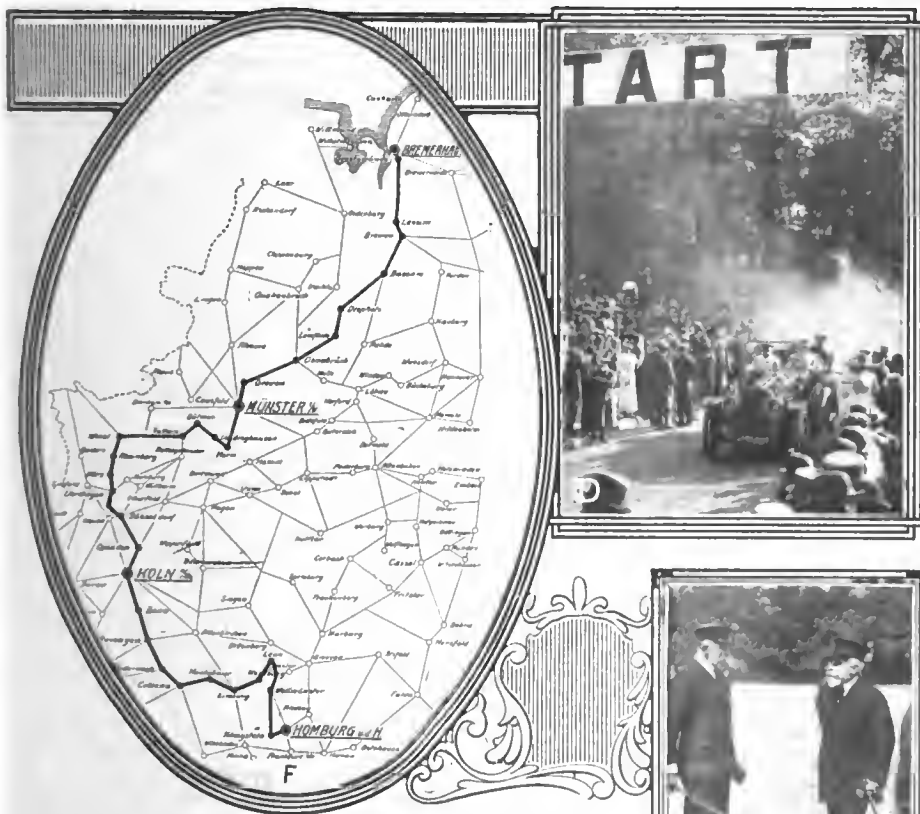

D—Spectators witnessing the start of the Prince Henry tour  
E—Prince Henry of Prussia in conversation with the president of the Imperial Motor Club of Germany before the start  
F—Map of the part of Germany covered by the tourists being divided into three stages

## Wisconsin's New Law Goes in Effect Aug. 1

MILWAUKEE, Wis., July 17—The Wisconsin Legislature has passed the consolidated motor-car bill and it has received the signature of Governor McGovern. The chief changes are as follows:

Annual registration, instead of present perpetual registration while car registered is in the hands of its then owner.

Annual fee of \$5.00 for registration. Present fee is \$2.00 for perpetual license. Proposition to tax by horsepower turned down.

Two licenses must be carried, front and rear. Only one necessary heretofore. The tags are furnished free upon payment of registration fee.

Red tail light must be carried in addition to one light on front as at present.

Speed limit in cities changed from 12 miles per hour to 15 miles per hour; in country, 25 miles per hour as at present. Proviso is included that no greater speed shall be used anywhere than is safe under the circumstances and conditions.

No person under 16 years of age may operate a motor vehicle, unless accompanied by a responsible adult.

Each city and village clerk must keep an up-to-date list of motor car and cycle owners, in booklet form, to be furnished by the Secretary of State and to be accessible to free inspection during business hours.

After paying the expenses of the department of the Secretary of State's office which attends to the registration work, three-fourths of the money accruing from the registration fee collection shall be transferred to county treasurers to be used in the repair of country highways, and the remaining one-fourth shall be used to augment the State highways fund.

A second offense against speed regulations shall be punishable by fine of \$25 to \$100, or imprisonment in jail not more than 60 days, or by both fine and imprisonment, at the discretion of the court.

No city, village, county, town, park board or other local authority shall have the power to pass any law or regulation interfering with or contrary to the State law.

Manufacturers are to have assigned to their testers a distinguishing number or letter, and this number or letter must be used whenever factory cars are driven on streets or highways of the State.

Any driver inflicting an injury to any person must stop and offer assistance and must always give name and address if requested. Failure to do either lays the offender liable to a fine of not more than \$100 or imprisonment for a term of not more than three months.

The new law goes into effect August 1. While present licenses are good until January 1, 1912, all cars registered after August 1 come within the new law and a fee of \$5 must be paid.

## Winnipeg's Show Is Quickening Trade

WINNIPEG, July 15, 1911—Western Canada is being saturated with information relative to the automobile, its efficiency and field, in this new country. The occasion is the second automobile show to be held in the West of the dominion and it is being held in connection with the twenty-first annual Winnipeg Industrial Exhibition. The machines of approximately seventy-five factories of United States and Canada occupy 40,000 feet of floor space in the manufacturers' building at the fair.

As an opportunity for meeting the successful townsmen and farmers of Western Canada the fair is without any equal. It draws from fifty to sixty thousand outside residents every year. During May the directors decided that the inception of an automobile exhibit might interest its patrons. The notice was published and within a week the 20,000 feet allotted was subscribed by agencies and manufacturers. A further allotment was made and entered for and ultimately the directors had to rush up a wing of 10,000 feet to hold the over-flow.

Since the opening day of the fair the automobile show has been the biggest feature of the exhibits. In all uncovered territory to the west agents are being appointed at the grounds and in addition hundreds of prospective purchasers are being listed. The local automobile and supply men state that the show is the best thing which has been held in the interests of the automobile in the west, exceeding even the winter show under the auspices of the Motor Trades Association.

Among the cars shown are the Chalmers, Mitchell, National, Ford, Buick, Packard, Overland, Hupp-Yeats, McFarlan, Inter-State, Republic, Shacket, E.M.F., Halladay, Hudson, Knox, Columbia, Maxwell, Patterson, Gramm trucks, Everitt "30," Paige-Detroit, Henry, Marathon, White, Warren, Brush, Gopher truck, Russell, Waverly, Olds, Reo, Detroit-Electric, Winton, Case, Speedwell, K-R-I-T, Hupmobile, Kissel, Empire and several others. In addition to these displays, dealers in accessories and supplies occupy several stands.

## New Use for the Automobile

During the recent heated spell in New York City in which over a thousand horses were incapacitated, several members of the New York Woman's League for Animals patrolled the hot streets in their automobiles in readiness to see that proper care was given to the beasts and that no overloading of the vehicles drawn by them was taking place. Due to the activities of this branch of the society, several arrests were made and convictions secured.

This league, which is doing remarkably good work, was formerly the Woman's Auxiliary to the Society for the Prevention of Cruelty to Animals, but since the object of the society is not so much correctional as to come in more intimate touch with those who own animals for pets or otherwise, a separate society has been formed.

## 150 Owners of Automobiles in Bozeman, Mont.

A considerable number of the most influential owners of automobiles in Gallatin County around Bozeman, Montana, are having meetings for the purpose of organizing an automobile owners' association, and Charles E. Dunlop, secretary of the Bozeman Chamber of Commerce, is authority for the statement that there are 150 automobile owners in that county, and that they are all in favor of a virile organization devoted to the interest of automobile owners.



Automobile Company starting on their annual outing to Pleasant Point, on Lake Ontario

### The Week's Doings in Detroit

DETROIT, MICH., July 17—Continued interest in long trips by motor trucks is noted locally. The Van Dyke delivery wagon which led the Affiliation tourists over the 800 miles of their run has been sent to Cleveland to take part in the Cleveland *News* run. The Saurer trans-continental truck passed through Detroit several days ago on its return trip to New York. Local manufacturers of trucks and wagons are almost daily sending their cars out into the country on trial trips. In addition, many of them are using factory-owned cars as demonstrators for local merchants' use. It has become generally recognized that the most effective form of salesmanship is found in this method. Rarely does it occur that a merchant consents to a demonstration of this character, without following the demonstration with an order for cars. The presence of the factories in Detroit has made demonstrations of this sort particularly applicable to the local situation and there is a marked increase in the number of delivery wagons and trucks, in active use this season, on the downtown streets.

One of the busiest factories in Detroit just now is that of the Brush Runabout Co. It is declared that contracts for the new Liberty-Brush have been closed during the past two weeks at an average of faster than 100 a day. The factory is producing 80 a day and this week started a night shift which will endeavor to keep up with the orders which the firm is receiving for the new car. The company is now engaged in the tabulation of a remarkable economy contest, conducted July 4 among its dealers all over the country.

James T. Shaw, treasurer of General Motors Co., is back in Detroit, after a two-weeks' tour in which he gave the company's new Welch-Detroit car a thorough test. Mr. Shaw made several detours in search of strenuous hill-climbing tests and found the car equal to everything asked of it.

The younger manufacturing firms still continue to find difficulty in securing representation, particularly in the smaller cities of the country. It is a generally admitted fact that there are fewer dealers in the country now and fewer additions this season than at any prior time in recent years. On the other hand, those dealers now in the business are virtually all of them well established and financially capable.

Detroit parts-makers and manufacturers of special machinery all feel the prosperity of the busy season and many of them are increasing their equipment. There will be several additions to their ranks next year, prominent among which will be the Henry & Wright ball-bearing drill press plant, which now has a building in process of erection near the plant of the Hudson Motor Car Co. The Cross Gear and Engine Co., 800 Bellevue avenue, has recently increased its capital stock from \$20,000 to \$80,000 and will materially enlarge the capacity of its plant.

The King Motor Car Co., which has 22 acres of land in the Jefferson avenue district and already has a factory building that is busy turning out cars, will soon break ground for an extensive addition. The firm has enlarged its orders for material and expects to build 3,000 cars of the 1912 model.

### Stephens Heads Federal Rubber Co.'s Chicago Branch

CHICAGO, July 17—George W. Stephens, formerly manager of the American Tire & Rubber Company of Chicago, and at one time advertising manager for the G & J Tire Company of Indianapolis, has been appointed manager of the Chicago branch of the Federal Rubber Manufacturing Company of Cudahy, Wis.

### Timely Hint for New England Tourists

The Touring Club of America suggests the following directions for avoiding the road construction between Pittsfield and Albany:

#### Mileage

- 0.0 Start Berkshire Hills Branch T. C. A. Hotel Wendell, Pittsfield, proceed on Blue Book Route 337 to Shaker Village.
- 4.6 Turn left (big white house on right).
- 6.9 Pass cross-roads, cemetery on left.
- 8.1 Turn right on dirt road, bear right.
- 10.7 Pass cross-roads, straight ahead, bear right, mill pond on right.
- 11.5 Pass white church on right.
- 11.8 Turn sharp right, Queechy Lake on right.
- 13.3 Bear left continuing to
- 16.7 New Lebanon, turn left passing white church direct onto oiled State road to Albany—follow Blue Book Route 337.

### Dorian Sales Force Reorganized

Mr. James T. Wallace has been made general sales manager of the Dorian Remountable Rim Company, with headquarters at 114 Liberty street, New York City. A. C. Marquardt will be Mr. Wallace's assistant. J. Franklin Duffy has been placed in charge of the Broadway office at No. 1804. The factory of the company has been removed to the Bush Terminal in Brooklyn.

### Electricity for the Man Who Wants to Know

Among the books of recent issue our attention has been called to "Practical Applied Electricity," from the pen of David Penn Moreton, B.S., E.E., associate professor of electrical engineering at Armour Institute of Technology; press of Reilly & Britton Company, Chicago; 438 pages, including index, in flexible morocco, adequately illustrated and carefully compiled. The price of this book is \$2, which is not too much to pay considering the fact that the whole range of electrical activities is brought within the narrow view of the reader who cannot afford the time it takes to obtain a substantial groundwork in technical literature. This book should be of value to the automobilist on account of the excellent information it gives in relation to batteries, and the fundamental principles of electricity, affording to the reader a clear understanding of the basic principles of every electrical device employed in automobile work. True, the book holds a wide measure of definite information that cannot be of great service to the mere owner of an automobile, but it is plainly put and it might prove of value as well as interesting to the owner of a car who will devote a little time to the reading of this handy volume.

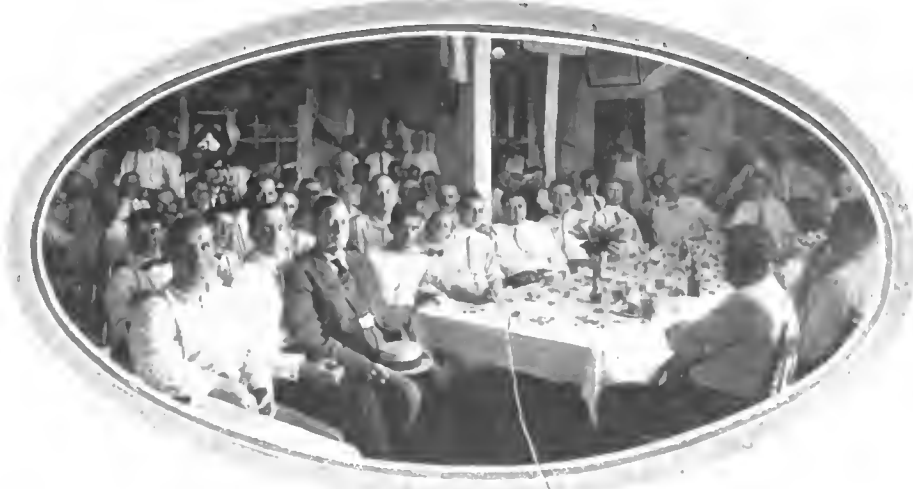

Members of the Overland Club at the dedication of their new clubhouse on the shore of Lake Erie, Toledo, Ohio



# New Things Among the Accessories

## Combination Electric Ignition and Lighting System

THE Matchless electric lighting and ignition system for automobiles and motor boats, manufactured by the Esterline Company, Lafayette, Ind., possesses some very unique features.

The equipment comprises a positively driven, magneto-type, direct-current generator, a storage battery and an automatic, self-closing, low-voltage, release, overload, reverse current controller. The generator is made to connect directly to the pump shaft in the same manner as an ignition magneto, without the use of a speed governor or speed-controlling device. It is supplied with complete ignition equipment, which can be omitted if desired, so that the ignition magneto can be retained or dispensed with, as the user may desire. If desired, the generator may be driven by gears or a silent chain, in case the ignition equipment is not used.

The use of a permanent magnet generator is made possible by the unique electric controller which comprises a part of the system. The controller has four distinct functions, as follows:

(1) To connect the battery to the generator when the voltage of the generator has reached the point where it will charge the battery.

(2) To limit the current through the battery to the normal charging rate, when the generator is running at high speed.

(3) To disconnect the battery from the generator whenever the voltage of the generator is less than that of the battery.

(4) To prevent the connection of the battery to the generator when the car is driven backward.

The controller consists essentially of a

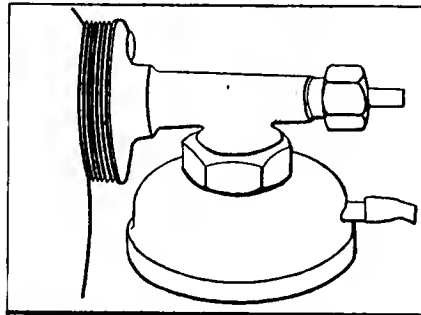

Fig. 2—Automatic pressure regulator on P. & B. acetylene gas-lighting system

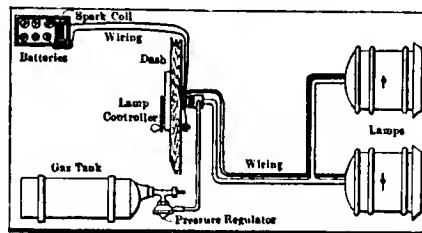

Fig. 3—Diagram of installing P. & B. illuminating scheme

die-cast metal case, over which is placed a permanent magnet, with pole pieces projecting into the case; a pair of coils surrounding the pole pieces, but capable of motion relatively to the pole pieces; a cover plate, which seals the case tightly, rendering it dust- and moisture-proof.

The force moving the coils is obtained by the reaction between the field of the magnet and the current in coils surrounding the projecting pole pieces.

All of the moving parts of the controller are mounted on phosphor bronze leaf springs, 1-2 inch wide, set rigidly in an insulating block.

The operation of the controller is such that all electrical circuits are opened and closed at the instant the current is zero. No current is drawn from the battery by the controlling apparatus.

With the car at rest or running at slow speed, the connection between the battery and the generator is open, but when the voltage of the generator becomes sufficient to charge the battery, the circuit between the battery and the generator is closed.

The space occupied by the controller on the dash is 2 1-2 inches x 6 inches, and it extends only 1 1-2 inches from the dash; the weight complete is 2 1-2 pounds. The metal case is water-proof, dust-proof and ornamental in appearance.

A four-point, back-connected switch is used, with the stem extending through the front of the controller case. There are four positions of the switch—lights off for day running, side and tail lamps for city streets and use while the car is standing at night, head and tail lights for touring and all lights on.

All wiring is on the engine side of the dash, where it is not exposed to view. Openings are provided in the front of the controller for plug connections to an exploring lamp for use in locating trouble, filling gasoline tank, etc.

The generators are made in two sizes; the smaller size has a capacity of 7 1-2 amperes continuously at 6 volts. The larger machine has a continuous capacity of 12 1-2 amperes at 6 volts.

The shaft is particularly heavy and rigid; the laminations of high-grade sheet steel are keyed to the shaft and the windings are imbedded in slots in the core.

The generator is made of sufficient capacity to carry its rated current without overheating and without the necessity of drawing in air and dust from the outside in order to keep it cool. It is geared or connected directly to the engine shaft or an intermediate shaft without any clutches, brakes or speed controlling devices.

An enclosed junction box is supplied with each equipment. This box is of sheet metal, with a removable cover, and contains a small insulated panel board, with provision for the necessary fuses for each circuit and connections for all wires.

An 80 ampere-hour battery is used with the small size and a 100 ampere-hour battery with the large size, and on account of the fact that it is impossible to overcharge a battery with this system any first-class storage battery can be used.

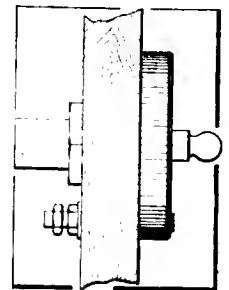

Fig. 4—Profile view of the P. & B. lamp controller

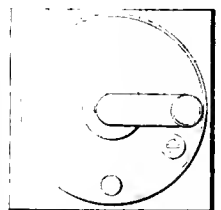

Fig. 5—Front view of controller for gas and spark

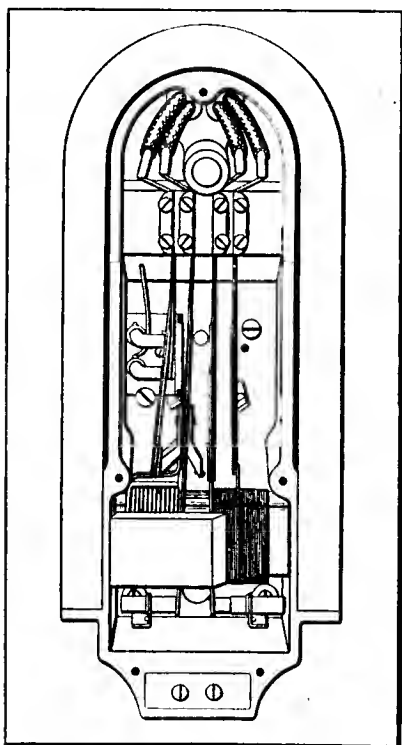

Fig. 1—Esterline automatic controller with cover plate removed, showing coils and method of supporting them

### Automatic Light-Lighting System

Evolution may be measured by the increasing speed of transportation facilities, this is only another way for saying that it may be measured by the general increasing tendency to automaticity. As technical developments progress, more and more work is taken off the hands of the operator of a device which is made to serve itself, in a way, thus producing in the mind of the operator a true picture of the agreeable situation termed simplicity. Automatic carburetion, lubrication and illumination are equally important steps in the developments of the modern automobile, the last named having taken no less labor in developing it than the other two.

Among up-to-date lighting systems acetylene is used widely for reason of its white light, which comes very near in intensity to the light of the sun. Its brilliancy is hardly approached by any other sort of artificial light, but this advantage has hitherto been coupled with the uncomfortable obligation of lighting the gas by means of a match, and with the further disadvantage of the driver being forced to regulate the outflowing stream of acetylene leaving the gas tank, since in course of time, as the gas is being used up, the initial pressure in the tank falls off very noticeably. The work of adjusting the nut of the tank, while it is not a hard one, is considered very uncomfortable by many automobilists, and it is just this class of motorists, whose number, by the way, is legion, that are ready to install on their cars a new system, doing away with the acts above described, especially if the price of the lighting system is not too high.

An automatic acetylene lighting system designed for the army of progressive automobilists is illustrated in Fig. 3, which shows the manner of laying out the connections for the gas as well as the low-tension current, leading from their respective sources to a controller on the dash and thence to the headlights. The system here shown consists of three special devices combined to advantage, which are the pressure regulator and the controller, in addition to which there is a special construction of igniter which is located in the headlight. The automatic pressure regulator is of the nature of an automatically adjusting valve

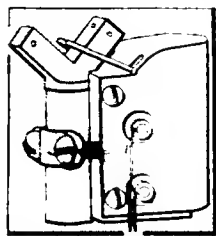

Fig. 6—Igniter incorporated in P. B. system

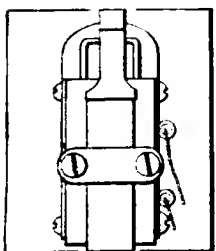

Fig. 7—Profile view of the acetylene igniter

through which the gas passes; and it is a feature of the regulator, which is seen in Fig. 2, that while the gas pressure in the tank may be up to 225 pounds per square inch, the acetylene after it has passed through the regulating device has a pressure of but 2 ounces per square inch, which is equal to the weight of a water column 3 inches in height.

In Figs. 4 and 5 is seen the lamp controller, both in full-face and in side view. The small key seen in the illustration indicates the only way by which the entire system is operated, in that it both serves to close the current, which enables the spark coil to produce a spark at the igniter in the lamp, and at the same time raises or lowers the gas flames by a regulating valve interposed in the gas lead at this place.

The igniter is of unique construction and securely fastened to the acetylene burner as shown in Figs. 6 and 7. The two wires leading from the battery and coil to this point of the system are connected to the two screws seen in the cut, and connection is made through the interior of the igniter to the two points forming a spark



Fig. 8—Sanitary goggles are of little weight

gap right above the center of the double burner. This arrangement is a guarantee that when the key on the dash is so turned as to permit the gas to flow to the burner, the current from the spark coil is closed at the same time, and a spark made to appear in the gap of the igniter wires, thus insuring positive and prompt ignition of the gas admitted from the tank to the headlights.

The system is named Motor-Light Lighter, and is the product of the P. & B. Manufacturing Company, being made at the plant of that concern, which is situated at 376 Birnie Avenue, at Springfield, Mass.

### Light and Sanitary Goggles

AMONG the drawbacks of touring, assuming the roads to be fair, there is none greater than the disagreeable sensation of a strong air current striking the eyes of driver and passenger, and while it is sometimes not a desirable course to shut out all the air by means of an erect windshield the eyes of the occupants should

always be efficiently protected. Fig. 8 shows the latest accessory constructed to serve this purpose, viz., the sanitary goggles, which is made of one piece of transparent and colorless material that does not obstruct the work of the eyes in any way, while the lining is of a soft and strong fabric. The whole thing is comfortable and simple, and protects the nose as much as the eyes; furthermore, the price of the goggles is low owing to its simple construction. The Sanitary Sales Company, of Bradford, Pa., produce this novel device.

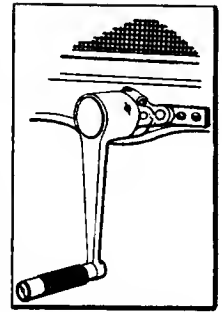

Fig. 9—Safety crank which is back-kick proof

### Auto Safety Crank

ACCIDENTS owing to a back-firing motor are met with, at times, even by skilled drivers, and when the trouble and pain of a broken arm are vividly pictured in the mind, there will be hardly an automobilist to deny that an insurance against mishaps of this kind will be worth some expenditure, just as the majority of car owners do not hesitate a long time to take out a policy protecting them from loss in case of the car being damaged by fire. The illustration of the Auto Safety Crank which is offered herewith, represents the latest achievement along the line of back-kick insurance, and being of substantial construction and high-class material, it is sure to live as long as the automobile it is installed upon. The wax engraving shows the manner in which the device is attached to the front cross bar of the chassis frame, indicating the strength of the apparatus. This crank is made and sold by B. F. Perkins & Son, Inc., Holyoke, Mass.

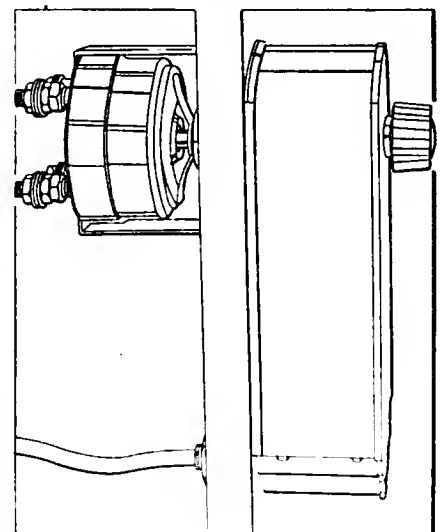

Fig. 10—Side view of Esterline automatic controller, with portion of dash cut away to show rear connected switch

## Seen in the Show Window

**M**ATERIAL and workmanship of a high class together with up-to-date equipment are conditions which make the manufacture of strong and efficient bearings possible. The attention which engineers have paid to their constructions for not a few years, therefore, has not been exaggerated by any means, but the result of their endeavor has shown that the efforts made in this field duly paid for themselves. A good bearing, if it is well lubricated, out-lives millions of revolutions of a shaft under heavy load. An illustration of a standard product is herewith afforded (AW), this being the Bower roller bearing, made by the Bower Roller Bearing Company, of Detroit, Mich.

**E**XCESSIVELY high temperature is hard on any man's system, but never does heat make itself more felt than when there are no cold drinks to counteract it. For the Summer time the Hawkeye refrigerator basket will be found useful for transporting food and water fresh and cool for a day. This enables the use of many dishes which otherwise would have to be done without. The basket shown at (AX) is made of strong, tough rattan, woven and bound to stand hard use. It is lined with nickel, which makes it sanitary and rustproof. An asbestos layer is placed between metal and fiber walls, insuring good thermal insulation, and very little ice is required to keep the temperature down. The Burlington Basket Company, 44 Main street, Burlington, Ia., is the maker.

**A**IR pressure in tires is an important factor in the cost of their use, and authorities hold that every driver ought to be equipped with an instrument for measuring tire pressure, since gauging the same by kicking the outer casing and then judging from the resistance is a method not even deserving the title of "rule-of-thumb." The Brown indicator (AY) is permanently screwed on to the tire valve, thus showing the pressure within at all times, and to inflate the tube the gauge is not removed, but the pump is connected up to the valve of the indicator. Comfort will surely be found in this arrangement, and in addition to the clear readings it gives the gauge is so made and installed that it is not harmed by the revolutions of the wheel. It is the product of the Brown Company, 1091 South Clinton street, Syracuse, N. Y.

**T**HERE are several methods of repairing damaged tires by means of vulcanizers, and these differ mainly in the nature of the fuel, some using alcohol to produce

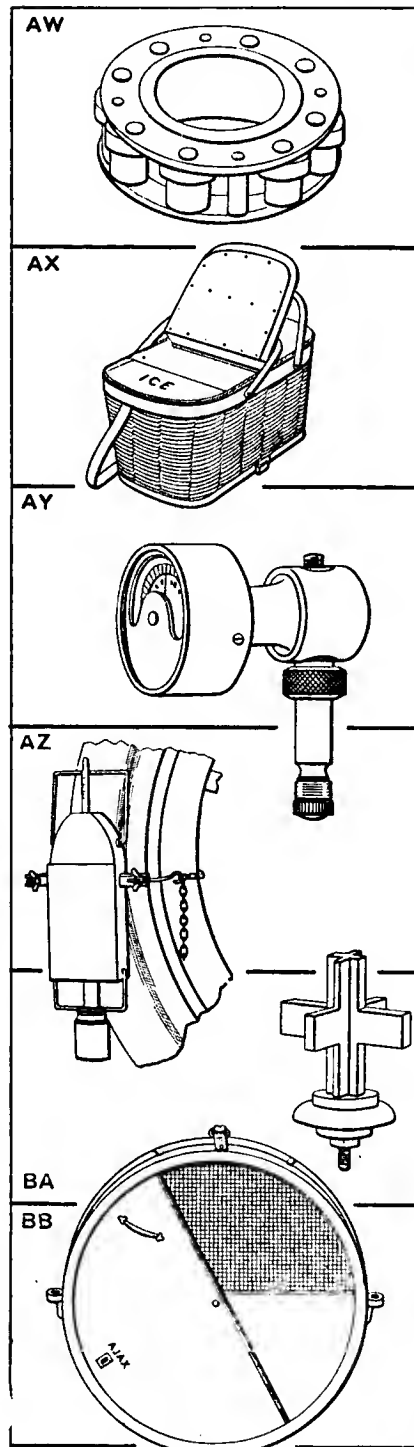

AW—Illustrating the Bower Roller Bearing, a standard product

AX—Hawkeye Refrigerator Basket keeps cool twenty-four hours

AY—Brown Pressure Indicator stays on tire for good

AZ—National steam type of vulcanizer may be securely attached

BA—Red Cross signal to be placed on physician's radiator filler cap

BB—Ajax revolvable door trunk for transporting reserve tires

the necessary heat and others electricity, while with a third type, applying steam for the purpose, it is claimed that overheating and consequent injury of the tire are positively avoided. As an example of this latter type the National steam vulcanizer is here illustrated (AZ), in which the water is heated in a miniature boiler by means of a small burner placed underneath it. In its shape this vulcanizer is rather conventional and, as the illustration shows, it is easily and securely attached to the tire. It is made and sold by the National Motor Supply Company, 1919 Euclid avenue, Cleveland, Ohio.

**U**NWRITTEN laws will always command some consideration for the physician violating speed ordinances while on business bent, unless he seriously interfere with life or property of others in the pursuit of his duties. Nevertheless, a doctor who drives his own car will grant that he would preferably save his nervous energy for other purposes than to keep an anxious lookout for pedestrians on his way to a patient, when his mind is generally occupied with important matters. Therefore, a sign clearing the way for his car will be a good thing for a physician to place on his car in a conspicuous position; and this want is being filled by the Red Cross Radiator Ornament, placed on the market by the Motor Car Equipment Company, of 55 Warren street, New York. The cross, which is shown at (BA) is 3 inches high and 2 1-2 inches wide, finished in ormolu gold with either red or green enamelled sides. The ornament will be recognized by everybody and very effectively secure the right of way.

**R**ESERVE tires are frequently carried along by tourists, and it may be seen from the manner in which these tires are stored whether their owners belong to the class of careful automobilists or not. These powerful and yet sensitive shoes of the automobile, while they are able to withstand a great deal of strain if kept in good shape, will deteriorate most rapidly if exposed to moisture and sunlight for some time. The value of an efficient trunk for reserve tires is not to be underestimated, and among the several classes of casings the revolving door type is quite popular. An example of this kind of tire trunk is here shown (BB), the door of which revolves in a continuous steel channel, making the trunk perfectly rigid. This trunk is made by the Ajax Trunk & Sample Case Company, 91 Mercer street, New York, and may be fitted with an "Ajax Arch," for the transport of demountable rims.

# THE AUTOMOBILE

## Old Dobbin as a Road Destroyer Horse Is Harder on Highway than Car



*Critical examination of roads used for horse-drawn travel and automobile traffic discloses the fact that the calks with which horseshoes are equipped do a vastly amount more damage to the road surface than do the wheels of automobiles. Aside from the fact that horses are unsanitary and uneconomic the recent hot wave demonstrated that they are unable to answer the demands of ordinary city service.*

**O**LD DOBBIN and not the automobile is the chief sinner against good roads, despite prejudiced statements to the contrary. In fact the automobile operated at a legal rate of speed has a tendency to improve soft roads by packing them down and smoothing out minor inequalities, while Dobbin's sharp iron calks tear up the surface and necessitate repairs.

On the ordinary country road, no matter how well-oiled it may be, the chopping action of horses' calks will soon reduce it to its primitive condition, while the passage of motor traffic will benefit it under moderate conditions. It stands to reason that the wide, smooth tires of an automobile will act as a sort of power-roller and the picking of the horseshoes will tend to destroy the surface.



Fig. A.—Showing a dustless stretch of cement block roadway in the Bronx Park  
Fig. B.—Efforts are being made to cover up old, worn-out roads with oil and tar, and after a short space of time the surface is similar to this

Where the roads are macadamized, paved with bitulithic, block or any other surfacing than stone blocks, the action of horses' hoofs is destructive while the rolling of automobiles is not. Where a horse, trotting along at the rate of ten miles an hour has calks on his shoes say 5-8 of an inch long, he picks up soft road surface with every stride and does more



C—Showing a powerful touring car traveling over the cement brick surface at a fair speed without the slightest sign of dust

harm to a straight country road than a racing automobile. Upon an improved road, the damage he does is almost calamitous. His shoes pierce the surface, which is supposed to be waterproof, and break it down so that water can soak through to the foundation. Then when it freezes the water under the surface expands and completes the work of destruction.

The force of freezing water is so powerful that it will burst metal and where it finds a resting place against a heavy body of concrete, for instance, its bursting power is exerted upward and results in a surface humped up and disintegrated in spots.

During periods of warm weather in winter the passage of a horse or an automobile discovers faults in a fine new pavement built the preceding autumn, and in certain districts these faults are laid unreservedly at the door of the automobile.

As this country will spend something over \$1,000,000 a day for road construction during the next year and as the most destructive agent in nullifying this work and making valueless this vast expenditure is the horse, it is important to place the responsibility where it belongs.

Automobiles have come to stay. They represent a condition of progress in the essential of quick transportation. The volume of automobile traffic is going to increase with every year, because the condition of civilization insists that it shall. The automobile is the advance guard of transportation. It has added billions to real estate values; it has made life on the farm more tolerable and increased its holding power upon the young people. It has made for health, pleasure and recreation and now is striding forward as one of the most important factors in business life of whatever character.

It is not going back because it represents progress, and the wheels of advancement as symbolized in the automobile are rolling inexorably forward. The history of the world holds no instance of retrogression in the art of transportation, and it is not reasonable to suppose that any precedent will be set with regard to such a proven blessing as the automobile.

To illustrate the difference between the action of the horse and the car, take for instance a man with a roller and one equipped with a pick. Let each set out to damage a road as much as possible, the one with the roller, using it as vigorously as his muscles will let him and the one with the pick making three holes a minute. At the end of a day covering eight hours of labor, the man with the pick will have destroyed a stretch of roadway ten feet wide and about 200 feet long, while the fellow with the roller will have improved his road materially wherever he worked.

The most usual argument in favor of the horse is that he is indispensable and that as a consequence, his damage to roads, menace to public health, general uneconomic status and his obstruction to progress must be suffered.

It is true that the common fly depends in large measure upon the horse for the means and medium of incubation and it is equally true that the fly is a distinct menace to health entirely aside from being an unmitigated nuisance. The fly carries germs of disease that are transmissible to human beings and even without the addition of filthy germs, his presence in a bedroom, workroom or dining room is as incongruous and disagreeable as is the presence in the crowded subway car of a man who has eaten onions and lim-

burger for breakfast washed down with alcoholic potations.

The fly causes a vast amount of nervous prostration by his presence in the home and fills sickrooms, hospitals and graves.

If the horse could be eliminated altogether the fly would receive a staggering blow, and his total destruction would be rendered only a comparatively simple matter. Another unsanitary feature of the horse is the fact that where he cannot injure such pavements as granite blocks, he can and does cause the groundwork for fetid, disease-breeding dust. The average city block where horse traffic is general is covered daily with a layer of poisonous material. This necessitates constant labor of street cleaners, and in the event of any laxity on their part in the performance of their duties, a hot sun on the following day will create a condition.

Then, too, the horse is wasteful of energy and is inefficient according to modern ideas. Years ago when transportation was still in its swaddling clothes the horse had a mission. For dozens of centuries he represented the idea of speed. But today his mission, especially in large cities, is finished. He has served his purpose and whether we will or not, he must step back.

He cannot compete as the motive power of trucks or hacks or even delivery wagons with the power of the gasoline or the electric motor. He is too slow and costly. If any concrete demonstration of the unfitness of the horse to cope with the terrible stresses of modern life was needed to show that his day is past, the recent terrific heat in New York and practically every large city in the eastern half of the country expressed the condition with exceeding clearness.

It has been learned that during the two weeks through which the country suffered such tortures from the heat recently, seventeen per cent. of all the horses engaged in trucking and delivery work died. That means that one out of every six horses so engaged on July 1, 1911, was dead by July 12.

Every city government in the United States east of the Rocky Mountains was so prostrated by the item of dead horses



in the streets that it had to slight other municipal work to pick up the rotting remains. In New York City horses lay dead in some of the outlying districts for a day or more in the blistering heat.

There was an ice famine to make matters worse and to no small degree the suffering of the city may be properly laid to the inefficiency of the horse. Dobbin could not deliver the usual load of ice at all. He could not begin to give satisfactory service and the sight of the suffering horses panting and straining under the fearful heat was a picture to bring tears to the eyes of any person with human feelings. Patiently the poor animals strove to obey the orders of their masters, but they failed and many a ton of ice melted and ran away during that siege of heat owing to the impossible task of drawing it along the fiery pavements.

A comparatively few motor trucks would have saved much suffering to the populace by more complete and vastly more certain and swift deliveries between ice docks and distributing warehouses. The people could have had hundreds of tons of ice that melted on the streets and the horse could have been saved much unnecessary suffering and much useless slaughter.

Electricity and steam have displaced the horse as motive power in railway work and that fearful blast of heat this month has gone a long way toward completing the emancipation of the horse from heavy trucking and delivery work in the big cities and placing his duties upon the gasoline and electric motors.

The hog has been barred from municipal life in well-ordered communities and so has the cow. The dog and cat have no reason for existence in crowded cities and both are being legislated out into the country or the crematory. The horse alone is allowed to remain side by side with man on account of his alleged usefulness still being sufficient to mankind to countenance his smells, flies, expense and general lack of sanitation.

The progress in transportation along scientific lines, which has presented to humanity the automobile in its present stage, has also presented the solution to the horse problem. And if any additional force was necessary to make the lesson sink deep into the understanding of thinking men, the hot wave certainly had the force to emphasize the situation.

The indictment against the horse is complete in many counts. He is destructive of the roads to a greater gross amount annually in the United States than the sum of the Rivers and Harbors and the Diplomatic appropriations of the United States Government. If half the flies are accountable to horses and if all the flies shorten human life by the span of two years, as the scientists say, the horse is chargeable with shortening the lives of 100,000,000 people, citizens of the United States, by one year each. If the average life is 33 or 34 years in length, it means that 3 per cent. of man's usefulness is paid for the privilege of having horses and flies as incidents of his life.

The automobile is faster, surer, more enduring, more economical, more healthful, actually cheaper in operation and first cost and vastly more satisfactory than the horse. In the matter of accidents, those in which horse-drawn vehicles figure are manifold more numerous than those in which automobiles figure. This statement will probably be challenged and to those who question its uncolored truth, reference is made to reports of street casualties of any city in the United States. In crowded



D—The same car traveling at the same rate of speed as shown in C over a macadamized road. Notice the dust raised

sections of New York City the proportion is about ten to one and the proportion of horse-drawn vehicles is nothing like this ratio.

No flies breed in gasoline and lubricating oil drippings and no streets are covered with noisome matter as the result of automobiles standing along the curbs. Suppose that it is admitted for the sake of argument that the horse is better than the automobile in every way but one, it will be found that the single factor is sufficient to counterbalance all the advantage that the supposition gives to the horse. Take them in order of economy, health, speed, certainty, damage to roads and general efficiency and give the horse all but one of the qualities in greater degree than the automobile and the car must triumph. If the horse makes for health, has more speed and certainty and causes less damage to the roads than the car, the automobile would still displace the horse because it is more economical in the cost of operation. If the horse is more economical and all the other things mentioned, except in the matter of health, the growing regard for human comfort and life would still force the supremacy of the car. But when the situation is carefully viewed and each condition weighed with care, it is found that the car possesses all the prime qualities and the horse none of them in comparison with the automobile.

Out in the country where the land lies open to the purifying and life-giving rays of the sun, the horse may still find a moderate field of usefulness. Knee-deep in the odorous bluegrass he may find a mission, albeit but a temporary one. His colts may neigh and toss their manes in the up-land pastures for a few years and the patient mares may browse in the shaded lowlands where the brook smiles and sparkles its way to the great river. But his day in town is ended. His sun has set and, as inexorably as the progress of Juggernaut, he will be forced away from contact with mankind in the cities.

He has been weighed in the balance and found to be lacking in modern efficiency. He has been convicted of breeding dis-



E—General view of the cement block road adjoining the Pelham Parkway, in which the good even surface will be noticed

F—Cement block roadway as seen walking along it, showing the sides made of cement banking with a block interposed between the banking and the edges of the transverse blocks. No provision for expansion is apparent

G—This illustration shows a roadway that has been treated with an oil preparation for laying the dust, and in which the part usually used by horses is badly cut up

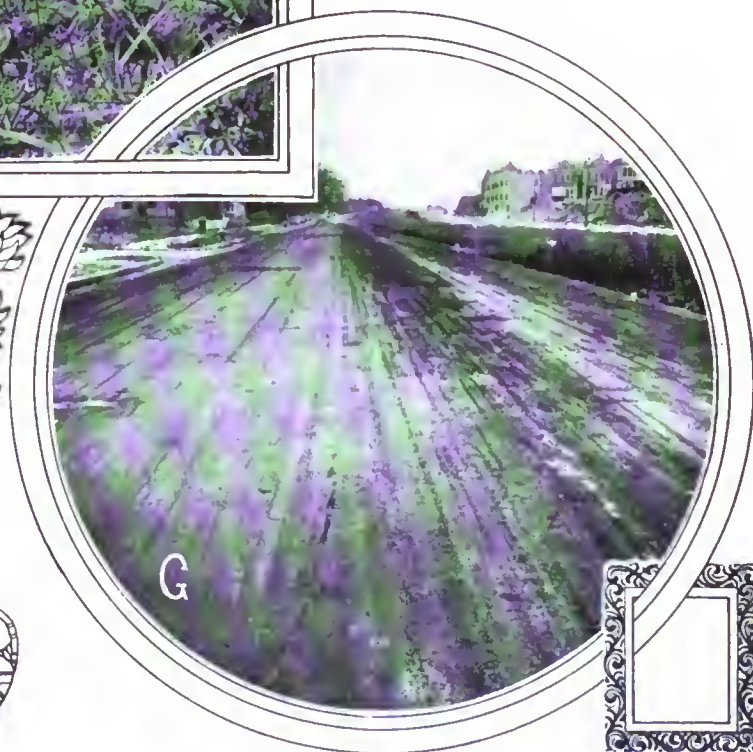
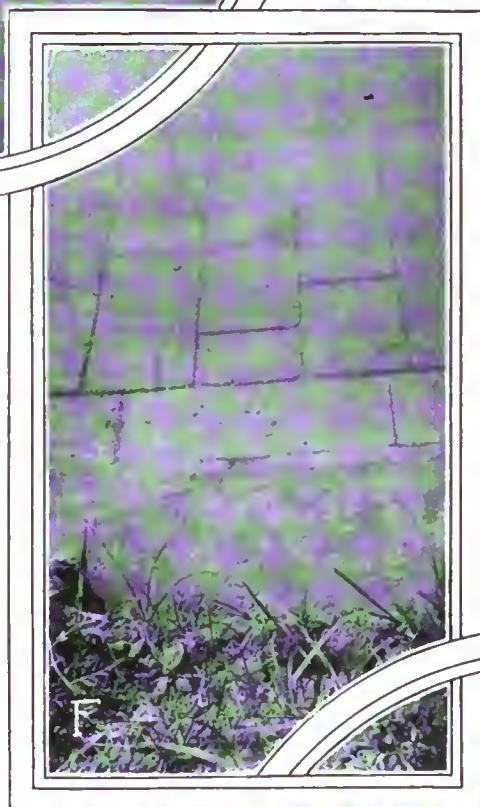

properly drained. It is not proposed here to deal with road-making in the detail form but rather in the abstract. Until the advent of the automobile the point that had to be borne in mind was the tractive effect of horses, and in this respect the efficiency of the draft horse depends upon his foothold. If that be good he can use his entire strength, but if the road surface is hard and slippery the power that could be used in overcoming the resistance of the load will have to be divided in so far as he will only be able to use the power he possesses until the slipping point is attained. The metal of the horseshoe and the hardness of the road surface are diametrically opposed to the hardness of the road surface and the elasticity of tires. Besides, a hard road will tire a horse out much quicker than a road that offers a certain degree of elasticity, or "give." To carry the matter still further, after the elastic limit is reached, as in the case of soft sand, the hoof sinks in and the tractive effort is reduced.

The metamorphosis that has taken place in the last decade has given food for thought to the designers of roads, and with the overwhelming increase of mechanical traction and the use of resilient tires conditions have altered alarmingly, and what previously may have been found to answer will have to be altered to suit present and coming conditions or new ones will have to be devised where the old ones are found wanting.

ease. He had been demonstrated to lack power and economy compared with other mediums and from the first place in man's affections he has sunk to the point where self-preservation demands that man eliminate him from man's crowded dwelling places, and he is now shown to be destructive of roads and consequently a direct obstacle in the path of progress.

Nobody would keep a pair of worn-out shoes for their former association. Such articles, no matter what has been their usefulness in the past, are not decorative and are of no service. They occupy a place that belongs to something useful or beautiful and the only logical thing to do with them is to consign them to the scrap heap. And there, unqualifiedly as far as the city is concerned, belongs the horse.

### The Scientific Side of Road-Building

In the making of roads there are two things that must be paramount in the minds of the builders, and they are that the road surface shall be more or less impervious to moisture and that the under bed shall be



One feature that has been tackled in a somewhat half-hearted manner is the dust nuisance, and it is admitted that in this particular the mountain will have to come to Mahomet rather than that estimable gentleman to the grade. Some cars are less inclined to raise dust than others; nevertheless if the dust is not present one of the greatest drawbacks will be eliminated. The logical method of overcoming dust is to construct roads that are homogeneous as to surface and that can be cleaned either by mechanical means or by the gentle rain from heaven. As an illustration of a road that is dustless and at the same time suitable for the new locomotion, that is shown in Fig. A offers excellent advantages. It is situated in the Bronx Park and has been built by the Park authorities. The road bed is of concrete and the surface is made from cement bricks set in with tar, in a manner similar to that used on the wood block roads. It has been laid now a matter of a little over twelve months and is almost exclusively used by automobile traffic, pleasure and freight alike. Running alongside the Pelham Parkway, it offers a handy means of comparison between the average macadam road and the dustless qualities of the block pavement. Fig. C shows a car traveling over the cement blocks, that have become somewhat shiny with the continual roll of the pneumatic tires and Fig. D represents the same car traveling over the Parkway at precisely the same rate

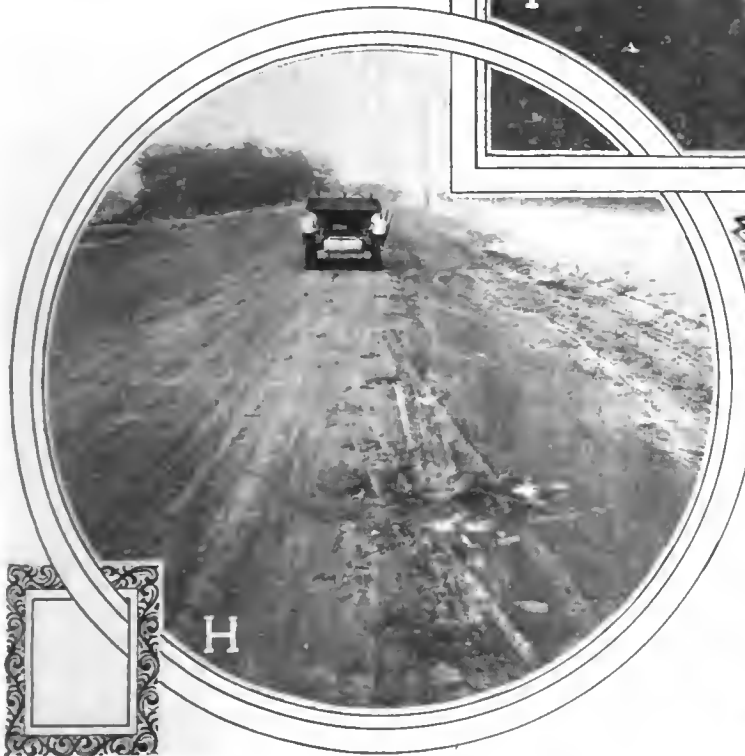
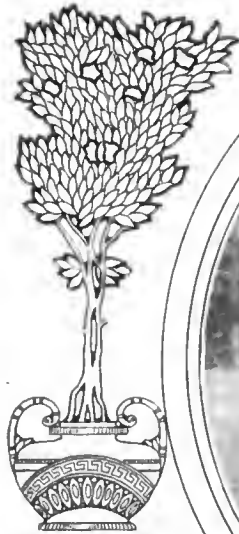

H—Another example of a road surface running parallel to that shown in Fig. G, but with a surface so soft that even a person's footprint makes an impression on the surface. The road shown on the right of the picture is being prepared for a tar surface

I—Part of the White Plains road, showing two types of surface. The light surface is concrete with a cement wash covering and fairly well cambered, whereas the blacker section shows the existing road covered with a tar material and is torn to pieces on a hot day by the calks of the horses' hoofs

J—This is a strip of roadway between two stretches of cement block roadway and it is proposed to replace it in the near future with the cement blocks

of speed. In the first illustration there is not a particle of dust being raised, whereas in the second picture an impenetrable cloud is left in the wake of the car. Reference to Fig. D clearly shows the camber of the new form of road, and it is evident that after a downpour of rain it will be self-draining as far as the surface is concerned. In dealing with this point one thing that has to be borne in mind is the porosity of the substance of which the road surface is made, and it is conceded by authorities that 2 per cent. is the maximum. This is necessary owing to the liability to disintegrate under the action of frost if the adsorption is greater. A general view of the road under consideration can be obtained by referring to Fig. E. The cleanliness of the surface is in a measure due to the absence of horse-drawn traffic.

The method employed in this instance of finishing off the sides is shown at F. The sides of the road are formed by blocks similar to those used in the running surface, with a



K—View taken recently of the existing Boston Post Road about a mile after it leaves the White Plains Road and about to be widened

side banking of cement tapering up to the road surface in the form of a triangle, in the manner illustrated. As was shown recently in *THE AUTOMOBILE*, in making roads of bricks and concrete blocks, there is a necessity for an expansion chamber along the sides to take care of the expansion and contraction due to the changes of atmospheric conditions. This seems to have been overlooked in this instance, but as there are no sidewalks and the road is not bounded by a solid substance, such provision may not have been found necessary. In order to show the cement banking some earth had to be scraped away, but in the ordinary course of events the road edge is similar to that shown in Fig. E.

Fig. G represents a road that had been treated with an oil preparation that has two effects. It lays the dust so long as the surface remains unbroken and the action of pneumatic tires thereon is to bind the upper crust firmly together. The center part of the road shows the section usually used by automobiles while on the left and right hand sides it will be remarked that the oil surface has been broken and this is the section over which the horse's hoof comes in contact. Of course after the calks of the hoofs have started the damage it is not long before the infection spreads to other parts of the road. On the right-hand side of this picture will be noticed two other roads running parallel. The one in the center has been oiled and sprinkled with fine sandy siftings and is very soft and entirely unsuitable for automobile travel. An idea of the softness of

this road can be gleaned from Fig. H. where it will be seen that even the imprint of the pedestrians' feet cuts the road up and if the foot is drawn along it cuts up the surface.

The road on the right-hand side of this picture shows a road in the course of making or rather fixing up. Belonging to the macadam variety with a stony surface bound together in conventional form it is at present being coated with a tar substance. This will tend to make a dustless surface, but upon examination it was found that the surface was not homogeneous at all and a slight kick sufficed to break the surface and mar the smoothness. It is little use covering such a road with a dustless surface if the foundations are not fit to take it and stand the wear and tear. This brings one to the point that it is so much money thrown away to try and convert otherwise unsuitable roads into good ones by placing a covering over them. It will be found necessary in the near future to remake such roads and the money could be used to better advantage in experimental work rather than in covering miles of roadway with what has been found from experience to be a makeshift.

On the White Plains Road just before it strikes the Boston Post Road and the Pelham Parkway there is a stretch of road that compared with that immediately alongside of it in a very favorable manner. The surface is shown in Fig. I and consists of concrete with a cement-washed surface. In the heat it remains solid, while the road seen in the foreground of the



L—In widening the Boston Post Road boulders are being used to form a roadbed and the illustration depicts the heterogeneous class and size of material being employed. It is proposed to widen the road to the posts seen on the right-hand side of the picture

picture is one with a tarred surface and the horses' hoofs tear it up and render it useless. The average road surface that has received little treatment at the hands of the engineers is shown in Fig. J. No amount of fixing will ever bring such a road up to modern requirements until the foundations have been reached and built up anew.

Talking about foundations brings one to what are the best forms of foundation that have given satisfaction in the past. It has been found that foundations should be made of material of approximately the same size and this condition is obtained by crushing the stones that form the bed and passing them through suitably contrived apparatus so that they will pass the four-inch hole, grading to a smaller size the nearer the surface they are required.

Fig. K represents part of the Boston Post Road now in the contractor's hands to be widened and partly rebuilt. The position of the car in the illustration shows how far it is possible to go at the present moment. The road is being considerably widened at the present moment at this point, and it is interesting to see how this is being done. Instead of using the method above described boulders of all sorts and sizes are being dumped in the manner shown in Fig. L and the posts on the right hand side of the picture show the increase in width to which the new road will extend. The saving in labor in the method being employed is, to say the least of it, enormous, and instead of striving

to improve the roads such crude methods as these seem futile.

No matter what material is employed for the road surface there is one vital point that must be borne in mind, and that is that the crust must be so made that it will remain intact or when signs of wear become apparent such repairs must be made in order to reinstate it. The reason for this is obvious. If the upper crust is made waterproof the rain will run off and suitable means must be used to carry this water away in the nature of ground drainage. If this is not the case the substrata will be loosened and cause the road to cave in in parts. The greatest damage inflicted on roads is undoubtedly that caused by the calks of horses' hoofs, as in the endeavor to perform their allotted work it is necessary that these calks should dig into the surface so that the horses can obtain a foothold. The fore feet are usually fitted with shoes with one calk or a toe weight to lengthen the stride, while the hind feet are invariably fitted with three calks. These calks will in time penetrate the surface and the next downpour will materially assist in enlarging the hole.

### The Trend of Events—

POINTS to the building of good roads, remembering that they should be maintained as well as constructed—the old way has to do with the expending of money in the building of roads, and the high disregard of the maintenance of them.





A—End of the lake in the City of Geneva with Mont Blanc in the distance



B—Scene on the Riviera during one of the motor boat races



C—Many beautiful roads skirt the lakes amid snow-capped peaks

## Geneva to Via Trans Alpine

### Tinkering on the Road

There is not a lot to be learned in order that the novice can successfully drive his recent purchase even on an extended tour, provided nothing in a mechanical way happens to upset his calculations. Some things happen that have to be attended to on the spot in order to get along at all, but it is the part of wisdom to leave experiments at the commencement to such time as when the car is in a garage instead of the open road miles from anywhere.

WHEN the novice takes over a new car and starts out for a day's enjoyment his pleasure may be marred by a persistency on the part of one of the spark plugs to foul up. Or at any rate, if it is not the spark plug something, perhaps, is amiss with part of the electrical equipment that is like so much Greek to him. There is a danger in tampering with several parts in the effort to locate the trouble, as the manner in which most novices locate trouble is to take the kit out and choose a tool indiscriminately, turning everything there is to be turned, with a fair chance of finding himself stranded. The road is not the best place to fiddle with the electrical equipment of the car without a previous and thorough understanding, as it takes very little on the part of the operator to render the entire system non-productive of a spark at all the plugs. This being the state of affairs, and supposing that one of the cylinders does not fire, it is most disconcerting to continue to drive with the motor in this condition and damage may result therefrom.

In order to postpone the locating of the trouble, if the ordinary tests have been applied, it would be better under the circumstances to remove the spark plug and drive the car at a moderate rate of speed either to the nearest garage or home, being careful not to run in the wake of another car and sucking up a peck of his dust.

**WARNING GENERALLY GIVEN IN ADVANCE.**—Just before the motor seizes, a pinging sound will be heard. When this warning is given, stop the motor at once and examine it carefully, or serious damage may result from a dried-up water system.

Before the close of next October it will be possible for the touring automobilist to reach the Riviera, via Switzerland, over a 452-mile route, using his car all the way. Even now the road, although several links are not yet completed, is in constant use, the travelers shipping their cars over the uncompleted portions of the route in specially constructed goods wagons attached to electric trains.

THE longest and most pretentious public automobile passenger route in the world, namely, that of 452 1-2 miles, from Evian-les-Bains on the Southern shore of Lake Geneva, Switzerland, to Nice, "Queen of the Riviera," on the Mediterranean Sea, was opened for traffic with appropriate official ceremony on the first day of July. The entire trip over this romantic highway is made by passenger automobiles, with the exception of two or three very short links over the Alpine Road, where electric train service is being used temporarily. Across these spans of metal the motor cars are conveyed in especially constructed goods-wagons to the points of the completed automobile roads, where they are unloaded and put into commission again, taking up the thread of the journey. By October of the present year the portions of the route which are now served by electric train will have been completed, thus making a continuous automobile highway from frost-laden mountain and lake to sunny azure sea. The journey occupies five days, and affords a constant succession of delightful views.

Beginning with "Evian the peerless," the first day's trip takes in the walls of the ancient Château de Ripaille, the Dranse Valley, the Devil's Gorge, the Col des Gats, the entrancing Giffre and Arve Valleys, the gorgeous panorama of Callanches, the very shadow of Mt. Blanc, and the tranquillity of Chamonix. The second day includes the picturesque Col des Arvis, the Annecy and Bourget lakes, the Arley Gorges, the Little St. Bernard and the Vanoise, and through Aix-les-Bains to Chambery. The sun of the third day lights up the Calibier Col, the Lantaret, the majestic Meije, the Barre des Ecrins, a multitude of summits of the Pelvoux and fertile spots of the Guisane Valley, at whose

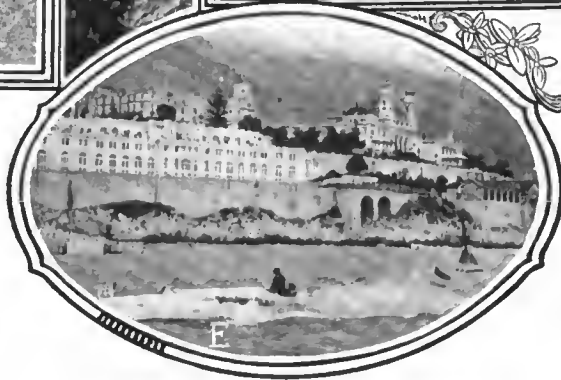

D—A view of the Alps from Mürren, the highest inhabited village in Europe

E—Sheer up from the sea along the Mediterranean rises a crest of hills protecting the seashore towns

F—Typical valley and mountain scene that is met in many parts of Switzerland

# the Riviera Automobile Road

extremity Briançon lies. The fourth day from Briançon to Barcelonnette, the road winds through the surprising Col d' Izard, the Col des Vars, the Queyras Valley and the awe-creating Mount Viso.

Leaving Barcelonnette early on the morning of the fifth day, automobile passengers find themselves admiring the Col d'Allos, the Colle St. Michael, the Verdon and the Var Valleys, Mescla Gorges and the alluring Côte d'Azur. Finally the satiated travelers alight, to find themselves as the day closes at their journey's end, with queenly Nice and her riot of carnival gayety spread before their eyes.

This high altitude highway opens up a surprising panorama to the tourist who has become weary of train travel or pedestrianism and seeks new glimpses of scenes which may be classed as akin to the sights of fairyland. The tariff per passenger is \$38.70, not including hotel accommodations and meals en route, which may be figured at about \$4 per day.

To tourists familiar with the Alpine summits and their relative valleys, this new highway is regarded as being unique, straggling away, as it does, in its serpentine course along the brinks of stupendous precipices, as well as penetrating the wilds of hazardous gorges.

Scintillating glaciers, dense patches of dark green woods, wide stretches of snow-clad flats, verdant fields, mighty mountains, streams leaping from boulders into seemingly bottomless caverns, roaring cataracts, mediæval towns, villages crowned with castles, limpid lakes and, finally, a dash into the semi-tropical zone, dotted with luxuriant gardens. These are some of the advantages enjoyed by the automobilist.

Perhaps as interesting a feature as any other in connection with this tour is the special goods-wagon for the transport of automobiles. The wagon is enclosed, affording the motor car a safe journey.

The owner of the motor car on a private tour may safely ship his machine from Paris to Evian and proceed to Nice, certain that his car is in reliable hands while connections are being made over the temporary electric lines. Likewise, this transportation is extended for the convenience of the automobiles making the daily tour over the romantic Alpine Road.

## Kerosene for Automobiles

*When it is fully realized that the only objection to using the cheaper and less volatile distillates of crude oil lies in the difficulty of their carburetion, it becomes evident that the chief line of improvement of the carbureter lies in their ability to be adapted to these fuels.*

CARBON trouble must be charged in great degree to inferior carburetion, and that this source of trouble is becoming more acute every day is recognized, due to the fact that the non-volatile constituent in the gasoline supply is being increased from time to time at the cost of the more volatile hexane which is being decreased in the same ratio.

Fully 50 per cent. of all the volatile portion of crude oil belongs in the distillates approaching decane, and it can therefore be readily appreciated that the distillers of oil are extremely anxious to have decane liberally represented in automobile gasoline. It is not believed that they consult the builders of carbureters in matters of this sort, nor is there any record of their having called a convention of autoists with a view to being favored with its opinion as to the efficacy of kerosene oil for use in automobiles.

Surprising as it may seem, the inventors of kerosene motors have been put out of business due to the improvements wrought in carbureters and the splendid backing of the distillers of crude oil. Just as fast as carbureters are improved so that they are rendered more capable, the distillers of crude oil add another dash of the less volatile constituents until finally the carburetion problem has arrived at a near approach to the time when automobile gasoline may contain 50 per cent. of kerosene oil.

Since this is the exact amount of kerosene oil present in the whole content, there is no inclination on the part of the distillers of oil to add more—in fact, it would even be a detriment to do so.

THERE is a strip of coast-road along the Gulf of Salerno, in Italy, between Salerno and Sorrento which is not excelled anywhere in the world for perfection.

# When Judgment Whispers Don't

## (Aphorisms Apropos of the Automobile)

*There are so many acts that may be committed with impunity if they are done at the proper time that the thought is suggested that reflection should accompany every undertaking.*

- DON'T adorn the fleeting moments with idleness.
- DON'T work overtime on an undertaking that promises failure.
- DON'T stand in your own light long enough to let your neighbors unhorse you.
- DON'T stand in the light of the man who has no purpose but to treat you fairly.
- DON'T exact "the ounce of flesh" if the surgical operation so represented is likely to defeat the project.
- DON'T become too much attached to "distant verdure" even if it does look the greenest.
- DON'T be persuaded to think that an impracticable idea will work just because some other fellow says it will.
- DON'T finance any impossibility at the suggestion of the beneficiary under the plan.
- DON'T derange the plans of the fellow who promises too much—let him alone.
- DON'T invite mere schemers to join you in your everyday enterprises.
- DON'T strike the blow that will kill the goose that lays the golden egg.
- DON'T listen to the North wind while the South wind robs you of your enchantments.
- DON'T scatter aimlessly the thought which, when properly managed, will count on the side of equity.
- DON'T incorporate into a mechanism the disorders of a severe climate.
- DON'T build an automobile so poorly that you will have to try it upon the dog.
- DON'T burn the midnight oil assiduously for no better purpose than to purchase a necklace for despair.
- DON'T go to a body-making plant for a good automobile—they are fashioned in machine shops.
- DON'T put a poor-looking body upon a well-made chassis—it is like hiding your light under a bushel.
- DON'T neglect business for the purpose of purchasing an inferior make of automobile—you will suffer a double loss in the interim.
- DON'T place your crest on the panel of an inferior product—you might be taken at your own estimate.
- DON'T try to turn the course of logic and of truth—these streams flow in a bed that was fashioned by the hands of time.
- DON'T join the squadron of the discontented—act with wisdom and your path will lie in the opposite direction.
- DON'T help to fill the storehouse of poor ideas, or lend financial support to projects that have no stamina.
- DON'T pay the price of an uncanny idea offered you by a canny man.
- DON'T forget that curses, like chickens, come home to roost—uncalled-for abuse of the repairman may result in a "brood."
- DON'T order a green color for the body of your automobile if you reflect the same color in your actions. The two shades may not match.
- DON'T rely upon a superficial examination of a car that is to cost you coin of the realm.

- DON'T be afraid to talk up in meeting—the agent, perhaps, is a trifle deaf.
- DON'T misjudge the power of action—if you act as if you have a sense of proper discrimination the dealer will take his cue accordingly.
- DON'T risk the idea that supreme happiness comes with the possession of a car—delights desert the owner of a poor affair.
- DON'T purchase a manicure set in substitution for tools for the tool-kit of your automobile.
- DON'T despair if you have to apply surgery to the car of your choice—cutting out some of the bad ideas might have the effect of giving the good ones a better opportunity to perform their proper functions.
- DON'T serve as the "evidence" if a fraud is being perpetrated nor play the principal part.
- DON'T live in anticipation of delights to come if you give your money to the second-hand man first.
- DON'T discourse with the seller at considerable length about what you are to get for your money—let him tell his part of the story in writing.
- DON'T waste too much time on a highly accomplished salesman—your need is in the shape of a highly accomplished automobile.

### Stopping the Car Quickly

*Although the careful driver rarely allows himself to be caught in such a position that the safety of the car and its occupants depends on the ability of the brakes to immediately arrest forward progress, it sometimes happens that a quick stop is highly desirable. The sudden stoppage of "the car ahead" is a case in point.*

IT occasionally happens that skidding occurs when the autoist is endeavoring to bring the car to a stop within a limited space. No matter what the condition of the roads, whether wet or dry, it is at times difficult to pull up quickly if another vehicle has suddenly stopped a short distance ahead of the car. Setting the brakes introduces side slip at the rear, and while this tendency can be checked by means of the steering gear the forward skid will continue in many cases. The fault is, of course, on the part of the autoist in having approached the other vehicle at too great a speed consistent with the state of the road and with regard to the efficiency of his brakes. To obtain the maximum retarding effect under such circumstances, the brakes should be applied and released alternately with a quick vibratory motion of the foot, a powerful braking influence being thus brought to bear on the wheels, and the intermittent periods when they are free to roll enabling them to maintain their grip on the road.

### Willing to Give Him Another Chance

An Irishman who was sent to clean the windows of the 27th story of a sky-scraper lost his hold, violated the speed limit in falling to the pavement below, and a mob quickly collected, when one spectator said: "Poor Pat is no more!"

Pat (opening his eyes at the sound of voices): "Sure and Oi'm not dead!"

Convenient Cop: "Wait a minute; here comes a big limousine!"

## Items from Foreign Lands

*Interesting extracts, mainly from the United States Consular Reports, in which the status of the automobile in foreign parts is tersely set forth, and the prospects of extending the American market are called to the attention of those interested.*

**H**ONGKONG and Canton are two cities in China which are entirely unfit for motor car traffic, owing to the narrow streets. In some instances the roads are little better than mere footpaths, being from 4 feet to 6 feet wide. Sharp turns abound here and there, while at intervals in the road the automobilist encounters steep flights of stairs. Shanghai offers more encouragement to the motor car driver, the streets being quite wide, a fact which may, in a measure, account for 400 automobiles being found in the city.

The "foreign devil" who invades the Celestial Empire is not justified in feeling too sanguine as to his ability to penetrate into every section in an automobile. He will find himself absolutely barred from certain walled cities. He may drive to the very gates with his motor car, but here he will find himself facing a cluster of very disagreeable obstacles, including the police, mobs of coolies, swarms of "the people" and bands of residents who, with arms raised in the attitude of horror and hostility, threaten the automobilist who dares to make an attempt to pass the gates. Popular prejudice cries out angrily against foreign invasion.

The Swiss are going in for very heavy motor trucks for use in the Tyrolese Alps. These vehicles are built to carry very

heavy loads up the steepest mountain grades. To this end the 40-horsepower engine is being utilized. Horse-drawn vehicles have disappeared almost entirely from these mountain highways.

Halifax has just acquired its first motor truck. Its appearance on the street aroused a good deal of interest. It has a capacity for carrying three tons burden. Oil barrels will constitute its loads, for the time being, at least. The truck will run between Fairview and Dartmouth. The body of the truck was built in Halifax. The truck itself was made in this country.

Calgary, British Columbia, has kept pace with the times, in a motoring sense, the latest movement in that far-away section being found in the organization of the Calgary Automobile Club. The membership in the beginning was twenty-one. The fee for joining is \$10. The literature of the club sets forth its objects, which include the making of good roads, the erection of sign-boards, the building of club houses, and legislation against reckless drivers. There are 300 automobiles in the city.

Italy's King is one of the most accomplished as well as enthusiastic automobilists in Europe. Not alone does he possess some of the finest motor cars made, but he can drive a car as handily as the experienced chauffeur. Besides, His Majesty is capable of repairing his own automobile, he being a practical mechanic.

Automobilists riding through Upper Studley, a community near Trowbridge, England, are apt to have their attention called to an unique pile which suggests that it might well be regarded as a monument to the (at least partial) passing of the horse in that vicinity. It is nothing less than a heap of cast-off horseshoes, weighing 150 tons, standing 17 feet high and measuring 10 feet on each side. The value of the iron is at least \$2,000. The owner spent two years in collecting the shoes for a curiosity.

## Marmon "Thirty-Two" in Detail

### Apart from Refinements Will Remain Unchanged

*In presenting the latest type of Marmon it will be noted that there has not been any attempt on the part of the designers to make radical changes in design, and it is rather a matter of sticking to adopted lines and tried plans. One size power plant is employed for the several types of body work and the detail parts show accessibility and consideration for the user.*

**T**HE plant of the Nordyke & Marmon Co. is located at Indianapolis. By increasing the size of the factory from time to time another industry has been added to its former field of endeavor, the automobile end now being as large as the milling machinery business which forms the other half and which has been established for over half a century.

It is the aim of the builders of the Marmon to make as much as possible of its automobile product in the one factory, and,

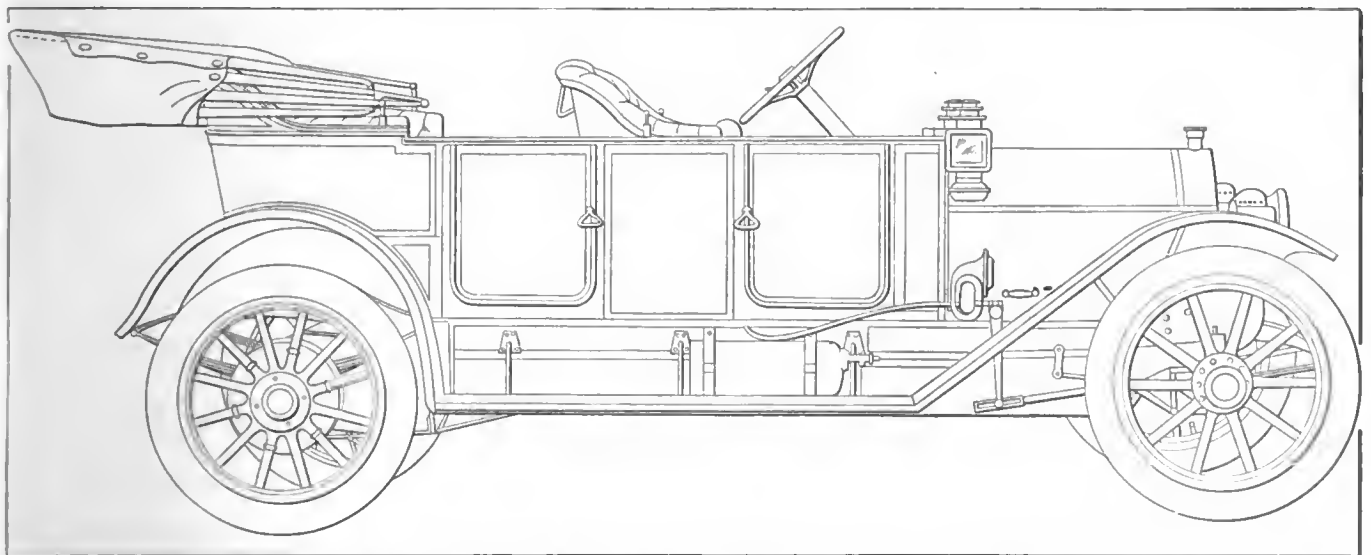

Fig. 1—Marmon "Thirty-two" with five-passenger fore-door touring body of straight-line design

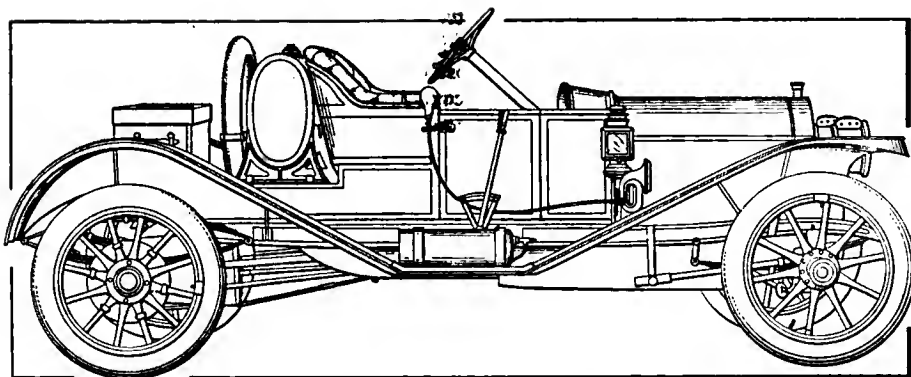

Fig. 2—Showing the Marmon Roadster, with oval gasoline tank and provision for storing the spare tire

with the exception of smaller accessories such as ignition apparatus and the like, the car is built from the ground up under one roof. According to those in authority the yearly model will soon sink into oblivion, and such improvements as may be found necessary or desirable for the betterment of the product or the convenience of the users will be incorporated in the cars as soon as the series allows. It is the intention of the Marmon company to increase the output for the coming season, and the previous year's "Thirty-two" will remain unchanged in most respects.

The comfortable-looking five-passenger touring body, with closed front shown in Fig. 1, indicates that the question of weight has been carefully studied, the passengers on the rear seat being bestowed within the space allowed for the wheel base, and as there is no overhang of the body the riding qualities are thereby enhanced. The mud guards are fitted with inside valances, thus protecting the body and passengers on dusty and muddy roads.

The Roadster model shown in Fig. 2 bespeaks forethought in one vital particular. The spare tire is always a matter that, unless proper provision is made for it in the design of the body, becomes an eyesore, and the method employed in the case in point places it in an accessible position, yet out of the way, so that it is less likely to be damaged by continual handling and the action of the elements. The gasoline tank, placed immediately behind the driver's seat, is oval in shape, with sufficient head allowance to dispense with pressure feed. The gear lever is placed inside the front door, with the brake lever placed on the outside, thereby reducing the width of the body, which is fitted with a cowl in the front for better protection of the occupants. The equipment of the Roadster includes a trunk placed

on the rear with suitable covering for protection of the contents. It is surprising how dust will find its way through the smallest crevice unless such a covering is provided.

The general appearance of the front of the touring car can be seen in Fig. 3, showing the headlights carried on offset brackets with a tie bar so that no interference will upset the efficiency of the cooling qualities of the radiator. The bodies are made in the factory, and are somewhat unusual in that instead of being built up from different woods, with sheet metal panels, the base together with the door frames and doors are made from cast aluminum.

The general aspect of the chassis can be gleaned from Figs. 4 and 5, showing the right side and plan views respectively. The chassis suspension as seen in Fig. 4 is taken care of by semi-elliptic springs on the front and full elliptic springs on the rear, the lower half of the latter being clamped to a bracket which is free to oscillate around the axis of the axle casing. The rear springs are 40 inches long and 2 inches wide. The front springs are 35 inches long and the same width as the rear springs, but instead of being placed on the axle equidistant from the front and rear they are 15 inches from the front and 20 inches from the rear, which allows of carrying the radiator on the plane of the axle.

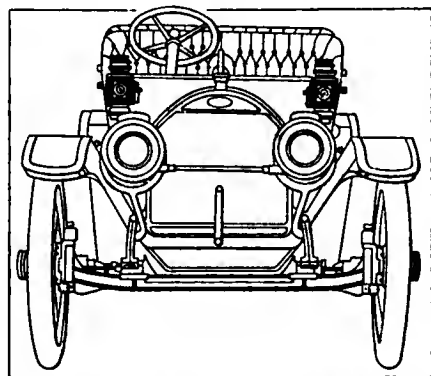

Fig. 3—Front view of the five-passenger touring car, showing the offset lamp brackets

### Three-Point Suspension Supports the Motor

The plan view of the chassis (Fig. 5) discloses the disposition of the various working parts and the tapering of the frame from a broad section beneath the dash toward the front and rear together with the general arrangement of the brake levers and the radii rods.

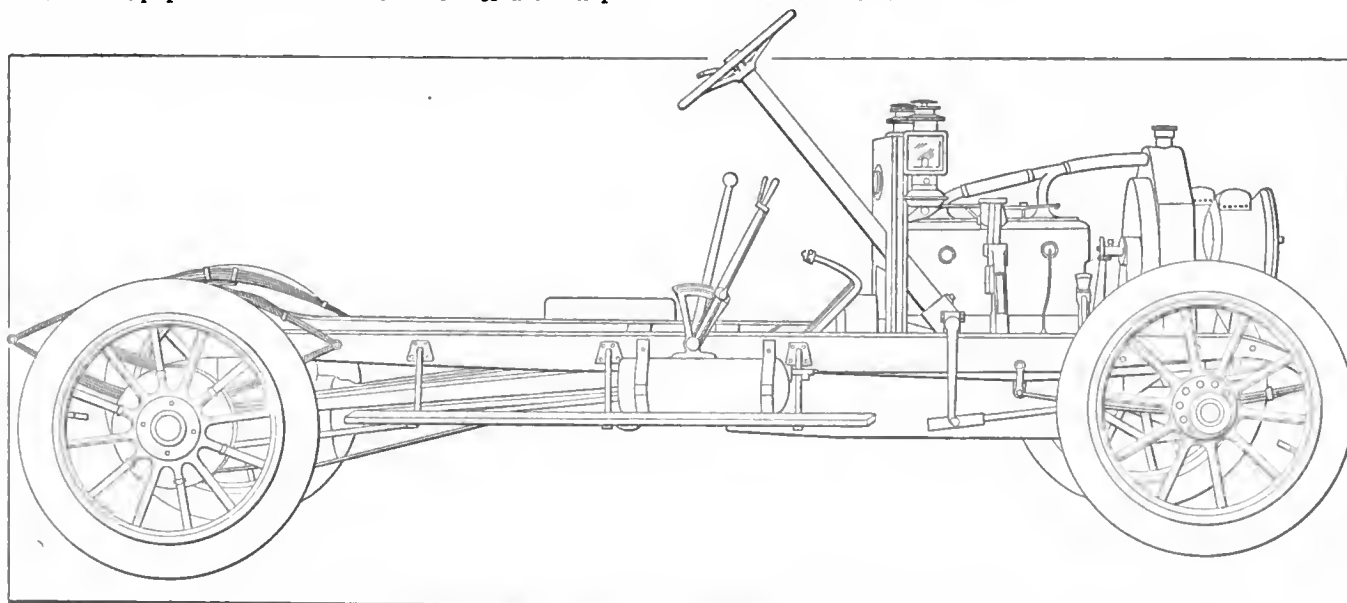

Fig. 4—Chassis of the Marmon "Thirty-two," showing method of suspension—semi-elliptic springs on front and full elliptic on rear



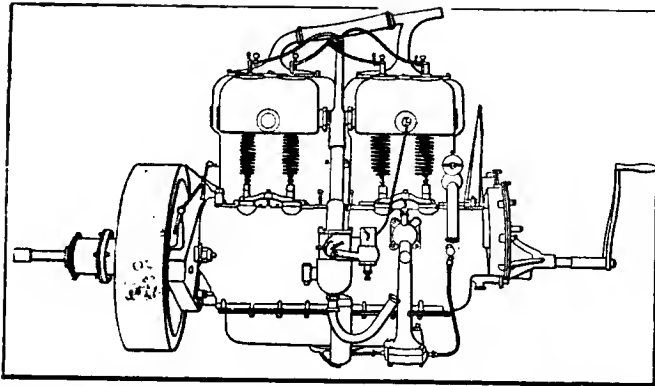

Fig. 6—Intake side of the motor of the Marmon "32," showing the low-hung carbureter

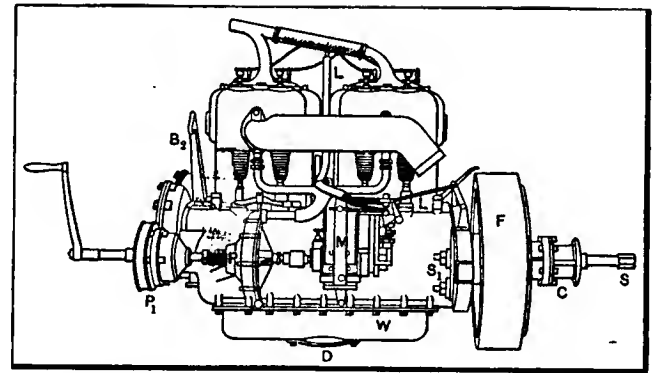

Fig. 7—Exhaust side of the motor, showing method of driving the pump and magneto

The four-cylinder motor is of the four-cycle type, with the T-shaped cylinders cast in pairs. The bore is 4½ inches and the stroke 5 inches. The cylinders are cast from a special grade of iron, with the exhaust and intake valves on opposite sides. The crank chamber is of the barrel type with a separate bottom

serving as an oil reservoir, both of which are aluminum castings. One of the features of the Marmon motor is the intake manifold. One pipe is taken from the carbureter and is attached to the cylinders on the side between the two cylinders by means of locking rings. This virtually transforms the intake passages of the cylinders into a hot-water jacketed manifold, permitting good carburetion at slow speeds as it eliminates condensation.

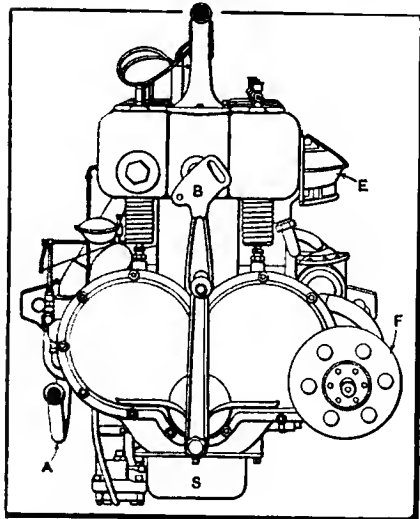

Fig. 8—Front of the motor, showing the form of valve tappets used and method of securing the valve springs

The front end of the crank case is extended, affording a bearing for the starting crankshaft. The motor is mounted with a three-point support, the forward end attached to a trunnion resting on the channel cross-member and the rear end is carried by a pressed-steel support, S, in Fig. 7, the ends of which are attached to the main chassis frame. In order to obtain a straight line drive the motor is inclined slightly towards the rear. The crankshaft is a steel forging of ample section (Fig. 9), with three main bearings.

Fig. 6 shows the right-hand side view of the motor and the low-hung carbureter. A Schebler carbureter of the water-jacketed type is employed to provide the mixture, the water being furnished for the heating through a copper pipe from the front pair of cylinders, a cock being placed in circuit to shut off the supply if desired. The oil pump can be seen in the illustration driven by gearing off the right-hand camshaft; a breather being fitted at the front end of the crank chamber to pour the oil into the base as may be desired. Fig. 7 shows the method employed in driving the pump and magneto. On an extension of the camshaft in front of the half-time gear

case there is a pulley which through the intermediary of a flat leather belt drives the fan placed behind the radiator and attached on the bracket B<sub>2</sub>. The pump shaft has an Oldham coupling to facilitate dismantling, and the magneto M is driven by an extension of the pump shaft which also has an Oldham coupling. In order to remove the magneto M all that is necessary is to loosen a thumb nut that holds a spring steel band in position and the magneto can be lifted off the shelf on which it rests. The valve tappets have screw and locknut adjustments and are fitted with hardened steel rollers riding on the cams. The tappet guides, turned out of white brass and held in place by a pair of crow feet are fitted with dust caps over the tops. The form of tappet used may be seen from Fig. 16. The tappet T accommodates the screw A; at the other extremity there is a roller R which has a bronze bushing mounted on a hardened steel pin. The guide is slotted to accommodate the flat sides of the tappet foot and thus prevent it from turning. The valves V and V<sub>1</sub>, for the intake and exhaust respectively, are interchangeable and have taper seats. The method of securing the valve springs can be seen from the same illustration. A counter-bored washer C fits over the valve stem and a small steel washer made in two halves fits into the grooves in the stem. The counter-bored washer fits over the split washer, holding the spring securely.

The motor is cooled by means of a cellular radiator supported on a trunnion. A dual system of ignition is employed using a high-tension magneto and a single coil, the latter being placed on the dash. The commutator in the magneto is utilized in distributing the current to the spark plugs, which are placed over the intake valves, in the event that the battery is used either for starting or emergency. The water pump is of the centrifugal type, of ample dimensions and has a tap placed at the lowest point of the circulation to drain off all water when this is found desirable.

The piston rings, which are of the triple expansion type, are

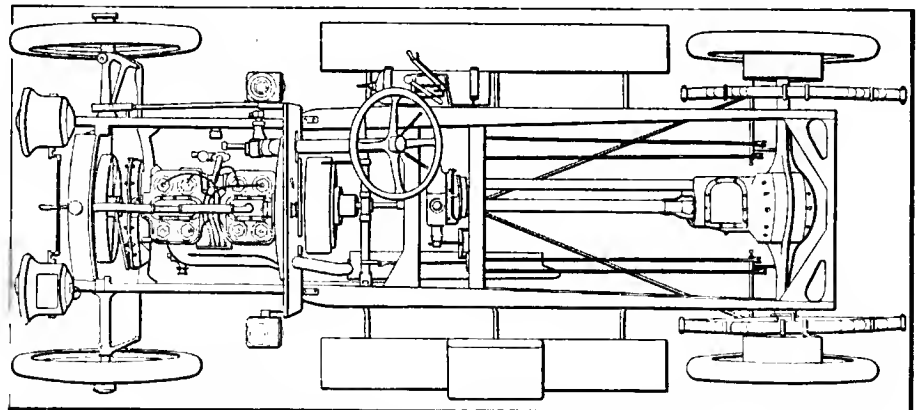

Fig. 5—Plan view of chassis, showing the taper frame and the disposition of the working parts

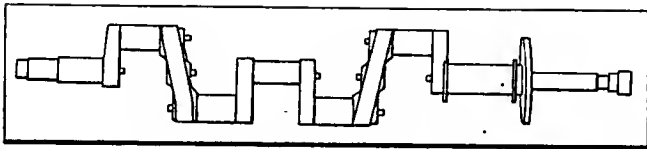

Fig. 9—Crankshaft of the Marmon is a single steel forging of large dimensions

shown in Fig. 11. They consist of two narrow rings placed over a wider ring and pinned to prevent oscillation. The wide rings R<sub>1</sub> can be seen dismantled from the two narrow rings R<sub>2</sub> and R<sub>3</sub>, R representing the assembled unit. The method of slotting the narrow rings in order to accommodate the pins can also be seen.

The part section of the motor shown in Fig. 10 shows the system of oiling used. The gear pump P, driven off the half-time shaft, draws oil through the lead A from the well in the base chamber through a screen and forces it through the pipe B to three main leads into the hollow crankshaft by means of the pipes M, C, D and K. The oil is then forced under the pressure exerted by the pump into the big end bearings of the connecting rods and up small copper pipes G and G<sub>1</sub> to the wrist-pin bearings. The pressure of the oil can be regulated by a conveniently situated valve alongside the pump P, and the gauge G<sub>2</sub> placed on the dashboard shows the pressure of the oil passing through the system. The pump is placed outside the crank-chamber and is readily removed. In order to register the amount of oil in the base there is fitted a float and level gauge O provided with a glass window. The big ends of the connecting rods dip into troughs and lubricate the cylinders and other working parts not lubricated under pressure by splash. The breather B<sub>1</sub> is fitted with a hinged cover and the gases that escape past the pistons are given free egress through the orifice O<sub>1</sub>.

A cone clutch engaging in the flywheel is employed to transmit the power from the crankshaft to the transmission, which is located in the same housing with the rear axle and differential. The male member of the clutch is of cast aluminum, having an asbestos fabric covering riveted thereto, with relieving springs under the fabric to take the shocks of starting. The engagement is effected by means of a spiral spring located inside the chamber C in Fig. 7, and the thrust is taken by a ball bearing. The rear axle transmission unit is shown in Fig. 12. The propeller shaft is housed in the tube, the forward end of which is carried in a large ball-and-socket support within a dust and oil-tight aluminum housing on a cross member of the frame. Within the ball joint B<sub>2</sub> is a universal coupling connecting with the drive shaft, and a second universal joint is placed forward within the clutch. The torque is taken by the main tube and the ball-and-socket joint. The pull-and-push braces R and R<sub>1</sub> from the axle ends to the forward end of the tube hold the axle securely in right angle position, and truss rods with adjustments

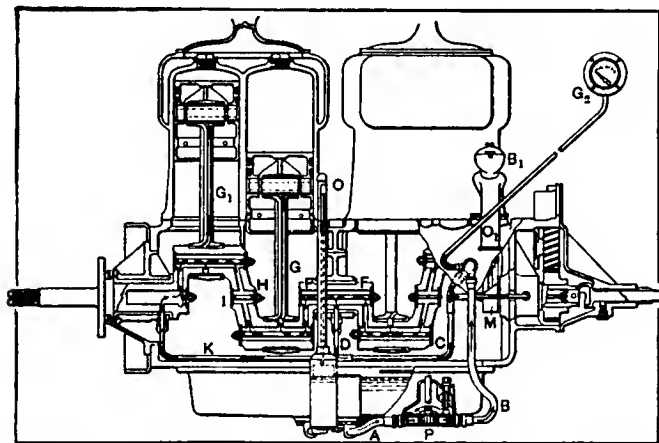

Fig. 10—Part section of the motor, showing the system of lubrication

pass from the center of the axle underneath the gear box to the forward end of the tube casing and under the axle proper, adding strength and rigidity to the structure. The box T contains the gear set, which provides three forward speeds and reverse. The oval casing T<sub>2</sub> encloses the gear-operating rods which terminate in the front at A<sub>1</sub>. A cover C is provided over the transmission in order to replenish the lubricant therein from time to time. The rear end of the transmission casing is bolted on to the pressed steel axle casing at B<sub>1</sub>. The axle as presented shows the wheels removed and discloses the two internal expanding brakes that operate inside the same drum. The rear end of the differential housing is formed by an aluminum cover which when removed gives ready access to the working parts.

The disassembled parts of the transmission and the differential are shown in Fig. 13. The square sliding shaft with the pinions attached is shown at P and the shifting arms A and A<sub>1</sub> may also be seen. The layshaft running on ball bearings is shown at S. A steel plate with integral bearing supports C and C<sub>1</sub> for the journals of the differential, which also carries the adjustable pinion bearing and the rear bearings of the transmission gear set, is bolted within to the forward opening of the axle housing, and it is the removal of this plate through the rear opening which permits the easy and quick removal of the transmission.

The axle is of the floating type, the drive shafts are of large dimensions and are made of chrome nickel steel with square inner ends S<sub>1</sub>, Fig. 12, which slip into the differential and the integral flanges at the outer ends, riveted to flanges bolted to the outside of the wheels. The rear wheels run on a single ball bearing of ample dimensions. The brakes are placed parallel inside the rear drums on the rear wheels.

A side view of one of the sets of brakes seen with the wheel removed is shown in Fig. 15. The brakes are of the internal expanding type and operate within a drum 14 inches in diameter, the width of each of the shoes being 2 inches. The shoes are faced with asbestos fabric and the ends of the shoes are fitted with slots that correspond with the spacers D, D<sub>1</sub> and D<sub>2</sub>, which with the aid of springs S and S<sub>1</sub> give to the whole a floating ring construction and prevent chattering and rubbing when the brakes are not in operation.

The adjustment is effected by means of altering the position of the operating cam C by means of a worm and sector placed under the front floor boards, a separate adjustment being provided for the foot and emergency brakes. The brake drums are of pressed steel, being secured to the wheel hubs by means of bolts and clips to alternate wheel spokes.

The front axle is shown in some detail in Fig. 14, from which it can be seen that it is an I section drop forging as indicated at A and A<sub>1</sub>, the spring perches P and P<sub>1</sub> being forged integral therewith. The steering yoke S and the spindle P<sub>2</sub> are also drop forgings, and the point of attachment of the yoke to the axle is strengthened by means of the web W<sub>1</sub>. Ball thrusts are fitted inside the head to take the weight of the load and a dust cover C is provided, into which is screwed a grease cup for lubricating purposes. The tie rod is situated behind the axle and is attached to the arms A<sub>2</sub> by means of yoke forgings that are threaded and screwed inside the rod; a split clamp is fitted and held firm by means of a bolt.

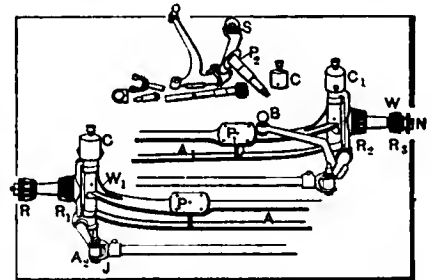

Fig. 14—Showing the front axle assembly and steering knuckles

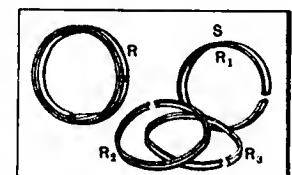

Fig. 11—Showing the triple-expansion piston rings

The pins that pass through the yoke and attach it to the lever arm are of hardened steel working in bronze bushings and fitted with oil cups. The wheels are carried on roller bearings R, R<sub>1</sub>, R<sub>2</sub> and R<sub>3</sub>, and are attached to the spindle by means of a nut N and a washer.

The wheelbase of the standard model is 120 inches and the tread is 56 1-2 inches. The clearance allowance has been well thought out and has been fixed at 10 inches, which should be sufficient for the average road over which automobiles are intended to travel with safety. The road wheels are of the artillery type, 34 inches in diameter; but 32-inch wheels can be had if the purchaser so desires. Quick detachable rims are fitted to all wheels and these are shod with 34x4-inch tires. The weight of the car is 2500 pounds with the tanks filled but without passengers.

### Oiled Roads in Canada

*Dominion highway authorities are satisfied that crude oil sprinkled on the roads has demonstrated its value as a dust preventer. The city of Toronto has discarded the use of water entirely in sprinkling certain streets, and has substituted a light oil with an asphaltic base.*

THE highway authorities in Ontario Province, Canada, have come to the conclusion that crude oil sprinkled on macadam roads is proving itself a very satisfactory material for keeping down dust. They have also declared that by this means the damage done to adjacent fields of grain is greatly diminished.

Toronto city makes use of oil to a wide extent, having discarded water altogether for sprinkling certain streets. The authorities say that they prefer oils with an asphaltic rather than a petroleum base. The oil is sprinkled from a cart—scattered and not allowed to collect in pools—the cart being driven at a

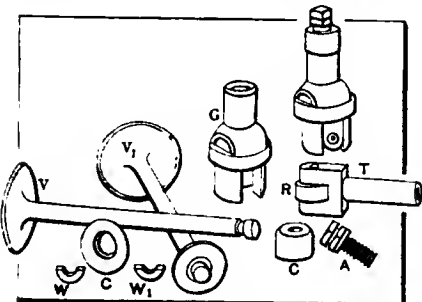

Fig. 16—Assembly of the Marmon valves and tappets

fairly rapid pace. A man sometimes follows the cart with a broom to brush away any pools that may collect. A mixture of crude oil and limestone dust makes a toughened skin over the roadway, preventing dust and preserving the metal surface. Two or three applications of oil within a fortnight early in the Summer and then four or six weeks apart will suffice. About 1,500 gallons per mile will make the first three applications on Toronto streets, 24 feet wide. These oiled highways are the joy of automobilists.

**CARE OF SPRING SHACKLES.**—Spring shackles cannot fulfil all the conditions required in connection with a fast-running vehicle on a rough road; they may mitigate many of them, and if there is not great care exercised in the design and application, they may very easily greatly exaggerate evils they were intended to cure or prevent. The ends of the main springs are the points of connection with the chassis frame, and all the shocks which pass the tire and the main spring are transmitted through these points.

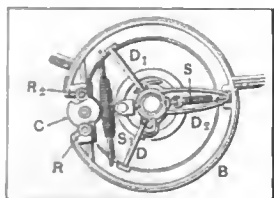

Fig. 15—End view of the internal expanding brakes

The wearing away of these parts is inevitable, and cannot, under any conceivable circumstances, be avoided. The arrangements made for lubrication, etc., greatly mitigate the wear, but it is taking place in a greater or less degree all the time the car is in use. The wearing away of

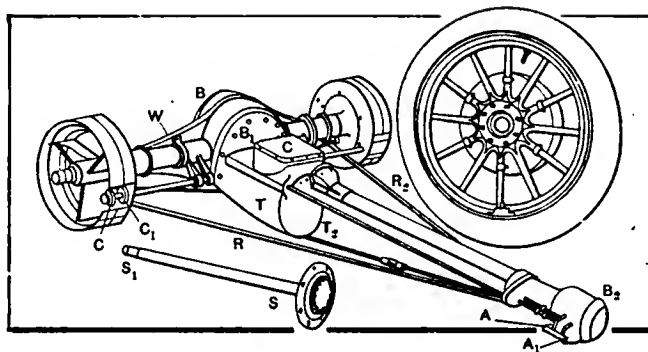

Fig. 12—Rear axle transmission unit, with wheels removed and showing the internal expanding brakes

the bolts and shackles is the result of friction concentrated frequently on small surfaces. The load over the springs is responsible for the pressure and the speed at which the car is being driven for the rubbing friction; the smoother the rubbing surfaces the smoother the working and the longer the time which they resist wear.

### “Soft” or “Nervous” Motors

*A well-known engineer states that the discussion of motors coming under the above popular classification resolves itself down to a question of torque, and that under given circumstances resemble each other strongly.*

THE distinction between “soft” and “nervous” motors, says A. Contet, is devoid of genuine merit and is dictated mostly by commercial considerations. A “nervous” motor has all the characteristics of a “soft” motor when overloaded. The question is one of torque at the various motor speeds. The torque of the short-stroke motor (or 110 by 120 millimeters) of the heretofore ruling design is generally superior below 1,500 revolutions per minute, while that of the long-stroke motor, developing the same power with 85 millimeters bore and 160 millimeters stroke, is superior above 1,500 revolutions per minute. With regard to the bearings of the long-stroke motor, Contet maintains that their rapid wear is simply due to the erroneous practice of using only two bearings for the shaft of a four-cylinder motor, which compels the use of very large diameters and consequently rapid wear of connecting rod bushings, due to the high linear speed. He considers that every “pushed” or “nervous” motor should necessarily be equipped with five crankshaft bearings for four cylinders, so that crackpin diameters may be reduced to their minimum, and that these bearings furthermore should be ball-bearing, so as to give room for widening the connecting rod knuckles and diminishing the pressures per square inch. By this means the pushed motor may be made just as durable in all its parts as the customary type.

Just at the present moment there is an attitude of uncertainty among the automobilists of Canada, because of the changes which are apt to be brought about in the event of new tariff regulations going into effect. It is estimated that the duty on motor cars would be reduced at least 5 per cent.

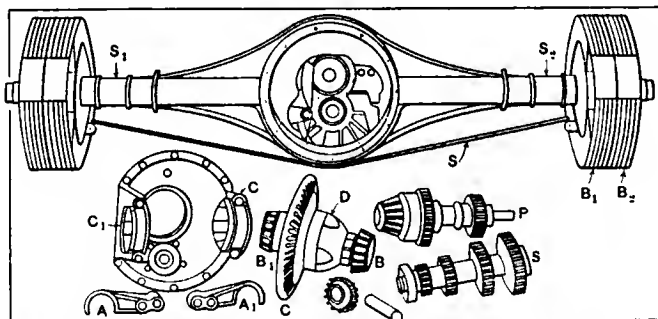

Fig. 13—Showing the Marmon transmission and differential disassembled

## Power Plant for a Country House

*A small plant may be installed in a country house which may be used by the owner for a variety of purposes and, which will in time, be found to more than pay for itself by cutting down repair and lighting bills as well as in convenience.*

THE man who lives out of town all year is bound to find time, especially in the winter, when he would be able to put in some useful work on his automobile if his garage were heated or illuminated properly. There are so many things to be done about a country house for which a power plant of some sort is a necessity that it is very easy to secure a central plant which will take care not only of the garage and its appurtenances, but also of much of the other work, such as pumping, lighting and churning. The plant installed will, of course, be more or less elaborate according to the necessities of the particular case in point.

A small shed may be built in connection with the garage in which the boiler and engine may be installed. As illustrated in the cut, the engine is on the same base as the boiler and thus occupies very little floor space; an engine producing four horsepower, with the boiler, taking up very little room. Adequate clearance must be provided in installing the boiler to allow of easy stoking of the fire in the boiler.

From this engine may be driven a dynamo which will be sufficient to not only light the garage but the house as well. The engine may be used whenever it is desired, thus making for greater economy and a reduction of lighting bills. Besides doing the lighting, a belt may be carried into the garage which will run a main shaft, from which may be driven a small engine lathe or any other tools required, such as drill presses, etc.

In the Winter time it would be a simple matter to run a steam pipe into the garage from the shed, thus providing a simple and safe method of heating the garage under all conditions of temperature; and work which would otherwise have to be held over until more suitable weather conditions prevailed may be carried on in the most severe parts of the year.

The greatest advantages of a plant of this type over taking the power from a service line is that it may be used for anything the owner may desire, and that one will be able, with the same apparatus, to do all the heating as well as the other work at the very time it is desired. The power does not have to be paid for when it is not in use, as is often the case when taken from a service line, and it is not cut off at a certain time at

night because a full moon happens to be announced by the local almanac. With a garage fully equipped with lathes, drill presses, etc., the cost of upkeep of the automobile would be reduced to a minimum. Valve grinding and all the other operations of repair and adjustment, instead of being done outside, may be made by the mechanic or chauffeur at home with much greater dispatch and under the supervision of the owner of the car. Paying for unnecessary repairs of parts will be avoided.

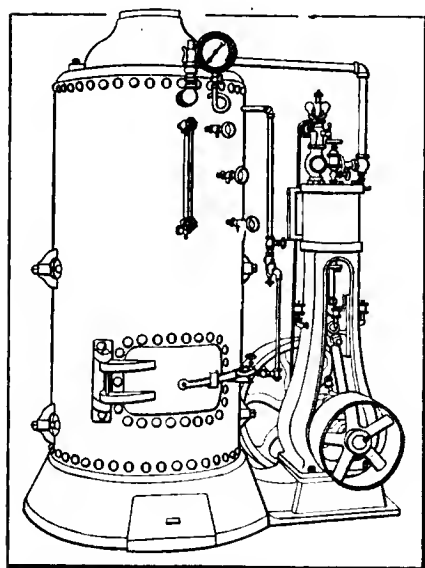

Illustrating a small steam engine and boiler situated on the same base, presenting a very compact and efficient plant

Another use to which the power plant may be put is in driving the water pump. The gas-engine water pump has been found to be very much of a nuisance owing to the very unpleasant noise which generally accompanies its work. A water pump which will be very silent may be driven by belting off the engine.

## As to Road Building

*Being a set of meditations on the nature of good roads, some conditions of their construction and an unusual way of looking at the problem of building them. Contending that history repeats itself, some principles will have to be followed in order to solve the question facing our time at the minimum expense of time and money.*

DURING a recent meeting held in the South relative of the Good Roads movement, one of the speakers made the appalling statement that had such a meeting been possible half a century ago the Civil War would not have been necessary.

Knowing but this one passage of the speech in question, it is of course impossible to see just what consideration prompted the utterance quoted; nor is this the place to debate as to whether the statement was a well-founded one or not. But there is hardly a doubt that, had transportation facilities been different from what they were at the time of the war, history would have been written differently.

Since necessity works in history the same as it is active in the functions of an engine, it must be assumed that the development of history, as brought about by the Civil War, was a necessary one, and perhaps a beneficial one, despite the fact that the best of America's manhood was sacrificed thereby and evolution thrown back for fully a generation.

Coming back to the subject of good roads, it will have to be granted that the best roads in existence to-day are the Roman roads on one hand, and some constructions of later periods on the other, among which the Napoleonic roads deserve special mention. For the success of the Roman and the first French empire these good roads were a *sine qua non*, and it remains to explain the possibility of such enormous engineering feats at times when there were less humans available than at present.

The answer is that the cost of constructing these roads was comparatively insignificant, since the roads were built by either soldiers who were paid little in addition to what they had an opportunity of taking from the enemy, or by slaves whose support was but the cost of feeding them, food also being acquired without any expense in most cases. It was by the cheapness of labor that the construction of really good roads was made possible, and this state of affairs more than balanced the lack of powerful appliances at the time of building the Roman roads. As to the roads built under Napoleon Bonaparte's regime, there are quite a number of them in Europe, they being the only good roads in their respective territories. It is a moral certainty that the French did not pay cash for the labor involved in the construction of Napoleonic roads; but Bonaparte seems to have carried out the antique principle of forcing the vanquished to his services.

Comparing the great ancient roads of Italy, France, Western Germany and Britain with the modern constructions, the thought forces itself upon us that works like the Pyramids or the Church of Notre Dame could not be paid for when they were built, nor could they be built to-day if payment should be required.

It seems that the construction of truly first-class roads cannot be enforced except during such cruel and tyrannic periods as those of Caesar and Napoleon. For public comfort is too nice a thing to be disturbed for the sake of public benefit, and discipline is next to impossible in any free State, the one exception in history being the case of the Roman republic. Whether the severe principles then in vogue paid for themselves is left to the student of history to decide.

# Patent Truths Concerning Varnishes

## Discussing the Phases of Automobile Finishing

*M. C. Hillick goes into the ramifications of varnishing work, discussing the merits of the methods in vogue and dwelling upon the shortcomings that are occasionally indulged in to the detriment of the results obtained. This article is intended to be helpful to the man who owns and operates a car, without in any way interfering with good workmanship as it obtains in plants of some distinction.*

WE borrow trouble, carry burdens, and wince under the yoke of many things connected with the wear and tear of the automobile, but not infrequently lose sight altogether of a main source of expense. At present there is a great gulf fixed between the automobile owner and the garage zouaves, and to cross from hither to yon, or vice versa, means an expense, figuring in the aggregate, which the man of moderate means is not daring enough to face. The item of large expense here referred to, and for which the garage employee, or the understrapper around the livery barn, or the man-of-all-work infesting the premises of the car owner, is largely responsible, is that of varnish abuse. As explained in a former article, varnish, and especially the finishing coat, is at once the most expensive and the most sensitive material that finds an outer point of vantage upon the surface of the car. At the same time, under fair treatment it is one of the most durable things which serve to protect and beautify the car.

It would almost seem, taking a broad view of the situation today, that a campaign of education is needed to insure for the varnish fabric upon the car a manner of treatment entirely free from abuse. Prejudice, deep rooted habits, generously mixed with ignorance concerning the vital essentials in the care-taking of varnish, are the traits of human nature entering into the practice to discourage which this article is written.

Varnish has very much of human nature in its composition and to go on eternally heaping upon it all the forms of abuse listed in the catalogue of cruelties is to invite a volume of expense at which even the millionaire has a right to balk.

To begin right with varnish after it has been flowed and fashioned upon the surface with the good practice of the brush artificer it should in no way be disturbed or exposed to service until it is dry and firm enough to take a generous water bath without bruising or clouding it.

And this water bath, let us understand at the outset, should not be forced through a high-pressure hose held at an angle to strike the surface with the force of a solar-plexus. Rather should it be a gentle flow of water distributed, if preferred, through the hose, and given a light pressure wash with a soft wool sponge. Let the water be clean and moderately cold, and after sponging the surface thoroughly dry it off down to a water mist with a soft, clean, wash leather which you buy of the jobber under the name of chamois skin, although it was more than likely cut from a Colorado sheep pelt.

All this suffices for a first washing, and this should be followed as often as the car goes out and accumulates a plaster of road dust or a smear of mud, either of which mediums is destructive to the varnish if allowed for any length of time to remain upon the surface. The ammonia with which roadway accumulations are saturated, working in connection with other alkalis, and deleterious substances contained in dust and mud, are highly injurious to varnish. Indeed, there is no other agency,

except hot water and fire, which will break down the brilliancy of varnish and permanently destroy its luster so quickly.

The need, therefore, of frequent water baths, applied in the manner described, is apparent. The abuse consists of first permitting these acid and actively destructive accumulations to dry and bake upon the surface or in washing them off with a powerful volume of water hurled at the surface at a high pressure. Abolish these two forms of abuse and you have cleared up two threatening and dangerous phases of the situation.

The next inexcusably bad practice consists in cleaning, or attempting to clean, the surface with waste or cloths saturated with various oils and smeary preparations, not a few of which are no more adapted for renovating or imparting life to the varnish than a skiff is suited to sail the high sea. All such mediums are too harsh and erosive in their effect upon the delicate field of varnish and they very soon nip off the sharp brilliancy which goes as a part of the well-finished surface.

Various emulsion cleaners have been, and are now being, recommended for the car surface to keep it bright and clean and to make the varnish wear longer. All such suggestions should be accepted by the motorist with several grains of allowance.

As to the merits of emulsion cleaners for the varnished surface upon the automobile, the question arises, What is the nature of an emulsion cleaner? Apparently some misunderstanding exists concerning this matter. An emulsion cleaner, under reasonable interpretation, carries ingredients consisting of water and alkalis, and, it may be, of acid. Moreover, it may also contain a percentage of oil. The oil is added in the case of some cleaners to neutralize the effect of the alkali, or the acid, or both. All such cleaners, however, are sooner or later—generally sooner—destructive to the varnish, and they should under no circumstances be used for automobile cleaning or renovating purposes. If you really wish to injure the surface to the extent that you would injure it with one of these innocent-looking emulsion cleaners, use common bar soap and water and save 90 per cent. of the cost of the emulsion cleaner.

If resort must be had to a cleaner other than water and possibly some light renovating body such as may be used upon pianos when the varnish has reached a certain stage of wear, employ a straight oil cleaner free from water, alkali or acid.

In any event, it is well to understand that a cleaner, be it oil cleaner or oil emulsion cleaner, or something masquerading under a more alluring title, should have nothing in its composition to blight or decompose the varnish. A straight, clean, soft-water bath applied to the car in the manner already directed is the very best treatment that can be given the varnish—as a matter of fact, it is the only treatment that should be permitted or tolerated—so long as the surface holds firm and intact and retains a fair degree of its original luster.

Reaching an advanced age the varnish may then, if so desired, be "flushed up" with some mild renovating medium containing a certain cleaning element in connection with a renovating and gloss-restoring ingredient.

Nevertheless, the sum of the whole matter is not to choke or throttle the varnish in the days of its youth by feeding it upon divers dopes of uncertain pedigree. Rather simply keep it clean by the application of water and common sense until the stage of decline sets in, whereupon either give it a fresh coat of varnish or apply frequently a renovating medium of established beneficial qualities.



# Practical Automobile Repairs

## Calibration of Parts Is Vital

*Time is fast drawing nigh when it will be possible for the amateur to repair his own car with moderate success, but it remains for the manufacturer to co-operate with the owner and deliver parts that will not require a greater deal of fitting. When parts wear it cannot be expected that a new part from the factory will just fall in and be a perfect fit. It is no use putting a square peg in a round hole.*

THE cry of standardization has been taken up wholeheartedly, and with the co-operation of manufacturers it will not be long before makers will have stocks of parts in different sections of the country, so that an owner of a car who finds himself in need of a new part to replace a broken or worn one will be able to obtain what he wants within twenty-four hours. It is still within the memory of many that one had to wait sometimes weeks for a spare part and in the case of some foreign cars the time bordered on the indefinite. This was an unfortunate state of affairs, but nevertheless it has been to America's advantage.

The manufacturer's responsibility does not end with simply supplying a new part speedily. It would be hard to find anything more exasperating than after waiting for several days, perhaps held up in some country town, to find that the part sent was not the one ordered, or that it was a case-hardened part several thousandths of an inch too large. Such examples have been by no means of uncommon occurrence in the past. A case in point was recently discovered in a race, where the clutch thrust raceway, which was made of three parts, had become overheated and seized, necessitating the replacement of a new part, which in the ordinary way could be performed in ten

minutes. The new raceway was offered up to the hole in which it had to fit and it was found that it was a matter of 0.0005 of an inch too large in diameter, and the unfortunate car was placed out of the race.

Jig work is fast becoming the usual method of manufacture in up-to-date shops, but a good deal depends upon the intelligence of the workmen in this rule-of-thumb method. One man is given a machine and a jig and he works from morning till night upon the same job, as, for example, drilling holes four at a time in a certain part. The drills must enter where the jig directs and the part must drop into the template or jig, but unless the locking of the jig is carefully executed the forethought of the designer will be nullified by an error that can only be found out in the running of the car.

Take, for example, the part shown at P in Fig. 3. This part connects the clutch to the transmission by means of an intermediary collar that fits over the squares of the part P and a corresponding part attached to the extension of the transmission shaft. The holes are drilled by two successive operations usually, or could all be drilled at the same time, for that matter. If the

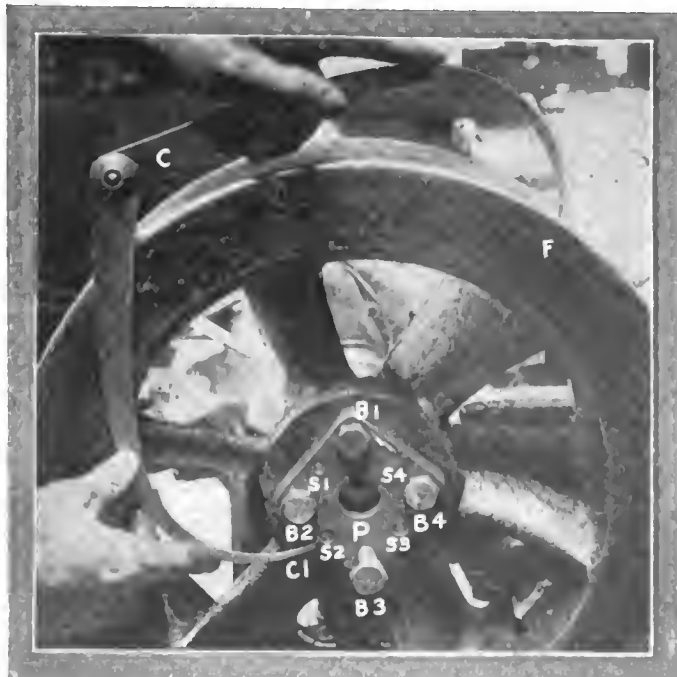

Fig. 1—Method of calibrating the part that has been attached by means of studs and bolts to the flywheel boss for concentricity



Fig. 2—Boss of the flywheel showing the studs that have been damaged through incompetent fitting

work is properly done, the fitter, when he comes to assemble the part to the flywheel F, will find that the holes S11, S22, S33, S44 correspond and register with the studs S1, S2, S3, S4, respectively. Then come the holding bolts that pass through the plate P through the holes H11, H22, H33, H44, and screw into H1, H2, H3, H4, respectively, and they may fit all right. The general appearance of the assembled parts is shown in Fig. 1. There still remains, however, the vital part of the work to be performed, and that is the outside calibration to correspond with the holes and studs and bolts. The alignment of the motor and transmission is dependent upon this, for unless the alignment is perfect

there will be undue wear on the universal joint and the dis-alignment may even cause a disagreeable knock at high speed. Incidentally, the part, although case-hardened, will wear and require replacement.

The case in point shows a Winton flywheel and the method employed in the shops and service departments of determining if the concentricity has been maintained in manufacture. Calipers are found useful in many ways on the car and in the garage of the private owner, as with this tool many small differences can be detected and wear located which otherwise could not be seen with the naked eye.

Shafts that are delivered by factories should have the centers left in them whenever possible, as it is difficult for the amateur

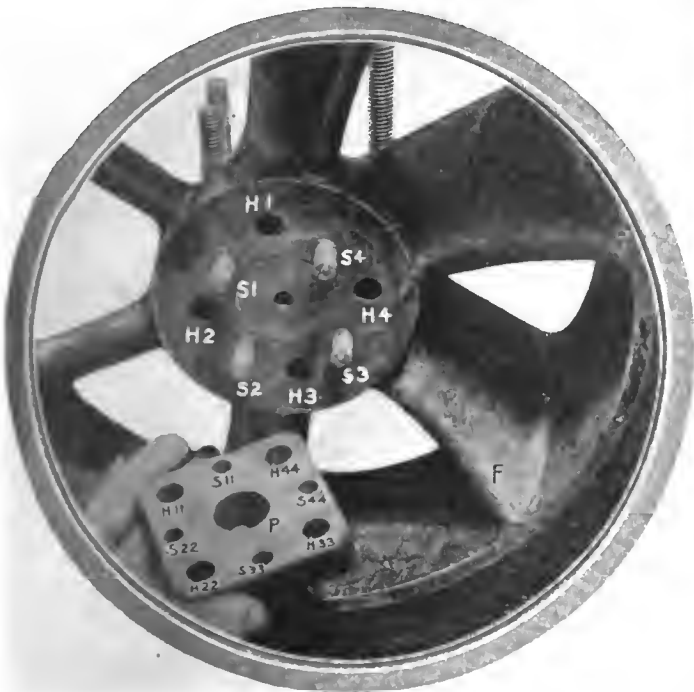

Fig. 3—Showing how the square block is attached to the flywheel and although it may fit on the studs properly, the outside squares may need dressing down

to recenter them. Fig. 2 is offered to show what might take place if the spare part were delivered with the holes badly drilled. If it were hammered on obliquely, as was the case in this particular instance, the studs will be burred, as may be seen at S4, and in a lesser degree at S3. Makers cannot be responsible for carelessness and want of experience on the part of operators of cars, and it is often better to let someone do the work properly in the first place rather than create work in undoing what has already been badly done.

### Inaccessibility of Fans

UNLESS the method of drawing the air through the radiator to cool it is carried out by means of veins in the flywheel, the usual method employed is to drive a fan placed in front of the motor by means of a leather or metal belt. The disadvantage of the metal belt is that it is apt to snap, whereas the leather belt, be it either of the twisted-hide or the flat variety, as here illustrated, will in time expand and require taking up. This is effected by various means, but when it is a question of removing the belt to take out a portion owing to the stretch that has taken place, this part of the work very often entails a good deal of trouble.

The best form of belt is one that has been sewn previous to being used on the car, and the method seen in the illustration of dismantling the fan and its attachments greatly facilitates matters. The spindle S passes through the slot of the bracket B, and the bush R, which has a hole drilled eccentrically to ac-

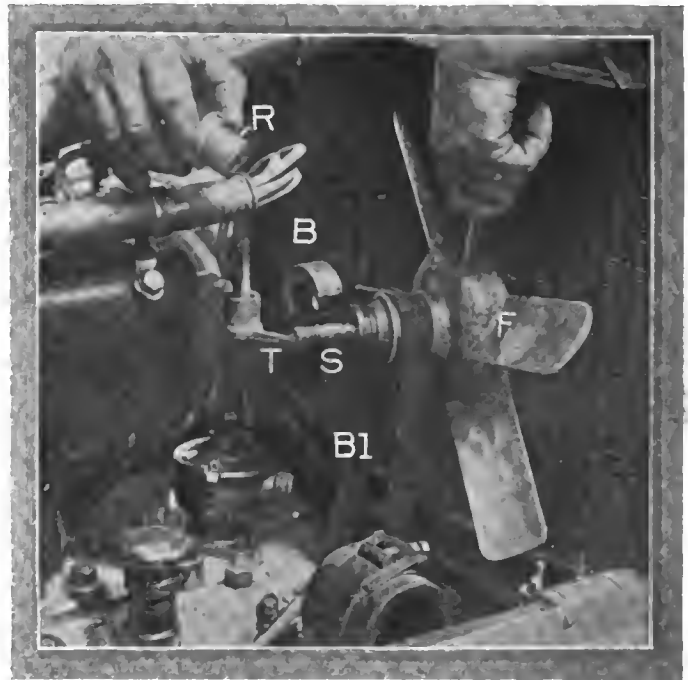

Method of attaching the fan to a bracket on the motor whereby ready dismantling is possible

commodate the spindle S, fits inside the bracket and is locked by a nut placed on the threaded end of the spindle. This operation, under the circumstances, should not take above a couple of minutes, and if the belt is not tightened after it has stretched the friction will wear the fabric quicker than if it was driving under tension.

### More Attention Should Be Paid to Details

NOW that the automobile is attaining a certain degree of definite form as regards the motor transmission and rear axle, not that there are not many ways in which these can be improved upon, it is the part of a wise engineer to look into detail matters appertaining to the car. Each point that is added is a talking one for the salesman and redounds to the benefit and comfort of the user. The matter of brake compensation has been tackled in many ways, but quite a lot of the fittings are heavy and unnecessarily clumsy. Quite apart from this side of the question there comes the matter of appearance, which must be pleasing to the eye as well as useful and practical. The time is not far distant when the public will demand to see the naked chassis without body embellishments and judge for themselves whether the lubrication is properly taken care of, if the brakes are so made that adjustments can be well and speedily carried out, and in general look for refinements that will make the car easier to take care of. The sides of a car are often marred by the side rods that are used to operate the rear wheel brakes, and these come outside the valances that are used between the chassis and the running boards to exclude mud and dirt. The method shown in the illustration obviates this, as the brackets that carry the arms are inside the frame, and consequently out of sight.

The bracket is similar to the type usually fitted outside the chassis frame but is less likely to be clogged up with mud. The cross-shaft is not shown in the illustration.

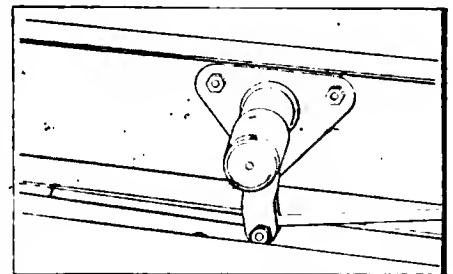

Method of carrying the bracket for the brake levers inside the chassis frame

## It Stands to Reason—

### (Applying Reasoning Power to Difficult Situations)

*In the face of a difficulty it may be the part of wisdom to resort to "presence of mind," or profit may come through the use of strategy—in either case the mind must be nimble, and to obtain this condition is a mere matter of practice.*

- THAT haste makes waste, excepting in the lubricating of an automobile, where no time is to be lost.
- THAT the constituency of a chauffeur is made up of the mechanisms under his charge, and if he wishes to retain the good opinion of his constituency he must diligently court that opinion.
- THAT the constituency of the owner of an automobile is made up of the car itself, the chauffeur, and the repair-man—it may be wisdom on the part of the owner to include his banker in the coterie.
- THAT the fragmentary information that the average salesman imparts gratuitously to a prospective is scarcely sufficient to clinch an argument to the satisfaction of a conservative person.
- THAT positive statements of alleged facts are the tools of those who are not on a speaking acquaintance with silent satisfaction.
- THAT a beguiling automobile may have so many "selling points" that they will become troublesome to the owner.
- THAT a shapely car when taken at its true estimate will have a certain harmony of relation of the mechanisms as well as appearance.
- THAT a villainous automobile will not begin to make a noise until the maker gets his check.
- THAT the man who can be lured by a decoy is pie in the hands of the glib-tongued agent who would foist a second-hand automobile in substitution of a new car.
- THAT nothing defeats success like too much earnestness of purpose on the part of the buyer of a car in contact with the fellow who desires to get rid of a second-hand automobile.
- THAT night time is the favorite for the delivery of a used automobile when it is being pawned off as a new car.
- THAT the purchaser of a car will be justified in withholding payment for the same until he can look it over in broad daylight.
- THAT the man who acts like a deity during the making of a sale has the devil for a wicked partner.
- THAT the most pleasing thing to a cultivated taste is an automobile that lives up to the promise of a salesman.
- THAT there is nothing to eclipse the reckless financiering of the man who uses tires that are too small for the car.
- THAT a motor, if it is maltreated, will have ample opportunity to get back at the bully who abuses its sensibilities.
- THAT the properly adorned body of an automobile is not necessarily red in color.
- THAT it is easy to convict a man of imprudence if he buys a large tonneau if his neighbor has a large family.
- THAT a man who has a liking for flattery may obtain the fullest measure by getting a car with more seats in it than he needs himself.
- THAT the demerit existing in an automobile comes to the surface after the salesman gets through exploiting the merit.
- THAT the fellow who toys with destiny to the extent of buying

two bad automobiles in succession might well take himself to a dark room and study the situation over.

- THAT the fellow who traded in one bad automobile for another, getting the latter from the same maker, displayed far too much confidence in humanity.
- THAT adroitness on the part of a salesman may uncover a pious desire to dispose of a second-hand automobile.
- THAT there are more mysteries in the world than those confined to chemistry, and a few of them are attached to the use of over-sized tires.
- THAT over-sized tires should be used on all the cars of a given model if they are employed on the demonstrating car of the same model.
- THAT a disinfectant will be scarcely sufficient to overcome the noise of an ill-contrived planetary gear.
- THAT magnificent poetry after it leaves the hands of the demonstrator frequently displays an abnormal lust for noise.
- THAT it would cost less money to overcome the troubles in a given model of a car than it does cost to keep these models sold.
- THAT the man who takes an automobile back to have it "half-soled" might well make a bargain with the repair-man and have the stipulation put down in black and white.

### Chains Require Attention

*Of all the parts which suffer from neglect through inattention, the chains on a chain-driven car are probably the chief sufferers. There is no doubt that if the method of procedure in cleaning and oiling a chain were known, the proper attention might be given in a great many cases.*

THE owner or driver of a chain-driven car should appreciate the fact that the chains need careful attention. While chains have been known to run an entire season without any care or additional lubrication, this practice is deprecated. To care for a chain properly, one should get into the habit of lubricating every so often and so time these intervals that they occur before the chain is in need of the oil. In addition to this regular lubrication, there should be some set time at the end of which the automobilist takes the chain off, cleans it thoroughly, and inspects it to detect faults.

A month is a good length of time for this, and an excellent way to proceed is to take the chain off and throw it into a pan of kerosene. In the morning, all of the dirt will have passed from the chain to the liquid and can be found in the bottom of the pan. Take the chain out and throw the liquid and dirt away. Then clean the pan and wash off all traces of the kerosene with gasoline. Having done this, hang the chain up to let the gasoline evaporate.

The chain then will be both clean and dry. Now inspect all rollers, links, rivets and bushings, taking note of any unusual wear as indicated by looseness or play. If defects are found, they should be remedied. Then, having the chain clean, dry, inspected and passed upon as O. K., an excellent method is to soak it, or, better, boil it in a heavy melted lubricant. The best quality of beef tallow mixed with a little graphite is good. Many do not like the latter, in which case a high-grade oil may be substituted for the purpose.

# As to the Merits of Vanadium

## Lake and Norris Vigorously Lock Horns

*E. F. Lake discoursed under the caption "Alloy Steel for Automobiles" in THE AUTOMOBILE of June 29, and George L. Norris expresses his disapproval of some of the doctrines indulged in by Lake in the article referred to, and the communication here presented gives Mr. Norris' version of the vanadium situation with which Mr. Lake generously disagrees.*

### How Vanadium Looks Through the Eyes of George L. Norris

WE wish to take exception to some of the statements made in an article entitled "Alloy Steel for Automobiles," and published in your issue of June 29. From the introduction of this article we judged that it was intended to be an authoritative source of information for the automobile manufacturer and engineer.

The subject of the paper, "Alloy Steel," seems to have been carefully chosen, as the author eliminates from consideration practically all alloy steels excepting chrome-nickel. In the third paragraph of the article this statement appears: "The much-advertised vanadium steels have shown some good properties, but when submitted to various kinds of tests they have not taken the place of chrome-nickel steels." We expected to find in the later paragraphs some description of the qualities of vanadium steels, but were surprised to find the following: "Of the vanadium steels very little, if any, vanadium is present in the finished product and hence vanadium steel is a misnomer. Vanadium has great affinity for oxygen and also for nitrogen and if added to the bath just before teeming into the ladle it will seize these and carry them off into the slag. By thus scavenging out the oxides and occluded gases it retards the formation of blow-holes and the segregation of the carbides and makes the metal more homogeneous and also more easily machined. Aluminum performs a very similar mission, but yet we do not speak of aluminum steels."

While vanadium possesses a certain peculiar efficiency over silicon, aluminum and titanium as a scavenger it is not primarily used for this purpose, and the object of the steel maker is to alloy with the steel the highest possible percentage of the vanadium which he adds. The beneficial effects of percentages of vanadium varying from 1-10 of 1 per cent. up to 1 per cent. and even more have been definitely determined. Mr. Lake then continues: "Vanadium of itself adds no virtues to steel. When it has cleansed the steel of impurities it has performed its mission; thus it is as well to allow it to go off into the slag as to try to keep any in the steel, unless the steel maker wants to prove to the chemist that it is vanadium steel. That slags can be used in an electric furnace to perform the same mission of purifying the steel has been thoroughly demonstrated and this may overcome the necessity of using as expensive an alloying material as vanadium."

The experience of a large number of steel manufacturers who are producing vanadium steels regularly and the experience of the people who are using vanadium steels in automobile construction and a variety of other uses is overwhelmingly opposed to this statement and it should not have been at all difficult for Mr. Lake to have made himself familiar with the true ideas.

The steel maker before he makes a heat of vanadium steel has a fixed idea as to the percentage of vanadium he must obtain

in the steel to produce certain results in the finished article. The steel that does not contain vanadium as shown by analysis is not a vanadium steel and will not exhibit the qualities, both static and dynamic, of vanadium steel. It is not a question of proving to the chemist that vanadium has been added; it is a question of having vanadium in the steel because by countless tests it has been proved that vanadium produces definite beneficial results.

The statement is made that vanadium steels have shown some good properties, but that when submitted to various kinds of tests they have not taken the place of chrome-nickel steel. Mr. Lake then proceeds to describe a chrome-nickel steel which he considers one of the best, but which is actually being looked upon with disfavor by many of the best automobile engineers and metallurgists because it is an unsafe steel. The legitimate field of Mr. Lake's chrome-nickel steel is for the manufacture of gears, and even in this field its supremacy has declined in favor of chrome vanadium steels. As for using this steel for front axles and steering knuckles we believe Mr. Lake's advice on this point is very unsound. It is true that vanadium steels, by which we mean various alloy steels containing vanadium as a component part, have replaced chrome-nickel and nickel steels to a very large extent in automobile parts. A great number of cars, including not only the low-priced machines but some of the highest-priced types, are made from steels containing vanadium. Against the opinion of Mr. Lake we quote from so well-known and universally recognized an authority as Prof. J. O. Arnold, of Sheffield, England: "Vanadium is undoubtedly the element which together with carbon acts with the greatest intensity in the way of improving alloys of iron, that is to say, in very small percentages." Professor Arnold is of the opinion that vanadium combines to form a double carbide of iron and vanadium, that it seems to have not only a chemical but a physical influence in promoting the even distribution of the carbon, and retarding constitutional segregation. He infers from this and other experimental evidence that there is strong reason to believe that very small percentages of vanadium will largely enable steel to resist the deterioration which under constant vibration leads to brittleness. This opinion of Professor Arnold's has been completely confirmed by the record of vanadium steels during the years that have lapsed since his statement, and they have well earned the name of "anti-fatigue steels." Mr. Lake's statement that slags can be used in the electric furnace to perform the same mission of purifying the steel as vanadium, and that this may overcome the necessity of using as expensive an alloying material as vanadium, can be answered most conclusively by the fact that manufacturers of electric furnace steel are to-day producing vanadium steels and making no pretense that they are able to produce steels of the same qualities without vanadium—the composition being otherwise the same. Vanadium so profoundly affects the physical qualities of the steels to which it is added, through its intensifying effect upon the other elements in the steel, carbon, chromium, nickel, silicon, etc., that these steels can properly be termed vanadium steels without misnomer.

To quote from Dr. John A. Mathews: "From a wide experience with all types of alloys, it is my opinion that where a better material than the best nickel steel is needed, and especially when dynamic excellence is sought, the appropriate types of vanadium-chrome steels may be unreservedly commended. They forge well and machine more readily than chrome-nickels of corresponding carbon percentages."

While nickel-chrome and nickel steels will undoubtedly always

continue to be made, they are being replaced by chrome-vanadium and chrome-nickel-vanadium steels on account of the superior static and dynamic qualities possessed by the vanadium steels.

The widespread use of vanadium steels in automobile construction for gears, rear axles, shafts, steering knuckles and levers, crankshafts, propeller shafts, valves, piston rods, springs, etc., is incontrovertible evidence that vanadium does add to the virtues of steel, for it is inconceivable that the manufacturers of automobiles would adopt vanadium steel to the great extent they have without familiarizing themselves with its qualities.

As a matter of curiosity I would like to have Mr. Lake explain how by the crucible steel process it is possible to reduce the sulphur and phosphorus to a greater extent than by the open-hearth process.

#### What E. F. Lake Thinks of the Norris Type of Criticism

**I**N an effort to criticise my article Mr. George L. Norris starts off by saying it is worthless, without offering any kind of evidence, submitting a few facts, or giving data to prove his assertions, or show that misstatements have been made. Words have been multiplied, but in his whole criticism it is difficult to get hold of any facts or real data on which to base an argument. For instance, he takes exception to my statement that "Vanadium of itself adds no virtues to steel. When it has cleansed the steel it has performed its mission, etc." In trying to refute this statement he says, "The experience of a large number of steel manufacturers is overwhelmingly opposed to this statement—it is a question of having vanadium in the steel because by countless tests it has been proved that vanadium produces definite beneficial results." Absolutely no facts or data have been presented in confirmation or proof of this statement of his and yet he says there are countless tests. Why has he not submitted one of these?

A great deal of experimenting and testing has been carried on with vanadium-treated steels and practically all of these have shown that titanium has a great affinity for oxygen and to a considerably lesser degree for nitrogen. In the manufacture of high-grade steels, carbon, manganese and silicon are made to deoxidize the bath as much as is commercially practical. After this has been done the remaining oxygen and nitrogen can be further reduced if ferro-vanadium is properly added. In doing this most of the vanadium used goes off into the slag with these gases. Enough should be used, however, so as to leave about one-tenth of 1 per cent. of vanadium in the steel. The steel-maker will then be assured that it has thoroughly permeated the bath and seized all of the oxygen and nitrogen it is possible to bring it in contact with.

In this work it has performed a useful mission and nearly all the metallurgists who have investigated it have shown that its main mission is that of a scavenger. The literature of the American Vanadium Company has said this many times. While Mr. Norris has made statements, none of the investigators have submitted proofs that vanadium of itself adds any beneficial properties to steel. Professor J. O. Arnold, who is quoted by Mr. Norris, has not made any definite and positive statement to that effect. All of his statements are qualified with a word of doubt and thus show that until more complete data has been submitted he is not willing to make any positive statements. When Mr. Norris says, "It seems to have not only a chemical but a physical influence in promoting the even distribution of the carbon and retarding constitutional segregation," it does not necessarily mean what Mr. Norris wants it to mean.

By acting as a scavenger to remove the oxygen and nitrogen and thus prevent the formation of oxides and nitrides it would retard the segregation of the other elements in steel and cause a more even distribution of the carbon. It would also prevent the occlusion of gases to a large extent as well as the formation of phosphides and sulphides. In removing the above two gases it prevents other elements from forming combinations that are harmful to steel. It thus overcomes brittleness, refines the grain

and makes the metal more homogeneous. This would cause it to have a greater resistance to rotary or vibrational strains, impact blows, or torsion as well as have higher static strengths.

The mere statement that a large number of steel manufacturers are producing vanadium steels regularly proves nothing except that they are supplying a demand.

Mr. Norris attempts an argument against my statement that various tests have shown that vanadium-treated steels cannot take the place of chrome-nickel steel. Again, however, absolutely no evidence, facts or data have been submitted. Countless tests have been made with vanadium-treated steels in comparison with other steels, but not one of these tests has shown us that vanadium treated steels equal either the static or dynamic properties of chrome-nickel steel; in most cases they could not nearly approach it.

The electric furnace for manufacturing steel is yet being experimented with in all kinds of ways. They are also producing all kinds of steel with them. Because some of these are vanadium-treated steels does not necessarily mean that the impurities removed by vanadium cannot be removed by using correct methods and slags in the electric furnace. If Mr. Norris had submitted any data to prove that vanadium-treated electric furnace steel is any better than electric furnace steels made without vanadium we might be inclined to listen and look for further data along this line.

As this argument is on vanadium, I will only say of the nickel-chrome steel that I called one of the best grades that it has been used by two engineers that I know of for the most vital parts of the automobile and gave better results than they obtained from other steel.

The widespread use of vanadium steels for numerous parts mentioned by Mr. Norris in his next to the last paragraph absolutely does not prove that "vanadium of itself adds any virtues to steel." It could just as readily prove that vanadium has fulfilled its mission when it has removed impurities and gone off into the slag, and thus strengthened and improved other properties of steel. Titanium, which in the ferro form is about one-twentieth of the cost of vanadium, has as great an affinity for oxygen and a greater affinity for nitrogen, it being the only undisputed example of the combustion of an element in nitrogen. This element will therefore give us practically the same results that are obtained with vanadium, and its growing competition may be the cause for the claims that vanadium of itself, in the proper percentages, adds to the static and dynamic properties of steels.

Neither in my original article nor in this answer to Mr. Norris have I said that vanadium did not produce beneficial results in iron or steel when properly alloyed and used in the correct percentages. The injurious effects of oxygen and nitrogen have been much more clearly brought to our attention since the advent of vanadium and much valuable data is thus at hand. That titanium or other elements still in the experimental stage or even the electric furnace will give us just as good results by removing the impurities is fast being demonstrated. As these are cheaper than vanadium they may take its place in steel making and leave to vanadium the medicinal mission claimed for it.

To satisfy Mr. Norris's curiosity, I will say that I do not think it possible to reduce sulphur and phosphorus by the crucible process to lower percentages than can be done in an open-hearth furnace. The possibilities of the open-hearth furnace are very great. By using the proper methods or slags it is possible to reduce sulphur and phosphorus to mere traces in an open-hearth furnace. This, however, costs money and makes the steel expensive. It is not possible to reduce these elements in the crucible, but the materials charged into the crucible must be such as will make their percentages low when the steel is poured into ingots. Ignoring possibilities, therefore, the probabilities are that when we buy commercial steels the crucible product will be lower in phosphorus and sulphur than the open-hearth product, as by charging the proper materials the phosphorus and sulphur are reduced to lower percentages in the crucible than in the open-hearth process.



# Energy Diagrams and Efficiency

## Showing How Available Energy Is Dissipated

*Gasoline as it is poured into the tank of an automobile inherently contains a certain amount of energy and it is proposed in this article, that originally appeared in La Vie Automobile, to show how energy is lost through different channels before it arrives at the road wheels. It is suggested that makers should state the power of the motor as one unit and the power available at the road wheels as the other, thereby informing buyers as to what they are purchasing.*

**T**HE title of this article may appear complex to some, but in reality it is a simple question and, besides, is one that should interest the majority of car owners.

Every one knows what is meant by efficiency of a car; but as the word "efficiency" may have been used in other connections it is as well to be specific. If one were to put 10 liters (17.598 pints) of gasoline into the tank (weighing 0.7 kilogrammes to the liter) and possessing 10,000 calories (mean value), one would have for nourishment of the motor  $10 \times 0.7 \times 10,000$  calories.\*

It is possible to transform these calories into work in the form of kilogrammeters. (There are 7,233 foot-pounds in one kilogrammeter, one calorie equals 425 kilogrammeters, or 3,968 British thermal units, and one British thermal unit is equivalent to 778 foot-pounds.)

If the motor produces 75 kilogrammeters in one second it is said to have a power equivalent to one cheval-vapeur (which is equivalent to .9863 horsepower). To be exact, one horsepower is equivalent to 75.9 kilogrammeters per second.

With the 77,000 calories thus furnished to the motor we would be able to obtain, if the transformation was integral without loss,  $77,000 \times 425$  kilogrammeters 32,725,000 kilogrammeters.

The ten liters of gasoline consumed in one hour would therefore give

$$\frac{32,725,000}{3,600 \times 75} = \text{cheval-vapeur.}$$

This is far from being correct because a 12-horsepower motor running at maximum power would not consume

\*Calories—Any of several heat units. The amount of heat required to raise the temperature of one gram of water one degree centigrade; called specifically small calorie. Since the specific heat of water varies slightly with the temperature, the rise of one degree is sometimes specified to be from 0 degree to 1 degree, or at or near 4 degrees (the temperature of the greatest density) or from 15 degrees to 16 degrees. In this last case the value of the unit is almost exactly that of the mean calorie. The amount of heat required to raise one kilogram of water one degree centigrade. 1000 small calories, called specifically large or great calories. 1 calorie = 3,968 British thermal units. The amount of heat required to raise one gram of water from 0 degree to 100 degrees centigrade is known as centuple or rational calorie. One-hundredth of the centuple calorie is called mean calorie.

more than 10 liters per hour and (because it would be able to do at least 150 per hour) 6.6 per hundred kilometers. It is necessary to multiply by about 10 to approximate the actual consumption of such a car, as, for example, 66 liters. This consumption of 10 liters per hour and at full power corresponds rather to 12 horsepower than to 120 horsepower.

Therefore, instead of obtaining 121 horsepower at the road wheels at the point of contact with the road surface, this amount is nearer to 12 horsepower, i.e., 10 per cent. That is to say, that a car that only gives 10 per cent. of the amount furnished is said to have a 10 per cent. efficiency. It is quite small, but, as is found out in practice, this is about the average. Certain cars could go as high as 15 per cent. (in which case they would have to furnish 18 horsepower), but this is a point rarely attained.

### Where Does this Wasted Energy Go?

The motor for a start wastes a considerable amount. It only furnishes one-third of what one would be able to obtain on the crankshaft, as, for example, in the case of a dynamo. But in the transformation of energy from the clutch to the rims of the rear wheels there is a large proportion lost in transit. It is possible to measure these losses on the test bench by certain convenient apparatus. One can determine to which part to attribute the waste of energy—a liquidation so to speak—be it the motor, transmission, wheels or tires, and so on.

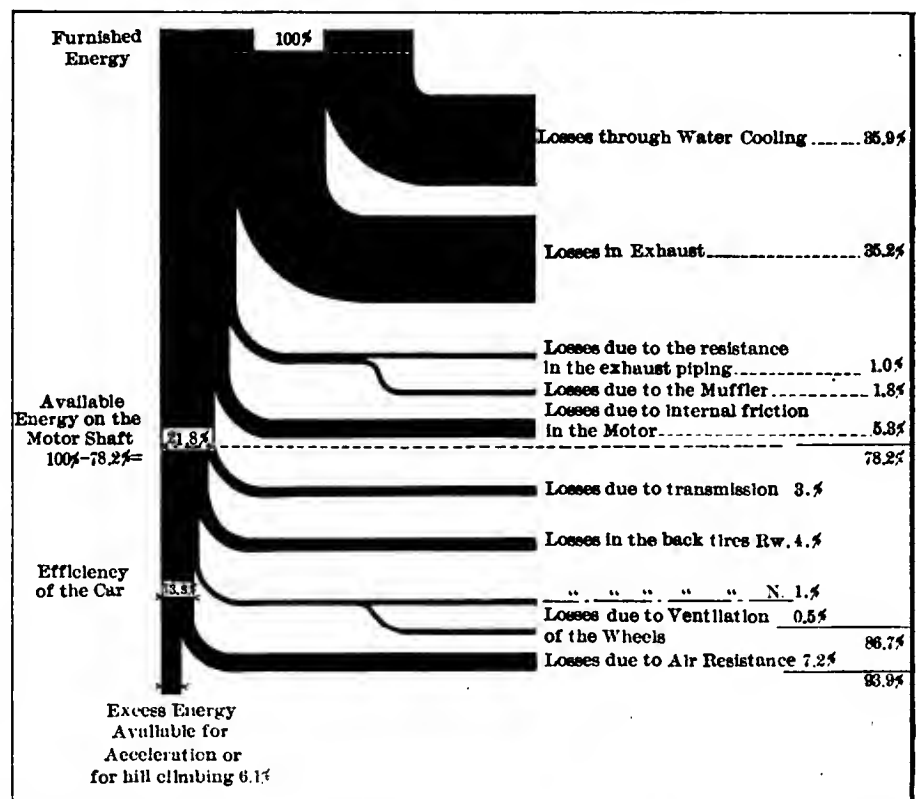

Fig. 1—Energy diagram of a 30-horsepower car running at 37 miles an hour (60 kilometers) on a level road, and the way the energy delivered by the gasoline is dissipated. The available energy at the crankshaft is only 21.8 per cent. of the total energy furnished. The motor and transmission comprising 86.7 per cent. of the total energy, leaving 13.3 per cent. to combat the air resistance, grades and acceleration efforts; at 37 miles per hour 7.2 per cent. is absorbed in air resistance, leaving 6.1 per cent. for grade resistance. This surplus is totally absorbed on a grade of 6 per cent.

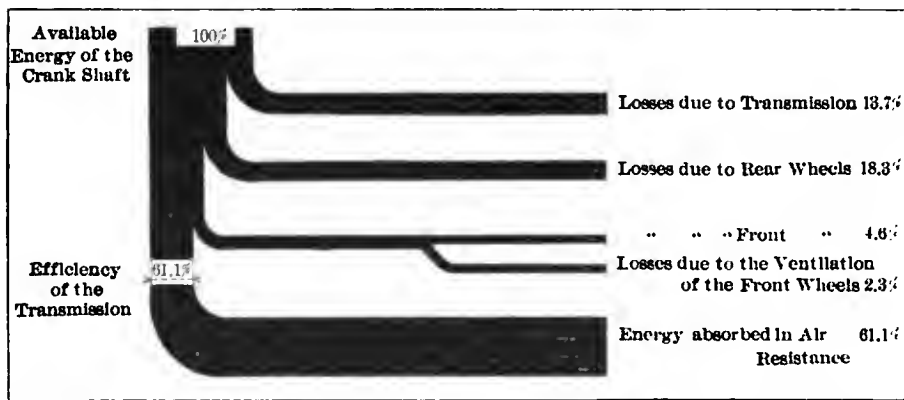

Fig. 2—Energy diagram of a car taking into consideration the amount of energy available at the crankshaft. The motor is driving the car at 69 kilometers (43 miles) per hour. All surplus power is absorbed by wind resistance

These partial results can be calculated and expressed in energy diagrams. An energy diagram is one that appeals to the senses; they can be constructed in various methods. In Fig. 1 is shown a simple one.

As the term liquidation has been used above it will be as well to continue the simile, which is a convenient one, and let it represent the energy in a liquid form that would flow from the motor to the rear wheels. En route there are tributaries by which some part escapes.

Fig. 1 represents the diagram of energy of a car traveling at 60 kilometers per hour with the motor working at full power. Of the 100 per cent. of energy furnished 78.2 per cent. is lost in the water cooling, through the exhaust manifold and on account of the frictional losses in the motor.

All that is left of the total energy that will be available at the crankshaft will be 21.8 per cent. If one were able to utilize the available energy at this point the conditions would be ideal, but this energy must be transmitted to the driving wheels, and in this undertaking some more is lost, for example, 3 per cent. in the transmission proper (there are numerous channels through which it can flow, such as gearing, frictional losses, etc.). On arriving at the wheels 0.5 per cent. is taken off in the ventilation of the wheel; that is to say, 0.5 per cent. of the primary energy furnished is utilized in overcoming the work of the ventilation of the spokes of the wheels.

Lastly the tires absorb a goodly proportion of what is left, the rear wheel tires pre-empting 4 per cent. and the front tires 1 per cent. Finally there is left at the point of contact of the wheels and the road surface 13.3 per cent. of the primitive energy, of which a little more than half, 7.2 per cent., is absorbed by the resistance of the air—that is to say, the work of penetration of the car through the air—and there remains 6.1 per cent., which it is not proposed to use at the present moment, but which will permit us to slightly increase the speed (in this

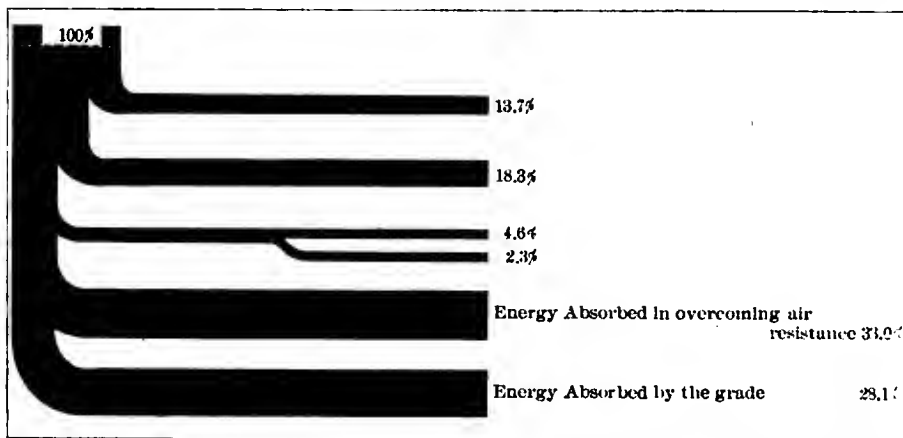

Fig. 3—Energy diagram of a 30-horsepower car running at 60 kilometers (37 miles) per hour, on a grade of 6 per cent. (relating to the energy available at the crankshaft); 33 per cent. of this energy is absorbed in wind resistance and 28 per cent. by the resistance of the grade

example to bring it up to 69 kilometers per hour) or to overcome the resistance of a slight gradient.

Division of Power

Taking up the example of the car consuming 10 liters of gasoline per hour, we have seen that if the 100 per cent. of energy thus furnished were delivered in the form of work we would be able to make use of fully 121 horsepower.

If the diagram of energy shown in Fig. 1 were applied to this motor the 121 horsepower would be split up in the following manner showing how the available power is absorbed at the various points.

Available power on the crankshaft.....	26,378	horsepower
Available power at the rims.....	15,093	"
Absorbed by air resistance.....	8,712	"
Available for acceleration and gradients....	7,381	"
The wheels and tires alone absorb.....rear	4.84	"
front	1.815	"

From this tabulation an idea of the efficiency of a car can be obtained. It is these two characteristics, viz., power available at the crankshaft and power available at the rear wheels that first started the use of appellations of car such as 10-14, 20-24, 15-20, 30-40 horsepower, etc. In the following example we will call this car a 15-25 horsepower, and this designation will be quite rational. The buyer who purchases a 15-25 horsepower car will know just what he is buying. But numerous abuses have robbed this designation of all value. One usually understands what is meant when a firm calls their car a 14-20 or a 30-40, but it is possible that some would not understand what was meant by 8-80 horsepower.

It would be very simple to approximately gauge the available power at the rim, which can be measured on a testing apparatus such as that used at the Automobile Club. As cars are for the most part constructed in series it would be sufficient if the maker were to submit one model of the series for a test which would neither be very costly or long and in this manner one of the vexatious questions would be settled.

The diagram has been plotted to show the commercial or normal speed of the car and not the maximum speed. This commercial speed is the one in which the efficiency of the car is found at its best. If the diagram had been plotted for the maximum speed we would have one similar to that shown in Fig. 2, in which the starting of 100 per cent. has been chosen as the available energy at the crankshaft and not furnished energy. Fig. 3 represents a diagram of a car climbing a grade at 60 kilometers per hour. The resistance of the air and the resistance due to the grade absorb practically all the energy available at the rim.

These diagrams are interesting because they permit one to compare the different degrees of absorption and the quality of different cars. The point that is of interest to the purchaser and the maker alike is the amount of energy available at the rims of the wheels. When this characteristic is known it will be an easy matter to work out the ratio of gearing that would offer the best results. It is easy, as a matter of fact, to roughly approximate the energy that is absorbed by the air resistance at different speeds of running when the windage area is known. With these data to work upon one would know how much reserve power there is

available for accelerations of the car and grades on the different speeds.

If one wants a car that will climb hills easily even when heavily loaded, and without changing speed, a sufficient amount of reserve power must always be available. The more the reserve power one has the more pleasant it will be to drive the car, the quicker will be the starting qualities and the easier it will climb small hills.

On the contrary, if the excess power is small the driver will be forced to continually play with his levers and pedals. In the example chosen the car has a windage area of 2 square meters (21 square feet). If it were stripped for racing and the resistance were reduced to 1 square meter (10.764 square feet) the excess power would be much greater at 60 kilometers (37 miles) per hour—viz., 9.7 per cent. instead of 6.1 per cent, and with the same weight, 1,800 kilogrammes, the car would be able to climb a much stiffer hill.

## How Steering Gears are Assembled and "Run In"

THE steering of some cars is particularly soft and easy of operation, which is due to proper balance and a good fit of all the parts, whereas the driving of another car, instead of being a pleasure, becomes a feat of muscular endurance. No doubt in time some of the stiffness will wear off, but high spots should be carefully removed before the car is handed over to the purchaser. The following method is the one employed in the Packard factory:

The throttle operating parts which are on the steering post are first assembled as a separate unit—the rod that goes inside the post, with the sleeve, collar and rocker arm at the lower end and the worm, throttle nut, lever, etc., at the upper end.

The steering worm and its shaft (which are one piece) are case-hardened and ground, then brazed into the post, and the bearing surfaces again ground. This and the steering wheel are the only composite parts that reach the assembling room out of the 184 different pieces that enter into the post construction.

A temporary steering wheel W is attached for "working in" the post, so that the permanent wheel may not be marred or soiled. The post is covered with a leather gaiter G for protection.

When the assembly is complete it is bolted to a solid rigging B on the floor, and first tested for any "play." Play cannot always be detected by manipulating the wheel with the socket in a vise. If play is detected, the post goes back to the bench and is readjusted.

With the post again bolted to the floor rigging, the sector lever A is attached by the steering connecting rod R to a hydraulic apparatus which imposes the same strains or conditions that are met with in road service with the car loaded. The expert takes it in hand, and by manipulating the different valves V in the test machine he gets the effect of driving over bumps and "thank-you-ma'ams" in a road, straight ahead and around the curves.

The steering-gear valve is operated by the backward and forward motion of the water pump and as the connecting rod R is attached by a ball socket to the piston rod, which latter is guided in the bearings B and B<sub>2</sub>, the steering is allowed to run itself in and thereby take off any high spots.

## Center-Studded Detachable Non-Skid Treads

SUPPLEMENTAL treads on tires are now widely used, and there is more than one point to be said in favor of them; among others, that these treads offer the possibility of using a non-skid tread when it is deemed advisable to do so and which tread may be removed whenever the driver wishes. The protection afforded to the tire by the use of a well-fitting cover

is a fact not to be decried, and it is generally in the small details that the various makes of detachable treads differ. In the selection of such treads, buyers lay most stress upon the possibility of quick adjustment and of maintaining tightness against the face of the outer tire shoe, which are indeed matters of con-

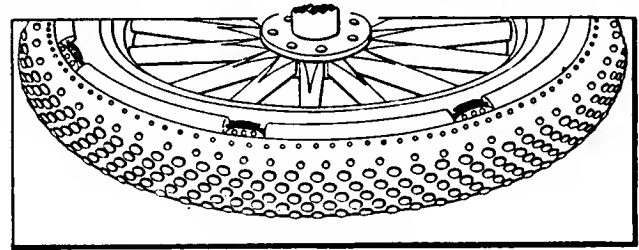

Illustrating the center-studded Woodworth tread

siderable importance, especially the latter one; since the shoe will necessarily heat up if the outer tread slips on it, in which case the tire will suffer more than if it were running on the road itself.

As an example of a non-skid detachable tread the Woodworth is shown in the illustration, it being the product of the Leather Tire Goods Company, of Niagara Falls, N. Y., and it will be well to call attention to the fact that the steel non-skid studs are only in the center portion of the tread, this being the part where it comes in contact with the road and which has to stand the continued working strain. The studs, as may be seen from the wax engraving, are set in several parallel rows, thus insuring prompt anti-skid action.

The illustration also shows the manner of fastening the tread to the tire. On both edges of the tread rings are provided which are composed of coil springs, of which there are six or eight. They are connected up by hooks and links in the manner seen in the cut, and a special tool is delivered to the buyer of every set, which permits of connecting up two springs by a single motion. This arrangement warrants tightness of the tread against the tire, and easy and rapid adjustment and detachment of the tread.

The center-studded tread has been designed with a special view to city work in which good roads only have to be encountered, generally speaking, in which cases, therefore, the protection of the central portions of the tire will fill all requirements. Owing to its character, the tread protects the tire against blowouts and punctures and, except when the car runs at very high speeds, the center-studded tread will be found very efficacious. In fact, if it is made to serve under the conditions it is intended for, it will be just as good as a full-studded tire, with the obvious advantages of less weight and price owing to its method of manufacture.

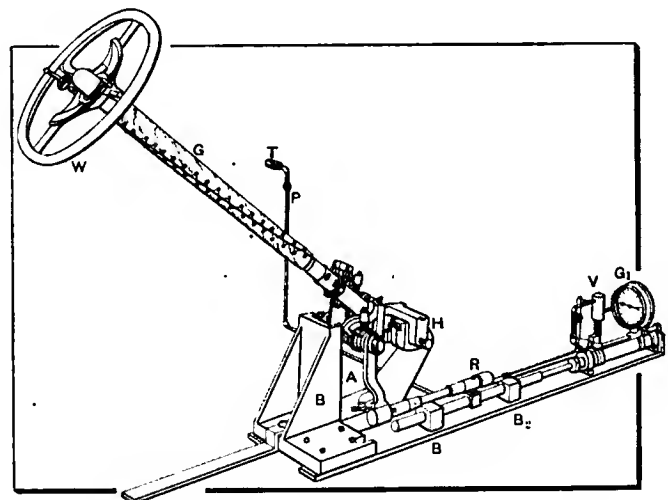

Showing the operation of running Packard steering gear

Wants Information About Strange Motor

Editor THE AUTOMOBILE:

[2,754]—The other day I was examining a motor which seemed to be of the two-cylinder type with the cylinders cast en bloc. I was under the impression that it was an extraordinarily large diametered motor and on inquiring found that it was a four-cylinder motor with the cylinders alongside of each other. Will you kindly show me by means of a diagram how these cylinders are placed? CHAS. STEVENS.

Davenport, Iowa.

The motor described by you is shown in section in Fig. 1. Referring to the cut, it is seen that the cylinders are inclined to form a V-shape with each pair of connecting rods working on the same crank. There are three flywheels within the motor which are connected to the cranks and crankshaft in the manner shown in the longitudinal section through the motor.

Desires to Paint His Own Automobile

Editor THE AUTOMOBILE:

[2,755]—I have a 1906 Model, 5-passenger touring car, with a white body. I wish to paint it black myself, with the running parts and wheels straw. Please give me directions or refer me to some firm who will furnish materials and directions. SUBSCRIBER.

Midnight, Miss.

If the surface of the car body is in good condition, that is, free from checks and fissures, it should be thoroughly sandpapered, after cleaning off all oil and grease spots, with No. 1 sandpaper, and coated solidly with a coat of ivory black, japan ground, and thinned to a brushing consistency with six parts turpentine and one of raw linseed oil. Let this coat dry overnight and then rub the surface down

lightly with fine curled hair, which may be obtained from any local upholsterer or carriage trimmer. Then dust off and apply a second coat of ivory black thinned in eight parts of turpentine and one part of raw linseed oil. For applying this thin color use for a touring car surface a 2 1-2-inch camel's hair double thick brush. Put this second coat of color on, say in the morning, and during the afternoon apply a coat of black varnish color. This varnish color may be shop-mixed by first thinning with turpentine and then adding sufficient elastic rubbing varnish to produce a sharp luster. The proportions should be 1-4 pound of color to 2 1-2 pounds of varnish. Preferably, however, this varnish color may be bought in the form of black rubbing varnish direct from the manufacturer. Apply the varnish color with a half-elastic bristle brush, flat width 2 1-2 inches. Let this coat stand two days, whereupon rub lightly with a piece of

The Editor invites owners and drivers of automobiles who are subscribers to THE AUTOMOBILE to communicate their automobile troubles, stating them briefly, on one side of the paper only, giving as clear a diagnosis as possible in each case, and a sketch, even though it may be rough, for the purpose of aiding the Editor to understand the nature of the difficulty. Each letter will be answered in these columns in the order of its receipt. The name and address of the subscriber must be given, as evidence of good faith.

advised, wash up and finish with a high-grade finishing varnish. For a cheaper job omit one coat of the rubbing varnish and for a quicker schedule, use quick-drying rubbing varnish.

If the body surface is checked and fissured to a considerable extent sandpaper the surface after cleaning up, and apply a coat of lead-colored pigment darkened to a slate color and made of oil, ground white keg lead and lampblack, and containing enough oil after thinning with turpentine to bind the coat securely to the white foundation. Putty all defects in this surface very carefully, and proceed with the color coats as already detailed.

For the chassis or running parts, if the surface is in good condition the straw color may be applied directly upon the white, which color, by the way, makes an ideal background for straw. The straw color may be procured of any first class color grinder or it may be mixed in the shop of 5 parts of arctic or flake white, 2 parts lemon yellow and a drop or two of English vermilion. Use the japan ground yellow and white in making the straw color, and thin out with turpentine and raw linseed oil in the proportions advised for the color coats on the body. Apply two coats of the flat yellow on the chassis and then one coat of yellow varnish color, rub lightly on this coat with water and pulverized pumice stone, stripe in single, double or three lines as preferred, apply a coat of quick or medium-drying rubbing varnish and in due time rub down as before and finish with a good grade of chassis varnish. For a cheaper job omit the rubbing coat of varnish.

To Prevent Tire Pinching

Editor THE AUTOMOBILE:

[2,756]—Having recently purchased a car and seeing that you are kind enough to give advice to beginners through the correspondence columns of your paper, I take the liberty of asking you to help me. I have mastered the mechanical parts of the car fairly well, but the tires cause me great anxiety. I do not drive fast, which I understand is the greatest source of tire

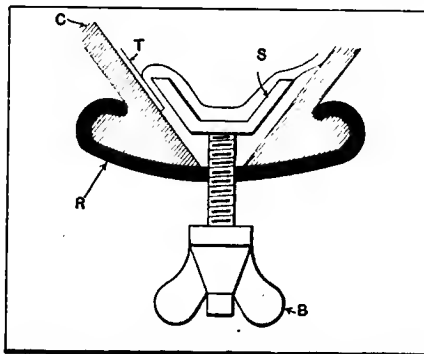

Fig. 2—Showing how tube is pinched by security bolt not brought properly into position. B, bolt; C, casing; T, tube; R, rim; S, security bolt

broadcloth dipped in water and pulverized pumice stone. Wash and clean the surface thoroughly and apply a coat of elastic rubbing varnish, to which should be added a teaspoonful of ivory black to each pint of varnish.

This black counteracts the discoloring properties of the varnish. Permit this coat to stand 4 or 5 days, the longer the better, then with a perforated piece of 1-2-inch felt dipped in water and then in the pulverized pumice stone rub the surface very thoroughly and uniformly, wash up and apply the necessary lines of striping. When these are dry, apply a coat of the clear elastic rubbing varnish, and after another four days rub with water and pumice stone, as above

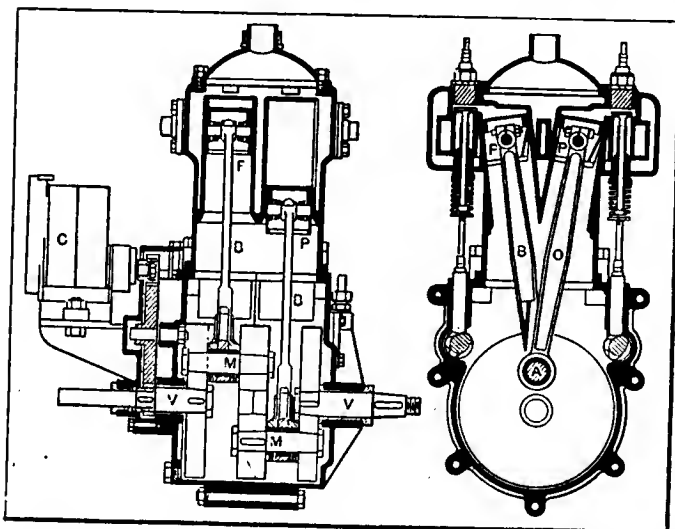
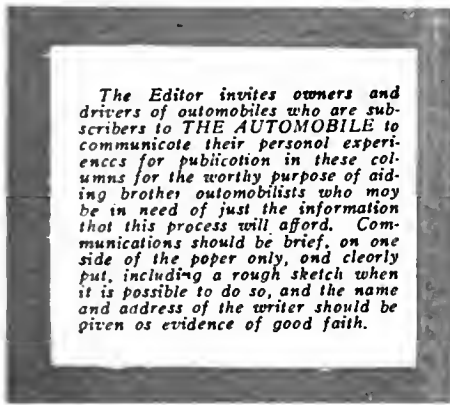

Fig. 1—Sections through a four-cylinder en bloc, V motor, showing a longitudinal and transverse section with the pistons, piston rods and three flywheels in their relative positions. P, piston; B, connecting rod; M, crank-pin; V, crank shaft; C, magneto; A, section of crank-pin

# What Other Subscribers Have to Say



trouble, but the tubes get pinched and nipped and I would like to know the reason for this. I pay particular attention when fitting a new tube not to let the lever come into contact with it. I should be obliged if you would give me a suggestion as to how to overcome this trouble. READER.  
New York City.

Your trouble may be caused either by the security belt or the bead on the casing. The tube T shown in Fig. 2 has been imprisoned by the security bolt S so that the latter cannot seat properly the bead. Or, when the car is turning a corner and the tire is not sufficiently inflated, the bead lifts from the rim R and pinches the tube T between the rim and the bead in the manner shown in Fig 3. Before attempting to replace the outer bead of the casing into the rim inflate the tube slightly and pass the hand inside the casing so as to be sure that the tube is not twisted or held under the security bolts. After the casing has been replaced the security bolts should be pushed up and down several times in order to make sure that they are free and seat properly.

## Starting with a Broken Crank

Editor THE AUTOMOBILE:

[2,757]—Would you kindly inform me through your columns of a method of starting a motor which has a broken crank. The crank is broken in such a way that it is impossible to use it and the machine was towed to a repairman. I would like to know if it would have been possible to start the engine without the crank?  
A. P. V.  
Albany, N. Y.

If the flywheel is accessible it may be turned over and the engine started. When doing this it is well to prime the cylinders through the pet-cocks. A rear wheel may be jacked up and turned over in a forward direction with the high gear thrown in. Still another way is to let the car run down hill or get some one to push it with the clutch disengaged until it gains momentum, the clutch is then thrown in. When the explosion occurs the clutch is disengaged until the motor gains speed.

## Interested In Sleeve-Valve Motors

Editor THE AUTOMOBILE:

[2,758]—I take the liberty of asking a question and would be pleased if you will give me a reply at an early date through the columns of your paper. On page 1056 of the issue of your magazine for December 22, 1910, you describe the Henriod four-cylinder rotary valve motor. Will you please explain by a sectional view of this motor the operation of the rotary valve, and also the auxiliary piston in the Berliet motor referred to in the next paragraph.  
Detroit, Mich. K. C. W.

The Henriod type of rotary valve is illustrated and described in another portion of this issue, and the Berliet auxiliary piston will be described at a later date in the near future.

## Wants Information on Marine Motor Design

Editor THE AUTOMOBILE:

[2,759]—Will you kindly give me the following information through your columns:

1. What should be the relative volume

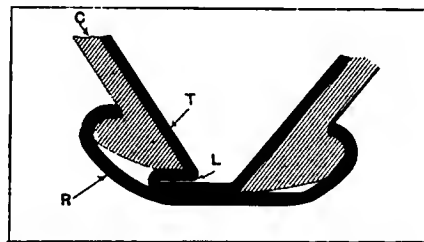

Fig. 3—Showing soft tire pinched by casing. C, casing; T, tube; R, rim; L, lap

of the compression space in a 10 x 10-inch gasoline motor for best and most economical working; or, in other words, what percentage of the volume should be left when the piston is at the highest point of the stroke?

2. I have an 8-cylinder 10 x 10-in. motor on a launch and am greatly troubled by premature firing. I believe high compression to be the cause. Do you think so?

3. What should be the length of stroke of a low-speed marine motor of this bore according to modern ideas? C. MORRIS.  
St. Louis, Mo.

1. For a compression of about 65 pounds, the total volume of the cylinder

would be about 31-2 times the clearance volume.

2. High compression is one of the causes of pre-ignition, but it is infrequent in a well-designed motor. For a slow-speed marine motor a compression of 65 pounds would be ample. To determine the amount of compression the spark plug should be removed and a bushing inserted; a pressure gauge can then be attached. The engine may then be turned up against compression and readings taken on the gauge.

3. A very flexible motor for marine work would be given by having a bore of 10 inches and a stroke of 13 inches.

## Compressing Spring on Clutch

Editor THE AUTOMOBILE:

[2,760]—I have removed the clutch from my machine and find that I cannot compress the spring. I would like to know of a method of compressing the spring, perhaps by means of some simple fitting which I will be able to attach myself, and if you could give me any advice on the same in your columns I am sure it would be of general interest.  
Grand Rapids, Mich. SUBSCRIBER.

A simple attachment which can be made in any shop, or by a blacksmith, is shown in Fig. 4. Around the collar of the clutch is placed a split clamp held together by two cross bolts. Passing through this clamp are two bolts about 3-8 of an inch in diameter sufficiently long so that the cross piece which is seen in the illustration touching the clutch spring, and which has two holes drilled in it, can pass over the bolts and allow sufficient room on the threads to start the nuts. With the aid of a wrench, the nuts can be alternately tightened until the spigot shaft passes sufficiently far outside the spring to permit the adjusting collar and nut to be screwed thereon.

The cross piece has to be drilled so that the shaft will pass through easily and sufficient to allow the nut to pass.

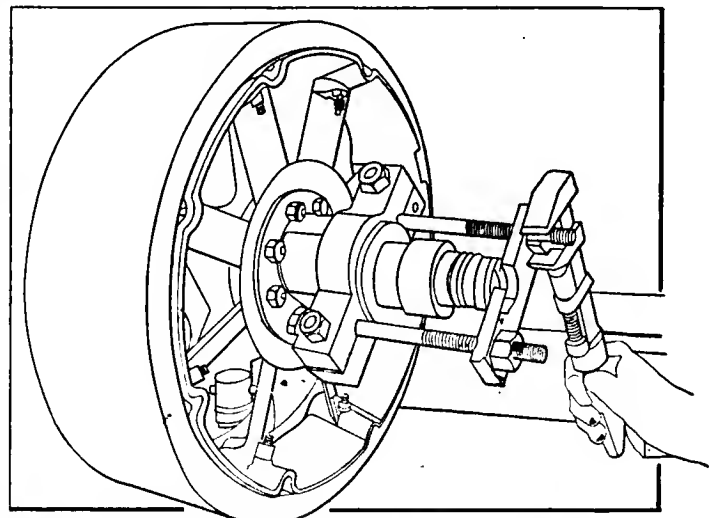

Fig. 4—Showing the method and tools used in compressing the clutch spring



# Meeting Recurring Troubles

## Presenting a Series of the Most Probable Cases

A series of correlated short stories, accompanied by diagrams and characteristic illustrations, including the nature of the troubles that are most likely to happen to automobiles, discussing their causes and effects, all for the purpose of arriving at a remedy. It is the aim for the most part to show how these troubles may be permanently remedied, and as a secondary enterprise it is indicated how the automobilist can make a temporary repair, thereby enabling him to defer the making of a permanent repair until a convenient time arrives.

**AUTOMATIC LUBRICATION ON THE PANHARD & LEVASSOR.**—The lubrication of the Panhard & Levassor twenty-horsepower valveless motor is done by means of both pump and splash. The oil is contained in the crankcase, which has a capacity of about 2 quarts when the oil is up to its proper working level. The oil is supplied to the crankcase by means of the breather pipes, which are equipped with strainers to insure a clean supply of oil to the crankcase.

The pump, which is driven off the camshaft, is of the plunger type and has a variable speed, which is entirely dependent upon the speed of the motor. The quantity of oil delivered, however, may be regulated by adjusting the length of the stroke of the pump plunger. The pump lifts the oil from the crankcase and forces it up through a sightfeed, which is located on the dash. After passing through the sightfeed the oil flows down into the splash troughs, which are located under each cylinder. In passing to these troughs the oil is led through the main bearings of the crankshaft and in this manner their lubrication is made positive. Another means of adjusting the quantity of oil supplied to the motor is furnished in the sightfeed itself, as the quantity of oil which passes through it may be governed and the excess will pass through a by-pass and back into the oil tank under the foot boards of the motor. The oil tank is connected directly to the pump by means of the suction pipe through which the oil is drawn on the first stroke of the pump. On the second stroke of the compound pump the oil is sent to the sightfeed.

After having passed into the splash troughs the oil will be picked up by the connecting rods and dashed into a spray. In case an excess of oil collects in the crankcase due to too much having been admitted from the sightfeeds it will be necessary to drain the excess from the base of the motor. For this purpose a drain, which may be opened by pulling a wire on the dash, has been installed. It is thus possible for a driver to drain the excess oil from the crankcase without leaving his seat.

There is a lead into the gear box which takes care of this part of the mechanism, while the transmission and differentials are taken care of independently by being packed in oil and grease.

**LUBRICATION OF THE 25-H.P. PAIGE-DETROIT.**—The Paige-Detroit car is lubricated by a simple splash system. The lower half of the crankcase is divided into two parts, the lower part forming the oil reservoir, while the upper carries the oil being used for the splash system.

The upper division of the oil pan casting is moulded so as to contain a series of troughs, one

below each cylinder. These troughs are deep enough to hold the oil into which the connecting rods dip at each revolution.

The oil is drawn from the lowest part of the crankcase by a plunger pump and forced through a sight-feed located on the dash. It then flows by gravity into the foremost splash chamber, drains over this into the next, and so to the last. When the oil level in the rear splash chamber becomes so high that it overflows the walls it passes down into the reservoir again. Then the oil is strained and passes again through the pump, which is driven off the camshaft.

The connecting rods dip into the troughs with such momentum that the oil is thrown in a spray up into the cylinders, lubricating their walls, as well as the connecting rod bearings and camshaft.

There are drain plugs in the bottom of the crankcase through which the oil may be drained out.

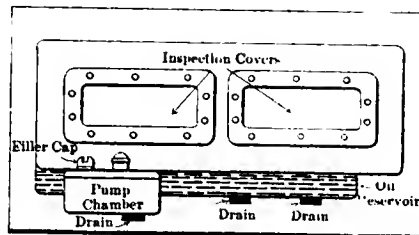

Fig. 2—Paige-Detroit crankcase, showing inspection covers on side of crankcase and location of oil reservoir

**THE MARION "40" LUBRICATION SYSTEM.**—The Marion 40-horsepower car is lubricated by a combination of the force-feed and the splash systems. The oil is forced by means of a pump to the main bearings. After passing through the main bearings and lubricating them, the oil drains down into the splash troughs, which are located in the crankcase in such a position that the connecting rods splash into the oil contained in them for a depth of about one-eighth of an inch.

The pump is located on the left-hand side of the motor. It is of the gear type and is driven off the camshaft. The pump draws its supply of oil from the crankcase reservoir, or, in case the oil level in this reservoir has fallen below the required amount, oil may be pumped to the pump chamber by means of a hand plunger pump which is located on the board just below the driver's seat.

The hand plunger pump draws the oil from an auxiliary tank in the rear of the car and forces it into the crankcase just under the pump chamber.

When about to start on a run the reservoir should always be filled to a fair level, the amount necessary, of course, depending on the length of the trip. The level of the oil in the crankcase reservoir may be observed by means of a gauge glass, which is set between the two middle cylinders on the top of the crankcase. The oil level should never be allowed to sink out of sight in this glass.

When the oil tank requires filling the top of the breather tube is removed and the oil poured through the screened opening in the pipe. It is a good plan to clean the screen immediately after the oil has been poured into the tank.

The entire interior of the motor is oiled by the oil mist which is present in the crankcase due to the splash of the rapidly revolving cranks into the oil in the crankcase partitions. This oil will flow back to a certain extent into the reservoir from where it is again passed through the system. Besides the cylinder walls, connecting rod bearings, etc., the camshaft, timing gears and water pump shaft are also lubricated by the splash.

There are grease cups located at various parts of the car. The differentials are packed in light grease, as are also the transmission and wheel bearing casings.

**COMBINATION SYSTEM OF THE MARION "30"**—The crankcase of the Marion "30" is divided into four sections, which form the splash troughs for

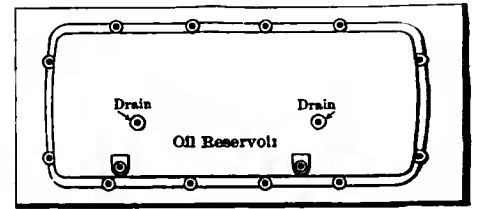

Fig. 3—Illustrating oil pan of the Marion "30," with drain plug and holt holes shown

the auxiliary oiling system. The main oiling system is a mechanical force-feed arrangement which is located at the highest part of the engine on the rear end. The mechanical oiler box is filled through a filler opening in the front end of the box by removing a cap. There is a gauze screen in the opening through which the oil is poured into the box. Before filling the tank the screen should always be taken out and cleaned with a little gasoline.

Besides the oil carried in the force-feed box there is a supply carried in the splash troughs in the crankcase. This part of the crankcase should be filled to the level of the top of the trough walls before starting on a trip, so that the cylinders will be lubricated by the splash as well as by the force-feed system.

The force-feed system is operated by an eccentric off the flywheel shaft. An eccentric rod runs from the eccentric up to a crank on the side of the oiler box nearest the dash. This crank drives a shaft which runs through the mechanical oiler and rests on a journal on the forward end of the box. There are three cams located on this shaft, each cam driving two oil pumps of the plunger type. The cams lift the pump plungers and allow them to fall suddenly over an edge of the cam. A spring attachment causes them to snap down; thus sending the oil, under pressure, down the six leads which are located beneath the box. Since there is a separate pump for each lead the amount of oil passing through each may be regulated according to the needs of the spot to which the oil is led. This regulation is affected by means of adjustment screws on top of the box.

There are three main bearings, but only one of them is supplied by oil from the mechanical oiler; this being the one nearest the flywheel. The others are oiled by means of the splash system. Four of the leads from the oiler box run respectively to the walls of each cylinder, and the remaining lead runs into the timing gear case.

The excess oil from all the bearings supplied by the force-feed system drains into the crankcase. In this manner the troughs are kept constantly full.

The connecting rods dip into the oil for a distance of about one-eighth of an inch and churn the oil in the crankcase up into a fine vapor.

**CIRCULATING SCHEME OF THOMAS CARS.**—The Thomas cars are lubricated by means of a circulating system which takes the oil from the reservoir and sends it through the oiling system. After use the oil is strained and used over again.

The reservoir is located in the crankcase and holds about two gallons of oil. The crankcase is arranged so as to have an inner and an outer bottom. In the outer or lower bottom the oil is carried, while the inner bottom is divided by partitions so that a trough is formed below each cylinder. There are three standpipes of elliptical section, so placed that in case the oil rises high enough to overflow the trough walls it will drain into these standpipes and by means of them into the oil reservoir below. The function of the troughs is to hold a sufficient supply of oil for the connecting rod caps to dip therein and churn the oil up into a vapor.

The pump which actuates the circulating system is of the plunger type. It takes the oil from the lower part of the crankcase and sends it through a three-glass sight feed and the three leads to the main bearings. The sight feed is located on the dash, and by its aid an accurate account of all the oil passing through the system may be had as well as a knowledge of the condition of the pump. The pump is driven off the cam shaft by means of a vertical shaft, spiral gears and an eccentric. It is contained in a brass casing which is held to the bottom of the motor base by cap screws.

After lubricating the main bearings the oil finds its way down into the splash troughs, from which it is picked up by the connecting rods and carried

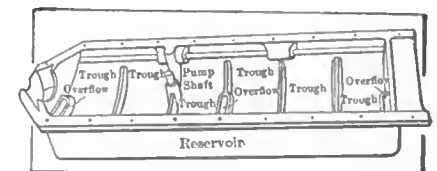

Fig. 4—Lower half of Thomas crankcase casting, illustrating disposal of splash troughs and overflow holes

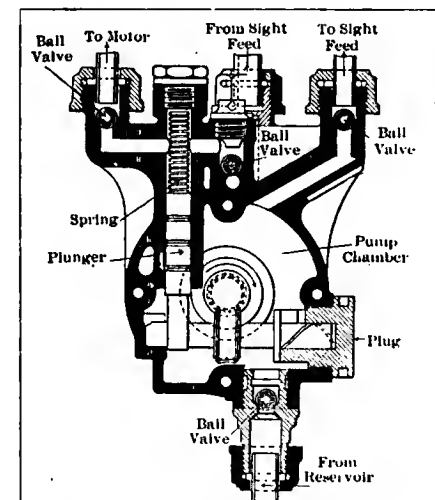

Fig. 1—Oil pump on Panhard & Levassor 20-horsepower valveless motor, showing leads, ball checks and plunger

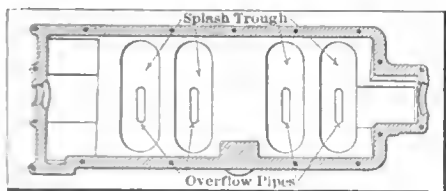

Fig. 5—Oil pan casting of Marion "40," showing overflow standpipes and oil troughs

to the other bearings. The oil through the standpipes drains back into the reservoir, but before entering into the suction end of the pump again, it passes through a strainer.

The reservoir is filled through the breather provided with a screen. The amount of oil present in the reservoir may be determined at any time by two try cocks provided for the purpose. The upper one is opened when filling the reservoir and oil is poured in until there is a flow of oil from it. The oil should never be allowed to run below the lower one. If it should reach the level of the lower try cock there is still enough oil in the tank for a run of about fifty miles, which will generally be enough to take the car to a place where more oil can be procured. The upper try cock is stamped FULL while the lower is stamped SAFETY.

The oil in this system should be thoroughly drained out about once a month and the crankcase flushed out with kerosene. To loosen carbon deposit the crankcase may be filled to the working level with kerosene and the motor run for about a minute in this condition. The other bearings throughout the car are taken care of by grease cups and oilers, while the differentials and transmission run in oil and grease.

**MECHANICAL OILER ON THE STEVENS-DURYEA.**

Stevens-Duryea cars are equipped with a mechanical oiler placed on the right-hand side of the crankcase at about the longitudinal center of the motor. This mechanical oiler carries the oil supply as well as a set of pumps which actuate the force feed. The mechanical oiler box has a capacity of five quarts and may be refilled by lifting the right-hand part of the engine hood and unscrewing the cap over the filler hole, which is on the front end of the box. When the cap is removed a screen is exposed through which the oil is poured, thus removing any foreign matter present in the oil.

Within the mechanical oiler box, which is placed so that the heat of the exhaust keeps the oil in a state of uniform temperature and consistency, there is a mechanically operated independent pump for each one of the leads through which the oil is forced to the main bearings. The pumps are driven from the layshaft by means of gears which drive a shaft in the oiler box. The small plunger pumps are driven in turn from this shaft, and the stroke of their plungers may be regulated anywhere from 0 to a full stroke. In order to determine exactly how much oil is being delivered from each pump it is only necessary to press down upon the bleeder valve caps while the engine is running. Oil will then drop from the bleeder valve nozzle into the tank instead of through the lead to the main bearings as it will do when the pressure is relieved. The plungers should be adjusted so as to give about two drops on each downward stroke, although when the car is new a little more oil may be of advantage until the bearings are worn to a smooth fit.

After the oil is forced by the plunger pumps to the main bearings it will lubricate them and drain into the crankcase, which is divided so as to have a compartment below each cylinder. A pool of oil will be formed in the compartment into which the connecting rod will dip at each revolution, thereby lubricating the moving parts in the entire crankcase.

Within each crankcase compartment there is a standpipe 1 1/8 inches in height. The oil should never be allowed to be above the level of the top of these standpipes, for then the motor will commence to smoke; for this reason the pumps in the mechanical oiler should be so adjusted that they do not give too much oil. At the bottom of each standpipe there is a cock which may be opened to let the oil flow out should it have accumulated to a height which is above the level of the top of the standpipe. If oil does not flow, however, it is not by any means a danger sign, as the motor will be amply lubricated if the pumps are each feeding two drops of oil on each downward stroke. Oil may be supplied directly to the crankcase if

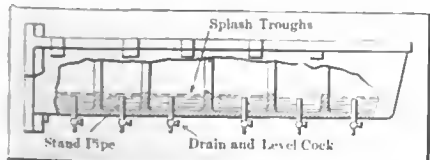

Fig. 6—Illustrating oil reservoir and drain and level cocks on Stevens-Duryea crankcase

necessary through the breather pipes. There are three of these, one to each pair of cylinders. They are equipped with screens.

About once a month the crankcase should be cleaned out with kerosene. This can be done by removing the petcocks under the base of the motor and filling to the usual level with kerosene oil. The motor is then started and allowed to run for about a half minute. The petcocks are then removed together with the drain plugs and the kerosene allowed to drain out. The plugs and cocks are then replaced, the latter being left open and oil is poured through the breathers until it starts to flow from the petcocks. The cocks are then shut off by turning the handles up.

The transmission case may be treated in the same manner, except that it is filled with about two quarts of heavy black cylinder oil.

**CIRCULATING SCHEME ON THE ROYAL TOURIST.**

The circulating system which is employed on the Royal Tourist motor is operated by means of a gear pump which is located in the reservoir which carries the oil supply. This reservoir is in the base of the motor and has a capacity of about two and one-half gallons. The pump is of the gear type and is driven off the camshaft. It takes the oil from the base of the motor and forces it up through a filter located on the side of the motor and easily accessible, so that the screens may be taken out and cleaned from time to time. The oil in the filter, which acts at the same time as a distributor, is under a pressure of about two pounds. The pressure in the filter and distributor may be easily determined by means of a pressure gauge which is located on the dash. Special care has been taken to perfect this filter, and it is constructed so as to be composed of alternate layers of filter paper and metal disks.

There are two leads from the filter, one of which passes directly to the timing gear case, and the other passes up to a sight feed, at which point the oil is divided into three parts and passes through three separate sight glasses. Each of these sight glasses leads directly into a lead to

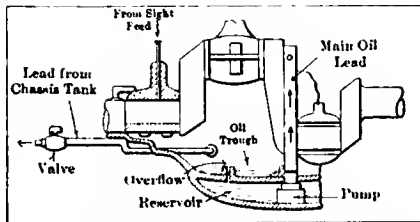

Fig. 7—Showing circulating system on Royal Tourist motor and the lead from auxiliary chassis tank

a main bearing. The main bearings are lubricated by the oil which passes through these leads, the oil then draining down into the splash troughs which are placed so that there is a trough below each cylinder.

The oil drains from the main bearings at a rate which is rapid enough to keep the troughs constantly full and overflowing. The overflow of the splash troughs is taken care of by a series of standpipes which are placed one in each trough. These standpipes are of such a height that when the oil reaches the top it is of just such a height that the connecting rods will dip to a proper depth into the oil contained therein. The rapidly revolving connecting rods churn the oil into a mist which entirely pervades the crankcase and lubricates all the moving parts which are located within the confines of this casting.

To make the lubrication more certain there is an oil catch on the crank cheek which catches the oil and by centrifugal force sends it through a lead drilled in the crankshaft up into the crank pin. The bearing at the crank-pin end of the connecting rod will be lubricated by the oil which flows through the duct in the pin, and in addition the oil is sent up along the connecting rod through a small tube to the wrist pin. With this system there is a forced feed to the three crankshaft bearings and to the bearings at the ends of the connecting rods.

Should the pressure at any time mount too high there is a safety valve controlled by a spring which allows the oil to by-pass into the timing gear case. The supply of oil through the main leads may be governed by means of this safety valve. To increase the supply of oil delivered to the main bearings, the nut which controls the tension on the spring which

holds the ball check in the safety valve is given a turn or two to the left, thus releasing the tension on the spring. To decrease the supply of oil the procedure is, of course, directly opposite.

Besides the supply of oil which is carried in the crankcase there is an auxiliary supply carried in a three-gallon chassis tank located under the floor boards. Between the tank and the lower part of the crankcase into which the pipe from the tank is led a valve is inserted so that the supply of oil in the crankcase may be augmented at will.

The other bearings on the car are taken care of in the usual manner by means of grease cups, while the transmission and differentials are packed in oil and grease.

**ADJUSTABLE TROUGHS ON THE DAIMLER.**

The Daimler cars are lubricated by the splash system. The oil reservoir, which has a capacity of about two gallons, is located in the lower part of the crankcase. The crankcase casting is in the form of a basin with an inner and an outer bottom. In the lower or outer bottom the oil supply is carried, while the inner bottom, which in this car is not an integral part of the crankcase casting, is an adjustable tray capable of a perpendicular motion. Upon this inner bottom or tray rest the splash troughs into which the oil flows while the lubricating system is in operation.

The oil starts originally from the bottom part of the crankcase in which the whole available supply of oil is carried, and passes up into the line of splash troughs and then overflows back to the reservoir in the bottom. This process of circulation requires of necessity some outside force to carry the oil through the system, and this is furnished by means of an oil pump. This pump is of the plunger type and is driven off the camshaft by means of an eccentric and rod, which extends vertically down into the base of the motor on the right-hand side, being enclosed, however, by the crankcase so that it is in itself lubricated by the splash of the connecting rods into the above-mentioned troughs.

The pump lifts the oil from the crankcase reservoir and forces it into the main oil lead, which is a pipe running around the inside of the crankcase. This pipe is perforated at the forward end of the crankcase so that it permits the oil to drop into the foremost trough. The oil is constantly being fed from the pump, so that it will soon overflow the first trough and find its way back until all the four troughs are completely filled and overflowing.

The connecting rods dip down into the oil and beat it into a mist which is present in all parts of the crankcase in sufficient quantities to lubricate all the moving parts therein. This includes the pistons, connecting rod bearings, camshaft bearings and the pump eccentric rods as well as all the crankshaft bearings. The pump, since it is operated from the camshaft, will bear a relative speed to the motor itself, that is, the greater the number of revolutions per minute made by the motor the greater the number of strokes per minute made by the pump plunger. This takes care of the speed of the car, but does not automatically take cognizance of the heavy duties laid upon the motor in moving slowly up a steep hill. To take care of this an arrangement is made whereby the connecting rods dip more deeply into the splash troughs and hence throw more oil up into the heated cylinders. A motor will have great tendency to heat up in running up a hill owing to the open throttle and late spark. In this way the mixture is not only rich, but the late spark tends also to overheat the motor. A rod, which runs longitudinally within the crankcase, is jointed to the tray which carries the splash troughs, so that when it is turned by means of the regulating levers the tray is lifted and in this manner the connecting rods are bound to get more oil. Besides acting as a lubricant, when the oil is copiously supplied, as it will be when adjusted in this manner, it also acts as a liberal cooling agent.

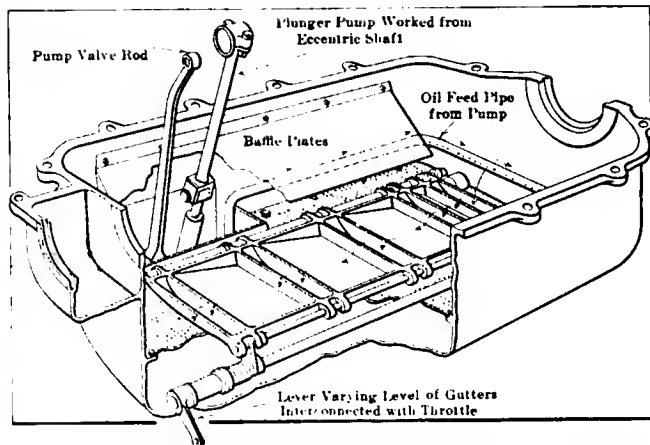

Fig. 8—Sectional view of adjustable splash gutters in use on English Daimler cars. The pump rods and eccentric are also shown

## Making Wooden Chassis Frames

*The making of the wood sill is an important operation in the plant of the H. H. Franklin Manufacturing Company, which features this form of construction, having used and developed it from the time it first began to build its air-cooled cars thirteen years ago.*



Fig. 3—Screwing the laminations of the sill together

THE study of wood for the manufacture of sills and the results obtained have not attracted the widest attention in the automobile world, due to the fact that the majority of cars are built with steel rather than wood and that there are few wood chassis frames outside the line of the H. H. Franklin Mfg. Co.

The course of a piece of timber which is designed to become a part of one of these sills is hedged about with as much watchfulness as is that of a piece of high-grade steel. From the very beginning the

wood is carefully chosen. It is all ash of second growth.

This is selected because it is of better grain than first growth and is more adapted to the service requiring strength, resiliency and lightness. Most of that used at present is taken from northern Pennsylvania. Southern ash is too brash. The stock is carefully selected. The second-growth ash used is about 16 feet long and is 1-inch stock.

After being shipped to the factory it is stored in a yard to season for two years after which time it is ready to be used.

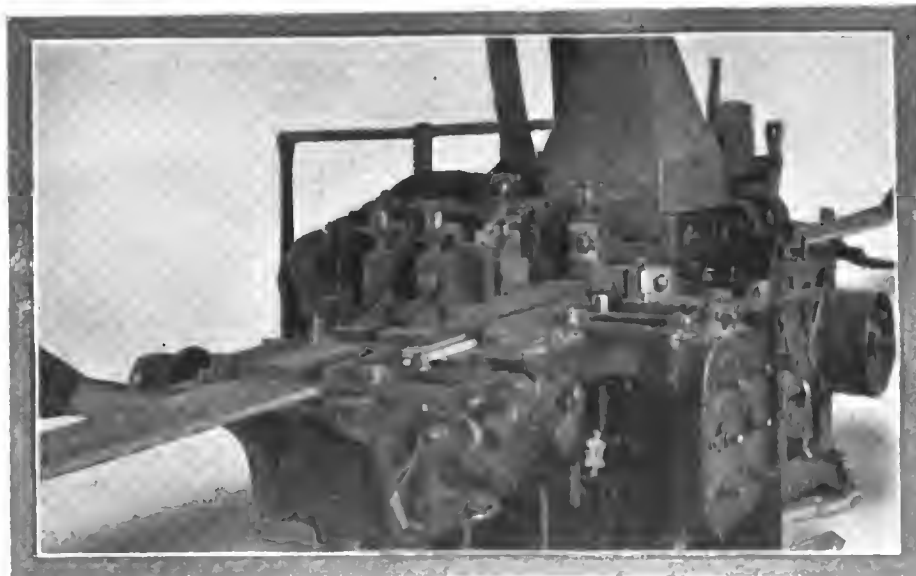

Fig. 1—Showing the process of planing the sill-shaped pieces after kiln-drying

When it has been thoroughly weather seasoned it is taken to the sawmill and, after being marked with a form, is sawed up into sill-shaped pieces. These are given a short kiln drying to increase their resiliency and render them less susceptible to weather conditions. From the kiln the pieces go to the wood shop where they are planed.

This operation is shown in Fig. 7.

Some are planed thinner than others, and the next move consists in sorting out two thick sections and one thin section, the latter being the middle ply of the three-lamination sill. The outer layers are left thicker at this point as yet more planing and trimming which in the end leaves the three laminations the same thickness. These three sections are painted with glue and are fastened together with clamps applied in close proximity to each other, the whole operation being clearly indicated in Fig. 2.

The gluing is generally done late in the afternoon, and the clamps are allowed to remain in position until the following morning, causing the glue to "set." Then after more jointing and planing the sill is marked, band-sawed and shaped on a former. This leaves it the size desired for use.

Being made of three layers of wood, precaution is taken lest water or the weather affect the serviceability of the pieces by working into the glued joints at the top and bottom. Along the top and bottom of each sill is fastened a strip of ash 3-16 of an inch thick. The three laminations are next fastened together with screws, making the three-ply sill stronger than it would be were it a whole piece of the same size. The thickness of the completed sill is 1 3-4 inches. The screwing operation is shown in Fig. 3.

To provide for the rear cross bar, the sills are put through a forming machine which cuts a right angle section from the rear end of each, permitting the insertion of the cross bar ends. Holes are next bored for the emergency brake band lever, and then the sill goes to its assembly.

Bench workmen, who perform this task, clean the sill and round up the top and bottom edges. The top corners are rounded with a radius of approximately 1-16 of an inch while the bottom corners are rounded with a radius of 1-8 of an inch. This is because the larger radius is more serviceable in its position while the 1-16 of an inch radius is more pleasing to the eye.

The front end of each sill is covered with an aluminum cap. The rear corners are strengthened by a block 1/4 x 4 x 4 1-2 inches, glued and screwed inside the angle.

In assembling the forms the work is carried on a "trestle." The floor boards, very small iron attachments, etc., are put in place here.

Workmen are not troubled with measuring for the location of holes, all this being done with a templet. In boring, certain positions of the frame on the "trestle" give the correct angle for the holes. The glue used in this work is an imported French sheet glue.

The length of sills for models H, D, M and G, is, respectively: 162 1-4 inches, 147 1-4 inches, 129 inches and 119 inches.

The rear ends of the sills are thicker vertically than are the front ends, although the difference is but a slight fraction of an inch. The thicknesses at the rear end for models H, D, M and G are respectively: 4 inches, 4 3-16 inches, 3 31-32 inches and 3 3-4 inches.

For these same models the measurements at the center of the sill, which point is thickest vertically, are 7 inches, 6 1-2 inches, 6 1-2 inches and 5 3-4 inches.

The reason put forward for using a wood sill or frame on the Franklin cars is because it is stronger and lighter and also because its capacity for absorbing vibrations and road shocks is very much greater than that of steel. There are quite a few comparative uses for wood that are somewhat similar under certain conditions and which should be stated in arguing for the advantages of a wood sill. For instance, one of the greatest articles used in impact is the hammer, and all of these have wooden handles. If one were to put a steel handle in one of these hammers a great difference would be noticed in the effect on the human body of a blow.

Another very apt illustration is a steam hammer. Whereas a steam hammer of itself is set on a concrete foundation the anvils of practically all steam hammers used in steel mills and such places are set up on wooden foundations.

In support of the contention that this laminated-ash frame is lighter and stronger than steel a number of tests were made in the Franklin factory. Pieces of ash 4 inches wide and 2 inches thick were obtained. They were as follows: solid piece, 2,370; thoroughly seasoned, laminated piece, 2,500; laminated piece, sap wood material, 1,950. It is thus seen that the thoroughly seasoned, well glued piece of ash wood was the strongest of the three sorts tested.

At the same time tests were made of channel steel of the same comparative size as would be used in making a chassis frame of the size for which the wood pieces are used. Low carbon and



Fig. 2—Clamping the three laminations together after they have been glued

chrome nickel steel were used. In no case did the unit weight load get above 1,550 pounds whereas it went as low as 625. The piece which gave the 1,550 pounds unit weight load weighed 12.25 pounds, and was 4 1-2 inches high, 1 13-16 inches wide and was 2-10 of an inch thick, while the strongest piece of ash weighed but 6.25 pounds

The steel tested was what would probably be used in making a chassis frame and on this comparison, which was actually the best, the engineers were able to show that the laminated wood sill was about 65 per cent. stronger and weighed 50 per cent. less.

# Calendar of Coming Events

## Handy List of Future Competitive Fixtures

### Race Meets, Runs, Hill-Climbs, Etc.

- July 20-28.....Minneapolis Reliability Run, Minnesota State Automobile Association.
- July 29.....Cincinnati, O., Hill Climb, Cincinnati Automobile Dealers' Assn.
- July 29.....Philadelphia, Track Races, Point Breeze, Quaker City Motor Club.
- July 29.....Richmond, Va., Reliability Run, Richmond *Virginian*.
- Aug. 3-5.....Galveston, Tex., Beach Races, Galveston Automobile Club.
- Aug. 7.....Chicago, Ill., Commercial Reliability Run, Chicago *Evening American*.
- Aug. 8.....St. Louis, Mo., Reliability Run, St. Louis Automobile Mfrs' & Dealers' Assn.
- Aug. 12-18.....New Orleans-to-Memphis Good Roads Tour, New Orleans *Picayune*.
- Aug. 12.....Philadelphia, Reliability Run, Quaker City Motor Club.
- Aug. 12.....Worcester, Mass., Hill Climb, Worcester Automobile Club.
- Aug. 17.....St. Louis, Mo., Reliability Run, Missouri Automobile Assn.
- Aug. 25-26.....Elgin, Ill., Stock Chassis Road Race, Chicago Motor Club.
- Aug. ....Cheyenne, Wyo., Track Races, Cheyenne Motor Club.
- Sept. 1.....Oklahoma, Reliability Run, *Daily Oklahoman*.
- Sept. 2-4.....Brighton Beach, N. Y., Track Races.
- Sept. 4.....Denver, Col., Track Races, Denver Motor Club.
- Sept. 7-8.....Philadelphia, Track Races, Philadelphia Auto Trade Association.
- Sept. 7-9.....Hamline, Minn., Track Races, Minnesota State Automobile Association.
- Sept. 7-10.....Buffalo, N. Y., Reliability Run, Automobile Club of Buffalo.
- Sept. 12-13.....Grand Rapids, Mich., Track Races, Michigan State Auto Association.
- Sept. 15.....Knoxville, Tenn., Track Races, Appalachian Exposition.
- Sept. 16.....Syracuse, N. Y., Track Races, Automobile Club and Dealers.
- Sept. 18-20.....Chicago, Ill., Commercial Reliability Run, Chicago Motor Club.
- Sept. ....Brighton Beach, N. Y., Twenty-four-Hour Race.
- Sept. ....Denver, Col., Track Races, Denver Motor Club.

- Sept. ....Detroit, Mich., Reliability Run, Wolverine Automobile Club.
- Sept. ....Steubenville, O., Hill Climb, Automobile Club of Jefferson Co.
- Oct. 3-7.....Danbury, Conn., Track Races, Danbury Agricultural Society.
- Oct. 7.....Philadelphia, Fairmount Park Road Races, Quaker City Motor Club.
- Oct. 9-13.....Chicago, Ill., Thousand-Mile Reliability Run, Chicago Motor Club.
- Oct. 13-14.....Atlanta, Ga., Track Races.
- Oct. 16-18.....Harrisburg, Pa., Reliability Run, Motor Club of Harrisburg.
- Nov. 1.....Waco, Tex., Track Races, Waco Auto Club.
- Nov. 2-4.....Philadelphia, Reliability Run, Quaker City Motor Club.
- Nov. 4-6.....Los Angeles-Phoenix Road Race, Maricopa Auto Club.
- Nov. 9.....Phoenix, Ariz., Track Races, Maricopa Automobile Club.
- Nov. 9, 11, 12.....San Antonio, Tex., Track Races, San Antonio Auto Club.
- Nov. 27.....Savannah, Ga.—Vanderbilt Cup Race, Savannah Automobile Club.
- Nov. 30.....Los Angeles, Cal., Track Races, Motordrome.
- Nov. 30.....Savannah, Ga., Grand Prize Race, Savannah Automobile Club.
- Nov. ....Columbia, S. C., Track Races, Automobile Club of Columbia.
- Dec. 25-26.....Los Angeles, Cal., Track Races, Motordrome.
- Date indef.....Port Jefferson, L. I., Hill Climb, Port Jefferson Automobile Club.
- Date indef.....Riverhead, L. I., Road Race, Port Jefferson Automobile Club.

### Foreign Fixtures

- Aug. 6.....Mont Ventoux, France, Hill Climb.
- Sept. 2-11.....Roubaix, France, Agricultural Motor Vehicle Show.
- Sept. 9.....Bologna, Italy, Grand Prix of Italy.
- Sept. 10-20.....Hungarian Small-Car Trials.
- Sept. 16.....Russian Touring Car Competition, St. Petersburg to Sebastopol.
- Sept. 17.....Semmering, Austria, Hill-Climb.
- Sept. 17.....Start of the Annual Trials Under Auspices of *l'Auto*, France.
- Oct. 1.....Gailion, France, Hill-Climb.
- Oct. 12-22.....Berlin, International Automobile Exhibition.





Vol. XXV Thursday, July 27, 1911 No. 4

THE CLASS JOURNAL COMPANY

H. M. SWETLAND, President
A. B. SWETLAND, General Manager
231-241 West 39th Street, New York City

EDITORIAL DEPARTMENT

THOS. J. FAY, Managing Editor
GEORGE M. SCHELL, Associate Editor
JAMES R. DOOLITTLE HUGH P. MacCONNELL
HANS WEYSZ

ADVERTISING DEPARTMENT

W. I. RALPH, 1035 Old South Bldg., Boston
C. H. GURNETT, 1910 South Michigan Avenue, Chicago
L. G. VOGEL, Avenue, Chicago
T. B. VAN ALSTYNE, New York and Phila.
H. L. SPOHN, New York
LOUIS R. SMITH, New York
FRANK B. BARNETT, 309 Park Building, Cleveland
H. H. GILL, 627 Ford Building, Detroit

Cable Address - Autoland, New York
Long Distance Telephone - 2046 Bryant, New York

SUBSCRIPTION RATES

United States and Mexico - One Year, \$3.00
Other Countries in Postal Union, including Canada - One Year, 5.00
To Subscribers—Do not send money by ordinary mail. Remit by Draft, Post-Office or Express Money Order, or Register your letter.

FOREIGN SUBSCRIPTION AGENTS

ENGLAND:—W. H. Smith & Sons, Ltd., 186 Strand, London, W. C., and all book-stalls and agencies in Great Britain; also in Paris at 248 Rue de Rivoli.
FRANCE:—L. Baudry de Saunier, offices of "Omnia," 30 Rue Duret, Avenue de la Grande Armee, Paris.
GERMANY:—A. Seydel, Mohrenstrasse 9, Berlin.

Entered at New York, N. Y., as second-class matter.

The Automobile is a consolidation of The Automobile (monthly) and the Motor Review (weekly), May, 1902, Dealer and Repairman (monthly), October, 1903, and the Automobile Magazine (monthly), July, 1907.

NOTHING is more convincing of the broad worth of the automobile for transportation purposes than the illustrations that are given in the leading story of THE AUTOMOBILE of this issue. These illustrations show by comparison the roads that are devoted exclusively to automobile service, alongside of the roads that entertain horse-drawn vehicles. The roads that are used exclusively by automobiles are sanitary and smooth in the examples given, whereas the roads that are used by horse-drawn vehicles are anything but sanitary, nor are the surfaces smooth. These examples of roads under the set of conditions named are in the nature of positive proof of the lack of acumen and understanding of the men who deprecate the use of automobiles and the elimination of horse-drawn vehicles. It is no longer possible for health officials to carry conviction among intelligent men unless they put themselves on record in favor of banishing horses from the streets of cities, and any argument on the part of road builders that has for its foundation the idea that automobiles have a more marked bearing upon the upkeep of roads than have horses must fall to the ground of its own weight.

\* \* \*

STATISTICS, as they relate to the maintenance of freight automobiles, lose much of their force, due to lack of discrimination of the compilers thereof, who fail to take into account the advances that have been made in gasoline freight automobile building within a year or two. Freight automobile service has been developed in

the City of New York to a greater extent, perhaps, than in any other metropolitan center in this country, and in estimating the relative value of types of freight automobiles, account must be taken of the fact that gasoline freight automobiles were barred from docks and warehouses by the unfair rulings of insurance interests, thus making it extremely difficult for the builders of freight automobiles to show the capabilities of their products. The abrogation of these rules has had the effect of improving these freight automobiles and showing to merchants just how capable they are in every-day work.

\* \* \*

GLANCING at the descriptions of motors other than the poppet-valve type, as they are being described in THE AUTOMOBILE, makes it possible to entertain the idea that the United States Patent Office is being inundated with patent applications along these lines, and we are confronted by the rather poor methods that at present obtain in the Patent Office in handling these matters. It is now the common understanding that the unfortunate inventor who receives Letters Patent of the United States in recognition of a service will have to view such Letters Patent in the light of punishment rather than in the form of protection, according to the theory of patent law. If a man who is the owner of a patent, wishing to protect himself against infringers, calls upon his attorney for the purpose of getting advice reflecting a fair measure of his rights and reasonable expectations in the event of an action, he is likely to be told that there is no possible way by which an attorney can gauge the possibilities, and that the merits of actions-at-law involving the rights of inventors are too obscured to offer any reward from discussion. If it takes the large force of examiners under the Commissioner of Patents, aided by all the patent attorneys in this country, to produce the chaos that obtains in patent matters, it may not be too much to say that the clearing up of this muddle is far beyond the ability of any man to suggest.

\* \* \*

DELIVERING packages in department store service, if the cost per package is to be reduced to the actual minimum, requires that the freight automobiles in this work shall be designed according to the needs as indicated by the best expression of experience. It seems to be true that a freight automobile of considerable capacity carrying a large number of packages, utilizing even ten or twelve runners, is superior to a delivery wagon utilizing the services of a driver and one runner, due to the fact that the boys who serve as runners are swift and tireless, and the large-capacity freight automobile is permitted to traverse a main avenue at a fairly good rate of speed, while the boys who serve as runners take the packages from this freight automobile, delivering them to residences within a radius of 500 feet on both sides of the main avenue, at a saving in the first cost of the freight automobiles used, a considerable saving in wagon maintenance, and with a large reduction in the cost of labor required in the service. Modifications of the main plan must be made, depending upon the locality and attending details, but the fact remains that the trend in this field is in the direction of freight automobiles of considerable tonnage, rather than in the use of light delivery wagons.



# Fortune for Motor Fire Engines

## New York to Spend \$700,000 for Apparatus

*By order of the Fire Commissioner a board consisting of four well-known members of the department has been formed to take up the subject of completely motorizing the fire department of New York. The committee, which is now in session, is charged to examine and test all available makes of engines and at present there is a vast sum available for purchases. It is expected that the department will be fully modernized in two years.*

VIGOROUSLY advocating the purchase and installation of automobile fire-fighting apparatus, the Fire Commissioner of New York has named a special board from among the technical officers of his department to examine, test and report upon the various types of apparatus available for this purpose. This board consists of Deputy Commissioner Farley, of Brooklyn; John Kenlon, Acting Chief of Department; Chief John P. Howe, and Captain Charles Demarest.

The board is now in session preparing for the details of actual work. So far about a dozen different kinds of fire engines propelled by gasoline motors have been considered, and when the list is complete it is believed that between 40 and 50 different makes will have been tested. Manufacturers have been invited to submit data to this board and a vast mass of material of that sort has been sent in or personally submitted.

The requirements of the department are severe and the tests that have been conducted have been exceedingly searching. It is believed by those in the best position to know that the complete motorization of the department will require about two years. Last spring it was thought that it would take about four years to displace every piece of horse-drawn apparatus.

At present the amount of money available for this purpose is \$700,000, and this will be increased when needed for actual expenditures. It was announced at headquarters on Wednesday that the work of the board could hardly be completed before the end of this year, but that much would be accomplished in the meantime looking toward this end.

The experience of the New York fire department with automobile apparatus so far has been satisfactory and at this time it is said that there are over 40 pieces of mechanism now being built for the department or in course of transit from the factories to New York.

### Thompson Avenue Grade Scores Again

Another automobile was smashed on the Thompson avenue grade crossing of the Long Island Railroad Monday, snuffing out the life of the driver of the car and severely injuring two women. The Thompson avenue crossing is a nightmare to the automobilist of New York. It is on the main artery of travel toward the interior of Long Island, north of the regular routes through Brooklyn proper.

The busiest section of the railroad is traversed by the road at grade, the crossing being a maze of steel tracks. There are gates on each side of the right of way, and at almost any hour of the day or night automobiles may be found lined up on both sides of the crossing waiting their chances to scurry across between the silently rushing trains.

In the busy hours of the day the automobiles are frequently obliged to wait for a half hour to cross.

The Long Island Railroad has always taken a great interest

in automobiling, and it has been active in a legislative way to "regulate" automobile traffic so that it might not prove too attractive to possible commuters.

In the case of this accident three cars were crossing when a train bore down upon them while the gates were raised, the way apparently clear and safe.

It is stated that 352 trains pass the crossing every weekday. A contract has just been entered into between the city and the railroad to abolish this and other crossings and the city's portion of the expense is to be \$600,000.

### Jersey Kills Eight-Day Permits

Perfectly consistent with its action in closing the doors of the State to free touring, New Jersey has now abrogated the eight-day touring license that has served instead of a more generous provision. Commissioner of Motor Vehicles J. B. R. Smith has made the announcement that the eight-day provision is no longer in effect and already a howl has been raised by automobile owners in New York, which has an echo in the hearts or pocketbooks of the hotel owners along the Jersey coast.

In substance the Legislature at its recent session declared that Jersey does not want automobile tourists, despite the piercing cries of disapproval from the hotel men. By its refusal to pass reciprocal legislation the lawmakers place themselves on record as forbidding the free entry of the State to automobiles that have complied with the laws of their home States, unless their owners took out full touring licenses for the year.

The injustice of such action is made apparent when it is realized that there are no such strictures placed upon traffic other than that represented by the automobile. Officials of the A. C. A. have taken up the matter with Commissioner Smith, and the announcement is made that all hope of some mitigation of the order has not been abandoned.

H. A. Bonnell, general manager of the A. B. of T., who is a leading member of Jersey motordom, says he is heartily disgusted with the trend of events and sees little hope for amelioration of conditions in the immediate future.

### Rules for N.A.A.M. Show

Rules to govern the Twelfth Annual National Automobile Exhibition, which will be held at the Grand Central Palace, New York, January 10-17, 1912, have been issued. These provide that exhibitors at unsanctioned shows shall be barred. The main and second floors of the building will be used for pleasure car displays and the wall spaces for the commercials. Accessories will be displayed on the third floor. Price of space is \$1.25 a square foot. One-half of the net proceeds will be rebated to exhibitors. General admission will be 50 cents.

### Blue Book Crew Finds Good Roads

BANGOR, ME., July 24—The Blue Book automobile now touring in upper New England had a busy time last week. The car was driven from New York to New Haven, to Hartford, Springfield, Pittsfield, Greenfield, Brattleboro, Keene, Nashua, Portsmouth, Boston, Concord and the White Mountains.

Good roads were encountered everywhere except between Greenwich and Norwalk and Nashua and Concord and a few short stretches in various places.

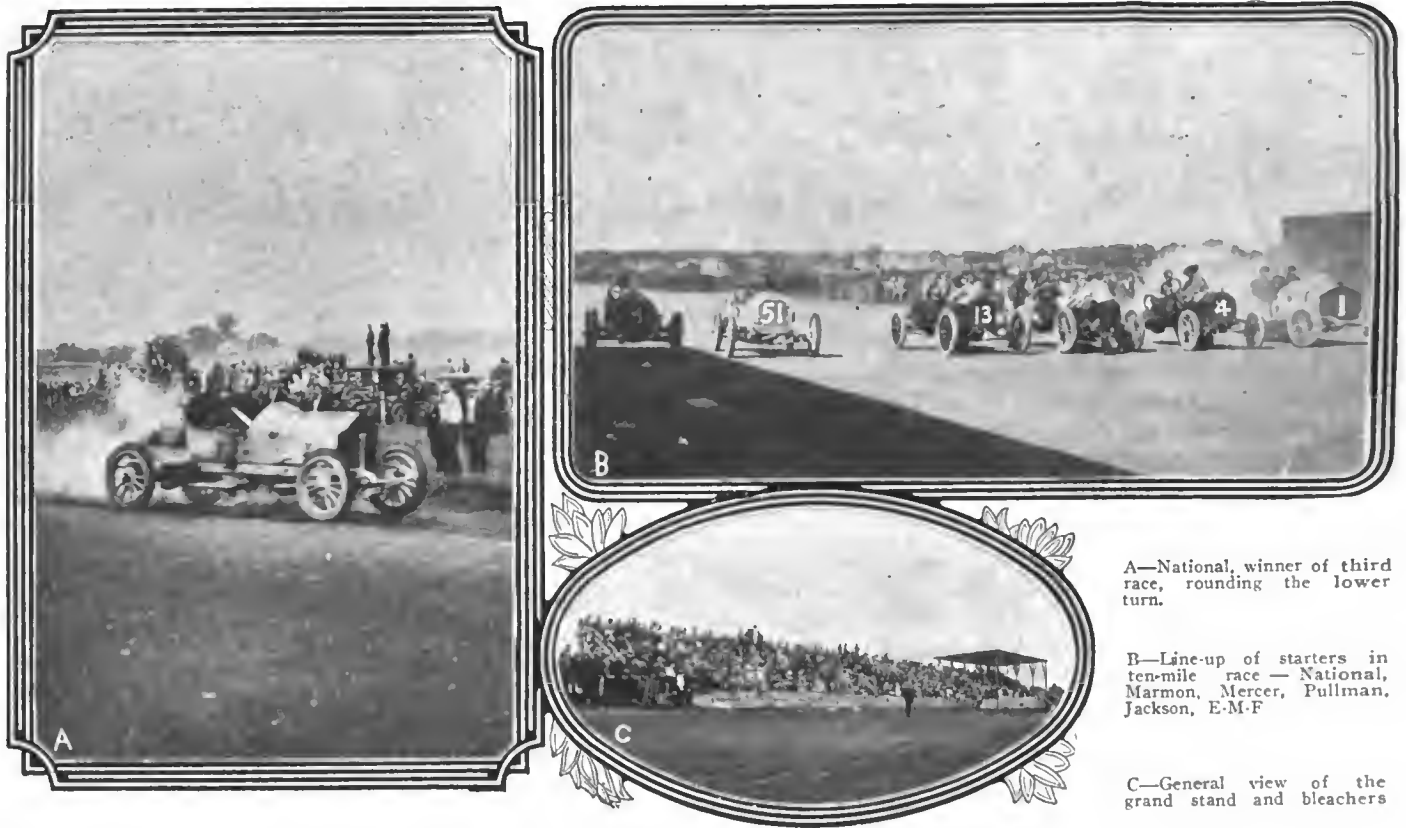

A—National, winner of third race, rounding the lower turn.

B—Line-up of starters in ten-mile race — National, Marmon, Mercer, Pullman, Jackson, E-M-F

C—General view of the grand stand and bleachers

## Ten-Mile Track Mark Lowered

### Guttenberg Crowd Sees New Record Made

*A big half-holiday crowd attended the Guttenberg race meeting on Saturday and saw a Simplex car set a new mark for the ten-mile distance, and then in the next race witnessed the same car knock a dozen seconds from its own speed record. The races were rather tame from the contest point of view and in only one of the six events run off was there anything that looked like a struggle. This came in the 451 cubic inches class and the winner, a National, after being left at the post and pocketed for several miles, worked its way through to win rather easily.*

**T**HERE were no thrills about the racing at Guttenberg last Saturday, the program failing to develop anything spectacular. But on the other hand there was nothing that savored of mishap during the afternoon's sport and the big crowd saw the ten-mile record of the track lowered in two successive races. A 50-horsepower Simplex was the medium and after setting the new mark for the distance at 10.43 3-5 in its class race, it knocked off over 12 seconds from that time in the Free-For-All, placing the new track mark at 10.31 1-5, which will not be disturbed for some time in all probability.

There were five events carded and a match race was added and the number that created the most interest in the evening was third on the program.

In this race four cars were entered and two added at the post. National No. 1 proved to be the winner after being practically left at the post. The Marmon entry jumped away at the start

and opened up a comfortable gap in the first three miles, followed by the E-M-F and Mercer. The latter was going well at five miles but seemed to develop some trouble with its carbureter in the latter stages and could not get up enough speed to stay with the leaders. The National started last and was in a deep pocket for several miles, but along toward the eighth mile it began to loom up like a winner and gradually worked through to the front, not being pushed at the end. The Marmon apparently had the race won at one stage but faltered in the last mile, lasting long enough to get the place from the Mercer, which acted stiff and did not respond to De Palma's urging. This car was not properly tuned up before the races.

The first race was a small class event and was won all the way by the E-M-F entry, the Paige-Detroit being in closest attendance at the finish. The second race was also taken by the E-M-F, which beat the gun and made the pace from end to end. The Pullman was second all the way.

The match race was a procession with the Staver leading the way.

In the big class event the National beat the gun rather flagrantly but was soon overhauled by the Simplex and the rest of the race was uninteresting save for the fact that a new mark for the distance on this track was established only to be overthrown in the next race by the same car. The National was second, Marmon third, and the Jackson blew a tire and did not finish.

In the Free-For-All there was nothing to it but the Simplex which got away with the leaders and outfooted the field. As in the preceding event the National was second and the Marmon

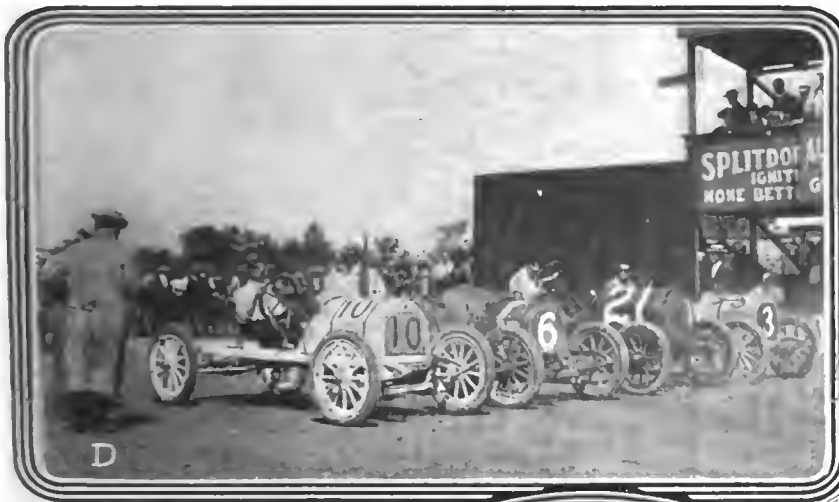

D

D—Line-up for the five-mile "under 231" race—E-M-F, Overland, Lancia, Paige-Detroit

E—There was a goodly turnout of cars and railbirds



E

F—Staver winning the five-mile match race



F

third. The Pullman and Staver contestants did not figure in the running. Limberg was sharply cautioned by Referee Camacho for beating the gun but was not set down.

The track looked as if it needed oil and it certainly was helped materially by the rain of the night before. The club house and the far turns were in bad shape after the first three races had been run and T. B. Shoemaker of the Contest Board made an inspection. He cautioned the drivers to observe special caution in rounding them. A. F. Camacho handled the flags and acted as referee and gave satisfaction. It is estimated that there were between 3,000 and 4,000 present. The summary:

Five Miles Class E Under 231 Inches				
No.	Car.	Driver.	Position.	Time
3	E-M-F.	Tower	1	5:47%
10	Paige-Detroit	Craig	2	
6	Lancia	Ferguson	3	
21	Overland	Gastieges	No finish.	
Five Miles Class E Under 301 Inches				
3	E-M-F.	Tower	1	5:38%
13	Pullman	Burke	2	
10	Paige-Detroit	Craig	3	
8	Correja	Gillam	4	
23	Staver-Chicago	Du Closne	5	
6	Lancia	Ferguson	6	
7	Mercer	De Palma	No finish.	
Five Miles Match				
23	Staver-Chicago	Du Closne	1	6:40%
50	Correja	Gillam	2	
Ten Miles Class E Under 451 Inches				
1	National	Limberg	1	11:13%
4	Marmon	Rouse	2	
7	Mercer	De Palma	3	
13	Pullman	Burke	4	
51	Jackson	Cobe	No finish.	
3	E-M-F.	Menges	No finish.	
Ten Miles Class E Under 601 Inches				
2	Simplex	De Palma	1	10:31%
1	National	Limberg	2	
4	Marmon	Rouse	3	
51	Jackson	Cobe	No finish.	
Ten Miles Free-for-All				
2	Simplex	De Palma	1	10:43%
1	National	Limberg	2	
4	Marmon	Rouse	3	
13	Pullman	Burke	4	
23	Staver-Chicago	Du Closne	5	

### Quakers to See Speed Contests

PHILADELPHIA, July 24—Nine events are listed on the program for the fifth annual midsummer track meeting of the Quaker City Motor Club on the one-mile circular race course of the Philadelphia Driving Club at Point Breeze Saturday next, the entry blanks for which were issued this week. The series of races comprises four non-stock cars, divisions 2C, 3C, 4C and 5C, each 10 miles, for a money prize; one-mile exhibition for track record; class D, free-for-all, 5 miles, flying start, for the Remy Grand Brassard and Trophy; a 10-mile open handicap; match race between Burman and Knipper, and a 25-mile combination race.

The meet promises to be second only to the Fairmount Park road race in point of interest, for the country's speediest and most daring drivers will compete for the rich stakes which will be hung up.

### Picking Out Virginia Road

CULPEPER, VA., July 25—With the good wishes of Vice-President Sherman ringing in their ears three cars containing a number of good roads boosters left Washington yesterday en route to Richmond.

F. H. Elliott, secretary of the Touring Club of America, and Henry McNair, of the Blue Book, are in charge of the party, which consists of government and State road officials. The object of the trip is to pick out a good road south from Washington to Richmond over which a large number in Richmond in October will travel. That Virginia is alive to the good roads movement was manifested to the tourists in no uncertain manner. Enthusiastic greetings were extended them all along the line and the trip is bound to give the movement a big impetus.

Scenically Virginia is ideal, but its roads leave much to be desired. With a good system of roads it would prove a great touring ground. The present trip will do much to advance the cause. Vice-President Sherman gave the signal which started the tour and expressed his great interest in the work of the touring club.

## Amateurs Defeat Trade

In two-day reliability run of the Chicago Motor Club, the amateur team won the honors on the road and a new set of champions resulted from the field games that were enjoyed during the outing. The run was to St. Joe, Mich., and return, 222 miles. On the first day's run the amateur team drew only a single demerit, which was caused by a stalled motor.

CHICAGO, July 24—Undoubtedly the most enjoyable affair ever promoted by the Chicago Motor Club was the team reliability match between the amateur and trade members of the club, with which was combined a field day at the night stop, in which contestants had a chance to demonstrate their skill in athletics other than motoring. The team match took place Thursday and Friday of last week and resulted in a victory for the amateur team, which defeated its trade rival by a score of 221 to 287.868.

The match was to St. Joseph, Mich., and return, a distance of 105 miles going and 117 miles returning. The first day's trip was remarkable for the showing made by the amateurs, who only had one down—Charley Anderson, who killed his motor. On the other team, Charley Van Sicklen, William Roesch, W. D. Foreman and Harry Cooper were penalized for motor stops, Webb Jay found water in his gasoline, Tracy Holmes broke a crankshaft and burned out a bearing, while Harry Watts made a steering gear adjustment.

Coming home the second day more perfect scores were eliminated. On the amateur team Sinsabaugh had ignition trouble and never got away from St. Joe; N. H. Van Sicklen, Sr., was penalized when a chain jumped the sprocket, Claude Anderson was demerited heavily for work done, while Gaidzik and Laramie had motor stops. Charley Van Sicklen, of the trade team, changed a spark plug, Gregory had a motor stop, Watts did work and was arrested for scorching.

The trade team had sixteen drivers and the amateurs fourteen, therefore the dealers only were penalized 14-16 of a point instead of a full point. This drew the finish fine, because for a time it looked as if Claude Anderson would not finish. The rules penalized for work done and for being late at controls.

The field day sports were enjoyed by everyone. The baseball game was good, but the other events were more interesting. Swimming, golf, running, jumping, pool and bowling kept everyone interested and resulted in a new set of champions. The standing of the team match is found in the accompanying table:

		AMATEUR TEAM		
No.	Driver and car.	First day.	Second day.	Total.
1.	David Beecroft, Abbott-Detroit.....	0	0	0
3.	N. H. Van Sicklen, Sr., Apperson.....	0	1	1
5.	C. G. Sinsabaugh, Abbott-Detroit.....	0	150	150
7.	C. G. Heywood, Buick.....	0	0	0
9.	George Knab, Pierce-Arrow.....	0	0	0
11.	J. H. Smith, Halladay.....	0	0	0
13.	C. K. Anderson, Mitchell.....	1	0	1
15.	G. W. Gaidzik, Premier.....	0	1	1
17.	J. G. De Long, Halladay.....	0	0	0
19.	F. W. Jencks, Welch.....	0	0	1
21.	A. C. Berthold, Cadillac.....	0	0	1
25.	T. F. Laramie, National.....	0	1	1
27.	Claude Anderson, Empire.....	0	67	67
33.	J. C. Knisely, Marmon.....	0	0	0
Total .....		1	220	221
		TRADE TEAM		
2.	C. F. Van Sicklen, Ford.....	1	1	2
4.	C. E. Gregory, Chalmers.....	0	1	1
6.	Thomas J. Hay, Ford.....	0	0	0
8.	J. P. Frisby, Staver-Chicago.....	0	0	0
10.	Gaylord Warner, Thomas.....	0	0	0
12.	H. C. Watts, Alco.....	2	63	65
14.	Webb Jay, Rambler.....	105	0	105
16.	E. T. Wells, Imperial.....	0	0	0
18.	William Roesch, Pierce-Arrow.....	1	0	1
20.	W. E. Stalnaker, Premier.....	0	0	0
22.	W. D. Foreman, Oldsmobile.....	1	1	2
24.	H. W. Cooper, Chalmers.....	3	0	3
28.	Tracy Holmes, Corbin.....	150	Withdraw	150
30.	S. Breakstone, Special.....	0	0	0
34.	A. M. Robbins, Abbott-Detroit.....	0	0	0
36.	E. J. Malloy, Mora.....	0	0	0
Total .....		263	66	329
Fractional penalization, 287.868.				

## Awards in Prince Henry Tour

LONDON, July 24—The Prince Henry trophy, chief prize in the team match between the Royal Automobile Club of Great Britain and the Imperial Automobile Club of Germany, was won by the English team according to announcement made Thursday night. No scores were announced.

His Majesty the King's cup, a commemorative prize, went to the German club, while His Imperial Majesty the Emperor's cup was awarded to the Imperial club. Her Majesty the Queen's cup for the best appointed car on the German team was given to Landrat von Marx with an Opel, while the corresponding trophy given by the German Empress to the best appointed car on the English team was presented to N. C. Neill with a Rolls-Royce. Princess Henry of Prussia gave a cup for the next best appointed car on either team, which was awarded to F. C. Bowring, who drove a Daimler.

## Clean Scores in Cleveland Run

CLEVELAND, OHIO, July 24—The awards in the Cleveland News reliability run, made here Saturday morning, show that fourteen cars out of thirty-seven went through the test with perfect scores.

A small number of cars in the run came through without tire trouble of any sort. The large majority of the observers' cards, however, showed that the drivers in the run had tire delays.

The success of the run was in large measure due to the enthusiasm and earnestness of the officials. They were St. Claire Couzens, of the News, referee; Fred Caley, secretary of the Cleveland Automobile Club, checker; Peter Mayer, starter; E. E. Grimes, A. A. A. representative, and Harry Smith, chief observer.

## Fiat Wins French Grand Prix

PARIS, July 24.—Hemery in the Savannah Grand Prix Fiat was the only survivor in the French Grand Prix run over the Sarthe circuit, a distance of 402 miles, covering the distance in 7:06:30, an average of 56.54 miles per hour.



Some of the contestants in the Team Reliability Match between Trade and Amateur Members of the Chicago Motor Club

When the race was called off the little Bugatti 8-horsepower driven by Freiderich was in second place, having completed ten of the twelve circuits, or 334 miles, in 7:16:50. Gabriel in a Roland-Pilain did nine rounds in 8:04:38 and Leduc in a Cote, eight laps in 6:19:33.

Maurice Fournier and his mechanic were killed in the seventh round, caused by the front axle breaking and the car going into the ditch. Fourteen cars started.

### Eleven Entries for Glidden

So far eleven entries have been made for the tentative Glidden tour of 1911, leaving a minimum of nineteen more entries to be received prior to the time set for closing the lists on August 1.

Announcement has been made that unless at least thirty cars are entered there will be no tour this year. Strong hope is expressed that the list will fill satisfactorily and that the run from Washington to Ottawa, 1,089 miles, will be held some time in September. It is pointed out by those interested that a test of current or advance models in the fall must act as a live selling impulse to the trade, it being a notorious fact that Fall selling is about four times as difficult as Spring selling.

The list of entries so far is as follows:

- 1911 Cunningham model "H" (pacemaker).
- 1911 Oakland model "M."
- 1911 Ohio model "40."
- 1911 Abbott-Detroit model "B-11" (three cars).
- 1911 Washington model "D-40."
- 1911 McIntyre model "M-6."
- 1912 Maxwell (three cars).

### Buffalo Club Plans Big Run

BUFFALO, July 24.—The second annual reliability tour for the Laurens Enos and other trophies, to be held under the auspices of the Automobile Club of Buffalo, will be run September 6-9 over a course of 800 miles, thoroughly covering Western New York, from Lake Erie to Lake Ontario. Entries for the event close on August 15.

### Queen Cityans Will Climb

CINCINNATI, July 24.—The committee in charge of the Stanley Hill climb for Saturday, July 29, are assured of a successful event as to arrangements and entries.

Fully a dozen different makes of cars have already been entered. The contest is under the auspices of the Cincinnati Automobile Dealers' Association, and has sanction number 371 of the Contest Board.

Stanley Avenue hill is 2,340 feet in length. On one side of the course there is ample room for 20,000 spectators commanding an unobstructed view of the entire race. Both sides of the course will be protected from end to end with wire rope, in addition to which Chief Jackson has engaged to furnish 200 or more policemen to assure a clear course.

The program embraces eight events of which interest seems to center in Nos. six and eight, the former being for automobile club members only, and the latter a free-for-all.

### Premierites Nearing Pacific

RAWLINS, WYO., July 24.—The trans-continental tour of the Premier flotilla of ten cars is over two-thirds of the way across the country.

## War Automobiles Arrive

Six cars manned by cadets and equipped with balloon fighting guns and wireless reached New York Tuesday, after a tour from Chicago to Washington. Maneuvers were held near the National capital on a broad scale. Major Davidson of the regular army is in command.

SIX war automobiles manned by students of Northwestern Military Academy, Highland Park, Ill., and equipped with rapid fire guns capable of elevation to any angle for balloon destruction, arrived in New York Tuesday on their return trip from the field of special maneuvers at Washington.

Major Davidson of the army is in command of the party and under his direction the students have been making a special study of combatting balloons and other air craft in a military sense.

All the cars are fitted with guns capable of being handled by one man and two of them have complete wireless equipment as well as several balloon envelopes. The expedition will return to Highland Park by easy touring stages.

### Armleder Enters Automobile Field

CINCINNATI, July 24.—An event of considerable importance to Cincinnati and to the automobile interests is the entrance of The Otto Armleder Company to the ranks of manufacturers in the automobile industry. This decision is the result of about two years of exhaustive experiments, especially in the line of a delivery vehicle of capacity for about one thousand pounds to meet the demands of medium and light transportation such as laundries, dry goods, millinery, &c.

The vehicle will be called the "Armleder". J. Biederman, who has for many years been in the manufacturing plant of the Armleder Company, is the designer of the new machine.

### Havers Plant to Be Enlarged

PORT HURON, Mich., July 24.—It has been stated that orders for approximately 280 cars, or nearly \$500,000 of gross business, have been placed with the Havers Motor Car Company in the past few days and plans are now being formulated to immediately increase the capital of the company and the capacity of the plant. Several offers of large amounts of outside capital have been made, but have been rejected, as the present stockholders prefer to keep the enterprise a strictly Port Huron industry.

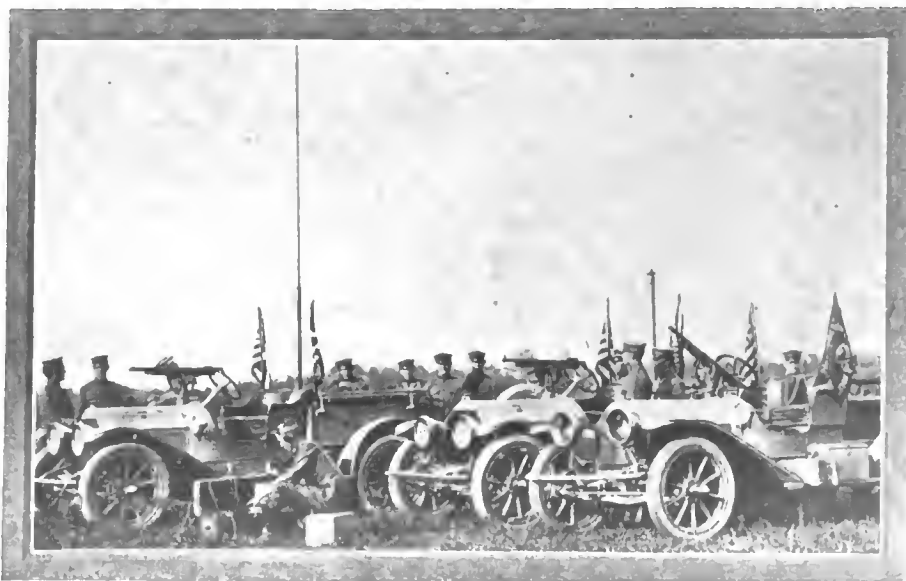

Businesslike balloon-fighting equipment of the students of the Northwestern Military Academy, Lake Forest, Ill.



# Minnesota-Helena Tour Now On

## Third Day Kills Many Perfect Scores

*With nineteen automobiles in the contesting column, the third annual reliability contest of the Minnesota State Automobile Association started from Minneapolis last week on its way to Helena, Mont. The tour is accompanied by a hotel train on the Great Northern Railroad which affords accommodations for the tourists en route.*

**M**INNEAPOLIS, July 19.—Under favorable auspices the Third Annual Reliability Run of the Minnesota State Automobile Association started from this city for Helena, Mont., this morning. There were nineteen contesting starters, but from this number must be deducted the Kisselkar pair, the Pierce-Arrow 7 and Packard 19 which will compete only in an unregistered or non-stock car class, owing to the fact that stock car certificates for them have not yet been issued.

The tour has been routed so that it parallels the Great Northern Railroad and a special hotel train accompanies the tourists. The train provides accommodations for 150 people and will stop at all the noon and night controls to serve meals and provide sleeping quarters.

The list of starters included the following:

Car No.	Make	Driver
1	Maxwell	O. W. Klose
2	Marmon	John Fawkes
3	Amplex	F. Kenneth Wiseman
4	Halladay	O. A. Palmund
5	Kisselkar	C. L. Bonwell
6	Kisselkar	Chris Rice
7	Pierce-Arrow	Julius Suckow
8	Hupmobile	E. B. Stimson
9	Abbott-Detroit	A. N. Smith
10	Stoddard-Dayton	J. H. Prior
11	Colby	M. G. Armstrong
12	Flanders	B. M. Scott
13	Flanders	F. A. Witte
14	Flanders	George Herron
15	Krit	J. E. Dougherty
16	Petrel	A. L. McNarlen
17	Cole	B. Terrell Hoyt
18	Cole	C. L. Rose
19	Packard	W. Stork

The referee is E. P. Dutton and pilot, C. S. Harrington, who laid out the route last spring following the line of march of the Lewis and Clark expedition. The pilot car is a Halladay, the pacemaker a Corbin, and the press car a Pierce-Arrow.

ALEXANDRIA, MINN., July 20.—At the end of the first day's run of the Twin City-Helena Reliability tour, all of the 19 cars entered as contestants checked in at the parking space here with perfect scores. While there were several cases of tire trouble none was serious and no trouble of any other description was encountered. To-day's run of 140 miles was over very good roads, but worse are to be encountered later, if the pathfinder is to be believed.

DEVIL'S LAKE, N. D., July 22—Penalties imposed on the contesting cars in the Twin City-Helena run for the first three days of the tour are as follows:

No.	Car.	Penalty.	Cause.
15	Krit	6	Replacement of broken steering arm.
16	Petrel	3	Taking on water.

With only two cars penalized during the first three days of the reliability run from the Twin Cities to Helena, Mont., all checked in here to-night on time. None of the contesting cars has had any accidents other than those for which penalties were imposed.

The roads from Fargo were excellent and the tourists ran ahead of schedule. Almost all the way was over smooth, hard

gumbo, which makes the finest kind of road when dry as it was this morning.

Soon after leaving Grand Forks it commenced to rain, which lasted all the afternoon, and the motorists were afforded a sample of wet gumbo. Tire chains became a necessity and even then the cars skidded badly at times.

The town of Devil's Lake was reached about seven in the evening. The tourists rest up here over Sunday and will check out for the next run of 167 miles to Berthold Monday morning.

BERTHOLD, N. D., July 24—Penalties for first four days of Twin City-Helena tour:

No. 15, Krit, second day, 12 points; third day, 38 points; total, 50 points.

No. 16, Petrel, third day, 3 points; fourth day, 12 points; total, 15 points.

No. 11, Colby, second day, 2 points.

No. 18, Cole, fourth day, 461 points.

No. 1, Maxwell, fourth day, 121 points.

No. 4, Halladay, fourth day, 36 points.

No. 3, Amplex, fourth day, 6 points.

The first car to suffer penalization was the Krit, which was assessed for the replacement of a steering arm. On the next day the replacement of two steering knuckles caused the assessment of the 38 points in addition. The 3 points against the Petrel were imposed for taking on water out of control, while the Colby was penalized for hooking up a loose wire on the accelerator.

To-day's run from Devil's Lake to the night control here is the hardest of the trip. In spite of this a schedule of 20 miles an hour was maintained and all but one of the contestants checked in before their time limit had expired.

The Stoddard-Dayton and the Cole 30 were the only cars to fall behind the schedule. A broken rear axle, sustained when the former made a wrong turn and the car ran into a coulee, laid it up for about two hours while repairs were being made by a neighboring blacksmith. None of the occupants was injured, but the driver and entrant, J. S. Prior, withdrew the entry from the run, intending to have repairs made and continue as a non-contestant. Upon his arrival at the night control with the car in running condition, Referee Dutton was petitioned by the other contestants in his class to allow Prior to continue as a contestant. The referee then permitted the car to check in as a contestant and assessed the penalties provided.

Many perfect scores were spoiled to-day by the rough roads. The motor on the Amplex, No. 3, stopped twice by the failure of the hand fuel pump to work. The Halladay, No. 4, sprung a leak in the gasoline tank and lost all its fuel, requiring two stops of 15 and 18 minutes respectively. The gas tank was removed and soldered. This car also lost a tire iron and the tail lamp.

Maxwell, No. 1, broke its fuel pipe after having been on the road only 20 minutes and was detained 12 minutes.

The Petrel added to its score by breaking both front springs. Temporary repairs were made by blocking them up with wood.

J. E. Dougherty, driver of the Cole, No. 18, distinguished himself to-day by making a novel repair of his gear-shifting mechanism in making a quick stop after taking the wrong road on the second day of the run. A lug on the gear shift arm was sheared off, preventing the use of any but high speed; after running a day and a half on the high, during which time it was necessary to both start and take all the hills on the high gear.

## Imperial Wins Trophy

An Imperial touring car penalized one point won the sweepstakes prize, the Milwaukee Sentinel Trophy in the Wisconsin State A. A. run last week. A Ford car was first in the roadster division while a Franklin took the honors in the privately owned division. Lewis Strang, racing driver, was killed by a caving bank during the tour.

MILWAUKEE, WIS., July 25—With but a single point charged against its record, a 1911 model 44 Imperial touring car, driven by Harry Bisbee, of Jackson, Mich., won the second annual reliability contest of the Wisconsin State Automobile Association, taking down the Milwaukee Sentinel sweepstakes trophy for a year and the Milwaukee Journal cup for touring cars, for permanent possession.

The Ford was close behind the Imperial and with its 2-point penalty won the Milwaukee Evening Wisconsin trophy for roadsters, to be held permanently.

The car was driven by William H. Diener, and entered by the Hickman, Lawson Diener Company, State agent.

The Emil Schandein trophy for one year's possession by the privately owned car making the best showing was awarded to J. D. Babcock, whose model "D" Franklin incurred a penalty of 17 points under the Grade 3 rules governing this division, and a 61-point penalty under the Grade 1 rules governing the trade classes, in which Mr. Babcock also entered and drove his car. The model R Reo, the only 1912 model in the tour, made an excellent showing, taking second place in the touring car class with only 6 points chalked up against it.

The Imperial's 1 point was incurred in the final technical examination, a bolt on the mudpan being found loose. It was at first thought that there was a radiator leak, but exhaustive tests showed this to be perfect. The car was gone over again, but no fault could be found and the final penalty was 1 point.

The model T Ford was a close contender with the Imperial for first honors. Diener incurred a penalty of 1 point for motor stop on the fifth day's run, and an additional point was imposed in the technical for a leaky water connection.

August A. Jones' No. 1 Cadillac, which made a beautiful run on the road and came through the brake clutch and motor tests clean, being touted as the winner, fell down on the final. Three points were imposed, 1 for a leaky connection and 2 for loose cap screws.

The winning Imperial's team mate, No. 7, stood fourth in the roadster division with 8 points. Herb Crampton lost 6 points in the brake test and 2 in the technical for loose bolts. The Warren Detroit made one of the best performances of any car and Rockstead was the only one to come through the final examination with a perfect score. However, he had been assessed 12 points for putting sand on a slipping clutch on the road and 2 points in the brake test.

The final result and penalizations, regardless of class or division, was as follows:

No.	Name of Car.	Driver.	Penalty.
8.	Imperial	Harry Bisbee	1
6.	Ford	W. H. Diener	2
1.	Cadillac	A. A. Jones-Fuhrmann	3
9.	Krit	W. G. Westwood	4
5.	Reo	A. J. March	6
7.	Imperial	Herb Crampton	8
15.	Warren-Detroit	R. D. Rockstead	14
12.	Overland	R. B. Bates-Heber	22
10.	Case	Will L. Jones	29
2.	Buick	Emil Hokanson	31
11.	National	Charles Merz	33
3.	Franklin	J. D. Babcock	61
3.	Buick	Geo. P. Hewitt	63
4.	Buick	Nicolanzo-Munson	162
14.	Regal	C. H. Delafield	259
16.	Petrel	Jesse J. Mack	1459

Lewis Strang, driver of the technical committee Case car, was killed Thursday near Richland Center. Strang had driven through a toll-gate and had stopped within 3 feet of an embankment waiting for a rig to pass. The bank gave way and precipitated the Case to the bottom. Strang was caught between the running board and ground and died almost instantly.

## Detroit News Notes

New automobile ordinance in Detroit has brought about a reign of terror among motorists. Welch-Detroit factory to move to Saginaw and car will in future be known as the Marquette. These plans also contemplate placing the Rainier car in the same category. Lozier will not race on dirt mile tracks. Other items from the manufacturing center.

DETROIT, July 24—Detroit motorists are just now undergoing a veritable reign of terror, due to the strict enforcement of the new traffic ordinance. The limitation of speed outside the mile circle to 15 miles an hour, the provision making it necessary to keep 6 feet or more from a standing street car and the prohibition against passing street cars to the left form the ground for most of the complaints, and the judges of the recorder's court have been assessing fines at a rate which surpasses anything in local history. Two sessions of the court resulted in the collection of more than \$2,000 in fines, while there are almost daily instances of heavy penalties.

The approach of the usual relaxation of activity is noted at the local factories. Aside from those already engaged in the production of the 1912 cars, the local factories are, generally speaking, engaged in clearing the decks for the change to new models and in the taking of inventory and the installation of new machinery. The rush of the busiest part of the season is now over and the period of transition finds but few of the plants running at top speed.

A feature of the retail trade this year has been the notable increase in the business done in used cars. One of the largest, best-located and most elaborately equipped of the new garages in the city—that of the Gillespie Automobile Company—is devoted entirely to the sale and repair of used cars. The showroom occupies one of the finest Woodward avenue corners.

An important announcement of the week comes from the General Motors Company headquarters and concerns the Welch-Detroit plant. This establishment has been ordered to prepare for a transfer to Saginaw, where the Marquette Motor Company's plant will be at last transformed into a real motor-car manufactory. The present name of the car will be abolished and the output of the plant will be known as "Marquettes." It is understood that the present Welch-Detroit plans will be carried out on a larger scale at Saginaw and combined with the plans of the Rainier, manufacture of which will also be under the new name.

The matter of racing on dirt tracks, both of mile and half-mile circumference, will be discussed here at the next meeting of the Manufacturers' Contest Association. There is a strong feeling among the manufacturers that such events are so unsafe as to court disaster, injuries to drivers and loss of life. It is not believed, either, that the cause of automobiling in general derives any benefit from such competition. Many of the manufacturers would be glad to sign an agreement not to race cars on such courses and to do all in their power to discourage their agents and owners of their cars from doing so.

## Large Garage Opened in New Jersey

Freehold, N. J., is now in possession of what is claimed to be one of the largest garages of the State. It forms part of the building of the Freehold Motor Co., agents for Maxwell and Columbia cars in that territory, who conduct the garage business in addition to a salesroom where accessories and tires are handled. The new building of the company is about 60 by 180 feet, the salesroom being 40 by 48 feet in area, and the garage having a capacity of more than 60 automobiles, 60 by 124 feet. In addition to this there is a machine and repair shop located in the rear of the building, equipped with the necessary tools and containing the air compressor and the power plant of the building. The building is constructed of hollow pile and concrete, thus being fireproof.

# New Things Among the Accessories

## Rust-Proof Demountable Rim

THE new rim illustrated herewith, and named after Detroit, where it is made, is distinguished by its locking feature which is seen in Fig. 1, showing a small portion of the rim. The lock L1 consists of a flat piece of metal with two segments cut out near its two ends for the ground joints J1 and J2 to fit in. In the center of the locking plate is punched a circular hole fitted around a strong metal ring which is securely fastened into the section of the rim S1, permitting the tire valve stem to come out through the ring. Turning the ring in a clockwise direction unlocks the plate from its relation to the ground joints and permits of lifting the section S1 from the rim without any effort; while, on the other hand, with the locking plate in position the section makes a waterproof fit against the rest of the rim. Furthermore, the lock is automatically held in place when on the wheel, because the construction of the lock assures a close all-around contact with the felloe band.

The second important characteristic is shown in Fig. 6, illustrating the special rust-breaking tool of the Detroit demountable rim. The necessity of a tool to avoid the formation of rust and to permit its eventual breaking off of the tire has long been recognized, and the makers of the Detroit rim claim to have solved this problem. The tool T1 consists of a bolt and two members, of which M1 is movable on the thread and rigidly connected to the shaft C1, while M2 is forged integral with a guiding ring G1 which permits the shaft to rotate in it. The use of the rust-breaking tool is as follows:

If rust formation between tire and rim is suspected or too close adherence between



Fig. 1—Showing the tire valve and demountable rim lock closed around it on the Detroit

them is to be avoided, the bolt is so turned by means of the handle that M1 is drawn toward M2, thereby contracting the rim, which diminishes its circumference while that of the tire remains unchanged. Consequently, the tire is broken loose from the rim, and for some time insured against rust formation. After the rim has been contracted, removing and replacing a tire is very easy.

In Fig. 6 are also seen the draw bolt B1 and wedge W1 which serve to fasten the rim to the wheel. The simple and substantial construction is clearly indicated by the

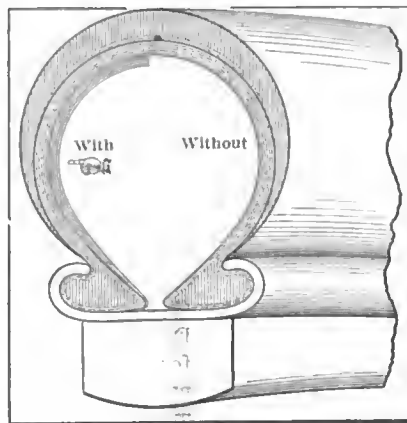

Fig. 2—The Tire Inner-Lining which prevents over heating of tire tubes, and minimizes blowouts

illustration, and mention is to be made of the fact that a draw flange is used back of the wedge without cutting or weakening in any way any part of the draw bolt, which is half an inch thick at its weakest point. The wider portion of the wedge opening permits the bolt to pass through it easily, and when placed in the wheel the bolt moves up automatically, making a unit with the wedge, which now has to come with the bolt if the latter is removed. Countersunk on the inside of the wheel hard brass nuts are provided to receive the bolt and hold it in place, and the use of brass prevents the formation of rust at this portion of the rim. There are six bolts used to hold the rim on to the wheel, and since the wedges cannot stick and rust in on the rim, the latter almost falls off on account of its weight when the bolts are loosened. Rusting of rim to felloe band is prevented by the special tool, and if they stick, expanding the ring will separate them.

With a set of five rims are furnished all the bolt wedges, felloe plates, end nuts, the rust-breaking tool and one wrench, by the Snyder & Harbridge Selling Company, 247 Jefferson avenue, Detroit.

## Tire Inner-Lining

BLOW-OUTS may happen while an automobile is running at normal speed, but in the majority of cases they occur when going at a high rate, comparatively, and their relation to the overheating of the tires is a well-established fact. Unfortunately, there is no way of keeping down the temperature of tires in a manner similar to the cooling of cylinders by water-jackets, but the problem of lengthening the life of tires under hard-working conditions resolves itself into an "insulation" being so introduced as to protect the tubes from the heat produced by the friction between tire and road. In the illustration (Fig. 2) is shown the asbestos leather inner lining, which consists of a double layer of asbestos with a stratum of hide interposed and which is placed inside the outer casing, thus shielding the inner tube from the heat. The makers, the Auto Tire Inner-Lining Company, of Cincinnati, Ohio, claim a very material increase of the life of tires where the lining is applied in the manner shown in the illustration.

## Hartford Safety Crank

STARTING CRANKS, unskillfully handled, are treacherous; they have caused numberless arms to be fractured, not a few skulls to be broken, equally numerous damage suits to have been brought to court and thousands of dollars to be expended in the abatement of what hitherto has been pretty generally considered a necessary evil. Probabilities are, indeed, that with spark and throttle properly adjusted, and a starting crank pulled up smartly, the operator will get away safely every time he performs this operation; but how many automobilists are there who always keep these simple points in mind? It is a peculiar property of the small objects distributed all over the world that they are extremely malicious.

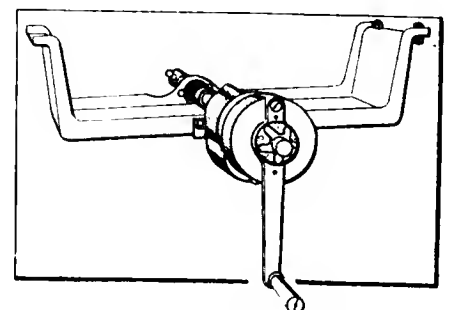

Fig. 3—The Hartford safety crank to overcome the deleterious effects of backfires

and just as pencils, matches, policemen and other desiderata are seldom to be found when needed, a starting crank seems to be awaiting an opportunity to break the arm of an unwary automobilist after having acquired his confidence by apparently tame and harmless behavior.

In such a live industry as that of manufacturing automobiles and their accessories there is no chance of a want being felt and not also being filled soon thereafter. Therefore, as the number of automobiles and with them the number of cranking accidents increased, makers of accessories and various constructors strove to devise some means of starting an engine without the operator being forced to encounter the dangers of the back-kick. Two schemes were adopted by the various makers—the self-starter, and the safety crank.

Describing one of the latest results of endeavor along this latter line, it will be of interest to note that the Hartford Safety Crank, which is made by the Hartford Suspension Company, of Jersey City, N. J., was evolved after three years' continual work. The problem was approached in a manner in which it had not been attacked before, the inventor utilizing the experience of the makers with Truffault-Hartford shock absorbers, in which a friction joint is used to take up a sudden shock caused by road inequalities. In fact, there is a miniature shock absorbing mechanism located between the crank and the gearing which transmits the cranking movement to the crankshaft of the engine.

The safety crank is illustrated in Fig. 3, indicating its strength and showing the nut used to adjust the pressure between the spring plunger pawl rigidly fastened to the crank and the stationary ratchet which is attached to a gear reduction box. If the crank is turned in the usual manner, it turns a friction disc mounted on a shaft which transmits the motion to the gear-wheel in the box where it is reduced to a low gear. The friction between the disc attached to the crank and the one mounted on the secondary shaft is sufficient to turn over the engine, but if back-firing should occur and the tendency to back-kick manifest itself a spring plunger mounted in the ratchet housing positively holds ratchet and pawl in contact, thus braking the torque exerted on the crank. The latter is thereby held in place, and owing to the minimum amount of friction between the discs, the secondary disc fails to turn the primary one—the one attached to the crank—around and slips without transmitting the work of the engine to the crank. In this manner back-kicks are avoided.

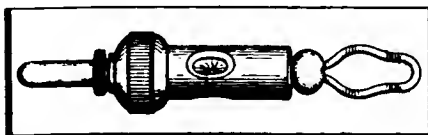

Fig. 4—Phelps spark plug attachment to detect the cylinders that miss fire.

The combination of the oilless friction discs and the low-gear transmission also results in easy cranking, avoiding all the dangers accompanying the lifting of a heavy weight, which may result in internal injuries even more serious than a broken arm.

### Spark Plug Trouble Finder

**M**ETHODS of locating a misfiring plug are numerous, and as a rule the most troublesome ways of doing this work are the least efficient. Automobilists who have gone through the embryonic stage of their career will appreciate a device that will help them to find out, in a short time, which of the four or six plugs refuses to work without getting their hands covered with dirt, soot and receiving an electric shock at times.

Among the several appliances now on the market for the purpose mentioned the Phelps trouble finder, shown in Fig. 4, is fastened to the terminal with the looped end, the other end being connected to the

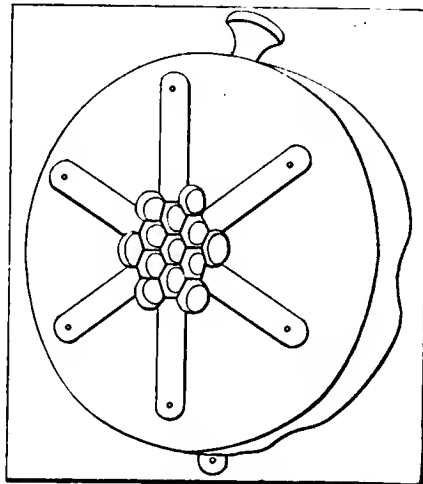

Fig. 5—Receiver on the Auristophone, saving the automobile passenger from excessive vocal strains

source of electricity, and when the plug works properly a spark will appear between the two points inside the trouble finder, while if the cause of misfire lies in the magneto or coil no spark will appear. This accessory is manufactured by the New England Equipment Company, Boston, Mass.

### Automobile Auristophone

The appliance so named and shown in Fig. 6 has been constructed with the object of increasing the comfort of the passengers, of a closed car, being either of the limousine, laudaulet or taxicab type. It is very unpleasant for a person riding in one of these comfortable machines to risk his safety whenever he wishes to give the chauffeur an order, but such a situation is hardly to be avoided if it is necessary for the passenger to put his head out of the window. Abstracting from the danger of such an undertaking, the point must be

borne in mind that the noise of the street makes it impossible for the driver to hear and understand "his master's voice" unless the latter shout in a manner which must necessarily hurt his own gentlemanly feelings.

Speaking tubes have been installed to improve the situation and a further step in the forward direction presents itself in the form of the auristophone, which consists of a reproducer to be attached to the outlet of the tubing and one or two receivers installed at the other end of the line. The receiver is shown in Fig. 5. A set of three cells delivering a current at 6 volts is the source of power which helps to intensify the sound waves entering the receiver in the interior. By pressing a button on the receiver the circuit is closed and the receiver put in action, taking up and intensifying the sound waves, and then transmitting them, as electrical oscillations, to the megaphone, the top of which carries the reproducer. The latter translates the electrical waves again into sound waves. The megaphone and reproducer are so placed that the intensified sound strikes the ear of the chauffeur directly, none of the sound being lost in the process, so that the orders of the passengers are clearly heard despite the noise of the street.

While the regular set sold by the manufacturers, the H. G. Pape Electric & Manufacturing Company, of Buffalo, N. Y., comprises one receiver and one reproducer, they also market a set permitting of the installation of another system in which two receivers are used and more sound waves are taken up and transmitted to the driver's ear.

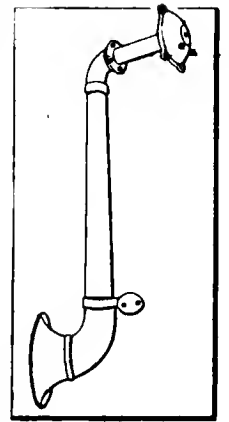

Fig. 6—The Auristophone, an electric sound transmitter

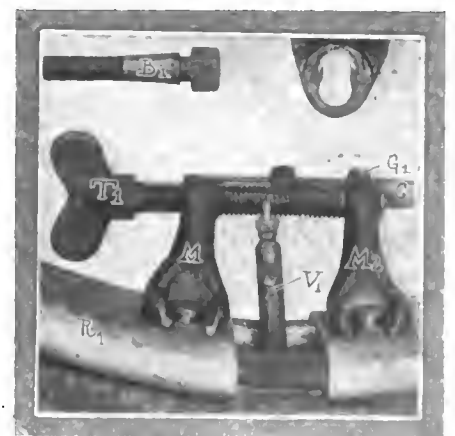
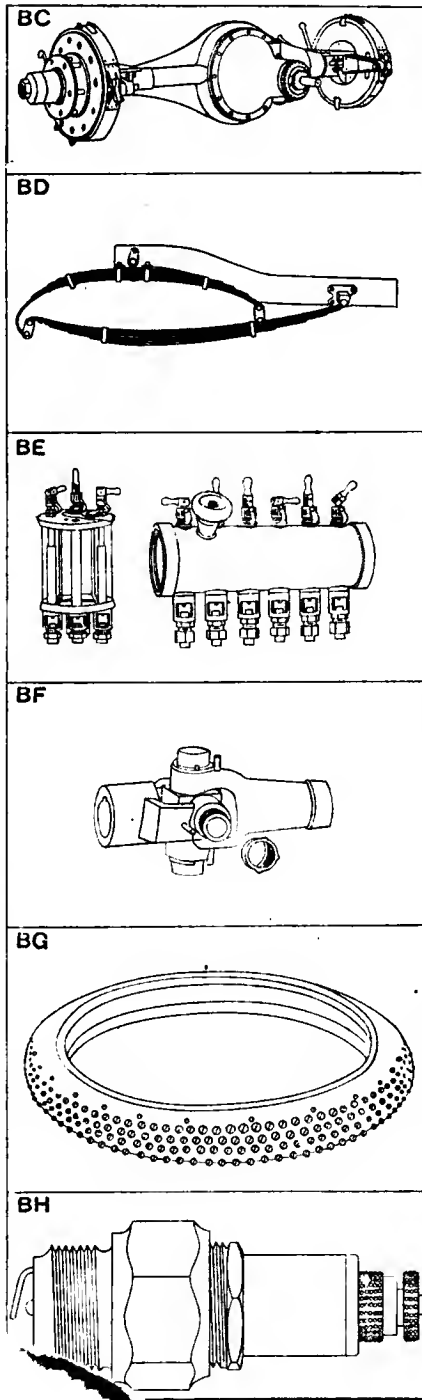

Fig. 7—The special rust-breaking tool, a feature of the Detroit demountable rim

# Seen in the Show Window

**M**ANUFACTURERS of assembled automobiles, if they feel determined to be successful in their business, turn their attention toward the quality of the material which is used in the makeup of the cars which their factories turn out. Unless such manufactories assemble high-class parts into a harmonious unit, all aiming at the target of success will remain futile, and time and money of the men directing the undertaking will be wasted. A good motor is the soul of the automobile, taking a good one for consideration, but to imprison it in a poorly made chassis, having low-grade axles and wheels means to throw pearls before the swine. The parts mentioned, to have inherent quality, must be the result of standardized methods of production and the use of up-to-date, reliable machine tools, and our illustration (BC) of the rear axle made by the American Ball Bearing Company, of Cleveland, Ohio, hints at strength and quality incorporated in the product by the manufacturing process.

**T**HERE is no way of avoiding depreciation in a machine, but the endeavor of the engineer is to concentrate it on as few parts thereof as possible, which in almost every case means a saving. While this process necessitates the use of high-grade material for the parts which thus take most of the strain, and this increases the first cost and maintenance of the part proper, the machine as a whole profits thereby and the owner saves in the long run. Automobiles, as they travel over common roads, would be bound to depreciate rapidly, were it not for the springs that are made to take by far most of the shocks and strains created by these conditions. At (BD) is shown the Radial Elliptic Spring, this being of the three-quarter elliptic type now generally used for rear suspension of an automobile. The City Spring Works, Twentieth and Santa Fe Railway, Chicago, are



there is a sight feed installed on the dash of his car. Two types of sight-feed lubricators are shown at (BE), both being made by the Lunkenheimer Company, of Cincinnati, Ohio. They are equipped with check balls and baffle caps, which insures proper working of the devices at all times, since because of the two features mentioned it is impossible for cylinder back-pressure to fill and stop up the sight feeds.

**A** CHAIN is no stronger than its weakest link, and considering the fact that an automobile driveshaft serves in a capacity somewhat similar to that of a driving chain, it stands to reason that the universal joint connecting this shaft with the rest of the transmission system must be very strong in order to withstand the strain put upon it by the hard work it has to do. A strong and simple form of universal joint is seen in the illustration (BF) and attention is called to the special type of grease cap, the thread of which has six turns and which is sure to stay in place and keep the part it covers well lubricated. This is the style A of universal joint made by Blood Brothers Machine Company, Kalamazoo, Mich.

**R**UBBER being an expensive material, numerous attempts are being made to replace it in tires, at least to some extent, and the use of a leather tread on a shoe built of Sea Island cotton layers frictioned with Para rubber is the practice of making automobile tires at the factory of the Racine Auto Tire Company, Racine, Wis. The tire is illustrated at (BG) and shows the anti-skid tread made of chrome-tanned leather, four strata of which are superimposed and united by three layers of pure up-river Para rubber. Rivets driven through the two top layers of the leather insure a non-skid effect, and from this peculiar construction has been derived the name Racine Horse-Shoe Tire.

**I**NSULATING materials used in spark plugs must have a high electrical resistance, and experimenting with several materials has led the makers of the Indian (BH) to the utilization of Indian pipestone specially treated by a chemical process. In addition to this feature, the plug is said to be damaged neither by excessive heat nor cold, nor will it retain soot, and the spark plug is guaranteed to last five years by the Templeton-Barrett Company, whose factory is at Marinette, Wis., while the Gotshall-Bailey Sales Company, of 1254 Michigan Avenue, Chicago, are sole distributors for this product.

BC—Rear axle made by the American Ball Bearing Co., Cleveland, O.  
 BD—Showing Garden City Works' radial elliptic spring of the three-quarter elliptic type  
 BE—Two types of Lunkenheimer sight-feed lubricators  
 BF—Illustrating a strong and simple form of universal joint  
 BG—Illustrating the Racine Leather-Tread Horse-Shoe Tire  
 BH—The Indian spark plug, made of Indian pipestone



# THE AUTOMOBILE

## What It Costs to Run a Truck Total Expense Based Upon Years of Service

*In this article, the fourth in the series showing the cost of operation and maintenance of automobile trucks, the total cost per wagon-mile is treated from the same broad viewpoint as in the previous articles. Both gasoline and electric wagons are considered and various types of each, representing hundreds of cars, followed through several years of actual service. The figures show that the average gasoline truck can carry freight at six cents per ton-mile and that a corresponding service can be performed by electric trucks at seven cents. Excessive speed is the worst element of waste of both varieties of cars.*

**C**OST of automobile truck operation and maintenance may be divided into four classes, excluding the wages of the crews from consideration. These classes are as follows: Supplies, including parts and everything that is required to keep trucks in commission; second—gasoline, current and oil; third—wages of garage employees or the costs of incidental and ordinary repairs and work in garages; fourth—tires.

In previous issues of *THE AUTOMOBILE*, each of the latter three items has been treated at considerable length and the matter of supplies has been gone into briefly in several connections with the main subject.

In the following article the total cost of operation of trucks without reference to wages of crews or the rental charges of garages will be treated from the same wide and liberal view-



FIG. 1.—PASSENGER AND FREIGHT MECHANICALLY PROPELLED VEHICLES LEAVING THE PENNSYLVANIA STATION

point as has been used in foregoing articles referred to above. Taking the wagon-mile as the unit for comparison and computation it has been found that it costs 1.772 cents to operate a truck one mile for tires. This figure is based upon the experience of 1,000 single solid tires in actual business service under varied and typical conditions and taking the tires from

a total of 2,348 cents for fuel and oil for each wagon-mile made by the gasoline cars under observation, the number of which was in excess of 300.

Considering the corresponding item with regard to electric trucks, the figures covering a period of four years show that battery and current costs and the expense for lubrication totaled 6.512 cents per wagon-mile. Roughly speaking this item may be divided into three heads as indicated. The approximate figures for each item are as follows: Battery, 3 cents per wagon-mile; current, 3 1-2 cents per wagon-mile, and oil, grease, etc., about 13-4 mills per wagon-mile.

In each case the average for garage work, wages of garage employees and ordinary maintenance and repair was a little over 3 cents per wagon-mile, the actual figure being 3.1 cents.

Battery costs follow the size of the truck very closely, but there appears to be a wide difference in the item of expense for current. For instance, the exhaustive tabulations show that the cost for current to run a two-ton electric truck is not much more than it is to operate a truck of half its size. Lubrication cost proportionately more for a big truck than it does for a small one.

The gasoline wagons of the same period used a certain amount of fuel which may be accurately gauged by the horsepower of the various cars involved. Thus the wagon-mile cost of gasoline cars, considering the three items, has been:



Fig. 2—Gasoline truck with four tons of merchandise

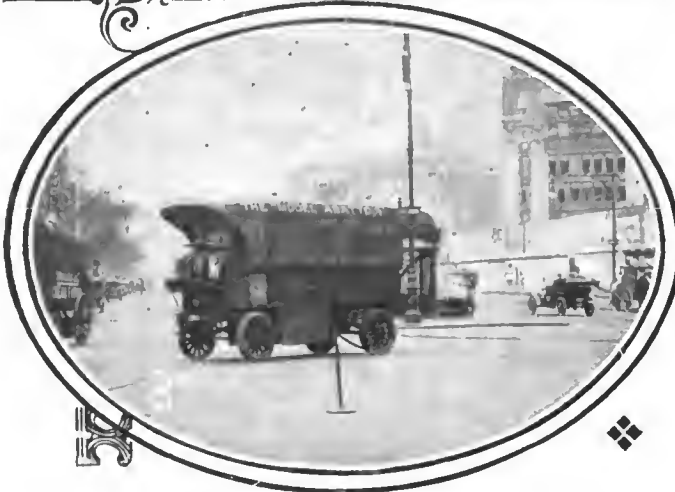

Fig. 3—The Model Abattoir uses electric trucks in its delivery service



Fig. 4—Small parcels being delivered by a Brush delivery wagon  
Fig. 5—Autocar express delivery wagon used for quick transportation of perishable goods



the moment they were first installed until their worn remnants were consigned to the scrap heap.

The automobiles upon which they were used are small trucks ranging in capacity from one ton to three tons in burden bearing ability and including both gasoline and electric vehicles of numerous standard makes. The range of tire costs was from something less than 1 cent per wagon-mile to slightly over 5 cents, with the average figure as stated above.

It was proven that excessive speed is by far the greatest element of loss in respect to tire costs and that the size of the truck has little to do with the wear and tear on tires as long as an economical rate of speed was pursued. The average tire mileage delivered was almost 12,000 and the original cost in the neighborhood of \$50.

The rate of speed ranged from about 10 miles an hour to more than twenty miles, with the average about 12.

There proved to be practically no difference in cost for tires used on both electric and gasoline cars, the extra weight of the electric being counterbalanced in tire wear by the more severe engine strains placed upon the tires by the gasoline cars.

As to fuel and oil for the gasoline cars, the experience with all the trucks of this type used in this illustration showed that the cost of gasoline was 1.74 cents per wagon-mile and that oil and grease made up another item of .608 cent, thus giving

Tires .....	.01772
Oil and gasoline .....	.02348
Garage work .....	.03100
Total .....	.07220

To this must be added the cost of supplies of every kind not

included among the above items, the parts that are used for replacements, and all material and merchandise as well as extraordinary repairs requiring unusual expense such as overhaul.

A broad experience of four years shows this item to be large and exceedingly important in figuring the total cost of truck operation; and in the cars used in this illustration it amounted to an average figure of 6.06 per wagon-mile. Thus the total cost of operation of gasoline trucks proved to be 13.28 cents per wagon-mile or a shade less than 6 cents per ton-mile.

It should be noted that the cost of operating gasoline trucks has been very materially reduced in recent years. A supplementary tabulation arranged from the data covering cars used prior to 1908 shows that operative costs were much higher before the gasoline truck reached its present stage.

Considering the electric trucks in the same way as the foregoing, the figures show the cost per wagon-mile as follows:

Tires .....	.01772
Battery .....	.02984
Current .....	.03356
Lubrication .....	.00172
Garage work .....	.03100
Supplies .....	.02366

Total ..... 13750

It will be noted that the item for supplies is vastly greater for

is about the same for both gasoline and electric trucks, with the balance favoring the gasoline cars. The difference is considerably greater to the advantage of the gasoline trucks when the computation is reduced to a basis of ton-miles. The tabulations show that the cost is about 7 cents per ton-mile by electric trucks and a trifle under 6 cents by gasoline wagons.



Fig. 8—Commer truck with chain cases handling pianos in New York  
Fig. 9—Electric wagons have a large field in the brewing business



Fig. 6—Large department stores employ a fleet of small wagons for express delivery

Fig. 7—Sampson truck with box type of closed body used for heavy work by paint manufacturers

the gasoline cars than it is for the electrics and this is explained by the fact that the cost of battery replacements and repairs are not included in that classification but are considered as a separate item.

In a comparative way it may be said that the cost of operation

On a basis of 10,000 miles a year, the actual cost of operating and maintaining a typical gasoline truck would be \$1,328, and for this price the truck would deliver 22,100 ton-miles of freight service. With the electrics delivering the same number of wagon miles per year the cost would be \$1,375, and the ton-mileage would approximate 19,650.

Thus the gasoline truck delivers the same number of wagon-miles as the electric truck for \$47 less a year, and, at the same time, on account of the larger size of the gasoline trucks used in this illustration, the ton-mileage is greater for that type of wagon by 2,450 ton-miles per year.

The best types of gasoline cars were operated at 12 cents per wagon-mile as a minimum yearly figure. These cars are modern trucks of three-ton capacity, and for a single year the ton-mileage figure has been as low as 4 cents. Other types of three-ton gasoline trucks have averaged 4 1-2 cents per ton-mile and those of smaller size run to larger figures in the ton-mile computation.

Referring to the experience with the earlier gasoline trucks, it may be said that the excessive operative costs were due solely to mechanical crudities which have been corrected in large measure in the wagons of current use. Some of these ran as high as 15 cents a ton-mile and delivered a comparatively small number of the revenue-producing units. This made a bad showing for gasoline-operated automobiles in comparison with the electrics and



Fig. 10—Couple-gear gasoline electric truck delivering ten tons of coal

for a time checked the extension of the lines of gasoline trucks.

The situation touching the electric truck operative costs is set forth in much detail in the data at hand. The best figures for one-ton trucks are about 8 cents, while the most economical of the two-ton types cost about 9 cents to operate and maintain. The two-ton electric truck stands out sharply as the more economical to operate on a ton-mile basis, as the total cost in this respect for the best types of electric trucks observed was 4 1-2 cents per ton-mile for year after year. They were no harder on tires, used very little more current and delivered twice the ton-mileage shown by the smaller vehicles.

As an illustration. On a basis of 9 cents, the cost of operating a two-ton electric truck for 10,000 miles in a year would be \$900, delivering 20,000 ton-miles without overloading the wagon. The best of the smaller trucks cost \$800 to deliver 10,000 ton-miles. Without regarding garage rentals and the wages of the crews and assuming that the gross revenue from this freighting would be 10 cents a ton-mile, the revenue from the larger truck would be \$2,000 gross or \$1,100 net in the course of a year. Of course the revenue from hauling is probably much more than 10 cents per ton-mile.

Turning back to the gasoline situation as above, the basis of computation of 10 cents per ton-mile would make the average revenue of the gasoline truck \$245 greater than that of the electric at a cost of \$47 less per year, thus indicating an economy in operation of the gasoline over the electric of \$292 a year.

However, these figures may be a trifle unjust to the electric because the cost figures of the ancient and expensive gasoline trucks were eliminated and all the data at hand were used with reference to the electrics.

Applying the pruning knife to some of the worst specimens of the electrics included in the data, it is found that the modern cost figures would probably be made more nearly approximate if a certain series of old one-ton trucks could be eliminated in the same way as the wasteful types of gasoline cars. For instance, a few years ago there were about 100 trucks of this kind in service, the data for which constitute a part of the material at

hand. These trucks cost 23 cents a ton-mile to operate for two years and by cutting them out of the calculations the result probably leaves the total figures very close to the actual present cost of truck operation. While the gasoline cars eliminated numbered only a few, practically all of which are now out of service, the electrics under the knife are still in service to a considerable extent. The elision leaves the wagon-mile cost of operation at 13 1-6 cents and makes the ton-mile cost under 7 cents.

If there is anything typical about the kinds of one-ton electric trucks that are included in the tabulations, it would appear that this size of wagon is not suited to competition with cars of double its size and being comparatively uneconomical in operation must give way to the larger cars.

But the most astonishing thing shown in the figures covering all the stages and phases of truck operation is the steady growth of economy in cost. While the price of freight automobiles remains substantially level and has done so for the whole period covered, the quality and mechanical excellence of the cars has increased. Dollar for dollar there is more value in the cars of the present than there was in the cars of the past, no matter what the price.

This increase in efficiency and economy may be shown briefly as follows:

In 1907 the gross cost per wagon-mile was 15.8 cents, based upon all the trucks used in this illustration. The gasoline trucks cost 24 cents per wagon-mile and the electrics 14.655 cents. The following year the wagon-mile cost was reduced to 15.09 cents, in 1909 to 14.17 cents and last year it came down to 13.56 cents.

This was accomplished in various ways, one of which was, of course, to eliminate the gasoline-eating and current-wasting machines and to substitute in their places cars typical of the state of the art. In order to show just what a potent cause in behalf of economy such practice proved to be, it is illuminating to know that the general proportion of cost was not disturbed by reason of the arbitrary culling out of the non-economical cars, resorted to in this article in an effort to approximate actual present costs.

With these eliminations the 1907 figures were 13.98 cents per





Fig. 11—Ice cream manufacturers are taking advantage of the new means of locomotion

wagon-mile; 1908, 13.89; 1909, 13.75, and 1910, 13.13. It is likely to be still further reduced in 1911 by reason of equalizing the efficiency of tires, so as to get uniform mileage out of complete sets, by enlarging the carrying capacity of electric trucks, by the substitution of small gasoline cars for the electrics of corresponding size and by a stern and rigid check on excessive speed. One of the striking things about the situation is the larger

mileage achieved by the automobile truck in 1910, compared with former years. In 1907 the general wagon-mileage was under 9,000, while in 1908 it was 500 miles greater. In 1909 the trucks made 10,300 miles and last year the figures were just short of 12,000 miles. Naturally these high figures are not general averages, but they do represent the performance of the best classes of trucks, some of them as much as four years old.

## Tour to Water Gap Is Delightful

### Fine Roads and Beautiful Scenery on Route

*Among the finest two-day runs afforded in the East is the tour from New York to Delaware Water Gap and return. This route carries the tourist through the hills of northeast Jersey and southeast New York, past Tuxedo and through the beautiful country lying to the west. The way reaches Port Jervis and enters the picturesque country near the Gap over smooth, well-kept roads, bringing up at the chasm in the hills through which the Delaware River flows down to the sea. The return trip takes the party down stream, crossing into Jersey and mounting the Schooleys on the way to Morristown.*

ONE of the puzzling questions that constantly confront the car owner is: Where shall we tour? and it is answered in so many ways and so differently that the owner is often more confused by the advice he receives than helped by the suggestions offered. If he has tried the New

England hills and the Connecticut, Long Island or Jersey shores, or even if he has not, he might try a run to Delaware Water Gap some Saturday and return through Jersey the next day.

He will not be disappointed in the roads, for they are among the best on this side of the world. There will be no hardships from one end of the trip to the other and the scenic beauties compare favorably with anything to be seen in this part of the country. In fact, there are spots along the way that rival in grace and beauty any in the world. There will not be a monotonous moment during the trip if diversity of scene and calm enjoyment of nature's smile have the power to charm.

The trip is not arduous in any way, the roads being well-nigh perfect and the mileage moderate.

Starting from New York City in the mid-forenoon the tourists proceed to the Fort Lee Ferry across the Hudson at One Hundred and Thirtieth street. By following Route 18 of Volume 3 of the Blue Book the landing is made on the Jersey shore at Edgewater which lies at the foot of the Palisades. There is a long, stiff climb to the summit, but the hill is not so steep as



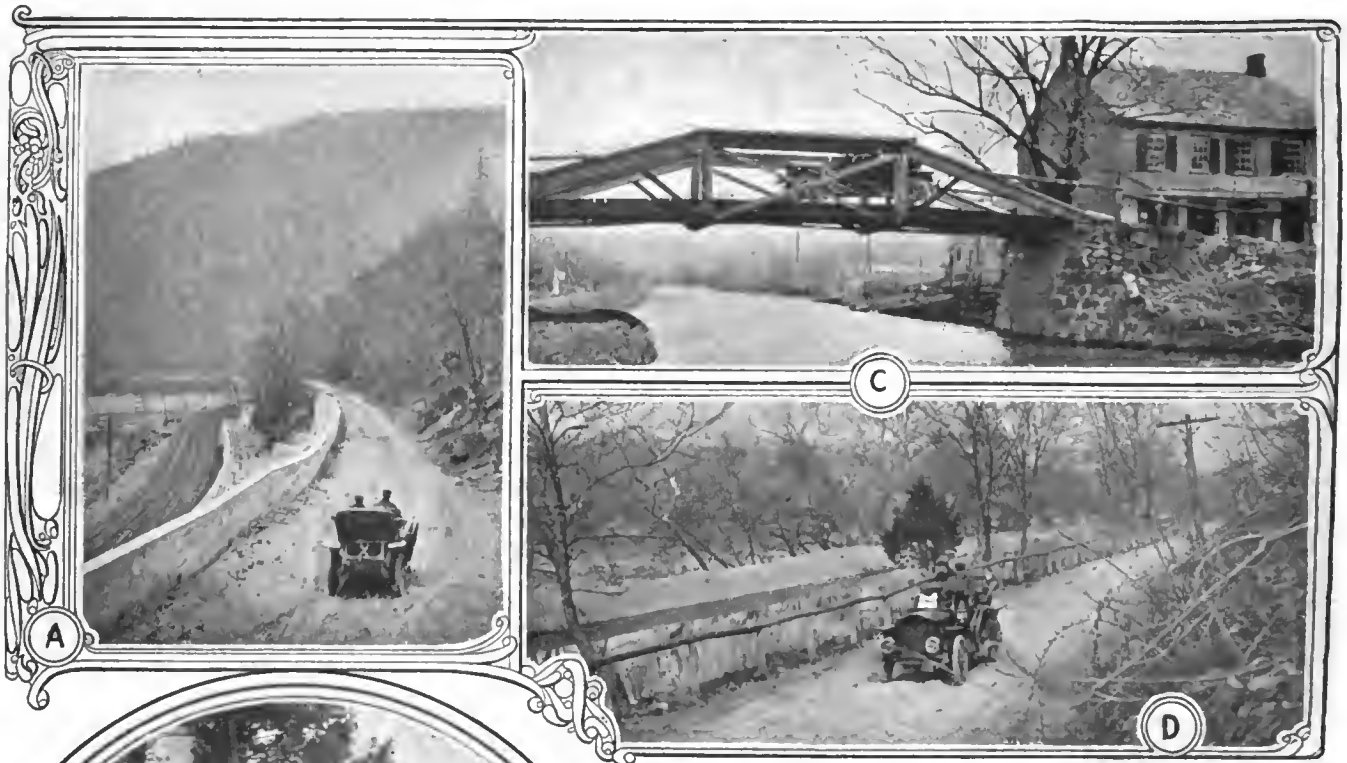

A—Where the Delaware breaks through the granite hills  
 B—On the road to Milford town through the woods  
 C—One of the many bridges that span the canal paralleling the Delaware  
 D—Leaving Port Jervis on typical road of the section



to cause trouble if a little care is devoted to shifting gears. Fort Lee village lies on top of the hill, from which on a clear day a view of Washington Heights and the full sweep of the North River waterfront of the metropolis may be had. This view will give a better idea of the immensity of New York City than the most perfervid descriptive pamphlet, no matter how voluminous.

After crossing the backbone of the ridge the way descends to Overpeck Creek, and then crossing the Hackensack River just before reaching Hackensack, the party passes through that village on the way to Arcola. The old mill that has done service for generations is one of the interesting sights to be seen here.

The road, splendid macadam, continues through Hohokus to Suffern, which is just across the New York State line. Here the road divides, one branch following up to the Hudson River at West Point and the other bearing straight ahead to the crossing of the Ramapo River, thence to Ramapo and Sloatsburg, reaching Tuxedo about two hours from the start. Tuxedo is a resort for New York millionaires and is considered to be one of the most magnificently improved suburbs in the world.

From Tuxedo the way is through Southfield, Monroe, Chester and Goshen. From Goshen to Port Jervis the road is through one of the richest agricultural sections of New York. The country is varied in aspect, rich and rolling and with enough timber to afford a wealth of color and shadow to the landscape.

This road passes through Denton and Statehill station over Shawangunk mountain, descending a long grade with several interesting turns and sharp curves. A short distance farther the road winds through the village of Tri-States and reaches Port Jervis at Front and Pike streets.

The run so far has been 76.4 miles, a nice easy jaunt of four hours. There are a number of excellent places at Port Jervis where the party may have luncheon, after which the rest of the run to Delaware Water Gap may be finished with ease through the most picturesque section of the hill country.

Route 341 of the Blue Book is the favorite way to pursue from Port Jervis to the Gap and passes over fine roads, the base of which is shale. The road follows down the Delaware River Valley and is noted as being one of the favorite runs for automobilists. It is supremely picturesque and must be seen to be appreciated.

Crossing the Delaware into Pennsylvania the way leads to Milford through a scene of natural beauty that would be hard to equal on a Summer day, and following west and south it crosses Sawkill Creek. The woods are a magnificent feature of this stage of the journey, although every turn of the road develops some new natural beauties. At Dingman's Ferry and along the way leading to it there are some delightful waterfalls to center attention. The creek is crossed by a modern iron bridge, but the ruins of the old bridge and ferry form an interesting point.

Egypt Hills, Bushkill station, Shoonmaker, Echo Lake are passed in order and the party reaches Shawnee-on-Delaware in about two hours' leisurely run from Port Jervis, the mileage being 36.3.

The rest of the way is largely up grade to the North Water Gap postoffice, where the hill road crossing Cherry Creek brings the tourists to the end of their journey.

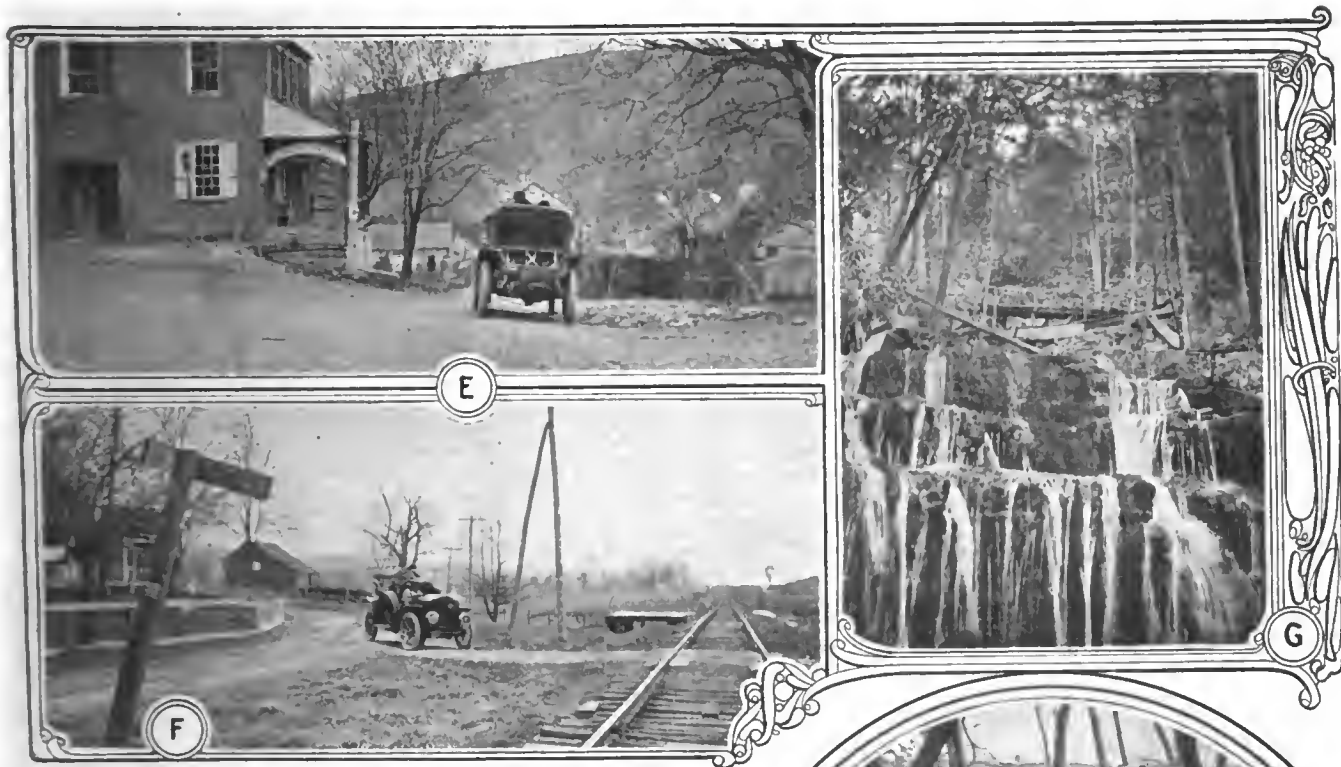

E—Stopping at a wayside inn high in the hills  
 F—After leaving Shawnee in the final run of the first day  
 G—Typical scene in the mountains west of Port Jervis  
 H—In the heart of the Delaware Water Gap



There are numerous hotels at Delaware Water Gap, several of which are said to be of first-rate class.

The return trip through New Jersey is delightful and interesting but entirely different from the outward-bound journey. Following Route 332 out of Delaware Water Gap the run to Morristown, N. J., is only 50.7 miles. Leaving the Gap the party trends southward along the Delaware River to the old-fashioned cable ferry, where the automobile is embarked upon a flat boat and pulled across the stream to Myers Ferry, N. J. From the landing the way rises gradually and then sharply, passing Hackettstown. The towns along the way south of the Gap are: Portland, the Ferry, Delaware, Bridgeville, Butzville, Townsbury, Danville and Meadow Station.

Continuing nearly straight ahead into Main street, Hackettstown, the party passes the Soldiers' Monument and crosses the Musconetcong, where the ascent of Schooley's Mountain commences. At the crest of this beautiful hill is a wonderful view of the Musconetcong and German valleys. This section used to be one of the leading resort districts of New Jersey, and the reason for its not maintaining that rank is difficult to understand. The descent is also sharp and complicated with a dangerous horseshoe curve. The grade is about a mile and a half in length and the roads on both sides of the mountain have been finely improved, which adds materially to the pleasure of the trip and makes for safety of the tourists. Reaching German Valley station the road turns left after crossing the stone bridge and proceeds to Chester, Mendham and into Morristown. If a late start was made from Delaware Water Gap, it may be well to have luncheon at Morristown, where there are a number of creditable hotels. This little city has an immortal place in history as the headquarters of Washington in one of his Jersey campaigns.

From Morristown to New York there are several fine routes, but the choice will probably fall upon Route 126 on account of the two fine, easy climbs over the Watchung Mountains over splendidly improved roads. This route is via Florham Park and Newark and is 31.1 miles in length, entering the metropolis by the Weehawken Ferry at Forty-second street. The route takes

the party through Madison, Florham Park, mounting a small hill and passing across the Passaic. Then comes the climb over the Watchungs, beginning with a long, steep grade across the first range and then, after a dip, commencing the climb over the second barrier, which is accomplished by a gentle and smooth ascent.

From there into South Orange the road sinks away smoothly into the plain and reaches Newark via Central avenue and Washington street. The way to New York through the New Jersey metropolis follows Bridge street, crossing the Passaic to the new tarred macadam road connecting with Hudson Boulevard, Morgan street, Bull's Ferry road, Third street, to the Weehawken Ferry.

The entire distance of the return trip is 81.8 miles, and for the whole journey out and back 197.9 miles. There is scarcely a mile of the way that is not well improved and well maintained, and the whole trip ought not to cause a moment's uneasiness to the automobilist. Garages and tire stations are frequent throughout the route, but with the fine roads there is little reason to anticipate needing them.

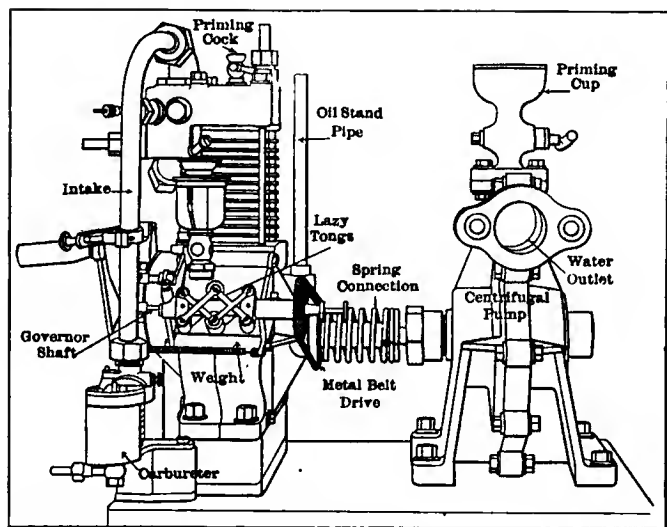

Illustrating one-horsepower air-cooled gasoline motor driving a direct-connected centrifugal pump

## Direct - Connected Motor and Pump

*The greatest efficiency possible is always secured by means of direct drive between the power plant and the driven piece of machinery. Where direct connection is possible the wear and tear of bearings and gearing is done away with, thus reducing the cost of up-keep.*

THE accompanying illustration will give an example of how a pump may be connected directly to a gasoline motor. Of course where a reciprocating pump is used the only way possible to secure a direct drive is by having an engine with

an opposed water cylinder. The centrifugal pump, as shown in the cut, can be connected directly to the extended crankshaft of the motor, and is driven at the same number of revolutions per minute as the gasoline motor.

The noticeable features in this plant are the spring connection between the motor and the pump and the governor on the motor. The spring connection is a safety device. In case the pump should, for any reason, become clogged so that it is jammed, the spring joint will be broken instead of the shaft. The spring can be easily relaxed, while to replace the shaft would be a very costly proceeding, not to mention the fact that many other parts may be broken.

The governor is of the centrifugal type. It is driven by a wire belt off the crankshaft. As the speed of the motor rises above normal, the weights on the joints of the lazy tongs are thrown out by centrifugal force, thus contracting the lazy tongs and moving the governor shaft which throttles the motor and cuts down the speed. As the speed is reduced the weights will fall back nearer to the axis and the throttle rod be pushed forward so that the throttle will be again opened and will remain so until the motor rises above normal speed.

The motor shown in the cut is a small one of one horsepower lubricated by gravity and splash and cooled by air. The pump and motor are assembled on the same base, which is so constructed as to bring the engine and pump shafts on the same level with each other. This gives a very light and compact little plant and one which may be used in a great variety of ways.

A pump of the centrifugal type is of great use in pumping water against a small head. When the back pressure runs up high there is a large percentage of the total efficiency lost in slip. This is true, of course, of the reciprocating pump as well, but not so much as in the case of the centrifugal type. This combination would be an ideal one if used for pumping the circulating water through a condenser in a steam yacht.

## Concerning the American "30"

### Latest Effort from the Plant at Indianapolis

*It is worthy of note that the underslung idea is being continued by the maker of this car, and the idea here is to present a strictly mechanical version of the ramifications of the new product, showing the relations of components in the makeup of the car.*

REFERENCE may be had to Fig. 1 for the general appearance of the new "30" model showing an underslung spring suspension and an enclosed type of body, with admittance to the tonneau on both sides, but the right side of the fore part of the body is blind, leaving room for the side

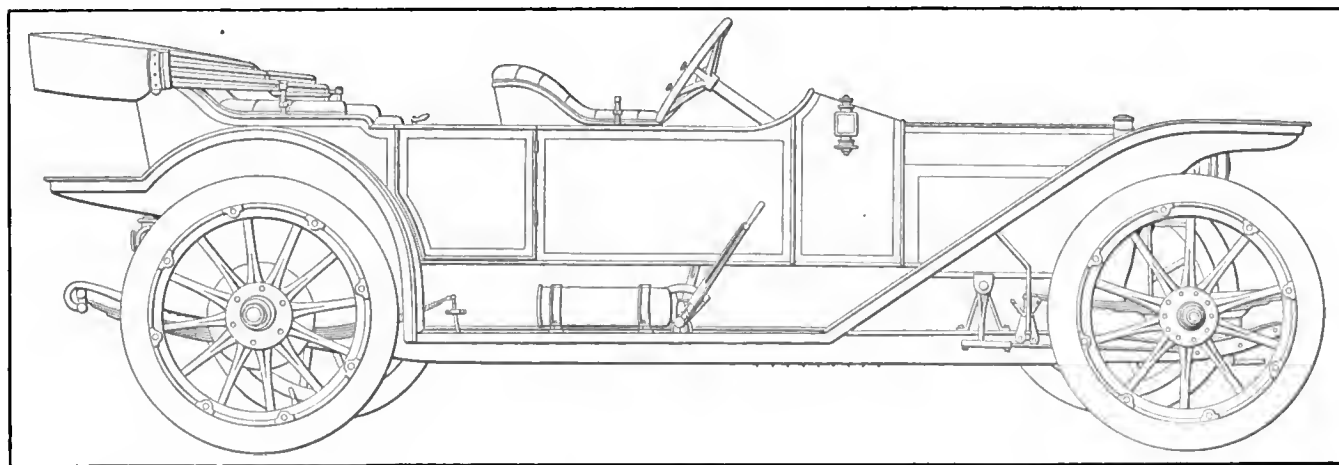

Fig. 1—General appearance of the new "30" American with flush-sided body, the front compartment being fitted with only one door

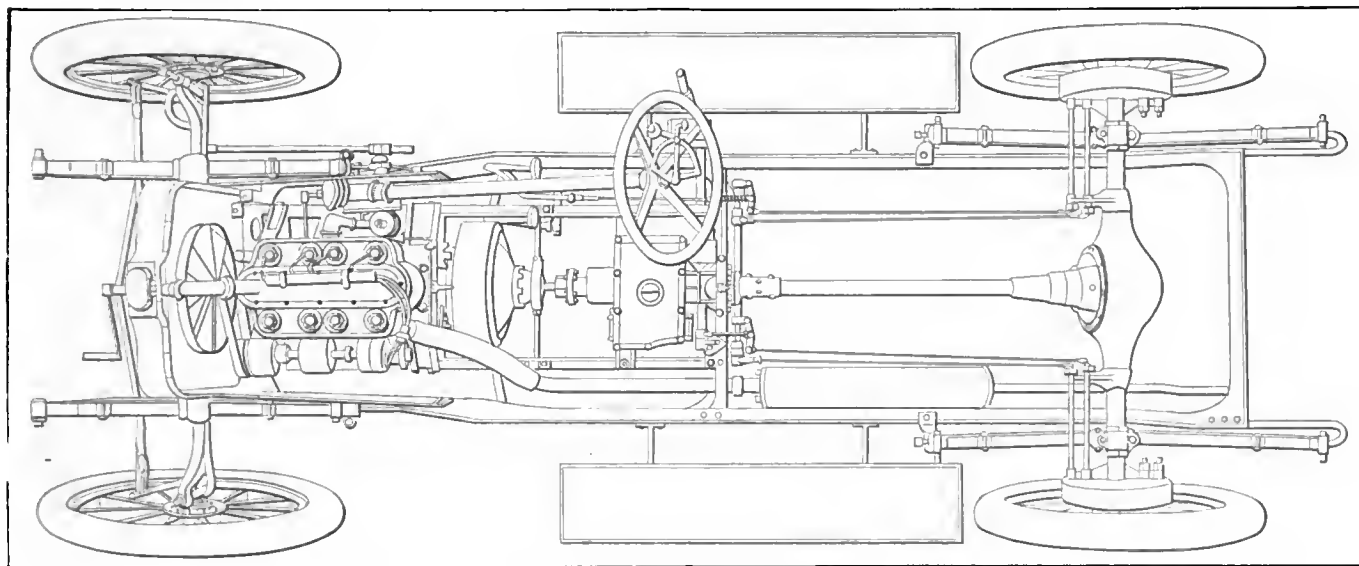

Fig. 2—Plan view of the "30" American chassis, showing the relation of the different parts

levers in the manner as shown, admittance being to the front seats by a fore-door on the left-hand side of the car. The general appearance of this model conforms to the broad idea of the American Motors Company, of Indianapolis, Ind., remembering, however, that a year's practice has brought about its refinements, leaving a certain indefinable something about the car as here shown that is not to be described in terms that fit the mechanical treatment of the car.

The plan of the chassis is shown in Fig. 2 with the radiator at the front of the motor placed far enough back on the side bars to clear the axle. The motor, including the transmission, is mounted on a sub-frame, making a substantial platform for the power plant, terminating in a crossbar back of the transmission gear, where a universal joint is placed at the extremity of the torsion tube, the latter enclosing the propellershaft so that the power of the motor is transmitted therefrom through the clutch housed in the flywheel, thence to the three-speed selective-transmission gear and to the propellershaft through the universal joint, thus delivering the power at the point of contact of the rear road wheels through the live rear axle. The scheme involved in the chassis construction for the purpose of taking advantage of the underslung plan of suspension is shown in Fig. 3.

### How the Block Type of Four-Cylinder Motor Is Made

The four-cylinder block type motor is rated at thirty horsepower when the speed is 1,000 revolutions per minute. It is of the four-cycle type, water-cooled with four vertical cylinders, with a bore of 4 3/8 inches, and a stroke of 5 inches. The right-hand side of the motor is shown in Fig. 4 with the carbureter C<sub>1</sub> in the mid-position, and the intake manifold leading up therefrom to a flanged orifice in the cylinder heads in the manner as shown. The motor is suspended by integral arms B and B<sub>1</sub> reaching to the sub-frame, and the starting crank has its support S<sub>1</sub> integral with the crankcase, although in the assembling of the chassis a crossbar at the front carries an out-board bearing lending stability to the starting crank support.

A cover C shown on this side of the motor, enclosing the valve mechanism, and the water manifold W is faced off and bolted to a finished face on the top of the block casting, which seems to be one of the most recent and approved ideas in water connection work. The bottom of the crankcase, which composes an oil reservoir, is provided with draincocks D and D<sub>1</sub>. Referring to Fig. 5 of the right-hand side of the motor the magneto M of the Bosch dual type is mounted on a ledge, taking its drive through a shaft terminating in a gear which meshes

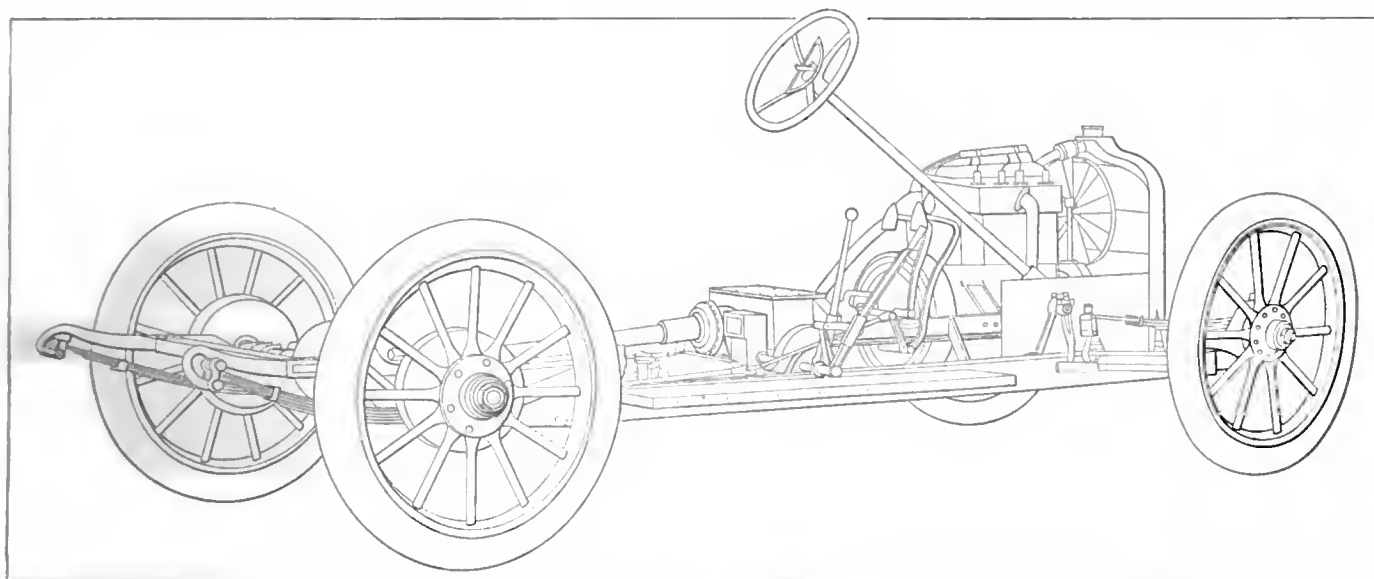

Fig. 3—Three-quarter view of the American chassis, showing the underslung feature, the method of suspension and the sub-frame, carrying the motor and transmission

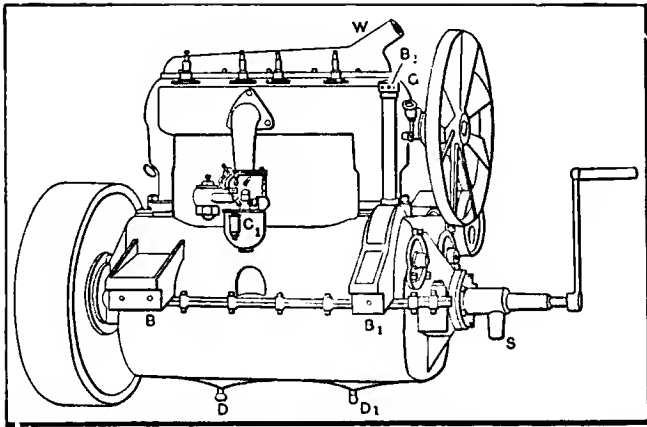

Fig. 4—Right-hand view of the motor, showing the short carbureter intake manifold and enclosed valves

in the half-time train, and the shaft is extended on through the water pump P furnishing power thereto and thence to the front of the motor with a pulley secured thereon, accommodating the belt B that drives the fan F1 as it is located between the radiator and the motor. Remembering that the motor is of the T-type with inlet and exhaust valves on opposite sides, it will be seen that a cover C is placed over the valve mechanisms on this side of the motor.

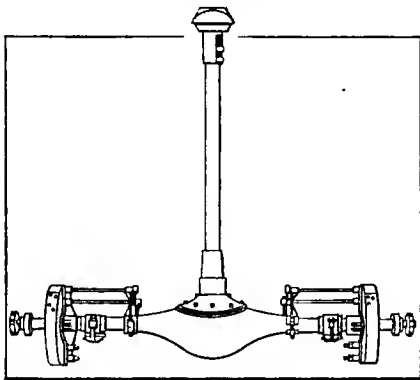

Fig. 6.—General appearance of the rear axle, showing the propeller tube casing with ball socket end

The exhaust manifold is cast integral with the cylinders and is therefore watercooled, terminating in the extension M1, which is bolted to the rear end of the cylinders and suitably connected to the exhaust pipe. The general appearance of the motor is very clean and some idea of the accessibility,

can be obtained from Fig. 3. The pistons and cylinders are ground and the former are fitted with four piston rings each. The timing gears are cut spiral with the object of eliminating any noise in this part of the mechanism. A system of splash oiling has been adopted, the various levels being maintained by means of internal webs. The bearings are large in diameter and are die-cast and scraped to fit.

The clutch is of the inverted cone type, the male member

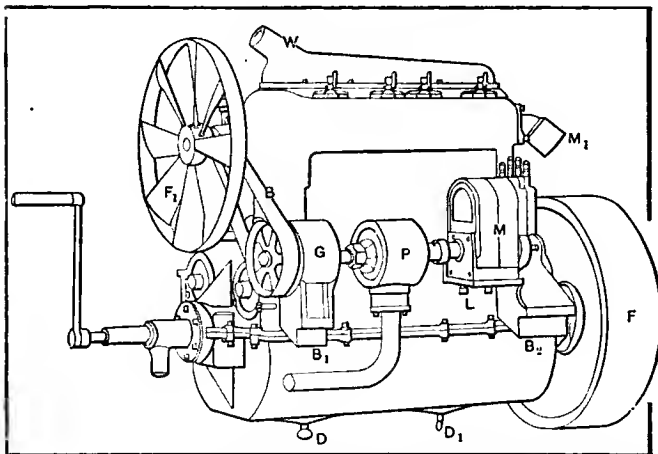

Fig. 5—Left-hand view of the motor, showing the arrangement of the magneto, pump and fan drive, together with the integral cast exhaust manifold

being faced with a suitable material to take the drive; spring plungers are placed under the surface to permit of easy engagement and in a measure eliminate the shocks of starting. In order to make the operation of the clutch as light as possible the pedal arms have been designed with sufficient reduction to eliminate the fatigue in traffic driving. Between the clutch and the transmission is placed a universal joint to compensate for any bending action of the chassis, caused by inequalities of the road.

The transmission is located amidships and is easy of access by removing the floor boards under the driver's feet. The casing is of cast aluminum and is shown in Fig. 11. It will be noticed that the gear-shifting mechanism is entirely encased, thereby insuring efficient lubrication. The forward end of the housing is extended to accommodate annular ball bearings on which the shafts are carried. Three forward speeds and reverse are provided, and a gear-shifting lever is equipped with a ball handle so as to give the driver a good purchase. The gear wheels are made of special steel, heat-treated and tempered, and the same applies to the primary and secondary shafts. The direct drive is obtained on third speed. At the rear of the transmission is located the housing providing for a ball end thrust for the front end of the tubing which encloses the propeller shaft.

As will be seen by referring to Fig. 3, the front and rear ends of the springs are shackled, thereby eliminating the drive from the springs. The rear axle, shown in Fig. 6, is of the full-floating type, the tubular extension of the housing being fitted with ball bearings upon which the wheels are mounted.

The housing is a pressed-steel forging, the front end being provided with a cover which receives the rear end of the propeller shaft casing. The jackshafts fit into the differential at one end, and the external ends are provided with dogs which drive the wheels through suitable slots cut in the hub.

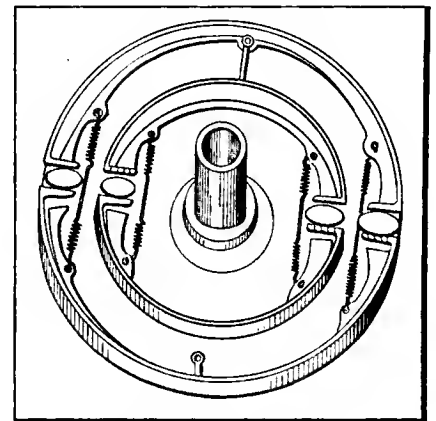

Fig. 7—View of the rear brake mechanism with the wheels removed

The differential assembly will be seen in Fig. 8. The crown wheel is attached to the exterior of the casing by means of bolts, and the casing is fitted at its two extremities with ball bearings which rest inside the axle casing. The brake drums which are attached to the rear wheels have two facings of different diameters to accommodate the two sets of brake-shoes shown in Fig. 7, both being of the internal expansion type.

Following along the lines of previous American practice, the wheels are of larger diameter, fitted with Q. D. demountable rims and 36 by 4-inch tires. The wheels are of the artillery type made of second-growth hickory with ten spokes front and twelve spokes rear.

The front axle shown in Fig. 9, is an I-section drop forging, with the cross-tie rod placed in front. The axle has a clearance off the ground of 10 3-4 inches, and is the lowest point of the car. The steering knuckles are fitted with roller bearings on which the front wheels run, and are attached to the main body of the axle by means of case-hardened and ground pivot pins; they are fitted with grease cups to insure proper lubrication.

Both front and rear springs are of the semi-elliptic type, the method of suspension being shown in Fig. 3. The steering is of the irreversible worm-and-gear type, and is attached to the chassis frame by means of two feet, the drop arm which is



fitted with a ball socket being placed exterior of the hood. The control levers are placed in the center of the steering wheel, which is 18 inches in diameter, and operate the control rods through two sets of bevel gearing which can be seen in Fig. 10.

The wheelbase is 118 inches, and the general equipment of the car includes top with dust cover and side curtains, five lamps, Prest-O-Lite tank and quick-demountable rims.

In addition to the "30" model, the 50-horsepower model will be continued in its present form with the exception of a few modifications, but in order to accommodate a six-passenger touring body a 140-inch wheelbase chassis may be had at the option of the purchaser.

It is proposed, in the near future, to place on the market still another model with practically the same features as mark the one herein described—for instance, the underslung frame—and the size of the motor will be 3 3/8 inches bore by 4 1/2 inches stroke.

With the coming demand for some provision of furnishing electric light for the lamps, the motor of the 30-horsepower model has been arranged for the installation of an electric-lighting outfit, the drive being taken from the pumpshaft by means of a belt. Considerable additions have been made recently to the size of the factory and it is the expectation of those connected with it to materially increase the output for the coming season, which will be largely due to the addition of the

30- and 20-horsepower models to the line.

The price of the new "30" model is fixed at \$2,250 with the style of body work as shown in Fig. 1, together with a complete equipment as above described. The bodies are made of sheet steel on a seasoned ash framework, and owing to the underslung chassis the passengers are brought lower than in the ordinary type, thereby causing the center of gravity to be considerably

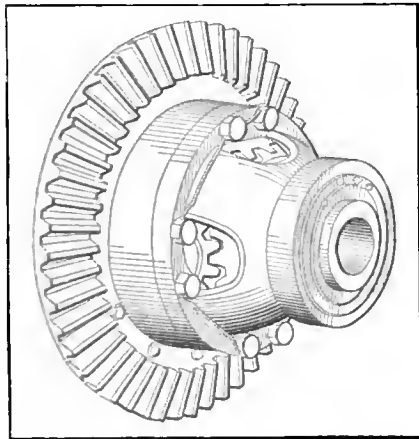

Fig. 8—Differential unit, showing how the crown wheel and ball-bearings are mounted on the cage

lowered. The advantage claimed for this in conjunction with the large wheels is that the turning-over effect is thereby decreased.

### It Stands to Reason—

- THAT an automobile that gives off a variety of odors is afflicted with a similar variety of disorders of its internal organs. It needs a stomachic.
- THAT a chauffeur whose breath attars the air with alcohol fumes needs a permanent substitute.
- THAT an indolent person is lacking in understanding—not liking work, he carelessly smears the body of his car with sticky matter which he has to clean off.
- THAT a tyro in the automobile art should not be assigned the task of adjusting a carbureter.
- THAT misery is the concomitant of undue haste in the selection of an automobile.
- THAT the well-behaved motor of good antecedents usually shows its class by the quiet and business-like way it goes about its duties.
- THAT the recurrent squeak that troubles the soul of the automobilist is doubtless the querulous plaint of some bearing that is athirst for lubricant.

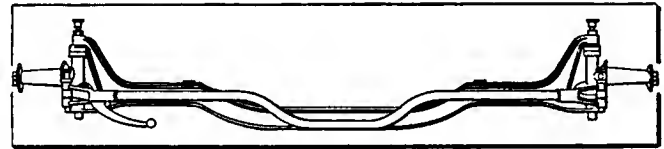

Fig. 9—View of the front axle, together with the connecting rod

- THAT noise in a motor is in most instances a sign of low caste or improper feeding—or both.
- THAT the motor that hums contentedly, like the bee that does likewise, is usually on the job.
- THAT the buyer who takes nothing for granted, but insists upon being shown, need not necessarily be from Missouri.
- THAT the owner of a tonneau is *persona grata* with the neighbors if he "comes across."
- THAT the idea of reforming the maker of a poor product by taking it off his hands is not necessarily a good one.
- THAT you are on the wrong scent when you are not open to conviction.
- THAT each succeeding day brings the automobile nearer perfection; ambition, like a torrent, never looks back.
- THAT a consistently bad performer is a good thing to avoid; it is well to profit by the folly of others.
- THAT the car bought, with the assistance of a catalogue only, without a thorough examination, will in all likelihood soon be a "standing" advertisement of the buyer's gullibility.
- THAT it is just as important to look into the antecedents of the car you are about to buy as it is to have a title "searched" before you invest in real estate.
- THAT your membership in the Sons of the Revolution is no excuse for your being consistent and investing in an automobile of colonial design.
- THAT fortune does not wait at any man's door; she must be sought and wooed before she will surrender.

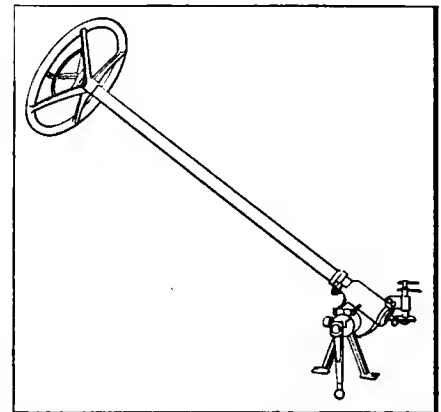

Fig. 10—Showing the steering gear together with the method of attachment and means of operating the control levers

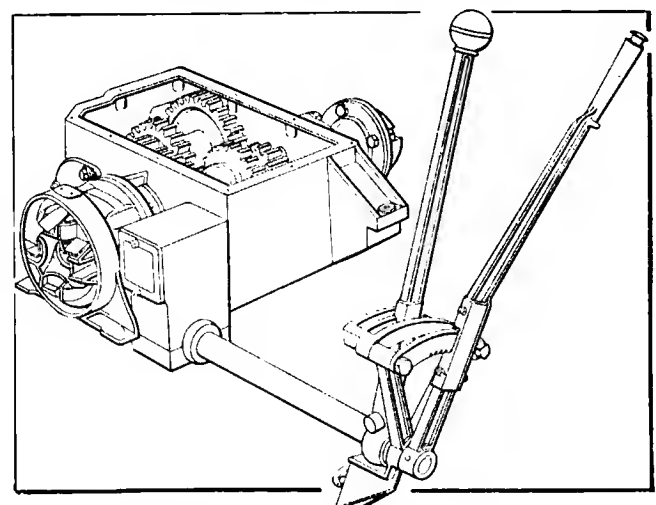

Fig. 11—General appearance of the transmission and levers and the ball-socket joint in which the front end of the propeller tube rests

## A Detail that Designers Overlook

*Like the poor, we always have the starting crank with us, and although self-starting devices are on the increase the old-fashioned starting apparatus has not yet been supplanted.*

A GOOD deal depends upon the way that the starting handle of a car is made as to whether it will be an easy matter or not to turn the motor over for starting purposes.

Preference is given by some to the short lever, and for small cars this should answer very well. But when it comes to a car of 40 horsepower, that in order to turn it at all the average driver has to have resource to the half-compression release, a long lever is preferable. The handle part, or the grip, as it might be called, has not undergone any material change from the time that the first car appeared on the road, perhaps with the exception that it is now made a permanent fitting, whereas in the olden days it was carried in the tool-box out of sight. If this part of the car's mechanism is to combine with the other parts in serving a useful purpose, the grip should be at least 5 inches long, and the part that comes in contact with the hand should be allowed to rotate freely on its axis. The mud and dust that is thrown up by the road wheels will clog the roller unless it is carried in a leather boot, and on most of the modern cars this is done. The end of the handle that is not attached to the lever should be at least 5 inches long, and on cars that require a lot of power to turn the motor over 6 inches is not too long. The end should be slightly lipped so that the hand will not slip off.

In the starting handle, shown in Fig. 1, there is an appreciable slide of the roller R and the gap at S forms a knife edge with the rivet that prevents it from slipping off. Fig. 2 shows a

hand gripping the starting crank, and owing to the shortness of the handle only 3 inches thereof comes into contact with the hand. In the first place this makes it difficult to crank the motor, even were the handle made so that the operator's hand would not be injured in the operation, but in addition to this drawback the sharp edge of the rivet and the roller together pinched the flesh, and, as can be seen in the illustration, Fig. 2, the moment the handle is turned there is a certain amount of outward pressure which tends to draw the roller into tight contact with the rivet.

Fig. 3 shows the operator's hand after starting the motor two or three times. This could have been avoided, of course, by the simple expedient of wearing gloves, but even then the palms of the gloves would be the sufferer and in a very short space of time they, too, would be worn out and useless. When working on a car the hands become begrimed with dirt, and this is carried into the cuts inflicted by the sharp edges. A healthy body may not be affected by this injection of extraneous matter; nevertheless, should the handle by any means be tainted with infection it will undoubtedly be transmitted through the incisions in the palm of the hand, and there is no telling where it may end. The rivet R<sub>1</sub> in Fig. 1 is steel and in a position likely to be attacked by rust, which alone is sufficient to cause blood poisoning if allowed to get under the skin.

Simple matters, such as the one referred to, should be found out by the testing staff of any company, and a report made to the proper quarters so that the defect can be rectified and avoid owners unnecessary annoyance. The time has now arrived when designers who have been spending a good deal of labor upon the general efficiency of the car should turn their attention to detail matters. Buyers are more discriminating and small things that tend for the greater comfort are beginning to appeal to them when they are on the point of buying a new car.

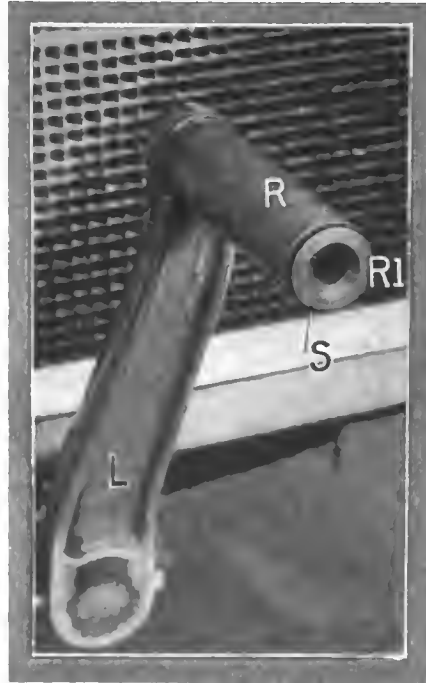

Fig. 1.—Starting handle of a car showing how the roller and the rivet are related to each other



Fig. 2.—Operator in the act of starting the motor, showing how the starting handle is too short and how the roller slides over the rivet



Fig. 3.—The operator's hand after starting the motor a few times being cut by the knife-edge of the starting crank

# Rotary Sleeve Valves Claim Attention

## Several Types Discussed in Detail

*In addition to the reciprocating sleeve valve type of motors considerable attention is being paid on the part of designers to the rotary sleeve valve. The applications are varied and numerous, but it is to be regretted that some designers overlook the effects of the explosion pressure on the valve.*

IT has been the object in the present article to present to the public a diversity of types of motor other than the poppet type in order that a comparison can be made of the different lines along which designers are directing their endeavors. The Henriod and Cottureau appeared at the last Paris Salon in the form of commercialized and tried-out products, and it may be mentioned that they attracted considerable attention. It is apparent from the applications for patents that the majority of the older firms are giving the matter careful consideration, and, although no public announcement has appeared, nevertheless the testing departments are endeavoring to produce something that, besides being novel, will have the qualities of being practical and efficient. The more conservative the firm the longer will the public have to wait for the finished product.

### W. J. Crossley Operates Two Rotary Sleeves in the Cylinder Head

The sectional view of the Crossley motor (AP) shows the manner in which two rotary sleeves are used to control the incoming and exhaust gases. The piston P<sub>1</sub> connected to the crankshaft by the connecting rod C<sub>1</sub> operates in the cylinder C<sub>2</sub>. Within the cylindrical housings, placed above the cylinder head, are two rotating sleeves A and B. Inside these sleeves there are two sleeves C and D and by the slots that are cut in these sleeves the gases pass in or out of the cylinder. The method of operating the sleeves is shown in Fig. AQ. This transverse section of the front end of the motor shows a gearwheel G<sub>1</sub> attached to the end of the crankshaft and meshing with another gear G<sub>2</sub> which is attached to a vertical shaft S<sub>1</sub> rotating in guides G<sub>3</sub>, G<sub>4</sub> and G<sub>5</sub>. End thrust is taken by the ball bearings B<sub>1</sub> and B<sub>2</sub>. The pinion P<sub>2</sub> is in mesh with pinions attached to a pair of the rotary sleeves, causing them to operate in opposite rotation. At the other end of the motor a similar mechanism is provided the inner sleeves D and C. The entire sleeve mechanism runs at one-fourth the crankshaft speed. In order to operate the valves in this motor it is necessary to employ ten gearwheels, which renders it somewhat complicated.

### Split Rotating Ring Is Employed on the Cottureau Motor

The Cottureau motor shown in section in Fig. AR conforms to up-to-date practice in every respect with the exception of the valve mechanism. On either side of the motor the exhaust and intake manifolds are situated, and in order to cover and uncover these to permit of inlet and exhaust a cylindrical ring R<sub>1</sub> is located in the head of the cylinder, or, in other words, the combustion chamber. The ring proper R<sub>1</sub>, and shaft S<sub>1</sub>, together with the boss B<sub>1</sub> can be seen in Figs. AR and AT, also the slot S<sub>2</sub> through which the gases are allowed to pass as the respective ports are uncovered. It will be noticed that the ring R<sub>1</sub> in Fig. AT is split at A and A<sub>1</sub>, which allows for expansion. The rotary ring is operated by means of gearing G<sub>1</sub> attached on the crankshaft to G<sub>2</sub>, whence the rotary motion is carried by the

vertical shaft R<sub>2</sub> to a gear G<sub>3</sub> which drives the gear G<sub>4</sub> through the intermediate pinion G<sub>5</sub>. The vertical spindle shaft S<sub>1</sub> passes through the cylinder head, and to prevent leakage it is beveled at the point of contact with the cylinder head, which is correspondingly beveled.

Screwed on the head of the spindle S<sub>1</sub> is a short transverse arm with a vertical stub which is received into a socket on a corresponding arm attached to a worm wheel carried on a vertical shaft. Lubrication is provided by supplying oil under pressure to an overhead oil bath lubricating the bevel and worm gearing and flowing by gravity down the hollow spindle S<sub>1</sub> and through the hollow transverse shafts T<sub>1</sub> driving the ring to the walls thereof.

### Wridgway Uses a Spherical Valve Driven by Bevel Gearing

The transverse section of the motor shown in Fig. AS represents the method adopted by C. G. Wridgway and is simple in construction. The sphere C operates in such a manner as to place the intake I and the exhaust E in communication with the cylinder C<sub>1</sub> by means of slots S<sub>1</sub> and S<sub>2</sub>. The ports P<sub>1</sub> and P<sub>2</sub> in the cylinders are thus brought into communication with the intake and exhaust manifolds by the rotation of the ball S, which is operated by the rotating shaft R driven by a bevel gearing off the crankshaft, or by other suitable method. The sphere S is fitted with rings R<sub>1</sub> and another which is not shown in the illustration, placed on the cross to prevent the leakage of the gases. The piston P has an extended lip L<sub>1</sub> which covers the port at the moment when the explosion takes place, thereby relieving the valve mechanism of undue strain.

### Broc Motor Utilizes a Double Piston Inside the Working Cylinder

The sectional diagram of the Broc valveless motor shown in Fig. AU is of novel construction. As will be seen in the illustration, there are two pistons, P and P<sub>1</sub>; the outer one P is revolved by a set of bevel gears B and B<sub>1</sub>, the latter being attached to the crankpin on the crankshaft and the inner piston driven in the ordinary way. There are two holes in the head of the inner or fixed piston, one for the intake and the other for the exhaust. In the head of the outer revolving piston there is a single hole H<sub>1</sub> which as it uncovers the holes in the fixed piston permits the gases to be taken in or exhausted. The gases are led to their ports, by means of a helicoidal groove shown, from the carbureter to the intake port of the piston head and through it into the combustion chamber. To accommodate the angularity of the connecting rod, a slide S<sub>1</sub> is formed in the outer piston sleeve for the reception of the fork from the sleeve on the connecting rod, by which it is actuated. The force of the explosion is taken care of by an independent mounting, thereby preventing same from being transmitted to the bevel gearing. This has to take care of the rotary strain alone. The arrows indicate the passage of the exhaust.

### Swift Motor Employs a Horizontal Rotary Sleeve for Each Cylinder to Operate the Inlet and Exhaust

Fig. AV is a cross-section of the rotary sleeve motor constructed by the Swift Motor Company. The sleeve S<sub>1</sub> alternately connects the combustion chamber with the inlet port A and the exhaust port E. The sleeve is driven with half the speed of the engine, and is water-jacketed pretty nearly all over

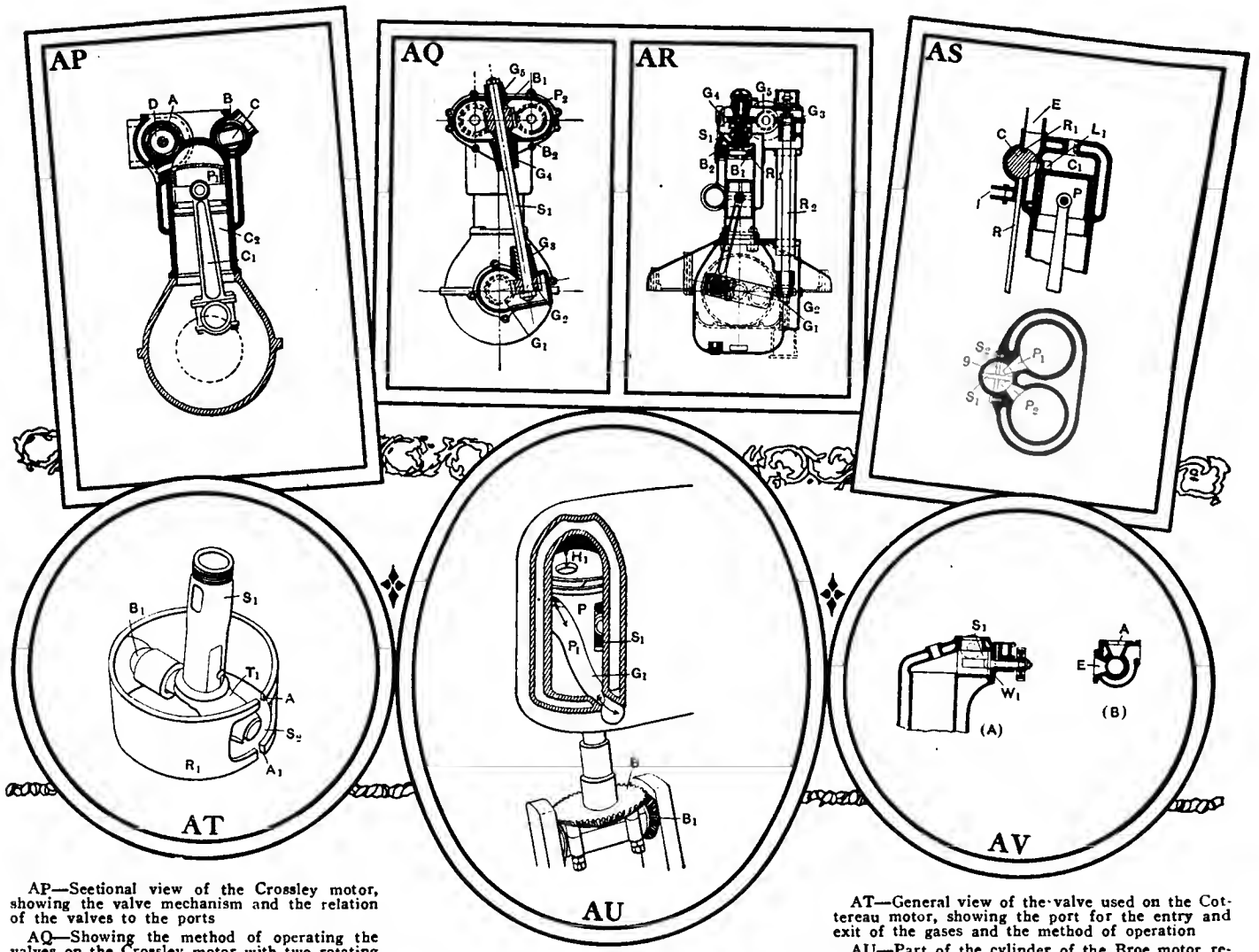

AP—Sectional view of the Crossley motor, showing the valve mechanism and the relation of the valves to the ports

AQ—Showing the method of operating the valves on the Crossley motor with two rotating sleeves in the cylinder head

AR—Transverse sectional view of the Cottereau motor with a split ring valve in the working cylinder

AS—Transverse sectional view of Wridgway motor in which a sphere suitably slotted is employed to control gases. Plan view shows relation of sphere to the cylinder ports

AT—General view of the valve used on the Cottereau motor, showing the port for the entry and exit of the gases and the method of operation

AU—Part of the cylinder of the Broe motor removed to show the method of operation of the two pistons employed and the passage of the gases

AV—Two sectional views of the Swift motor. A—Cylinder head. B—Valve ports

its surface. The tightness of the sleeve is not influenced by the explosive pressure, but this acts upon its back wall W<sub>1</sub>, pressing the same against the cylinder casting.

### D-Form Corliss-Type Rotating Valve Is Used In the Henriad Motor

In the four sections of the Henriad motor the relative positions of the rotary valve in relation to the piston are shown. The valve V runs parallel to the cylinder C in which the piston P reciprocates. As will be seen, the water jacketing is well taken care of and the spark plug is placed in the head of the cylinder. Piston P has a concave dish, and, as shown in Fig. AX, the valve V is relieved of the explosion pressure as the piston P covers up the port hole P<sub>1</sub>, and this takes place during one inch of the stroke, which is four inches in this particular motor. Fig. AW shows the relation of the valve to the piston and the point where the exhaust has closed and the intake is about to open, the exhaust manifold being shown at E and the intake at I. Fig. AX indicates position of the valve on the firing stroke, showing the port P<sub>1</sub> covered by the piston. Fig. AY shows the piston at the lower dead center and the exhaust port E about to be placed in communication with the port P<sub>1</sub>. Fig. AZ shows the port P<sub>1</sub> and the port P<sub>2</sub> giving free passageway to the exhaust gases that are being expelled by the upward sweep of the piston. The lubrication of the valve V, shown in Fig. AX, is taken care of by the pipe P<sub>11</sub>, which is in direct communication with the pressure feed system.

### Richards Employs a Reciprocating Piston Inside the Working Cylinder to Operate the Valve Ports

This invention (British patent No. 28,767), registered by J. H. Richards and B. Bellingham, relates to the valve mechanism for controlling the inlet and exhaust gases of a four-stroke cycle type motor. Referring to the sectional view of this motor as shown in Fig. BA, the sliding piston P<sub>1</sub> is employed, which is solid or undivided, having passages leading between the upper and lower faces so that it does not exert any binding or braking effect on the cylinder walls. The rod R is operated by means of a cam mechanism, a spring being interposed between the roller and secured to the rod R to maintain the tension of the roller on the cam surface. The sectional view is of the upper end of the engine cylinder C<sub>1</sub>. The piston valve P<sub>1</sub> is fitted with a ring R<sub>1</sub> engaging with the walls of the cylinder, and is provided upon its upper side with a central cylindrical stem S<sub>1</sub> which passes through and is arranged to slide within the cylinder head C<sub>2</sub>, the upper end of the said extension S<sub>1</sub> projecting above the head and being connected up to the actuating mechanism. Expansion rings are fitted to the trunk extension S<sub>1</sub> so as to maintain a gas-tight joint. Passing through piston valve P<sub>1</sub> there are a number of passageways P<sub>2</sub>, while upon the upper face are segments of an annular rib which, when the valve is fully lifted, comes against the under side of the cylinder head. Near the upper end of the cylinder leading to the valve space or chamber is an exhaust port P<sub>4</sub>, and an admission port P<sub>3</sub> is provided in the upper end of the cylinder head, the inner end leading into

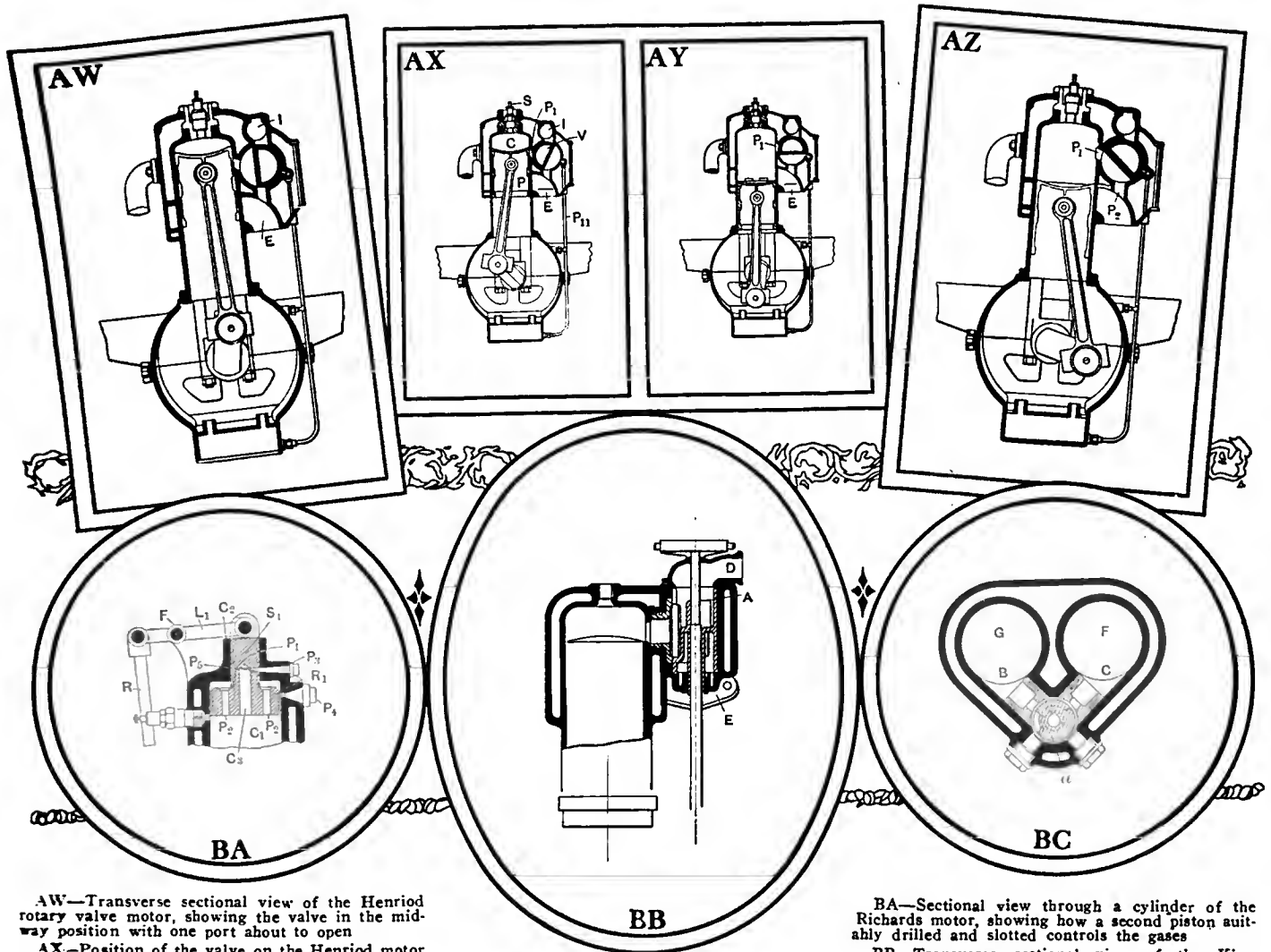

AW—Transverse sectional view of the Henriod rotary valve motor, showing the valve in the mid-way position with one port about to open

AX—Position of the valve on the Henriod motor during the compression stroke with both ports closed

AY—The piston is near the lowest point of the stroke on the Henriod motor and the valve is about to uncover the exhaust port

AZ—Position of the valve during a part of the exhaust stroke on the Henriod motor. The lubricating pipe for the valve can be seen at the right, leading from the base

BA—Sectional view through a cylinder of the Richards motor, showing how a second piston axially drilled and slotted controls the gases

BB—Transverse sectional view of the King motor, in which a rotary sleeve valve is employed for each pair of cylinders

BC—Plan section of the King motor, showing the ports in the cylinders together with the rotary valve

the central hole in the latter, within which the valve stem *S1* reciprocates. Arranged to co-operate with the inlet port *P3* is a port *P5* formed in the side of the valve stem which leads into the central chamber *C3*, passing axially through the stem and piston *P1*. The lever arm *L1* fulcrumed at *F* to a lug on the cylinder head operates the piston valve. The cam that operates the rod *R* is so formed as to permit of periods of dwell.

### King Motor with Single External Rotary Sleeve for Each Pair of Cylinders

In the King motor, a cross-section of which is shown in Fig. BB, only one rotary sleeve is provided, which serves a pair of cylinders arranged in the manner seen in Fig. BC. The sleeve, which rotates with half the crankshaft speed, is driven by means of a shaft and a set of bevel gears, and the openings *B* and *C* in the sleeve owing to their magnitude permit of rapid opening and closing of the cylinder ports, they serving to connect the inlet *A* and the exhaust passageway *E* with the respective ports of the cylinder. In Fig. BC is seen the first stage of scavenging for the cylinder *F* and the beginning of the suction stroke for cylinder *G*. An oil lead is provided alongside the sleeve.

THE trend of events points to the future better understanding of the radiator problem and to the fact that carbon is formed in the combustion chamber of the motor if the radiator fails to do its part.

## Live Axle Makeshift Repair

IT is often found that the V-shaped stay under a live axle will break, and after being repaired in a short time will break again. A careful examination of the axle will disclose the fact that it is out of line and has worn the differential housing so that the axle tubes are loose in this casing.

If the axles and casing are both too thin to be turned down far enough to admit a bushing, the axle tubes may be wedged into the casing by means of strips of thin sheet steel so as to be very tight. The axle is then stiffened by means of a plank which should be 1 1-2 inches in thickness. A suitable wood for the purpose is ash. The top edge of the plank is placed along the bottom of the axle and cut to fit from end to end, the shape of the gearcase being cut from the plank to allow the plank to bear tightly against the casting. The plank is supported and held against the axle by means of four inverted U-shaped straps which hang over the axle. Slots are cut through the plank in the proper positions so as to admit cross pieces which pass through the plank. These cross plates, which are about 3-8 in. in thickness and about 1 1-2 in. in width, are drilled to take the 3-8 in. diameter straps. Bolts and lock nuts are placed on the ends of the straps and drawn tightly home. To strengthen the lower edge of the plank two flat bars of iron, 1 1-4 in. width and 1-4 in. thick, may be bent to the shape of the bottom of the plank, which is sawn so as to taper toward the ends. The iron is bolted on with 1-4-in. bolts.



# Shortcomings of the Average Body

## Stock Bodies Are Often Uncomfortable Contraptions

*As cars are sold at the present day the buyer has little opportunity to make provision for his personal comfort, and many an otherwise pleasant tour is turned into a nerve-racking trip by want of forethought in body building and equipment.*

WITH the practice of selling cars fully equipped, buyers are compelled to take things just as they find them, and if they have any particular ideas of their own as to the requirements to suit their particular needs, in the majority

the running boards could be denuded of tool chests, tire-carriers, and the like. The system in vogue on the Continent of selling the chassis and leaving the coach work in a measure to the buyer to decide has material advantages from the point of view of comfort afterwards; but, nevertheless, it is a good deal more costly to have a special body built than to take one of the stock models that are built by the hundred.

The advent of the fore-door has done much to render the front compartment more comfortable and the body more sightly. In the aim for comfort, some body designers overlook a pleasing



Fig. 1—Showing how side doors are made to open on the Chalmers, with levers placed so that driver can get in without disturbing passenger

of cases the body has to be rebuilt in order to accommodate them. There is no reason why a body should not be so built that

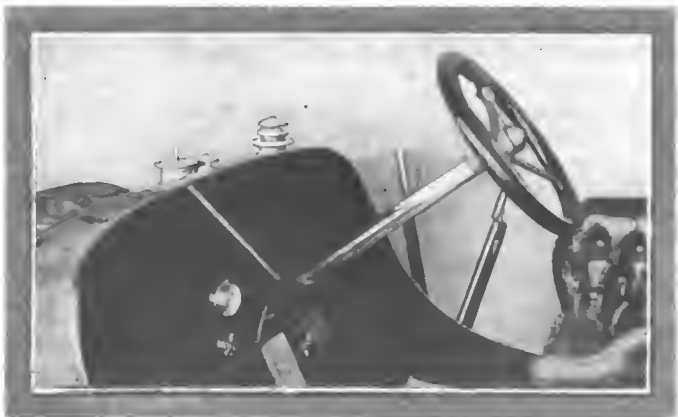

Fig. 2—Cowl of the dashboard used as a gasoline tank, with a recess cut away for the pedals, but the levers are placed very far forward

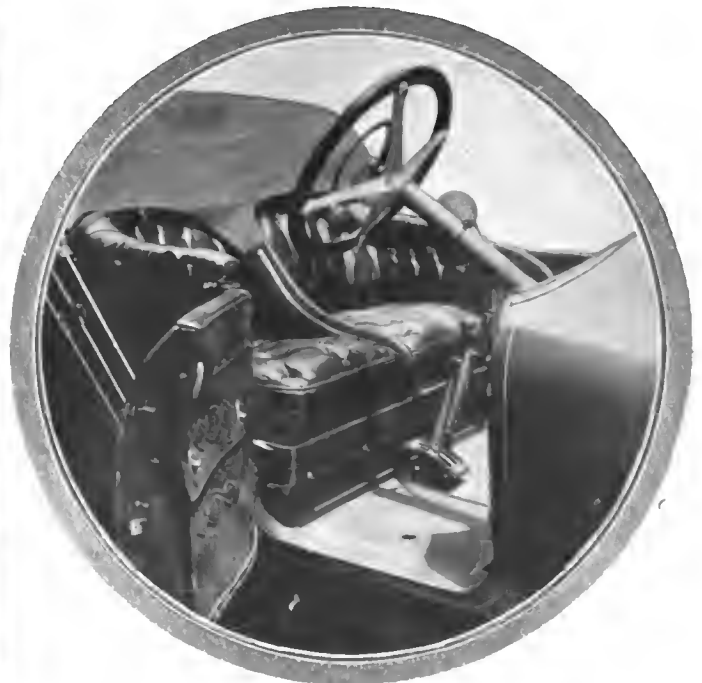

Fig. 3—Entrance to driver's seat made easy on the Overland by placing the gear and brake levers in the center

aspect, whereas it should be their aim to make a combination of these two most desirable features. In Fig. 1 can be seen the method employed on the Chalmers roadster permitting the driver to enter the car on the right-hand side through a door which is made to open. This is effected by placing the levers sufficiently far forward so that they do not block the passageway. Although coach-builders may be blamed for some of the lack of comfort in the bodies that they turn out, nevertheless, if they have to build a body upon a chassis that is not suited for the purpose, the blame does not rest entirely at their door. It would be a good plan if manufacturers of cars were to take the gear-shift and brake levers into consideration, and make provision whereby the steering pillar could be raised or lowered by an adjusting device. With a fixed steering pillar, or one that necessitates the dismantling of the motor, fitting new brackets, or re-drilling the old ones, cannot be expected to suit everybody that sits behind it. The same applies to the pedals, and it is curious to see how some people will go through contortions and even body discomforts, whereas by lengthening or shortening the pedals, as the case may be, they could be made to suit the requirements of the driver.

The method adopted in Fig. 2 of raking the wheel considerably, and fitting the front seats low down, tends to add comfort to a long day's drive, but in this instance when the coach-builder has endeavored to do his part of the work satisfactorily he is thwarted by the chassis-maker in so far as the levers are placed almost out of his reach. This illustration tends to show that there must be co-operation between body designer and chassis-builder. Of course the levers could be linked and bent back near the reach of the driver's hand, but after all is said and done this is only a makeshift and gives the car an unsightly appearance. What is required in this case is that the bracket carrying the levers should be given a rearward incline, and the keys that hold the levers to their shafts be reset. While studying this illustration one good point will be noticed; the dash has been left particularly free. The cowl, which is made fairly wide, has been turned into a receptacle for a capacious gasoline tank, and the side facing the occupants has been neatly finished off with a mahogany covering to which the switch and pressure gauge have been attached. The right side of the dash, as will be seen in the illustration, has been cut away, leaving plenty of leg room for the driver to operate the pedals, and instead of leaving the rub-

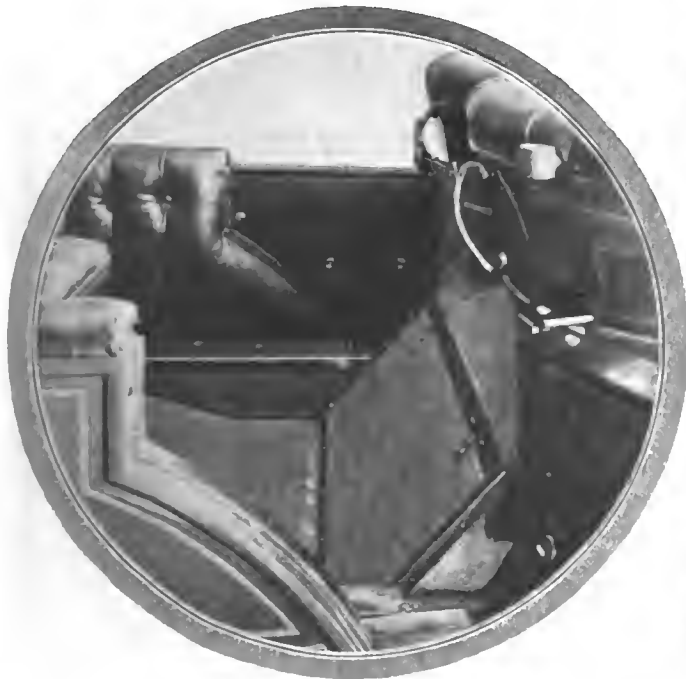

Fig. 4—Tool box and foot rest on the Speedwell car which does away with boxes on the running board and gives comfort to the passengers

ber mat below the driver's feet unprotected to the constant wear a piece of patent leather has been sewn onto this portion.

A change that is taking place in chassis design, and one which gives the body builder more scope, is shown in Fig. 3. Here it will be seen that instead of placing the levers so as to be operated on the driver's right hand they are placed centrally, leaving the passageway when the door is open free for the driver to get in and out without disturbing the other passengers.

In the days when horse-drawn carriages were in vogue it was usual to have a driver and footman on the box, but now that the footman has been dispensed with in the case of the automobile and the available seats are occupied by the owner and his friends, such provision as this is a great help for the driver to get out quickly in order to open the door of the rear compartment. Runabout bodies, for the most part, offer great possibilities to the coach-builder, but the manner in which tops are fitted to this type often renders the appearance far from pleasing. The suction created by an automobile in passing through the air usually causes a back-draft with the consequence that unless the back of the car is sufficiently high dust and mud will be thrown on the backs of the passengers. By fitting a second

Fig. 5—Arrangement on the rear of the Overland runabout for carrying the gasoline tank, tool box and spare tire. The lowered top also improves the appearance

bracket for the top, as shown in Fig. 3, the irons can be dropped, and besides being more sightly the back-draft is obviated. Ref-

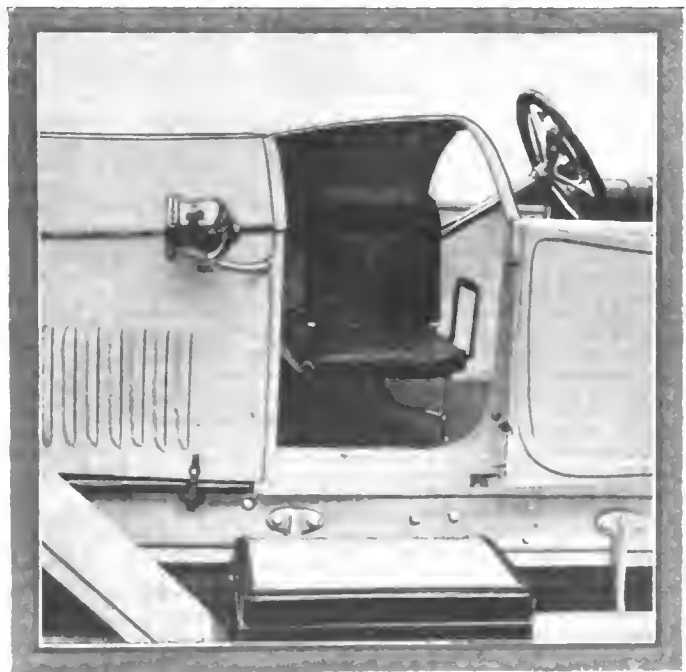

Fig. 6—Method of utilizing the waste space under the large cowl for the extra seat, which can be folded away if not required and the cowl closed

erence was previously made to the question of eliminating tool-boxes from the side platform steps, and the method adopted by the Speedwell Company, as shown in Fig. 4, is worthy of notice. Considerable attention has been paid heretofore to the driver's seat and to the happy possessors of the front compartment of the car, but, beyond some refinements along the line of fittings and upholstery, the passengers in the rear of the car have been left severely alone. Anyone who has sat on the rear seats of a car has experienced the uncomfortable slipping sensation, not to say insecurity, while driving over bad roads, and this is due in a large measure to the poor foothold afforded. Immediately behind the front seats in this illustration will be noticed an inclined box capable of containing a goodly number of tools and spares, but which, when closed as shown, affords a resting place for the passengers' feet; the purchase thereby obtained adds considerably to the comfort of the occupants. One disadvantage that this brings with it will be noticed by the slightly restricted passageway, but this should be set against the comfort while driving, and, if anything, the advantage is for the latter.

The chauffeur is a necessary evil to some autpists who either do not wish to attend to their own cars or who drive for the

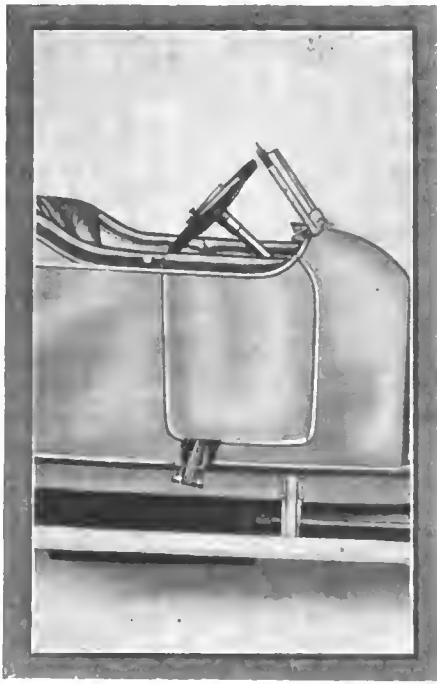

Fig. 7—Another example of utilizing the dash cowl for a gasoline tank, with the filler behind the slanting windshield

sake of driving and have not taken the trouble to master the intricacies of the mechanical parts. Then, again, there is the question of tire trouble and the owner would sooner carry a man to attend to them than do so himself. The question then arises where to put him, and the solution is either that he sit alongside of the driver or on a small dickey on the foot-board. In the majority of present-day roadsters the rear of the driver's seat is occupied by a gasoline tank, luggage, and tires, which prevents the dickey being placed in this position. If the two seats are occupied by the driver and a passenger, the dickey has to be resorted to, unless some such provision is made as shown in Fig. 6. The cowl is made in two sections, one half being caused to slide under the other, and the extra seat, which can be folded and stowed away when not in use, is brought into service and the chauffeur provided with a seat in the manner shown. When the extra seat is not in use the appearance of the car is not marred by a permanent fitting, as the cowl is entirely closed in the manner previously indicated and a door is provided to complete the fore-door effect. A separate door, of course, is used to obtain entrance to the driver's seat.

The appearance of the rear of the car as shown in Fig. 5 is not at all displeasing, and the gasoline tank, tool box and spare tire are taken care of in a simple manner. This illustration also shows how this has been made possible by dropping the front ends of the top stays. Previous mention has been made to the feature of carrying the gasoline tank under the cowl of the dash, and Fig. 7 offers another example of this. The filler cap, instead of being placed

in the dash proper, has been carried behind the windshield, which latter can be pushed forward while the tank is being filled. This type of front compartment is very comfortable, as the seats are placed as low as possible and the driver's head does not come above the level of the back rest. The levers in this instance are placed very low down and it has been found necessary to



Fig. 8—Dashboard in a closed car, fitted with a glass window to permit the driver to properly see the dash fittings

break the lines of the body in order to accommodate them. A little forethought on the chassis-builder's part might have obviated this.

Now that closed cars are being used more largely, it is necessary to adopt some provision other than electric light to permit the driver to see the gauges that are placed upon the dash-board. In Fig. 8 the top part of the dash has been fitted with a glass window, allowing the light to enter and shine upon the fittings. Provision has been made in this body to permit the driver to tilt half of the glass screen forward in order to obtain a better vision on a rainy day, or to allow a passage of air into the compartment when the body is used as a closed car. Fig. 9 shows how the dash-

board cowl can be extended and a windshield placed thereon just above the steering wheel, the type as shown in Fig. 8 being hinged at the top so as to swing outward from the bottom. The extension of the top is carried over the dash and under these circumstances it would be almost impossible for rain to enter. Figs. 10 and 11 show the cowl extended, the sloping bottom half being made either of leather or glass insert and capable of being laid down as shown in Fig. 10 or raised as shown in Fig. 11. It will be noticed in Fig. 11 that there are locking hinges at the top, and using these as hinges the screen can be tilted forward.



Fig. 9—Cowl extended so as to bring the windshield closer to the driver and the top given an extra extension for better protection

An extended cowl, such as is shown in Fig. 12, offers some difficulty in the fitting of windshields, but this has been overcome in the manner shown. Locking devices are fitted to the base of this shield so that it can be used as a wind deflector when placed in the manner as seen in the photograph, or in a vertical position, so that the turn buttons that are screwed thereon can be attached to the extension of the top, thereby excluding all rain.

## Gasoline-Electric Passenger Service

*After years of experiment and disappointment with different methods of propelling the small passenger vehicle to take the place of the dirty and unsatisfactory small locomotives and cars, the "automotrice" has made a hit abroad, and seems to have come to stay. This is a car operated by electricity which is generated by a gasoline motor.*

THE greatly varying conditions in Europe which confront the builder of a passenger vehicle seem, after a long struggle, to have been at last solved to a certain degree by the installation of the gasoline-electric car, generally termed "automotrice." The most notable installations have been made in Hungary, Germany, Holland and France. England and Sweden,

after having carefully watched the success of these cars in the countries in which they have already been in operation, have also placed orders for several of them.

The first experiments in the direction of self-propelled cars were made with steam motors. These proved to be very hot and uncomfortable in the summertime; the smoke and dirt present also being very annoying. The next step was in the direction of a gasoline motor-driven car. This was brought about by the great progress in the automobile, and it was expected that the gasoline motor could be adapted to the requirements of short-distance passenger traffic. The latest experiments turned toward the gasoline-electric cars, which, from the results recently achieved, give the idea that the problem has been, to a large degree, solved.

The success of the gasoline-electrics can be attributed to the following: Simplicity, due to the fact that the apparatus has been

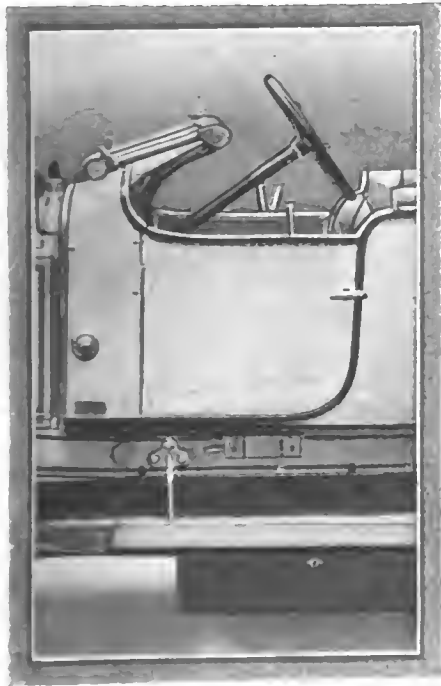

Fig. 10—Extended upswept dash with the windshield folded forward, giving the driver clear and uninterrupted vision

cut down to an elementary form, consisting of a gasoline engine, directly connected generator and secondary motors on the axles of the cars, giving a direct drive to the wheels. Reduction of weight is also a factor in the success of these cars. The modern automotrice, with a seating capacity of 40 passengers, will not weigh more than 20 tons, while an American electric car would weigh about double that amount. The power equipment of the European vehicle would be either a 60 or 90-horsepower generator group which, in a car of this weight, will give it a speed of from 25 to 40 miles per hour on level ground.

The commercial returns of the investment have been excellent, one line showing \$100,000 annual profit.

## When Judgment Whispers Don't

- D**ON'T judge a car by its reputation alone; its character should also be taken into consideration.
- D**ON'T forget that the best set of brakes in the world are of little use unless applied at the proper time and with judgment.
- D**ON'T fail to remember that a well-cared-for automobile is a potent illustration of the virtues of reciprocity.
- D**ON'T forget that the monotonous regularity of a well-performing motor may be broken by the judicious application of a poor quality of lubricating oil.
- D**ON'T overfeed the motor—dyspepsia and loud retching noises are bound to follow over-indulgence.
- D**ON'T neglect the hour of preparation that may insure the week of touring delight.
- D**ON'T waste sentiment upon a motor—lubricating oil may be what it needs most.
- D**ON'T discriminate against the motor in your automobile unless you desire to be paid in kind.
- D**ON'T forget that the product of a well-matched team is always good.

- D**ON'T forget that perfunctory preparations for a tour will surely spoil your pleasure.
- D**ON'T look down upon the pedestrian; he may have tired of automobiling, and is waiting for his new aeroplane to be delivered.
- D**ON'T, if you are a freight automobile salesman, dilate too enthusiastically upon the superiority of your wares over the customer's horse-drawn equipment.
- D**ON'T allow him to hope for results unless he consents to the establishment of a well-equipped service.
- D**ON'T forget that a failure to show results is worse than not to have made the original sale, for you have lost your future market in so far as that client is concerned.
- D**ON'T drive the second nail until the first is clinched.
- D**ON'T take for Gospel all that the glib salesman tells you; the salesman must "know" even if he has to fabricate.

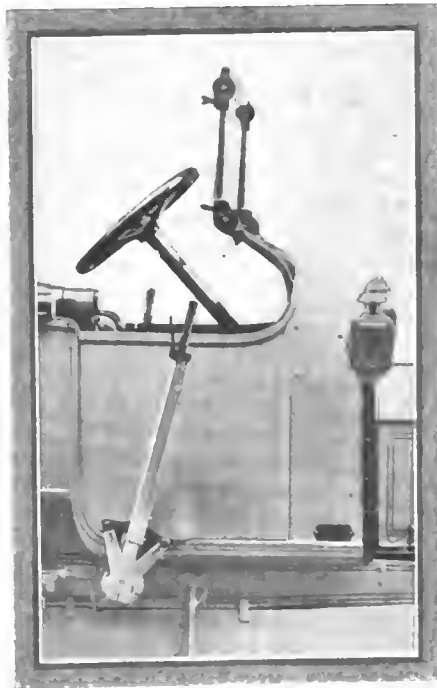

Fig. 11—Dash similar to the preceding with a windshield that offers the driver the option of opening it from the top by swinging the bottom forward

- D**ON'T violate basic principles in building up a plan.
- D**ON'T attempt to demonstrate the straight-line axiom when there is a telegraph pole or a wire fence in the way.
- D**ON'T despise a horse when you can't get your car out of the mire in any other way.

**CANADA'S CARRIAGE MAKERS TURN TO THE AUTOMOBILE**—To gain a graphic idea of the growth of the automobile industry as it obtains in Canada, one needs but to take a walk among the shops formerly devoted to carriage body building. Judging by the attitude of the men who conduct these industries, it is evident that the manufacture of horse-drawn vehicles no longer affords the mechanic the same opportunity to earn his bread that it did a decade ago.



Fig. 12—Method of fitting a top to a curved cowl. The shield is fitted with a locking device whereby the position can be altered at will

# Cooling and Efficiency

## Suggested Improvement of Present-Day Engines

*Without being specific and giving composite data to those who are looking for increased efficiency, the following article, which appeared recently in "La Technique Automobile et Aérienne," points out some of the advantages and disadvantages of present-day motors, and to improve efficiency the suggestion is given that higher compressions will furnish a solution of the problem. In dealing with the advisability of dispensing with the cooling system the author believes in sticking to the evils that we have rather than fly to others that we wot not of.*

**D**ESPITE the great amount of work that has already been accomplished, unity among the diverse types of thermic motors is far from being realized. The steam engine, contrary to the predictions that were made on the appearance of the gas motor, continues to merrily carry the handicap of 600 calories lost in vaporization.

This is reduced from time to time by increasing the compression, as well as by superheating, water-jacketing, and above all by the condenser. Its suppleness, security in operation, and easy-starting qualities, together with its reversibility, render it without doubt—at least for some time to come—a necessity for locomotives.

On the sea in the case of large ships the turbine is its only rival. But this type of motor, if it competes with the older type of piston motor, strengthens the position of steam in comparison with industrial motors of the internal combustion type. These latter, with the exception, perhaps, of specially constructed powerful motors utilizing the residual gases of the blast furnace or the coke furnace, are generally employed in installations of medium power. And even for such the steam engine is holding its own, and the recent application of the central exhaust on single-cylinder condensing engines is not favorable to the extension of explosive motors.

In several instances, however, they have a manifest superiority which is incontestable. But for aviation internal combustion motors were not indispensable, for the contrary was shown by the experiments of Ader. But they are expanding rapidly into other fields, such as submarine work, and for fishing boats, and the suggestion has even been made to equip fairly large vessels with them.

But if the two great types of thermic machines have in their own special fields a justifiable vogue, nevertheless there is a competition raging in many others. The motor that will win out in the long run will be the one that has the greatest efficiency, using this term in the broadest sense of the word, and not including in it only the question of consumption of new parts and repairs, but also the expense of running or of difficulty in keeping same in order. The author states that he is one who believes that the future holds great things in store for the explosion type motor, and endeavors to show a small side of the problem that is paramount in the minds of the industry—the search for high efficiency.

It would seem, in looking at the imperfections of the motor of the explosion type, that the greatest of these lies in the cooling problem. It is found that water absorbs some 40 per cent. of the calories that are contained in the combustible. From this alone it is seen that it is impossible to work a piston in a cylinder above a certain temperature without suffering loss of efficiency.

This is subject to modification. But supposing that **without** modifying its general properties one were to construct a **motor** in which the two following conditions were obtainable, it **would** be said that such a motor was only theoretical:

(1) that the piston remain airtight and in good working order no matter what temperature it was called upon to work under;

(2) and at these temperatures self-ignition of the mixture was not a thing to fear—

All other properties of this motor being the same as those of an ordinary motor as at present constructed.

It ought to be pointed out in the first place that adiabaticism due to the walls is hardly possible of attainment even if the exterior of the cylinder is fitted with a thick layer of heat-retaining material. It does not suffice to attain the adiabatic condition by preventing the heat from passing through the thickness of the cylinder. Another difficulty to be overcome is the prevention of the walls storing heat until a certain moment, to give it back in the next moment—a problem which is more difficult of accomplishment than the first.

Let us compare the phenomena that take place in the motor as above described with those produced in an ordinary type of motor having the same characteristics, but which is cooled. Presuming that an equal amount of combustible mixture is taken in each cycle by both motors, the pressure diagram will be slightly higher in the uncooled motor than in the other on account of the difference in the temperatures. But this advantage, although small, is perhaps completely destroyed by the detrimental action of the walls. These absorb some heat during the expansion stroke or at least at the commencement of it. They give this heat off to the burnt gases during the exhaust stroke; they heat the mixture during the suction and compression strokes—all harmful phenomena which without doubt will compensate for the small amount of gain that will be shown later. This heat that is carried off in the cooling is only utilized in a very small degree by the second type of motor. In addition the heat is carried off by the gases through the exhaust, which leave at a much higher temperature. Therefore the cooling is not a bad application in itself, because if a means were found to dispense with it, all other things being equal, the calories of the combustible could not be utilized to better advantage. It is not a question, therefore, of the losses caused by the imperfections of the mechanical working of the piston, but rather a loss of a cycle, and it is along these lines that improvement should be directed.

For that end one and only one method is available, and that is by augmenting the compression. The more the compression is augmented the lower will be the mean temperature of the gases, consequently less unused calories will be carried off by the water. Diesel takes advantage of this phenomenon and proposes a motor with high compression without cooling. The kerosene motors that he has turned out so far are an experimental proof. These lose to the cooling water per horsepower hour about one-third of what is lost in the same manner by ordinary explosion motors with much lower compressions. Whereas these types rarely ever attain a 25 per cent. efficiency, the Diesel often betters 35 per cent. for large power plants. On the other hand, if the simple augmentation of the compression permits this important loss to be minimized, as we have just seen, it is useless to pass from the cooling to some other manner, because there would not be any economic advantage. It would seem to be a relatively easy matter to imagine some mechanical disposition that would permit a piston to work in a cylinder under high temperatures, and it is proposed



to return to this later. But, as we have just seen, the solution of such a problem is void of interest.

No matter from what side the question is viewed, it will be necessary for those who wish to build internal combustion motors of great efficiency to follow the ordinary practice in the employment of high compressions. It will be impossible to use the "explosion" motor above certain limits, the degrees of which will depend on the weakness of the mixture, on account of self-ignition. Then the Diesel type of four-cycle motor for liquid or pulverized combustibles will be used, or the Gardie type of two-cycle for gaseous combustibles or even for the others.

The Gardie motor is to the gas variety what the Diesel is to the kerosene. It is to be regretted that the trials of this type of motor were not carried out further, as no doubt it would have given excellent results. Unfortunately the few tests that were made were only with compressions that seem very low at the present day. Such a motor is perforce fairly complicated, and is not interesting for that reason.

The growth of compression must have a limit, and in order to understand this one has only to think for a moment of the inconveniences that would be engendered by an exaggeration. All the working parts would have great strains to support and would have to be reinforced. A piston submitted to excessive pressures rapidly renders the cylinder walls oval; it would be difficult to overcome this by lengthening the connecting rod because it would soon become formidable.

If the price of a machine for a given power varies in an inverse ratio with the efficiency; a limit would soon be attained above which there would be little use in going. On the other hand, the interest presented by the increase of efficiency lessens as this increases. An augmentation from 10 to 15 per cent. will furnish an economy on the combustible primarily employed of one-third, whereas if the machine already has a 25 per cent. efficiency and by bringing this up to 30 per cent. one would economize more than one-sixth of the primary combustible. It will be noticed that this is less than in the first case cited, on account of better efficiency, and it shows that the absolute economy realized in passing from 25 to 30 per cent. is not more than one-fifth of what can be obtained in passing from 10 to 15 per cent.

This is why one would stop short in the research for high efficiency much below the figures of the Carnot cycle. And when all motors have attained a sufficiently high efficiency for the purpose for which they are intended, the industrial choice will no longer be guided by matters which seem almost of secondary importance in certain cases, such as simplicity, regularity in running, cost price, durability, and so on, although such considerations have a good deal more importance than some people attach to them. Now to deal with the subject previously referred to, viz., the working of a piston in a cylinder of an uncooled internal combustion motor. According to the author, there

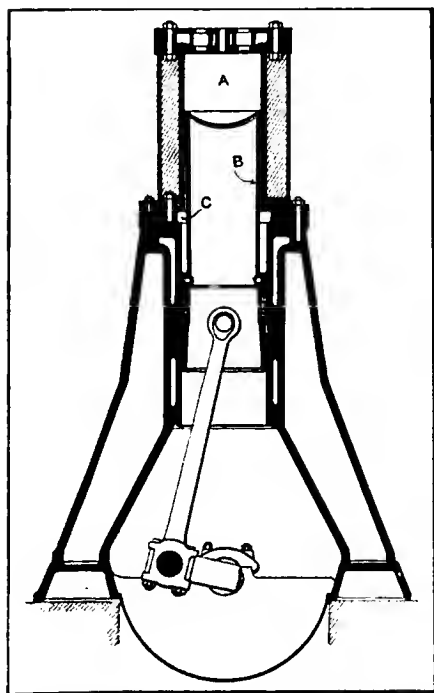

Sectional view of a motor referred to in which a double piston and cylinder are employed in order to obtain a piston that will operate in a cylinder at high temperatures.

should be no difficulty in obtaining such a condition. It would not be possible to retain the type of piston that slides easily in the cylinder. One could employ a piston similar to that shown in the accompanying illustration, with a diameter slightly less than the cylinder, without any point of contact between the two members.

By this means we would have a second piston and a second cylinder forming part of the main cylinder and joined thereto. It works at low temperatures because between the hot part of the motor A and the lubricated piston there is an annular body of gas B which will prevent the heat from being transmitted. It remains to provide that these gases shall not be in constant motion, and this can be arranged by calculating the different diameters and the volume in the space C so that the pressures at A and C shall remain practically constant. Cold air could be injected at C which would prevent the piston as well as the airtight cylinder from heating.

This principle has been employed by different inventors, among whom may be mentioned Gardée. It may be noticed that a large number of inventors set themselves to the task of solving oftentimes arduous problems without perceiving that there will be little utility gained thereby. The preceding example is among this class; nevertheless it might be worthy of consideration in the case of pulverized combustibles. But that time has not yet arrived.

## Changes in Thermal Efficiency

*The products of the exhaust form the greatest clue to the thermal efficiency of the motor. These products change under different load conditions and for this reason the thermal efficiencies vary with the load.*

FOR a given motor there will be a certain load at which the combustion in the cylinder will be most complete and the exhaust will contain the minimum amount of combustible material. The greatest heat value will be obtained from the fuel when the greatest amount of carbon monoxide has been burned to carbon dioxide and the greatest amount of hydrogen has been consumed. Hence the presence of an excess amount of carbon monoxide and free hydrogen in the exhaust shows that the motor is working at a low thermal efficiency.

Taking an average case it will be seen that under full load the amount of carbon monoxide present will be 3.31 per cent. of the total volume of all the exhaust gases and the hydrogen 1.19 per cent., while with part load the carbon monoxide was 6.9 per cent. and the hydrogen 2.4 per cent. The free oxygen in both cases was very nearly the same, figuring on a percentage basis showing that under all conditions an excess of oxygen above the theoretical amount necessary to combine with the fuel is required. It is impossible under the conditions we are at present working to secure what might be called a perfect exhaust, that is, an exhaust in which there will be no trace of uncombined fuel, but there is a field here for the designer to raise the thermal efficiency of the modern engine by a partial removal of this source of loss. The other heat losses seem to be a necessity since we cannot dispense with a cooling agent of some sort, nor can we have a bearing in which there is not some loss due to the heat of friction. There is a load condition, however, under which the loss due to unburned gases in the exhaust will be a minimum and the thermal efficiency a maximum. The conclusion to be drawn from the fact that working under a reduced load is working with reduced efficiency points out the bad economy of overpowered plants.

SOME of the German tire manufacturers give a guarantee on tires "for 10,000 kilometers, to be run within twelve months from the date of delivery," under conditions which restrict the heft of loads.

### Removing and Replacing Piston Rings

Editor THE AUTOMOBILE:

[2,761]—I intend to take the piston rings from my motor and clean them. Before starting to work, however, I would like to have full and detailed information as to how to go about removing the rings and returning them to their proper positions in the piston. If you could supply me with the desired information I should be very much obliged. I wish to start upon the work at once and would appreciate an early reply through your columns or by mail.

A. W. SCHEDE.

Islip, N. Y.

There are several good methods in vogue to remove the piston rings without doing them any damage. One of the best and most practical ways is to take a piece of stiff copper wire flattened at one end and insert it beneath the ring at the cut. The ring is then pried up by means of the wire until it is lifted clear of the groove. A piece of brass about one-half inch in width and two inches in length is slipped beneath the ring, thus forming a bridge across the groove. The accompanying cut, Fig. 1, shows the first strip of brass inserted. Other strips are inserted in the same manner all around the ring, which can then be slipped off the end of the piston.

The rings are replaced in the same manner, the order of procedure, of course, being directly opposite to that of the removal of the rings, care being taken to put the rings back into their proper positions and not to bend them too far, as they are brittle and easily broken.

### Trying to Blow Up the Muffler

Editor THE AUTOMOBILE:

[2,762]—As I am a constant reader of your paper I am taking the liberty to

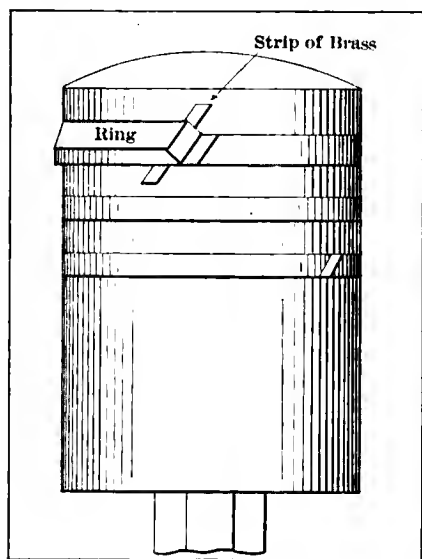

Fig. 1—Showing strip of brass inserted under piston ring in order to slip the ring off the piston

## What Some Subscribers Want to Know

ask your advice on the best way to go about curing the trouble to which my motor is greatly addicted. Every once in a while a series of explosions will take place in the exhaust pipe and muffler as if the engine were doing its best to put the muffler out of commission. I should like to know what the causes of these muffler explosions are and if they are dangerous?

K. M. KARCHER.

Portsmouth, N. H.

Explosions in the muffler are in every case due to the presence of unburned gases which have passed through the exhaust pipe owing to misfires in one or more cylinders. The unburned gases pass through the exhaust line into the muffler and are ignited by incandescent particles of carbon or metal or by the heat of the exhaust of the next explosion in the cylinder. These explosions are not as a rule dangerous as far as bursting the piping is concerned, but in an enclosed garage

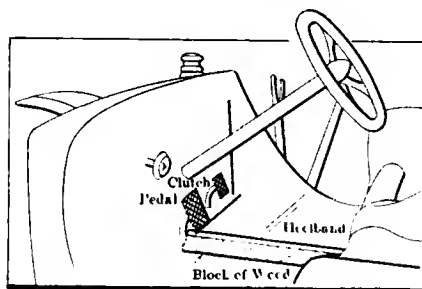

Fig. 2—Method of blocking back pedal while repairing the clutch

where there is gasoline vapor in the air, they may be the cause of starting a serious fire.

### A Trip to the Repairman Necessary

Editor THE AUTOMOBILE:

[2,763]—I am very much bothered by the cooling water boiling in the radiator and by back firing while running slowly. Would you kindly tell me if these have any bearing on each other and how they may be prevented.

OLD SUBSCRIBER.

Bath, Me.

There is no doubt something wrong in the water circulating system which is responsible for all the trouble. Through not being sufficiently cooled the combustion chamber becomes over-heated and causes pre-ignition, and the backfiring is directly traceable to this.

### In Trouble with a Biting Cone Clutch

Editor THE AUTOMOBILE:

[2,764]—I am having a great deal of trouble with the clutch on my car. When

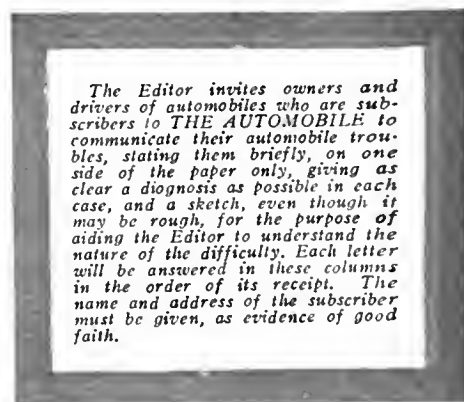

I close the clutch gradually it will suddenly seize or bite. It is a cone friction clutch, leather-faced, and has given trouble for some time, although before that it worked perfectly well under all conditions. I would be greatly obliged for any information you could give me as to what the cause of this difficulty may be and how it can be best remedied.

Denver, Col.

CHAS. JENKINS.

The clutch pedal should be blocked back as shown in Fig. 2, so that it can be easily examined and the work done to good advantage. If dry, the leather should be soaked with castor oil or neat's foot oil, distributed evenly over the surface. Work the clutch pedal back and forth a few times after the oil has been applied and then block it open and leave it in this condition for about a day.

If the clutch is very oily a good grade of fuller's earth with all grit removed may be employed to absorb it.

### Making Preparations for a Long Tour

Editor THE AUTOMOBILE:

[2,765]—I have two Cole model H roadsters, year 1910, 4 x 4 engine. The Cole people state that they have no instruction book covering this type of car and I understand that they have ceased making it. Therefore, I beg to ask of you the following information:

The gears driving the magneto are at the front end of the engine in a case by themselves. This compartment is separated from the crankcase by a felt lining which I can make reasonably tight. Please advise if it is well to fill this compartment full of non-flowing oil or grease or should the regular light cylinder oil be used? There is not much lost motion in these gears, but they make a little noise.

The oiling system of the Cole, as you know, consists of a reservoir in the bottom of the crankcase from which the oil is pumped into two pans. The cranks then take it up. There is a petcock in this pump

# What Other Subscribers Have to Say

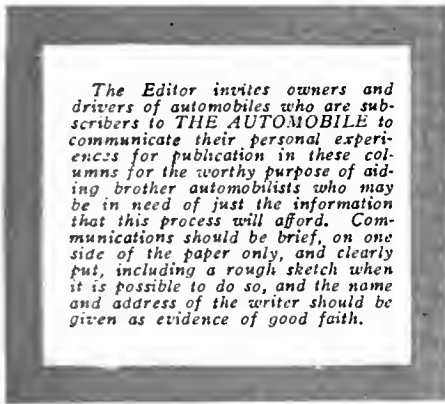

which I do not know the use of. It seems to be placed there for the purpose of determining if the pump is working properly. No oil comes out whether it is turned on or off. It may be possible that when this cock is opened air will be admitted to the pump, thereby lessening the flow of oil. Therefore the petcock may be for the purpose of regulating the amount of oil drawn up from the supply. Kindly advise if this is so.

This car is equipped with a leather-faced cone clutch. Please advise proper treatment and oil to use on this clutch.

The transmission gears are in a casing, oil-tight. They are the usual sliding gear type. This case does not leak oil into the clutch compartment, therefore please advise whether light oil or heavy grease is the best to use.

One of the front wheels has been dished by striking something at high speed. The rim normally is flared outward, but since this accident the entire rim is dished inward. Please advise how this may be repaired.

I am preparing this car for a 1,000-mile tour and would greatly appreciate the information. H. R. VAN DEVENTER.

Sumter, S. C.

The gearcase should be packed with a good quality non-fluid oil. The petcock on the crankcase is for overflow in case the oil level is too high, and the reason that you have not had a flow from the cock is probably owing to the fact that the oil level in the crankcase has not been above normal.

The leather-faced cone clutch should be washed with kerosene and castor or neat's foot oil applied. The transmission is packed in a mixture of oil and grease.

If the wheel is much "out of true" perpendicularly, get a new steering knuckle; if horizontally, the adjustment may be made by taking up on the tie rod. For horizontal adjustment the distance between the two wheels at the front and back should tally; for vertical, jack the car up and spin the wheel. If there is an excessive "wobble," the steering knuckle should be renewed. The best thing to do is to let a competent wheelwright examine the wheel.

## Not Necessary to Tear the Car Apart

Editor THE AUTOMOBILE:

[2,766]—Would it be asking too much of your engineers to solve a problem for me? I have a small Olds runabout, model "R," single cylinder, made in 1903. If you have anyone who is familiar with this type could they tell me how to put a new wrist pin and bushing in the motor without having to tear the whole car down?

Washington, D. C. J. L. HINES.

Remove the body from the car, take off the front end of the crankcase, unfasten the connecting rod from the crankshaft and draw out the piston. The repairs can then be easily made.

## Charging Storage Batteries from Light Circuit

Editor THE AUTOMOBILE:

[2,767]—Will you please give a diagram and instruction for charging storage bat-

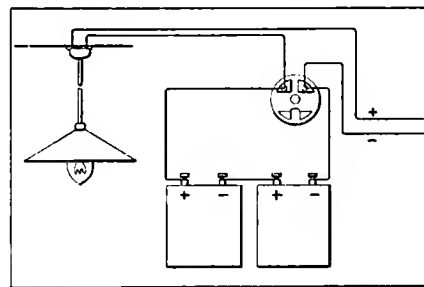

Fig. 3—Wiring diagram showing method of charging storage battery from electric light circuit

teries from an electric-light circuit which is continuous.

T. W. L.

Trenton, N. J.

From the switch that controls the lights run two wires as indicated in Fig. 3. After testing which is positive and which is negative, mark the wires in some suitable manner for future use. In order to carry out this test obtain a weak solution of acid or salt water, and after baring the ends of the wires place them in the solution so that they do not touch and it will be seen that bubbles flow from the negative wire. The wires can then be connected to the battery, but care should be taken that the switch is in the off position.

## Gear Shift Lever Works Loose

Editor THE AUTOMOBILE:

[2,768]—While driving recently and changing speed the gear shift lever of my car became loose on the shaft, and although it was not bad enough to prevent my getting home, nevertheless I do not feel confident in driving the car until I have it

fixed. The shaft is cylindrical and the end of the shaft that passes over the tube is not a very good fit, the two being held together by means of set screws. I should be obliged if you could give me a sketch of a better method of fixing these parts so that my present trouble will not occur again.

ARTHUR T.

Philadelphia.

There is very little advantage gained in having this shaft made of tubing and we suggest that the present shaft be replaced by a solid shaft with the end to which the lever is attached finished off in a square in the manner shown in Fig. 4. If the lever is filed in the manner shown and firmly locked with a bolt and nut you need never fear that the lever will shift or work loose. The shaft will have to be slotted in order to accommodate the bolt, but this will strengthen matters and is another means of preventing rotation.

## Desires French Automobile Literature

Editor THE AUTOMOBILE:

[2,769]—As I am a reader of your paper I take the liberty to ask a few questions. Where or how may I secure some catalogues of the best known French one-cylinder automobiles or some French and English automobile magazines? I would like to get a catalogue of the one-cylinder racing type Mercedes.

C. T. FREDERICK.

Norwalk, Ohio.

The catalogues of the different cars may be had by addressing the manufacturers, who will gladly supply them. The Mercedes car is made in Germany and these people do not manufacture a type such as you describe. An English magazine is the "Autocar," published in Coventry, England, and a French magazine, which may contain the names of the manufacturers desired, is "La Vie Automobile," published in Paris, France.

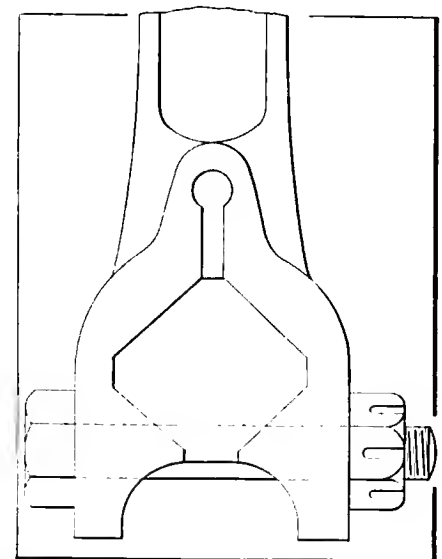

Fig. 4—Method of attaching gear or brake lever so that it will not slip on the shaft

# Meeting Recurring Troubles

## Presenting a Series of the Most Probable Cases

A series of co-related short stories, accompanied by diagrams and characteristic illustrations, indicating the nature of the troubles that are most likely to happen to automobiles, discussing their causes and effects, all for the purpose of arriving at a remedy. It is the aim, for the most part, to show how these troubles may be permanently remedied, and as a secondary enterprise it is indicated how the automobilist can make a temporary repair, thereby enabling him to defer the making of a permanent repair until a convenient time arrives.

**MAGNETO REPAIRING A DIFFICULT UNDERTAKING FOR THE AMATEUR**—For the average automobilist who undertakes to repair his own magneto failure is spelled in large letters just about the time he starts on the undertaking. Aimless tinkering never has repaired a deranged magneto, but it has hopelessly ruined many.

If an ordinary bar magnet is placed on a table the magnetic lines of force are constantly flowing from the north pole of the magnet to the south pole. These lines of magnetic force vary in intensity according to the distance from the magnet, and follow the lines shown in the accompanying illustration (Fig. 1). Electric force is generated when the magnetic flow from pole to pole in the magnet is interrupted, and this is the first principle of the magneto. The ordinary magneto consists of two permanent magnet poles arranged in the form of a horseshoe, the ends of the legs of the horseshoe being the two poles of the magnet. The magnetic current runs between these two poles across the gap which separates them. In this gap is placed the armature as illustrated in Fig. 2, where N is the north pole and S the south pole, the armature coil being wound between the two poles. The armature coil is shown about this core and the ends of the wire terminate in the commutator of the magneto.

If a wire is placed between the two poles of the magnet and rotated as is depicted in Fig. 3, a current of electricity will be induced in the wire which will have a direction of flow directly opposite to the flow of the magnetic current. As the wire rotates the current will start to flow through the wire in the direction shown by the arrows in the cut. When the wire has turned through one-half of a complete revolution the part which was near the north pole of the magnet will now be near the south pole and the current in the wire, since it is opposite always in direction to the magnetic flow, will be reversed. Since this current is reversed on each revolution it stands to reason that there must be some neutral point just before the reversal where there will be no current passing through the coil. This point is at the spot where the coil is horizontal. The flow of the current may be set out diagrammatically as in Fig. 4, the horizontal line being the zero line of no current and the sine curve showing the fluctuations of the current with the change in position of the armature. Three positions of the coil are shown in Figs. 5, 6, 7. These are the positions of maximum current, mean current and no current.

It can be seen that if the core had 2 axes instead of one these current impulses would be more frequent, or, rather, since the windings would be independent, the impulses would overlap each other and give a smoother flow.

The brushes on the armature pick up the current from the coil and carry it to the hind posts of the magneto, whence it is carried by the wiring scheme of the car and distributed to the various points in the system.

**FUEL DIVISION USUALLY TOO COARSE**—In the coarseness of the fuel division lie the chief failures of the typical carbureter. This has been proven again and again by a great many experimenters. Those who have constructed transparent mixing chambers for the observance of nozzle action have invariably found that the fuel left the nozzles as a solid stream or in heavy globules and irregular "chunks," not as a fine spray or mist, as it is supposed to do. Improved design and workmanship on the nozzle or needle valve parts will almost entirely overcome this poor action,

with an increase in power output and fuel economy; but any nozzle form used will give a wet and sloppy discharge with low engine demands, even though a true spray may be delivered with increased demands.

Whatever form is given the nozzle, the effectiveness with which it can break up the fuel varies as the difference between the pressures at its two ends, and, as this pressure difference varies throughout the speed range of the engine, the fineness will also vary. At high-speed engine demands the spray will be better and finer than at low; but this is absolutely necessary, since the time allowance for vaporization is less and the quantity of mixture formed is greater.

The nozzle of average performance will, at medium engine demands, deliver a thin, conical sheet of liquid. This liquid cone is torn away at its edge and carried on by the air column. Some of the fuel torn away is in small enough particles to be considered as spray or mist, and may be taken as contributing directly to the vapor content of the mixture; but the greater part sooner or later strikes some part of the containing walls, from which it is later picked up in the form of globules. These globules are continually picked up and thrown out by the air stream in its progress to the cylinders, until some of them are sufficiently small to become permanently entrained or have been completely vaporized.

Bends in the manifold passages aggravate the expulsion of the liquid globules, but they also permit of fuel once thrown out being readily picked up again. The persistence of rectilinear motion comes into play and throws out the heavier globules at the turns, they being again picked up by a following portion of the air column. This action is repeated at each turn of the mixture lead.

In the foregoing it may seem that the vaporization accomplished by pressure reduction has been placed on a par with that brought about by the heat supply available in the air and passage walls. It is not meant that such an impression be taken. The rate of transfer of heat from the air and walls to the liquid will, of course, be the higher the greater the temperature difference; the lowering of the pressure lowers the temperature of the liquid through partial vaporization, and thus increases the temperature difference. Thus, while vaporization could not go on at a proper rate without such a heat supply, the lowered pressure under which vaporization takes place is an important adjunct, second only to the heat supply.

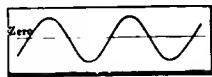

Fig. 4—Diagram showing the fluctuations of an alternating current

ered pressure under which vaporization takes place is an important adjunct, second only to the heat supply.

**DISTINCTION IN VAPORIZATION OF HYDROCARBONS.**—Vaporization due to pressure reduction is distinguished from vaporization caused by the supplying of heat. In the former action vaporization can become only partially complete, however far the process of reduction is carried, since the part of the liquid which vaporizes does so through the abstraction of heat from the remainder, which becomes constantly colder, until finally the temperature of the liquid is so low that vaporization ceases until heat is supplied from some outside source. Where vaporization is brought about entirely by heat from some outside source the degree to which it may be carried depends wholly upon the amount of heat supplied, since the temperature of the liquid is being constantly raised to or maintained at the proper point.

In the carbureting device under consideration neither of the above processes is carried to the

limit, nor goes forward alone and unmodified. They are called into action simultaneously. The reduced pressure due to motor suction causes vaporization with a lowering of the temperature, and the heat of the air tends to cause vaporization through a transfer of heat from itself to the liquid. Thus it appears that each of these vaporizing actions assists the other—the air supplying heat to the liquid as it is cooled by vaporization under reduced pressure, and the reduction in temperature due to pressure reduction facilitating the transfer of heat from the air to the liquid.

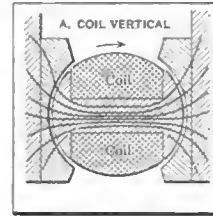

Fig. 5—Magnetic flow with coil vertical. Electrical current at a maximum

Within the temperature and pressure ranges available, the liquid must present, relatively, an enormous surface to the air if vaporization is to be sufficiently rapid. To this end the passage through which the liquid flows is so formed that the liquid is broken up into a spray by the velocity of its effluxion due to the difference between the pressures existing at the two ends of the passage. In any one carbureter the perfection of vaporization is proportioned to the fineness with which the liquid is broken up at the nozzle. The shortness of the time within which vaporization must be completed is what causes the above factor of fineness of division to enter. Since the heat transfer between the air and the liquid, or the passage walls and the liquid, is effected chiefly through the agencies of convection and conduction—the former implying a rapid agitation and relative motion between the particles of the two substances, and the latter the exposure by the liquid of the greatest possible surface areas—it is readily seen that the finer the fuel division at the nozzle the more rapid and complete will be the vaporization and the greater the homogeneity of the final mixture.

**HEATING USUALLY NECESSARY TO VAPORIZE GASOLINE.**—If the nozzle and the conditions under which it operates are such that a true mist-like spray is delivered into the air column, no recourse need be had to air or wall heating devices providing the temperature of the air is 60° F. or higher. But, since such conditions very rarely obtain in practice, the expedient of heated air or jacketed mixing chamber walls must often be resorted to.

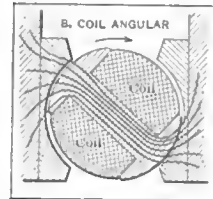

Fig. 6—Magnetic flow with coil oblique. Mean electric potentiality

Because all liquid hydrocarbon fuels are variable and unstable, both in their chemical compositions and physical characteristics, it is very difficult to formulate their actions or determine the best conditions under which to utilize them. Experimental data are placed at an equal disadvantage with mathematical and theoretical analyses in that the exactitude of either method is impaired by the non-uniformity of the substance. However, serviceable figures are entirely within reason; and as such the writer submits the following:

The hydrocarbon known as motor gasoline, specific gravity between .70 and .73, is a mixture of individual substances, each combining carbon (C) and hydrogen (H) in varying proportions. A small percentage of oxygen (O) is often present (never to exceed 3.5 per cent.), but, because of its smallness and sometimes total absence, it will be neglected. The several substances composing gasoline are all of the methane series, the chemical formula for which is expressed  $C_nH_{2n+2}$ . This means that for the entire series, which comprises some eighteen substances, each combines C and H in the proportion of twice as many atoms plus two of H as there are atoms of C.

The first member of the series present in gasoline, pentane,  $C_5H_{12}$ , has a specific gravity of .626; the last member, decane,  $C_{10}H_{22}$ , has a specific gravity of .736. The other members between these two have specific gravities ranging between the two values given and corresponding to their increasing molecular weights. The second member of the series, hexane,  $C_6H_{14}$ , is the representative constituent of gasoline, being present in greater quantities than any of the others. Traces of pentane or the members beyond nonane,  $C_{11}H_{24}$ , specific gravity .723, are seldom found in gasoline. Thus, hexane, though much lighter and more readily vaporized than the several heavier members occurring with it, should be used as the basis for any calculations. This use is justified by the high vapor pressure of hexane, as will be explained later.

**LOSS OF POWER ABOVE 1800 REVOLUTIONS PER MINUTE.**—A motor does not necessarily lose



Fig. 1—Illustrating the flow of the magnetic current through a bar magnet

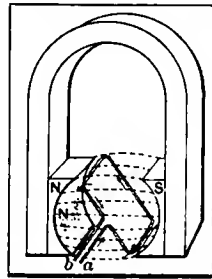

Fig. 3—Showing how the electric current is induced in a magneto coil

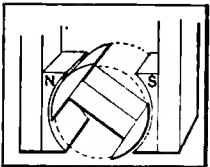

Fig. 2—Position of the armature between the magnets of the magneto, showing direction of rotation



power over 1800 revolutions per minute, as there are several motors that give maximum power at speeds well over 2000 revolutions, and some over 2500 revolutions per minute. The maximum speed of an engine is governed by the setting of the valves and the size of the valve seat and outlet ports; as an example, one of the small cars with a 4-inch bore had three exhaust valves to its one cylinder. On engine speed curves of some motors the falling off of power indicated by the falling line is due to the fact that the speed is too great to allow the charges to be either properly gotten to the cylinders, weakness of mixture, or back pressure of the exhaust. It is supposed that the ignition is correct, although, while it is possible to obtain instruments to fire at, say, 3000 revolutions per minute, some do not give satisfactory results above a certain speed, and this can only be determined by trying out several different makes.

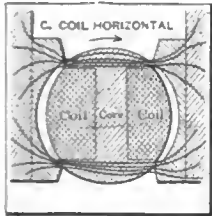

Fig. 7—Magnetic flow with coil horizontal. Zero electric current

**DIFFERENCE BETWEEN 2-CYCLE AND 4-CYCLE ENGINES.**—In the 4-cycle motor there is one power stroke in each four strokes; there are two strokes per revolution of the crankshaft; valves are used to regulate the inflow and exhaust. In the 2-cycle motor there is a power stroke for each two strokes, and ports are so placed as to admit the mixture and permit exhaust on each down stroke of the piston.

**TOOLS FOR REPAIR IN PRIVATE GARAGE.**—To the man who likes to keep his own repair shop as well as to run his own car a well-equipped garage is a necessity. Several of the tools to be found in a garage in which the machines are repaired as well as stored are shown in the accompanying illustrations. A small anvil, while not as generally used as the great usefulness of the tool would seem to indicate, will be found on many occasions to be of great use. The anvil is designed to fill the position of a base plate where any hammering on hard metal is to be done. Besides being a mere foundation plate its shape enables it to be used for a bending slab in cases where it is desired to put either a sharp corner on a piece of metal or to fit a part in place by changing the curvature.

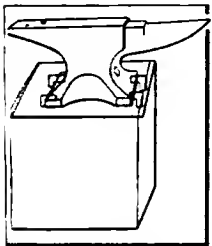

Fig. 8—Usual type of anvil mounted on heavy block and clamped tightly to base to reduce vibration to a minimum

The uses of a vise are so many that it will probably be the first thing that the owner of a machine will find himself in need of if he contemplates doing his own repairing. It is indispensable even for temporary repairs. It would probably be well to have a small and a large vise for different classes of work in a garage that aims to be well equipped for repair work. In connection with the vise a useful part is a pipe bushing which may be inserted when it is desired to thread the pipe or to work it into the desired shape or length. This bushing is fitted with teeth which hold the pipe and do not dent it. The vise can be tilted to any angle at which it is convenient to work, so that when combined with the pipe bushing a very complete and handy tool is given.

A tool which is often used in connection with a vise and connected directly thereto is a drill press. There are two ways in which this tool may be fitted in the repair shop—either by attaching directly to the vise or by having a separate drill press mounted on a base of its own. For the use of a private garage the former is very satisfactory indeed, as it takes up but little room and is large enough for any ordinary use. The part to be drilled is placed in the vise and so adjusted that the drill will strike the desired part of the metal which is being worked. An anvil is often combined with the drill press and the vise and in this way a very useful and compact combination may be had. The larger drill presses may be fed at different speeds, and in this way are adaptable to the metal which is being worked and the thickness of the same. The accompanying illustrations (Figs. 8, 9, 10, 11, 12) show these tools as they are generally arranged.

**REMOVING CARBON FROM CYLINDERS BY USE OF KEROSENE.**—To remove carbon by injection of kerosene in the cylinders is at the best a makeshift method of removing this objectionable foreign matter. A method that has given satisfaction is as follows, if the valves are not placed in the head of the cylinder:

Turn the engine so that the pistons are on a

dead level, and pour through the pet cocks or valve plugs sufficient kerosene to cover the pistons about 1/4 inches and allow it to remain in the cylinder all night. A large quantity by the morning will have found its way past the rings into the base chamber. Now take out the exhaust valves and exhaust manifold and turn the engine several times to allow any remaining kerosene to be expelled; turn the engine so that the piston is in position. If you have no such implement, make or purchase a carbon-removing tool, and through the exhaust valve plug or outlet port, if it is placed conveniently, rake out the carbon, which will be soft. The next operation is most important, and it is upon the care with which this is done that the success of the whole operation depends. It will be understood that the inlet valve has not been touched. Take the inlet valve plug out, and what it was impossible to reach from the exhaust side should be pushed toward the latter. Wash out with kerosene from the inlet plug to the exhaust by means of a syringe, and finally with a mixture of kerosene and gasoline, half and half, clean out with some fresh rag, but always see that the inlet valve of the cylinder that is being worked upon is closed. It is advisable when the pet cock is placed in the head of the cylinder to remove same and pass a wire down it, as the orifice often becomes clogged with carbon, and although the piston and cylinder are clean the carbon in the cock becomes incandescent and causes pre-ignition. It is preferable to pour the kerosene into the cylinder direct rather than to take it in by way of the induction pipe.

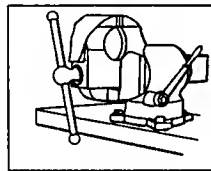

Fig. 9.—Illustrating vise mounted on work bench

As regards the lubricating oil, the base chamber should be emptied and fresh oil inserted before running the engine and it will be advisable to insert a small quantity of lubricating oil in the cylinder as well. This can be done through the valve covers, first allowing the piston to go below half-way down, and by this means pouring the oil on the walls instead of on the piston head.

Inserting a small quantity of kerosene through the pet cocks after every 300 miles should help to keep the engine clean. Some piston heads are turned rough, and will pick up carbon quickly. If this is so in your case, much trouble can be avoided by taking them out and having them polished smooth.

**ALTERING THE COMPRESSION OF A MOTOR.**—When it is desired to increase the compression the most general method is to attach a plate to the head of the piston. This, however, has the distinct disadvantage, especially for a single-cylinder motor, of upsetting the equilibrium. To overcome this it is necessary to touch up the flywheels, which generally carry counterweights. For a four-cylinder motor the inconvenience is less, except in cases where the motor is balanced cylinder by cylinder. There is still the disadvantage of an increase in the weight of the reciprocating parts which is likely to reduce the number of revolutions per minute. A more mechanical method is to machine a special piston with a dome-shaped head. This, however, is a costly procedure. A cheaper method is to make a new and longer connecting rod. If the compression has only to be slightly increased a clever smith can lengthen the connecting rod by heat treatment. This, however, is a delicate operation. Compression can be slightly increased by machining the valve plugs until they penetrate further into the cylinder. The angles should be rounded off in order to prevent pre-ignition, and naturally enough space should be left to allow of the normal lift of the valves. A method often employed is to plane the lower face of the cylinders, or the upper face of the crankcase, thus bringing the head of the piston nearer the top of the cylinder.

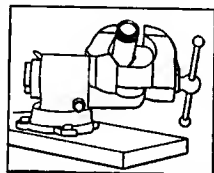

Fig. 10—Showing an ordinary vise with a pipe-holding bushing inserted

Compression may be decreased by the use of dome-shaped valve plugs; by changing the piston for one with an incurved head, or by putting a plate between the bottom of the cylinder and the crankcase. Although compression can be increased by placing a metal plate on the top of the piston, the contrary cannot be done to decrease compression, the piston generally being so thin that any planing of its surface would rob it of necessary strength. It is not advisable to change the connecting rod, for there will be danger of the lower part of the piston touching the top of the crankcase. If the metal is taken off the piston to overcome this the balance of the motor will be destroyed.

**FORESIGHT NECESSARY IN PURCHASING TOOLS.**—It is not very hard to fill the garage and auto-

mobile full of useless tools, yet it is a thing which can be prevented with the use of a little foresight. Taking the matter of wrenches, for instance, a double-ended wrench may be purchased which, if the specifications given to the dealer are correct, will cut in two the number of wrenches carried. It is a very common occurrence to find a machine carrying wrenches, one end of which will fit a bolt located on a part which needs occasional adjusting while there will not be a nut on the car which can be turned by the other end of the wrench. The cut shown herewith (Fig. 13) illustrates a common form of straight wrench with which the average automobilist is no doubt very familiar, since it forms part of the equipment of nearly every car. To set out upon a trip, however short, with an inaccessible nut upon the car is to invite unnecessary delay, but the tool supply should be so designed as to reach everything in reason and yet be as compact and light as possible. It is not desirable to carry an S wrench where a straight wrench or a 15-degree wrench will do the work, as it takes up more room and is no more satisfactory in the way of additional leverage. A very handy thing to have in the garage in connection with the larger wrenches is a short length of pipe which will fit over the wrench. This is only of use, however, where single-ended wrenches are used.



Fig. 13—Illustrating an ordinary form of wrench, generally a part of the equipment of the car

required per hundred miles of travel is not so much that it would more than serve as ballast for the tractor.

**COMPOSITION OF PRODUCER GAS.**—The average gas from anthracite coal has a thermal value of about 135 British thermal units per cubic foot, and the various constituents by volume are: Carbon dioxide, CO<sub>2</sub>, 6 per cent. Carbon monoxide, CO, 24 per cent. Hydrogen, H<sub>2</sub>, 15 per cent. Nitrogen, N<sub>2</sub>, 55 per cent. Also methane, CH<sub>4</sub>, trace. Oxygen, O, trace. Producers may be made in quite compact form and the fuel

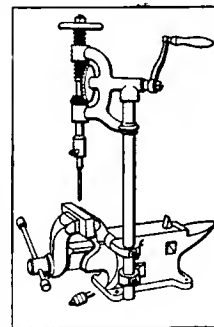

Fig. 11—Drill press, vise and anvil mounted all in one, making a compact set of tools

**THE REAL CARBURATOR.**—The accepted type of carbureter, taken together with its distributing manifold, forms a surface carbureter usually of quite small surface. The manifold walls form the real carbureter, and the device called the carbureter furnishes the fuel to that surface, from which any proper vapor that may exist in the final mixture is carried by the passing mixture of air.

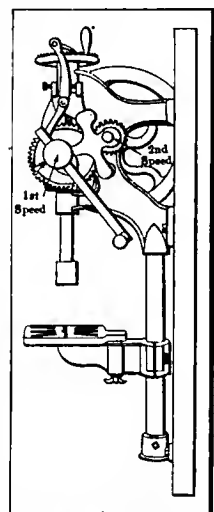

Fig. 12—A large drill press with change-speed gears

By "typical carbureter" is meant a device in which liquid fuel is brought into contact with a moving column of air by the same pressure depression which causes the air to flow, i.e., it is drawn through a passage by the motor suction simultaneously with the influx of the air with which it mixes to form the explosive mixture.

In the "typical" device, fuel is carried by flowing air from the open end of a passage located in a region of pressure lower than that of the atmosphere to which the other end is open. Lowered pressure without a correspondingly lowered temperature tends to cause vaporization. It is undoubtedly true that vaporization starts at this point as soon as the fuel has fairly left the nozzle. The intensity of this action depends upon the extent to which the pressure is lowered. The pressure reduction about the nozzle may be taken at .5 pounds per square inch, which value increases through the manifold to the valves until it reaches a value of 6 to 8 pounds with some six-cylinder engines.



# Short Stories of Current Interest

## Unraveling the Puzzling Situations

*It is pointed out that the greatest puzzle probably lies in the fact that good examples are scarcely ever taken advantage of in a timely way, whereas bad examples seem to have a free pass into everything and go unchallenged until the purchaser no longer indicates a desire to support the issue.*

**I**N the building of automobiles, as in the making of other machines, there are certain practices that are sanctioned by mechanics of experience, and there are certain other practices that have failed to obtain the sanction of authority. Take, for illustration, the use of tapered pins to the exclusion of keys in the joining of rotative members or the members that have to resist torsion; it is not a sanctioned practice, nor can it be, due to the fact that no reliance can be placed upon taper pins under such conditions. In the face of this fact there are designers who harbor the impression that if one taper pin in the absence of a key is a bad thing to use two taper pins should be considered satisfactory. This way of thinking certainly offends logic, and in nine cases out of ten if logic departs the sweet-running qualities of any automobile made in its absence will take wings and migrate to a more agreeable situation. In the meantime there are considerable numbers of automobiles that have their rotative members joined by means of keys with taper pins so placed as to prevent the members from floating away from each other, but even this plan is frequently insecure, due to the fact that the keys loosen up during the course of time and the taper pins are then sheared off, making a nasty mess out of the situation, if nothing worse.

### It Is Extremely Difficult to Understand Why Taper Fits Are Abhorred in Many Quarters

Of the available ways for fastening hubs and other like members on shafts and spindles, taper fits, in the absence of flanges, are the most secure, and parallel fits are not only the hardest to make but they are also the most insecure. The probabilities are that many operators in machine shops are so lacking in skill that a taper fit and the method of its production is beyond their understanding. A little study on the part of those who are unfamiliar with the niceties of taper fits will lead them promptly to the conclusion that there is no more difficulty attached to the machining and grinding of tapers than there is to be encountered in the machining and grinding of parallel surfaces.

If a taper fit is to be made and it is desired to press a hub after it is suitably tapered onto the taper of its mating shaft, the average man balks because he does not understand how to caliper the taper and obtain the desired accuracy. In the meantime, if the taper is made on a basis of 3-16 of one inch to the foot, a little computation will show that a variation of one-thousandth of one inch in the diameter of the taper is equivalent to a movement of 1-16 of one inch of the tapered hub upon the taper of the shaft.

Taper fits are easy to make because the limits of tolerance may be fixed upon a liberal basis, and they are easy to measure because there is a definite relation between any change that may be made in the diameter of the taper and the distance that the members will fetch up on each other due to changing diameter. As an illustration of the limits of tolerance that may be permitted when taper fits are indulged in, it is enough to say that for a two-inch shaft, if a press fit is desired, the limits of

tolerance may be from 0.006 to 0.007 of an inch, and if the taper is finished on a grinding machine the operator who would have difficulty in keeping within these limits of tolerance can scarcely be looked upon as a fit talent to employ in work of this character. It will of course be remembered that the limits of tolerance that can be indulged in under fitting conditions of practice are a variable depending upon the diameter of the taper, and to illustrate this point attention is called to the allowable limits of tolerance if the taper is eight inches in diameter instead of two inches in diameter. In the latter case the limits of tolerance may be from 0.012 to 0.013 of an inch. For other diameters the limits of tolerance are changed in proportion to the taper dimensions.

### Authorities Differ as to Tolerance Limits

In the face of the fact that the questions of tolerance have been discussed for many years, it still remains to be said that no two draftsmen seem to agree with each other, and even among the engineers of quality there is a wide difference in opinion respecting this important matter. One company under the direction of an eminent engineer worked upon this phase of machine building for 30 years, and at the expiration of this time the engineer in question was able to say: "Despite the fact that I have perfected a tabulation of limits of tolerance, taking 30 years to do so, I have never known of any engineer who was willing to risk his reputation by copying the practice that I have thus introduced into the plant over which I preside, and this is in the face of the fact that success has attended my effort." This was not a case involving a desire on the part of this engineer to inflict his ideas upon his brother engineers, but in looking around and observing the performance of machines in general as they come from many plants it was easy enough to see that a large measure of the troubles experienced during the construction period and later in service came from poor fits, and it is conceded by almost every engineer of experience that the great question is to limit the errors that machinists made so that the parts will mate with each other, and the real limit to fix for these errors is founded upon the idea that absolute perfection in the making of parts is an utter impossibility and that "neat" fits must rank as a theory, so that the underlying principle that guides the maker of a machine is based upon "error" and the remaining question is, How much shall the error be?

There are other considerations attending the fixing of the limits of tolerance in the mating of the members that go into an automobile; whether or not the limits are to be plus or minus or plus and minus must be worked out depending upon the influences of the several situations, but the fundamental principle underlying this part of the problem is based upon the "tendency." If, in machining a part, the tendency is to make it undersize the limits of tolerance should be plus; if the tendency is in the direction of an oversize it would then be fair to oppose this tendency by making the limits of tolerance minus. If the facilities are such that the limits of tolerance might be approximated with much certainty, the limits of tolerance may then be on a basis of plus or minus, splitting the limits in half. In the assembling of parts that are not made all in the same plant the limits of tolerance for the parts that have to be made in the plants should be so contrived that they will favorably react in view of the tendencies for error as they are likely to obtain in the parts that are purchased outside.

## Some Facts as to Skidding

*A careful manipulation of the steering wheel can often be made to overcome a very dangerous attempt to skid on the part of either the rear or front wheels. Or the skidding itself can be used to prevent the more dangerous side-slip of the car.*

**E**ITHER the front or rear wheels are liable to slip sideways if the driver attempts to alter the direction of travel suddenly on a greasy road. Rear or driving wheels when driving are more likely to lose their grip on the road than those which are rolling freely. A spinning wheel or one which is locked will often lose its individual direction of travel and become simply a point of contact on the road. From this it will be seen that side slip is usually experienced with the rear wheels and depends on the application of the brakes and the care in driving, and that it need not necessarily result from taking a turn too rapidly or too sharply. This can be shown by driving a car along a greasy road and applying the brakes with sufficient force to lock the rear wheels. The car will immediately tend to turn end-for-end upon the road and even if the road is not greasy a sort of side slipping is set up, which can be corrected by the steering gear, in causing the front of the car to move sideways in unison with or to a greater extent than the rear wheels. If the rear tires cannot obtain any grip on the road, as they are being dragged over its surface the rear of the car is apt to swing around too quickly for the driver to check such a tendency in the brief time available. Side slips of this character can only be checked by either releasing the brakes and thus freeing the wheels or by causing the front wheels to keep the car parallel with the road

as soon as the first signs of slip become apparent, since once the rear of the car has swung around to any extent the driver is powerless to bring it in position again by the manipulation of the steering gear. The wheels need not be actually locked in order to bring this about; all that is needed is for them to lose their grip on the road and this occurs when they revolve at a slower peripheral speed than that of the car or when driven at a higher speed than that at which the car is moving.

**DILUTION ARRESTS COMBUSTION**—Four parts of nitrogen are drawn into the cylinders of an internal combustion motor with each part of oxygen. This nitrogen is not only useless in increasing the effects of the burning, but, on the contrary, it is a positive deterrent, since it dilutes the oxygen to such an extent as to neutralize much of its desirable effect. If the proportion of the nitrogen could be reduced, the burning would be correspondingly more rapid, with the consequent more rapid expansion of the gases formed, which would result in more powerful impulses being delivered to the piston. One method of reducing the proportion of nitrogen is to increase the proportion of oxygen. This has been done many times by mixing certain substances with the gasoline. A substance, to be of value in this connection, should have the following properties: it must contain a fair proportion of available oxygen; it must decompose readily into its constituents; it must be soluble in gasoline; when burned in a closed space it must not leave a liquid or solid residue, and the products formed by burning it must have no injurious action on the metal of which the engine cylinders are made.

# Calendar of Coming Events

## Handy List of Future Competitive and Show Fixtures

### Shows

- Jan. 1-5.....New York City, Grand Central Palace, Annual Show, Automobile Manufacturers' Association of America.
  - Jan. 6-13.....New York City, Madison Square Garden, Twelfth Annual Show, Pleasure Car Division, Automobile Board Trade.
  - Jan. 10-17.....New York City, Madison Square Garden, Annual Show, Motor and Accessories Manufacturers.
  - Jan. 10-17.....New York City, Grand Central Palace, Twelfth Annual Show, National Association of Automobile Manufacturers.
  - Jan. 15-20.....New York City, Madison Square Garden, Twelfth Annual Show, Commercial Division, Automobile Board of Trade.
  - Jan. 27-Feb. 10....Chicago Coliseum, Eleventh Annual Automobile, under the auspices of the National Association of Automobile Manufacturers.
- Race Meets, Runs, Hill-Climbs, Etc**
- Aug. 3-5.....Galveston, Tex., Beach Races, Galveston Automobile Club.
  - Aug. 5.....Scranton, Pa., Track Races.
  - Aug. 7.....Chicago, Ill., Commercial Reliability Run, Chicago Evening American.
  - Aug. 8.....St. Louis, Mo., Reliability Run, St. Louis Automobile Mfrs' & Dealers' Assn.
  - Aug. 12-18.....New Orleans-to-Memphis Good Roads Tour, New Orleans Picayune.
  - Aug. 12.....Baltimore, Md., Track Races.
  - Aug. 12.....Philadelphia, Reliability Run, Quaker City Motor Club.
  - Aug. 12.....Worcester, Mass., Hill Climb, Worcester Automobile Club.
  - Aug. 17.....St. Louis, Mo., Reliability Run, Missouri Automobile Assn.
  - Aug. 25-26.....Elgin, Ill., Stock Chassis Road Race, Chicago Motor Club.
  - Sept. 1.....Oklahoma, Reliability Run, Daily Oklahoman.
  - Sept. 2-4.....Brighton Beach, N. Y., Track Races.
  - Sept. 4.....Denver, Col., Track Races, Denver Motor Club.
  - Sept. 7-8.....Philadelphia, Track Races, Philadelphia Auto Trade Association.
  - Sept. 7-9.....Hamline, Minn., Track Races, Minnesota State Automobile Association.
  - Sept. 7-10.....Buffalo, N. Y., Reliability Run, Automobile Club of Buffalo.
  - Sept. 9.....Augusta, Me., Hill Climb.
  - Sept. 13.....Grand Rapids, Mich., Track Races, Michigan State Auto Association.
  - Sept. 15.....Knoxville, Tenn., Track Races, Appalachian Exposition.

- Sept. 16.....Syracuse, N. Y., Track Races, Automobile Club and Dealers.
- Sept. 18-20.....Chicago, Ill., Commercial Reliability Run, Chicago Motor Club.
- Sept. 23.....Detroit, Mich., Track Races, Michigan State Agricultural Society.
- Sept. ....Brighton Beach, N. Y., Twenty-four-Hour Race.
- Sept. ....Denver, Col., Track Races, Denver Motor Club.
- Sept. ....Detroit, Mich., Reliability Run, Wolverine Automobile Club.
- Sept. ....Steubenville, O., Hill Climb, Automobile Club of Jefferson Co.
- Oct. 3-7.....Danbury, Conn., Track Races, Danbury Agricultural Society.
- Oct. 7.....Philadelphia, Fairmount Park Road Races, Quaker City Motor Club.
- Oct. 9-13.....Chicago, Ill., Thousand-Mile Reliability Run, Chicago Motor Club.
- Oct. 13-14.....Atlanta, Ga., Track Races.
- Oct. 14.....Santa Monica, Cal., Road Race.
- Oct. 16-18.....Harrisburg, Pa., Reliability Run, Motor Club of Harrisburg.
- Nov. 1.....Waco, Tex., Track Races, Waco Auto Club.
- Nov. 2-4.....Philadelphia, Reliability Run, Quaker City Motor Club.
- Nov. 4-6.....Los Angeles-Phoenix Road Race, Maricopa Auto Club.
- Nov. 9.....Phoenix, Ariz., Track Races, Maricopa Automobile Club.
- Nov. 9, 11, 12.....San Antonio, Tex., Track Races, San Antonio Auto Club.
- Nov. 27.....Savannah, Ga.—Vanderbilt Cup Race, Savannah Automobile Club.
- Nov. 30.....Los Angeles, Cal., Track Races, Motordrome.
- Nov. 30.....Savannah, Ga., Grand Prize Race, Savannah Automobile Club.
- Nov. ....Columbia, S. C., Track Races, Automobile Club of Columbia.
- Dec. 25-26.....Los Angeles, Cal., Track Races, Motordrome.
- Date indef.....Port Jefferson, L. I., Hill Climb, Port Jefferson Automobile Club.
- Date indef.....Riverhead, L. I., Road Race, Port Jefferson Automobile Club.

### Foreign Fixtures

- Aug. 6.....Mont Ventoux, France, Hill Climb.
- Sept. 2-11.....Roubaix, France, Agricultural Motor Vehicle Show.
- Sept. 9.....Bologna, Italy, Grand Prix of Italy.
- Sept. 10-20.....Hungarian Small-Car Trials.
- Sept. 16.....Russian Touring Car Competition, St. Petersburg to Sebastopol.
- Sept. 17.....Semmering, Austria, Hill-Climb.
- Sept. 17.....Start of the Annual Trials Under Auspices of *l'Auto*, France.

# THE AUTOMOBILE

Vol. XXV

Thursday, August 3, 1911

No. 5

## THE CLASS JOURNAL COMPANY

E. M. SWETLAND, President

A. B. SWETLAND, General Manager

231-241 West 39th Street, New York City

### EDITORIAL DEPARTMENT

THOS. J. FAY, Managing Editor

GEORGE M. SCHELL, Associate Editor

JAMES R. DOOLITTLE

HUGH P. MacCONNELL

HANS WEYSZ

### ADVERTISING DEPARTMENT

W. I. RALPH, 1085 Old South Bldg., Boston  
 C. H. GURNETT, 910 South Michigan Avenue, Chicago  
 L. G. VOGEL, Avenue, Chicago  
 T. B. VAN ALSTYNE, New York and Phila.  
 H. L. SPOHN, New York

LOUIS R. SMITH, New York  
 FRANK B. BARNETT, 309 Park Building, Cleveland  
 H. H. GILL, 627 Ford Building, Detroit

Cable Address - - - - - Autoland, New York  
 Long Distance Telephone - - - - - 2046 Bryant, New York

### SUBSCRIPTION RATES

United States and Mexico - - - - - One Year, \$3.00  
 Other Countries in Postal Union, including Canada - - - - - One Year, 5.00  
 To Subscribers—Do not send money by ordinary mail. Remit by Draft,  
 Post-Office or Express Money Order, or Register your letter.

### FOREIGN SUBSCRIPTION AGENTS

ENGLAND:—W. H. Smith & Sons, Ltd., 186 Strand, London, W. C., and all book-stalls and agencies in Great Britain; also in Paris at 248 Rue de Rivoli.  
 FRANCE:—L. Baudry de Saunier, offices of "Omnia," 20 Rue Duret, Avenue de la Grande Armee, Paris.  
 GERMANY:—A. Seydel, Mohrenstrasse 9, Berlin.

Entered at New York, N. Y., as second-class matter.

The Automobile is a consolidation of The Automobile (monthly) and the Motor Review (weekly), May, 1902, Dealer and Repairman (monthly), October, 1903, and the Automobile Magazine (monthly), July, 1907.

WRITING of the "state of the art" cannot be undertaken at this time without observing that many of the things that are done automobilewise are too crude to be commended; they must be dragged from their hiding places and cast into the pit of condemnation. In THE AUTOMOBILE for this week are reproductions from photographs showing a defective starting crank and the lacerated hand of the gentleman who undertook to start the motor. It is a queer place to locate knife-blades or the equivalent, which is what it amounts to when the profile of the handle of the starting crank is bounded by sharpened edges, and, remembering that infection of the most virulent sort is likely to be planted upon the handle of a starting crank by some person unawares, it merely remains for the owner of the automobile to have his hand lacerated in the cranking process when he will catch the infection and become a victim of the crude mind that thinks it is building automobiles when in all fairness a true estimate of any such product is not to be described in sanctioned language of any tongue.

\* \* \*

AMONG the improvements that have yet to be made in the building of automobiles, a testing equipment which will locate the inharmonious location of the units to each other is necessary, and few indeed are the automobilists who are in a position to testify to the acumen of designers from this point of view. It is all very well

to design and construct a good motor and to make it pass a dynamometer test before it goes into the chassis, and it is a fine thing to rig up an instrument for determining the abstract capability of the live rear axle, and another device to find such troubles as may reside in the transmission gear. But when these individual tests are conducted to completion and the units so tested are planted in the chassis frame there are a hundred reasons why they may not work in harmony with each other, and, unfortunately, it is the purchaser of the automobile so made who has to cope with the resultant disorders.

\* \* \*

EVERY builder of automobiles will contend that a road test will develop any lack of harmony that may be present in a car after the tested units are assembled and the automobile is sent out upon the road in the hands of the tester. Looking at this situation from another angle makes it possible to point out that the chief engineer and the corps of experts who are so fond of telling what they do are really subordinate to the tester, under such conditions. The chief engineer is only responsible for the design, construction and testing of the individual units, and the "tester" must be given credit for fixing the relations that result in harmony of performance, if by any chance this desirable condition creeps into the aggregation, but if the great designers of the units are willing to admit that the tester measures far short of their capabilities the wonder is that they would be willing to assign to him the task of harmonizing the relations of the units and placing at the disposal of the buyer of the car a silent and flexible performer.

\* \* \*

FURTHER evidence of great activity in the field of motor designing continues to appear in the pages of THE AUTOMOBILE from time to time, and it is almost a moral certainty that the patrons of the industry will become somewhat confused in their ideas if they attempt to choose between these types of motors, or if they serve as the "jury" in the process of arriving at conclusions, rendering a snap-shot decision. Almost every example of piston and slide-valve motors that is now being brought out in the guise of something new and wonderful has been tried in one way or another heretofore, and the only question is, Are the men of to-day so much more skilled in the art that they can gain success in its fullest measure on the very battle ground that brought abject failure to the designers of yesterday? That the art has advanced many measures in the course of a few years is quite too true to merit further discussion, but there are limits beyond which skill in its most refined form, supported by ingenuity in all its ramifications, will fail to penetrate. The patrons of the automobile industry can well afford to lay back in the tonneau seat of a well-made automobile of to-day, listen to the purr of a fine-spun motor, even of the poppet-valve type, and await with equanimity the proof that is now lacking of the newer facts as they bear upon utility, so that when the proper time comes they may compare the products of the several schools of design on a basis of equity and see for themselves which is the best for their needs.

# Special Fire Board Working Hard

## Committee Considering Specifications

*Technical body of the Fire Department is compiling a set of specifications to be followed by the manufacturers of automobiles and fire apparatus in competing for the contract to motorize the New York department. There is \$700,000 available for the purchase of fire equipment at present and much more may be added to that sum. Makeshifts and patch-work are to be at a discount in filling this contract and the whole effort of the department will be directed toward securing the best results.*

**W**ORKING full union hours, the special board named by Fire Commissioner Johnson to motorize the New York fire department is about the busiest committee in the municipal government of New York City. Under the direction of Deputy Commissioner Farley, the board is holding daily sessions at headquarters. Chief Kenlon, of the department, who was named for that position Tuesday noon, Chief John P. Howe and Captain Demarest are the colleagues of the Brooklyn Deputy Commissioner.

Commissioner Johnson is impressed with the idea of improving the service of the department and has instructed the committee to use the utmost diligence in deliberating upon the questions that come before them. He believes that makeshifts are uneconomical and that the perfect fire-fighting apparatus should be a complete whole rather than an assemblage of an automobile and one of the various bodies useful in the work of the department.

In the past sets of specifications for both automobile and fire department bodies have been prepared without plans and drawings and bids have been asked from manufacturers. Some of the apparatus submitted has been good as an automobile and more of it has been good as fire-apparatus, but experience has been plentiful to show that much of the mechanism tested has not proved to be satisfactory as automobile-fire apparatus.

Where specifications have been offered, the bidding has not been sufficiently general to afford the widest choice. The manufacturers of automobiles sometimes have been required to make unusual alterations in their stock models in order to come within the terms of the specifications and, of course, were obliged to rely to a greater or less extent upon the manufacturers of fire apparatus or some of their equipment. The makers of fire apparatus naturally have an advantage in the bidding for bodies, but this is counteracted by the fact that they are not manufacturers of automobiles in a broad sense.

The situation as it has now been developed is that the fire department is looking for apparatus driven by gasoline engines that shall be symmetrical in service, utility and appearance.

It is pointed out that only a small mileage is required of motor fire apparatus in the course of a year. This mileage must be accomplished at high speed and with the utmost certainty. While it is known that wear and tear on an automobile increase as the square of the velocity, the fact remains that fire apparatus has much labor lavished upon it in its periods of rest.

For instance in some of the outlying stations there are few calls in the course of a year, one in a month being a liberal estimate. Now, during all the time except for the few hours or minutes in which the engine is fighting the flames, it stands in its house, the central object of the care and attention of a whole company. Thus it is a simple matter to maintain an

automobile fire engine in the highest notch of efficiency and the fire department in buying such engines does so in the belief that they will last for many years.

The trouble met with in the past has been that numerous makers are able to comply with the measurement requirements and that few of their products have been able to meet the service tests. It is the main object of the board to compile such a set of specifications that when the apparatus is submitted it will cover the ground of the practical tests. Deputy Commissioner Farley has formulated a report covering this point and in the course of a few days it will go to the commissioner for action.

It is the intention of the department to conduct an automobile school for the purpose of training expert drivers and mechanics.

### Garden to House Its Last Show

According to official announcement the automobile show which will be held in Madison Square Garden from January 6 to 20, 1912, will be the last ever to be held in that historic structure. The reason for this state of affairs is not that there will be no more automobile shows of the size reached by recent shows in the Garden, but because the Garden itself is about to be razed to make room for a gigantic office building.

But the show will be held in January and it is predicted by those who will be in charge of it that it will exceed in size and importance anything in the way of an automobile show ever staged in that building.

It will be a two-part show as was that of 1911. The pleasure vehicles will hold forth from January 6 to 13 and the trucks will be on exhibition from January 15 to 20. The same exhibition committee as last year's will be in charge, comprising: Col. George Pope, chairman; Charles C. Clifton, Alfred Reeves and Merle L. Downs, secretary.

The only way the show of 1912 will differ from that of 1911 will be in its contemplated size. Application blanks for space will soon be issued and allotments will be made shortly.

### Whiteside Heads Stevens-Duryea

CHICOPEE FALLS, MASS., July 31—At a meeting of the stockholders of the Stevens-Duryea Company, July 29, W. H.

Whiteside was elected a director of the company. There was also a meeting of the board of directors held, at which Mr. Whiteside was elected president of the company to fill the vacancy caused by the resignation of Irving H. Page. Mr. Page was at the same meeting elected chairman of the board of directors and treasurer of the company.



President W. H. Whiteside of Stevens-Duryea Company

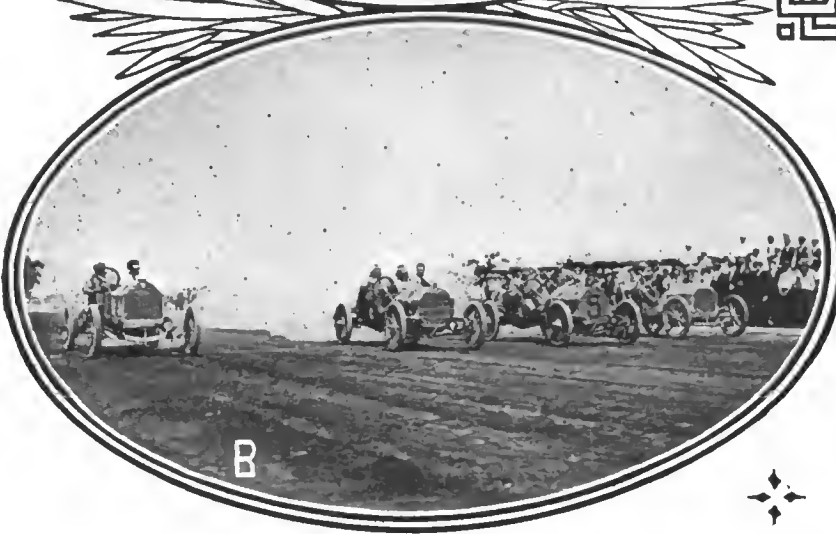
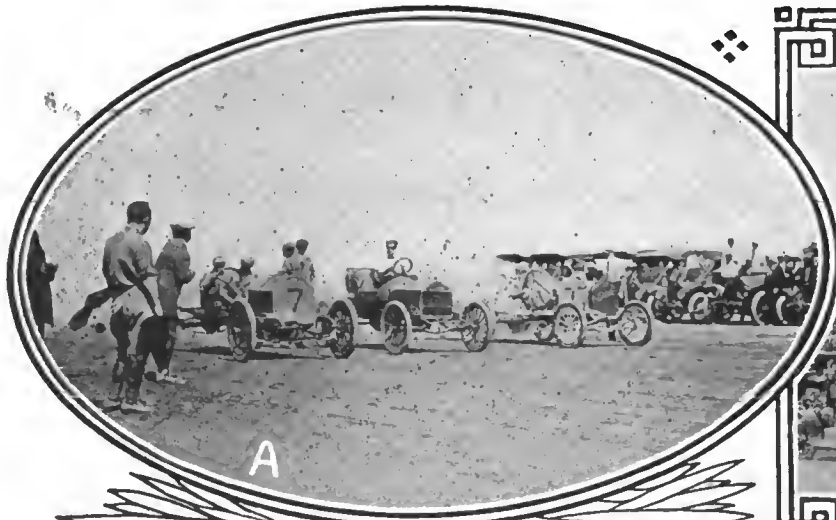

A—Start of the ten-mile 161-230 race—Buick, Metz, Abbott-Detroit  
 B—Line-up in the ten-mile 231-300 race—Kline, a pair of Mercers, Staver-Chicago  
 C—Looking from the field toward the clubhouse during the last race

## Fair Card at Mercer Wins Four

*Remy Brassard changes holders, but remains in same control. Small fields and lack of sharp competition in races are overlooked by big and enthusiastic audience at mid-summer meeting of the Quaker City Motor Club at Point Breeze track. Stock car events find no place on program. Track record is cut about a second in the mile trial. Opel car makes its bow to American public in races.*

PHILADELPHIA, July 29—Approximately 10,000 enthusiasts witnessed the running of the card of races at Point Breeze track this afternoon, the occasion being the annual mid-summer meeting of the Quaker City Motor Club. The Remy Brassard, which was won by the Blitzen Benz (Burman) at Brighton Beach, July 4, was transferred to the Mercedes (Knipper). The ownership of the trophy and prize, however, was not altered, as both cars and both drivers are controlled by the same interests.

The first event of the day was a ten-mile race in which three cars were entered, and developed into a procession soon after the start, a Buick (Brennan) opening a wide gap over its opponents, an Abbott-Detroit, W. P. Padula, driver, and a Metz, piloted by Harry Baker. At the conclusion of the 6th lap the Buick was leading by half a mile, a lead that was further increased as the race progressed, winning in hollow style.

The one-mile exhibition for the Point Breeze circular dirt track record was next carded. After a preliminary tuning-up spin around, Burman signaled that he was ready and the Blitzen Benz completed the circuit in 58 4-5 seconds.

In the second event, after the second mile, the Mercer (Ring-

ler) had all his own way. It, too, was a 10-mile race and drew four entries. During the course of the race the winner lapped both the Staver-Chicago, and Klinekar, which finished second and third respectively. The time made was the best of the day for a ten-mile event, 11 minutes 17 2-5 seconds.

The third race saw the introduction of a freak machine in the shape of a cigar, even to the band encircling it. It was an Opel car, driven by Richter, and had as opponents a Jackson car driven by Harry Cobe and a Klinekar. The last-named car threw a tire on the fifth lap and the race developed into a two-car affair, the foreigner winning in 12 minutes 19 4-5 seconds.

Next run off was a substituted special race between five cars. Right at the jump the Mercer (Hughes) developed engine trouble and was forced to retire from the track. In the meantime Mercer (Ringler) opened up a big lead and the other contestants, Du Closne in a Staver-Chicago, Winkler in a Klinekar and Brennan in a Buick kept plugging away, and the spectators were surprised when Hughes reappeared and essayed the apparently hopeless task of catching up, finishing second.

In the contest for the Remy Grand Brassard and Trophy, Burman and Knipper, the former piloting a 110-horsepower Benz and the latter a Mercedes, cut out a record-breaking pace for the first two miles, at the end of which the Opel (Richter), the only other contender, was trailing half a lap in the rear. The Benz and Mercedes passed the judges' stand almost simultaneously in the second and third laps. Nearing the homestretch on the fourth mile, Burman was seen to slow down and finally stop altogether, his chance gone by reason of a broken feed pipe on the Benz.

The 10-mile handicap was won by the Mercer (Ringler) in





D—Mercer, Ringler driving, winning the ten-mile handicap



E—Line-up of starters in the ten-mile 301-450 race—Kline, Opel and Jackson

F—Start of the 25-mile free-for-all—Mercer, Staver-Chicago, Mercer



# Point Breeze Races With Ease

10 minutes 49 seconds; Mercer (Hughes) finishing a close second in 10 minutes 59 seconds, the other cars finishing at varying distances back, and never seriously threatening the leaders.

The meeting concluded with a 25-mile combination race and had three entrants. Mercer (Hughes), won; Mercer (Ringler), second, and Staver-Chicago (Du Closne), third. The summary:

Division 2C, 10 Miles, 161 to 230 Cubic Inches				
No.	Car.	Driver.	Position.	Time.
22	Buick	J. Brennan	1	12.27
7	Abbott-Detroit	W. P. Padula	2	13.19%
30	Metz	H. Baker	3	13.33%

Time Trial, One-Mile Exhibition for Track Record, 50 2-5			
Car	Driver	Time	Percentage
Blitzen Benz	Burman	58% sec.	

Division 3C, 10 Miles, 231 to 300 Cubic Inches				
No.	Car.	Driver.	Position.	Time.
4	Mercer	Ringler	1	11.17%
21	Staver-Chicago	Du Closne	2	....
11	Klinekar	Morton	3	....

Division 4C, 10 Miles, 301 to 450 Cubic Inches. (Weight limit 1800 pounds)				
No.	Car.	Driver.	Position.	Time.
24	Opel	Richter	1	12.19%
29	Jackson	Cobe	2	....

Class D, Free-For-All, 5 Miles, Flying Start. Remy Grand Brassard and Trophy				
No.	Car.	Driver.	Position.	Time.
3	Mercedes	Knipper	1	5.34%
24	Opel	Richter	2	....
28	Benz	Burman	Withdrew	

Special Race, Ten Miles				
No.	Car.	Driver.	Position.	Time.
4	Mercer	Ringler	1	11.39%
5	Mercer	Hughes	2	11.55
21	Staver-Chicago	J. Du Closne	3	....

Ten-Mile Handicap, Open to All Cars Entered At Meet				
No.	Car.	Driver.	Position.	Time.
4	Mercer	Ringler (30 sec.)	1	10.49
5	Mercer	Hughes (scr.)	2	10.59
22	Buick	J. Brennan	3	....

Twenty-Five Mile Combination Race				
No.	Car.	Driver.	Position.	Time.
5	Mercer	Hughes	1	27.24%
4	Mercer	Ringler	2	.....



Line-up in Event No. 7—Buick, Klinekar, Klinekar, Mercer, Metz, Mercer, Opel, Abbott-Detroit, Jackson

# Big Fields in Elgin Races

## Stock Car Contests Draw Many Entries

*Course for National Stock Championship events has been carefully improved and prepared for the four races that will be held August 25-26. The homestretch has been widened, grades cut down and turns made safe in anticipation of the greatest exhibition of its kind ever held. The average width of the course has been increased at least fifty per cent. over last year and as at present arranged, three cars can move through the stretch on even terms.*

**C**HICAGO, July 31—With twenty-three entries already made in the four big road races that will be run off at Elgin, August 25-26, the prospects are favorable for holding the national stock car championship races under highly improved circumstances.

The course is 8 miles 2,499 feet around and has been prepared for the races with much care. Elgin has spent \$4,000 on the homestretch, which has been widened from 16 feet to 54 feet. Britten's hill has been cut down to a considerable extent and the gravel resulting from the cutting operation has been used in the work on the stretch.

Udina turn at the southwest corner of the circuit has been entirely remodeled. Last year it was a dangerous curve but now it looks as if a car could make it almost at full speed. By cutting into the field on the inside, the road at this point has been widened to 100 feet, an easy swing which gives the drivers plenty of elbow room. The telegraph poles have been moved back from the road and every precaution taken to make the turn safe.

The west leg of the course was a country lane a year ago but now it is one of the best parts of the course. It is a mile in length. The McQueen turn at the northwest corner of the course which will swing the races into the west leg going south also has been improved. Instead of cutting into the bank much the work has been done on the outside.

The east and north legs also are in rare condition. Starting at Hornbeek's the east leg is only a short dash to McLean's corner. At the latter point the owner of the property has given permission for the course to cut across his lawn in order to make a wider turn at that place. This will swing the racers into the backstretch which angles into the northwest and which last year was the best part of the circuit. It has been im-

proved if anything and in many places is wider than before. The foundation of this road is good and it required little work to put it into condition for the race.

As the course is at present it will average 24 feet in width for the entire circuit whereas in 1910 it barely showed 16. The turns have all been given attention and the only one that has not been widened is at Hornbeek's. There the outer edges of the four corners have been so improved that the turn is much safer.

At present the Elginites are engaged in oiling the course. Up to yesterday 24,000 gallons of oil had been put on and there yet remain 50,000 gallons before the work will be completed. Last year only 44,000 gallons of oil were used and yet the course was dustless. Getting such a start this time, the oil will be permanently set before the circuit is turned over for practice.

The work of constructing the grandstand has not started as yet, but this will not delay matters any. The stand this year is to be 650 feet in length and capable of seating 6,600 people. The boxes will be placed at the top of the stand and will be covered.

On the inside of the course at the tape will be located the judges' stand, the press stand, a covered stand for invited guests, the hospital tent and the official cars. The scoreboards will be placed on top of the press stand which is 60 feet in length



Magnificent level straightaway on the backstretch where fast time will be made



The homestretch in front of the grand stand will be 54 feet wide, insuring ample room for three cars abreast

and capable of accommodating 200 newspaper men. In addition to the main score board there will be others placed around the circuit, the farmers having stipulated in their contract with the Elgin association that there be a scoreboard each mile of the course.

The races will start at 11 instead of 10 o'clock. Where the course was closed at 9 o'clock last year, this time the spectators will have until 10:40 to get to their places. Occupants of parking spaces will have until 10:30 to get to their locations.

The honorary referee will be George E. Hunter, of Elgin, representative of the Elgin Watch Company, which gave the Elgin National trophy. The referee will be David Beecroft, president of the Chicago Motor Club. Honorary judges include: R. P. Hopper, Carter H. Harrison, mayor of Chicago; George Tiedeman, mayor of Savannah, Ga.; Harvey Granger, president Savannah Automobile Club; C. H. Hurlburd, president

Elgin Watch Company; W. E. Metzger, president National Association of Automobile Manufacturers; S. A. Miles, general manager National Association of Automobile Manufacturers; Charles Clifton, president Automobile Board of Trade; Carl G. Fisher, president Indianapolis Motor Speedway Company; Asa Candler, president Atlanta Automobile Speedway Company; Hugh Chalmers, Detroit.

The active judges will be: N. H. Van Sicklen, Sr., Chicago Motor Club; Everett C. Brown, president Amateur Athletic Union; T. J. Hyman, Chicago Automobile Club; Allen S. Ray, Chicago Automobile Club; W. Rufus Abbott, president Chicago Athletic Association; Walter Egermann, Aurora Automobile Club; H. B. Hemens, president Elgin Automobile Road Race Association; W. C. Thorne, Chicago Athletic Association; Thomas J. Hay, Chicago Motor Club; Henry Paulman, Chicago Motor Club; James E. Plew, president Aero Club of Illinois;



The turn at Udina, formerly the worst on the course, has been widened to 80 feet

Harold McCormick, vice-president Aero Club of Illinois; J. K. Stewart, Chicago Motor Club; Frank W. Wentworth, Chicago Athletic Association.

In recognition of the generosity of the Aurora Automobile Club in donating the cup for the 161-230 class on the first day it has been decided to call that trophy the Aurora cup instead of the Fox River.

Up to Monday there had been twenty-three nominations made for the four races, the last ones to register being two Simplexes, two Velies, an Abbott-Detroit and a Pope-Hartford. The list to date is as follows:

*Elgin National* (Under 600 inches)—Lozier, two Nationals, three Alcos, two Simplexes, and Pope-Hartford.

*Illinois Cup* (451-600 class)—Two Nationals, two Velies.

*Kane County Cup* (231-300 class)—Three Falcars, three Staver-Chicagos, two Coles, three Colbys and Corbin.

*Aurora Cup* (161-230 class)—Abbott-Detroit.

### Dead Horse Hill Climb August 12

WORCESTER, MASS., July 31—First among the hill climbing contests in the East this year will be the annual event of the Worcester Automobile Club on Dead Horse hill, August 12. Entries are coming in early for the climb and the latest contestants to be enrolled are two Simplex cars which will be handled by a pair of skillful amateur drivers. So far the list is well advanced and the event promises well-balanced fields and keen competition.

The hill is being given a thorough preparation for the climb and the club members believe it will be in better shape this year than ever before. The record for the hill is held by a Stanley Steam Car driven by Baldwin in 1908 and stands at 54 seconds. A Fiat holds the gasoline record in 58 seconds.

The hill is exactly one mile long and is perfectly straight. It starts on the flat and dips slightly immediately after crossing



Showing how Britton's Hill has been cut down. Note the beginning of the oiling process on the right

the line. From the end of the dip it rises sharply in a series of heartbreaking jumps to the summit.

Owing to the fact that this year hill-climbs are rather rare everywhere in the country, the Worcester event is attracting much attention. Last year the meeting was one of the best run off and the program contained a series of stock car contests that developed some interesting climbs.

### Nationals Win at Cincinnati Climb

CINCINNATI, O., July 31—Safe, sane and sensible was the automobile hill climb in this city yesterday afternoon. It was directed by the Cincinnati Automobile Dealers' Association and not a mishap marred the afternoon's sport. The Stanley Hill course was 2,340 feet and had a grade of 11 per cent, and all events had flying starts.

First honors went to the National cars, winning three firsts. The Cino and Ohio, Cincinnati products, gave a splendid account of themselves.

The summary:

Car.	Piston Disp.	Class C. Non-Stock	Driver.	Time.
Empire	153.9		E. Stone	:51 3-5
Flanders	154.8		L. H. Sackett	:58 1-5
<b>Class C. Non-Stock</b>				
Oakland	201.1		A. Bauer	:40 2-5
Elmore	175.9		W. B. Hambly	:48
Paige-Detroit, B	176.7		Wayne Stacy	:49 1-5
E. M. F.	226.2		L. H. Sackett	:51 4-5
Elmore	175.9		A. F. Maiden	:53 2-5
<b>Class C. Non-Stock</b>				
Marmon	299.		Joe Dawson	:28 4-5
Cino	300.7		J. Raimey	:32
Ohio, J.	299.		Chas. Thatcher	:32 3-5
Ohio, J.	299.		H. S. Mathews	:33 1-5
Cino	300.7		F. E. Radina	:36 4-5
<b>Class C. Non-Stock</b>				
National	447.		J. Aitken	:29 1-5
Marmon	318.1		E. Stone	:30
Buick	318.1		H. C. Hisey	:31 2-5
Velie, H-1	334.		R. Jeffkins	:35 2-5
<b>Class C. Non-Stock</b>				
National	589.		H. Wilcox	:25 1-5
Matheson	477.2		H. C. Dixon	:39 2-5
<b>Automobile Club Members Only. (4 Passengers)</b>				
Cino	300.7		F. E. Radina	:38 2-5
National	447.		Chas. Schiar	:40 2-5
Matheson	477.2		J. S. Stevens	:45
American	318.1		L. H. Sackett	:51 1-5
<b>Free-For-All. (4 Passengers)</b>				
Cino	300.7		F. E. Radina	:36 4-5
National	447.		J. Aitken	:39 2-5
American	318.1		L. H. Sackett	:51 4-5
Matheson	477.2		H. C. Dixon	:57
<b>Free-For-All</b>				
National	589.		H. Wilcox	:25 1-5
National	447.		J. Aitken	:28 3-5
Marmon	299.1		Joe Dawson	:29
Marmon	318.1		E. Stone	:29 4-5
Buick	318.1		H. C. Hisey	:29 4-5
Cino	300.7		J. Raimey	:32 2-5
Ohio, J.	299.		H. S. Mathews	:32 3-5
Ohio, J.	299.		C. Thatcher	:33 3-5
Velie, H-1	334.		R. Jeffkins	:36 4-5
Matheson	477.2		H. C. Dixon	:42 3-5

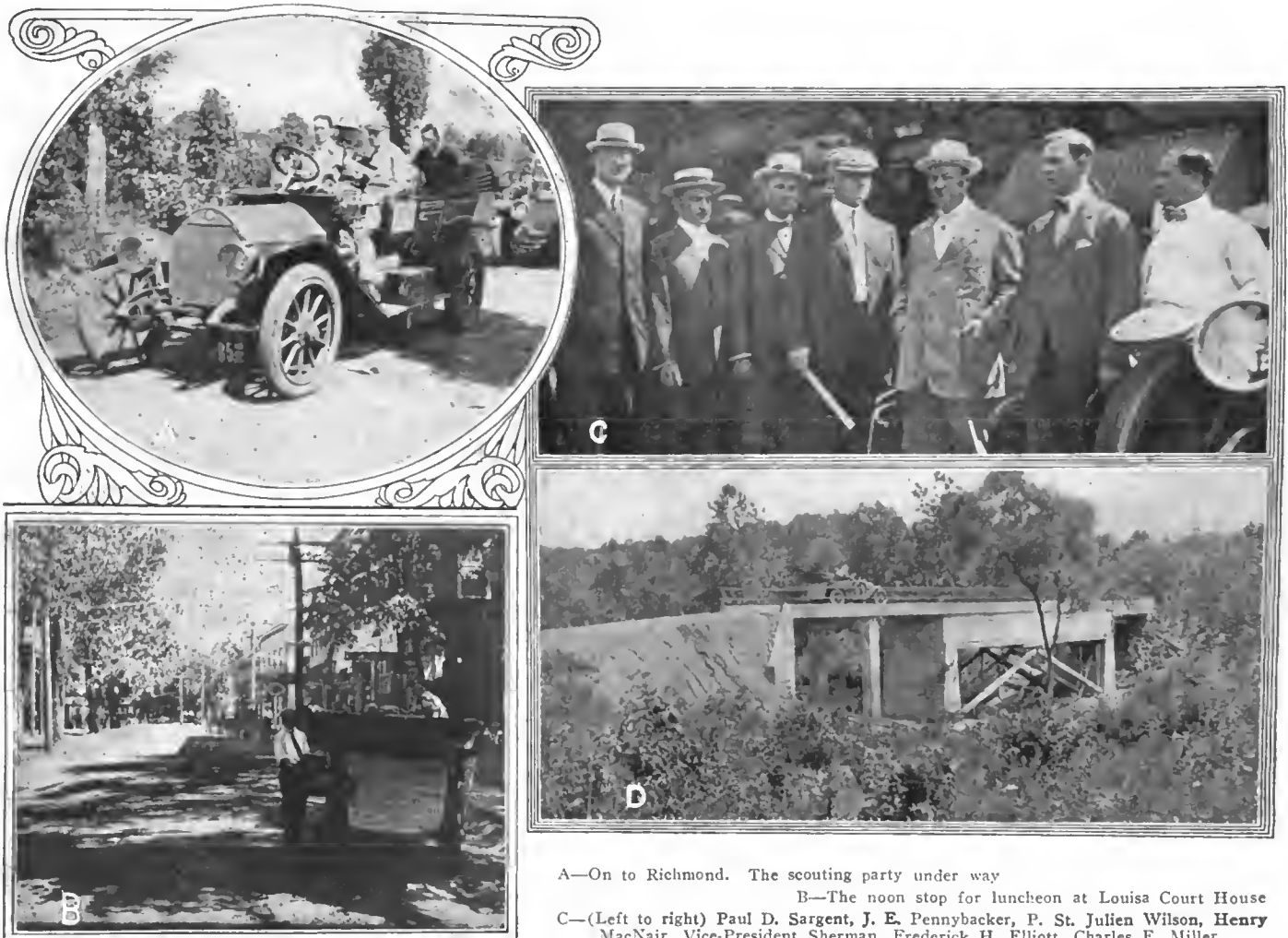

A—On to Richmond. The scouting party under way

B—The noon stop for luncheon at Louisa Court House

C—(Left to right) Paul D. Sargent, J. E. Pennybacker, P. St. Julien Wilson, Henry MacNair, Vice-President Sherman, Frederick H. Elliott, Charles E. Miller

D—Type of new concrete bridge on the Manassas road

## Routing Good Road Tourists

### T. C. A. Selects Path to Richmond

Three cars carrying the pathfinders of the T. C. A. were engaged in the recent trip from Washington to Richmond, where the national convention in the interest of good roads will be held next Fall. The trip is graphically described and the preliminary work for the convention is outlined. Distinguished party accompanies the pathfinders, foreshadowing the great importance of the convention and the interest that it is attracting already.

WASHINGTON, D. C., July 31—Unquestionably, good roads are of first importance from an automobile viewpoint, and when the pathfinders of the Touring Club of America blazed a trail to Richmond last week they started in motion a vast machinery which is destined to result in benefit to the motoring public.

The party which consisted of three cars left the southeastern branch of the Touring Club of America in the Colorado building, at 10.30 a. m. on Monday, Vice-President Sherman being on hand to bid them godspeed. Mr. Sherman is an enthusiastic motorist and the honorary chairman of the advisory board of this branch of the T. C. A. In the first car, a Velie Forty,

Charles E. Miller sat at the wheel with H. E. Duckstein of the *Washington Post*, Howard Fisk of the *Washington Star* and S. S. Grogan of the *Washington Herald*. In the second car, a Packard thirty, Lee A. Folger of the Gordon Motor Company was at the wheel, and Henry MacNair, editor of the *Automobile Blue Book*, sat on the front seat.

In the rear were Hon. Paul D. Sargent, acting director of public roads and Capt. P. St. Julien Wilson, Virginia State highway commissioner. The third car was manned by Fred H. Elliott, secretary Touring Club of America; Harry Ward, automobile editor *Washington Times*, and J. E. Pennybacker, secretary American Association for Highway Improvement.

The middle route was chosen for the trip to Richmond, via Fairfax, Warrenton, Culpeper, Orange and Louisa. While sixty miles longer than the old telegraph road which goes through Fredericksburg, it is very much superior and more easily traversed. The run to Fairfax was made in an hour, where a two-hour stop was made and speeches indulged in. The party also visited the county clerk's office where the original will of George Washington is on exhibition. The party got away from Fairfax shortly after one o'clock and followed the old Middleburg pike, arriving at Warrenton at 4.30, where a funeral interfered with the meeting which was scheduled at that place. The roads





E—Jonah Run, true to its name, gave the travelers trouble  
 F—Plowing ditches with a tractor near Bealeton, Va.  
 G—The road improves as one nears Richmond  
 H—Vice-President Sherman offers congratulations to the pathfinders

up to Warrenton were fairly good although there were a number of water-bars and much bad going along the old turnpike where the driveway had been made to one side of the road.

After being entertained at Warrenton by members of the Fauquier Club, the party started on the road to White Sulphur Springs, passing the magnificent estate of the late E. H. Harriman. A thunderstorm had preceded the party and the roads were very heavy so that poor progress was made.

As the party was nearing Culpeper on the worst part of the roads yet encountered, a horse belonging to E. Lester Jones became slightly frightened and Mr. Jones turned his horse to one side of the road to allow the car to pass. The horse pranced considerably but made no effort to run away. Notwithstanding this, Mr. Jones telephoned to the sheriff to hold the driver of the car until he could come in. A fine of \$25 was imposed for speeding, although all witnesses agreed—including Mr. Jones himself—that it would be impossible to go more than six or eight miles per hour over the road, the speed limit in Virginia being 20 miles on straight roads.

The night was spent at Culpeper and early next morning a start was made via Woodberry Forest School on a fine macadam road into Orange. Here another meeting was called by Commissioner Wilson, and one of the supervisors went with the party to Gordonsville, where they visited a convict camp and watched the process of road construction. The next stop was Louisa where luncheon was served, consisting of Virginia fried chicken with all the attendant delicacies. At three o'clock the journey was resumed, passing through several small villages on the way to Richmond. Twenty miles out the delegation was met by motor enthusiasts of the Southern capital and members of the Richmond Automobile Club who escorted the pathfinding party to the Hotel Jefferson. A representative of the Atlanta

Chamber of Commerce met the party at the hotel, having in view the object of securing the convention for Atlanta next year.

The return trip left the Jefferson Wednesday morning at 11 o'clock, stopping at Louisa for luncheon. The route was retraced as far as Orange, but beyond Orange, instead of going through the grounds of the Woodberry High School, the regular road was followed which had but one turn and over which better time could be made, especially where there are a large number of cars, as the road through the school grounds is very narrow and winding. Culpeper was reached about 6 o'clock and the town was found to be overrun by soldiers of the State militia who were encamped just outside the village.

From Culpeper it was decided to follow the Southern Railroad to Remington. On this stretch about seven miles of macadam was encountered, the only untoward incident being the fording of Jonah Run which was greatly swollen by heavy rains on the night before so that water came up into the carbureter and stopped the pilot car. It was necessary for the occupants to remove their nether garments and push the car out to a point where the carbureter could be drained and again put in action. At Bealeton a road runs directly to Warrenton which is undoubtedly the best way to make the trip and the way which the cars will be routed in October.

However, having in view the exploration of the shorter route the cars proceeded along the route to Calverton, Catlet, Nokesville and Bristol to Manassas, where a number of Union and Confederate veterans were hobnobbing together in commemoration of the fiftieth anniversary of the memorable battle of Bull Run.

From Fairfax the cars went over a new piece of macadam to Vienna and thence into Falls Church, across aqueduct bridge into Washington, which was reached at 4.10 p. m. Thursday.



## Reflections of the French Grand Prix

The latest news to hand from France has it that mechanical troubles put more drivers out of the running than did the tires, as was first thought. The heat was terrific for cars to run the mileage required and no doubt this was responsible in a certain measure for part of the troubles.

ALL credit is due to Hemery on the Fiat for his victory in the French Grand Prix, as the car was a stock car, from external appearances, and in an interview after the race Hemery stated that he and his mechanic had to stop quite frequently to reverse the spring shackles, which were designed to receive the weight of a touring body to hold them down. The outstanding feature of the day was the consistent running of the small Bugatti rated a 7 horsepower with a Monobloc motor of 2 1-2 by 4.3 bore and stroke. The small car held on tenaciously to the last and was only prevented from finishing owing to the fact that the roads were thrown open to traffic at 4 o'clock, there being two other cars still in the running, a Rolland Pilain and a Cote.

The following is the list of cars that were put out of the race and the cause of the trouble: Porthos, cracked cylinder; Cottin, broken steering gear; Rolland Pilain, broken front axle; Corre (Fournier), broken front axle; Cote, broken change speed lever; Cote broken radiator; Excelsior, spark plugs stuck in steel cap; Rolland Pillain, broken front axle; De Dietrich, broken differential; Gabriel, magneto trouble.

The illustrations show the method of banking the turns so that a driver will have a chance of keeping on the road even if he were to take the turn wide.

The car driven by Fournier was four years old, while the Deitrich, driven by Duray, has stood the racket for five years.

In all fourteen cars faced the starter, and when it is remembered that only four were running at the finish, and most of the others had been put out by mechanical troubles, it is an object lesson that manufacturers had better stand down rather than run cars that have not been tested.

## Protests Winner of Wisconsin Tour

MILWAUKEE, Wis., July 31—The protest of the Jonas Automobile Company, Milwaukee, against the awarding of the *Sentinel* and the *Evening Wisconsin* trophies in the second annual Wisconsin reliability tour to any car but No. 1 Cadillac, has been denied by Referee Michael S. Sheridan on the ground that the protest was entered after the expiration of the 24-hour limit after the posting of the official score at the headquarters. The Jonas company has now appealed to the contest committee.

The official score gives the *Sentinel* cup, a sweepstakes, to the Imperial No. 8 and the *Evening Wisconsin* cup, for best score in the roadster class, to the Ford No. 6. The Imperial also wins the *Journal* cup for touring cars.

The protest was based on the allegation that the first examina-



Fig. 1—Hemery in Fiat rounding the turn at the grand stand. The outside banking will be noticed

tion of the Cadillac returned this car with a perfect score, giving it first place in the entire tour. It seems that the technical committee of the W. S. A. A. examined the Cadillac, No. 1, and after completing work on this car released it from the official garage, which was the Auditorium. Immediately other contestants demanded that a Contest Board man be present at the examination and the Cadillac was called back and re-examined when F. E. Edwards arrived in Milwaukee.

The Jonas company claims the Cadillac was marked perfect at the first examination and that the three points imposed when Mr. Edwards arrived might have been due to damage sustained by the car while out of the official garage. In addition the company claims the committee had no right to release the car and then recall it.

## Premier Fleet on Last Stage

RENO, NEV., July 31—Still ten cars strong, the flotilla of Premier automobiles owned and driven by amateurs on a pleasure jaunt across the continent from Atlantic City, N. J., to San Francisco and Los Angeles, is on the home stretch. The party will essay the climb of the Sierra Nevada mountains, probably in the vicinity of Truckee, the intention being to proceed to San Francisco by the northern route.

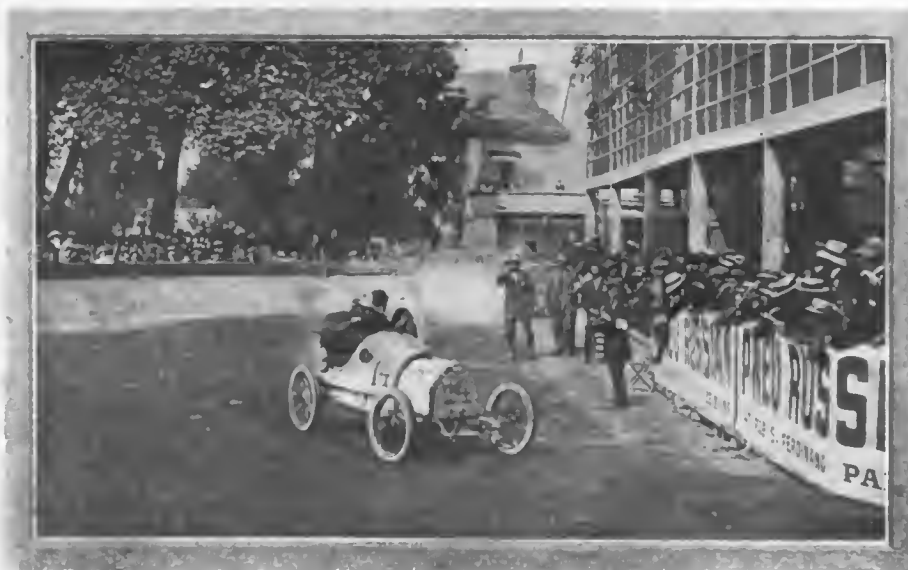

Fig. 2—The 7-horsepower Bugatti receiving the plaudits of the spectators for the fine performance it put up

### Diller, Neb., Helps Form Club

OMAHA, July 31—The southern counties in Nebraska are especially interested in good roads and in automobile clubs. D. E. Watkins, secretary of the Nebraska Automobile Club, made a tour through these counties, last week, organizing automobile clubs. The little town of Diller, whose five hundred inhabitants have stirred up such an interest in good roads in southern Nebraska, still has the same keen spirit. A meeting was held at Fairbury, Monday night, and fifteen automobiles drove the fifteen miles to Fairbury from Diller. There was a large attendance at the meeting, and the club was formed with fifty-one charter members. The following officers were elected: J. W. McDonnell, Fairbury, president; L. M. Nelson, Fairbury, vice-president; W. M. Lewis, Fairbury, secretary and treasurer. A

## Minnesota Winners: Marmon; Flanders

*With clean ~~run~~ scores after a grueling drive across the mountains to Helena, the Marmon touring car and two Flanders runabouts were awarded the honors in the registered classes in the annual tour of the Minnesota State A. A. All the contestants in the unregistered division were given clean scores. The affair proved to be an unqualified success.*

HELENA, MONT., July 29—According to the announcement of Referee Dutton to-day, the Marmon driven by B. Fawkes, and two of the three Flanders, Nos. 12 and 14, were clean in the regular competition in the Minneapolis-Helena automobile run that has ended here, after a tour of nine days.

The Minneapolis Journal trophy was awarded to the Marmon in the Touring car class, while No. 12 Flanders was given the Phillips trophy in the runabout class, with the Gregg trophy going to the No. 14 Flanders as second prize. The Colby, which had 5 points against it, was given the Warner trophy as second prize in the touring car class.

It still is undecided which of the four cars will get the special Minnesota State Automobile Association trophy which was put up for competition among the cars which had not been registered as stock with the Contest Board. All four of these—a Pierce-Arrow, a Packard and two Kisselcars—are eligible, for each had a perfect score.

The contest was run under grade 3 of the A. A. A. rules, penalizations being only for work and time and with no technical examinations at the end of the run. Had there been one it almost is certain none of the cars that participated would have been perfect.

The tour was unique in that it was accompanied by a special train on the Great Northern Railroad, furnished by President Louis Hill, which was used by the tourists for a hotel, meals being eaten aboard by the motor travelers. Another feature of the run was the good roads angle. A prize, the Hill trophy, was offered the Montana county having the best roads. By vote of contestants this was given to Lewis and Clark county.



Fig. 3—Maurice Fournier, snapped a few minutes before his fatal accident, due to the breaking of the front axle

director was elected from each township in the county to oversee the roads of that township.

### Syracuse Club Host to Orphans

SYRACUSE, N. Y., July 31—One hundred and seventy-eight of the children of The Onondaga Orphans' Home were guests of the Automobile Club of Syracuse, Thursday of last week, on a motor car ride about the city and to the Onondaga Indian Reservation, concluding with an outing on the farm of Edward I. Rice, at Dorwin Springs.

Fifty cars were loaned by members of the club, and there were several cars sent in excess of the demand.

All but a dozen children enjoyed the outing. These youngsters, who were suffering from whooping cough, were promised a joy ride of their own as soon as they shall have recovered.

### Barnes to Sell Steel Castings

Claire L. Barnes & Company has completed arrangements whereby it becomes direct factory representative, selling the entire output of the Fort Pitt Steel Casting Co., McKeesport, Pa., makers of small steel castings exclusively, from a direct steel process.



Fig. 4—General view at the start, incidentally showing one of the bad turns and the bandful of spectators

Four of the cars in the tour, accompanied by one from Helena, continued from here to Glacier National Park, 250 miles farther in the heart of the Rockies, as guests of Louis Hill, president of the Great Northern. A run will be made by motor to Kalispell, a 2-day trip, then follows a 3-day journey on horses through the park. The cars in this trip are the Britson Pierce-Arrow, which acted as press car on the tour; C. P. Merwin's Corbin, the pacemaker; Louis Hill's Packard and Walter Berkey's Packard. The party is accompanied by the special train. The summary:

No.	Car and driver.	1st day	2nd day	3rd day	4th day	5th day	6th day	7th day	8th day	9th day	Total
1	Maxwell, O. W. Klose.....	0	0	0	121	0	0	0	21	0	142
2	Marmon, B. Fawkes.....	0	0	0	0	0	0	0	0	0	0
3	Amplex, R. P. Wiseman.....	0	0	0	6	14	3	Withdrawn			0
4	Halladay, O. A. Palmund...	0	0	0	36	8	0	0	0	0	44
*5	Kisselkar, C. L. Bonwell...	0	0	0	0	0	0	0	0	0	0
*6	Kisselkar, C. Rice.....	0	0	0	0	0	0	0	0	0	0
*7	Pierce-Arrow, J. Suckow....	0	0	0	0	0	0	0	0	0	0
8	Hupmobile, E. B. Stimson..	0	0	0	0	0	0	7	3	0	10
9	Abbott-Detroit, A. N. Smith..	0	0	0	0	0	6	0	0	0	6
10	Stoddard-Dayton, J. H. Prior	0	0	0	180	15	0	0	0	0	195
11	Colby, M. G. Armstrong....	0	0	2	0	3	0	0	0	0	5
12	Flanders, B. M. Scott.....	0	0	0	0	0	0	0	0	0	0
13	Flanders, F. A. Witt.....	0	0	0	0	0	0	Withdrawn			0
14	Flanders, G. Herron.....	0	0	0	0	0	0	0	0	0	0
15	Krit, J. E. Dougherty.....	0	12	38	0	996	0	0	0	0	1046
16	Petrel, A. L. McNurlen....	0	0	3	12	83	12	6	0	0	116
17	Cole, B. T. Hoyt.....	0	0	5	0	0	0	3	0	0	8
18	Cole, W. L. Rose.....	0	0	0	461	0	0	0	0	0	461
*19	Packard, W. Stork.....	0	0	0	0	0	0	0	0	0	0

\* Non-registered class.

### Franklin Workers Enjoy Picnic

SYRACUSE, N. Y. July 31—The employees of The H. H. Franklin Manufacturing Company held their annual picnic at Long Branch to-day, 4,000 persons being present. The resort is a few miles from Syracuse and reached by trolley. A feature was a concert given by a band of twenty pieces. There were various athletic events. It was the largest-attended picnic the Franklin forces have ever held.

### Locomobile Fire Wagon for White Plains

While the tendency to displace horse-drawn fire apparatus by motor-driven vehicles is very pronounced in the large cities of the land it is even stronger in the suburban localities and in the smaller cities.

The following towns near New York have contracted for motor fire apparatus, some of which is being delivered now and some of which has been installed: Passaic, Paterson, Newark, Bronxville, Irvington and White Plains. In the latter place a Locomobile combination chemical and hose wagon has just been delivered.

The new wagon is rated as 40-horsepower, four cylinders, 5 by 6 inches. Ten men can ride on it and there is room for 1,000 feet of hose and two chemical tanks with ladders and other equipment.

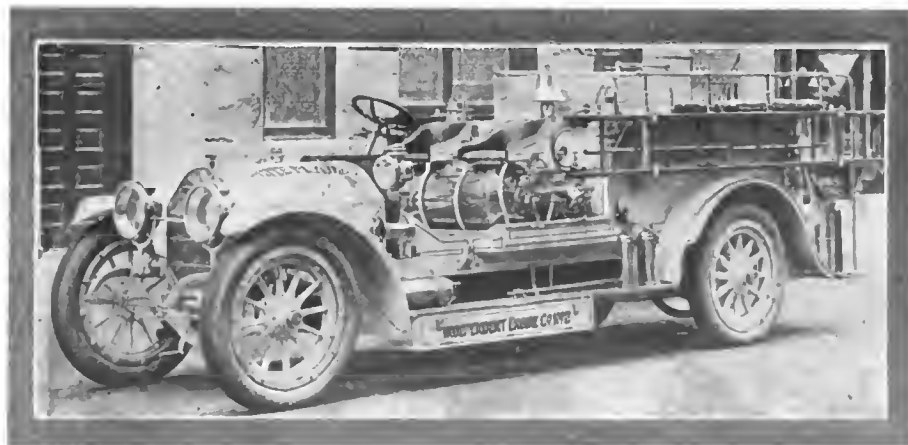

Locomobile combination fire wagon in service at White Plains, which was recently delivered to that town

### U. M. Parts From Component Companies

The dissolution of business relations of the United Manufacturers as a sales organization with four of its chief elements has been officially announced, following a series of conferences, the last of which took place Tuesday, Aug. 1.

The full text of the announcement is as follows:

"The United Manufacturers, as a sales organization, has discontinued the sale of the products of—

"Weed Chain Tire Grip Co., Bridgeport, Conn.

"The Jones Speedometer, New Rochelle, N. Y.

"N. Y. & N. J. Lubricant Co., 165 B'way, New York City.

"C. A. Metzger, Inc., 239 W. 56th Street, New York City.

"The desire to avoid the appearance of a combination in restraint of trade is the purpose of this step.

"The above manufacturers will continue the distribution of their products through the former branch offices of the United Manufacturers, in charge of their branch managers.

"UNITED MANUFACTURERS,

"G. C. Holmes, Treasurer."

### Jersey Trade Seeks Open Door

NEWARK, N. J., Aug. 3—The New Jersey Automobile Trade Association, which has hitherto held itself aloof from the wrangles incidental to the administration of the present New Jersey automobile law, has come out squarely against the policy of J. B. R. Smith, Commissioner of Motor Vehicles, and in a series of resolutions, requested him to recede from a position which the association believes is inimical not only to the best interests of automobilng, but of the State of New Jersey at large. The resolutions which were unanimously passed at a meeting of the Trade Association held a few days ago, are as follows:

"Resolved, That in view of the fact that New York State has for all past years since automobiling began (this present year excepted) permitted all residents of New Jersey to enter and use her hundreds of miles of improved roads with the same freedom as her own citizens, provided only that they were duly registered in their own State, notwithstanding that New Jersey has compelled her (New York's) residents to submit to many indignities and to pay a tax; and the further fact that New York stands ready now to grant the free use of her roads to citizens of New Jersey should New Jersey grant her citizens the same privileges, it is the unanimous opinion of the New Jersey Automobile Trade Association that the action of the Commissioner of Motor Vehicles, J. B. R. Smith, in withdrawing from residents of New York the slight privilege which our State law concedes them now, shows a feeling of resentment which one State of the Union should not show to another, and is, in our opinion, very bad judgment; and it is further

"Resolved, That the general principle of serving notice on residents of New York, Pennsylvania and Delaware in effect that they are not welcome to our State is going to do the manufacturing, hotel, real estate and all other business interests of New Jersey untold injury which will take years to make up for, in addition to giving our State a reputation for narrowness of which she is not deserving.

"It is further resolved, That a set of these resolutions be forwarded to Commissioner J. B. R. Smith with the request that he immediately reconsider his action."

The New Jersey Automobile Trade Association, which is composed of the leading dealers of the State, stands committed to the policy set forth, and it is understood, will wage a vigorous campaign for the re-establishment of the eight-day touring privileges to non-resident motorists such as the New Jersey law provides, but which Commissioner Smith has abrogated in the case of certain States.

### Heads Croxton Sales Dept.

Geo. S. Patterson, formerly branch manager of the Thomas B. Jefferies Company, and later with The White Company, has been elected general sales manager of the new Croxton Motor Company, of Cleveland, Ohio, and will take full charge of the sales of this company which will manufacture taxicabs, pleasure cars and trucks.

### Glidden to Be Good Roads Tour

Owing to the lack of sufficient entries the postponed Glidden tour of 1911 has been abandoned and in its place the tour of 1911 will take place in October and be run over the route of the National Highway, extending from New York to Jacksonville via Atlanta.

Returning to the original idea of the donor of the trophy, the tour, appealing particularly to owners, will be conducted under regulations demanding reliability and regularity, without reference to rigid technical restrictions.

From the Atlanta Chamber of Commerce and the Jacksonville Board of Trade came representatives who were prepared to negotiate a definite proposition. Atlanta was represented by Edwin P. Ansley and Major John S. Cohen. H. B. Race spoke for Jacksonville.

The 1911 Tour will be conducted under Grade IV of the A. A. A. Reliability Rules, with practicable daily running schedules, possible of accomplishment by any tourist.

The cars will be stamped in their essential parts, there will be no observers and the only penalty assessed will be for lateness at controls. A nominal entry fee of \$25 will be charged and present indications point to a large entry list of individual owners.

A \$200 cash prize will be offered for the best performance in each of the seven price divisions.

Any owner of a stock car shall be eligible to enter.

Entry blanks and full conditions will be issued immediately.

### Saurer Truck Reaches New York

Marked with travel stains but otherwise apparently in good shape the transcontinental Saurer truck came to an end of its long journey Wednesday afternoon in New York.

The truck was run down to the City Hall and then up Fifth avenue and came to rest at its garage on Fifty-fifth street. The Motor Truck Club acted as escort for the big car. The car left Denver for New York via San Francisco on March 1 carrying a load of three tons and worked its way across the continental divide and up the Pacific coast. Thence it started eastward and climbed the mountains; forded the rivers and crossed the deserts to the Mississippi valley, completing the last 1,000 miles by easy stages.

### Senator Company Ready to Start

PITTSBURGH, July 31—The Senator Motor Car Company, capital \$200,000, has completed its organization as follows: President, C. E. Vance, of the Consolidated Manufacturing Company and the Anchor Packing Company, of Philadelphia; treasurer, P. T. Coburn, who was formerly advertising manager of the Westinghouse Electric & Manufacturing Company, of Pittsburgh; secretary and manager, A. F. Schmidt, formerly with the Penn Motor Car Company, of Pittsburgh. The directors are John F. Edmunds, of the Anchor Packing Company, of Philadelphia; Dr. E. R. Walters, head of the Department of Health, of Pittsburgh, and G. C. Campbell, of Pittsburgh.

The company has established offices in the Jenkins Arcade Building on Liberty avenue. It is going to locate on Pennsylvania avenue, North Side, and is fitting up two buildings 80 x 400 and 300 x 400 for its use. It will manufacture four distinct types of cars; a two-seated roadster of 40 horsepower to sell for \$1,250

and up; a light delivery truck of 35 horsepower capacity, 1,500 pounds, to sell for \$1,000; a heavy delivery truck, capacity three to five tons and of 60 horsepower; a four-seated touring car to sell for \$1,800. The roadster will have a 116-inch wheelbase and a 34-inch wheel with 4-inch tires. It will have a straight line drive, low center of gravity, thus distributing the vibration between the axles. A feature of the car will be the straight pulls on the brakes. The company expects to build 1,000 of these roadsters next year.

### New "Six" Makes Its Début

MILWAUKEE, July 31—Carl Lipman, president of the Lipman Manufacturing Co., Beloit, Wis., centrifugal pumps, etc., has brought out a six-cylinder touring car built according to his own specifications and for the most part in his own shops. It is highly probable that Mr. Lipman will organize a company to manufacture the car at Beloit. The six cylinders are cast in pairs and a feature of their construction is the fact that the cylinder dome is removable, to permit of ready access to the combustion chamber and the valve mechanism in order to make inspection easy.

Ignition is by high-tension magneto, cooling by a Lipman centrifugal pump, and the car is supplied with a self-starting device of Mr. Lipman's own invention. The car is fitted with annular bearings throughout. It weighs about 2,400 pounds as put up by Lipman with a toy tonneau, 122-inch wheelbase and 36-inch wheels.

### Weed Chain Patent Upheld

CHICAGO, July 27—By decision of the Circuit Court of Appeals in the northern district of Illinois, what is familiarly known as the Parsons patent covering the right to manufacture anti-skid chains for motor car wheels was to-day upheld and the decision of this court made in January, 1911, reversed. The decision was reached by Judges Grosscup, Baker and Kohlsaat, circuit judges, and is the finding in the case of Patent Excelsior or Supply Co. and Motor Appliances Co. vs. Weed Chain Tire Grip Co., Harry D. Weed and Parsons Non-Skid Company, Limited.

### General Motors Truck Company

LANSING, MICH., July 31—The General Motors Company, of which the Olds Motor Works is a constituent part, has announced the formation of a selling and service company, under the name of General Motors Truck Company, to market its entire product of commercial cars. The formation of the separate company has been effected to concentrate the efforts of the manufacturing and the selling ends of the business on their respective lines:

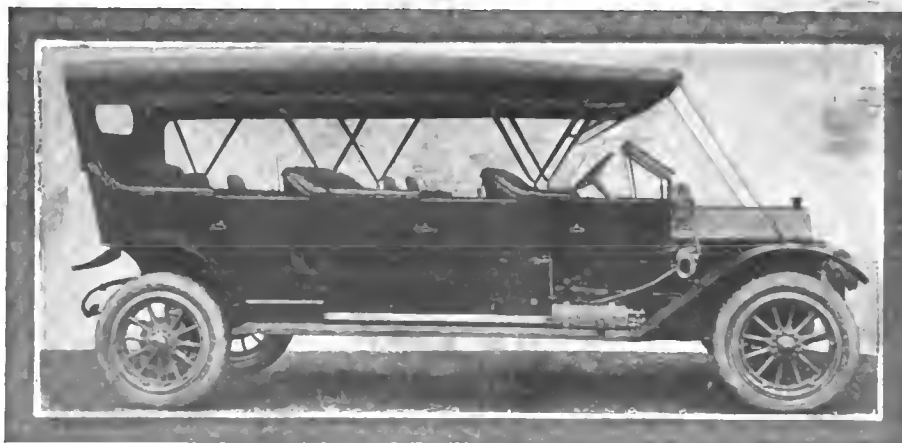

Twelve-passenger torpedo recently shipped by Atlas Motor Car Company for summer resort work



## Seen in the Show Window

**E**XTRA seats which fold out of the way when not in use certainly make for comfort, except when they invite some indiscreet acquaintance to force his personality upon the polite owner of the car; but this is only the exception proving the rule, and if the automobilist desires to equip his machine with extra seats, it will be the course of economy to get high-class goods, even though they may be a little high priced. Quality is the principal claim made for the patent Luxury folding seats (BI), the framework of which is made of drop-forged steel, making possible a rugged and compact construction, while artistic design and finish furnish the good looks. These seats are the product of the Graves & Congdon Company, Amesbury, Mass.

**R**EMEMBERING that the cooling water as it flows from the radiator to the engine cylinder jackets is moved through the office of a pump, and that this latter puts the water under pressure, it is easily understood that all water hose must be absolutely waterproof, and connections very tight lest some water be lost. This would not only result in the water being spilled all over the power plant, but the motor not being cooled to a sufficient measure would be damaged by the process. To avoid leaky connections hose is generally pressed against a pipe with some wire, but besides the fact that this is not a reliable method, the hose will suffer and in time will be cut by the wire. A pump connection using a similar principle in a refined sort of way is seen at (BJ), it being the Nielsen's. It is attached by pulling back the ring pressed by a spring against its seat which is cut into six sections. Thereafter the end of the hose is slipped over these sections and held in place and the ring pushed into place by the pressure of the spring. The Auto Equipment Manufacturing Company, of 18 Pearl street, Newton, Mass., market this device.

**S**TORAGE batteries, so widely used for lighting automobiles and igniting the gasoline-air mixture, differ principally on account of the method of how the active material is placed in the plates, a good construction resulting in an increase of efficiency rather than one of capacity per weight unit. At the same time, a high efficiency is indicative of a relatively long battery life, proving that one virtue is always in another virtue's company. The illustration (BK) shows the Bison Sparker, a battery comprising three six-volt cells which will last through 40 ampere-hours, and the advantages mentioned above are claimed to be present in this make of battery. At all events, the illustration gives an idea of the

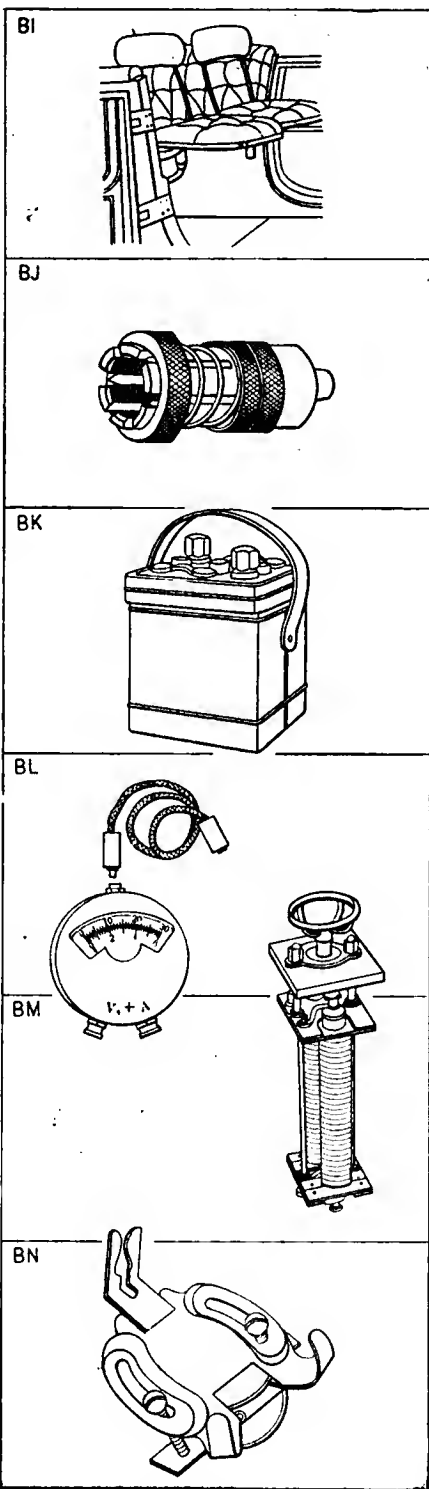

BI—Luxury folding seats are comfortable and elegant  
 BJ—The Nielsen connection holds hose in tight relation  
 BK—Ignition type of the Bison-Sparker storage battery  
 BL—The Rear-Rite voltmeter is made in pocket size  
 BM—Rheostat for lowering the voltage of battery-charging circuit  
 BN—Sterling time clutch for holding watch to steering wheel

compact and strong construction of the battery which is made by the Bison Storage Battery Company, of 38 Riley street, Buffalo, N. Y.

**M**EASUREMENTS are now made compact and precise, owing to the vast experience of the manufacturers of the meters and instruments used for the purpose, and while the first of these products necessarily had to be of medium size, since it then was not possible to combine the features of miniature and precision, capable instruments are now manufactured, these being of sufficiently small size to be carried in one's vest pocket. In Fig. (BL) we illustrate the Read-Rite, which is a voltmeter and made by the Read-Rite Meter Works at 18 Main street, Buffalo, N. Y. The plug connecting the meter with the electric line to be tested can be taken out of its socket and kept separately.

**E**LECTRIC accumulators cannot be charged directly from a high-tension main since too high a voltage would do damage to the cells. It is for this reason that some kind of resistance must be used and placed in the circuit to reduce the voltage, and of these resistances, lamps are the most popular, though not the handiest. A small and effective resistance is the battery-charging rheostat illustrated at (BM) containing no wires or grid which might be burned out by the process of charging, and it may be mounted either on a wall or switchboard. The working parts being well insulated are not affected by moisture which therefore does not disturb the successful operation of the rheostat. It is sold by Howard M. Eldred, of 818 Pabst Building, Milwaukee, Wis.

**E**VERY automobilist will admit that he likes to have the time before him when driving, but not every one will indulge in the expense of buying a specially constructed timepiece to be permanently attached to the car. Automobile operators will be interested in the realization of a very practical scheme by which it is possible to attach one's watch instantly and safely to the steering wheel of the car, without fear that it will be thrown off by the movements of the machine. The winding post of the watch slips into the notch of the time clutch (BN), and the whole thing is supported by the two bent-up pieces of metal. The clutch is screwed on to a nave of the steering wheel; it is furnished in nickel, polished brass or gun metal finish by its makers, the Sterling Manufacturing Company, Inc., Staunton, Va.



# THE AUTOMOBILE

## Grade Crossings a Prime Nuisance

### Take 87 Lives in About Ten Weeks' Time

*Besides being uneconomic from the viewpoint of railroad operation, grade crossings have proved themselves to be a fearsome danger to all kinds of traffic, particularly automobiling. The daily press recounts a fatality or more nearly every day, all of which are sinfully unnecessary. By delaying traffic the grade crossings take something from the pleasure of riding in an automobile or carriage, and consequently put a damper on realty values in the sections affected.*

the same period there were eighty-seven persons riding in automobiles and carriages who were slaughtered by railway trains at grade crossings. They were not criminals and presumably, at least, did not deserve their fate and yet, nevertheless, they are just as dead as the murderers who were hanged or shocked to death.

As a matter of fact, the victims of the grade crossings were very largely persons of culture, refinement and wealth, and to a notable degree represented the best elements in society. They met death in New York, Pennsylvania, New Jersey and a dozen

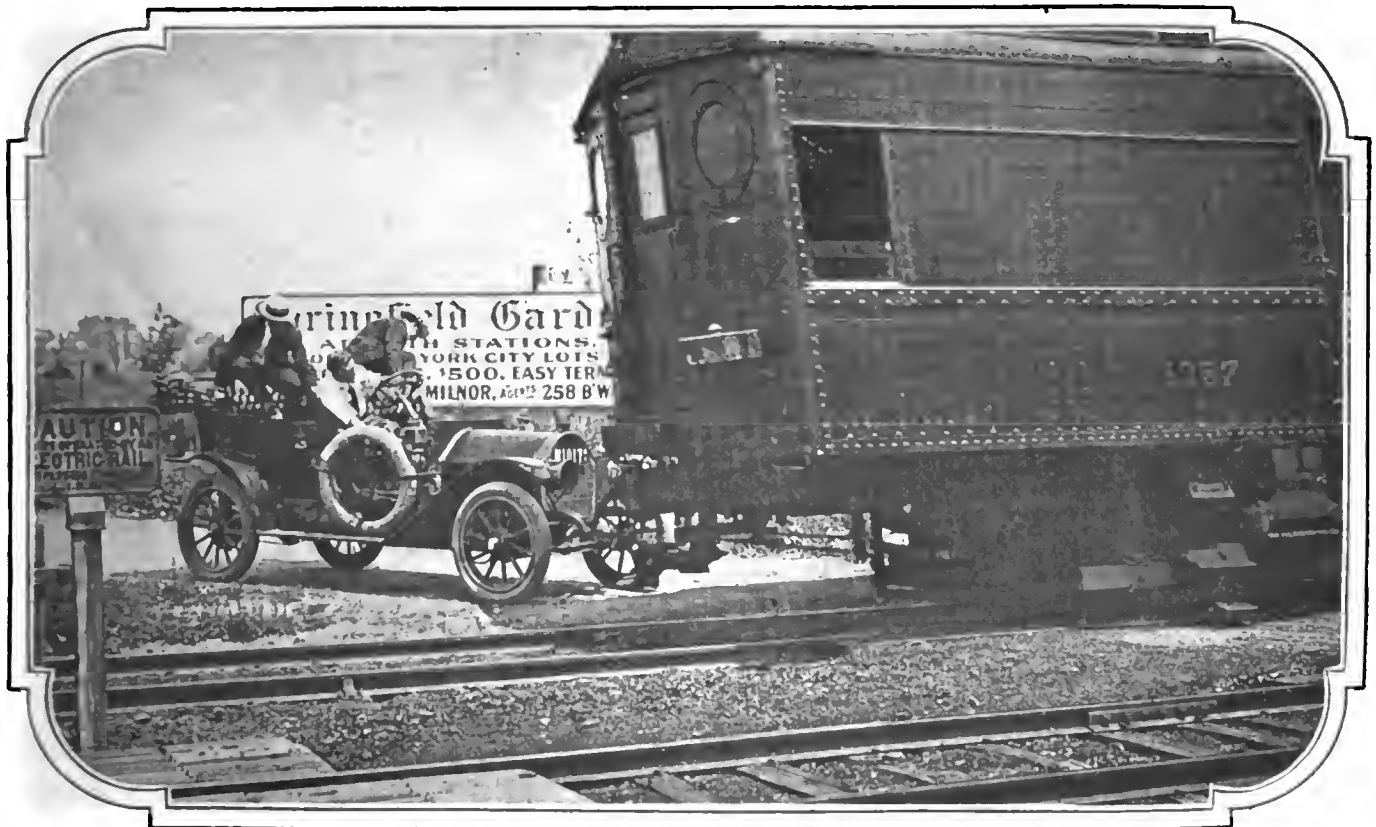

"THE UNDERTAKER," A CROSSING NEAR SPRINGFIELD UNPROTECTED BY GATES

**S**INCE the middle of last May there have been twenty-two legal executions in capital cases in the United States. As all the persons killed by the law were previously convicted and presumably deserved their fate, there was only the usual amount of criticism for the system of punishment that makes legal killings a part of society's machinery. But during

other States. The destroyer sprang at them without warning and crushed and mangled them without mercy. Too late to be of service, the safety devices of the locomotives shrieked their futile warnings and the wailing whistles and grinding snarl of the brakes proved only to be a horrible death knell for the victims.

Since May 15 last eighty-seven persons have been sacrificed on

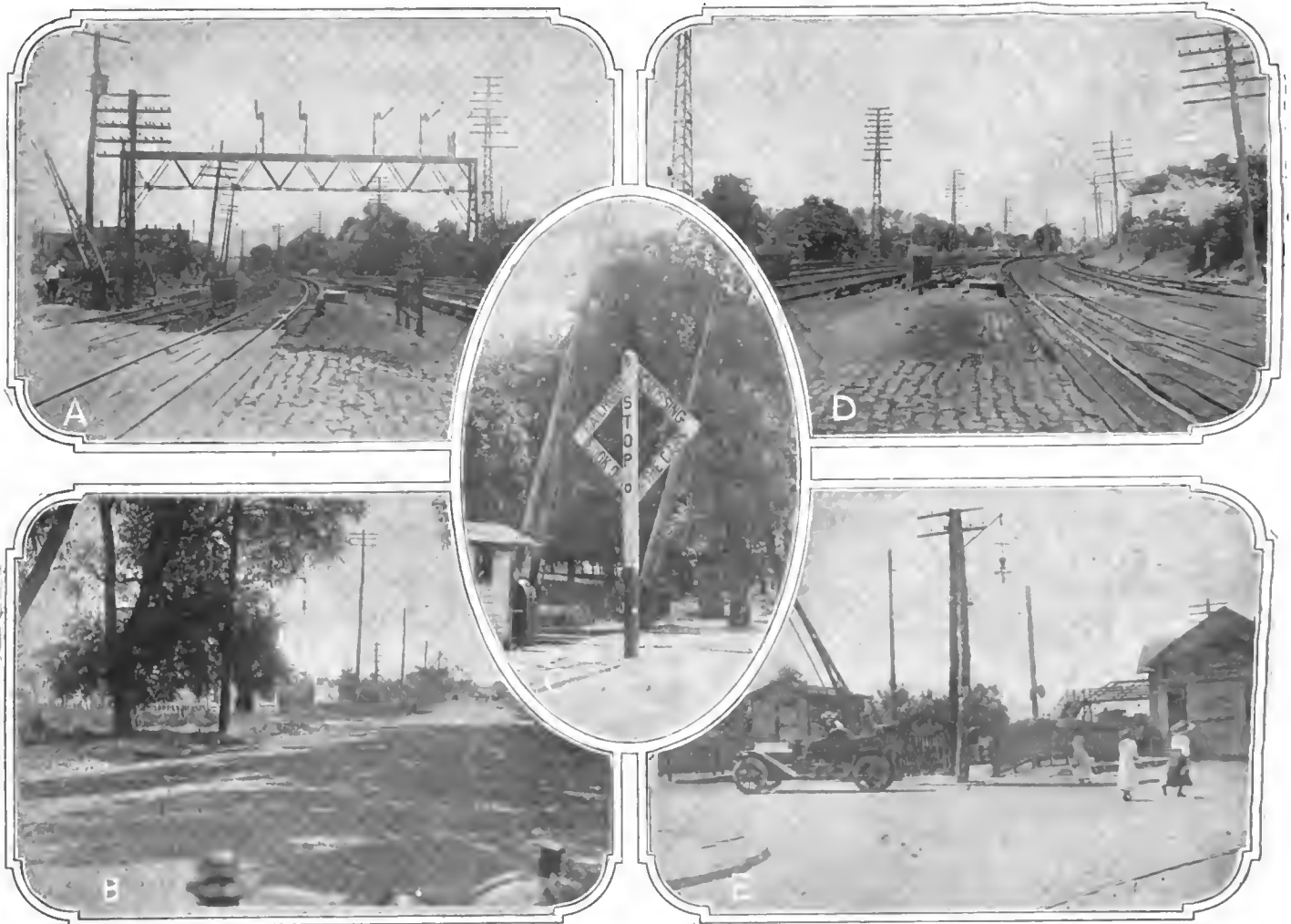

A—Upper curve leading to "Yawning Death" crossing Thompson avenue, Winfield  
 B—The "Silent Tomb" crossing of Thompson avenue

C—Showing poor placing of warning sign at the "Rat Trap" in Elmhurst

D—Something over 350 trains pass this point daily  
 E—The "Rat Trap," where a backing train might cause disaster

the useless altar of the grade crossing. Some were bankers, some lawyers, some business men, some society women, some gentle mothers and some innocent children. Death on the grade crossing plays no favorites and respects no rules, and instead of being useful members of their various communities the victims are now reduced to the ultimate clay.

The grade crossing is an anachronism. It belongs to another time. It never was anything but a peril that was countenanced in the past so that the progress of swift transit might be furthered. To-day there is as little excuse for it as there will be for cavalry in the next great military campaign.

Not one word can be said in favor of retaining a single crossing at grade of any traveled highway in the United States by any railroad. Such crossings add to the cost of operating the railroad property. They make necessary the employment of a host of inferior labor on a job that requires supreme judgment, or in its absence, cataclysm.

With no grade crossings, the railroads could make better time at less expense and if there had been no grade crossings in the United States on May 15 eighty-seven men, women and children now resting under the sod would still be living.

The history of the grade crossing is the history of the railroad up to about the beginning of this century. Prior to that time there had been many improvements urged and agitated, but little of real accomplishment had been done in the line of eliminating them except in the centers of densest population. Even at such points there were numerous crossings that came to be known as death traps, slaughter house curve, the graveyard and by other sinister names. Public opinion has forced the elimination of many of these, but even to-day there are literally hundreds of

such crossings still in existence in the largest cities, and some of the eighty-seven lives that have paid the penalty since May 15 were lost upon them.

To the credit of the railroads it may be stated that in the big towns, at least, a determined effort has been made to safeguard the lives of citizens. Gates and gatemen have been established and where the crossing is approached by a curve from either side, signalmen in a few instances have been provided. Warning signals have been installed in many dangerous places and signs telling of danger are to be met with frequently.

All these things have been done and still eighty-seven lives have been taken from passengers in automobiles and carriages in a little more than ten weeks.

There are two factors in the present system of "protection" of grade crossings. First the mechanical and automatic warnings and guards and second the human agencies that work with the machines and independent of them. Of the first it may be said that they work splendidly as long as nothing is the matter with them, but they are subject to accident and frailty and natural wear and tear and in addition they sometimes fail to work at all without any known cause.

As far as the flagmen and gatemen are concerned, they are only men after all and are neither immortal, infallible or invulnerable. When a brakeman loses a leg in the line of duty he is automatically placed on the eligible list for gateman at a grade crossing. When an engineer is crushed out of shape and disabled he is sometimes made watchman at a crossing. Frequently the veterans who have served long and honorably in the operating departments of railroads, but who have been so unfortunate as to outlive their usefulness in those capacities, are pensioned off by

being allowed to guard the lives of men, women and children at some dangerous grade crossing.

Old age is no crime, neither can a man be blamed for accepting employment after being disabled for his regular work, but the question stands out sharply: Why are such men used to guard the most precious thing in the world—human life?

Let us suppose a case something like this: A grade crossing of six railroad tracks traversing a main traveled artery of commerce. Suppose that this crossing is approached on a curve that prevents drivers of automobiles or carriages from seeing for themselves that the way is clear or the contrary. If there is a flagman stationed on the curve to warn the gateman of the approach of a train, in addition to the other safeguards of an automatic nature, the chances are that thousands of signals may be given with exactness by one or both of the systems, but eventually, a puff of wind will extinguish a lantern, a drop of rain or a pellet of hail striking a man in the eye will put him out of commission for a moment and if at that instant a train is whirling down upon the crossing and if the insulation of the safety signal device should happen to be worn, or the wire grounded in the wrong loop, or any of a thousand different mishaps should intervene, then death looms large for those using the crossing.

The element of frailty in the personal equation cannot be overlooked and just as long as there are grade crossings guarded by frail human beings, just so long will there be terrifying slaughter resulting from the perversity of human nature.

There is nothing that seems to be quite so useless as to try to improve the protection of grade crossings. Whenever a great effort is made to protect a certain crossing, like the one on

Thompson avenue at Winfield, it means that the danger of slaughter at that particular point is tremendous. There is no doubt that it is protected as thoroughly as any in New York City and yet it is reasonably called "Yawning Death" and numbers its dead by the score and its cripples by the hundreds.

All present efforts to protect grade crossings are futile and as they represent the height of human care and ingenuity, it would seem as if nothing further could be done in that line. It would appear that any additional effort to perfect the system of protecting grade crossings is quite as unreasonable from every human aspect as would be the abandonment of existing and prospective subways and rapid transit and the extension of the present horse-drawn surface cars in New York City.

The answer to the problem is to eliminate the crossings, root and branch.

Such procedure is expensive in first cost, but on the part of the railways it must prove economical. Vastly better time will be possible. Vastly less expense will be attached to such operation. But even if it should prove to be a dead loss to the railroads, it would be far better to have the grades eliminated than that the present tremendous death toll should be exacted for even one year more.

The Central Railroad of New Jersey ran down and crushed an estimable party the other day and the Pennsylvania chopped a big touring car to bits and killed four prominent persons near Pittsburg last week, and the daily press recounts a tragedy of the grade crossing somewhere nearly every day, sometimes half a dozen of them.

Consequently, the special attention paid to the crossings of the Long Island Railroad are not intended as a special criticism of

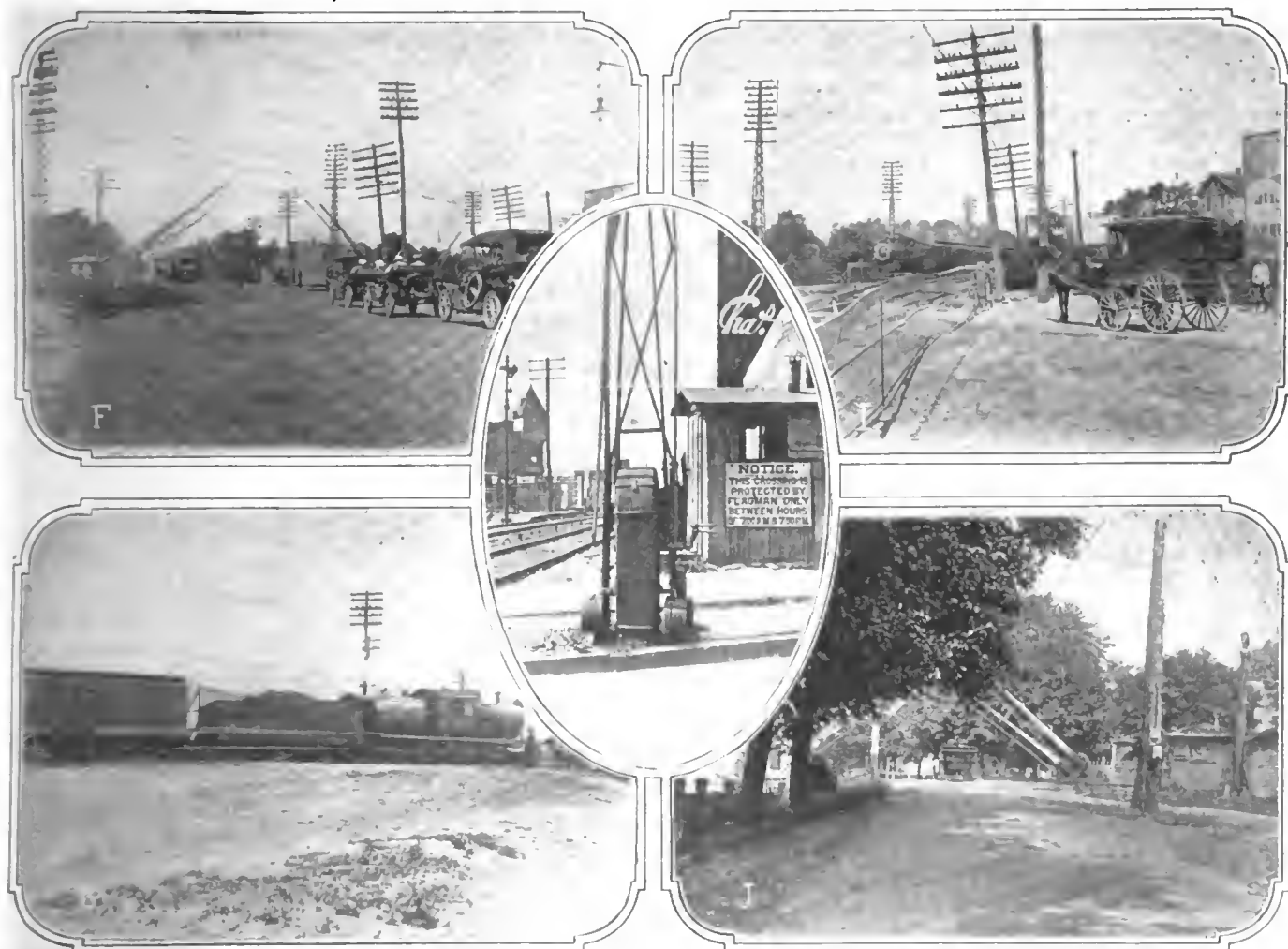

F—Automobiles and other traffic have to wait on passing trains  
G—One danger is where a slow and a fast train travel in the same direction

H—"The Hospital," a greswomely named crossing on Eastern Boulevard

I—With the gates down at the Thompson Avenue grade crossing  
J—"Gates Ajar," a tree-lined grade crossing that has a record

that particular railroad company. In fact, they are probably well up to the average in the matter of safety. The accompanying illustrations, photographed recently at several of the Long Island grade crossings, were taken by the staff photographer of THE AUTOMOBILE, mostly from a Velie touring car furnished for the occasion by the Garland Automobile Company.

The main traveled highway leading from the Queensboro Bridge to the interior of Long Island is Thompson avenue. It is the most convenient route to the north, center and south of the island, and at such events as the Vanderbilt Cup race or other big national functions staged near Garden City it is thronged with thousands on thousands of automobiles. Only a short distance out the road crosses the main line of the Long Island railway and the place is known locally as "Yawning Death." There are four tracks, two east and two west bound, separated by about 20 feet of roadway paved with cobblestones. There are gates, gatemen, signal bells, flagmen up the track on each side at the curves and yet its death list is appalling.

Entirely aside from the fact that it is one of the most popular haunts of The Reaper, the crossing is an unmitigated nuisance. Half the automobile commuters living on Long Island are obliged to pass "Yawning Death" at least twice each day and as something over 350 trains shoot over this crossing every week-day, the delays occasioned by shut gates have proved a deterring influence to the general use of the automobile.

Many a man would own a car and use it in commuting if there was no such thing as "Yawning Death" to spoil his temper, make him late for dinner or perchance snuff out his life.

A little further along is another crossing known as the "Silent Tomb." This also has a bloody history, being particularly treacherous at night. "Silent Tomb" is protected by gates, but west bound trains are concealed from view by the beautiful trees that line the avenue and buildings that stand close to the tracks.

The "Rat Trap" at Elmhurst is another magnificent example of the grade crossing. Approaching from the west, all east bound trains are hidden by the station house, while the automobilist who comes to the crossing from the other side is cut off from view by trees and houses. The chief danger at this crossing in daytime would develop if from some untoward circumstance the gates should not be lowered when the train happened to be backing across the street. At the time the representatives of THE AUTOMOBILE visited the "Rat Trap" a train did back down across the street, but the gateman lowered the barrier in plenty of time.

The "Hospital," as the crossing on Eastern Boulevard is called locally, is as dangerous a grade crossing as there is in New York. The tracks shoot out from behind the buildings and, according to the posted warning, gates are not in commission from

7 o'clock in the morning until 7 o'clock at night. Mothers in the vicinity are accustomed to warn their children in starting out to school: "Now be careful or 'The Hospital' will get you." The record of "The Hospital" is not bloodless.

"Gates Ajar" is the name of another crossing near Elmhurst. The name probably does not refer to the fact that the protective gates are raised when no trains are in sight. The residents of the vicinity in all likelihood imposed the name from some similarity they found between the crossing and the well-known and appropriate funeral floral piece.

But the most dangerous of the lot is the crossing of Palmer avenue, near Springfield, by the beach branch of the railroad. This road is now the most heavily traveled by commuters and tourists, owing to the fact that the regular route over the Merrick road is undergoing radical repairs.

At the point shown in the accompanying photograph and which is called "The Undertaker," there are no gates, or at least there were none the day the inspection was made. "The Undertaker" enjoys a few advantages, despite the danger that resides in lack of gate protection. The tracks are visible for quite a distance to the north and are only concealed from view to the automobilists approaching from the east. The motive power used on this branch is mostly electricity and the silent trains give absolutely no warning.

The six crossings, "Yawning Death," the "Silent Tomb," the "Rat Trap," the "Hospital," "Gates Ajar" and "The Undertaker," all have known records. In fact, the residents of the district presided over by "Yawning Death" state with all sorts of emphasis that the slaughter officially charged against that crossing is only a small part of the actual total casualties. But when all has been said, these crossings are only typical of grade crossings everywhere. The railroad would be very glad to lose the whole six overnight and the public would be equally relieved. The same may be said for every grade crossing in the land.

The fact that the crossings do exist has held back realty values in Queensboro; has discouraged settlement of many of the open places and consequently has added to the congestion of Manhattan Island. Numerous killings have resulted; more numerous injurings and destruction of property and under this head must be reckoned the loss of revenue to the railroad company by reason of slow operation as well as the actual loss represented by additional operating expenses. But besides all these things, anything that tends to make the use of the automobile perilous or that which detracts from the pleasure and benefit of automobile operation, reacts as a deterrent influence upon the automobile business.

In this way the makers of automobiles are interested in the grade crossing problem, quite aside from their natural human instincts of horror at the slaughter and maiming of their fellow citizens.

When the tracks are raised, and it has been announced that provision has been made to eliminate "Yawning Death," "Silent Tomb" and one or two others, the greatest obstacle to the welfare of Long Island will be removed. It is said that it will cost \$2,500,000 to do this work and that the city will pay \$600,000 as its part.

The legal price of a human life used to be \$5,000, but it has been raised somewhat lately. Supposing that only ten lives a year, appraised at \$10,000 each, are saved by this expenditure, the amount of saving would be \$100,000 or 4 per cent. upon the investment. This is at least savings' bank interest on the bonds that would be issued and in addition to that rather comfortable sum the railroad would be adding materially to its gross earnings from operation and

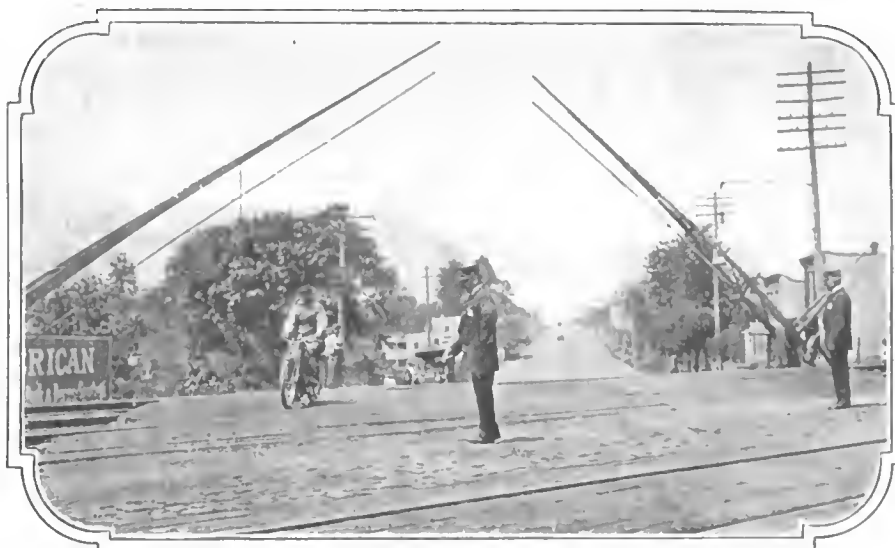

Looking west from Winfield crossing



decreasing its operative costs by reason of the better condition of its right-of-way. Neither of these items takes into consideration the saving to individuals in property, automobiles, carriages, baby-buggies, etc., that will not be destroyed on the grade crossings.

Thus, besides being dangerous, the grade crossings are uneconomic and their purpose would be better served by elevating the traffic of the railroads and depressing the surface of the streets, or the contrary as the circumstances of the particular case may warrant.

President Peters of the Long Island Railroad was quoted as saying immediately after a recent multiple killing at Winfield that the railroad could do nothing more and that the only solution of the problem was to eliminate the grade crossings.

He knows as well as any railroad man that the limit of human effort has been made to protect life at this crossing, and when he says that nothing further can be done it simply means that the crossings must be eliminated as quickly as possible.

Carelessness might account for a few of these accidents, recklessness on the part of drivers has been blamed for some, but deep down and beyond there is the crossing itself—sufficient unto itself to account for the bulk of the slaughter.

## Items from Foreign Lands

*What the English are doing in the matters of the testing of road materials, Sunday opening of automobile supply stations, keeping learners off the busier roads, etc.—Statistics show a decrease of horses in the French capital.*

**I**MPORTANT tests of twenty-three different kinds of road materials are being carried out jointly by Kent County Council and the Road Board on the main London and Maidstone road, between New Eltham and Sidcup. Trial lengths are being laid with various materials, the work is conducted under the supervision of the Advisory Engineering Commission of the Road Board.



Scene of recent fatal accident

English automobilists are making strenuous efforts to influence the Government to insert a clause in the proposed Shops Bill (the Parliamentary Act to regulate Sunday openings) which will permit dealers in automobiles and motorcycle accessories to sell parts, gasoline, lubricants and so forth to motorists who travel on Sunday.

The secretary of the North-Eastern Automobile Association (England) has addressed a letter to the press with regard to learners of motor car driving on the public highways. The association also extended copies of the letter to garage proprietors and motor-car agents in the North of England, requesting them to discountenance as far as possible the giving of lessons to learners on busy roads. It points out that danger can practically be eliminated if care is exercised in the selection of straight and little-used roads for the purpose of giving lessons.

Statistics which have just been published in Paris, France, show that there has been a decrease of 24,210 horses there within the last ten years. In 1901 there were 96,698 horses in the city, as compared with 72,488 at the beginning of July, 1911. One omnibus company has 6,500 horses less than it possessed in 1901, while in some of the city wards there has been a falling off in number of horses to fully 50 per cent.

# “On to Richmond” by Automobile

## Description of Best Routes to Virginia's Capital

*Next November there will be held in Richmond, Va., the most important Good Roads Congress of the year. This gathering will doubtless attract many automobilists from the Northern cities. The following description (reinforced by photographs and an accurate map), which was prepared from the records of the pathfinders of the Touring Club of America, who explored the section in the search for the most feasible routes to the famous capital of the Confederacy, will therefore be most timely.*

**T**OURISTS who contemplate making the run to Richmond in November on the occasion of the Good Roads Convention in that city, will find that there are two distinct routes to that historic city, both of which are replete with scenic and historic interest.

Naturally the first itinerary that suggests itself is via Phila-

delphia, Baltimore and Washington. This, of course, is the shorter and is the route followed by the pathfinder cars of the Touring Club of America on their recent journey southward. The roads across Virginia on this trip, however, are so bad that doubtless the weary tourist will be glad of any other option on the return trip.

While 87 miles farther, the return trip via Staunton, Hagerstown, Harrisburg and Easton may be made in less time because no large cities are passed through and the roads on the average are much superior.

From New York City several distinctly good macadam routes lead to New Brunswick, N. J. The most direct route, however, is that via Newark and Elizabeth, a distance of 25.3 miles. Elizabeth is a residential and manufacturing city. So is New Brunswick, being largely interested in rubber and harness. It holds also one of the termini of the Delaware and Raritan Canal, which runs to Bordentown, on the Delaware, and originally cost \$4,-



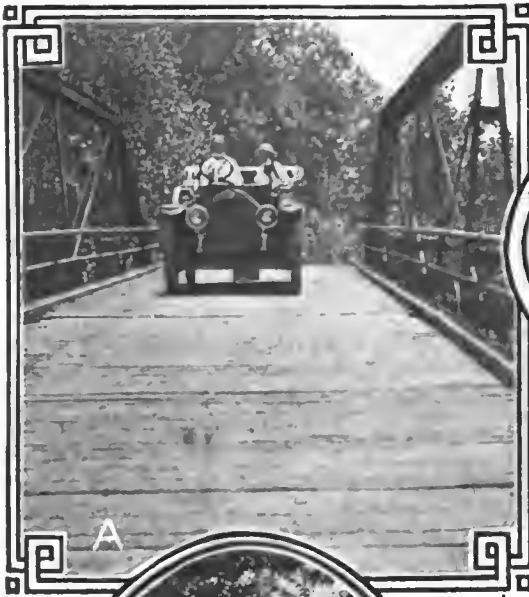

A



A—Bridge over Bull Run, near the famous battlefield (See route variation on the map)

B—Orange Court House, showing one of the soldiers' monuments for which this section is famous

C—Monument Avenue, Richmond, with the equestrian statue of General Robert E. Lee

D—Fairfax Court House—George Washington's will is recorded in the office of the County Clerk



B



D

there to escape the attack of mutinous soldiers in the City of Brotherly Love. The battlefield of Princeton is about a mile and a quarter from the village proper, on the old road to Trenton, known as Mercer street. Here the patriot army met and defeated the British regular troops.

Trenton has many historic points of interest, besides a leadership in the manufacture of pottery and fire clay and the command of the market gardening which supplies New York and Philadelphia. The Quaker City, 35 miles beyond on the best route via Langhorne and Bustleton, is noted for its lukewarm hotel interest in touring motorists and for its Independence Hall, also its City Hall, the

500,000. On the banks of the Raritan, New Brunswick is perhaps best known as the seat of Rutgers College. Like much of the neighboring territory, the buildings of the college were burnt by the British during the Revolution, but during the present century it has advanced considerably, adding a model farm of 100 acres and the State College for the Promotion of Agriculture and the Mechanic Arts.

Leaving New Brunswick on fine State roads, the motorist passes through Monmouth Junction and Kingston into Princeton, the home of Princeton University and one of the chief historic towns of the country. Its name dates from 1724, although the vicinity was settled fifteen years before the end of the seventeenth century. It was then Prince's Town, and is still according to enthusiastic inmates of the university. William Penn is responsible for giving impetus to the settlement there by introducing a number of Quaker families, whose little stone meeting house with its graveyard near at hand may still be seen. But for real genuine luster one seeks out the university. Its Nassau Hall was used as barracks by British soldiers, then as a stable and again as their fortress. Twice the Legislature of the State held its sessions in Nassau, and the Continental Congress fled

largest building in the world, covering 41-2 acres, exclusive of the court and costing upward of twenty millions of dollars.

From City Hall the route to Baltimore and Washington lies west on Market street over the Schuylkill and out to Darby over some neglected streets. When the smooth road is reached finally, there is that disagreeable experience of the mile-apart toll-gates reaching to Wilmington, where the traveler crosses the historic Brandywine, near which was established, at the old Swedes' Church, the first Swedish colony in America. From Wilmington, magnificent macadam stretches to Newark, where Delaware, more progressive than Pennsylvania or Maryland, permits the traveler to enter untaxed. On account of the poor condition of the direct road from Newark to Perryville, the following detour (taken from the *Automobile Blue Book*) is recommended: From three-corners at railroad station, Newark, run straight ahead across tracks on direct road through Appleton, Fair Hill, Blue Ball into Calvert. Bear slightly right at five corners and take left fork into Rising Sun. Thence via Battle Swamp into Perryville.

The inevitable toll road leads into Baltimore, the metropolis of Maryland, stretching along the pleasant hills which border a deep estuary of the Patapsco River, 14 miles from Chesapeake



E—Libby Hill Park, one of Richmond's breathing spots, with Soldiers' and Sailors' Monument

F—A glimpse of Bull Run—the fighting raged furiously back and forth across the shallow stream

G—Convicts working on the roads just outside of Gordonsville, Va.

H—Monument at Louisa Court House commemorating the deeds of the Confederate soldiers in the late war



Bay. A stream called Jones Falls divides the city into two parts. Fires more than wars have been the cause of Baltimore's disasters, particularly the great fire of 1904, devastating an area of business property amounting to 150 acres. Johns Hopkins University, renowned for its high standards in medical training, lies along West Monument street. Baltimore is often called the "Monument City," because of numerous testimonials to great men or great deeds of the past, and it has numerous public pleasure grounds, the finest of which is the 700-acre tract called Druid Hill Park.

North on Charles street from Washington Monument in Baltimore one takes the best available trunk route to Washington, D. C., 44 miles away, by striking Edmondson avenue and following the picturesque "Rolling Road" into Relay. So odd a name is due to this place having been the station where changes of horses were made on the first railroad built in this country. At Bladensburg is an old tavern, reached after five miles of jouncy road at Beltsville. Thence the route turns right into Maryland avenue, passing through the beautiful Capitol grounds into Washington.

The pathfinders of the Touring Club of America, by careful study and covering two of the routes between Washington and Richmond, have laid out the following trip, which is entirely practicable although having some very rough stretches. This trip follows a very direct route to Fairfax Court House, which is of peculiar historical interest on account of its having been the place where Washington's will was probated in the year 1800, in which year the present court house was built. The original will is preserved in the Hall of Records in a glass case. There also one may see an original letter from Henry Clay and another from Patrick Henry. The old records date from 1742, but the marriage and birth records were destroyed by the Union soldiers. In front of the Court House is a monument commemorating the

killing of the first soldier in the Civil War June 1, 1861.

The route now follows the old Middleburg Turnpike, travel over which is, to say the least, an uncomfortable experience. The pike is composed of crushed field stones whose sharp angles remain unsoftened under the hand of time. On the hills vehicles have turned off the pike and their tracks have cut into the road so that now these side roads will permit the passage of only one vehicle and they must be entered with caution. At that they are preferable to the bumpy surface of the old pike. At Aldie, 39 miles out, a better road is reached which leads through Middleburg, a pleasant little village with tree-lined streets whose overhanging boughs brush the sides of the car. At 45 miles a stretch of winding macadam is encountered, which leads through plains where is located the Orange County Hunt Club. Beyond this is clay road with frequent culverts and stony spots. A four-mile stretch of macadam is again encountered at Bethel which lasts all the way to Warrenton, where there is a nice little hotel and new garage. For the ordinary tourist, getting a late start out of Washington, it is recommended to make a night stop at Warrenton. By rising early the next morning the trip can be easily made into Richmond.

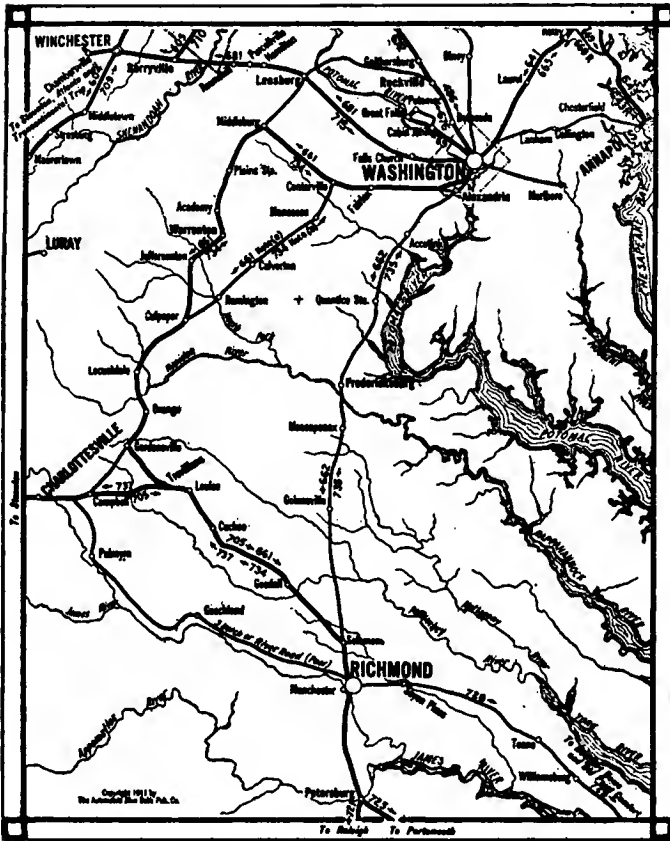

Map showing the best routes between Washington and Richmond, with connection for the South and Southwest (Courtesy of Blue Book)

From Warrenton the direct road to Culpeper is the worst of the trip. The route across to Remington is therefore recommended. Beyond Elkwood a stretch of macadam is encountered which runs with one stretch of clay across to Waverly. The only bad part between Warrenton and Culpeper is the ford across

Jonah Run. This should be crossed with care after rains. The T. C. A. pathfinders have some moist recollections of its passage. Culpeper is interesting historically, as several battles occurred in the vicinity and monuments commemorating these may be seen from the road, which now cuts through an old re-doubt. Culpeper harbors some very vindictive automobile haters; and on one occasion a fine of \$500 and thirty days in jail was imposed on an automobilist for frightening a horse. On the recent good roads tour a fine of \$25 was imposed on the driver of one of the cars for "speeding"—and that on a road which is one of the worst in all Virginia!

After leaving Culpeper a welcome stretch of macadam is arrived at near Orange. It is only a short distance thence to Gordonsville, where much work is being done on the road by convict labor. The barracks of the convicts are to be discovered in the vicinity by the curious visitor. Beyond Gordonsville the road follows the line of the Chesapeake & Ohio Railroad with numerous crossings which are all more or less dangerous. Louisa County is one of the oldest in the State, having been cut off from Hanover in 1742. A warm welcome awaits the tourist at Louisa Court House, which holds the record for never having arrested an automobilist; while the good old Virginia fried chicken may be indulged in to the heart's content. The inner man replenished, one may proceed leisurely, for the roads improve as the city is neared.

This part of the country is full of Civil War memories. About six miles beyond the Chickahominy River is the site of the old Yellow Tavern, where J. E. B. Stuart fell. A monument commemorates this. Entering Richmond by the official route the traveler passes Washington's monument and later those of Jefferson Davis, Robert E. Lee and J. E. B. Stuart, the route terminating at the Jefferson Hotel, which contains a marble statue of Thomas Jefferson in the rotunda.

The return trip from Richmond is, as previously suggested, preferably made via Staunton and the Valley Pike. It passes through Winchester to Hagerstown. From Hagerstown a good road is followed to Harrisburg, a fine pike to Reading and excellent macadam the remainder of the way through Easton and Morristown, with a choice of several routes from the last-named place to New York City.

## Some Recent Electric Products

### Leading Concerns Make Improvements in New Models

*The popularity enjoyed by electric vehicles in their own particular field continues to grow apace with that of the other motor-driven vehicles, and the enthusiasm of their makers seems to be highly justified when the ever-increasing use of electrics is taken into consideration. Products of the Louisville Electric Vehicle and Broc companies are particularized.*

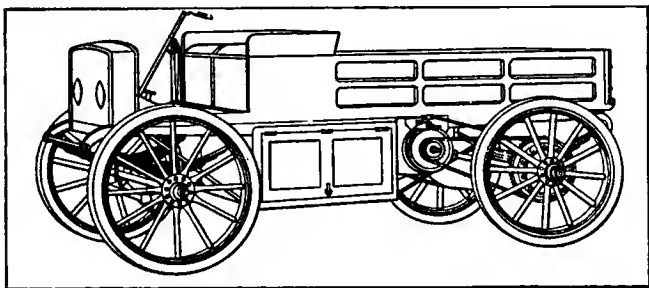

Illustrating the chain drive on the product of the Electric Vehicle Co.

**T**HE Electric Vehicle Company, of Louisville, Ky., has recently brought out two models of light electric delivery cars which represent an effort on the part of the designers to produce a car which will have a long life, low cost of upkeep, high mileage capacity, accessibility and convenience of manipulation for the operator.

The motor, which is manufactured by the General Electric Company, is supported by the car frame just forward of the rear axle. The power is transmitted from the motor to the countershaft by means of a silent chain encased in a dust-proof housing of sheet steel. From the outer shaft to the rear wheels the power is transmitted by means of roller chains. The motor shaft is supported by Hess-Bright annular ball bearings, while the rear wheels are equipped with Bowers roller bearings.

The battery is mounted on a subframe carried just forward of the countershaft. In connection with the 600-pound car the battery used consists of a thirty-cell, eleven-plate lead outfit, while the 1,000-pound wagon carries a battery of fifty A-4 Edison cells. The battery equipment, under normal conditions, will give the car a mileage of from 40 to 55, but if required a heavier battery equipment will be supplied.

The controller is of the continuous torque type, giving four speeds ahead and two reverse. It is located in a rather unique position, being bolted to the dash and covered by a short hood. The wiring of the controller is rendered accessible by removing the dash panel which is held in place by four thumb nuts. The hood besides protecting the controller also serves to protect the headlamps, meter and switches, leaving the body free from the wiring so that it may be removed from the car frame by removing the six bolts which hold it in place.

The frame is built up of channel-section, pressed-steel side members with three gusseted transverse members which are of the same section as the side members. The forward and rear transverse members are connected by truss rods which insure the frame against sagging and give a very light construction. The axles are of I-beam section, being seamless forgings, while the steering knuckles are of reversed Elliott type. All the wheel bearings are of the Bowers type. The springs are semi-elliptics, both front and rear, made of crucible stock.

There are two sets of brakes. The service brakes are contracting bands acting on drums riveted to the countershaft sprockets and applied by a pedal through an equalizer. The brake bands are 8 inches in diameter and have a 2-inch face. The emergency brakes are of the expanding type operating in drums attached to the rear wheels. The brakes are applied by a hand lever and are also equipped with an equalizer. The steering apparatus consists of a semi-reversible worm and gear mechanism working on ball-bearings. The steering column is sloped at an angle of 25 degrees from the vertical.

The car has left-hand control. The control outfit consists of a controller lever and emergency brake levers and is placed on the right-hand side of the driver in the center of the car, the driver being seated on the left-hand side of the car. The service brake pedal is operated by the driver's right foot. The control lever is moved forward for the four forward speeds, and backward for the two reverse speeds. Before passing from the forward to the reverse speeds a latch must be removed, thus providing a safeguard against accidental reverse. The emergency brake is applied by pulling the lever to the rear. An emergency lock switch is provided which opens the circuit when a plunger is pulled out. The plunger locks in open position and may only be returned by use of a Yale key providing against unauthorized use of the car. Lubrication is carried out throughout the car by means of grease cups which are all carefully protected.

### The Shaft-Driven Broc

The Broc Electric Vehicle Company makes six models of electric pleasure vehicles with the shaft drive, the main difference in the models being in the body while the mechanical features are about the same in all the models. The controller is of the continuous torque drum type with five forward and five reverse speeds on the same lever, giving a smooth acceleration of speed without jerking the car or wasting current. A pedal prevents accidental reverse. The controller is equipped with a cylinder lock so that the car can only be started with the owner's key. To prevent the car being accidentally started when the key is inserted, the lock is arranged so that the key can only be admitted when the controller is at the standstill position. The same key fits the doors of the coupé.

The braking system is double, permitting of gradual or quick stopping and assuring safety on steep grades. It consists of a pedal system of expanding Thermoid-lined brakes operating on both rear wheels and a brake operated by the controller lever without using current. When the operator desires to stop he shuts off power, a continuation of this motion applies the brake.

The springs are seven-leaf, semi-elliptic front and three-quarter-elliptic rear, made of special high-grade spring steel, oil tempered and hand fitted, fastened by oil groove bolts provided with grease cups. The rear springs are attached to the frame at two points dividing the weight and lessening the strain on the frame.

The power is transmitted from the motor to the countershaft

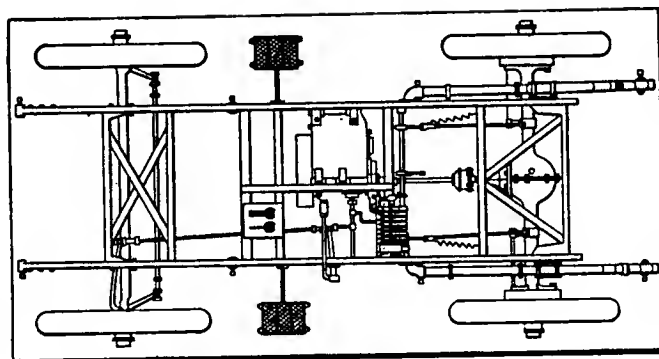

Chassis of the Broc Electric, showing method of supporting motor

by a special drive, self-adjusting as to pitch, and enclosed in a dust-proof oil-retaining case. Adjustment for length between the motor and the countershaft is made by an eccentric, without disturbing the case. The transmission is carried from the countershaft to a rear axle by a bevel gear shaft. The drive shaft is of vanadium steel, and all gears in rear housing are made from special steel with planed teeth carefully hardened and ground to gauge within limits of 0.00025 of an inch. Free movement of the rear springs is permitted by the straight line transmission with two universal joints.

The rear axle is of vanadium steel, semi-floating type with a drawn-steel housing. The bearings are of the ball type with a positive locking device for adjustment.

The motor is four-pole series wound designed to stand a heavy overload if necessary; it has a wide speed range and is designed to cut down the current consumption on hills to a minimum. The wiring is direct, without resistance coils for low speeds. It is acid- and weather-proof and secured against mechanical strains, the wire cable being covered with 30 per cent. rubber. The steering gear used on all types of body except the roadster is of the folding side-lever type. On the roadster a steering wheel is provided. Ball and socket connections between the steering post and reach rod take up the vibration when driving over rough roads.

The body equipment on all types of cars is complete and has been carefully looked after with the comfort of the owner in view.

## Care of Battery Terminals

*The dry batteries used on automobiles have reached a state of high perfection, but they have not reached a point where they can be neglected and expected to perform their work in a satisfactory manner. The trouble is often in careless connections.*

ONE of the greatest causes for the necessity of calling for the aid of the friendly horse in the early days of motoring were the dry batteries employed as the sole means of furnishing the ignition current. Nowadays nearly every car is equipped with a magneto and the dry cells are used merely in starting the machine. In this capacity they are satisfactory since the work is merely of an intermittent nature.

A great many motorists have trouble with their dry batteries because they do not give them the proper care and attention. In order to have a current of sufficient amperage and voltage it is necessary to connect several cells in series or multiple. This is done by means of short insulated wires which are apt to come loose with a very little vibration. If one terminal is partially disconnected, the whole battery is practically dead, therefore all connections on the primary circuit must be clean and absolutely bright.

Care should be taken to place dry cells in a dry insulated box and to arrange them so that the excessive vibration does not cause them to chafe. A troublesome short-circuit may often be traced to this cause.



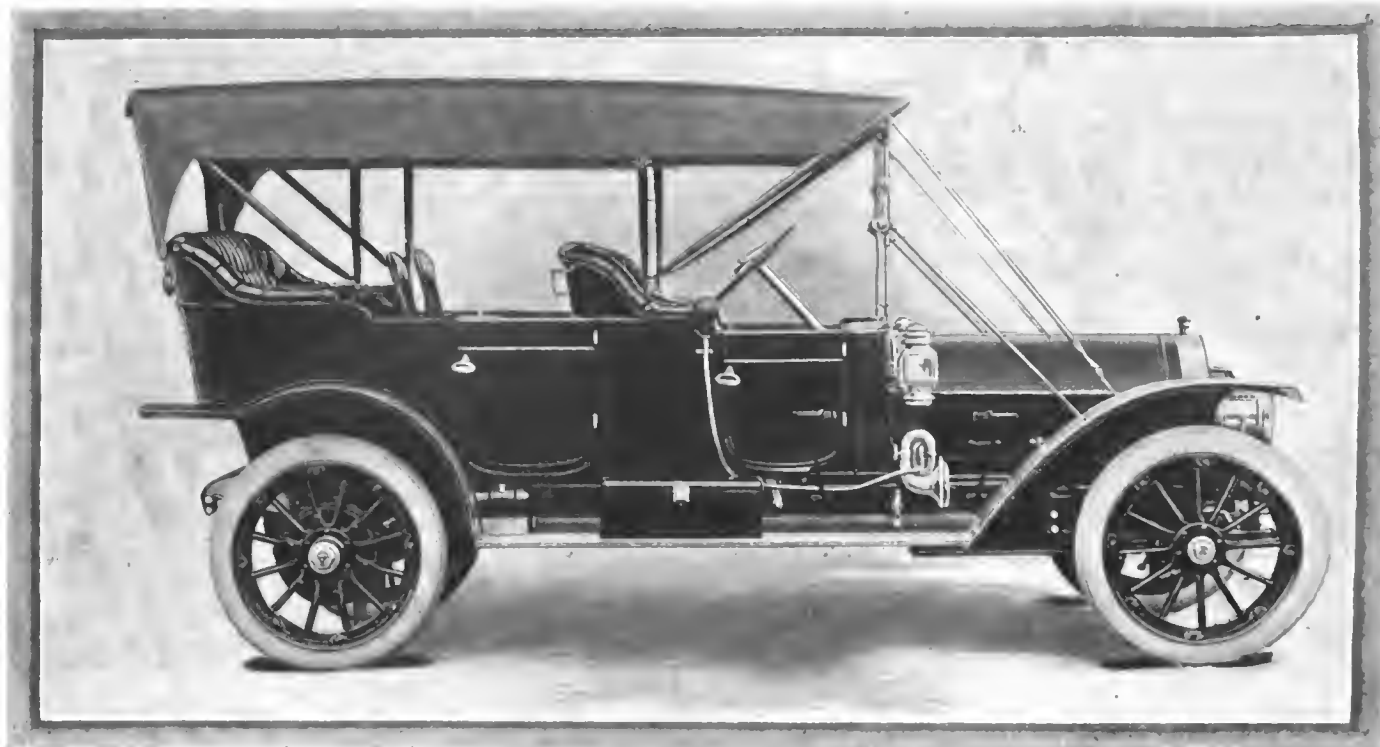

Fig. 1—Model AA Standard seven-passenger touring car, with four-bow top

## Six-Cylinder Stevens-Duryea

### Mechanical Aspect of the Car

*The latest model of the Stevens-Duryea Company, Chicopee Falls, Mass., follows along the line of last year's endeavor. An interesting addition on the Model AA is a permanent air pump for tire inflation. The unit power plant with three-point suspension has been maintained as heretofore, and with the exception of a few refinements the car has remained practically unchanged.*

THE motor of the Model AA Stevens-Duryea has six cylinders, 4.1-3 bore and 4.3-4 inch stroke, cast in three sets of two, as can be seen by referring to Fig. 5. The cylinders have T-heads with the intake and exhaust valves placed on the left-hand side of the motor. The flywheel is housed in the extension casing behind the motor, and the crankshaft, which has four main bearings, being machined and ground to close limits, is made from a forging of special crankshaft steel. Two bolts are used to secure the cap of the big end bearing to the connecting rods, and brass shims introduced to facilitate adjustment. White metal is used on all big ends of connecting rods and main bearings. The crank chamber is cast from aluminum, and the cylinders are bolted to it.

The six-throw crankshaft is mounted on four bearings in the crankcase, with two cranks between each pair of bearings. The boxes at these points are connected with the lubricator, the lower half of the crankcase forming a reservoir for oil escaping from the main bearings. The connecting rods dip into this, and the piston, connecting rod bearings and rotating members inside on the motor base are supplied with lubricant from the ensuing splash. The half-time shafts, mounted in the crankcase on either side and parallel to the crankshaft, are driven from it by enclosed gearing as shown in Fig. 9. The main gear wheel G<sub>1</sub>, which is attached to the crankshaft, drives the half-time gears

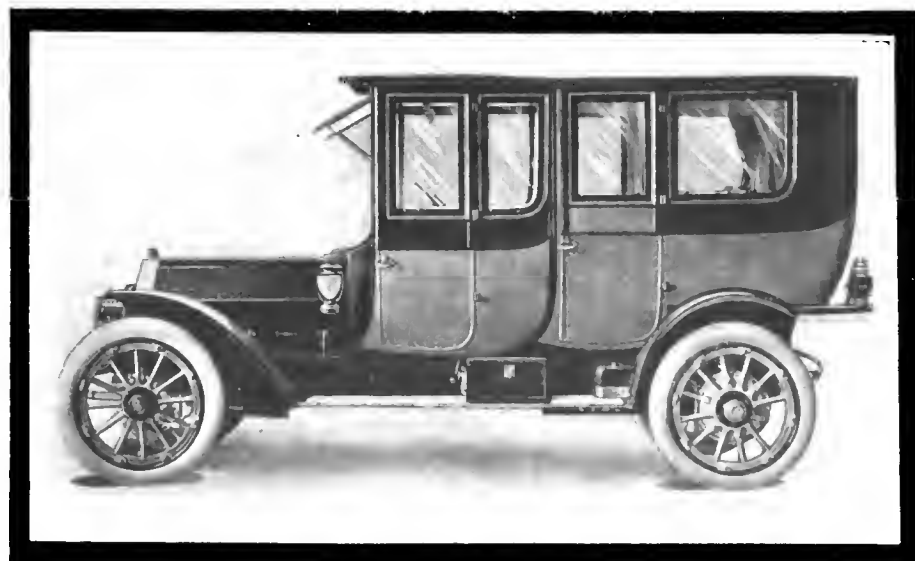

Fig. 2—Model AA Stevens-Duryea seven-passenger Berline



G2 and G3. The gear G3 operates the camshaft and the small pinion G4 serves to drive the magneto M, which rests upon a ledge cast integral with the base chamber and held in position by two spring steel bands united by the clasp C. The gear G2 operates the centrifugal water pump which forces the water from the radiator through the pipe W1 in Fig. 7 around the cylinder walls and valve chambers and passing therefrom through the pipe W2 back to the cellular radiator. The radiator R1 is shown in Fig. 6. The water leads W1 and W2 are united to the pipe leading from the radiator by a rubber connection R.

The method of attaching the intake manifold I and the exhaust manifold E to the cylinders is shown in Fig. 6. A single pipe E with the extensions E1 and E2 formed integral therewith are held in position by the strap S1 and the bolts F1 and F2. The intake manifold I is held to the cylinders by the same strap

S1, a separate nut and bolt, however, being used to permit this part of the mechanism being dismantled independently. The respective manifolds are surface-ground on the face that contacts with the ground surfaces of the cylinder ports. The carbureter C1 is attached to the manifold in the manner shown. The gasoline is supplied from a tank located under the front seats, and the air supply is taken in at the bottom of the carbureter through a small pipe connected with the exhaust manifold. Additional air is provided by means of an automatic air valve. The mixture is controlled by a butterfly type of throttle valve operated by a lever above the steering wheel, and also by a pedal. The vertical tube above the throttle is water-jacketed to assist the vaporization of gasoline at slow speeds and prevent condensation in cold weather. Two valves for cutting off the gasoline supply are fitted directly below the tank, and are operated from outside the chassis frame by two hand levers. A

three-gallon auxiliary tank is provided as a stand-by and for emergency. A gasoline gauge, the dial of which is placed directly beneath the front seats, is an integral part of the tank.

At the forward end of the camshaft a spur gear is attached that drives the tire inflating pump P, the gear G3 being held out of mesh with the gear G4 when the pump is not being used.

The ignition in each cylinder is effected by the Bosch double magneto and battery system, with a separate set of plugs for each system. The current for one set of plugs is generated by means of an independent high-tension magneto connected by spur gear with the camshaft; and the other by battery and single-induction synchronous coil located on the dash, fitted with kick switch, push button and special key lock. The timer distributor for the battery system rotates on ball bearings, is absolutely dust-proof and most accessibly located under hood on right side of motor.



Fig. 3—Three-quarter view of the five-passenger fore-door touring car

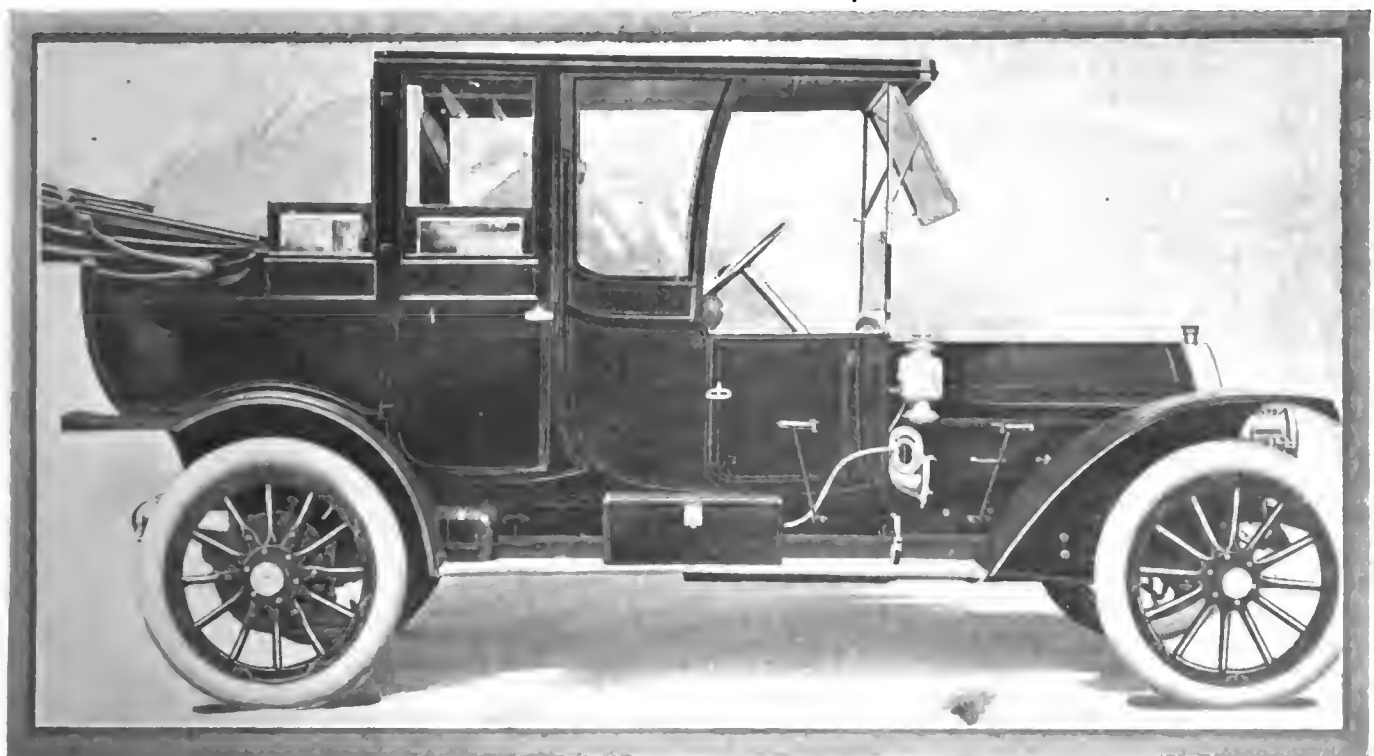

Fig. 4—Three-quarter Stevens-Duryea landaulette fitted to a Model AA chassis

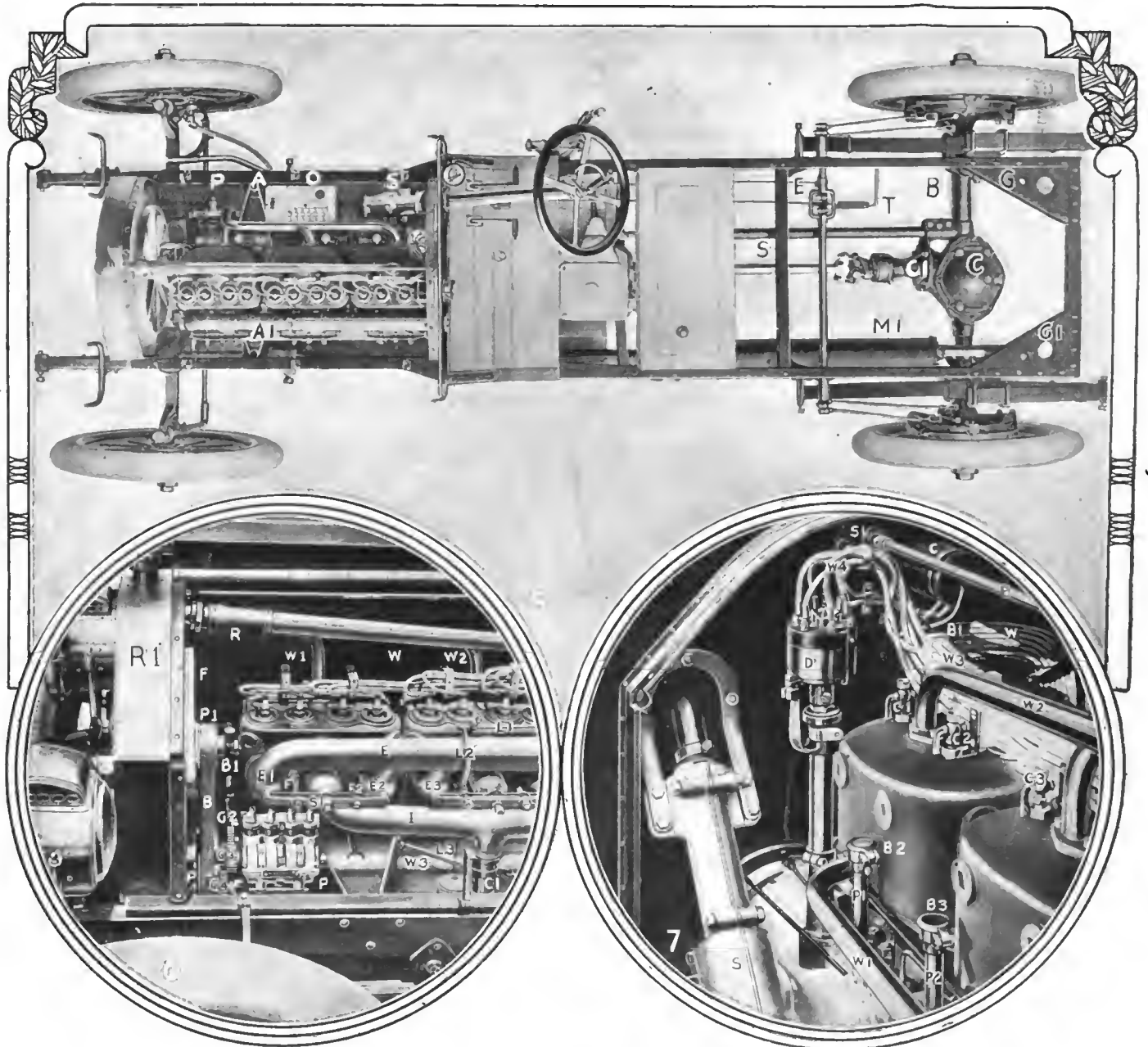

Fig. 5—Plan view of the model AA chassis showing the six-cylinder motor and the live rear axle. Fig. 6—Front end of the motor showing tire inflation pump. Fig. 7—Right-hand side of motor, showing distributor and coil on the dash

The magneto driving shaft runs on imported annular ball bearings, while interposed between the magneto and end of shaft is a universal coupling with a special coil spring tightening it absolutely quiet. An easily movable clip holds it to its base, and particular care is taken to render the contact breaker accessible. Wiring is led in such a way that the wires to be traced easily.

At the forward end of the crankshaft there is a pulley driven by means of a flat belt; the forged crankshaft is attached to the motor base, while the connecting rod is adjusted by coil spring pressure. The magneto is driven, while a greaser takes care of the bearings. To be appreciated is the provision for adjusting the valves and ignition.

The distributor is situated on the right-hand side of the motor, and is covered by hinged covers B1 and B2 which are bolted into the crankcase. Commutator brushes are shown in C1, C2 and C3, and are adjusted by passing a wire down from the top of the piston at any point of the stroke, and connected at the rear end to the

dashboard and at the forward end acts as a support for the radiator. The motor is suspended by the two arms A and A1 in Fig. 5, which rest upon the side frames, and as the power plant is of the unit form of construction, with the motor, clutch and transmission encased in a single rigid member, the rear end of the assembly is attached to one of the cross members. This method of assembly eliminates the lining up of the various units and intermediary universal joints.

The clutch, which is of the dry-plate, multiple-disc type, has nine polished steel discs contacting with eight plates double-faced with woven wire and asbestos, having a self-contained thrust. The driving member end of the clutch is connected to the extension of the shaft by square clamps. A ball-bearing ring releases the clutch by means of a forked lever operated by the clutch pedal. The gearset housing forms the rear of the unit power plant casing and has on its underside two lugs cast integral with the aluminum case through which the king bolt of the third point of the support passes; these lugs are bronze metal lined to take the strain off the casing, which is of aluminum. There are three speeds with the ratios of 11.9:1 for low, 6.91:1 for intermediate and 3 1-2:1 for direct drive. The reverse has a ratio

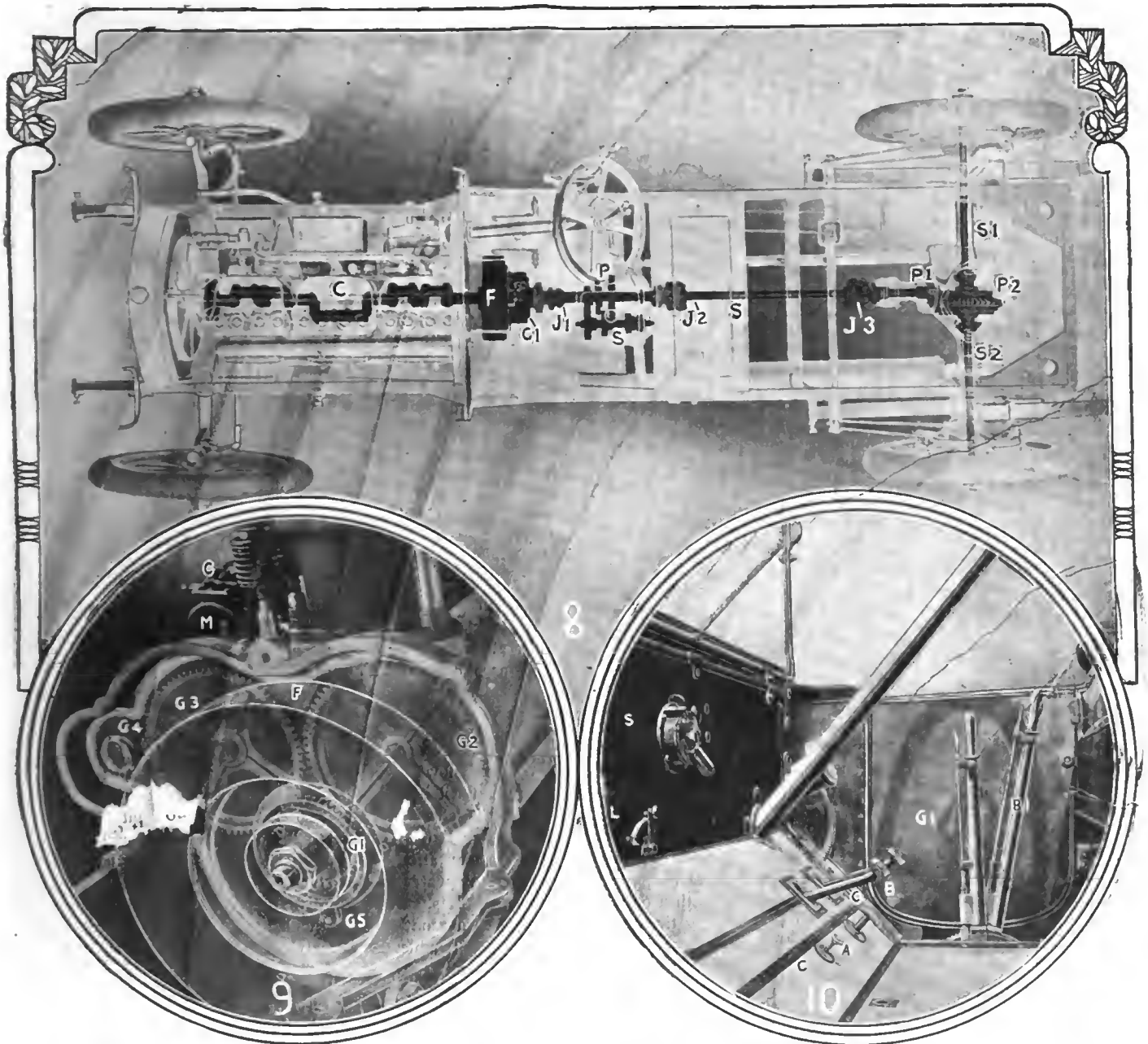

Fig. 8—Silhouette view of the Model AA chassis showing the shafting employed in the drive. Fig. 9—Rear view of the motor through the flywheel showing the timing gears and the magneto. Fig. 10—General view of the front compartment showing the dash fittings, pedals and levers

of 15.35:1. The method of taking the drive from the crankshaft through the clutch is shown in Fig. 8; the main shaft of the gearset P is squared to allow the gears to slide. Both primary and secondary shafts run on annular ball bearings, the forward and rear ends of the primary shaft being squared to accommodate the joints J1 and J2.

The escape of oil from bearing caps is prevented by the threads being made perfectly oiltight, and a series of return oil grooves where the shaft extends through. The gears are operated by a lever G1 shown in Fig. 10, working in a quadrant which has a series of ledges forming the stops for the respective gears. Neutral is between low and intermediate, the rising of the latch and forward movement of the lever positively registering the gears in intermediate or second gear; continuing forward without touching the latch engages the high speed or direct drive. The lower gears are engaged in the same manner, only the lever is moved toward the rear of car. As will be seen in Fig. 8, the propeller shaft is not encased, and the universal joints J2 and J3 are of the self-contained type. The cross contains a central lubricating compartment, supplying the four ground arms through a hole drilled centrally to their circum-

ference, while their surfaces are adequately lubricated by parallel ways.

Internally ground and integrally headed cup-shaped arms are pinned and held by nuts to cross arms on drive shaft of gearset, propeller and pinion shafts. By fitting these cups over the arms of central cross, a perfect universal motion results, while the centrifugal force as the joint rotates causes the grease to circulate over the entire bearing surface, under a slight pressure. Not one particle of the lubricant can be forced out as the inner lip of the four cups presses against the outer shoulder of the main cross. To insure the joint from any possibility of leakage, felt washers are placed in the recess where the cups and cross contact on their edges. The forward end of the drive shaft is square and telescopes the rear number of forward universal, a greaser being supplied at this point as well as at the central crosses.

The rear axle is of the full-floating type with a torsion rod T attached to the axle at one end in the bracket B, as shown in Fig. 5, and at the forward end terminating in a ball-socket bracket united to the cross member of the frame. The axle casing extends through and is fitted with a ball bearing on which the rear wheels run. The drive shafts can be removed from the

axle through the hubs and the outside extremities are fitted with a series of dogs which engage with corresponding recesses in the hub of the wheel. The carbureter C is removable and it is possible to withdraw the differential after the shafts have been drawn, by loosening the clamps that hold the ball bearings in position. The removal of the cover C1 permits of the withdrawal of the driving pinion and shaft which are forged integral.

Both hand and foot brakes are operated on brake drums 14 inches in diameter, bolted to each alternate spoke of the rear wheels. The brake shoes of the hand or emergency brake are of the internal-expansion type, whereas the foot or service brake contracts upon the outer face of the drum, and are lined with Raybestos. Adjustments are taken care of by accessibly situated thumb nuts, and the equalizing device E in Fig. 5 takes care of the service brake. The front wheels rotate on taper roller bearings, while the load on the upper end of the steering knuckle is carried on ball thrust bearings. The pins forming joints between the knuckles and the forks have the axes arranged vertically, but the stub axles slope slightly downward from the horizontal in order to give the wheels the requisite amount of play. The tie-bar coupling the steering arms is placed behind the front axle. The steering gear itself is of the worm-and-sector type, the worm being an integral part of the steering column, while the sector in the steering case is attached to the drag rod on a taper square. The steering gear is passing through the frame by means of two long bolts, and the drag rod is carried inside the frame ending in a ball-and-socket joint.

The frame is upswept at the forward end and offset over the rear axle, being pressed out of chrome-nickel steel, heat-treated, and the side members are held together by four cross-member gusset plates G and G1, being fitted for increased strength.

Semi-elliptic springs are used at the front, being 48 inches long, and the rear suspension is taken care of by three-quarter-elliptic springs. The springs are held in special clips with integral plate at the top, thus preventing drilling the springs.

Five open touring bodies, ranging in passenger capacity from four to seven, and three types of seven-passenger enclosed types are fitted to the standard Model AA chassis. The prices of the touring cars range from \$3,750 to \$3,900. Included in the equipment is a four-bow top, the side curtains and envelope and an adjustable glass windshield. All models are fitted with a 60-mile dial speedometer, four-cylinder air pump for inflating tires, side, tail and acetylene headlights, gas tank, shock absorbers for the rear axle and quick detachable rims.

## When Judgment Whispers Don't

- Don't mistake the silence of inactivity for silent performance.
- Don't pin your faith to every ancient proverb: one old saw has it that the wheel that turns gathers no rust.
- Don't rely too much on your chauffeur's eyesight just because he occasionally sees double.
- Don't forget that the bucolic Vidocq's idea of speed is apt to be exaggerated wherever an automobile is concerned.
- Don't go to extremes in automobile styles; in this age of rapid progress *passé* is just around the next corner.
- Don't knock the motor that knocks; the fault may be your own.
- Don't fail to remember that ill-mated parts must clash and that incompatibility of temperament is a legal ground for divorce.
- Don't allow an infected part to contaminate its neighbors; quarantine the car until the trouble is eradicated.
- Don't fail to scrutinize more closely than usual the credentials of the second-hand automobile that is painted in gay colors.
- Don't rely too much upon a 250-word guarantee; in the case of a stiff hill a good-performing motor is more to the point.
- Don't take liberties with a grade-crossing; play things safe—stop, look and listen.
- Don't forget that adagés, like dreams, frequently go by contraries; a horseshoe in some cases brings anything but luck to the automobilist.
- Don't allow the jejune narratives of the blatant salesman to act as blinders when on a still hunt for a good car.

**CONDENSER OFTEN MISPLACED**—The average motorist frequently places the acetylene gas condenser or its substitute in some position where it becomes caked with mud and is almost forgotten until it is full and the lamps begin to flicker. Then the mud is cleaned from it and it is drained out. It should be placed so that it is close to the lamps, where it will catch all of the condensation from the gas going to the burners, and in addition any water that may enter the burners due to washing of the car. It should be emptied from time to time, say once or even twice a month, when the lamps are in regular use. The majority of troubles with acetylene lamps are due to lack of a condenser and to the use of too small metal tubing.

## Looking for Something New

### Discussing Some Piston and Rotary Valve Motors

*In the present article it is proposed to show several ideas that have been developed along the rotary sleeve valve principle, together with a variety of piston valve motors, patents for which have been taken out in various countries. Steam valve practice has been resorted to in the case of the Lewis motor, and it is interesting to note, quite apart from the shape of the valves employed, the various methods employed in their operation.*

**I**N the piston-valve type of motors, some of which have already been discussed in previous issues together with those described in this article, specially formed cams are employed to obtain the combination of quick opening and closing and the necessary period of dwell during the compression and firing

strokes. If the time ever arrives when the majority of the motors of the valveless type that have been patented come to be used commercially, the question of prior right and infringement will present a knot that will be difficult to unravel.

#### The Lewis Slide-Valve Motor Follows Steam Engine Practice

The section of the motor shown at (BD) is the idea of Edmond W. Lewis, Coventry, England, and as far as the actual valve gear is concerned it is somewhat similar to the action of the slide valve used in steam engine practice. The slide valves A and C in Fig. BL consist of flat cast-iron plates about one-half inch in thickness, provided with slots B and D. The valve is caused to reciprocate through the action of the connecting rod F running at one-fourth speed of the crankshaft and driven therefrom by a suitable gearing.



The slow speed of operation should materially tend to reduce friction and permit of better lubrication. Each valve is provided with a balanced stationary valve seating. The valve seating or packing blocks S and S<sub>1</sub> are kept in continuous working contact by the pressure of eight small coil springs S<sub>2</sub>, S<sub>3</sub>, S<sub>4</sub> and S<sub>5</sub>, which are retained in position by recesses in the back face of the block. The covers H and H<sub>1</sub> are detachable and the sectional drawing shows the position of one of the sliding blocks during the exhaust stroke. The valves are lubricated under pressure at the points L and L<sub>1</sub>.

#### Marshall Rotary Disc Valve Motor of Simple Construction

Fig. BE shows two sections through the Dale Marshall motor. The section through the head of the cylinder shown at (B) shows the disc valve with a port hole P, which is caused to rotate and cover the intake and exhaust ports I and O. The valve plate V in (A) is connected by means of a pivot R at the periphery of the valve plate V to teeth, which are in mesh with a tooth wheel W situated in a recess S and driven by the vertical shaft A by oblique and eccentrically formed gearwheels D and E, which by reason of the eccentric movement of E transmit a variable movement to the shaft A and the valve plate V. This variable movement provides a reduction in the speed of the valve plate V when it is exposed to the compression and firing of the explosive mixture. The cylinder head is in the form of a cover secured by screws X, which facilitate the removal of the valve for inspection.

#### Von Lauerer Uses a Rotary Sleeve in the Cylinder Head

The method employed by Karl Cziharz Edler von Lauerer is applicable to any number of cylinders, and it will be seen from the accompanying illustration BF that the valve mechanism is placed directly in the head of the cylinders and communicating with them by means of a single port P<sub>1</sub>. Running on ball bearings is a sleeve S<sub>1</sub> driven from the crankshaft by means of a silent chain, to the pinion P<sub>2</sub>, which causes the sleeve to rotate. Within the sleeve there is a pipe B with suitable slots cut in it, so that as the chamber C<sub>2</sub> passes over the passageway P<sub>1</sub> the gases are admitted to the cylinder through the suction of the piston. Exhaust is carried away through the sleeve S<sub>1</sub>, the exit being through slots E. The intake manifold B, being placed as it is inside the sleeve S<sub>1</sub>, will cause the mixture to be previously expanded, but it is a question whether the expansion of the sleeve S<sub>1</sub> caused through the burning gases passing through it will not have a deleterious effect upon the clearance.

#### The Empress Motor Utilizes a Water-Cooled Rotary Valve of Simple Construction

The Empress engine shown in section in Fig. BG hails from the North of England. The valve V is driven by worm gearing from the crankshaft and runs at one-quarter speed of the latter. The motor is of the four-cycle type and has four cylinders cast en bloc approximately 4x5 inches bore and stroke. The cylinder head casting, which is water-jacketed at W and W<sub>1</sub>, is so formed that a water-jacketed and ported sleeve running the whole length of the block over the combustion chambers acts as a rotary valve. Suitable glands are provided for the water-jacketings. The intake and exhaust manifolds are respectively bolted to the cylinder casting by means of the clamp C and the nut B. The illustration shows the motor at the moment of induction.

#### The De Dion-Bouton Company Patents a Rotary Sleeve Motor

The engine is provided with two cylinders A (as shown in Fig. BH), surrounded by a water jacket A<sub>1</sub> common to both. The combustion end A<sub>2</sub> of each cylinder is reduced and the corresponding portion A<sub>3</sub> of the water jacket is similarly reduced. Around each reduced portion A<sub>3</sub> a rotary sleeve valve

B is mounted. Each sleeve is provided with teeth B<sub>1</sub>, which mesh together and receive motion from a gear wheel C that engages the teeth of one of the sleeves. Surrounding the sleeves is an outer casing D that fits the sleeves and also fits against the wall of the water jacket above and below the sleeves. The walls of the outer casing D are made hollow and are open at the end, as is also the water jacket A<sub>1</sub>, and these open ends are covered in by a plate E. This plate is provided with interior passages E<sub>1</sub> that communicate with the open ends of the water jacket A<sub>1</sub> and the hollow casing D, so that water can flow from the interior of one member to the other.

#### The Griffith Utilizes a Rotary Valve in the Shape of a Cone

As shown in Fig. BI, the valve stem V is rotated by bevel gearing, whilst the head is drawn on the seating by means of the spring B. The port is formed by the slot C, which is cut in the valve and in the plan section the relation of the slot C to the exhaust port D and the inlet port F is shown. There is a part of the cylinder wall shown at E between the intake and exhaust passage-ways which prevents any inter-communication between inlet and exhaust gases.

#### A German Invention Along the Lines of the Knight Valve

The sleeve valve shown in Fig. BJ needs little explanation, in view of what has already appeared in the recent issue of THE AUTOMOBILE concerning sleeve valve motors. The operations of the sleeves C and D are controlled by the eccentric B, which is placed over the heads of the cylinders, the sleeve C being operated by the connecting arm C<sub>1</sub> and the sleeve D by the connecting arms C<sub>2</sub> and C<sub>22</sub>. The invention was registered by the Deutsche Automobil-Konstruktions-Gesellschaft.

#### Small Motor Is of Rotary Valve Type

The four cylinders, D, E, F and G, of the Small motors, shown in Fig. BK, are arranged around the rotary valve. Two of these cylinders, D and E, are in the longitudinal central plane of the engine, whilst the other two cylinders, F and G, are inclined from opposite sides of the central plane towards the shaft axis. The pistons in the cylinders D and E are connected by means of rods with the pins A and C respectively, whilst the pistons in the cylinders F and G are connected by means of rods to the same crankpin B. The crankpins of the end throws are in line with one another and with the pin B of the remaining throw, which is set at an angle of 180 deg. relatively to the pins A and C.

The rotary plug type valve H has a central inlet passage J leading axially into one end and an outlet passage K leading from the opposite end. The inner ends of both these passages merge by easy curves into the required shape of their respective ports at the circumference of the plug upon which they bear, forming side by side the openings M and N, which are at the same level.

A partition separates the passages J and K, and the openings M and N are separated by a portion of the plug. The valve H operates vertically in a liner O, provided with ports P and R communicating with the cylinders D and E respectively. These ports are radial with respect to the valve H, the rotation of which puts each cylinder port in turn into connection at the proper times with the inlet and outlet passages J and K. The construction of the valve and liner is such that the valve can be drawn out of the liner endwise from the top of the engine, and the liner O is continued at its lower end to make a detachable union or other joint with an exhaust pipe S.

The parts are so arranged that upon disconnection of the exhaust pipe the liner O itself, together with the valve and ball race on which the rotary valve H works, may be withdrawn as a whole from the engine.

Within the liner O an inner circumferential gutter T is provided beneath the edge of the valve H. This gutter is intended to intercept any lubricant that may drain from be-



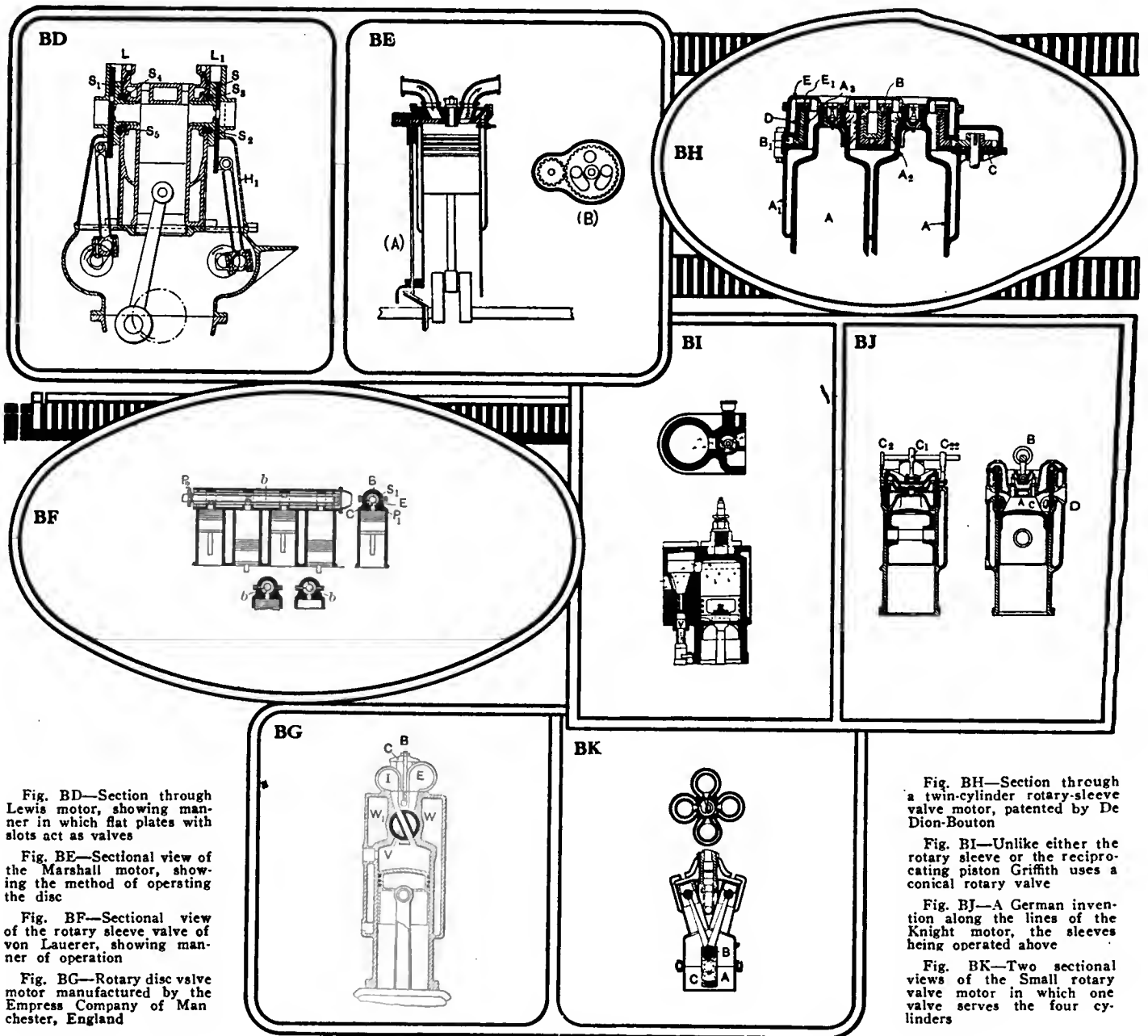

Fig. BD—Section through Lewis motor, showing manner in which flat plates with slots act as valves

Fig. BE—Sectional view of the Marshall motor, showing the method of operating the disc

Fig. BF—Sectional view of the rotary sleeve valve of von Lauerer, showing manner of operation

Fig. BG—Rotary disc valve motor manufactured by the Empress Company of Manchester, England

Fig. BH—Section through a twin-cylinder rotary-sleeve valve motor, patented by De Dion-Bouton

Fig. BI—Unlike either the rotary sleeve or the reciprocating piston Griffith uses a conical rotary valve

Fig. BJ—A German invention along the lines of the Knight motor, the sleeves being operated above

Fig. BK—Two sectional views of the Small rotary valve motor in which one valve serves the four cylinders

tween the plug and the liner, and the lubricant thus intercepted is conducted by a return pipe to the crank case. Between the valve and the inner circumference of the liner or valve seat, packings are provided, as shown. The valve H is rotated from the engine shaft by a bevel gear.

The cylinders F and G communicate with ports V and W respectively, and the valve H in its rotation successively establishes communication between the inlet J and each cylinder and between the outlet K and each cylinder in the manner shown in the illustration.

In view of the fact that all the cylinders are controlled by one valve, and since the valve itself cannot be modified to suit the angle between the axis of the cylinders F and G, and because the pistons operating in these cylinders on the same pin do not come simultaneously to the extreme of their strokes, it becomes necessary to compensate for the time lag between the pistons in the cylinders F and G; hence the ports V and W are set so as to have a certain amount of advance and lag. The requisite amount of advance and lag for opening and closing is obtained by raking the ports V and W to a greater or less extent instead of making them radial with respect to the valve H.

### Daimler Motoren Gesellschaft, Manufacturers of the Mercedes Car, Have Registered a Patent for Over-head Rotary Valve

Fig. BL illustrates the rotary sleeve patented by the Daimler Motoren Gesellschaft. Those who have worked on rotary sleeves will be interested in this construction, since hitherto the chief argument against this class of valveless motor has been the difficulty of keeping the sleeve tight. Following is an extract of the patent claim of the makers: The patent relates to a rotary sleeve valve for internal combustion engines, the sleeve space being partitioned by means of a wall, resulting in two spaces of varying cross-section, as shown in Fig. BC. The longitudinal partition is made of thinner or more elastic material than the sleeve itself, resulting in an expansion of the partition by the hot gases, whereas no expansion takes place on part of the sleeve. Another improvement is seen in Fig. (G) of the illustration, showing a wavy surface of the partition or one or more expansion grooves, taking up the expansion of the partition metal. Fig. (A) in BC shows a cross-section through the sleeve through the cylinder head, while Fig. (B) is a top view of the rotary sleeve, and Fig. (C) an end view. (D),

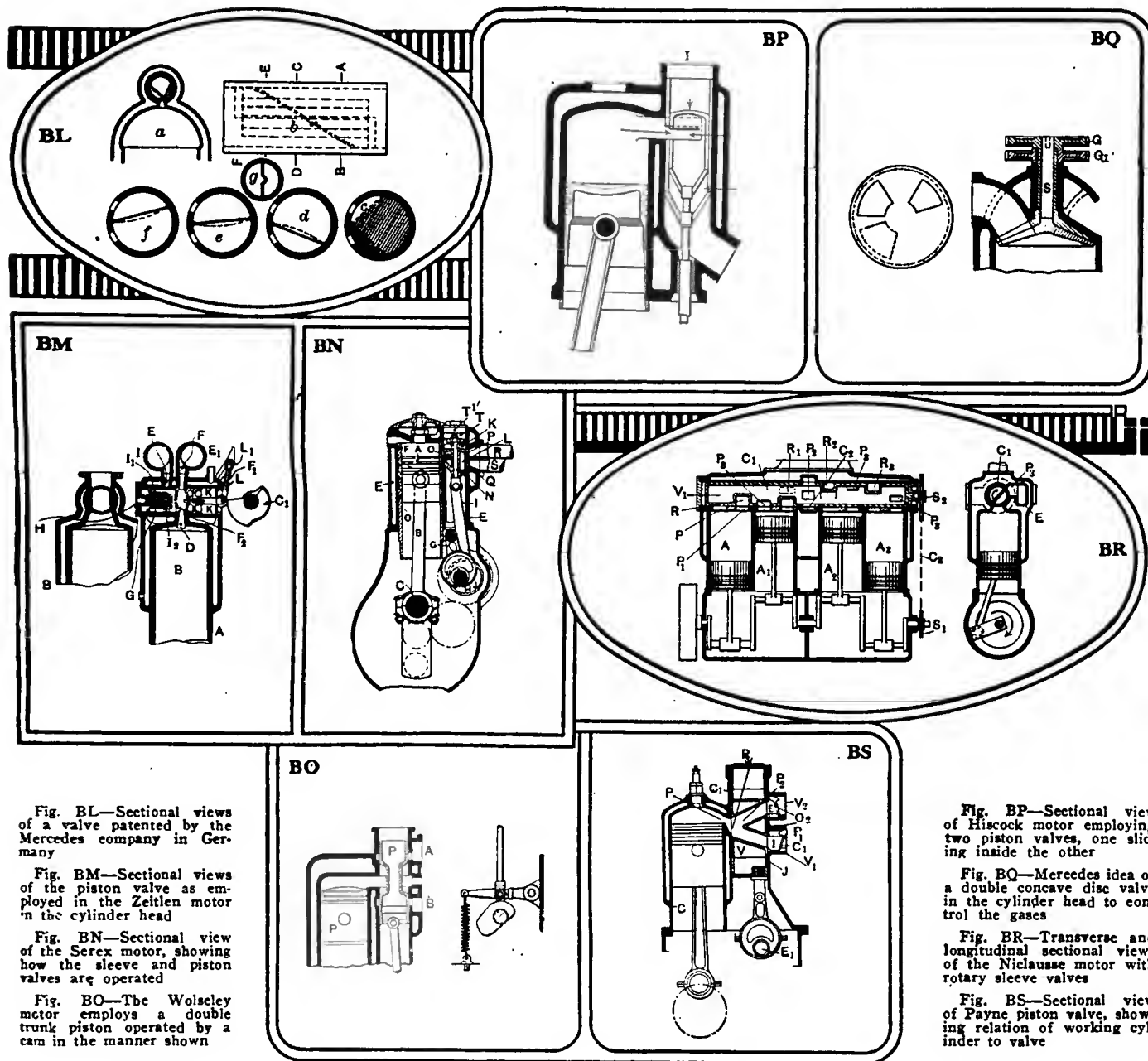

Fig. BL—Sectional views of a valve patented by the Mercedes company in Germany

Fig. BM—Sectional views of the piston valve as employed in the Zeitlen motor in the cylinder head

Fig. BN—Sectional view of the Serex motor, showing how the sleeve and piston valves are operated

Fig. BO—The Wolsley motor employs a double trunk piston operated by a cam in the manner shown

Fig. BP—Sectional view of Hiscock motor employing two piston valves, one sliding inside the other

Fig. BQ—Mercedes idea of a double concave disc valve in the cylinder head to control the gases

Fig. BR—Transverse and longitudinal sectional views of the Niclausse motor with rotary sleeve valves

Fig. BS—Sectional view of Payne piston valve, showing relation of working cylinder to valve

(E) and (F) are sections made through the lines AB, CD and EF, respectively, which are drawn in Fig. (B). In the sleeve 1 the partition 2 is provided, dividing the sleeve space in two longitudinal chambers, the shape of the partition being such as to make the chamber for the fresh gas increase in cross-section from the entrance side toward the other end, while the exhaust-gas space increases in the opposite direction. In Fig. (C) the cross-section of the inlet end of the sleeve is cross-hatched vertically, and horizontally at the other end. The partition 2, designed helicoidally to bring about this shaping of the two sleeve chambers, is much thinner than the sleeve itself.

**Zeitlen Motor Has Overhead Piston Valves**

This invention relates to the reciprocating piston valve for internal combustion engines, and of the kind which is spring-urged in one direction and shifted positively in the other by means of a cam or a layshaft. The hollow piston valve A, shown in Fig. BM, controlling the admission and exhaust of the working fluid to and from the cylinder B, is arranged to slide in a transverse valve casing, which is secured to or integral with the cylinder head being water-jacketed. There are three ports in the valve cylinder casing, the one at D leading into the

working cylinder and E and F in the opposite wall of the valve cylinder, E communicating with the intake manifold I, and F communicating with the exhaust manifold E1. The piston valve has two sets of ports in opposite walls, the induction ports I1 and I2 being adapted to register simultaneously with the ports E and D respectively, and the exhaust ports F1 and F2 with the ports F and D respectively. The compartment of the piston formed by the walls acts as a mixing chamber.

The spring G urges the piston valve towards the induction position, and is enclosed within and compressed between the pocketed end wall and the cover H, which has an air hole. The sectional view of A (BM) shows the valve in the position of exhaust by means of a cam C1, the contour of which is such as to allow the spring to force the valve in the opposite direction during the suction stroke and to hold it so that the ports in the cylinder are covered during the compression and firing strokes. The cam actuates the valve through the lever L fulcrumed at L1 and fitted with a roller co-operating with the cam, the piston valve being connected with the lever L by the link K, an adjustable stop being provided to regulate the closing.

### Serex Motor Utilizes Two Sleeves to Operate the Gas Ports

This motor, as shown in Fig. BN, has two sliding members, one co-axial with and outside the piston and having mainly for its object to ensure the gas tightness of the cylinder, and the other situated outside the cylinder serving as a distributing valve to place the cylinder in communication with the inlet or exhaust. The engine comprises a piston A acting through a connecting rod B upon a crankpin C. The piston moves in a cylindrical sleeve D reciprocating in the cylinder E. The sleeve D has no port and is provided at its upper end with a packing segment F. The sleeve D receives a reciprocating movement from an eccentric G mounted upon a shaft H driven by the crankshaft and turning at a speed half that of the latter and in the same direction. At the side of the cylinder E is arranged a smaller cylinder E1 in which moves a cylindrical slide valve I driven by a second eccentric J mounted upon the shaft H. This slide valve is provided with an annular recess K and an annular chamber L, in whose walls are formed two ports M and N. The cylinder E is provided with a port O and the cylinder E1 with two ports P and Q into which the admission pipe R and the exhaust pipe S lead. Above the valve I is a chamber T closed by a plug T1. The air enclosed in the chamber forms an air buffer and holds the slide against the eccentric.

### The Wolseley Motor Employs Sliding Piston Valve with a Cam That Allows Periods of Dwell

The cross-sectional view of the Wolseley motor shown in Fig. BO is similar in many ways to other motors of this type, which have been described previously. The piston P1 is placed inside a separate cylinder controlling the ports A and B and on the right-hand side of the illustration (BO) is shown the cam mechanism which causes the valve to reciprocate. It will be noticed that the shape of the cam is such that the valve stands substantially stationary in midway position when it is rapidly moved to its extreme position for the exhaust stroke, and next passes quickly across to the extreme position for the inlet stroke, after which it returns to the mid position for the compression and working strokes. The valve chamber extends above and below the inlet port of the cylinder and is provided in the upper portion with the inlet port A and the lower with the exhaust port B. There are no crossbars or other impediments in this type of construction to impede the flow of the gas or to become overheated through contact with the heated exhaust.

### Hiscock Uses Two Concentric Piston Valves Sliding One Inside the Other

The piston valve shown in Fig. BP is the invention of H. W. Hiscock and A. L. Reeves. The two pistons, A and B, reciprocate in the valve chamber placed parallel to the working cylinder. The valve A is closed at the top by a cap C, while the valve B is open at the top. Both valves have slots cut in them which register with the port E according to the cycle. When the inner valve C is lowered the gas can enter into the cylinder over the top of the cap, from the intake manifold which is attached at I. When the valve A, however, is raised in the position shown in the illustration the exhaust gas escapes through the two hollow valves and out through the passage-way F. In any intermediate position of the two valves the ports are closed.

### Mercedes Busy in the Patent Office With All Sorts of Valveless Motors

As long ago as November, 1909, the Mercedes company were granted a patent for a valveless engine as shown in Fig. BQ. The idea is very simple and needs little explanation. In the cylinder head of a motor operating on the four-cycle principle there are two concentric, concave discs, each attached at the upper extremity to gearwheels G and G1. The valve A is

attached to G1, and the valve B, whose spindle S passes through the hollow spindle of the valve A, is attached to the gear G by means of a key. Both valves are provided with ports and rotate in opposite directions and the port C is adapted to register with the inlet port D and the exhaust port E. The valves are rotated by an overhead shaft through suitable gearing. The application shown is one of several made at the time when the original patent was applied for. Whatever lubrication there may be for this type of valve is not shown in the patent application.

### Niclausse, the French Boiler Makers, Are Responsible for a Four-Cylinder Motor with a Single Rotary Valve

The section of the motor seen in (BR) shows the method employed by G. & A. Niclausse, of France, of controlling the intake and exhaust gases of a four-cylinder motor working on the four-cycle principle. The cylinders A, A1, A2, A3 are provided each with two ports in their heads shown at P and P1, which are controlled by the rotating valve V1, working in the chamber C1, which has a central annular chamber C2 communicating with the gas inlet pipe. Ports P2 are made in the portion of the valve V1 opposite to the annular chamber C2, which ports place the inside of the valve in communication with the chamber C2 and therefore with the admission. The valve V1 is provided with four ports P3 set at suitable angles to one another and adapted to the place opposite the opening P in the head of the cylinders in such a manner as to place the cylinders in communication with the gas admission. An exhaust pipe E in connection with the casing C1 by passage-ways, which lead into the pipe in planes corresponding to the exhaust ports P1. The valve V1 is provided in this plane with recesses R, R1, R2 and R3, set at angle to one another, which serve to place the heads of the cylinders in communication with the exhaust. The valve chamber is surrounded by a water-jacket, which is the continuation of that surrounding the cylinders. Valve V1 rotates at half speed of the crankshaft and is driven by means of a chain C3 from the sprocket S1 to the sprocket S2.

### Payne Piston Valve Offers Little Resistance to the Passage of the Gases

The gases in the Payne piston valve motor, a section of which is shown in Fig. BS, are controlled by a reciprocating cylindrical piston valve V which is parallel to the axis of the working cylinder C and adapted to be reciprocated with a gas-tight fit within a cylindrical valve chamber C1 cast on one side of the main cylinder C. The cylinder port P and inlet and exhaust ports I and E respectively open into the valve chamber C1, on opposite sides of the same, but not in the same plane. The valve V is provided with two ports P1 and P2 which converge toward one another, on the side adjacent to the cylinder port P and transversely through the cylindrical valve body.

The ports P and P1 in the valve may be arranged so that they unite in a common single port P3 on the side which control the cylindrical port P, while their opposite ends diverge and may be any distance apart. The arrangement is such that one of the ports P1 or P2 in the valve is open at its inner end to the cylinder port P during the compression and firing strokes, so that the valve proper is not subjected to any side pressure. The other end of the port would be covered and closed by the solid wall of the valve casing, which takes the pressure. The inlet and exhaust ports I and D, which are formed in the outer wall of the valve chamber, are provided with automatic non-return check valves C1 and C2, which may be furnished within and carried by the valve cases V1 and P2, thus preventing the exhaust gases being sucked into the cylinder during the suction stroke. The valve is caused to reciprocate by the eccentric E1 driven by the suitable gearing from the crankshaft and attached to a stud extension of the valve by an arm and a pin.

# Relation Between R. P. M. and Piston Speed

In the accompanying chart the inquiring motorist is afforded a ready means of ascertaining the speed of piston travel when the stroke of his engine and the number of revolutions per minute are known.

WITH the aid of the chart here shown (which was drawn by J. Dalrymple Bell, an English automobile engineer) it is possible to ascertain the piston speed of any engine in feet per second when the revolutions per minute and the stroke are known. It is also possible by means of this chart readily to find the stroke or revolutions per minute when the other factors are known. To ascertain the piston speed in feet per second, find the point formed by the cutting of the vertical line from the stroke (in inches or millimeters) and the radius corresponding to revolutions per minute. The feet per second of piston speed will then be found horizontally on the left of this point. As an example, if the stroke be 5 inches and the speed 2,000 revolutions per minute, the thick vertical line above the figure 5 on the lower scale must be followed until the diagonal line corresponding to 2,000 revolutions per minute is encountered. Reading then on the scale in a horizontal line to the left, it will be seen that the piston speed is exactly 28 feet per second or 1,680 feet per minute. As an aid to the use of this chart, a piece of black cotton may be passed through a small hole at the point of origin (the lower left-hand corner), and may be used instead of a straight-edge for those radii not drawn in, but the extremities of which are indicated on the top and right-hand margins.—*The Autocar*, July 15.

# It Stands to Reason—

- THAT the best roads are the scenes of the worst accidents.
- THAT carrying coals to Newcastle is a paying business as compared with the production of second-rate automobiles.
- THAT the noisy automobile is in the same class with the common scold—a nuisance to the neighborhood.
- THAT a scrobiculated cylinder will be all the better for a little grinding.
- THAT a quiet-performing motor is a sedative to the owner's mind.
- THAT in the building of good roads unless new methods are employed the remedy is worse than the disease.
- THAT the course of reasoning should be from the effect to the cause and then good roads will follow.
- THAT isolated stretches of good roads do not improve matters to any great extent.
- THAT an automobile is a boon only as it imparts at once pleasure and instruction.
- THAT the downward road is an easy one and the steeper it is the better it will show the hill-climbing qualities of the car coming back.
- THAT to err is human, but to forget the gasoline a second time is unpardonable.
- THAT it is better to have an oil gauge on the dash than to be worrying all day lest the pump be not working.
- THAT there is no sense in offering one's self up as a sacrifice just to prove that a railroad corporation is criminally negligent.
- THAT in negotiating a grade crossing it devolves upon the automobilist to exercise ordinary caution.

# To Remedy Clutch Troubles

This portion of an automobile's mechanism has a reputation for cantankerousness at times. A trio of its vagaries are here discussed, with suggestions as to how to remedy them.

THE average clutch has its vagaries; sometimes it may be just right; at others it may be slipping; again, it may be what is called "fierce." The second condition manifests itself in such pleasant situations as climbing a hill when, with the engine running at its highest speed and the proper gear engaged, the car starts to run backward instead of forward. Or on the level when, with the engine racing and the high gear in, no speed results.

The last condition shows itself in the sudden jumping forward of the car when the clutch has been let in, or it may even be so severe as to shear off the bevel driving gear when used with studded non-skid tires or any form that will not slip easily.

To repair the first, look at the leather; if this is all in good shape with an apparently good surface, but has lubricating oil on it, wash the surface well with gasoline. It is not a bad idea to roughen the surface of the leather a little with a coarse file.

The harsh or fierce clutch is remedied by the application of a proper oil for this purpose. Castor oil is universally used and a good way is to soak the complete clutch in it overnight. This will cure a case of harsh leather, but it may be that the trouble is only a lack of adjustment of spring tension. Usually there are an adjusting nut and a locking nut. Back off the latter and make an adjustment. Then tighten the lock nut to retain it. For the beginner it is better to adjust a little at a time and make several successive jobs of it than to try to do it all at once. But always adjust it as soon as possible.

POOR COMPRESSION NOTICEABLE AT LOW SPEEDS—Poor compression will not have as much effect on the motor at high speeds if the leakage is, as it is in most cases, small. Since there is such a short time which elapses between the compression and expansion strokes at high speeds the gas has a very small chance to leak out. At low speeds, however, the difference in power is very evident and the engine power falls off very rapidly at a time when it is most desired, as in hill climbing.

LUBRICATION ON HILLS—Sometimes it will be noticed that a motor will slow down on a hill where it has usually picked up. This is often due to over-lubrication of one or more of the cylinders, which will clog the muffler with soot and greatly increase the back pressure. If proper precautions are not taken, this will often occur where the oil flows about freely in the crankcase and runs down to one end when the car is tilted, as in going up or down hill.

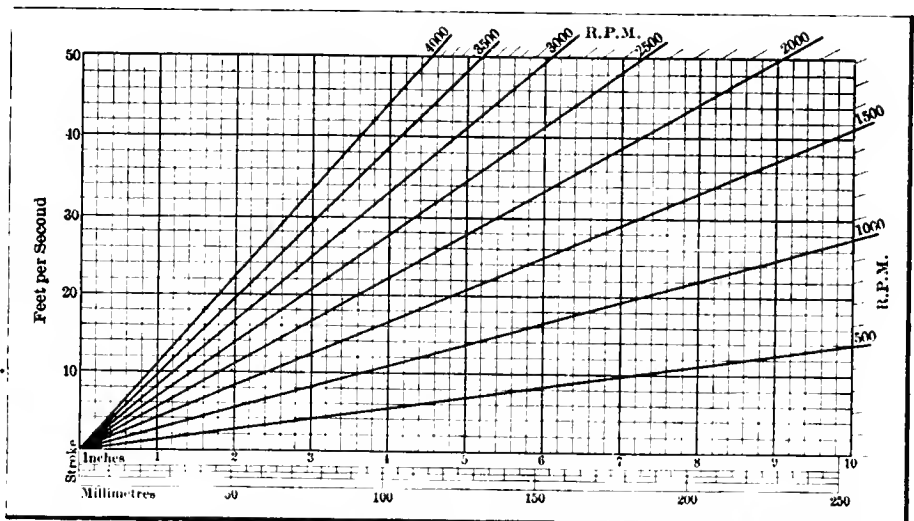

Chart affording a means of ascertaining speed of piston travel when stroke and R.P.M. are known

## Handy Way to Get Out of a Rut

Editor THE AUTOMOBILE:

[2,770]—The other day while out on a short tour in a part of Long Island that has evidently, and perhaps with reason, not been explored to any great extent, I found myself stuck fast in a rut. There is no excuse for the roads being in the condition in which I found this one, as it was almost impassable. I had a very hard time getting the car out of the position in which it had lodged itself, although I had a good rope along with me and in fact would not have got out as easily as I did if I had not had timely aid from an accidental country wagon. Could you through your columns give a method of procedure in a case of this kind, as I am sure it would be of general interest? R. T. C.

Long Beach, N. Y.

The matter of ruts is one that will crop up now and then in spite of our advanced stage of civilization and the vigor with which the good roads campaign is being pushed in New York State. There is a handy way of getting out if you are fortunate enough to have a rope along with the car and the rut happens to occur near a handy telegraph pole or tree. The accompanying cut (Fig. 1) depicts a method which was much used in the old days of the horse. A turn was taken about a convenient tree or post, then a smaller pole was placed in the position shown to act as a fulcrum for the lever pole. In this way quite a purchase can be obtained, and if the rut is not too deep and the car not too heavy so that the rope will not break the car can often be withdrawn.

## Flooded Carbureter Due to Punctured Float

Editor THE AUTOMOBILE:

[2,771]—After giving long and faithful service my carbureter has suddenly gone wrong. A steady stream of gasoline passes into the carbureter and if the drain valve is opened will flow from that. It refuses to work altogether and my car is useless to me until I repair it. Will you kindly tell me what the cause of my trouble would be liable to be and how to go about repairing the damage. R. T. CORRY.

Kingston, N. Y.

Examine the needle valve and see if it

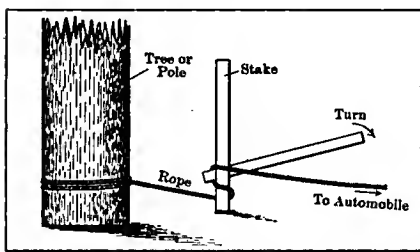

Fig. 1—Showing a handy way of withdrawing a car from a rut with materials gathered on the scene and a length of rope

## What Other Subscribers Have to Say

needs grinding down or if it has a particle of dirt (which has been taken in with the gasoline) stuck in the valve in such a position that it does not work properly. If this is not the case it will be found that the float is punctured and has filled with gasoline so that it has lost its buoyancy. Remove the float and shake it so as to detect if the gasoline has found its way in. If it has the problem of removing it will confront the operator. There are two ways of going about this. One way is to boil the float until all the gasoline therein has been vaporized and has found its way out. Another is to puncture it with another pinhole and blow it out. After the gasoline has been removed the float may be repaired with a drop of solder.

## Changing from Planetary to Selective Gear Is a Costly Undertaking

Editor THE AUTOMOBILE:

[2,772]—I have a 1909 16-horsepower toy tonneau. Would you be kind enough to give me some information telling me how I can install a selective sliding-gear transmission in place of the present planetary type, and also where I could purchase one that would suit my car? Could this car be rebuilt into a roadster type with a seat on the rear? LEROY E. WARREN.

Princeton, N. J.

You should not have any difficulty in turning the toy tonneau into a roadster in the manner you suggest, but the expense of installing a selective transmission will be prohibitive, the operation costing a good deal more than the new car. If you desire to have the work carried out, however, it would be well to consult some first-class repairman, who would no doubt give you an estimate.

## One Key as Strong as Two

Editor THE AUTOMOBILE:

[2,773]—Would you kindly tell me through your columns if there is any definite law in regard to the size of key-ways and if I should put two keys in a shaft would it not be stronger than one? I would greatly appreciate any information on this subject which you may be able to give me. I would also like to know the proper size key-way to use on a solid shaft 1 1/4 inches in diameter.

C. H. BUTLER.

Des Moines, Ia.

The size of the keyway is governed by a mathematical quantity known as the moment of inertia. Taking a section through the key-way as shown in Fig. 2, the relation of the key to the shaft will be seen. The moment of inertia of the cross sec-

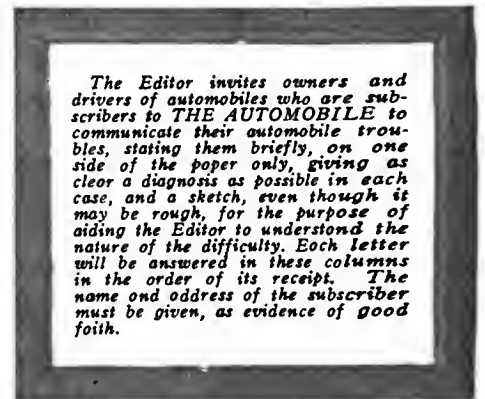

tional area of the key about the diameter of the shaft must be equal to the moment of inertia of the section of the shaft about the same axis. One key is as strong as two as long as this equation holds true. If there are more keyways than necessary

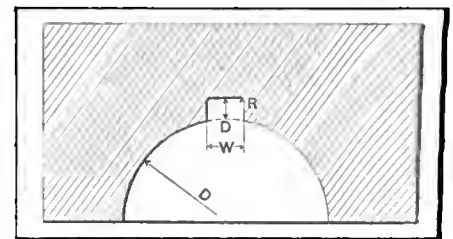

Fig 2—Illustrating position of keyway. D, diameter of hole; W, width of keyway; R, radius of curvature, and D, depth of keyway

the shaft will be weakened, since unnecessary material has been cut away. A 1 1/4-inch shaft requires a key in which W equals 3-16 of an inch, D equals 3-32 of an inch and R equals .04 referring to cut.

## Perhaps Some Reader Can Give the Information

Editor THE AUTOMOBILE:

[2,774]—Would you be so kind as to tell us who makes the rubber guard on the inside clincher tire to protect the valve stem from blowouts? It was patented April 9, 1904. The one we have is marked "2 E for 2 1-2, 3 and 3 1-2 inch rims only, No. 17." Any information would be appreciated. L. & J. A. STEWARD.

Rutland, Vt.

## Wants to Cut Oil Grooves in Connecting Rod Brass

Editor THE AUTOMOBILE:

[2,775]—I have noticed that on the newer models of the same make of car as the one I am driving the makers have connecting rod brasses which are slotted so as to have oil channels. What are the purposes of these oil channels? Are they of any ad-



# What Some Subscribers Want to Know

The Editor invites owners and drivers of automobiles who are subscribers to THE AUTOMOBILE to communicate their personal experiences for publication in these columns for the worthy purpose of aiding brother automobilists who may be in need of just the information that this process will afford. Communications should be brief, on one side of the paper only, and clearly put, including a rough sketch when it is possible to do so, and the name and address of the writer should be given as evidence of good faith.

vantage? If they are I would greatly appreciate any information you could give me on how to go about cutting these grooves.  
Hartford, Conn. E. F. G.

The purpose of the oil grooves in the connecting rod brass is to secure a more

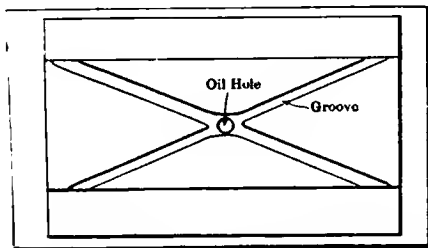

Fig. 3—Showing method of cutting oil grooves in connecting rod brass, grooves and oil hole being indicated

even distribution of oil than would be given by the oil hole generally placed in the bearing. The accompanying illustration, Fig. 3, will give an idea as to how these grooves should be placed. They are cut diagonally with a chisel and hammer, great care being taken not to raise a burr on the surface of the bearing. After having been cut in approximately with a hollow-edge chisel the groove is filed and finished with emery. The depth of the groove should be about 1-32 of an inch and should taper in depth to nothing at the point where the groove ends. The best method is to cut two diagonal grooves as shown in the cut, allowing them to intersect at the central oil hole.

## Does the Cut-out Assist the Motor at Low Speeds?

Editor THE AUTOMOBILE:  
[2,776]—Will you kindly answer, through the columns of THE AUTOMOBILE, a question which may be of interest to others besides the writer and I am sure will be appreciated if it helps to remedy the abuse of the muffler cut-out.

I notice that some drivers open the cut-out on every slight grade, even in a built-up portion of the city, much to the an-

noyance of residents of the street. Can you give me any definite information as to the increase of power obtained by opening the cut-out? From my experience in driving a car I believe that, with a properly designed muffler and driving at ordinary road speeds, say 500 to 800 revolutions per minute (with my car this means 15 to 25 miles per hour), there is practically none.  
H. J. FOSTER.

Scranton, Pa.  
The advantage gained by opening the muffler cut-out at the speeds you mention will not result in any appreciable gain in power; consequently, there is little utility in using it. The practice of opening the cut-out in cities or villages is one that should be put down with a strong hand by the authorities, as it brings motorists, as a class, into bad repute with the general public, and the whole body has to suffer for the sins against common decency committed by a few. Some people use the cut-out as a warning signal and this practice should be also stopped, since there are other equally effective and less objectionable signals in existence.

## Relative Positions of Armature to Connecting Rod

Editor THE AUTOMOBILE:  
[2,777]—As a subscriber to your magazine I take the liberty of asking some information on the correct relative armature positions when compared to the positions of the connecting rod and timer for dif-

ferent positions of the spark. That is, for a retarded or advanced spark. Can you enlighten me?  
M. F. B.

Atlanta, Ga.  
The relative positions of the piston and connecting rod to the armature and the contact-breaker can best be shown by means of a diagram. Such a diagram is given in Fig. 4. The direction of rotation is clockwise, and the maximum spark advance and retardation has been taken as 30 degrees. The position of the armature is so designed that the maximum current will be obtained under the greatest number of conditions of spark advance or retardation.

## Understands Everything Except the Reverse

Editor THE AUTOMOBILE:  
[2,778]—In a recent issue of THE AUTOMOBILE there was explained to some extent the workings of a planetary transmission, which was perfectly clear to me except that it did not tell just how the reverse gear worked.

Could you kindly explain, either by letter or through the columns of THE AUTOMOBILE, the action of the reverse gear? What I would like to know is just why and how the reverse gear works, as the rest of the transmission is clear and easy to understand.  
P. F. MINORK.

Overbrook, Pa.  
Generally, in reversing a planetary transmission, one of the gearcases is held by a constriction band. This will give a reverse motion to the annular gearing in the casing and hence drive the car in a reverse direction.

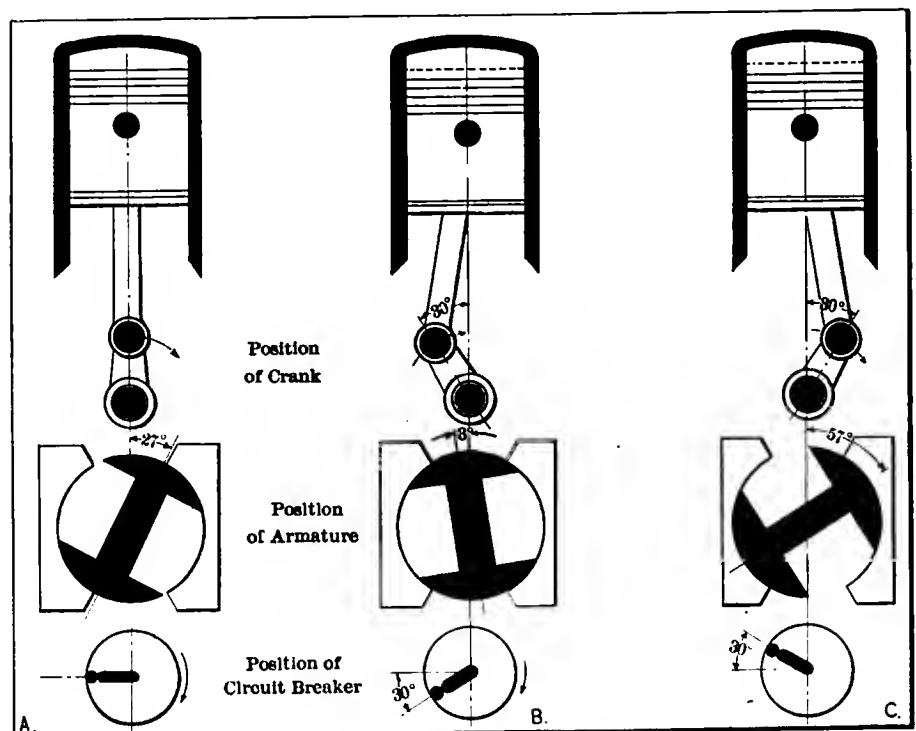

Fig. 4—Showing relative positions of crank, armature and circuit-breaker for greatest efficiency. A, Piston at top dead center; B, Position of maximum spark advance; C, Position of maximum spark retardation

## Meeting Recurring Troubles

### Presenting a Series of the Most Probable Cases

A series of correlated short stories, accompanied by diagrams and characteristic illustrations, including the nature of the troubles that are most likely to happen to automobiles, discussing their causes and effects, all for the purpose of arriving at a remedy. It is the aim for the most part to show how these troubles may be permanently remedied, and as a secondary enterprise it is indicated how the automobilist can make a temporary repair, thereby enabling him to defer the making of a permanent repair until a convenient time arrives.

**KEEP THE GARAGE FROM BUANING.**—Three or four racks full of fire extinguishers and hand grenades may be a most excellent equipment after the garage has started to add itself to the list of local conflagrations; but in this, as well as in most cases of the kind, an ounce of prevention is worth ten tons of cure. A small box of waste may go a long way toward being the proverbial ounce of prevention, and, if it is divided up into two parts like the one shown in the accompanying sketch, Fig. 1, proves, besides, a great boon to the garage owner. One part of the box can be used for soiled waste and the other part for clean.

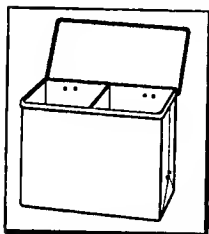

Fig. 1—Waste box divided in two parts to hold soiled and clean waste

A box of this sort may be stowed in a small place and indeed is better if it is kept off the floor at a convenient height, as in this way it will be fastened in one place and will not be kicked to the furthest confines of the building at a time when it does not happen to be required. The box does not have to be heavily built, but should be strong enough to be durable.

While speaking of boxes it may be well to mention the great utility of a series of pans in which to put all the fittings which will no doubt accumulate as time goes on. These pans may be of the type shown in the sketch, Fig. 2, and should be carefully classified with descriptive labels so that they attain the height of their usefulness. In repair work, where small parts need replacing, it will be surprising how many times the required part will be found to be in one of the pans.

**WHERE TO KEEP THE HOSE-RACK.**—The proper time, of course, to determine the position of the hose-rack is when the garage is being built, for once the water piping has been put into the building, or in some cases left out, it makes a very difficult matter of leading it to the desired place. The hose-rack should be in such a position that the hose can be used to the greatest advantage and therefore the position of the valve should be carefully determined. If the owner has such a place that he can wheel the car out of the garage and wash it down outside, the hose-rack and valve should be placed near the door and not at the rear of the garage. On the other hand, if the garage is in some place where the washing will have to be done inside, the car may be pushed to the back end of the garage, which should be equipped with adequate draining facilities, and the valve and rack placed so as to be convenient. In Fig. 3 is shown a hose-rack and valve in position and the method of supporting the rack. The hose is kept attached to the valve and the nozzle is always in position, so that the hose is ready for use at any time. The valve and two brackets are placed one above the other so that the hose will run free.



Fig. 2—Type of pan to be used in keeping miscellaneous fittings

It is of no advantage to have a hose longer than will be required, in fact it is a detriment, as all the hose will have to be unwound every time that it is used. Discretion should be used in buying the hose.

**A VERY HANDY TOOL.**—The adjustable spanner shown in Fig. 4, while a very handy tool, is not found in as general use as its great convenience and flexibility would seem to justify. It is very light and may be used for a variety of purposes. Its shape is such that there will be very few bolts or nuts on the car which will not be in reach with a tool of this nature.

If more circumspection were used in the purchase and equipment of the tool kit a great many useless tools could be eliminated and the weight and inconvenience of the equipment cut down. It is generally found in the garage as well as in the machine itself that after a time various instruments of different sorts that were purchased, perhaps, in a moment of misdirected enthusiasm or for some other reason, will collect. If tools of the nature of the adjustable spanner were kept the ever-growing list of impedimenta in the garage would be minimized.

**THE THERMO-SYPHON SYSTEM.**—With this type of cooling the recurring troubles are not very apt to be frequent or serious unless it is a case of gross neglect on the part of the owner or driver of the car. In Summer or Winter the system will perform its work if treated properly without any sign of a halt. The flow of water is entirely automatic and will, as a rule, be found to be very satisfactory if the pipes are sufficiently large. The accompanying cut will give a good diagrammatic idea of the system. In Fig. 5  $R_1$  is the reservoir,  $K$  is the radiator,  $C_2$  the water inlet to the cylinder jacket  $D_1$ ;  $C_1$  is the water outlet. As the temperature of the water in the cylinder jackets rises the water will commence to rise up into the water outlet pipe at the top. This water will naturally have to be replaced from the water inlet, setting up an automatic circulation which will be the more rapid as the cylinder heats up. The water in this system maintains a well-balanced temperature, well below boiling point.

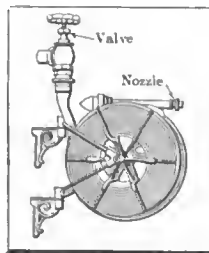

Fig. 3—Showing method of supporting hose-rack with position of valve and nozzle

**THE CORRECT WAY TO POUR GASOLINE.**—In pouring gasoline from a tank as well as in nearly every thing else there is a correct and an incorrect way to go about it. The correct way is accompanied by cleanliness as well as by speed and neatness. The accompanying cut, Fig. 6, shows the correct and the incorrect method of procedure. The left-hand part of the figure (A) shows the wrong way and the right-hand side (B) the right way. If the gasoline is poured so that the spout is just on a level with the top of the fluid the operator is able to regulate the flow at will, and when the tank is full he can stop immediately without spreading the gasoline over several square inches of unnecessary space. He can pour as rapidly or as slowly as he pleases because he can regulate the head of gasoline over the spout to suit himself. While pouring in the incorrect way as shown in the left-hand side of the same cut the spout is at an almost constant distance below the level of the liquid and the gasoline flow can not be regulated to any great extent. When the tank is filled it will be necessary to stop pouring at once and in this case it is very hard to do.

**PUTTING A LOCK NUT ON CORRECTLY.**—The lock nut, as shown in Fig. 7, is generally smaller than the nut whose office it is to hold the bolt to its work. The strains on the lock nut are not very great in any case, and for this reason it does not require so large a bearing surface on the threads. A bolt when brought into place with a powerful wrench compresses the metal which it bears against so that there is always a strain due to the elasticity of the metal, which impells it to regain its original shape. This longitudinal strain on the bolt

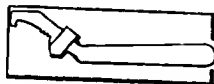

Fig. 4—Type of adjustable spanner which will be found to be a handy tool about the car

is all taken up by the threads of the bolt and by the threads of the nut which holds the bolt in place. Since this strain is ever present the jars and vibrations of the machine of which the bolt is a part take the rôle of a hammer which is giving a combination of an outward and lateral blow. The very blow that would be employed if it was desired to remove the nut with a hammer. To overcome this tendency a smaller nut is placed so as to lock the first nut into position.

When putting the lock nut on the bolt it should not be screwed directly down upon the first nut in the idea that it will stay there and lock it in place, as this is not the case, for the two nuts will then merely act as one large nut and come off together. The method to be pursued is different, being to first tighten the nut to be locked as much as possible, the lock nut is then brought down upon it and turned as far as it will go, whereupon the nut first tightened should be slightly turned back so as to bear against the lock nut. This method will set up reactions in metal surrounding the nut which will effectually counteract any tendency the nuts may have to jar off.

**GET A GOOD-SIZED TORCH.**—If you cherish any desires to do soldering work about the garage or, for that matter, at all, you will no doubt invest in some sort of torch in order to carry on the work. There are torches and torches, and the kind usually seen about the average garage are not exceptionally well suited for the work. The form of torch which should be bought will vary, of course, for the different kinds of work expected of it, but for the average garage equipment a torch such as is shown in the illustration, Fig. 8, will be the correct type to buy. For all-around purposes a tool should be designed so that it will be large enough to handle the most arduous duty to which it will be exposed, and it is for this reason that a torch of the design depicted in the accompanying illustration should be purchased when outfitting the garage or repair shop.

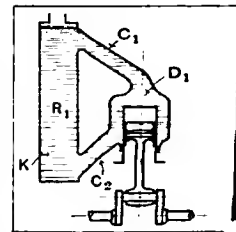

Fig. 5—Diagram of thermo-siphon system.  $R_1$ , reservoir.  $K$ , radiator.  $C_1$ , water outlet.  $C_2$ , water inlet.  $D_1$ , water jacket.

**INITIAL AND FINAL TEMPERATURES IN GASOLINE.**—An initial temperature of 60° F. will be sufficient for vaporization if the nozzle delivers a true spray. This will give a final mixture temperature which is considerably below the freezing point of water, and will thus cause a drying of the air through a condensation of the water vapor present. With perfect spraying and initial temperatures at 60° F., vaporization is still far from instantaneous, and cannot be completed within the carburetor itself.

A temperature as low as 32° F. would not be attained by the mixture within the carburetor and lower manifold, but would begin to be approximated only toward the upper parts of the manifold. The heat conducted from the cylinders by the passage walls is sufficient to obviate a mixture temperature of 32° F. even during the latter part of the vaporization, which takes place quite close to the cylinders. With initial temperatures at 60°, a temperature of 34.5° F. has been observed in a perfectly vaporized mixture just before its entrance to the valve pocket. This seems to show that the heat of the manifold walls entered into the action toward its latter part, and prevented freezing of water vapor while at the same time assisting vaporization. The engine was running at about 950 feet per minute piston speed at full load.

The lowest initial temperatures are determined by the fineness of fuel division, which is determined by several conditions, as mentioned above. If the division is imperfect, a greater heat supply will be needed in order that the vaporization may be complete within the limited time available, but the greater the heat supply the hotter will be the mixture and the greater the power losses.

In the vaporization of fuel in spraying carburetors it is often found that no air temperature up to 120° F. is efficacious in bringing about complete vaporization within the allowable time. Where the fineness of delivery has been progressively increased to a possible maximum value it has been found feasible to form a mixture of perfectly vaporized gasoline and air with an initial temperature of 58 deg. F.

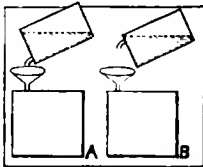

Fig. 6—Correct and incorrect ways to pour gasoline. A, incorrect; B, correct.

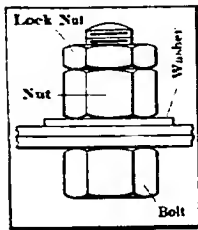

Fig. 7—Showing lock nut in position on bolt

In a typical spraying carbureter the method of application of heat for vaporization for best results will depend upon the character of the fuel spray, as well as upon the construction of the mixing chamber of the carbureter and the form of the manifold passages. If the division at the nozzle is fairly fine, the application of additional heat as an increased initial air temperature will, in general, be of the greater value.

This is more particularly true if the carbureter and manifold passages are free from bends. If the passages are tortuous, a heating of the walls will assist vaporization with a less expenditure of heat, and will give an equally good mixture with a lower resultant temperature than will a heated air supply. If the nozzle delivery is very poor as regards division, heated walls will serve best.

The whole question as to which of the two methods is best for any specific case resolves itself into another question—with what is the liquid chiefly in contact after it leaves the nozzle? If the nozzle so divides it that it remains chiefly entrained in the air column, a heating of the air will give the best results; if the division is coarse, the liquid will be spread over the walls, and a heating of the walls will then be the better method, subject to the same condition of proper temperature maintenance. The extent to which fuel division is carried at the nozzle determines the temperature at which the mixture can be formed for any degree of vaporization.

**TYPES OF ELECTRIC GENERATORS.**—The magneto generator, besides being the first type of electric generator in use, is the simplest as well as the cheapest mechanical generator. Since, for the power provided, this machine is the heaviest and most bulky, it is only in use for light work, such as ignition, bell-ringing and other light requirements. As shown in Fig. 9, the magnetic field is permanent, the poles being indicated by the letters N and S, standing for the north and south poles respectively. The magnets are very heavy and large, and it is for this reason that the magneto-machine can not be used in the larger kinds of work for which an electric generator is required. The duty imposed by the electric ignition of an automobile engine, while continuous, is not heavy. The continuity renders battery ignition undesirable on account of the exhaustion of the batteries after a comparatively short time of service, although at first there is no more desirable form of ignition than that obtained from the use of batteries on automobile or motor-boat. The magneto meets the requirements of ignition perfectly, as it has the two good features of simplicity and constancy. For this reason it is very reliable, and magneto trouble has been reduced to a minimum. Any ignition trouble is much more liable to be in some other part of the circuit than in the magneto. If anything does go wrong with the magneto it is best that an electrician be allowed to do the repairing.

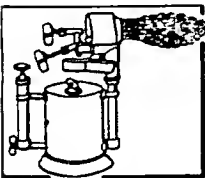

Fig. 8—Illustrating the proper kind of torch to meet the test of average service

THE SEPARATELY EXCITED GENERATOR.—The requirements of an electric generator to meet the vicissitudes of larger work than that to which the magneto machine is generally adaptable are met by the separately excited generator. In this type of generator the field magnets are excited by means of a coil fed from some source of electrical energy other than the current from the generator itself. This type of generator possesses all the qualities of the magneto without the disadvantage of the great weight and bulk of the latter relative to the electromotive power produced. It requires, however, a separate source of current for excitation purposes only and it is for this reason that the method is not employed more extensively; as it would require an auxiliary machine or battery, therefore, the system is not used except where there are many machines in action and in cases where the terminal voltage exceeds about 800 volts. The greatest use for this type of electric generator is in exciting the magnetic field of alternating-current generators since a steady magnetic field can not be produced by an alternating current. Fig. 10 gives a diagram of this type.

In this machine as in the magneto the electromotive force may be governed in three ways: By altering the speed of rotation of the armature, by varying the number of conductors by remov-

ing some of the brushes, and by changing the magnetic flux through the armature. The latter is done in the case of the magneto machines by shunting the flux away from the armature by means of an auxiliary piece of iron. In the self-exciting generator the magnetic flux is varied by changing the number of turns in the solenoid or exciting coil, or by regulating the strength of the exciting current. Continuous current generators may be made self-exciting by several methods.

The remaining types of generators are shown diagrammatically in Figs. 11, 12 and 13. The series continuous-current generator has the great disadvantage, as it does not start to generate until a certain speed of rotation has been reached that it is also liable to become reversed in polarity. The greatest use of series-wound generators is to supply arc lamps in aeriea. The shunt dynamo sends a small part of the current from the armature through the field winding. When properly designed the machine is self-regulating at mean loads. When overloaded the electromotive force soon reduces itself to zero. The separate-circuit, self-exciting generator supplies the field circuit by part of the armature or by a separate winding on the armature as shown in the illustration. It is much like the separately excited generator.

**LATENT HEAT OF VAPORIZATION OF GASOLINE.**

The specific heat or amount of heat measured in B.T.U. (British Thermal Units) necessary to raise 1 lb. of gasoline 1° F. is .500. Hence a drop of 1° F. in the temperature of 1 lb. of gasoline corresponds to the dissipation of .5 B.T.U. The specific heat of air at constant pressure is .2375; and a drop of 1° F. is attended by the dissipation of .2375 B.T.U. per lb. of air. Taking the mixture proportions as 1 : 15.39, as above, the heat available per ° F. of drop in the temperature of the mixture is  $1 \times .500 + 15.39 \times .2375 = 4.155$  B.T.U.

Since the latent heat of vaporization is very approximately 210.5 B.T.U., it follows that this 210.5 B.T.U. must be supplied by the ingredients or by heat from some outside source applied directly to the fuel.

Consider the heat supply in the mixture ingredients themselves. Since the mixture 1 : 15.39 is capable of supplying 4.155 B.T.U. per ° F. of drop, it will require a drop of  $\frac{210.5}{4.155} = 50.66^\circ$  F.

in the mixture to completely vaporize the 1 lb. of fuel contained therein. The mixture 1 : 15.39 cannot exist below 1.5° F., so it will be necessary that both the air and the gasoline have a temperature of at least  $1.5^\circ + 50.66^\circ = 52.16^\circ$  F. before the commencement of vaporization. If the mixture is 1 : 18, it can exist at  $-5.8^\circ$  F., and the initial temperature of the ingredients must be at least 38.3° F.

If the requisite amounts of fuel and air are placed in a vessel insulated from outside heat, the above initial temperature values will hold only when the time allowance for vaporization is unlimited. Compared with the short time in which vaporization must be completed in an automobile engine, the passage of time before vaporization would be completed would be almost infinity. However, there are three methods whereby the rate of vaporization may be accelerated; either the fuel may be introduced in a finely divided form; or the initial temperatures of the mixture may be made higher than the above values; or a combination of both methods may be employed.

In any case, the temperature drop can be no more than 45° F. in any mixture of gasoline and air. Therefore, if an increase in initial temperature is resorted to, the final temperature will be higher than that necessary to support the mixture proportions by just the amount that the initial temperature is raised. Suppose an initial temperature of 100° F. and a drop of 45° F. The resulting final temperature in the mixture will be 55° F.

In consideration of the form in which the fuel is presented to the air in the average carbureter, this final temperature will be higher than 55° F. because the total amount of fuel will not have been vaporized, and the amount of heat necessary to complete the

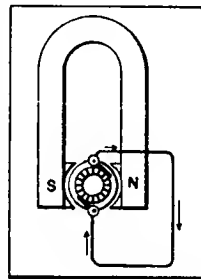

Fig. 9—Diagrammatic representation of a magneto-generator

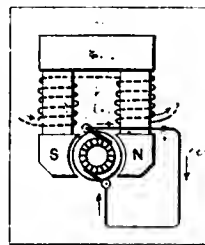

Fig. 10—Showing diagram of a separately excited generator

vaporization will remain in the mixture as a temperature value. But suppose the vaporization to have been completed in two cases with the final temperature of 55° F. in one and 1.5° F. in the other. Since the same amount of fuel is present, the volumes per lb. of the two mixtures, at the same pressures, may be taken as bearing the same relationship to each other as the volumes per lb. of dry air at equal pressures and the two temperatures given. Thus, the ratio of volumes per lb. of mixture may be expressed 1 : .88, for the two mixture temperatures of 1.5° and 55° F. respectively. Therefore an engine can aspirate only .88 the amount by weight of 55° F. mixture that can be aspirated of the 1.5° F. mixture. Loss in weight of charge will be greater than here indicated, since the efficiency of the pumping strokes will vary with density of the fluid.

The power of an engine varies as the weight of charge, being greater with a lower mixture temperature.

**FUEL ECONOMY IN HIGH VELOCITIES.**—The fuel economy resulting from the use of air velocities higher than the average, and thus lower pressures, is quite marked. Of course, with high charge velocities, the maximum power is not realized above a certain piston speed; but the fuel economy and efficiency will be greater within the range which the high velocity device can supply without too great a loss per cylinder charge. This latter fact is easily demonstrated by making two series of runs with any multiple-cylinder automobile engine. One series should be made with carbureter and manifold passages of such areas that an average charge velocity of about 8,000 feet per minute is had at a piston speed of 1,000 feet per minute, and the other series with passages which will give the above charge velocity at between 600 and 700 feet per minute piston speed.

A comparison of the two series of runs will show that up to that piston speed at which the volumetric efficiency of the engine pumping strokes falls off because of too high a charge velocity the power deliveries are approximately equal, the fuel consumption per brake horse power hour and the thermal efficiency have each been improved. The passages giving the above charge velocity at the higher piston speeds will permit of the development of a greater power at those speeds, and are thus superior from the viewpoints of maximum economy and efficiency at maximum output, which is the condition desired.

The points which it is desired to bring out are: That the greater the pressure drop in the passages the more perfect will be the breaking up of the fuel, the more rapid will be the agitation and internal motion in the mixture column, the greater will be the vaporization due to pressure reduction; and, as a final result, the fuel will be more thoroughly vaporized, and the mixture more homogeneous. There are in present practice several examples of the above utilization of high air velocities and low pressure in the carbureter passages through several spraying nozzles, each located in a separate, small passage. These are put into communication with the manifold in a progressive manner in accordance with the engine demand; and thus practically constant, high air velocities and low pressures are maintained, no matter how many or how few are serving the engine.

The advantages possessed by such a device for the vaporization of the fuel are apparent, though it appears that these devices were primarily designed with a view to securing a more automatic proportioning of the mixture.

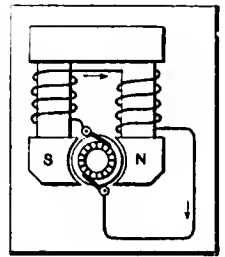

Fig. 11—Illustrating a series-wound continuous-current generator

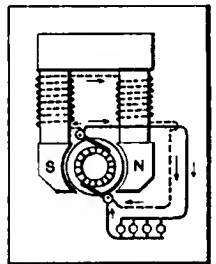

Fig. 12—Representation of a shunt-wound generator

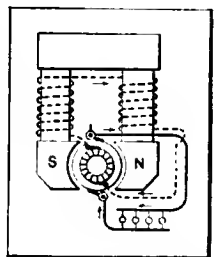

Fig. 13—Diagram of a separate-circuit, self-exciting generator

# Modern Automobile Factory Practice

## Electric Drive the Trend in the Newer Plants

*The problems peculiar to the manufacture of automobiles are met in at least a representative number of large plants by the electrically driven machines which combine the advantages of flexibility and low first cost with that of insurance against heavy financial loss in off years. The product of the General Electric Company is used to illustrate some of the points.*

THE manufacture of automobiles on a large scale is conducted under conditions which are peculiar to the automobile industry rather than typical of modern machine shop practice. A large percentage of all the cars purchased are pleasure vehicles, hence they represent the idle capital in the country which is directly dependent upon the prosperity of the times. It is evidently impossible to predict therefore the probable demand for any appreciable time in advance. For this reason the factory apparatus has been designed in a large majority of cases to give the maximum flexibility with a minimum investment. Or the factory must be able to meet the greatest demands which will be laid upon it as well as not to suffer financial loss during an off year.

Where electric drive is used, for the most part, the rates are low for the power used during the ordinary working day, and the consumers are thus saved the large and somewhat risky investment of expensive generating equipment. There are, however, several isolated automobile plants in various parts of the country a small percentage of which are using direct current apparatus, although in general alternating current is employed. This is the most satisfactory source of power, since the factory is able to use polyphase induction motors and to take advantage of the reliable and simple features of construction which are peculiar to these types of motors.

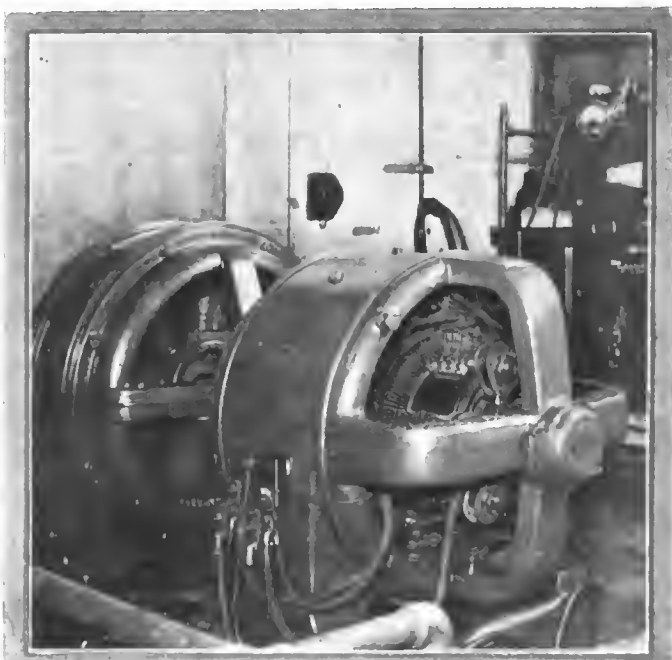

Fig. 1—Synchronous motor generator set consisting of 900-250-volt generator and 900-220-volt synchronous motor

In one of the largest groups of automobile manufacturing buildings in the United States the electric power is supplied from a steam generating station having a capacity of 7,000 kilowatts. The generating units consist of two Curtis turbine alternating current, three-phase, 60-cycle, 5,000-volt generators, one of the vertical and the other of the horizontal type. Energy is transmitted at the generator potential to the plants by an underground conduit system composed of five three-phase lead-covered cables insulated for 24,000 volts, each cable having a normal capacity of 2,500 kilowatts. The conduit system is arranged to receive additional cables as they may be required. In addition to the load imposed by the automobile plant, the power station supplies light to a city of 40,000 population.

The largest plant in this group employs about 9,000 men and turns out 180 complete cars per day. The electrical distributing system of this concern consists of nine step-down transformers for reducing the potentiality of the incoming current from 5,000 volts to the working voltage of the motors and the lighting circuits. The motors are operated from three-phase, 440-volt mains,

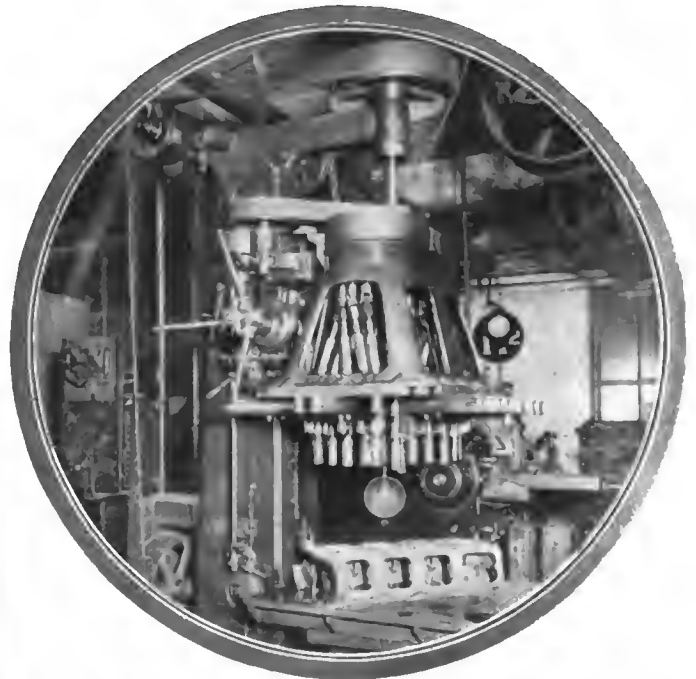

Fig. 2—Type of multiple-spindle drill generally employed for motor castings

while the lighting is supplied from single-phase, three-wire, 110-220-volt mains.

The transformer stations are completely equipped with control and distributing apparatus, including large oil-break switches for high- and low-tension currents, tubular busbars of seamless copper and all protective devices. The transformer capacity totals 6,375 kilowatts for power and 1,650 kilowatts for the lighting circuits. Fifty-two oil-break switches ranging in capacity from 500 to 2,000 amperes are employed. Energy is distributed through the building in iron pipe conduits.

The factory machinery will be found in most cases to be suitable for constant speed drive, and the squirrel-cage type of induction motor will be suitable. In the above-mentioned factory this type of motor was made standard and was mounted in bays



in the single-story buildings, while in buildings of more than one story they were suspended from the ceiling. One hundred and eight-five motors ranging in size from 5 to 100 horsepower capacity are installed; the 25, 35 and 50-horsepower sizes predominate, however, and a large number of motors of this size kept on hand enables the electric department to make rapid changes on short notice in case of a breakdown or change in the load requirements. Frequent tests should be made on all the motors so as to keep the load on each as nearly normal as possible.

The sheet metal working departments require large form-presses which will be operated by electric motors of 35 horsepower. In the factory described these motors are mounted in the bay, similar to the manner described for the group drive. The

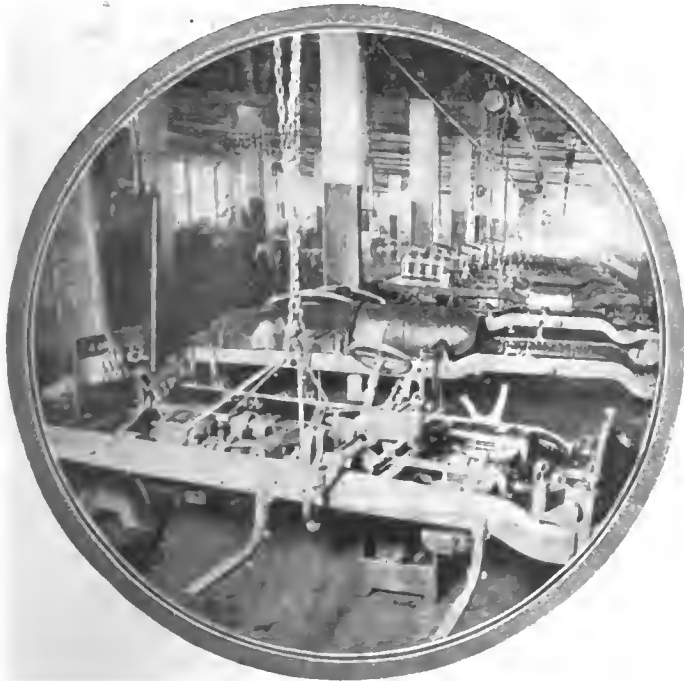

Fig. 3—Milling machine driven by 1-2-horsepower, 1200-220 volt, induction motor

electro-plating department in this factory is equipped with two generating sets supplying current for this purpose. Each of these consists of a 35-horsepower motor driving a 24-kilowatt low-voltage generator by means of a chain belt. Large copper busses carry the current to the electro-plating vats.

In the building of the engine the work is done to the greatest advantage when all of it is concentrated in one building. The machinery required would be all the necessary apparatus for the machining, assembling and preliminary trials on the engines. In the above factory this department is supplied with twenty-two 35-horsepower, three 25-horsepower and five smaller motors, each, in most cases, driving a separate tool, as shown in Fig. 2. In the forging department both steam and electricity are used; steam for some of the larger hammers, while the smaller hammers, shears, presses, blowers and air compressors are operated by electricity. The assembly and body building departments do not require much power equipment, as a large part of the work is of necessity done by hand.

It has been the experience of the larger companies that where a concern could predict accurately the output, they are gradually putting a separate motor on each machine (Figs. 3 and 4). The frames and motors in this case are made interchangeable and several advantages are claimed for this system.

**REMOVING TIGHT VALVE CAPS.**—When the valve caps stubbornly resist all efforts to remove them from their positions, try running the engines until they are warm and then put cold water in each cap. The cap will contract sufficiently to loosen.

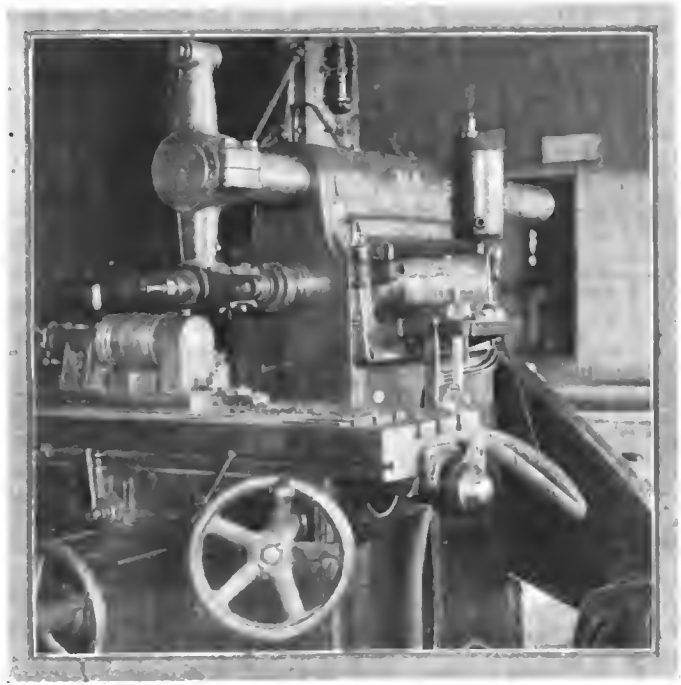

Fig. 4—1-horsepower, 1800-220-volt motor driving portable miller on assembly floor

## The Automobile Opens New Territory

*Many beautiful but inaccessible spots along the shores of rivers, sound and ocean, as well as in the mountains, which were, until recent years, almost unknown except to an occasional straggler, have now developed into convenient and ideal locations for country homes.*

THE automobile has done much in the way of building up outlying districts in the small towns where trolleys are not paying propositions and which have been clustered around the railway station, but it has of late years gone a step further and has been the means of opening up for summer homes, spots where the beauties of nature are unspoiled by frequent traffic. There are many places where the inhabitable sections must be reached from the depot by means of a stage or some sort of rig driven and owned by people who are entirely independent of the livery business as a means of livelihood and therefore not apt to worry very much if a morning call or two are neglected because the horses are needed out in the fields.

The automobile owner is not troubled in this manner and does not have to gauge the distance he lives away from the depot by his sprinting ability when he hears the whistle of the approaching train. Instead he is able to pick out the most favored spot in building his summer home and the real estate will cost him less because he is further from the noisy trains.

**SMOKE IN THE SIGHT FEED**—If the glass becomes opaque through the backing up of smoke from the crankcase a good method of prevention is to make a U-bend in the oil pipes at some point in their length where they are horizontal, if possible. This will form what is known by plumbers as a trap, and while making no difference to the flow of oil will effectually check the passage of smoke from the crankcase to the sight feed.

**ENGINE APPEARS TO LOSE POWER**—If an engine appears to lose power without reason apparently, and nothing can be found which is wrong in the working parts of the engine, it may be that the brakes are on when they are supposed to be off. There is a rather inaccessible adjustment on some brake couplings which is likely to work loose, and lengthen the connections so that the brakes may be on at either end of the brake-lever quadrant.



# A New Type of Valveless Motor

## Describing a Method of Complete Exhaust Scavenging

*Two problems that are ever before the minds of designers of internal combustion motors have been combined in one motor by a Belgian named Cottin, and the description of which appeared in La Vie-Automobile. The valveless theory part seems to have been well thought out, and the hemispherical shape of the combustion chamber does away with all pocketing.*

VALVELESS motors are becoming modish; there is nothing surprising about this, as inventors are working over-time on the subject. Why is it that the janitor, grocer, ironmonger and the doctor rack their brains to invent a valveless motor? Do they really think that it is such a simple matter as giving warning of a protest, weighing 2 cents' worth of mustard or nails, or making their fellow-beings swallow, through publicity, pills specially concocted for pale people?

To obtain perfect running is a problem considerably more complex than the majority of inventors opine.

The most important points to be considered in designing motors in general and valveless in particular are:

1. Lubrication.
2. Gastightness, and
3. Expansion.

These three points are precisely the ones that remain in the background when an endeavor is made to solve the problem on paper.

In describing the Cottin motor a certain peculiarity is presented which raises one of the most interesting problems in the construction of motors.

### It Is Possible in the Cottin Motor to Effect a Complete Scavenging of the Burned Gases

It is a well-known fact, that, in the ordinary motor, the compression chamber remains filled at the end of the stroke with dead or burned gases which have a pressure in the neighborhood of the atmospheric.

These dead gases mix with the new gases that are sucked in on the intake stroke. They dilute the fresh gas and heat it.

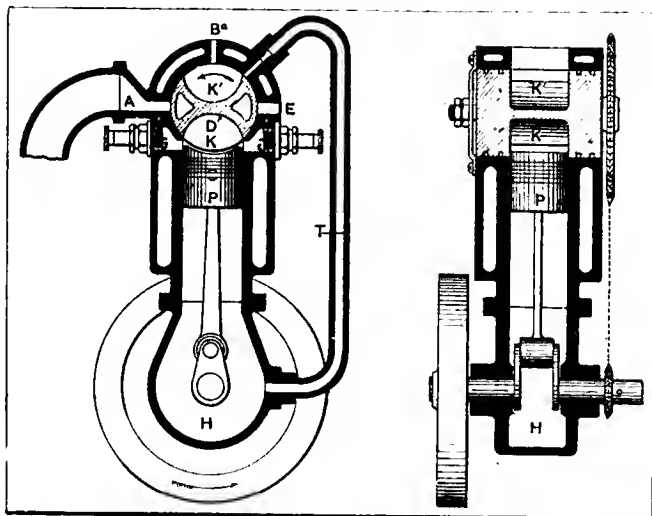

Fig. 1—Sectional views through the Cottin motor, showing the shape of the rotary valve and the method of driving the valve by means of silent chain

From the thermodynamic point of view they are injurious, as they diminish the weight of the intake charge.

In a motor with 5 kilogrammes of cold compression equal to about 70 pounds per square inch, for example, the compression chamber has a volume equal to one-quarter of the piston displacement. If this space were to be filled either with fresh gas or pure air instead of dead or burned gases, the weight of the total cylinder volume will be increased about 25 per cent. and it is to be confidently expected that the motive power will increase in an equal proportion. One would imagine that the scavenging motor will heat less than the motor that is not scavenged. It is a known fact that the calories that find their way through the cylinder walls of the motor are in a large degree occasioned by the burned gases that remain in the cylinder during the exhaust stroke, and in the compression chamber during a great part of the admission stroke.

Take away these heated gases which are in the neighborhood of 300 to 400 degrees Centigrade (570 to 750 Fahrenheit) from the compression chamber and replace them with fresh air of a temperature of about 15 to 20 degrees Centigrade (59 to 68 Fahrenheit) and the heating of the motor will be diminished in a large degree.

### How Is It Possible to Produce this Scavenging Effect in a Four-Cycle Motor?

It is a simple matter to produce it in two-cycle motors. The Cottin motor offers a solution and is composed essentially of a cylinder and a distributor situated in the head of the motor. The distributor D shown in Fig. 1 consists of a cylinder slightly conical or spherical rotating at one-quarter the speed of the crankshaft. It is hollowed out in two cells K and K', the chords of which are equal to the bore of the cylinder. As the distributor rotates it covers and uncovers the ports A and E for the intake and exhaust respectively. The cylinder head is a communication with the base chamber of the motor which is hermetically sealed by the pipe T and by the exterior air by the port B<sup>a</sup>.

Referring to Fig. 2, the left-hand illustration (A) shows the valve at the end of the suction stroke, the intake port A and the exhaust port E are covered and the piston P on its upward stroke will compress the gas in the concave cell K, but at the same time as the base chamber H in Fig. 1 is hermetically sealed a depression is produced. Pure air sucked in from the exterior enters by the port B<sup>a</sup>, filling the cavity K' and will enter by the pipe T into the base chamber.

Again referring to Fig. 2, (B) shows the piston at the top of the compression stroke and the cavity K is placed symmetrically over the piston thereby forming a hemispherical compression space.

The suction of air in the base chamber will have finished by this time and the expansion will commence. (C) shows the piston at the lower dead center, and the expansion is terminated. As the exhaust is about to commence the exhaust port E will be uncovered and the cavity K will be placed in communication with the atmosphere.

Examining the last phase of the cycle at Fig. 2 (D) will show the piston at the top dead center. The burned gases have been completely displaced from the cylinder, due to the position taken by the distributor which exactly fills the cavity formed by the head of the piston. At this moment the piston commences to descend and the cavity K' places the cylinder in communication

with the carbureter and the intake stroke commences. At the same time the piston compresses the fresh air previously taken in to the base chamber by the port B<sup>a</sup> and the cavity K'. The cavity K remains in communication with the atmosphere through the exhaust port E, and the air compressed in the base chamber finding an exit by the pipe T, and the port B<sup>a</sup> placed about 45 degrees from E ejects through the orifice E the burned gases that remain in the cavity K after being expelled from the cylinder. This expulsion takes place after the time when the piston will have descended to the lower dead center. By that time one of the sides of the cavity K will obstruct the exhaust port E and the other side will open B<sup>a</sup> as was shown in the first position of the piston when this latter rises, sucking pure air, but this time by the cavity K.

It should be noticed that when the distributor takes the position as shown at (B) and (C) in Fig. 2 the piston has compressed and allowed the gas in the crankcase to expand, the orifice B<sup>r</sup> being covered. One could profit by this to place in the pipe T a valve or distributor and compress the air in a reservoir which could be used for automatically starting the motor, pumping the tires, working sound signals or brake application, thereby saving the installation of a pump specially designed for these purposes.

This description of the workings of a motor scavenging the burnt gases only takes into consideration the base chamber of the motor itself as an air compressor, but it is clear that it is

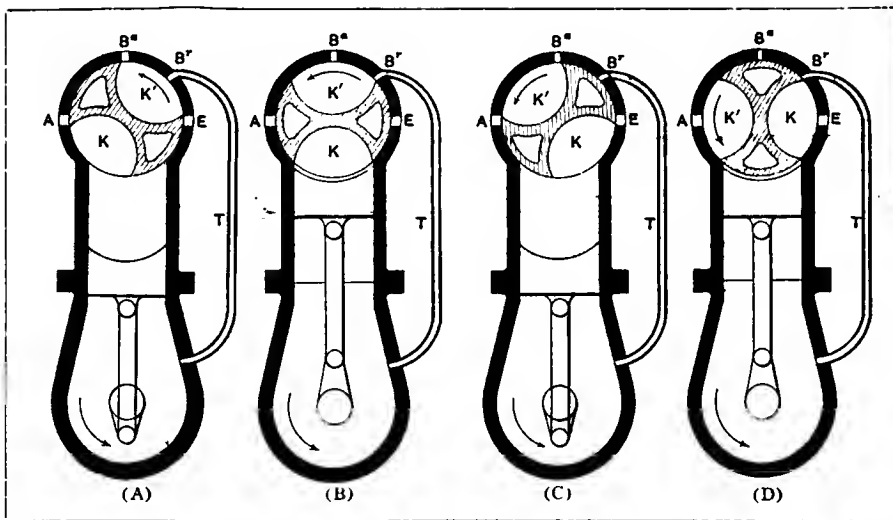

Fig. 2—A, the position of the valve at the end of the induction stroke; B, position of the valve at the end of the compression stroke; C, position of the valve at the end of the expansion stroke with the port E about to be uncovered; D, exhaust stroke having been completed the valve is about to open the port A

possible to have a separate compressor outside the motor. In that case there would only be a simple explosion from B<sup>r</sup> to E and the port B<sup>a</sup> could be suppressed if it were found desirable. In order to obtain a self-starter it would be sufficient in several multi-cylinder motors to open a cock to allow the compressed air to enter in one or several of the cylinders through the cavities of the distributor. It could also be obtained by the movement of the distributor to a certain angle. It would be necessary to give some advance to the valve in practice to take care of the lag in opening.

# Calendar of Coming Events

## Handy List of Future Competitive and Show Fixtures

### Shows

- Jan. 1-5.....New York City, Grand Central Palace, Annual Show, Automobile Manufacturers' Association of America.
- Jan. 6-13.....New York City, Madison Square Garden, Twelfth Annual Show, Pleasure C. Division, Automobile Board of Trade.
- Jan. 10-17.....New York City, Madison Square Garden, Annual Show, Motor and Accessories Manufacturers.
- Jan. 10-17.....New York City, Grand Central Palace, Twelfth Annual Show, National Association of Automobile Manufacturers.
- Jan. 15-20.....New York City, Madison Square Garden, Twelfth Annual Show, Commercial Division, Automobile Board of Trade.
- Jan. 27-Feb. 10....Chicago Coliseum, Eleventh Annual Automobile Show under the auspices of the National Association of Automobile Manufacturers.

### Race Meets, Runs, Hill-Climbs, Etc.

- Aug. 12-18.....New Orleans-to-Memphis Good Roads Tour, New Orleans Picayune.
- Aug. 12.....Baltimore, Md., Track Races.
- Aug. 12.....Philadelphia, Reliability Run, Quaker City Motor Club.
- Aug. 12.....Worcester, Mass., Hill Climb, Worcester Automobile Club.
- Aug. 17.....St. Louis, Mo., Reliability Run, Missouri Automobile Assn.
- Aug. 25-26.....Elgin, Ill., Stock Chassis Road Race, Chicago Motor Club.
- Sept. 1.....Oklahoma, Reliability Run, *Daily Oklahoman*.
- Sept. 2-4.....Brighton Beach, N. Y., Track Races.
- Sept. 4.....Denver, Col., Track Races, Denver Motor Club.
- Sept. 7-8.....Philadelphia, Track Races, Philadelphia Auto Trade Association.
- Sept. 7-9.....Hamline, Minn., Track Races, Minnesota State Automobile Association.
- Sept. 7-10.....Buffalo, N. Y., Reliability Run, Automobile Club of Buffalo.
- Sept. 9.....Augusta, Me., Hill Climb.
- Sept. 13.....Grand Rapids, Mich., Track Races, Michigan State Auto Association.
- Sept. 15.....Knoxville, Tenn., Track Races, Appalachian Exposition.
- Sept. 16.....Syracuse, N. Y., Track Races, Automobile Club and Dealers.
- Sept. 18-20.....Chicago, Ill., Commercial Reliability Run, Chicago Motor Club.

- Sept. 23.....Detroit, Mich., Track Races, Michigan State Agricultural Society.
- Sept. ....Brighton Beach, N. Y., Twenty-four-Hour Race.
- Sept. ....Denver, Col., Track Races, Denver Motor Club.
- Sept. ....Detroit, Mich., Reliability Run, Wolverine Automobile Club.
- Sept. ....Steubenville, O., Hill Climb, Automobile Club of Jefferson County.
- Oct. 3-7.....Danbury, Conn., Track Races, Danbury Agricultural Society.
- Oct. 7.....Philadelphia, Fairmount Park Road Races, Quaker City Motor Club.
- Oct. 9-13.....Chicago, Ill., Thousand-Mile Reliability Run, Chicago Motor Club.
- Oct. 13-14.....Atlanta, Ga., Track Races.
- Oct. 14.....Santa Monica, Cal., Road Races.
- Oct. 16-18.....Harrisburg, Pa., Reliability Run, Motor Club of Harrisburg.
- Nov. 1.....Waco, Tex., Track Races, Waco Auto Club.
- Nov. 2-4.....Philadelphia, Reliability Run, Quaker City Motor Club.
- Nov. 4-6.....Los Angeles, Phoenix Road Race, Maricopa Auto Club.
- Nov. 9.....Phoenix, Ariz., Track Races, Maricopa Automobile Club.
- Nov. 9, 11, 12.....San Antonio, Tex., Track Races, San Antonio Auto Club.
- Nov. 27.....Savannah, Ga., Vanderbilt Cup Race, Savannah Automobile Club.
- Nov. 30.....Los Angeles, Cal., Track Races, Motordrome.
- Nov. 30.....Savannah, Ga., Grand Prize Race, Savannah Automobile Club.
- Nov. ....Columbia, S. C., Track Races, Automobile Club of Columbia.
- Dec. 25-26.....Los Angeles, Cal., Track Races, Motordrome.
- Date in def.....Port Jefferson, L. I., Hill Climb, Port Jefferson Automobile Club.
- Date in def.....Riverhead, L. I., Road Race, Port Jefferson Automobile Club.

### Foreign Fixtures

- Sept. 2-11.....Roubaix, France, Agricultural Motor Vehicle Show.
- Sept. 9.....Bologna, Italy, Grand Prix of Italy.
- Sept. 10-20.....Hungarian Small-Car Trials.
- Sept. 16.....Russian Touring Car Competition, St. Petersburg to Sebastopol.
- Sept. 17.....Semmering, Austria, Hill Climb.
- Sept. 17.....Start of the Annual Trials Under Auspices of *l'Auto*, France.

# THE AUTOMOBILE

Vol. XXV Thursday, August 10, 1911 No. 6

## THE CLASS JOURNAL COMPANY

H. M. SWETLAND, President  
A. B. SWETLAND, General Manager  
231-241 West 39th Street, New York City

### EDITORIAL DEPARTMENT

THOS. J. FAY, Managing Editor  
GEORGE M. SCHELL, Associate Editor  
JAMES R. DOOLITTLE HUGH P. MacCONNELL  
HANS WEYSZ

### ADVERTISING DEPARTMENT

W. I. RALPH, 1035 Old South Bldg., Boston  
C. H. GURNETT, 910 South Michigan Avenue, Chicago  
L. G. VOGEL, Avenue, Chicago  
T. B. VAN ALSTYNE, New York and Phila.  
H. L. SPOHN, New York  
LOUIS R. SMITH, New York  
FRANK B. BARNETT, 309 Park Building, Cleveland  
H. H. GILL, 627 Ford Building, Detroit

Cable Address - - - - - Autoland, New York  
Long Distance Telephone - - - - - 2046 Bryant, New York

### SUBSCRIPTION RATES

United States and Mexico - - - - - One Year, \$3.00  
Other Countries in Postal Union, including Canada - - - - - One Year, 5.00  
To Subscribers—Do not send money by ordinary mail. Remit by Draft, Post-Office or Express Money Order, or Register your letter.

### FOREIGN SUBSCRIPTION AGENTS

ENGLAND—W. H. Smith & Sons, Ltd., 186 Strand, London, W. C., and all book-stalls and agencies in Great Britain; also in Paris at 248 Rue de Rivoli.  
FRANCE—L. Baudry de Saunier, offices of "Omnia," 20 Rue Duret, Avenue de la Grande Armee, Paris.  
GERMANY—A. Seydel, Mohrenstrasse 9, Berlin.

Entered at New York, N. Y., as second-class matter.  
The Automobile is a consolidation of The Automobile (monthly) and the Motor Review (weekly), May, 1902, Dealer and Repairman (monthly), October, 1903, and the Automobile Magazine (monthly), July, 1907.

WHEN the makers of automobiles promise to deliver a certain number of cars at a given time and the agencies of the companies are induced to rely upon any such promise, it requires no very great amount of discrimination in reaching the conclusion that the agents will suffer great pecuniary loss unless all such promises are scrupulously kept. How to keep a promise of delivery is a simple matter if the system in vogue in the plant where the cars are made is up to the level of the task. But how many heads of companies fully realize the importance of having a well-worked-out system for routing the work and keeping the parts that compose the cars so completely on the go that they will come out finished on time?

\* \* \*

LOOKING at this matter from another and even more important angle, how about the makers of automobiles who idle away a large part of the construction year in a futile effort, finding when it is too late that the work, at least a large part of it, will have to be done on overtime? Who will say that the work as done at night will be as good as the work that is done in a well-kept shop in the daytime? The sap of profit of the industry is most likely to be wasted at night when the work is done in this way, and too often the character of the work sinks to a low ebb. This would all be avoided were it possible to bring the manufacturing process of adopting a shop system.

THERE is still another reason why a good shop system is needed. No company can afford to disappoint its customers. It will be fatal to the reputation of a maker to accept the deposit of a purchaser, promising delivery at a certain date, and fail to keep faith. Not a few users of automobiles have been disappointed in this way. Not one of these disappointed purchasers will have a good word for the maker who is at the bottom of the trouble. It is far from good practice to pay large amounts of money for advertising and other sales work of a missionary character, getting "prospectives" into a receptive state of mind, if it is for no better purpose than to arouse their spleen.

\* \* \*

STRANGE as it may seem, there are many difficulties in the path of the engineer who essays to build a good automobile by way of the parts maker. It is not that the parts, when properly made, are not all that they should be; the real difficulty is that the engineer who relies upon the maker of the parts for his source of supply is prone to allow the work to go on to the end without checking up the activities of the maker of the parts. The engineer, if he finds that the parts are not up to his standard, makes the discovery when it is too late to be of any service to him. It is just as necessary to inspect parts that are being made by a maker of parts as it is to keep an eye on the parts that are being made in the home plant. It would be too much to expect that the parts maker could build so much better than the home work that it would be unnecessary to inspect the work. Instantly it is deemed necessary to make inspections, it only remains to say that the best man to do the inspecting is he who guarantees the product to the purchaser, since the risk must fall upon him.

\* \* \*

WHILE it is scarcely to be expected that the world's supply of stupidity will give out this side of the millennium, the fact remains that there is no good reason why railroad companies should hold a monopoly of this atmosphere of the obtusely inclined. Take, for illustration, grade crossings; the idea that it costs too much to eliminate them is a threatening situation to contemplate. If a railroad company cannot see its way clear to eliminate these terrible instruments of destruction, then, the question is, Can the traveling public afford to risk life and limb in its cars; on its roadbed, or in its care? The leading story in THE AUTOMOBILE this week will suffice to show that grade crossings are a menace to the public, nor can it be claimed that it is the automobiling public alone that is doing all of the suffering. But even were it possible to say that only automobilists suffer from this class of neglect, who will care to go on record as advocating that this type of grave danger be continued? That the railroad company is not to be relied upon to cure the disorder is a matter that can be easily proven; for several years the head of one of the railroads in the vicinity of New York has been claiming in public print that it is the automobilist who is at fault! It is admittedly against public policy to electrocute a railroad president every time a citizen is killed by a railroad train, but this is no good ground for claiming that a man should be crushed under a railroad train just because he is the owner of an automobile!

# M. C. A.'s Most Important Meeting

## Essential Elements of Racing on Trial

*First in size and importance among all the meetings that have ever been held by the Manufacturers' Contest Association as far as racing and contests are concerned is the one scheduled to commence to-day at Detroit, which will remain in session over to-morrow. The fate of stock cars as such in competition, of reliability tours, of truck trials and circular-track competition are all to be discussed.*

**D**ETROIT, Aug. 9.—Preparations have been made to accommodate fully two-thirds of the representatives of members of the M. C. A. and a list of twenty or more invited guests at the meeting of the General Rules Committee of that organization which will take place to-morrow and Friday in this city. The guests referred to include the members of the Board of Review—the Supreme Court of motordom—and heads and members of the Technical Committee and Contest Board as well as others.

The program of the meeting is the most important ever taken up by the M. C. A. and includes consideration of and action upon the essentials of automobile sport. Among the subjects to be considered are the questions as to the advisability of insisting on strict stock classifications in contests of that variety; as to the advisability of holding reliability tours, and, if so, what kind and how many; whether the rules governing truck contests and trials are adequate and equitable and whether such trials are of service, and as to the holding of sanctioned meetings on ordinary one-mile dirt tracks.

Under each of these four heads there will be a wide discussion and it is quite likely that some radical action may develop as a result of the meeting. Among the general topics that will have attention will be the following: Shall the Contest Board promote any contest? Shall special rules be made or special dispensations granted for any event within thirty days of the start of such contest? What shall be the definition of a "contest"?

If the committee decides to abolish stock car contests, or bars racing on mile tracks, or frowns on truck trials, or decides not to countenance national reliability runs and tours the result will be a radical change in the sporting situation. Such rulings are not looked for by the trade generally, but the mere fact that the M. C. A. is considering them at all is taken as an evidence that the contests in 1911 so far have not proven broadly satisfactory as to volume or results.

### Nobody Knows the New York Speed Law

New York courts and police are somewhat mixed as to the proper construction of the speed law as it applies to New York City, if it does at all. In a recent issue of THE AUTOMOBILE the present situation was clearly outlined and forecasted and automobilists were cautioned that the law is uncertain and that the only safe way to proceed is to obey the orders of the traffic squad no matter what they may be.

One magistrate has held that a speed of thirty-miles-an-hour is not illegal if traffic conditions do not make such speed perilous to life and property. Another judge has decided that the old ordinance framed in the days of horse-drawn traffic limiting the speed to 8 miles an hour is still legal and binding. The Police Commissioner has placed the responsibility for construing the law upon his officers individually without defining the law, and

all told the situation is exactly as THE AUTOMOBILE described it. Obey the traffic squad and keep out of court.

### Chicago Run to Be Eight-Day Affair

**CHICAGO, Aug. 7**—The Chicago Motor Club to-day decided to make its annual reliability run, set for October, an eight-day tour instead of the usual four days and a route running through five States was adopted. The night stops will be: Indianapolis, 213 miles; French Lick, 190; Louisville, 58; Cincinnati, 170; Columbus, 200; Detroit, 190; Grand Rapids, 190; Chicago, 215, a total of 1,426 miles. The tour is to start October 6 instead of 9 and will extend to Oct. 13 inclusive. The pathfinder will be a Halladay, which will start out immediately after the Elgin road races.

### Show Committee to Hold Meeting

Tentative arrangements for holding the next automobile show in Madison Square Garden will be discussed at the meeting of the show committee of the A. B. of T. this week. The plans so far as they have developed contemplate a gigantic exhibition. The full membership of the organization, as it concerns participation in the show, will be known after the next regular meeting of the Executive Committee which is scheduled for September 6. The drawing for space will take place shortly after the meeting.

### Sporting Events Are Stirring

Racing and sporting matters are looking up a trifle and the indications now are for a lively season until snow flies. Among the events scheduled for decision in the near future are a hill-climb at Port Jefferson, Sept. 9; a beach meet at Old Orchard; a 200-mile road race at Columbus, O., on Sept. 2 and a tentative road race at Cincinnati on the occasion of the opening of the new Fernbank dam which insures a 9-foot stage of the Ohio river all the year around at Cincinnati. This race is proposed for Sept. 9.

### Remy Brassard Changes Hands Again

**SCRANTON, PA., Aug. 7**—The Remy Grand Prize changed hands again at the race meeting held here to-day on the half-mile track of the Minooka Driving Club. The Blitzen Benz (Burman) defeated the Mercedes (Knipper) in straight heats, both cars and drivers being controlled by the same interests. A program of non-stock events was run off in connection with the big race. The winners turned up in a Buick, Hotchkiss, Ohio, and Buick.

### Premier Caravan at San Francisco

**SAN FRANCISCO, Aug. 7**—The entire Premier caravan consisting of ten touring cars, a pacemaker and a prairie-schooner trundled up the peninsula from San Jose last week and came to anchor beside the Golden Gate. The tourists were met with acclaim and were given a rousing reception. The cars started from Atlantic City and will finish at Los Angeles. Everybody who started is still with the caravan and as enthusiastic as at the time of starting.

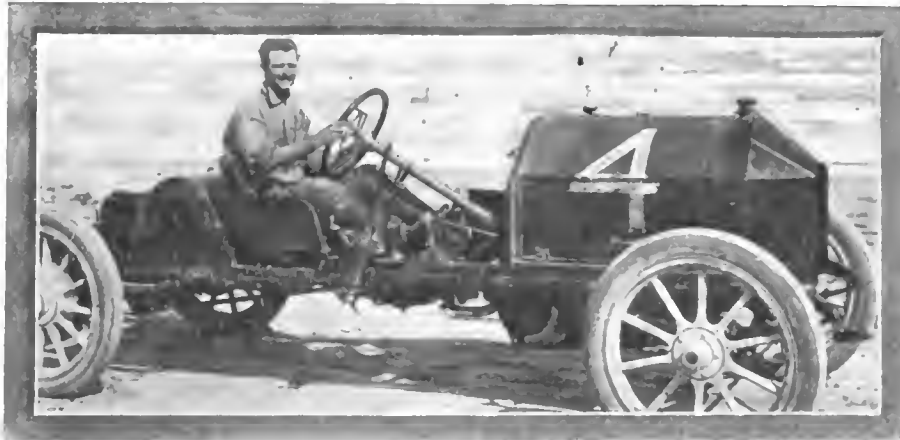

Cadillac, George De Witt, driver, which won two races at the Galveston beach meet

# Fast Racing Nationals Win Stock

Three days of beach racing at Galveston la satisfactory contests. In the ma special racer from the National facto race. The stock car events furnis point of racing. The National stock a Cadillac two, and Columbus one rac small and running close.

**G**ALVESTON, TEXAS, Aug. 3—The first day of the three days' automobile race meet on Galveston beach speedway brought out a crowd of about 20,000 spectators, and the events were carried through with satisfaction and success. The races were held under the auspices of the Galveston Automobile Club and in connection with the annual Cotton Carnival held here. Members of automobile clubs from all over Texas were in attendance.

The beach was in good condition for the races, firm and smooth, with a favorably low tide after 3 o'clock in the afternoon. No accident of any nature occurred to mar the events. The course was laid out in laps of two lengths. For 10-mile races the lap was 5 miles, allowing the drivers to pass in front of the grandstand four times during the race, and for the 20 and 50-mile races the lap was 10 miles.

The fact that an end has been put to automobile racing on circular tracks in Texas gave an added importance and interest to this meet. Automobile men from all over the State came to Galveston in their cars for these races. A party comprising 35 cars, carrying 100 people, came from Dallas, piloted by George W. Baker of that city, president of the Texas State Automobile Association. Two weeks before the meet President Baker made a pathfinding trip over the route, ascertaining the best course and enlisting the interest of automobile owners along the way. From San Antonio about 30 cars came, and from other cities and towns there were enough to bring the total number of visiting cars up to one hundred.

The first day's events consisted of three stock car races and one non-stock, free-for-all race, as shown in the summaries below. In the stock events the first prizes ranged from \$100 to \$150, and the second prizes from \$25 to \$50. In the 50-mile, free-for-all race the prizes were \$250, \$75, and \$25.

The feature race of the day was the 50-mile, non-stock race.

There were eleven starters in this, with cars from some of the best factories in the country. The race was won by a 50-horsepower National (Zengel). His time was 42:9 1-2. This is the record for this distance on this course. Zengel's real competitors in this race were another National car, driven by Neal McHugh, and an Inter-State driven by Harry Endicott. Zengel took the lead from the start and never lost it, finishing 2 minutes and 48 seconds ahead of the other National car, and 3 minutes and 35 seconds ahead of the Interstate. A Pope-Hartford machine maintained a fourth position in the race from the start to the finish, piloted by Harry Baker.

Class B, Stock Chassis, Division 2-B, 10 Miles					
Car	Bore	Stroke	Driver	Time	
Ford	3 3-4	4	Albert Hoffman	11:17	
Abbott-Detroit	4 1-8	4 1-4	M. J. Roberts	11:24 1-5	
Class B, Stock Chassis, Division 4-B, 20 Miles					
National	5	5 11-16	Len Zengel	16:49	
Pope-Hartford	4 3-4	5 1-2	Harry Baker	19:00	
Class B, Stock Chassis, Division 3-B, 10 Miles					
Cadillac	4 1-2	4 1-2	George de Witt	11: 7 1-2	
Marion	4	4 1-2	James Geary	11:19	
Class D, Non-Stock, Free-for-All, 50 Miles					
National	5	7 1-2	Len Zengel	42: 9 1-2	
National	5	5 11-16	Neal McHugh	44:57	
Interstate	5	6	Harry Endicott	45:46	
Pope-Hartford	4 3-4	5 1-2	Harry Baker	47:40	
Cadillac	4 1-2	4 1-2	George De Witt		
Marion	4	4 1-2	James Geary		
Cutting	5	6	Joe Swain		
Jackson	4 7-8	4 3-4	M. A. Holmes		
Abbott-Detroit	4 1-8	4 1-4	M. J. Roberts		
Ford	3 3-4	4	Albert Hoffman		
Marmon	4 1-2	5	Ben Johnson		

## Second Day's Races Saw Course Mile Record Broken

**GALVESTON, Aug. 4**—The principal feature marking the second day of the meet was the fixing of a new record on this course for the mile from a flying start. Len Zengel, driving a high powered, specially built National car No. 12, made a mile in 37 4-5 seconds, or at the rate of 95.23 miles per hour. The previous record, established in 1910, was 40 3-5 seconds. It was made by a Chadwick (Zengel).

The honors of the day went for the most part to National cars. They won both of the non-stock events, as shown in summaries below, and also captured first money in one of the stock races. The stock car which made such a good showing was No. 18 and the non-stock was No. 12.

In event No. 6, a stock race between an Abbott-Detroit and a Ford, the Ford entry was protested on the grounds that the car was too light for the class. No decision was rendered. The summary:



Albert Hoffman in the Ford racer in which he won the 2-B 10-mile race at Galveston Beach



# at Galveston and Special Events

week attracted large attendance and some however, the cards were topped by a big, which won every time it was dropped into a something more spectacular from the view-won three events; while the Ford won two. Except in the free-for-alls the fields were



Inter-State car which took part in the races, with Harry Endicott at the wheel

**Class B, Division 3-B, Stock Chassis, 20 Miles**

Car	Bore	Stroke	Driver	Time
National	5	5 11-16	Len Zengel	18:27 1-2
Pope-Hartford	4 3-4	5 1-2	Harry Baker	23:45

**Class B, Stock Chassis, Division 2-B, 20 Miles**

Ford	3 3-4	4	Albert Hoffman	23:22
Abbott-Detroit	4	4 1-2	M. J. Roberts	26:07

**Class E, Non-Stock, Mile, Flying Start**

National	5	7 1-2	Len Zengel	:37 4-5
National	5	6 11-16	Neal McHugh	:41
Interstate	5	6	Harry Endicott	:42 2-5
Marion	4	4 1-2	James Geary	:57 1-2
Cadillac	4 1-2	4 1-2	George De Witt	:58
Pope-Hartford	4 3-4	5 1-2	Harry Baker	:52 3-5
Cutting	5	6	C. E. Linxwiler	:48 3-5
Abbott-Detroit	4 1-8	4 1-4	M. J. Roberts	:45

**Class G, Electric Pleasure Cars, 5 Miles**

Columbus		James Collins	13:21
Babeck		Cortes Pauls	15:50
Columbus		E. Wallington	

**Special Event for Texas State A A Trophy, 50 Miles, Non-Stock**

National	5	7 1-2	Len Zengel	40:39 4-5
Interstate	5	6	Harry Endicott	
National	5	5 11-16	Neal McHugh	
Cutting	5	6	C. E. Linxwiler	
Marion	4	4 1-2	James Geary	

**150-mile Race Featured Third Day**

GALVESTON, Aug. 5—The big event of the third and last day of the meet was the 150-mile race for non-stock cars. This was won by the special racing National No. 12 (Zengel), making the distance in 2 hours, 6 minutes and 6 seconds. Another National car, stock chassis, driven by W. Rader, came in for second money, finishing the 150 miles in two hours, 10 minutes and 36 seconds. An Interstate special car, driven by Harry Endicott, was third, the time being 2 hours, 44 minutes and 15 seconds. A Ford car finished fourth, time 3 hours and 1 minute, Albert Hoffman driver. The prizes in this race were \$750, \$250 and \$100.

There were 10 starters in this event. A Cadillac car was the only one running when the race was called. It had finished 130 miles. Zengel's National made the first 50 miles in 42 minutes, the 100 miles in 83:04, 120 miles in 100 minutes and the 150 miles in 126:06. The two National cars ran the race without a stop for any purpose.

The Cadillac went the hundred miles, or 10 laps, in 140:46. The Ford went the 100 miles in 122:20. The two were the only cars that ran as much as the 100 miles, except the winners mentioned above. The Jackson and the Abbott-Detroit made 9 laps, or 90 miles. The summary:

**Class B, Division 3-B Stock Chassis, 10 Miles**

Car	Bore	Stroke	Driver	Time
Cadillac	4 1-2	4 1-2	Geo. De Witt	11:09 2-5
Marion	4	4 1-2	Van Curtis	12:10

**Class B, Stock Chassis, Division 4-B, 10 Miles**

National	5	5 11-16	Len Zengel	10:15 4-5
Pope-Hartford	4 3-4	5 1-2	Harry Baker	10:16

**Class D, Non-Stock, Free for All, 150 Miles**

National, 12	5	7 1-2	Len Zengel	126:06
National, 18	5	5 11-16	W. Rader	130:36
Interstate	5	6	H. Endicott	164:15
Ford	3 3-4	4	Albert Hoffman	180:01
Cadillac	4 1-2	4 1-2	Geo. De Witt	
Pope-Hartford	4 3-4	5 1-2	Harry Baker	
Jackson	4 7-8	4 3-4	Melun	
Abbott-Detroit	4 1-8	4 1-4	M. J. Roberts	
Marmon	4 1-2	5	Ben Johnson	
Ranier	5	5 1-4	W. P. Hall	

The racing officials for the three days' events were: Racing Committee—Chairman, M. O. Kopperl; J. W. Munn, J. A. Black. Referee—Judge Lewis Fisher. Technical Committee—Chairman, R. W. Carr, G. A. C. Half, Dr. J. C. Ralston, Captain L. Luth. Starter—S. H. Boren. Assistants—Lee Kempner, G. F. Cotton. Judges—Chairman, G. W. Baker; J. R. Cheek, H. A. Black. Timers—Chief, George Sealy; S. Reinhardt, Dave Burks. Scorers—Chief, Fred Hartel; R. E. McKie, Eli Sanger.



Len Zengel in National leading on the first lap of 50-mile race on first day of Galveston beach meet



Making the new turn from Norwood Avenue into La Roche Avenue.



Gang of convicts working on the Whitfield Avenue cut-off

## Grand Prix Course Under Harrow

### Turns Being Cut and Curves Banked

*Sixteen weeks before the first of Savannah's quartette of great road races, the course over which they will be run is in process of radical improvement. In two places short cuts will take a few hundred feet from the circuit and the four chief turns, all of which are rectangular, will be high-banked. New road is being built to eliminate the detour at Wylly Island and Whitfield avenue will be practically cut out of the course by the stretch under construction through the forest.*

SAVANNAH, GA., Aug. 7—Although the first of the great road races that will be run off at Savannah this fall is still sixteen weeks away, work is being pushed on the course upon which it will be held. The Vanderbilt Cup, scheduled to be run with the Tiedeman Trophy and Savannah Challenge Cup races on November 27, will be followed on Thanksgiving Day by the Grand Prize of the Automobile Club of America. The course which is approximately 17 miles long is being shortened a trifle and vastly improved on the turns.

Big gangs of involuntary servitors are laboring with road-making machinery to shape the course accomplish some important improvements. Starting from the grandstands just after the turn has been made into Waters Road from Dale avenue, the 1911 course will follow Waters Road just as it did last year to its junction with the Montgomery Cross Road. Here there is a 90 degree turn which was not banked high last year. This Fall the turn will be banked so that contestants will not have to shut down to take it. From there is a 1,500-foot stretch of roadway on Montgomery Cross Road to the junction with Whitfield avenue. The right turn will be banked and instead of following Whitfield avenue to the crossing of the Montgomery Road, a new course is being cut through the woods several hundred feet inside of Whitfield avenue and the bad turn that formerly marked the point of emergence into Montgomery Road has been modified by eliminating the curve. From there to the extreme end of the hairpin turn into Ferguson avenue the course is the same as last year, but at the turn a heavy em-

bankment is being raised just beyond the bridge which affords passageway into the infield.

No changes will be made in the long fine stretch of roadway afforded by Ferguson avenue until the course reaches the Norwood line, where instead of following down to the edge of Wylly Island and winding through to Laroche avenue, a short cut through the timber is being built which will cut off several hundred feet and eliminate two dangerous turns.

Along Laroche avenue the way will be identical with that followed in 1910 to the turn into Dale avenue. This will be banked and made easier and the run to the last turn will be the same. At the turn there will be another stiff embankment to remove a portion of the factor of danger that was so apparent in the final spurt to the wire.

There is an immense amount of enthusiasm for the quartette of races and those in charge of the event make no secret of their confidence of assembling a magnificent field for each event.

The changes and improvements in the course will probably render it about 350 feet shorter than it was in 1910, while the elimination of the curves due to these improvements and the banking of those that remain will probably make the course considerably faster. It is estimated that the average time for the rounds will be in the neighborhood of eleven or twelve seconds faster than before and if the road surfaces are also conscientiously bettered, this time may be improved as much as fifteen seconds. It is predicted that the car that makes the fastest round will lower the time mark of 1910 by possibly twenty seconds, despite the fact that certain miles were turned last year well over the 100-mile-an-hour notch.

The terrific turns which were practically unbanked last year caused most of the tire trouble that was suffered by certain contestants. This was particularly true of the turn from Montgomery Road into Ferguson avenue which was two right angles. The heavy banking on the Ferguson avenue side will probably give many of the cars an opportunity to avoid the terrific strains and wear on their right rear wheels and tires.

There is considerable disappointment expressed locally that the proposed Glidden Tour which is now scheduled to finish at



Before oiling the course it is thoroughly gone over with sweepers



The oiling of the course is being carefully and evenly done

Jacksonville, Fla., was not routed nearer to Savannah or at least delayed to finish toward the middle of November instead of October 25 as announced. By making these changes in route or time or both, the people here believe that the attendance of a large number of Northern automobilists taking part in the tour could have been insured for the big races.

As it is, a determined effort will be made before the start to interest the tourists in the idea of staying in the South until the road races and attending as individuals. There will also be a party of missionaries to greet the tour at Jacksonville and attempt to persuade the contestants to run over to Savannah.

It is reported here that the real reason why the Glidden was not routed through Savannah was that the roads south to Jacksonville have numerous bad spots and that frequent ferriage is required across the streams and bayous that lie between and the obstacle that stands in the way of a later start than the one scheduled is that if the tour starts from New York later than the date agreed upon in October there is a strong likelihood of meeting bad weather in New Jersey and the certainty of encountering disagreeable conditions in the Virginia hills. Work is progressing on the big new hotel and everything is lovely regarding the preliminaries with the exception of the disappointment that is apparent about the Glidden.

## Dead Horse Climb Next

*Most important of its kind in the East this season, the coming meeting on Dead Horse Hill under the auspices of the Worcester Automobile Club promises to outshine anything of the kind ever held on the course. A series of stock car events will be a feature of the occasion. The climb will take place Saturday, August 12. Something over sixty entries have been offered by factories, dealers and individuals although several have not been accepted.*

WORCESTER, MASS., Aug. 7—Easily the leading event of its kind this season in the East will be the annual climb of Dead Horse Hill near this city which will be staged by the Worcester Automobile Club, Saturday, Aug. 12. The management promises with good weather to have a record-breaking crowd in attendance and the field of entries is by far the largest and most representative that has ever been gathered together for a hill climb over this course.

It is predicted that the record of the hill will be lowered in competition and that new marks in the various stock classes will be made. For the first time this year in the East there will be a series of stock car events under formal supervision. Such events if carefully conducted as to preliminary examinations are intended as ocular proof of the hill-climbing ability of actual

stock models and as such are of considerable importance to the public.

Besides the stock car races there will be a spectacular program of free-for-all events for the special speed creations and, as these usually develop some thrilling situations, the prospects for a meeting of sustained interest are excellent.

In the past a special point has always been made of keeping the public informed of the progress of each race and this year the preparations along that line are even more comprehensive than heretofore. The timing will be done by an electrical machine which belongs to the Worcester Polytechnic Institute and will be handled by Professor David L. Gallup, head of the department of Gas Engineering of the institution.

It is a device with a drum upon which paper is rolled and is driven at constant speed by a motor. The tripping of a wire at the start causes a dot to be made on the roll and when the car passes over the wire at the finish another dot is made. The paper tape will be marked with the event number and car number before the start and will be filed as the official record. Along the course a series of electric gongs have been established which will sound from the instant the starting wire is crossed until the car opens the circuit at the finish by tripping the snap switch. The usual telephone system connecting start with finish and various parts of the hill will be used.

Dead Horse Hill is exactly one mile long and the grade rises 325 feet between the starting and finishing points. Crossing the line there is a dip, followed by a level stretch for about 300 feet, passing over a small bridge. From there a sharp rise averaging 10.3 per cent. begins. This grades off into a gentler slope of 8.3 per cent. to the end of the first quarter. From the quarter pole to the halfway distance the grade is considerably sharper, reaching 12.2 per cent. on an average for over one furlong. The third quarter is a series of jumps with one level shelf 150 feet long. The last quarter is very stiff, in one spot being over 20 per cent. The finishing line is just over the top of the hill.

A. D. Converse will act as referee; H. W. Knights, starter; Prof. David L. Gallup, timer; Frank L. Coes, scorer, and Charles F. Webb, clerk of course. Daniel F. Gay is the moving spirit of the contest committee and is associated with Daniel P. Coughlin and others in arranging the preliminaries.

## Hughes Makes Explanation

According to Hughie Hughes, who drives a Mercer racing automobile, the only trouble that he experienced at the recent race meeting at Point Breeze was but sufficient to render a stop necessary after two tires had blown. in order to prevent running on the rims.

## Detroit Plants to Increase Yield

**D**ETROIT, Aug. 7—Immensely increased 1912 production by the Studebaker Corporation and the United Motors Co., two of the most powerful manufacturing combinations of the industry, were announced here during the past few days.

The Studebaker Co., in its 1912 announcement, states that it plans to build at the E-M-F factories in Detroit a total of 50,000 cars—20,000 of the E-M-F "30" type, and 30,000 of the Flanders "20." This is, of course, in addition to the Flanders Electrics which are being put out at the Pontiac plant of the Flanders Manufacturing Co., but which will, it is believed, be marketed to a great extent through the same dealers.

The 1912 E-M-F "30" will have a lengthened wheelbase—112 inches—and will be put out only in fore-door style, aside from the coupé. Further improvement in finish and the addition of minor details constitute the only other innovations. The three-speed Flanders "20" is now coming through the factory at a rate of 100 a day and the concern hopes to double this speed with the completion of additional factory space, now under construction. The company's announcement states that its advertising campaign has been purposely held back for a month, on account of the complaint of its dealers whom the factory has been unable to supply with enough cars to fill the demand.

The United States Motors announcement was of an informal character and came to light as part of the proceedings at the annual meeting of the central district branch managers of the company, who gathered in Detroit at the call of District Manager Alex. I. McLeod.

Addresses were delivered at various times by Benjamin Briscoe, president of the company, and Horace De Lisser, vice-president, as well as by Alfred Reeves, Fred Dayton, D. C. Fenner, J. J. Aldrich, C. M. Rodgers and T. L. Marshall, all officers of the various divisions of the company.

The production announcement was made by President Briscoe himself. He promised the branch managers an output of 30,000 motor cars and trucks for the coming season, adding that this figure for the Maxwell, Brush, Columbia, Stoddard-Dayton and Alden Sampson plants had been determined on, as the result of long and systematic correspondence with the company's dealers, who, by estimating the sales for their respective territory, indicated their belief that 30,000 cars would be required to supply the demand.

"Our engineers and designers," said Mr. Briscoe, "have been

wise enough to build all kinds of automobiles that our dealers ask for. The men who sell are the ones who know what the public wants and it is our desire to be guided by their ideas on types as well as their ideas of demand."

In attendance at the convention were the following managers of the respective branches: R. K. Davis, Detroit; M. D. McNab, Chicago; E. E. McClure and C. F. Tyler, Cleveland; F. P. Corbett, Columbus; J. W. Hayden, Indianapolis; W. H. McIntyre, Toledo; J. A. Newby, Newcastle; L. G. Murray, South Bend.

A rumor which has gained some credence in Detroit has caused much annoyance at the offices of the Hupp Motor Car Co. This was to the effect that President R. C. Hupp was soon to sever his relations with the company, his intention being to organize a new firm which would manufacture a competing automobile.



Front of the building of the Freehold Motor Company, showing entrance to store and garage

This rumor was flatly denied both at the Hupp Motor Car Co. and later by Mr. Hupp himself. Mr. Hupp believes that the report is probably due to the fact that for some time he has been devoting a large share of his energies to the Hupp Corporation—an entirely separate organization from that of the Hupp Motor Car Co., though including a large number of its directors.

"I am interested as much as ever, both financially and in spirit, with the success of the Hupp Motor Car Co.," said Mr. Hupp. "But I regard its affairs as now on a basis which requires very little attention from me. It is an assured success.

So is the Hupp Corporation, but it is as yet in a formative stage and I can do more good there, I believe. Please deny for me that I am considering any withdrawal from the automobile company, much less the organization of a competing concern."

Quite a number of Detroit-built motor trucks and wagons have been shipped to Chicago to enter the endurance run of the American, the Chicago Automobile Club and the Wolverine Automobile Club. Several of the trucks have been sent overland. The latest comer went that way. It is the Poss, a four-cylinder, 25-horsepower machine of 1,200 pounds capacity. The company was but recently formed and is backed by Frank R. Poss, vice-president of the Detroit Baseball Club. The start of the car for Chicago was made the occasion of a formal farewell, a champagne bottle being broken over the radiator by Sales Manager Joseph M. Ness.

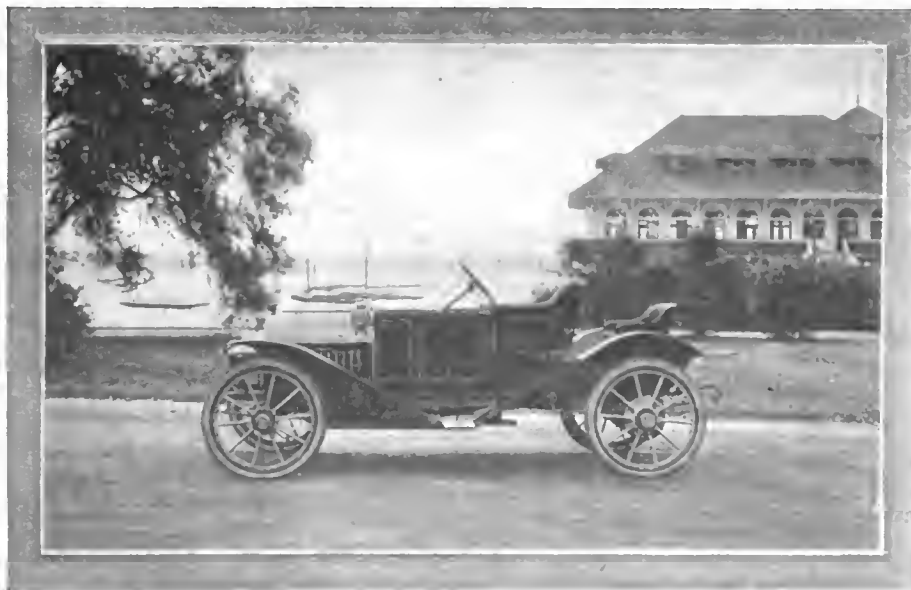

Model 25 1912 Herreshoff fore-door runabout with rumble seat

The Wolverine Automobile Club celebrated "Orphans Day" here Friday and nearly 100 cars were placed at the disposal of the committee. The asylums were all visited and full loads of children were taken on a trip, the itinerary of which included the beautiful residences of the summer colony at Grosse Pointe, and the circuit of Belle Isle.

### Carbureter Makers Offer Prizes.

CHICAGO, Aug. 7—Manufacturers of accessories are chipping in liberally to the prize fund of the national stock chassis road races, booked for Elgin August 25-26, a total of \$3,350 being announced to-day by three concerns which believe the road championships are going to be the greatest motoring events of the year. The Findeisen & Kropf Mfg. Co., of Chicago, maker



Inside the Freehold garage, having an area of almost 7500 square feet; big enough for 80 cars

of Rayfield carbureters, was the first to be heard from with a contribution of \$800; then the Bosch Magneto Co. came forward with an offer of \$950 and to-day the Stromberg Motor Devices Co., of Chicago, offers \$1,600 in cash for the winner.

The Rayfield purse is to go to those winning races in cars equipped with Rayfield carbureters. The winner of the Elgin National is to receive \$500 under these conditions and the winners of each of the other three races is to get \$100.

The Bosch Magneto Co. gives its \$950 provided the Bosch magneto is used. In the Elgin National \$200 is offered for a first, \$100 for second and \$50 for third. In each of the others it is to be \$100 for first, \$50 for second and \$50 for third.

The Stromberg offer is unique in that the carbureter concern offers \$200 to the driver in the Elgin National who makes the fastest lap, regardless of whether he uses a Stromberg. In each of the other races \$100 is offered for the fastest laps and under the same conditions. In addition the Stromberg will give \$500 to the Elgin National winner provided he uses a Stromberg carbureter. In each of the three races the first day \$200 is offered for a Stromberg victory.

Military protection was assured to-day when the Elgin Automobile Road Race Association closed with Colonel Milton J. Foreman for the First Illinois Cavalry for Saturday's races, while on the first day the course will be guarded by militia from Aurora, Rockford and Elgin, 250 soldiers having been secured.

## Splendid Garage in Freehold

JERSEY, the State of fine roads, is not quite as rich in modern, well-equipped garages, but if the new building used by the Freehold Motor Company, of Freehold, N. J., is indicative of the trend in the automobile business of the State, she will soon be able to boast of a number of fine up-to-date establishments. The building here shown contains the storeroom of the agent for Maxwell and Columbia cars in the Freehold territory, the salesroom being 48 feet wide and 40 feet deep, and containing a nice line of most of the prominent automobile accessories.

The garage proper is 60 feet wide and 124 feet deep and has separate entrance and exit for automobiles. Forty cars may be lined up along the walls in a single row, giving a maximum capacity of eighty automobiles. Gasoline pump and compressed air connections are installed in the storeroom, the gasoline storage tank being located outside the building and the air compressor in the machine room. The latter is equipped with a drill press, lathe, shaper and the other repair tools, in addition to the power plant for illuminating the building.

In the garage are a turntable and a traveling hoist, also chemical extinguishers for the case of a fire emergency. The construction of the building is on a fireproof basis throughout. The garage is covered with an extensive skylight, while the front part of the building carries another story, containing a smoking room and parlor.

Frederick D. Bennett is president of the Freehold Motor Company, and William T. Buck holds the position of secretary and treasurer.

### Glidden to Be Won by Team Work

Winning the Glidden Trophy this year will be a matter of team work, according to the official announcement of Chairman Butler of the Contest Board. While cash prizes will be given for winners in the various classes, the main prize will go to the team of three cars, touring cars or runabouts or a combination of both, which shall be designated by the name of the town from which the entries come. The smallest total of demerits will win for the team.

The only chance for a technical examination will occur in case of two or more of the teams being tied for the honors. The tour is scheduled to start October 15 and finish at Jacksonville, Fla., October 25.

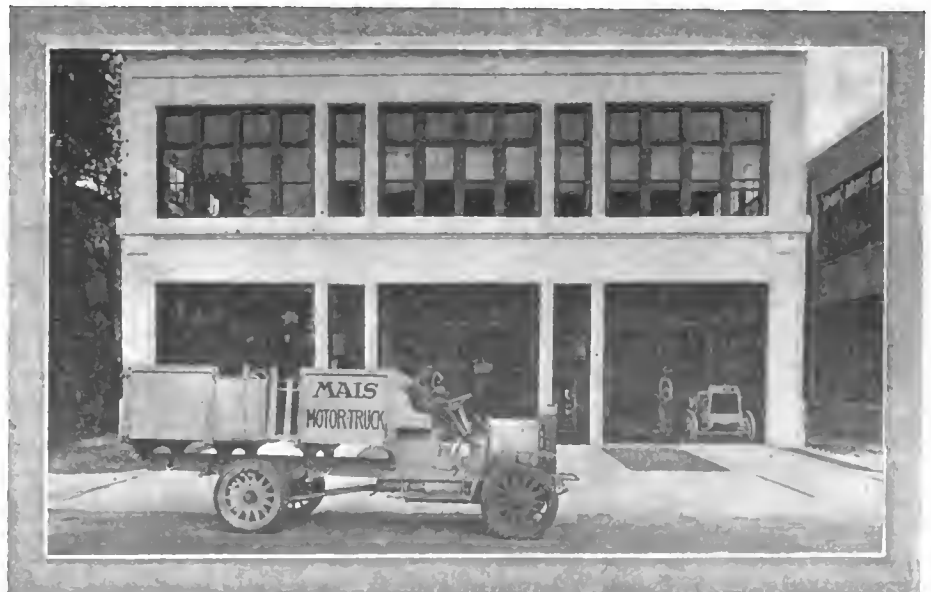

New 2 1/2-ton Mais truck in front of the fire-proof offices of the company at Indianapolis



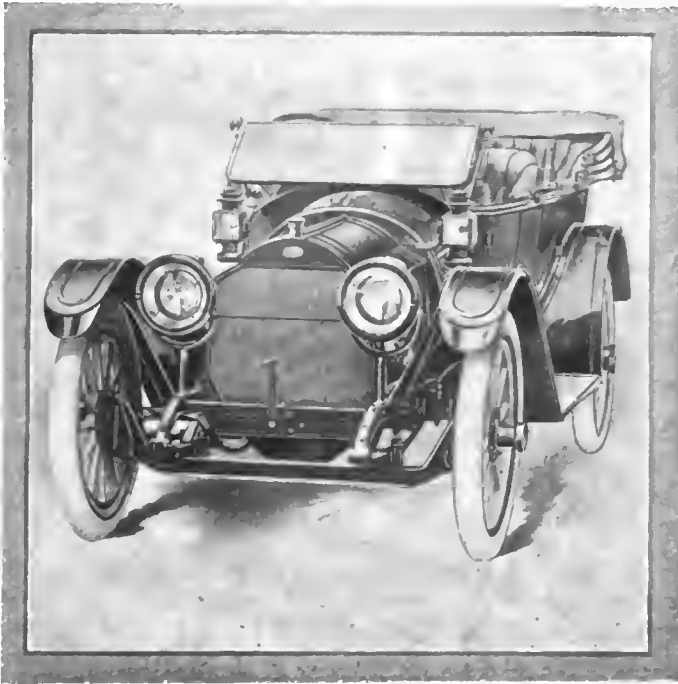

Fig. 1—Front view of the Republic car, showing the general appearance and substantially built front axle.

## The New Republic Car--an Ohio Product

*Built along up-to-date lines, the Republic car, manufactured by the Republic Motor Car Company, of Hamilton, Ohio, is here presented in its current form.*

THE motor fitted to the Republic chassis has four vertical cylinders, water-cooled and cast in pairs. The bore is 4 1-2 inches and the stroke 5 inches. The crankshaft is machined from an alloy steel forging and afterward ground and runs on three bearings of large diameter, being offset 3-4 of an inch from the center of the cylinders. The cylinders having T-heads, the valves are consequently situated on either side, and are 2 1-4 inches across the mushroom. The crankcase is made in two halves, the cylinders being bolted to the upper half, while the lower half serves as an oil well.

A Stromberg carbureter is located on the right side of the motor, the lower half being water-jacketed. As may be seen from the plan view illustration of the chassis (Fig. 3), a flexible metal tube carries hot air to the main air intake to assist carburetion. The gasoline tank is located under the driver's seat on the touring car and under the rear seat on the roadster, having a capacity of 18 gallons. A reserve supply of 3 gallons can be turned on from the driver's seat. Two independent ignitions are provided with two sets of spark plugs. A Bosch magneto is fitted on the same side of the motor as the carbureter and driven off the half-time shaft by a supplementary gear enclosed in the front timing gear case of the motor. A Delco high-tension battery system is used, the distributor being located between the cylinders on the same side as the magneto and driven off the intake camshaft by suitable gearing.

Referring to the lubricating system, the oil drains into an oil reservoir, passing through a fine filter, and is then forced to every

bearing by means of a gear pump through a sight feed oiler situated on the dash. The crankshaft is bored out to allow the oil to flow to the connecting rod bearings, thereby insuring a constant stream at these points. The cooling is effected by means of a honeycomb radiator placed in front of the motor, the water being caused to circulate around the waterjackets by means of a centrifugal pump driven by gearing off the half-time gears. The clutch is housed in the flywheel, the male member being covered with a leather facing with cork inserts to increase the coefficient of friction. The motor is suspended at four points, the arms resting upon supports that are riveted to the side members of the frame.

Fig. 3 shows the assembly of the propeller shaft and the position of the transmission on the rear axle casing. The control levers are placed in the center of the chassis attached to a cross member of the chassis. The propeller shaft is enclosed in a tube that extends from the forward end of the transmission housing to the cross member of the chassis immediately behind the clutch and is attached thereto by means of a forked joint acting in the capacity of a torque member. In addition two radii rods are fitted, the front ends of which abut on brackets attached to the side members. In this construction only one universal joint is employed.

The transmission is of the selective type giving three forward speeds and one reverse, the shafts running on ball bearings. Direct drive is obtained on third speed and an interlocking device is fitted in order to prevent more than one speed being engaged at the same time.

The rear axle is of the full floating type enclosed in a pressed-steel housing fitted beneath with a tension rod to maintain the alignment of the wheels. Ball bearings are employed throughout and the rear wheels are fitted with large-diameter brake drums on which two sets of brakes operate. External contacting shoes are operated by means of a pedal, while the internal expanding brakes are operated by a lever. It will be seen that the rods are supported on the torque tube and are entirely within the bounds of the chassis frame.

The front axle is an I-beam drop-forging, the pivot pins and knuckles being supported on ball bearings. The cross rods con-

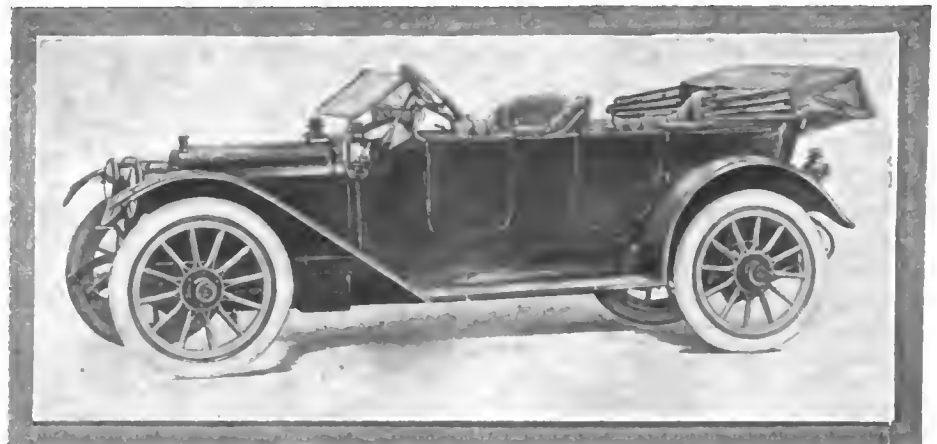

Fig. 2—Side view of the fore-door five-passenger touring body fitted to the Republic chassis

necting the steering arms are placed behind the axle and the connecting rod is over the axle, thereby being protected from any road obstructions. The front springs are semi-elliptic, 40 inches long and 3 inches wide, and the rear springs are three-quarter elliptic, 45 inches long and the same width as the front. The rear springs are mounted beneath the axle tube by means of drop forgings, thus permitting increased spring clearance.

The frame is made of pressed steel of U-section with five cross members, extra angle plates being fitted to the rear for the reception of the half springs. The steering is of the worm and sector type fitted with adjustable thrust bearings; an 18-inch steering wheel is provided. The wheel base of the car is 120

inches, while the tread is 56 inches. Artillery wheels with dished spokes are used and are fitted with 36 x 4-inch tires.

The price of the car with standard equipment is \$2,250, which includes top, speedometer, adjustable windshield, five lamps and gas tank. The standard touring car is shown in Figs. 1 and 2 and, as will be seen, sets low and is fitted with fore doors.

### New Three-Thousand Pound Wagon on Market

The new model L truck recently brought out by the Chase Motor Truck Co., of Syracuse, has a 30-horsepower motor. The motor is of the two-cycle type, having three cylinders, 4 1-2

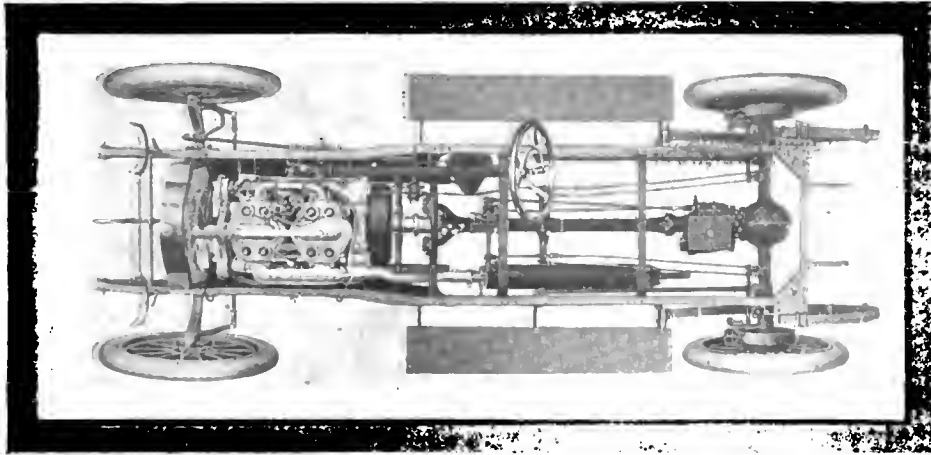

Fig. 3—Plan view of the Republic chassis, showing the general arrangement of the motor and the transmission located on the live rear axle

inches bore and 5 inches stroke. The motor is air-cooled and is equipped with a Holley carburetor, Bosch magneto and Brown-Lipe sliding gear transmission. The lubricating oil is supplied with the fuel passing through the carburetor into the cylinder, a method which has become common in two-cycle practice. The chassis sills are of selected ash and are 2 inches wide by 5 inches deep. The front wheels are 36 x 3 inches and the rear are 38 x 3 1-2 inches. The wheelbase is 112 inches and the tread 58 inches. The clutch is of the cone variety with cork inserts and the rear wheels are driven by separate chains, being equipped with emergency brake drums. The foot brake for ordinary occasions works on the jackshaft drums.

### Simplicity An Objective Point in 1912 Models

The three-ton truck listed as the 1912 model of the Rapid Motor Vehicle Co. of Pontiac, Mich., represents this concern's idea in producing a commercial vehicle which will be as simple and efficient as modern automobile practice will permit. The car has a straight line drive with universal bearings on the ends of the radii rods, which are concentric with the jackshafts and their housings. The engine, which is a four-cylinder, four-cycle vertical, water-cooled type, is controlled by a governor which is sealed at the speed at which the truck is supposed to run when the truck leaves the factory, and, although the setting may be changed, it is so arranged that it cannot be tampered with by a careless driver. The lubrication is by force-feed with separate leads to each cylinder and main bearing, with a return pump for the surplus oil; this precludes the possibility of flooding the cylinder with oil. The ignition is done by Bosch high-tension dual system, which is accessible from the left-hand side of the motor. The radiator is of the flat vertical tube design, of 12-gallon capacity and is suspended on either side by spiral springs which also absorb road shocks.

### Commer Truck on Missionary Trip

After having done the baggage carrying of the Chicago Motor Club at the recent Indianapolis races, a trip of 220 miles and

covered at 16 miles an hour, the Commer 3 1-2-ton truck has started on a long missionary tour. It is planned to visit the States of Michigan, Indiana, Ohio and New York, making stops at Cincinnati, Dayton, Springfield, Columbus, Toledo, Cleveland, Detroit, Buffalo, Rochester and all the other large cities along the route. At the last report the truck was well on its way towards New York. There is no desire to do this trip in record or limited time, as the main purpose of the trip is to make demonstrations and establish agencies throughout the territories the truck passes through. Probably one of the most beneficial results that will be obtained from this tour will be that derived from the careful daily tabulation of the figures that are being kept of the fuel and oil consumption. Other data is being gathered which should be of great value in many respects, as a road test such as this will bring out any existing weaknesses.

### New Electric Vehicle Co.

The Standard Electric Car Co., with its plant at Jackson, Mich., has been recently organized for the production of electric vehicles of medium price. The company announces that there will be no radical departure from standard practice in its designs, but that it will adhere strictly to the current ideas of electric vehicle practice. The car has a four-passenger coupé body, and is operated by means of a chain drive. The batteries used are optional and may be either of the Edison or lead type. The manufacturers are now establishing agencies in different localities and are very optimistic over the outlook during the coming season.

### Krueger to Make Electrics

SOUTH BEND, IND., Aug. 7—Clem F. Krueger, for seven years associated with the Studebaker Automobile Company, has been elected vice-president and general manager of the Standard Electric Car Company, of Jackson, Mich., an organization formed for the production of electric vehicles at a popular price.



One-ton Rapid truck that carries Oakland Motor Car Company's freight between Pontiac and Detroit



# New Things Among the Accessories

## License Plate on Front Axle

THERE may be some advantages in the attachment of the front number plate of a car to the axle in preference to the

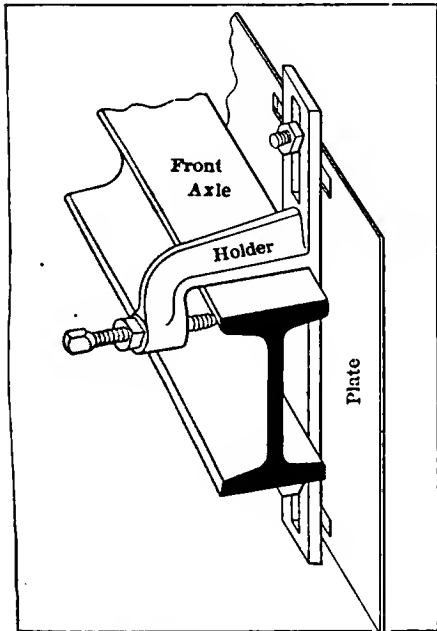

Fig. 1—Showing how the Apco plate holder is attached to the front axle

usual location on the radiator. First, because this latter arrangement covers up part of the valuable radiator surface, thus detracting from its cooling effect; second, because this method of fastening the plate to the car makes it impossible to prevent the plate from rattling, which means not only noise but depreciation as well.

As a departure from plate holders a novel construction, the Apco, is shown in Fig. 1, indicating simplicity and strength at the same time. It is made of bronze, and is fastened to the plate through the four slots by means of screws and nuts, while two bolts serve to press that part of the holder, which bears against the number plate, against the two flanges of the I-section axle. A locknut on the bolt keeps it under pressure for a long time and prevents lost motion to creep in at this place.

The Auto Parts Company, of Providence, R. I., furnish the holder, together with all the screws, bolts, nuts and lock washers for a very low price.

## Fix Tire Cement

CEMENTING damaged tires is an important sort of repair work, and a mixture which will contain all the necessary

ingredients and after having been applied dries in the minimum of time will be found useful by practically all automobilists. Fix Tire, which comes in paste form and is contained in tins, may be used to repair blow-outs, punctures and cuts of tires and other articles made of rubber, such as hose, blankets, boots, etc. It is made by the Motor Accessories Makers, 80 Jackson Boulevard, Chicago, Ill.

## Spring Ball Throttle Connection

THE construction of a free and secure joint of small dimensions will be considered an easy task by many, but undoubtedly it is not the easiest that can be thought of. Such a connection is needed in more than one place on the automobile, for instance, on the spark control and the carbureter adjusting rod, and because of the importance and peculiar character of these parts the ball and socket ought to be strong without lacking in sensitiveness. As may be

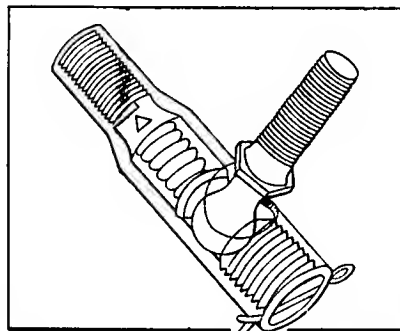

Fig. 2—Free and secure B. & S. spring ball and socket joint

seen in Fig. 2, the connection consists of a cylinder which in its two sections holds the socket. One of the sections contains a spring insuring tension of the socket against the ball, while in the other section is seen a plug, screwed into the cylinder and held in place through the office of a

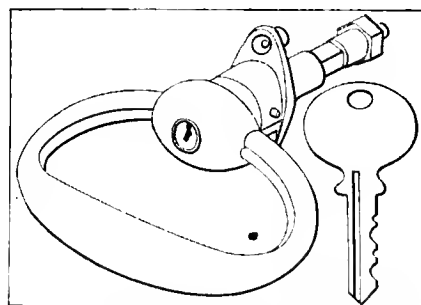

Fig. 3—Security handle for locking the tonneau with a Yale key

cotter pin. This arrangement insures an efficient connection while the ball end of the joint is allowed a sufficient amount of play. This connection is made by the Billings & Spencer Co., of Hartford, Conn.

## Locking Handle for the Tonneau

BURGLARS, however daring, are a comfort-loving lot, and, considering a great number of burglary accounts as they appear in the daily papers of this age, it seems that they prefer entering a building, especially a private house, by way of the groundfloor windows rather than through one in the upper stories. Some automobile owners there are who would readily place the joy rider in one class with the real criminals above mentioned, but this is undoubtedly an exaggerated idea. Still, increasing the difficulty for joy riders to enter the tonneau will keep out a good many of them if not all.

The solution of the problem lies in the singular construction of the Security Locking Handle, which is herewith illustrated, showing a Yale lock in the outside end of its spindle which keeps the handle in the "closed" position at all times except when it is turned out of this position by means of the special Yale key. When the key is not in the lock, and the door of the tonneau closed, it is securely locked after a button in the handle collar is pressed in. Afterwards, when the lock has been opened with the key and the passenger entered the car, he locks the door by pressing a button in the inside end of the shank.

The Security handle is made in several types and easily installed on a car, fitting all locks used in closed work. It is not necessary to cut away of the wood pillar in installing the handle, nor is its installation an expensive matter to undertake. It is made by C. Cowles & Co., New Haven, Conn.

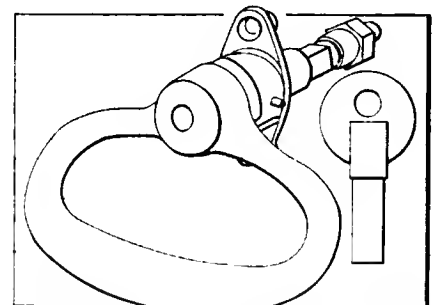

Fig. 4—Another type of the handle with different construction of lock

## Seen in the Show Window

**H**IGH engine efficiency is due, to a great extent, to thorough carburation of the incoming air, and the flexibility of the motor also largely depends on this condition. According to the makers of the Homo carbureter (BO) a very desirable state of homogeneousness of mixture is obtained through the use of the Homo, a small wheel having propeller blades and being placed in the way of the mixture flowing to the engine. As the illustration indicates, the motor suction lifts the throttle T to the necessary and correct degree, while the gasoline coming from the float chamber F is atomized by passing through nozzle N into the mixing chamber M. Thence the charge is drawn through the Homo wheel, where it is completely diffused, to the engine cylinders. The Gasoline Motor Efficiency Company, of Jersey City, N. J., is the maker of this carbureter.

**W**HHEELS, for some forty centuries or so, have been made with the rims rigidly fastened to them, and it remained for the automobile era to develop the demountable rim and demonstrate its advantages. As one type of demountables the Denegre rim is here shown (BP). On its inside this rim has thirteen fasteners having tongues. The wheel rim, too, has thirteen fasteners on its outer surface, and the fasteners are grooved to engage with the tongues of the tire rim fasteners. A key fits in the opening of the wheel rim, and after the tire rim with the inflated pneumatic has been put in place the key is secured in the opening and tightened by the only bolt which is used on this rim. It is the product of the Denegre Demountable Rim Company, of 1922 Avenue F, Birmingham, Ala.

**E**VERY automobilist may not be in favor of stringent legislation, but laws must be obeyed as long as they are in force, and to conform with the law the autoist who wishes to keep out of trouble will keep the tail lamp of his car illuminated after the sun has vanished beyond the horizon. Of course, the tail light, which is not intended to compete with the searchlight on the front of the car, but, rather, with the fireflies of the open country, need not be an acetylene light, but a modest oil flame will in most cases suffice to make the number of the rear plate legible. The tail lamp shown at BQ is handled by the Gus Balzer Company, whose office is at 1777 Broadway, New York City.

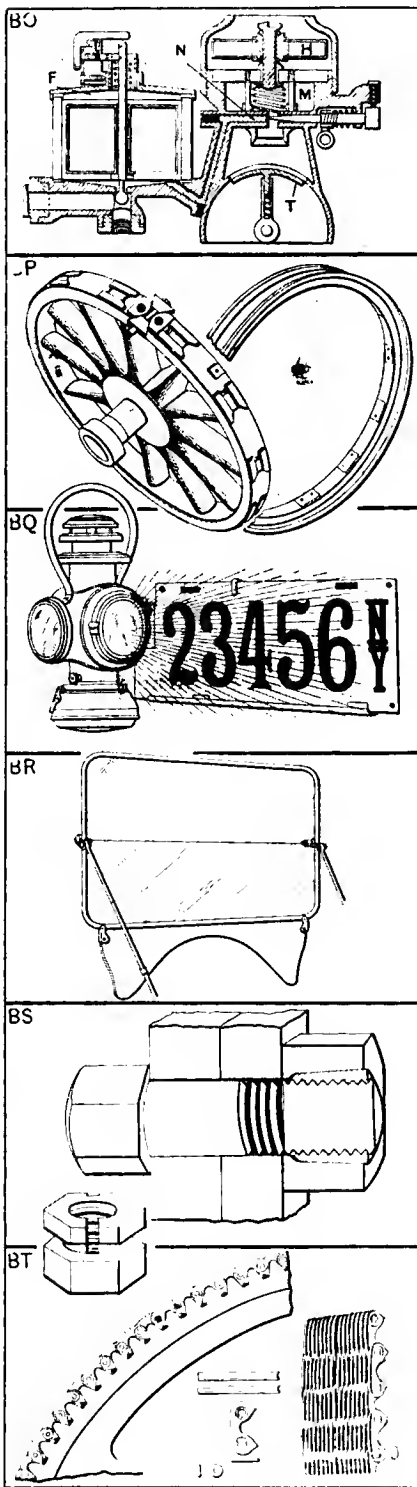

BO—Section through the Homo type of carbureter  
 BP—Denegre demountable rim and wheel felloe  
 BQ—Gus Balzer tail lamp for license number plates  
 BR—Vision automatic windshield without metal division  
 BS—Columbia nut on bolt and improved form of nut  
 BT—Link-Belt silent chain and details of construction

**Y**EAR by year automobile builders find ways and means of increasing the comfort of the people who are to ride in the cars made at their factories. Considering only one small portion of this field, it will be remembered that windshields protecting the passengers from the strong air currents, and moreover, inclement weather in certain seasons, are a comparatively novel part of the motor car but one which makes for much comfort. The Clear Vision Automatic Windshield (BR), which is made by the Sprague Umbrella Company, Norwalk, Ohio, has no division strip to obstruct the driver's view, but the two glass plates come in direct contact when the windshield is put up in position, in which it is locked automatically. The material is French polished-edge plate glass.

**S**IMPLICITY, strength, correct size and accessibility are the chief requirements of lock nuts. Material and labor used in their production must be of quality if the properties enumerated above are to be found in the product, and as an example of the results along this line of effort the product of the Columbia Nut & Bolt Company, of Bridgeport, Conn., is illustrated at BS. The small nut shown in the cut is of the "Improved" type, which has a double castellation, thus permitting of a stronger hold of the wrench upon the nut.

**Z**EAL of the kind that never tires has made considerable progress in rendering the automobile of to-day a silent performer, and while one army of engineers is occupied with the work of devising silent-moving parts for the power plant, the silent transmission of the motive power to the rear wheels is being developed by another set of workers in the field. In the transmission of the power from the jackshafts to the rear axle considerable measure of silence may be obtained by the use of the "Maximum" Silent Chain, which is shown at BT, where the manner of driving the chain from a sprocket is illustrated. The same illustration shows a side view of some of the chain links, each link consisting of more than a dozen steel plates connected up in parallel and held together through the office of a set of strong bolts and nuts. Returning to the sprockets which the chain connects, they are so constructed as to take up the links during the drive with practically no lost motion, the chief reason of noise in power transmission. The Link Belt Company, of Philadelphia, Pa., manufactures this drive chain.



# THE AUTOMOBILE

## Jersey's Chinese Wall Finished

### From Heap-Bunk to Top-Sleep It Is Complete

Counterpart of the Great Wall of China, erected by the State of New Jersey to prevent an invasion of American foreigners in automobiles, is finally finished and the last loop-hole, the eight-day touring license, has been abolished. From now on the good roads of Jersey will be almost wholly used by residents, and civilization, as expressed in the development of transportation, will take a backward step. Horse-drawn traffic seems to be unduly emphasized in comparison with its importance and automobiling within the State has received a set-back.

AFTER Quing Wong Duck (or whatever the name of the last Chinese Emperor of the Ming dynasty may have been) completed the Chinese Wall and had it inspected he stood back and said that his work was one of the wonders of the world. Since then succeeding generations have pronounced King Duck's judgment excellent.

After the Jersey Legislature had enacted the Frelinghuysen bill into law, and later modified the law so that Motor Vehicle Commissioner J. B. R. Smith had it in his power to wipe out the eight-day touring privileges, all those interested are given the opportunity now to stand back and pronounce the work another wonder of the world.



JERSEY'S AUTOMOBILE LAWS HAVE ERECTED A VERITABLE CHINESE WALL ABOUT THAT STATE—THE MAN WHO IS ADMINISTERING THEM

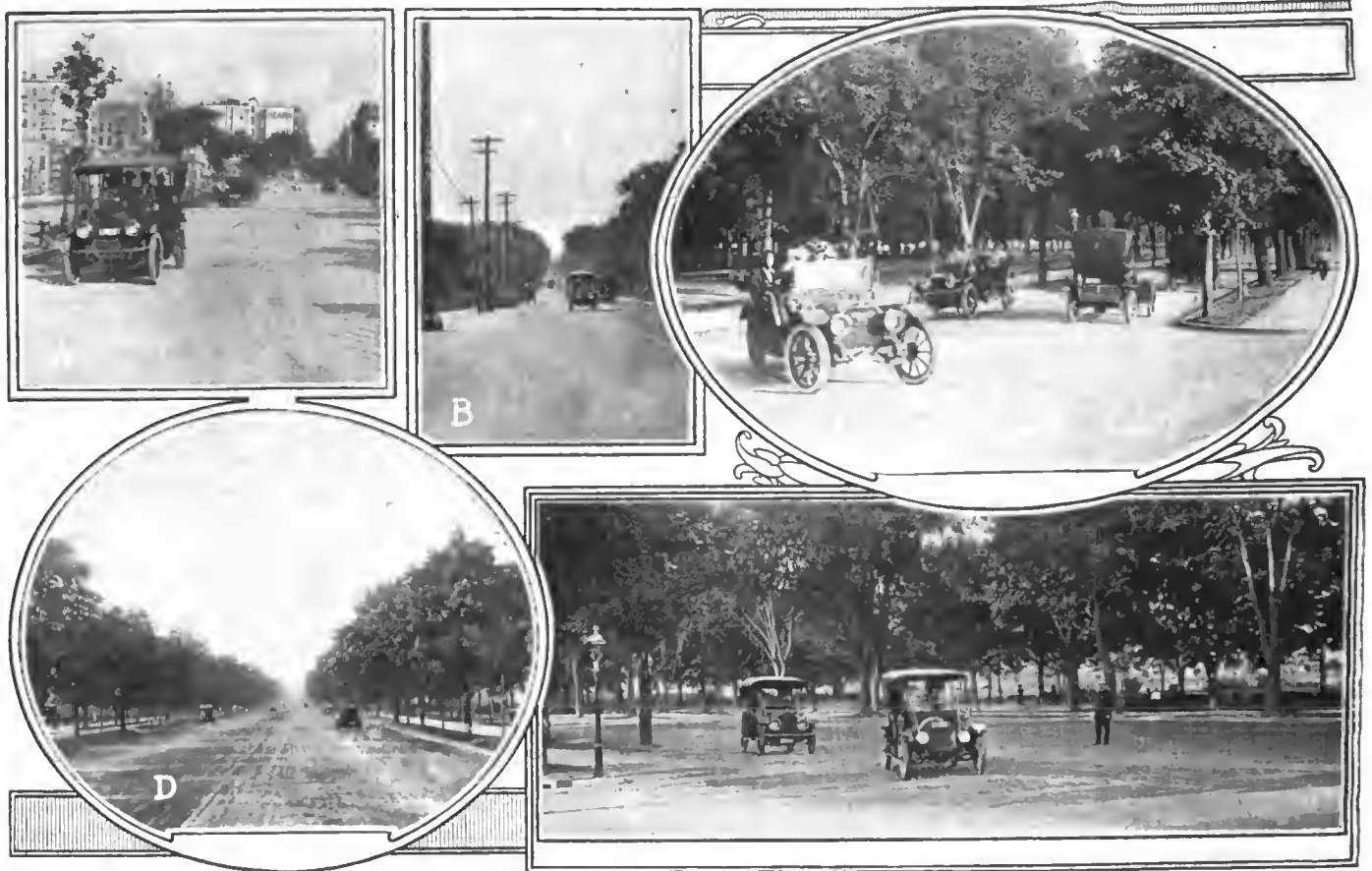

A—Between 5th and 6th avenues, New York, looking along 110th street, showing automobile activity  
 B—A steady stream of cars pass out of New York in the direction of Yonkers  
 C—Some of the cars that form a constant flow from New York to the Long Island beaches  
 D—The boulevard as can be seen in this picture is bristling with automobiles  
 E—The speedway being interdicted to automobile traffic. Automobiles are compelled to make a detour

Both walls were built with the same object in view—namely to foil invaders. The Chinese wall was constructed westward from the Gulf of Pe-Chi-Li along the northern boundary of the empire and when it was finished it measured 1,250 miles in length. It is still 35 feet high and 21 feet wide in long stretches and has watch towers scattered along its whole extent at varying intervals.

The New Jersey Chinese wall extends from Jersey City-Foo Chow, northward nearly to Tappan-Chung and then westward to Port Jervis-Quong Ding and then south through Delaware Water Gap-Ping Bung and east of Philadelphia-Top Sleep to the southwestern corner of New Jersey-Shan Tung to Cape May and north along the Atlantic Ocean through Atlantic City-Heap-Bunk, to Jersey City-Foo Chow again. The wall is a million feet high and half a million feet thick, or at least such an estimate has been placed upon its dimensions by certain New York, Pennsylvania, Delaware and Massachusetts automobilists who have been brought into contact with it.

The Chinese Wall was built because the Chinese believed they had such a fine country that the savage hordes on the north coveted it and sought to plunder it, but the reason for the Jersey wall is two-fold. In the first place Jerseyites have had an extraordinarily good opinion of Jersey roads. They have little else to be proud of in a public-spirited way and consequently they emphasize the beauties of their roads. In fact they think so well of them that they do not want foreigners (*i. e.*, Americans) to enjoy them. Secondly, if the aforesaid foreigners insist on enjoying the roads, why not turn an honest penny?

In times past rapacious country constables and venal peace officers made handsome profits from levying fines for alleged violations of the law. Frequently these fines were paid on the spot, thus relieving the "offender" of the necessity of attending

court, and possessing numerous advantages, financial and otherwise, for the constables and others. This became so flagrant after awhile that the State suddenly realized that it was overlooking something good and then the present law was passed.

Under this law power was delegated to the Motor Vehicle Commissioner to enforce the law which requires a full season's license from every foreign and native, without benefit of clergy.

One little mitigating circumstance was inserted in the law, which provided for a limited touring license within the sacred precincts, if similar provision had been written into the State law of another State with regard to Jersey citizens. This limited license cost \$1 and was good for eight days' riding. Under all the circumstances, eight days in Jersey ought to be enough for any "foreigner" and the arrangement worked fairly well for a while.

Then Commissioner Smith discovered that New York, Massachusetts and Pennsylvania, while opening their magnificent highways to each other, would not have anything to do with Jersey on that basis. The attitude of Jersey in demanding its ounce of flesh from every tourist was called by various unpleasant names, the least offensive of which was "pea-eyed infinitesimal."

New York's grand highway system was open to the Quaker brethren and Massachusetts freely welcomed both families, but as Jersey wanted its dollar a head from every "foreigner" under the most favorable circumstances and a full year's license whenever possible, the doors were slammed against the "thrifty" little commonwealth which lies at the south end of the New York and Philadelphia drainage systems.

Then Commissioner Smith, by virtue of the power which has been construed to reside in him, decided to call in the eight-day licenses or at least to issue no more to the citizens of the "foreign" States and the last loop-hole in the great Jersey



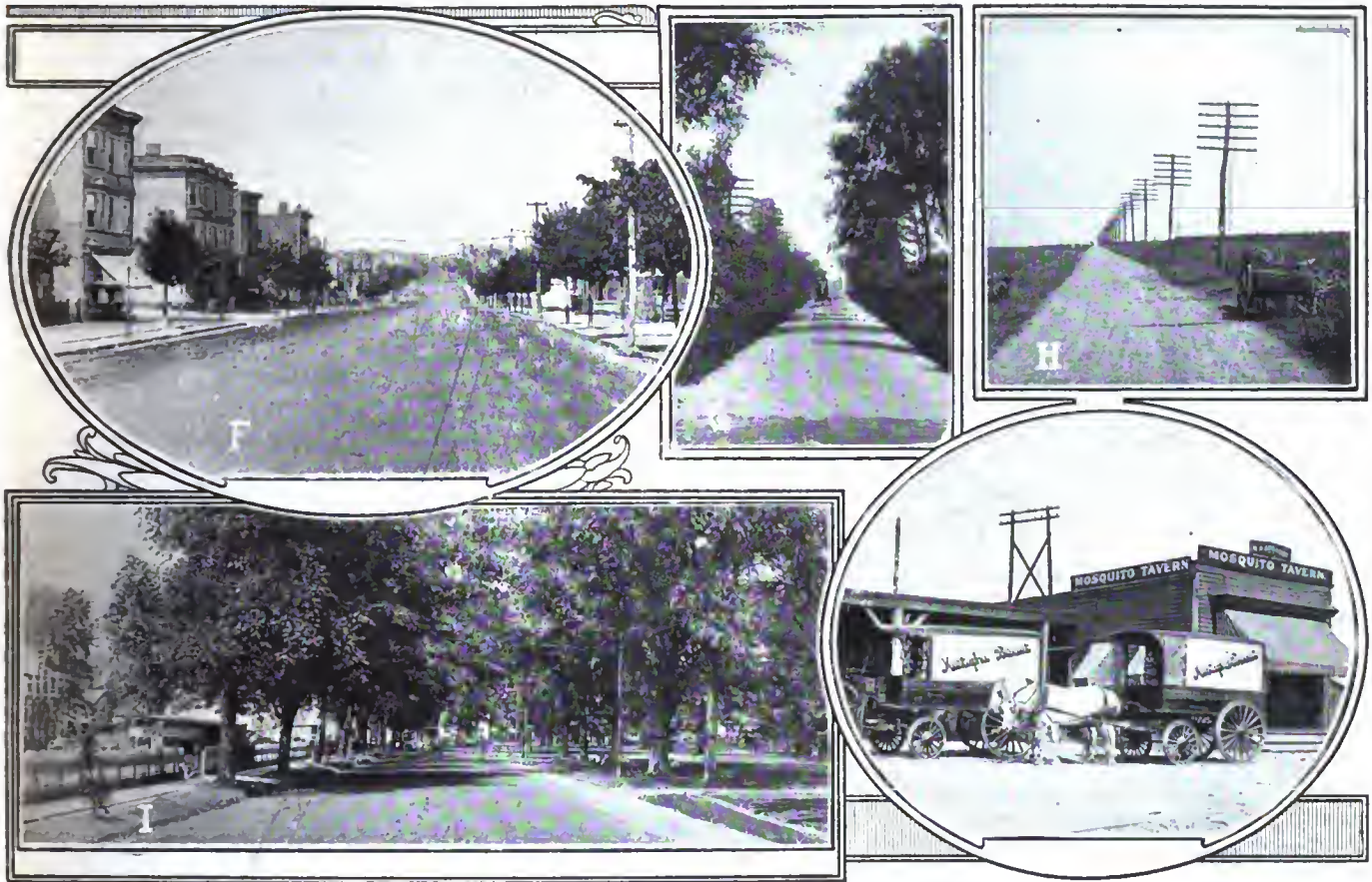

F—This shows the deserted state of the Hudson County Boulevard, a magnificent Jersey highway

G—Jersey possesses some beautiful roads, where the horse can go unmolested

H—The turnpike across the marshes is like the Deserted Village

I—Village streets are covered with leafy bowers, but automobiles are conspicuous by their absence

J—Mosquito Tavern, a pull-up for wagonmen, offers little inducements to automobiles

Chinese Wall was plugged up from the inside and clinched from the outside.

Aside from the fact that all interstate legislation touching automobile traffic is unconstitutional, invalid and void, and will so be pronounced eventually, the situation that has developed is miserable from every point of view.

New Jersey has a large number of automobiles, many of the owners of which have business in New York, Philadelphia and elsewhere. It costs a material sum for the native of New York to gain official sanction from his home State to operate his automobile, and the same may be said for Pennsylvania and residents of other States. But it does not cost the Pennsylvanian a cent to motor in New York if he is in good standing at home, because the Pennsylvania law allows New Yorkers to use the Pennsylvania roads if they have satisfied the legal requirements at home.

Thus, while it only costs the Jerseyman, say, \$10 a year for license to operate his car within the State, it costs him dear if he tries to escape. One plunge into New York means a full year's fee: one little slip into Pennsylvania calls for the entire face value of a yearly license and if after making these two excursions the Jerseyman trundles into Massachusetts he is set back for a yearly touring license which will be graciously issued at a price, on behalf of the Old Bay State.

When he gets out of his own bailiwick his Jersey license marks him as fair prey. Everybody knows what happens to one in Jersey under the same circumstances and as a means of reprisal, knowing that the Jerseyman would reverse the positions if he had the power, the "foreigner" plucks him to the bone, without a pang of conscience.

It costs the citizen of Jersey every time he ventures into untried territory and it costs the "foreigner" who invades Jersey.

But that is all as far as the "foreigner" is concerned. No other State demands its pound of flesh and gets its ounce except Jersey.

The result is now becoming painfully apparent. Jersey is declining as a touring ground for "foreigners." The magnificent roads are slowly being pecked to pieces by horse traffic and automobiles from outside are growing less and less in value. Automobileists call emphatically to the Touring Club of America and the *Blue Book* for routing directions that will bring them to certain objective points in the South and West without touching Jersey and such information is cheerfully furnished.

In order to show that the attitude of Jersey is deliberate about this matter it may be cited that at the last session of the Legislature one of the solons in contesting the reasonable measure that was being considered said: "This bill must not become a law, because if it is enacted, throwing the State open to automobile touring, our roads will be lined with cars and cannot be used with comfort by our own people."

If such a result could be accomplished by the passage of a law opening the State, it would not hurt the feelings of hotel proprietors, restaurant keepers, garage men, real estate owners who appreciate an advancing market or business men in general who like the idea of plenty of outside money as a motive force for inside business. But far and away the most pleased section of Jersey citizenship would be the dealers in automobiles.

Every little obstacle in the way of pleasurable use of the car limits the market for more cars and when such an obstacle as the Jersey Chinese wall is interposed, the deleterious effect must be felt widely in the course of time. The accompanying pictures illustrate a few of Jersey's fine roads and as they were taken at a time of day when the roads might well be covered with traffic, the absence of automobiles indicates that the wheels of progress have been checked. On the other hand, in the illustrations

pictured on Long Island and in other spots outside of the "Wall" the presence of traffic shows that something must be the matter with the Jersey territory.

The law hampers traffic and consequently is bad for business as well as being oppressive to citizens of Jersey and to Americans.

Now the real reason for complaint against the "Wall" is, of course, to a certain extent founded upon the mulcting of automobilists for a money fine, as if there was something criminal in the operation of a car *per se*, but the greater portion of the objections raised do not take the mere money into consideration at all. The chief "beauty" about the Frelinghuysen law is the fact that after the American "foreigner" has paid his yearly license to tour one day in Jersey he must acknowledge that he is incompetent before the law if not actually criminal by signing a power of attorney empowering the Secretary of State to accept legal service in his behalf in case the peace officers or others shall suspect him of violating the law.

If the solons had gone one step further and made the power of attorney broad enough so that the Secretary of State or the Commissioner of Motor Vehicles or someone else could not only accept service but also enter a plea of guilty on behalf of the American in a criminal action or to confess judgment for him in the civil courts the intent of the solons would have been better served.

The legal attitude of the State of New Jersey is an anachronism. It harks back to another age—an age when savage tribes held mountain passes between populous centers and exacted toll from every passer on the highway. There is a disregard of ethics, gentility and fairness in the attitude, but as in all other situations of the kind recorded in history, it must work its greatest harm upon itself. The advantages of quick transit are too thoroughly understood to require argument. The history of transportation is the history of civilization and the automobile is the highest light in the bright pages.

Whatever is done to check transportation and easy communication tends to destroy civilization and points toward chaos.

Jersey has taken a step in that direction in attempting by law to make the use of the automobile unsatisfactory.

Ordinarily the pleasure automobile is used for its owner's enjoyment. Too frequently he cares nothing what its operation costs and is careless about all the various items of expense that go to make up the grand total. There are hundreds of automobile owners in New York who pay all their automobile bills without giving them the critical analysis that they would if the bills represented some element of a business transaction. The \$10, or whatever it is, that it costs for a Jersey license would not be considered for a second as an obstacle to the enjoyment of the automobile owner and yet this autumn will see fewer New York, Pennsylvania and Massachusetts automobiles in Jersey than any year since 1907.

Surely this is not because the owners of the cars balk at the idea of spending \$10 more. The fact of the matter is that they will not take out Jersey licenses because they cannot do so and



K—Automobile activity along one of the roads leading out of New York

maintain their self-respect. They feel that they do not wish to be hampered territorially, but they will not knowingly and willingly class themselves with ticket-of-leave men, ex-convicts, habitual criminals, etc., by giving up any of their rights before the law in order to have the privilege of paying to tour in Jersey.

They figure that the law stands on the statute books and if they evade it or break it, they are amenable to its penalties and consequently they cannot see why they should hand over the legal right of personal service to an officer of New Jersey, while at the same time the resident of the State is only deemed to be guilty of any crime after due service and conviction in a competent court. Under the nauseous and un-American "Power of Attorney" clause, judgment by default could be entered by a court against a non-resident after the Secretary of State had accepted service in the case, providing the non-resident was not represented in court.

Suppose that a tourist was charged with exceeding the speed laws, or carrying two licenses, or breaking some traffic regulation by some officer in Jersey. Suppose that the alleged crime or misdemeanor was not noticed by the occupants of the car and the officer complaining of the breach of the law was not seen by any member of the party. It is perfectly possible that after the constable has made his complaint and legal service accepted by the Secretary of State that the case should come on for trial without the slightest knowledge of it having reached the defendant. Suppose that the party continues its way out of the State and tours indefinitely through the South, for instance. Upon his return to New York it is conceivable that the owner might discover that during his absence the limit penalty of the law had been imposed upon him. Of course, that would be an extreme case, but there is nothing impossible about it.

A staff representative of THE AUTOMOBILE and a photographer made a tour over a number of typical Jersey roads recently in quest of illustrations for this article and considerable care was exercised in getting accurate pictures showing actual conditions.



L—The surface of the Yonkers road has been worn smooth by automobile tires

The trip was made on a week-day between the hours of 2 and 6 o'clock on a pleasant afternoon. The paucity of automobiles was painfully noticeable throughout the trip, as will be noted from an examination of the pictures.

The direct opposite is shown in the pictures taken in and around New York, where every street has cars upon it almost every hour in the day. It costs Americans considerable money to avoid New Jersey and considerable chagrin to think that they are barred from the "sacred precincts," but it costs the Jerseyites much more in money and loss of trade and conditions are gradually developing that will bring these facts keenly to the notice of the Jersey citizen who does not want foreign automobiles to use his roads.

The automobile manufacturing business with its accessory branches and allied interests ranks third in the United States in value. It is growing each season and will continue to grow, according to all indications. This industry was not raised upon

such laws as that which disgraces the statute books of the Jersey commonwealth. Such laws are a detriment to the automobile business and consequently to transportation, which means civilization.

There is little comfort to be derived from contemplating the immediate legal future in Jersey, but the life of the present situation must prove short. There are a lot of excellent Americans living in the State. They are not fond of the status of affairs and in the end they will win and the great "Wall" will be shot as full of holes as is its counterpart on the north line of the Flowery Kingdom.

They really represent the American spirit of Jersey and despite the fact that they have not succeeded in abolishing the Frelinghuysen law to date, they earnestly oppose it and if intentions ever forecast action the law will be torn from the books the next time the people of the State have an opportunity to voice their wishes.



M—A view of one of the Jersey main roads with its trolley cars and wagons

## Mud-Splashing Omnibuses

*The nuisance has become so aggravating on the streets of London that the matter has come up in Parliament. It is proposed to scotch the evil by compelling the 'bus companies to equip their vehicles with mud-guards.*

THE question of mud-splashing by motor buses in London has become so pertinent that it has got into Parliament, where no less a personage than the Home Secretary, Mr. Churchill, has taken a hand in the matter. So aggravating had the nuisance



N—This fine stretch leading from New York into Jersey is given over almost entirely to horse-drawn vehicles

become, that a meeting of London representative bodies was held at Stratford, as a protest. This conference, "representing twenty-one local authorities in Greater London," having become cognizant of the serious damage and annoyance to persons and property caused by the mud splashed from the wheels of motor omnibuses, "and having regard to the refusal of the Commissioner of Police to take reasonable steps to obtain an abatement of the nuisance," called upon the Home Secretary to intervene and to require the Commissioner of Police to make it a condition of his license that all motor omnibuses plying within the limits of his jurisdiction should be fitted with mud guards.

To all of this, the Home Secretary replied that the reason the Commissioner had not made the regulation insisting on the use of some form of mudguard which would prevent the nuisance was that, in spite of inquiry, inspection and actual trials, no mudguard had been found which did not entail serious disadvantages and danger. Therefore, he said, "I could not ask the Commissioner to enforce the use of special mudguards till a suitable type is invented." Meanwhile, the motor omnibuses go on splashing mud and the representatives of the twenty-one local authorities in Greater London continue to fume and protest.

CARELESS USE OF COTTON WASTE—The interior of enclosed bearings should never be cleaned with cotton waste just before they are finally assembled. Small particles of the waste are apt to be picked up by the oil and carried to a spot where they will effectually clog the oiling system.

# New England Hills Free from Heat

## Tour of the White Mountains Attractive

*When a change from city or seashore is desired, the automobilist can enjoy the lake country, forest and mountains with a minimum of bother and preparation. One of the most delightful tours possible to take in this section of the country is the two-day run across the White and Green Mountains, passing the celebrated Bretton Woods high in the hills. The scenery is far and away the finest in New England, and many consider it a rival of the Alps.*

MAINE, New Hampshire, Vermont and Northern New York are particularly attractive at this time of the year to automobilists, and a trip through the White, Green and Adirondack Mountains holds out compelling charms during

the vacation season. When those who may be summering on the Maine coast feel the slackening of interest in the sea and the rocky headlands and the desire to move and see something else becomes a conscious thought, the following suggestion for an automobile tour may strike a responsive chord.

A leisurely run of two days, which may be extended into three or four as fancy dictates, through the Maine forests, across New Hampshire and Vermont to Lake Champlain and as much further as the party wishes affords an opportunity to enjoy the scenery in New England in perfect comfort as regards excessive heat.

Even an ordinary car can negotiate the grades with ease and maintain a running schedule that will be satisfactory. Aside from comfortable underclothing and waterproofs, no special equipment is required for the trip through the mountains.

Starting from Portland via the direct route, which is Route



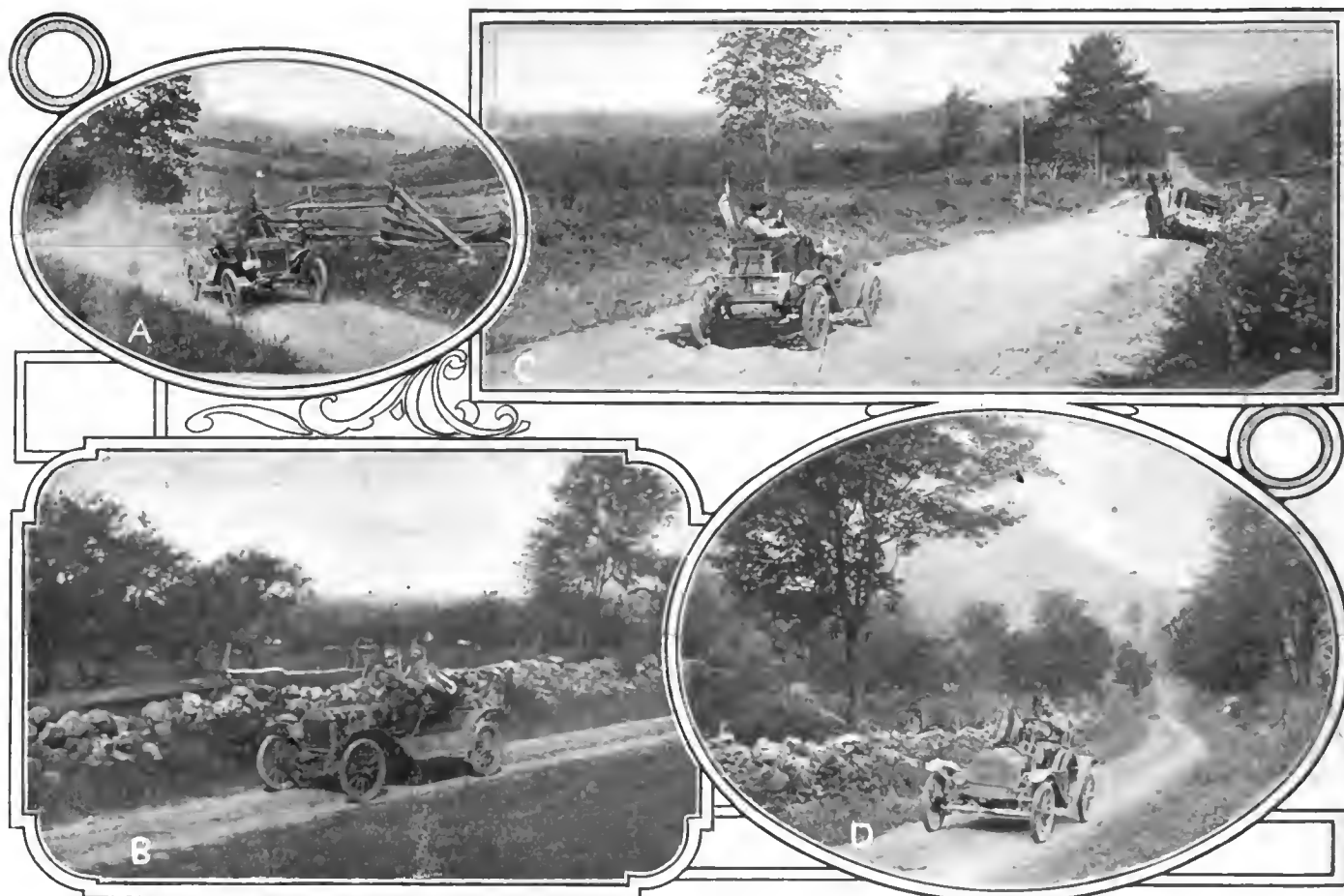

A—Leaving Montpelier on the last climb of the second day  
B—Striking north from the city of Portland, Me.

C—Bethlehem in the highlands of the White Mountains  
D—Between the White and Green Mountain ranges

611 of Volume 2 of the *Blue Book*, the road trends northwest, crossing the Presumscot River at Riverton and then skirting Duck Pond on the right, getting a glimpse of Sebago Lake after passing North Windham. Running along the shore of this wonderfully beautiful lake the course passes Naples and then follows the shore of Long Lake to Bridgeton. The main villages and towns passed on this route between Portland and Bridgeton are Morrills Corners, North Windham, Raymond, South Casco, Naples and Bridgeton. The mileage is 39.2 through typical Maine surroundings.

Every few miles a wonderful lake scene is spread before the eyes with its setting of rugged hills and every gradation of green that the forest is capable of producing. From Bridgeton the way leads to East Fryeburg and then Fryeburg, where the foothills of the White Mountains begin to loom up like an impassable barrier to the progress of the car. Just beyond is the State line of New Hampshire at East Conway and at North Conway the route joins Route 403. The mileage thus far is 64.8 and makes just a nice, comfortable all-the-morning run.

Luncheon may be taken at Intervale, a couple of miles further along the way, and after a mid-day rest the remainder of the day's run may be made with ease to Bretton Woods. The road follows a northerly course and swings westward after passing Lower Bartlett.

Winding south and then west the road passes Bartlett and continuing west enters the rugged hills. At Sawyer's River the road turns north and climbs past Bemis, Carrigan and Wiley's to the Crawford House. The feature of the day is the passage of Crawford's Notch, a natural gorge through the mountains, that has an interesting legendary history.

It is recorded locally that prior to the Revolutionary War a pioneer named Crawford carried the mails into the little-known Northwest and that he was offered a big land grant if he could

lay out a mail route that would shorten the distance between the seaboard and Quebec. Crawford while hunting in the highlands happened to lose his horse and in climbing a tree to get his bearing saw the notch-like groove in the crest of the mountains that seemed to afford the possibility he sought. He did not pass over the notch at that time and the war coming on prevented him from pursuing his explorations until after peace had been secured. Then he received a renewal of the offer by the Government and the test was to be his ability to lead a horse across the mountains. Crawford did this, according to the historians, and won the land grant.

To-day the rigors of the notch have been much ameliorated by road improvements and the cutting down of some of the stiffest grades. From Crawford's the way is through a wild and interesting country to Bretton Woods, where the night stop may be made at either of several creditable hotels. The Mount Washington House, facing toward the giant peak of the range and housing among other conveniences for the automobilists a branch of the Touring Club of America, is a magnificent stopping place, although there are a number of others excellent in every respect.

The day's run by this route is 95.2 miles and is altogether desirable from every point of view. The roads are frequently based upon gravel and well maintained, while in the main they are of dirt, but really rank high in that classification. There are some long steep grades, but they are not excessive and with due care there is no room for fear of mishap.

The second day's trip is via Route 477 to St. Johnsbury, Vt., passing along the Ammonoosuc River and various big resort hotels to Bethlehem and then Littleton. Thence through Waterford, crossing the Connecticut River, the road reaches St. Johnsbury, 37.6 miles across the western foot hills of the White Mountains and entering the ascent of the Green Mountain range. It may be well to take it slowly and enjoy this short run, for there

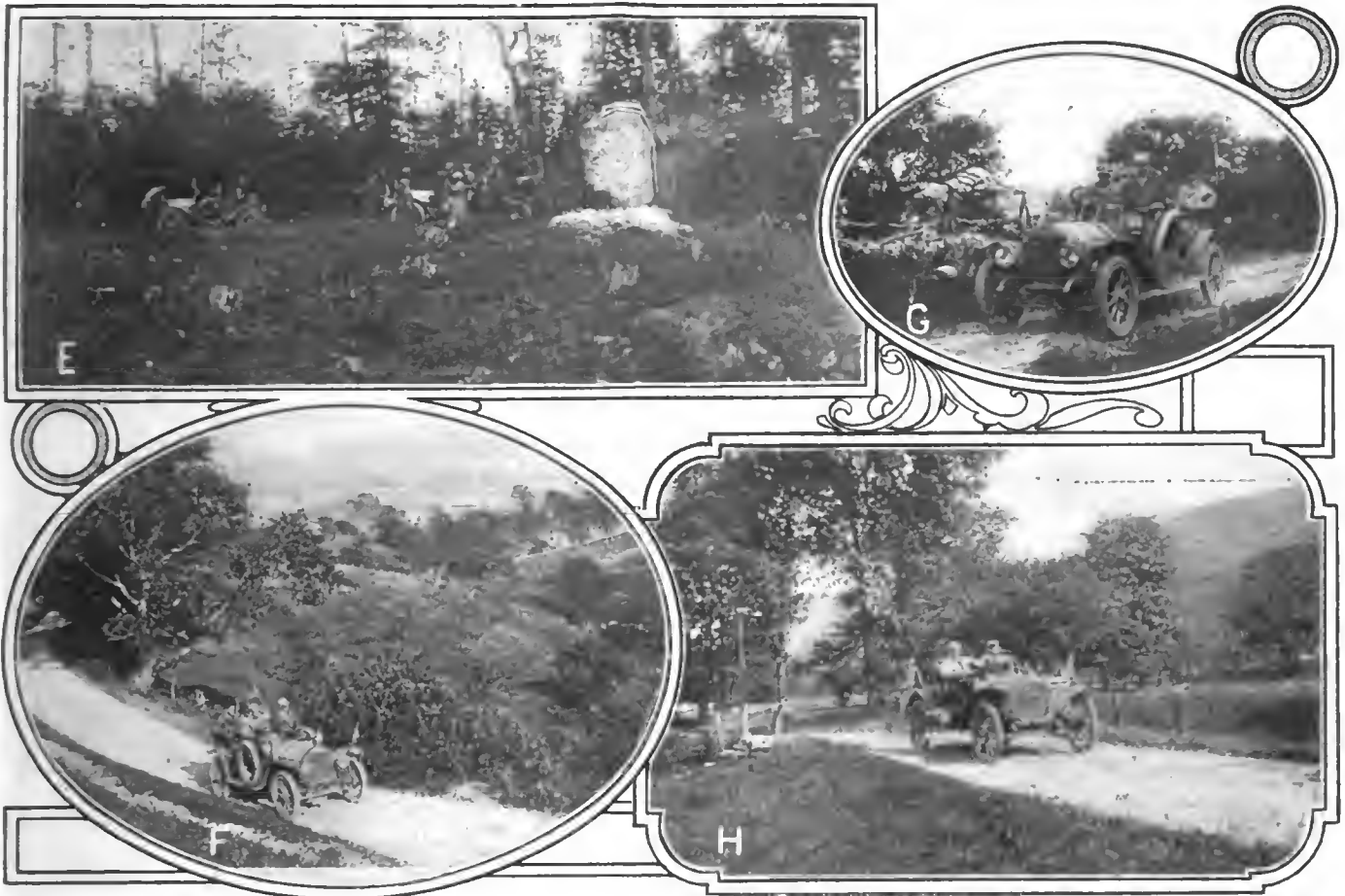

E—Lowell's Mount, near Fryeburg, Me.  
F—Where the Green Mountains smile near Burlington, Vt.

G—Just before the road winds away in Bretton Woods, N. H.  
H—Just before crossing the New Hampshire State line

is little in New England that equals this region in scenic beauty. Route 591 is the accepted way from St. Johnsbury to Burlington and it leads through a country of much charm scenically and much interest historically. The White Mountains have a distinctive, ghostly white aspect viewed at a distance, especially in the twilight, but the hills to the west are as green as verdure even when the searching rays of the sun are glaring upon them. The reason lies in the coloration of the rock in each case. In the White Mountains there is probably an element of limestone that shines white, while the granite of the Green Mountains lends that range its characteristic hue. The tourist will search in vain for a reason for this difference if he confines his investigation to vegetation.

Passing Danville, after steep down and up grades, the road touches West Danville, South Cabot, Marshfield, Plainfield and into Montpelier, the State capital. There is a winding, picturesque road from Montpelier to Waterbury and a few miles further on there is a 15 per cent. hill, which fortunately is short. Reaching Jonesville, the road is up and down to Richmond and after passing that place the way is mostly up until the crest of French's Hill is reached. Looking back over the road and across the valley the view from the hill top is superb. From there to Williston and into Burlington the route is comparatively easy.

The mileage from St. Johnsbury to Burlington is 78.4 and a good five hours will not be wasted in traversing it. If the start from Bretton Woods is made at 9 o'clock in the morning and at least three hours spent in reaching St. Johnsbury, where an hour at most should be spent in refilling with gasoline and oil and getting luncheon, the way to Burlington may be taken up at 1 o'clock and by 6 o'clock the day's journey will be finished.

Such a trip will be memorable. It is like nothing else in this part of the land and for varied beauty and interest rivals any-

thing in the world. The sight of the Vermont valleys from the tops of the mountains is poetically lovely and the roads are not bad, especially in dry weather. There are a few stretches of sand and heavy going, but in the main the going will be found to be fair where it is not better.

All told the day's journey is 116 miles long and at least eight hours of running should be used in making it.

From Burlington there is a choice of numerous interesting routes, particularly the tour to Canada, the one to the north end of Lake Champlain and down the New York side past Plattsburg to Saratoga or to Ticonderoga and thence westward.

### Difficulties Attending Exportation

*The difficulty of obtaining spare parts without an enormous delay and at great expense proves a great barrier to foreign automobile trade. It would take a number of sales to make it profitable to maintain well-stocked agencies.*

AMERICAN motor cars are not known in Frankfort-on-the-Main, Germany, and dealers do not care to take them up, as they consider it practically impossible, under existing circumstances, to work up a profitable business in handling them. In the first place, the various large German concerns can deliver excellent cars at prices which make foreign competition difficult. German manufacturers have a firm hold on the market and, with the exception of a few French machines, no foreign cars are sold or seen there.

In order to sell American motor cars there it would be necessary to keep up a stock either at Frankfort or some accessible point, where parts could be secured at short notice and where cars could be repaired.

# The New Warren-Detroit Models

## Describing Their Mechanical Features

In addition to the Warren "30" manufactured by the Warren Motor Co., of Detroit, Mich., two new models have been placed on the market by this concern. The "30" will in future be known as the "12-30," the two new models being respectively designated as "12-35" and "12-40." No material alteration has been made in the design of the "30."

diameter, the push rods, which are adjustable, terminating in revolving mushrooms. The valve springs are entirely enclosed by a neat removable aluminum cover, thus tending to silence the motor. The camshaft is a drop-forging, the cams being cast integral therewith, and runs on three phosphor-bronze bearings. The crankshaft is a drop-forging and runs in three main bearings which are also made of phosphor bronze. The connecting rods are drop-forged and the pistons are fitted with four rings.

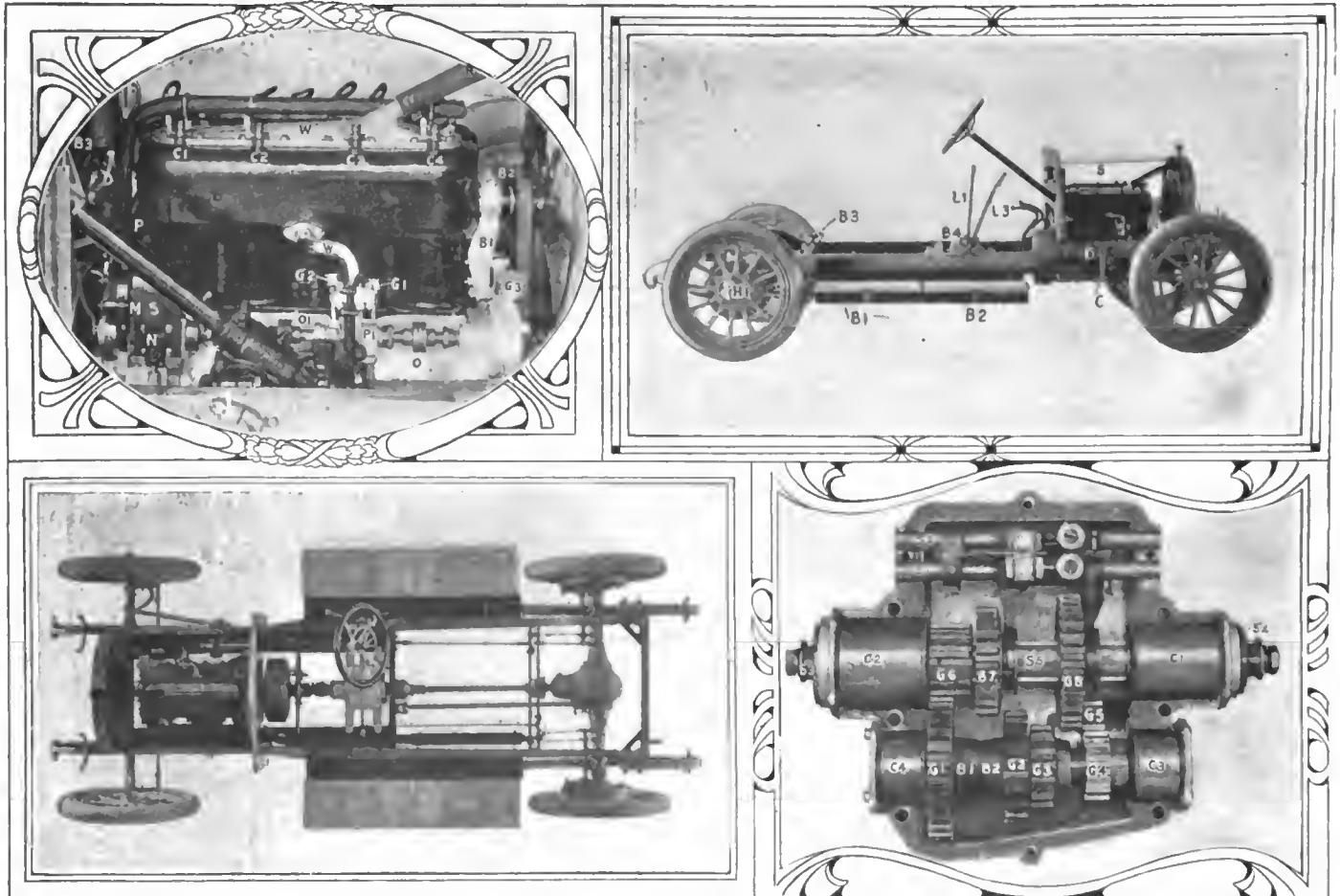

Fig. 1—Right-hand view of the Warren "12-40" motor, showing magneto, waterpump and steering gear

Fig. 2—Plan view of the new Warren "12-40" chassis, showing the general assembly of the units

Fig. 3—Side view of the Warren "12-40" chassis, presenting a clean exterior, showing the neat tool boxes

Fig. 4—Transmission of the Warren "35," with the top half removed, showing the relation of the gears

THE motor of the new Warren "40" is shown in Fig. 1, from which it may be seen that the cylinders are cast en bloc with an L-shaped head. It has four cylinders of 4 1-4 inches bore and 4 3-4 inches stroke. The illustration shows the right-hand side of the motor. The water cover W is of cast aluminum and extends the whole length of the cylinders, delivering the water through a rubber connection to the radiator. Compression cocks C<sub>1</sub>, C<sub>2</sub>, C<sub>3</sub>, C<sub>4</sub> can be seen and these are fitted with priming cups in the event that it becomes necessary at any time to make an injection into the cylinders, as for instance, when starting in cold weather. The valves are located at the left-hand side of the motor and are 2 1-8 inches in

A vertical shaft extending both above and below the motor is driven by suitable gearing from the crankshaft, the upper end operating a timer and the lower end driving the oil pump, which is of the gear type. The oil is taken from the lower half of the base chamber and forced by the pump through a sight feed situated on the dash to the four sumps below the connecting rods, the rotation of which atomizes the oil and forms the splash system. A carburetor of the float-feed type is located on the left-hand side of the motor, being attached to it by means of a bifurcated cast-aluminum intake manifold. The cooling of the motor is effected by means of a cellular-type radiator with 1-4-inch square sections. The water flows from

the radiator to the centrifugal pump *P1* in Fig. 1, which is driven by the shaft *O* off the half-time shaft, delivering the water through a single pipe to the center of the cylinder casting. Greasers *G1* and *G2* are provided on either side of the pump in order to maintain the efficient lubrication and prevent the water leaking through the packing glands, of which there are two. The pumpshaft is extended to the rear and drives the magneto, which is of the Bosch high-tension type. The magneto *M* rests upon a ledge formed by one of the arms of the motor and is attached thereto by means of a steel band *S* and the clamp *N*. In addition to the magneto an independent ignition is provided by means of a high-tension distributor and single-unit coil, which is located on the dash, the distributor being situated on the right-hand side of the motor. Fig. 2 shows the method of suspending the motor upon a sub-frame by means of four arms cast integral with the upper half of the aluminum base chamber. The front end of the crankshaft, which carries the master pinion of the timing gear set, is extended through the

certaining the correct amount of oil that should be in the motor as well as providing a means of emptying all the oil.

The clutch is of the conventional cone type, the male member being of cast aluminum and faced with leather. The springs that maintain the tension have adjustable slips, and the shifting yoke ring fitted with ball thrust is made so that it can be readily removed. Between the clutch mechanism and the transmission there is a short shaft, each end of which carries universal joints all made of steel forgings. Fig. 6 shows the general assembly of the transmission, which is located amidships and suspended by the arms *A1*, *A2*, *A3* and *A4* upon the continuation of the sub-frame which carries the motor. This frame is attached at the forward end to a cross member of the main chassis and at the rear to the centrally located pressed-steel cross member. This is clearly shown in Fig. 8. The housing of the transmission is a one-piece aluminum casting, the gearshafts being situated vertically one over the other. Referring to Fig. 6, it will be seen that the primary shaft *S* provided with

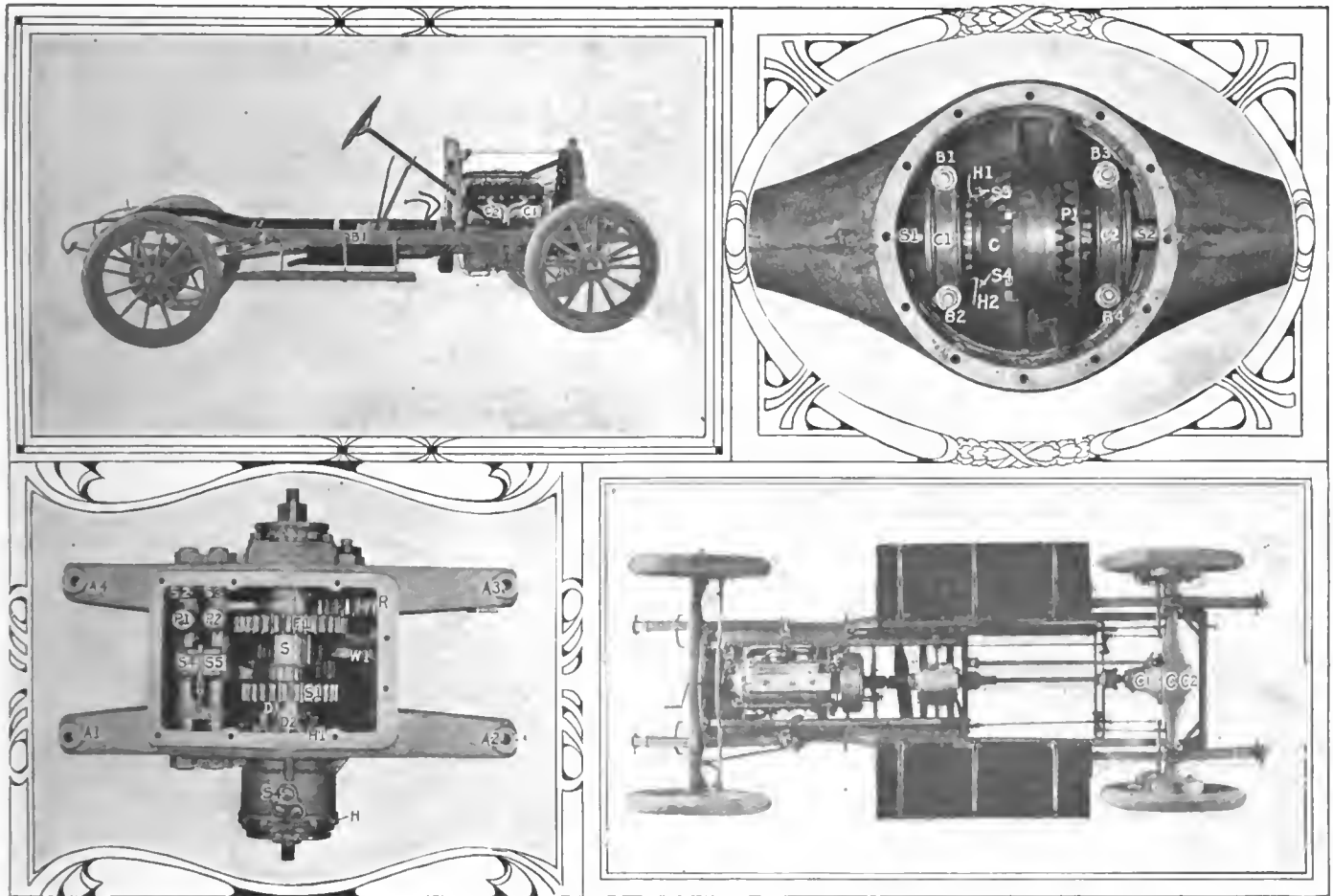

Fig. 5—Side view of the Warren "35" chassis, from which it can be seen that cleanliness has been aimed at

Fig. 6—Plan view of the transmission of the new Warren-Detroit "12-40" chassis, showing the long suspension arms

Fig. 7—Interior view of the rear axle of the 40-horsepower model with the front cover removed

Fig. 8—View of the 40-horsepower chassis from underneath, showing how the running boards are attached to the chassis

front end of the base chamber and a pulley is attached thereto. Fig. 1 shows the bracket *B1*, carrying at its upper extremity the fan and shaft, and in order to prevent the flat fan belt from slipping an eccentric adjustment is provided. By loosening, the nut *B*, which holds the clamp bracket tight, and rotating the enclosed boss an eccentric movement is transmitted to the fan shaft, thereby tightening the belt.

The spark plugs, of which there are eight, are located in the valve caps in the cylinder heads, and the wiring is conducted by means of the fiber tube *L* which is held in position by two clamp brackets fore and aft. Drain and level plugs situated in the lower half of the crankcase afford ready means of as-

integral splines carries the sliding pinions. The pinion *H* is in constant engagement with a secondary shaft and is fitted with dogs *D2*, and when the dogs *D1* are caused to engage with *D2* by sliding the rod *S2* forward the direct drive is obtained. The pinion *S1* when slid rearwards engages with the second speed gear-wheel of the secondary shaft, thus providing the second speed. When the sliding member *S3* moves forward the pinion *F1* is forced to engage with the secondary shaft gear-wheel by means of the lever arm engaging with the collar. The reverse pinion is shown at *R*. Slots *S4* and *S5* accommodate the drop arm, which is in direct communication with the change speed lever, and a slide *I* is interposed between these



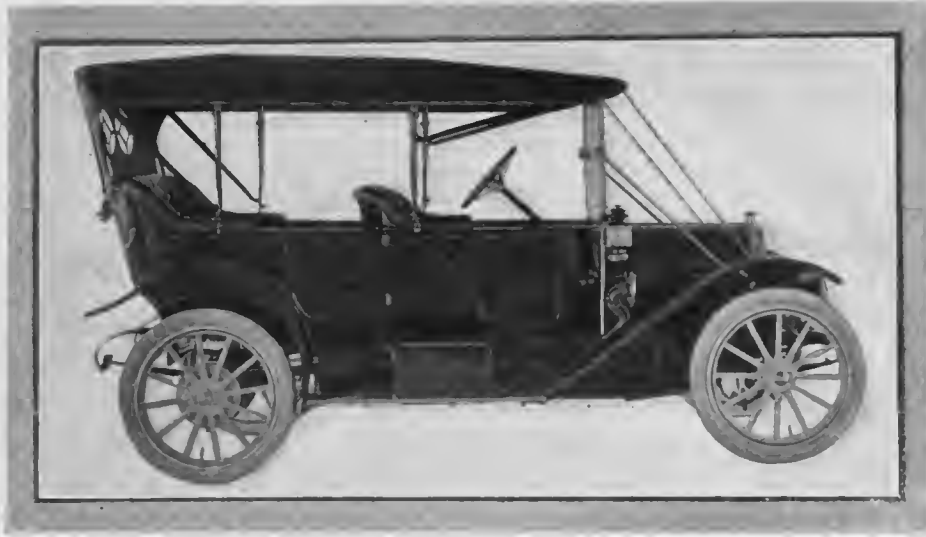

Fig. 9—Warren "12-40" fore-door touring car with flush-sided body

two in order to prevent the engagement of two sets of gears at the same time. To maintain the gears in proper mesh the slides S3 and S2 have V-notches cut in them and corresponding plungers housed in P1 and P2 and spring-urged, engage with the notches and thus hold the gears in position. Ball bearings are used throughout the gearbox for carrying the shafts and are mounted in cages held in position by the retainer S4.

#### Feature of Rear Axle Is Its Accessibility.

A general idea of the rear axle can be obtained from inspecting Figs. 2 and 8. The extension of the gearbox shaft is squared and receives half of the forward universal joint which engages with the propeller shaft, the rear end of the latter terminating in a second universal joint. The housing of the rear axle is a drop-forged steel stamping fitted at the front and rear with removable covers. The forward cover C1 in Fig. 8 carries the driving pinion and shaft as well as the torque tube shown in Fig. 2. The axle proper is of the full-floating type, fitted with ball bearings throughout, and Fig. 7 shows the general arrangement of the interior. The main ball bearings supporting the extensions of the cage C are held in position by the clamps C1 and C2. In order to remove the differential bodily, these clamps may be removed by taking off the nuts B1, B2, B3 and B4 after the jackshafts have been withdrawn. A general view of the chassis is obtained by reference to Fig. 3,

chassis. This eliminates unsightly brake levers outside of the frame and the running boards are formed into compartments 4 inches deep for carrying tools and similar accessories.

Two sets of brakes are provided and operate upon a 14-inch drum attached to the rear wheels, the service brake, operated by a pedal, being of the external contracting type, while the emergency brake expands inside the drums. The wheelbase of the "40" model is 116 inches while the tread is 56 inches as a standard; for Southern trade, however, a choice of 60 inches is given. Artillery wheels with 1 1/2-inch spokes are equipped with demountable rims which carry 34 by 4-inch tires.

Particular attention seems to be paid to the body work fitted to the Warren chassis, eliminating everything that is superfluous, and including in the purchase price, which is \$1,700 for the 40-horsepower model, almost everything that is required for comfort. The general equipment includes headlights, side and tail lamps, mohair top and automatic wind shield with other minor refinements.

Passing to the new "35" model, the general details incorporated in the larger model apply to this type. The motor is cast in a similar manner and has a bore of 4 1/8 inches and a stroke of 4 1/2 inches. The valves in this motor are located on the right-hand side as may be seen in Fig. 5, which shows the valve covers C1 and C2. The difference in the price between this model and the 40-horsepower car is in a measure due to the size of the motor. The rear axle of this model is not of the full-floating type and the brakes are 12 inches in diameter. A general view of the transmission is shown in Fig. 4. It will be seen that this type has the housing divided in two halves with the shafts lying parallel to one another, horizontally to the frame, the shafts being carried on roller bearings. G6 is the master pinion with which G1 engages; G7 in mesh with G2 gives second speed, and the first speed is obtained by meshing G8 and G3. The reverse is obtained by engaging G8 with the intermediary pinion G5 which is in constant mesh with G4. The direct or third speed obtains when the gear G7 is slid along the shaft forward so that G6 enters in the interior of G7. The lay shaft is always running as the gears G6 and G1 are constantly in mesh.

Previous mention has been made of

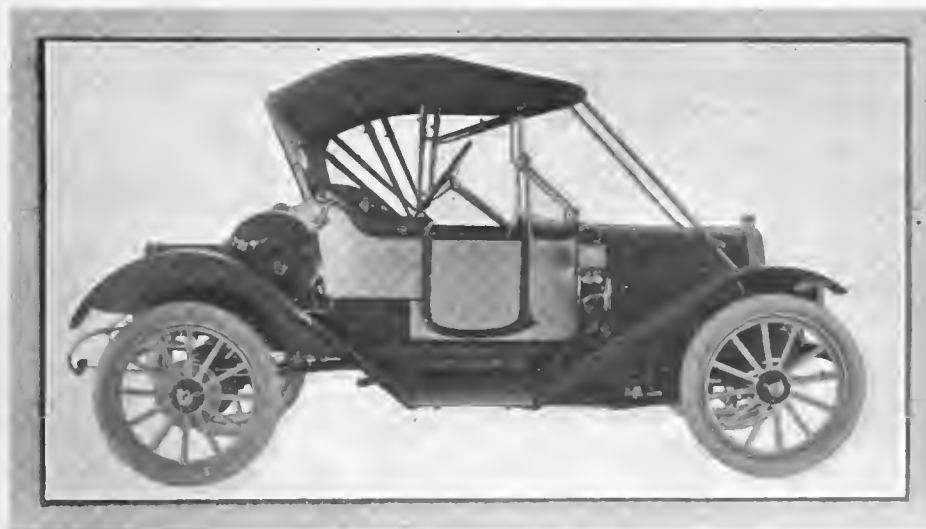

Fig. 10—Fore-door runabout fitted to a "35" Warren chassis, with top, wind shield, gasoline tank and trunk



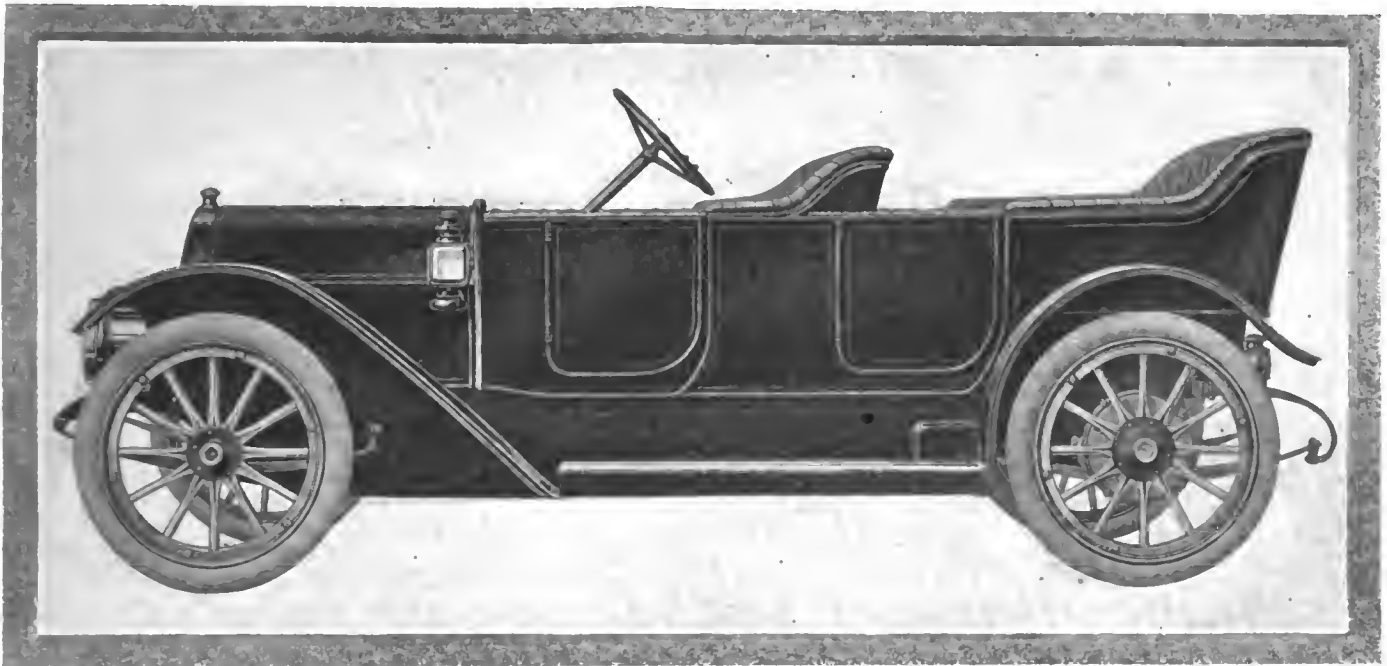

Fig. 11—Standard fore-door touring body fitted to Warren "35" chassis with restrained body line giving a straight-line effect

the Warren "30" in this article, and it only remains to state that the car is in every mechanical essential the same as last year's model. The motor, which has a bore of 4 inches and a stroke of 4 1-2 inches, has remained unchanged and the same applies to the transmission and axles. Additional equipment has been included in the price of this year's car, however.

## Useless to Worry Over Valve Stem Lubrication

*After the engine has been running for a time a film of oil will be found to have collected on the valve stem which amply lubricates the same, and, if a little pulverized graphite has been placed upon them in assembling, no trouble will be experienced.*

IT is quite practicable for valves to work without any attention, so far as their lubrication is concerned, as after the engine has been running for a while a slight film of oil, which has found its way past the cylinder, will have collected upon the stems. If the cylinders are over-lubricated the oil is apt to collect on the stems, gumming them and causing them to stick to their seats.

Where there is any tendency to stick it would be well to allow some kerosene to pass through them. This is a great cure for stickiness on the part of the valves and will be found to relieve them at once. The greatest evil which can occur from an excessive amount of oil reaching the valves is that of carbon deposit. This would, if it held the valve open, cause a loss of compression and hence of power.

## Care on Country Roads a Necessity

*A lack of foresight is a dangerous thing on a country road where a sudden turn may bring the unwary automobilist face to face with a machine speeding in the opposite direction, with a driver who is also unprepared for the contingency. Ditching a machine is at best a dangerous and unsatisfactory entertainment.*

UNDERESTIMATING the other fellow, while as a rule a rather unsafe principle, becomes at times the very essence of safety. In touring about the country there are various con-

tingencies which arise. Whether these contingencies can be classed (after the trip is over) under the heading of incidents or accidents depend upon such a variety of things that it would be impossible to start to analyze them. The largest factor in keeping them under the former head is that of foresight.

There are any number of short "S" turns which are so completely banked off by intervening trees that two cars approaching from opposite directions would hardly have time to veer off to the edge of the very narrow road unless the warning horn was sounded before the turn was negotiated. There are other numerous types of curves and other road conditions which should enforce upon the careful driver's mind the necessity of keeping his attention fixed on the road if he hopes to offset the approaching driver's mistakes.

## Buy Suitable Spark Plugs

*Spark plugs as well as any other kind of plug are made in different lengths. It is possible to buy them either too long or too short, as it has been found by experience that to have either one of these two conditions represents a fault.*

ONE of the great reasons why motorists do not get the best possible results from a very good engine is the fact that the spark plugs may be unsuited for the spark-plug hole by either being too long or too short. If the spark plug is too short the spark is concealed around a bend or behind a wall of metal which interposes itself between the spark aperture and the combustion space. When the plug is too long, the end is apt to glow after a prolonged contact with the hot gases. The spark plug in this case projects so far into the cylinder that it does not get the benefit of the water-jacket space which only can effect the upper part of the plug, leaving the lower extremity subjected to the extreme temperatures of combustion.

The glowing spark-plug points will ignite the gases long before the proper time and will cause them to rapidly burn away or fuse together.

The ideal condition is obtained when the end of the spark plug is just flush with the bottom of the spark-plug aperture in which case the plug is kept cool and the spark occurs in the correct place.

ALTERING VALVE LEAD—The lead of a valve can be altered at any time independently to the cam, by setting the teeth of the timing gears differently.



International road near St. John's, P. Q., before scraping



Road scrapers working on international road near Lacolle



Showing a fine stretch of road near Lacolle after scraping

## Improving the Roads of the Dominion

*The Automobile Club of Canada is devoting much time and money to the improvement and marking of the roads. Efforts are afoot to improve and properly signboard the international road between Montreal and Rouse's Point, N. Y.*

IN considering the subject of roads in Quebec Province, Canada, it may be said that Government intends to expend the sum of \$250,000 during the present year for improvements and the making of new highways. One must not lose sight of the fact that the Automobile Club of Canada is eminently visible in every phase of enterprise in connection with the construction of these highways. As a single instance, it is due to the club's persistent work that the authorities of Quebec Province were induced in the year 1910 to increase the State subsidy for the upkeep of roads from the original 50 per cent. basis to 75 per cent.

The revenue derived from all fees collected and penalties imposed within Quebec Province under the section known as "Application of Revenue," is transmitted to the Department of Agriculture, to be applied to the improvement of Provincial highways. Fees and fines have amounted to the sum of \$50,000 during the fiscal year just ended.

The members of the Automobile Club of Canada have at their own expense already succeeded in establishing permanent guide signs and caution signs in several sections of the Province, and especially along the international road which extends a distance of 51 miles, covering the course between Montreal, Canada, and Rouse's Point, New York. At the present time they are concentrating their efforts to induce the Quebec Provincial Government to build a State road from Quebec city (the route taking in St. John), to Rouse's Point, a stretch of 230 miles. The line cuts through many localities of signal historic interest. During the year 1910 the club brought about the building of 15 miles of first-class roadway along the South shore of Montreal Island.

Registration figures show that there are 4,000 automobiles in commission within the Province of Quebec. Of this number 1,400, or more than one-third of the total, are maintained in Montreal. Quebec Province has a multitude of drawbacks not found in Ontario; for instance, one of the most serious is the absolute refusal on the part of the Provincial authorities to permit automobilists even to pass through the territory in many sections, while no owner residing within the forbidden lands may own a motor car with the view to driving it there. One of the most hostile sections is Prince Edward Island.

At the same time, it must be admitted that the motorists residing within Quebec Province are doing all in their power to induce the authorities to pursue modern methods of road build-

ing and put the Provincial highways in proper shape to accommodate automobile traffic.

Montreal is the center of activity in the matter of automobiles, so far as their propagation as vehicles of travel is concerned. There is no company in Quebec Province which is devoted to the manufacture of motor cars, not even of bodies or parts. The man who sets his mind upon possessing an automobile, buys one that is made either in England, France or the United States—with now and then an exception in the way of an Italian-made machine. But the large majority of the 4,000 motor cars in use in Quebec Province were made in the United States. There is a duty of 35 per cent. on automobiles imported into the Dominion.

If the owner of an American-made motor car were asked why he chose that particular type of machine he would invariably answer: "Because of our closeness to the United States, and the readiness with which we can get parts, in case of an emergency. It means only four-and-twenty hours delay at the utmost; while if we were to order parts by cable from England, France or Italy it would necessitate a delay of at least a fortnight, if not longer."

There is no chauffeurs' club within the Province. The average wage paid to the driver is \$15 per week. Every person other than a chauffeur who drives a motor car pays a license of \$5 per year to operate his machine. Besides he is required to pay an additional registration fee annually, based on the following graduation: Motor cars up to 25 horsepower are each taxed \$5; from 25 to 35 horsepower, \$10; from 35 to 50 horsepower, \$15, and \$20 for every automobile above 50 horsepower.

Quebec Province maintains reciprocal touring relations with such States within the Federal Government as permit Canadians to cross their borders bearing a Dominion license.

The laws governing the operation of motor cars in Quebec Province are quite strict. A fine of \$10 is imposed, or sentence to imprisonment for not less than six months is inflicted (within discretion of the magistrate) upon "the person who interferes or tampers" with a vehicle without the permission of the owner thereof.

The law regulates the speed limit to nine miles per hour in towns and cities and to fifteen miles per hour in the open country.

The streets of Montreal, which city is the center of automobile activity in the Province, are so narrow that they constitute a continuous source of annoyance to drivers of every sort of vehicle, motor cars in particular. Fifty per cent. of the paving material used in Montreal is asphalt. The putting down of wooden blocks has been discontinued entirely. The cost of laying asphalt, including a 6-inch concrete base and a "cushion coat" of asphalt, for the fiscal year just ended was \$2.11 per square yard. There are two municipal asphalt plants, devoted chiefly to repair work.

## France to Change Its Rule of the Road

*In July of next year the direction of traffic on the highways of France will undergo a transformation, the present keep-to-the-right rule being superseded by a law similar to that which now obtains in the British Empire, where all traffic keeps to the left side of the road.*

FRANCE has flopped over from the right side of the road to the left side, and at the beginning of July, 1912, "the rule of the road" in France will be reversed, and traffic, instead of keeping to the right, as in the past and at present, will be compelled by the law to drive on the left-hand side of the road after the manner of the custom which obtains in Great Britain—even including Ireland. There was a long series of meetings and sittings of the Commission empowered to take the matter under advisement. It is not for the purpose of imitating the British

system that this change has been brought about. The movement is due to two causes: First, the enormous increase in the volume of motor car traffic; and, second, the influence which British-made automobiles have had on the designs of machines manufactured in France.

It was sometimes the practice in the early days of the Continental models for designers to have the steering apparatus on the left, thus compelling the driver to sit on the off-side, this having been the best position for managing his machine in the midst of traffic. While this was a point of vantage in Continental Europe, where traffic was directed to the right, the reverse was the fact in Great Britain. And as the English-made cars increased in number, France woke up to the fact that it behooved her to fall into line. Consequently, the French set out to build their automobiles for use in Europe on the British model, so far as the steering wheel is concerned, and having gone in for motor cars after this pattern, they have found it absolutely necessary to alter the rule of the road.

## Some Problems of Live Rear Axles

### How Selling Points Interfere with Success

*It is suggested here that the salesman, who no doubt has his foot upon the cash-box, too often dominates the construction situation, demanding talking points at the expense of quality of the product, and in making his demand the salesman also makes it impossible for the manufacturing department to properly comply with the same because he fixes the price too low to pay for the work that he wants.*

MANUFACTURING automobiles, speaking broadly, is attended by many serious difficulties that do not obtain in the other arts from the manufacturing point of view, and in looking into these problems it takes but a little investigation to disclose the inharmonious relations that are at the seat of the most formidable of these troubles. The sales end of the automobile business dominates the situation to a far greater extent than might be generally understood, and the engineers, as well as the constructors in the shops, are too often engaged in the business of giving to salesmen the greatest number of "talking points" that can be brought under one "canvas," not at a price which is made up by determining the cost and adding a profit, but at a price that the salesman fixes at the time he makes his demand.

There is no possible chance of realizing a good automobile out of a salesman's demand, although he, in his diplomatic way, calls his every demand a mere recommendation. A good salesman is rarely ever capable of appreciating the purely mechanical necessities; his scientific training is confined absolutely to the science of wringing money out of the pocket of a "prospective," and his honesty of purpose, however good it may be, is without value from any other angle of view than his own.

Fortunately, the maker of the better type of automobile employs engineers and other "talent," which, under proper direction, produce the type of car that constitutes a selling point in a broad sense, leaving it to the salesman to enlarge upon the details.

Unfortunately, and let it be said, for the maker as well as for the prospective, the car that is composed of a miscellaneous assortment of selling points aggregated at the instance of the sales department is so lacking in harmony of the relations of these selling points that it would be unnecessary to annoy the engineer of the company, which is all that could happen were he

to be employed for the purpose of producing this product.

Of course, it is claimed for every plant that it has an engineering department, but too often some high official usurps this function, and it goes without saying that a man who is trying to keep the ends of his investment from getting away is the very type of man who is likely to fall into the trap that the salesman sets and this type of engineer agrees to, he not knowing, of course, that a real engineer would put his taboo upon any such activity, and that the poor devils who are told to make an automobile out of selling points are merely working for so much a week, knowing perfectly well that the automobile so made will be a thorn in the side of the purchaser, and a stumbling block for the company that builds it to stub its company toe upon.



Fig. 1—Showing how the jackshaft may be tinned to increase its diameter so as to prevent leakage of lubricant

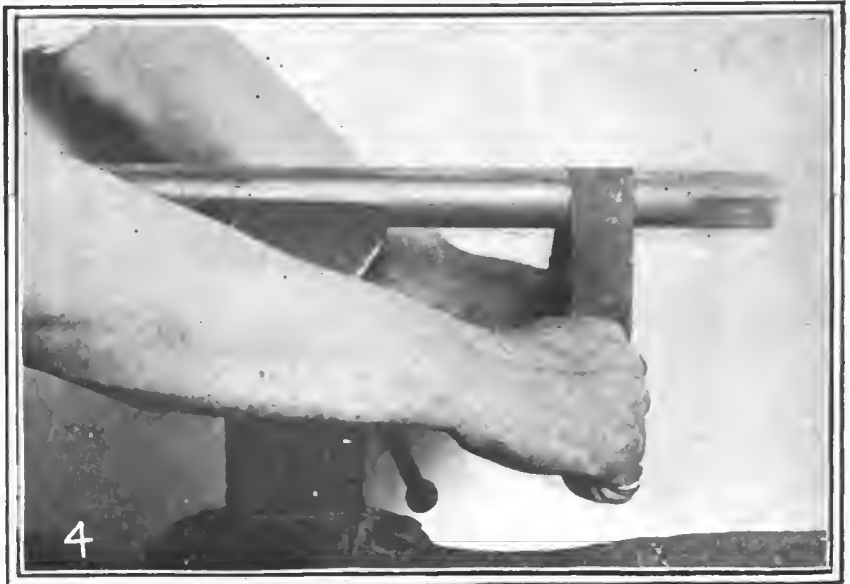

Fig. 2—Showing a worn brakeshoe after having been repaired by the oxy-acetylene process

Fig. 3—Depicting the worn shoe before being fixed up

Fig. 4—Cleaning a shaft with emery cloth preparatory to tinning, also useful for cleaning up a burr

There is no part of the car's mechanism that offers more fruitful thought for the competent designer than the live rear axle and its component parts. The full-floating type of axle with a pressed-steel housing, if properly made, is comparatively light when compared with a webbed casting and the independent assembly of the jackshafts permits of more careful adjustment of the differential proper. The live rear axle is as much in need of lubrication as the motor, yet it is surprising how this one item alone has been neglected or perhaps side-stepped.

A conversation that recently took place in an automobile factory reveals the state of affairs in a nutshell. After a five-hour road test the car was rolled to the running shed and the tester's sheet showed that it was ready for delivery to the customer in perfect working order, and when questioned by the chief engineer the tester stated that it was the best car that had been turned out so far. That may have been the case, but after the test the rear wheels and tires were bespattered with nearly as much oil as it would require to fill the rear axle casing. When the tester was asked if he thought that it was proper to pass a car in that condition his reply was: "Why, they're all like that, and you can't stop it."

It is true that the tester could not be blamed for the construction of the axle, but, nevertheless, it was his duty to report that each and every car that he tested had this defect. Unless the engineering force is apprised of such shortcomings, they are not

in a position to rectify the mistake in the current series, and it is quite possible that mistakes are perpetuated.

Mention has previously been made of building cars at a price fixed by the selling department, leaving the designer no other choice than to evolve a car that will not cost more than a given amount. This method will eliminate refinements and will cause the purchasing department to be guided more by economy than intrinsic value. Manufacturers who do not manufacture the entire car themselves have a good deal to contend with, as they cannot be personally responsible for the goods that are turned out by parts makers. There is just as much necessity for the maker to have a representative, either traveling or resident, who looks after his interests at the parts factories, to assist in the calibration and see that it is properly carried out, as there is to maintain such a department in the factory proper.

Initial price cutting recoils on the maker's head, as will be conceded by any right-minded person, since it will be necessary for the purchaser to remedy the shortcomings by replacing such new parts as show early wear and resorting to artifices in the endeavor to overcome constructional blunders. Matters being in this state, it is proposed to show by the use of illustrations how

some of the inherent defects of live rear axles may be overcome.

The oil-leaking propensities of some rear axles may be remedied by tinning or brazing the shaft, thereby reducing the aperture through which the oil finds its way. This may be seen by reference to Fig. 1, in which a jackshaft is shown in a vise, and the operator in the action of tinning the shaft. It is preferable to put the shaft in a lathe after the tinning operation has been completed, but in cases where it is unhandy emery cloth in the manner shown in Fig. 4 will answer nearly as well. The operation shows the shaft being cleaned up prior to the tinning.

It is most essential that a car should be fitted with a good set of brakes, with adjustments that can be speedily effected. Brake-shoes of the type shown in Fig. 3, the surface of which was originally flat, but which has worn owing to the softness of the metal, are a cheap form and are a constant source of annoyance to the user. With the advent of the oxy-acetylene welding process it is no longer necessary to purchase a whole new shoe, as it can be seen from the Fig. 2 that the surface that contacts with the operating tongue is virtually as good as it was when turned out by the makers.

One has to be somewhat of a mechanic to improve what someone else has left undone. After the time that the unfortunate owner has changed this and altered that, he might have just as well paid a little more money in the first place, thereby saving himself a good deal of annoyance.

# How to Study the Carbureter

## Discussing the Details of Operation

*It cannot be expected that a carbureter will work well every day all the year round under precisely the same adjustments when the atmospheric conditions vary in such wide degree. Every driver will have noticed how a car pulls better on some days than on others and how, when the car is new, the motor responds at once to a touch of the throttle, whereas when the motor has limbered up there is something still to be desired. In discussing these points the Rayfield is used as an illustration.*

can be carried out in a very short space of time by removing the cover C4 which is held in place by three screws. The lower part of the float chamber is fitted with a plug which is removable if it is found necessary to drain the float chamber from time to time from any impurities, such as water, that may find their way inside. The lower end of the spindle S is formed in the shape of a ball which engages with a hole in the lever arm L, which is caused to rock on the pin P1 so that when the gasoline enters and fills the float chamber the needle valve V1 will drop and cover the orifice S2 through which the gasoline enters the carbureter in the first place. The lever and its support are carried on a bracket B3 held in place in the base of the float chamber by a screw D. To make the float chamber gasoline-tight there is a washer W2 interposed between the base and the cap C2.

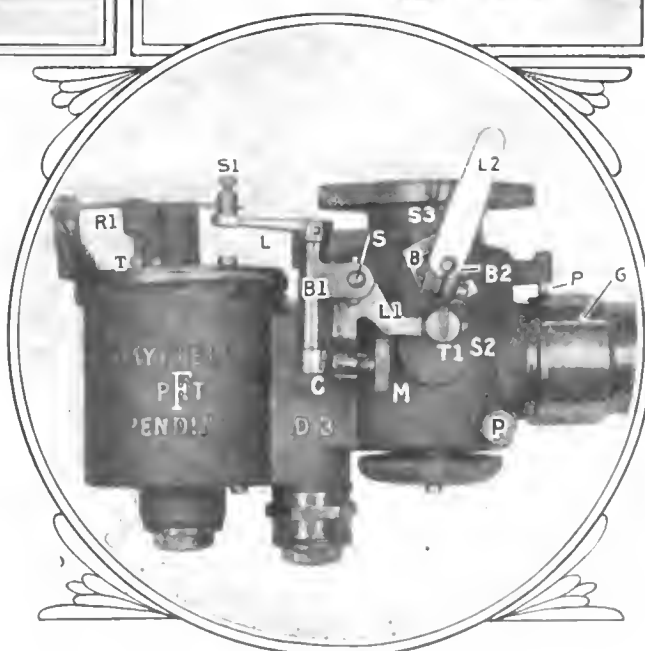
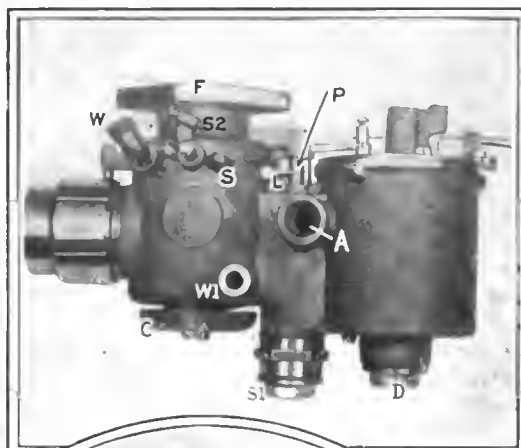
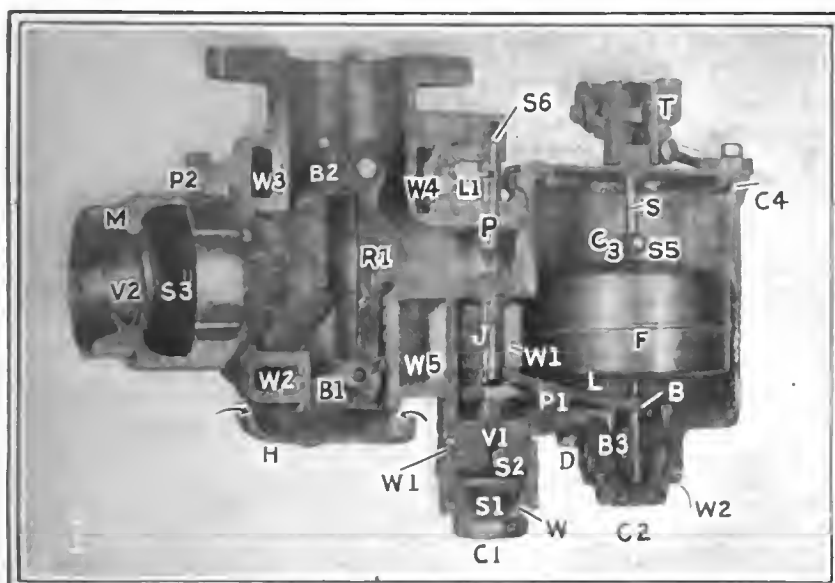

**T**HE vagaries in the performance of the average carbureter are due to the fact that the adjustment of the gasoline to the air is better on some days than on others. This may not altogether be clear at first view, but when one considers the heat of a Summer's day and the intense cold of the Winter or the humidity that prevails on some days as compared to the crispness of others it must be apparent that gasoline will not always combine with the air in the same manner, and its differing volatility under various conditions will be understood.

In order to cope with the difficulties put before the motorist in his endeavor to obtain the maximum results under any condition, be they along the line of efficiency of the motor or minimum gasoline consumption, the Rayfield carbureter offers an example worthy of notice. The general principle of the carbureter follows along the broad lines of carbureter manufacture. Refinements have been introduced whereby through the turning of a milled screw or the pressing of a knob on the dash an alteration of the ratio of gasoline to air can be obtained.

It is proposed to show from the photograph of a carbureter that has been cut in two, as seen in Fig. 1, the relation of the various parts of the mechanism, and later on the two exterior views how these are operated and controlled. On the right-hand side of the illustration is the float chamber containing the float F, which is attached to a spindle S by means of a split clamp C3 and locked in position by means of a screw S5. If it is found necessary at any time to alter the gasoline level such an operation

Fig. 1—View of a Rayfield carbureter cut in half to show the co-relation of the various component parts

Fig. 2—Exterior view showing air intakes and general aspect

Fig. 3—Regulating device by which the flow of gasoline is varied



Below the seating S2 into which the needle valve fits there is a cap attached in a similar manner as C2 with a washer that contains a fine mesh wire gauze S1 and the connection for the gasoline feed screws into the base of C1. The needle valve seating is also removable, as the whole part S2 can be unscrewed from the main body. It will have been noticed that there are no weights in the float chamber, but this is carried in one piece with the needle valve V1, as seen at W1. The tip of the valve is made of steel and less susceptible to wear than brass or phosphor bronze. The weight is hollow and crossed drilled to allow the gasoline to pass from the float chamber to the spray nozzle or jet J. The jet is screwed into the part of the casting forming part of the mixing chamber and can be removed after the seating S2 has been removed, as it has a slot in the base for a screw-driver to get a purchase.

The quantity of the gasoline that is allowed to pass through the jet is controlled by an inverted plunger P with a conical end and the height of which is regulated by the small lever L1. One of the features of the Rayfield carbureter lies in the method of controlling this plunger. A spring S6 is placed in the recess above in order to insure that the plunger will return after being lifted by the lever. Without dealing at the moment with the operation of the plunger it might be mentioned that the higher the plunger is lifted the more gasoline will be allowed to pass into the mixing chamber.

Opposite the orifice of the jet there is provided a constant air intake, but it is not shown in the illustration; it can be seen, however, at A in Fig. 2. The mixing chamber is water-jacketed, the conduits through which the water passes being shown at W2, W3, W4 and W5. The base of the mixing chamber is open, being covered partially, however, by the cap H, air passing in as indicated by the arrows. Two butterfly valves situated in the mixing chamber control the main body of mixture at B2 that passes to the intake manifold, and the smaller butterfly B1 controlling the supplementary air which is required as the gasoline is increased by the automatic lifting of the plunger regulated by the throttle lever. On the left-hand side of the mixing chamber there is an automatic air valve that works in accordance with the suction of the motor. The valve is shown at V2 with a section of the metal cut away to show the nature of the valve and the spring S3 that holds it on its seat at slow speeds. A spring plunger P2 is situated above the valve and registers in slots cut in the outer casing M. The adjustment of the valve is controlled by screwing the casing M one way or the other, which has the effect of bringing the seat on which the valve rests nearer or farther away from the main body of the carbureter, thereby increasing or decreasing the tension of the tension spring.

Having thus dealt with the internal organs, it remains to show how the adjustments are effected and how the relation of gasoline to air is altered to suit certain conditions.

Just what effect the extra air valve has over the carburetion can be summed up in a few words. In order to equalize the flow of gasoline and air it must be remembered that as the suction of the motor increases with a corresponding increase of speed the capillary attraction on the jet is increased and more gasoline is caused to spray through the orifice of the jet. The air, however, does not increase in the same proportion, therefore the automatic air valve is employed so that with the increase of suction the spring will be overcome and allow additional air to pass in and mingle with the gasoline.

It has already been shown how the plunger P in Fig. 1 is formed and how if this is raised or lowered the quantity of gasoline that will pass through the orifice will be increased or decreased respectively.

Fig. 2 shows the lever L and the part of the plunger that is exterior of the carbureter. The lever L is caused to move up and down carrying the plunger with it. The constant air intake is shown at A and the water connections for heating the mixing chamber to assist evaporation and prevent condensation are shown at W and W1.

The adjustments are shown in Fig. 3. The small shaft S is connected to the lever L in Fig. 2 and therefore to cause the plunger to rise or drop is a matter of causing the shaft S to rotate. The tube C extends to the dash and terminates in a bracket with a push knob. This knob is attached to the extension of the wire R1, which in turn is attached to the lever L by the set screw S1. If the knob on the dash is pushed in or pulled out the lever arm will be moved to and fro, and being as it is connected by a shaft inside the bracket B1 to the cam C, and rotation will cause the cam to ride on the set screw M and so turn the shaft S which will move the plunger over the jet.

This offers a means of increasing the amount of gasoline for starting purposes and fixes the slow-speed setting. The limit of travel in this direction is regulated by the set screw S2 in Fig. 2. The lever L1 in Fig. 3 carries at one end a slot with a tongue held in place by the screw S2. The tongue T1 is in contact with the curved block B and as the throttle lever L2 is moved the tongue will ride on the block B and cause the lever L1 to move and so turn the shaft S, thereby raising the plunger. The butterfly valve shaft is attached to the block B2 and the adjustment of the lever L1 in relation to the throttle is regulated by the screw S3, which causes the block B to press down on the tongue or recede from it. The plug is connected with the water circuit and should be unscrewed to let the water out of the jacket whenever it is found desirable to let the water out of the motor and radiator in the case of frost, otherwise the water may expand and burst the carbureter casting.

## When Judgment Whispers Don't

- Don't imagine that taking care of an automobile is a matter less serious than the work of nursing a child; trouble will come if either is neglected.
- Don't believe that the noise of a motor is of lesser significance to the well-being of the car than the whine of the baby is an indication of an ill-balanced digestion.
- Don't overlook the fact that oil is great stuff in putting deranged organisms and mechanisms into order; a good dose of lubricating oil will benefit the car much as castor oil will silence the suffering baby.
- Don't misunderstand the desire of the motor for gasoline; it delivers its useful work in just the proportion as it drinks up the stuff.
- Don't entertain the idea that a good ignition system is less important than a sufficient supply of gas; the stimulant must be burned to make the car move.
- Don't monkey with the ignition system of your car; it ought to be below your dignity to play with the sundries.
- Don't be impressed with the self-conscious air of the chauffeur adjusting the carbureter; he may be unable to restore the good adjustment which he spoils.
- Don't underestimate the value of the man who goes about his work on the automobile without trying to show off and to put up a bluff.
- Don't tell your friends about the virtues of your chauffeur and then object when the fellow demands a raise; someone might have handed him the tip.
- Don't frown when you pay for the maintenance of your automobile; an automobile, if rightly applied, more than pays for the cost of buying and keeping it.
- Don't think that the only way in which an automobile pays is in cash coin; pure atmospheric air, moving at a speed of 20 miles or so, is more useful than gold and, therefore, it has to be paid for.
- Don't forget that the refreshment brought about by a 20-mile ride enjoyed every evening will stretch your lifetime to three-score and ten years.
- Don't pour gasoline through a dirty funnel. If it has been standing for a while, clean it out.

# Peeps Thro' Goggles at Distant Lands

## What the Foreigners Are Doing in Automobiling

*Siam's King's official physician is provided with an automobile—British discussing visible sign-posts—London's Fire Brigade being rapidly motorized—Building cars to measure—Imports of gasoline into the United Kingdom—Coronation Durbar in Delhi brings demand for automobiles.*

**F**AR-OFF, benighted Siam is stepping out into the spotlight, so far as the adoption of automobiles for public service is concerned. The latest example of modern enterprise along these lines is the purchase of a 10-horsepower motor car for use by the Medical Officer of the Bangkok, Siam, Board of Health, Dr. Hightet, who is also physician to the King of Siam. He will employ the automobile extensively about the country, since his professional duties are calling for a wide circle of work.

In dealing with the scheme for providing a unification of the erection and maintenance of warning signs in England for the benefit of automobilists, the British Roads Improvement Association has considered the question of the visibility of the posts carrying the signs at night. The scheme involves a series of five sign posts, each differing in color, and so painted as to be seen after nightfall.

London's automobile Fire Brigade has met the expectations of even the most sanguine promoters of the new plan. The force of this statement will appear when it is said that London has decided to discard horse-drawn fire engines and horse carts altogether. The Finance Committee of the London County Council having the preparatory matters in hand, estimate the cost of the complete conversion of the Fire Brigade equipment—more than 210 appliances—at \$1,050,000. The Treasury will be asked to sanction a period of ten years for the repayment of so much of the expenditure as would be considered equal to the net addition to the capital value of the Fire Brigade's plant.

Certain English automobilists are arguing with the aim to bring about car-building to accommodate individual requirements, after the manner that one would order his tailor to make him a suit of clothes. Special attention is called to the individual requirements in the distance between the seat and the steering-wheel. One motorist who confesses to be "of generous proportions" bewails the fact that not he alone, but many other "motorists of huge anatomical proportions" frequently are forced to subject themselves to painful contortions in order to get safely ensconced behind the wheel; while small men are seen steering with the wheel in an awkward position, much too high for them. The complainants seek to have all of these errors of construction changed.

The United Kingdom imported 30,000,000 gallons of gasoline during the first six months of the present year, ending the 30th of June. Of this amount, the bulk came from the North American oil fields. Only 10,000,000 gallons was sent from the Far East, the quantity falling below the supply shipped from that section of the world into England during 1909 and 1910—years in which the American supply to England was very low. There were 3,000,000 gallons of Far East imports into Holland, which amount was reshipped to England, during the first six months of this year. This product came from the Shell Royal Dutch fields. Russia gained considerably over previous years, her supply of Grosny gasoline into England amounting to 5,000,000 gallons.

The Far East is raising a loud voice in the call for the automobile. The Indian Government is manifesting a spirited interest in this respect, having just ordered thirty English-made, 15-horsepower, four-cylinder motor cars for official use during the forthcoming Coronation Durbar to be held in Delhi on the occasion of the visit of their Majesties, King George V and Queen Mary.

## Soft Water for Radiators

*The thoughtful garage owner and motorist can have the very best water for the radiator by the installation of a device for catching the rain water from the roof of the garage and keeping it bottled up so that it is handy at any time. The water can be used not only for the radiator, but also in washing the finely finished parts of the body.*

**T**HE virtues of soft water for the automobile radiator are well known and recognized by all those who have any knowledge whatever of the preservation of metallic surfaces which are in contact with water. Ordinary city hydrant water always contains a number of impurities which are extremely injurious to metal even if they are present in very small quantities, the greatest amount of damage, perhaps, being caused by the carbonic acid which is present to a greater or less extent in our city water. This acid is very active when heated.

The hardness of water is determined by the amount of lime or magnesia it contains which have the ability to decompose soap. This faculty provides a means of measuring the hardness of the water and by chemical relations involved determines the purity. Rain water lacks to a great degree the corroding elements and hence is valuable for use in automobile radiators. The accompanying wax illustration shows a method whereby the rain water may be caught from the roof of the garage, filtered and kept for use at any time.

If the tank is made large enough the water may be used in washing the more finely finished parts of the body, thereby preserving the delicate finish for a much longer time than if the ordinary hydrant water were used. The water flows from the

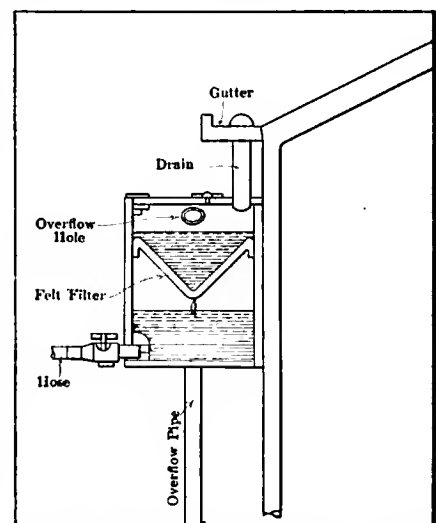

Showing method of installing rain-water tank so as to take the water from the garage roof.

# The Heat Losses of Cooling

## Enforced Radiation a Necessary Evil in Any Engine

*Greatest among the sources of loss of thermal efficiency stands the cooling process, which, although necessary, can, by an intelligent manipulation born of a knowledge of the basic principles involved, be made to perform its work in the most economical manner possible.*

**A** LONG with all the other ideas of obtaining "something for nothing" in a mechanical way that of producing an engine without some process of cooling, with its consequent loss of thermal potency, has long passed away. The flow of heat through a body, such, for instance, as the walls of the cylinder of a motor, is a function of the time of the process, the area of the surface involved, the difference in temperature of the opposite surfaces of the body, the conductivity and the thickness. The thickness, in so far as the purpose of this article is concerned, may be neglected. A knowledge of these facts is of use if taken with the other phenomena of the gas engine cycle and used to secure the utmost efficiency from the engine without sacrificing certain necessary features in construction.

Since the longer the cooling process is carried on for each charge brought into the cylinder, the more heat (which has been abstracted from that charge) will be thrown away by the radiator, it is evident that the best conditions obtain when the exploding charge is submitted to the cooling influence of the cylinder walls for the shortest length of time. This means that more charges must be burned per minute in order to have each charge acted upon for a less amount of time and also, since, as we have stated, the radiation is a function of the time, to allow a less amount of heat to pass through the walls. Evidently the more explosions per minute the higher the piston speed, which in-

dicates that the greater the number of revolutions per minute at which the motor is run the lesser the amount of heat lost through the cooling medium from a per-horsepower standpoint.

The area of the metal exposed to the burning charge is directly dependent upon the bore and stroke, with the exception of the irregularities in the shape of the combustion space due to ignition system openings and valves. Hence the factor of area is determined very closely in the primary design of the motor. It serves to illustrate, however, that there is a greater loss, per horsepower, of thermal efficiency due to cooling in a large engine cylinder than in the smaller high-speed type. Combining the two functions of exposure, time and area, it will be seen that the least amount of heat lost is under the condition of having the least area exposed per unit of time per explosion. This again brings in the condition of high speeds for the reduction of the loss of thermal efficiency due to cooling.

In order to cut down the heat extracted by the cooling fluid from the burning gases the difference in temperature between the inner and outer faces of the cylinder walls must be as small as possible. Since the heat of combustion is fixed and definite, the nearness of the temperature of the cooling water side of the cylinder wall to that of the combustion side will be determined by the heat of the cooling water, the hotter this is the less the difference in temperature between the two faces. The cooling water must therefore be allowed to run as hot as practical limits will permit. The heat of the cooling water is regulated by either the amount of water passing through the jackets in a given time or by the rapidity of the circulation. Good practice on level ground is to have the cooling water at about 180 degrees Fahrenheit; this leaves a margin before reaching the boiling point of 32 degrees, so that in climbing a long steep hill where the motor will heat up owing to the open throttle and late spark there will not be such a tendency to overheat the water.

The remaining factor of conductivity is negligible in this discussion, as it is constant for all the standard radiators in use and may be regarded as a fixed quantity.

The set of curves given in Fig. 1 will illustrate graphically the amount of heat lost in cooling in the average motor of good design running under mean conditions. The four curves show the thermal equivalent of the brake horsepower, the average heat lost per hour through the medium of the cooling water, the sum of the heat lost in cooling and used in producing the brake horsepower and the total heat supplied to the engine with the fuel. Since the third-mentioned curve is the sum of the heat lost in the water and that used in brake or useful horsepower, the distance between this and the top curve of heat supplied with the fuel will represent the heat losses by other means than by the cooling water, that is through the exhaust and by friction. An examination of this set of curves will show that the heat lost to the cooling water is more than double that used in producing useful work at the lower number of revolutions, while the ratio grows less as the revolutions become higher and the cooling water is exposed to the heat of each explosion for a less amount of time.

Although the cooling fluid carries off much of the heat in the cylinder walls it must not be supposed that the walls are ever of the same temperature as the cooling fluid even at the coolest part of the cycle, for the remaining dead gases after the exhaust are of very high temperature. On the suction stroke this temperature is reduced by the incoming mixture, but even then the walls are hot enough to contribute toward heating the new charge. It

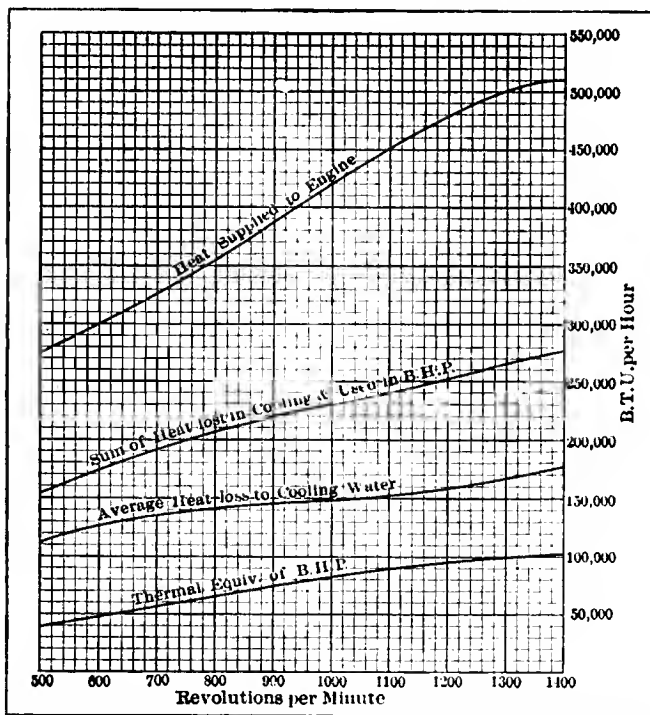

Fig. 1—Showing the amount of heat lost in the cooling fluid as compared with that given up in useful work. (B. H. P.) The distance between the two upper curves gives the heat lost through other causes

would be impossible for the walls to give up all the heat absorbed by them during each explosion stroke in so short a time as that which marks the interval between these operations. After the engine has been running a while at a regular speed a rhythmic wave motion of heat rises and falls in the cylinder and cylinder walls. The difference in temperature between the cooling water and the metal of the cylinder walls must, even in the most favorable conditions, be 55 degrees and in very large cylinders even more. Referring to the curves in Fig. 2, the rapidity of rise of the curve of B. t. u. in cooling water referred to piston displacement will be noticed. This is mainly due to the greater temperature difference between the water and the cylinder walls.

The shape of the combustion and expansion space has a very large influence on the number of heat units lost in cooling. The expansion space is of necessity cylindrical, while the ideal combustion space is a smooth and unbroken hemisphere. Omitting the question of structural strength entirely and looking at the matter solely from a cooling standpoint, it is seen that the reduction of exposed area per cubic inch of combustion space is as great as possible in the dome shape of head and since the amount of cooling is a function of the area exposed the advantages of this type of head for the combustion space is evident. Since it is impossible to get away from the cylindrical form of expansion chamber; cylinders are designed so that the engine will be suitable for the work required of it and yet give the least area relatively to the volume of the combustion space. We can find the relation of stroke to bore which will give the condition when the relative exposed area is least by solving the equation of the volume for a minimum in terms of the surface. Let L equal the length of stroke, D the diameter of the cylinder, V the necessary designed volume, S the exposed surface.

$$V = \frac{\pi D^2 L}{4} \tag{1}$$

$$S = \pi D L + \frac{2 \pi D^2}{4} = \frac{4V}{D} + \frac{\pi D^2}{2} \tag{2}$$

Let

$$\frac{dS}{dD} = 0 \quad \frac{dS}{dD} = \frac{4V}{D^2} + \pi D = 0, \quad \pi D = \frac{4V}{D^2}$$

therefore  $D = \sqrt[3]{\frac{4V}{\pi}}$  (3)  
 But

$$L = \frac{4V}{\pi D^2} \text{ from (1) and } D = \sqrt[3]{\frac{4V}{\pi}} \text{ substituting } D = L. \tag{4}$$

That is, the surface of a cylinder of given volume is least when the diameter equals the length. Other practical factors entering in, however, make it better to have a different relation of bore to stroke than that just deduced.

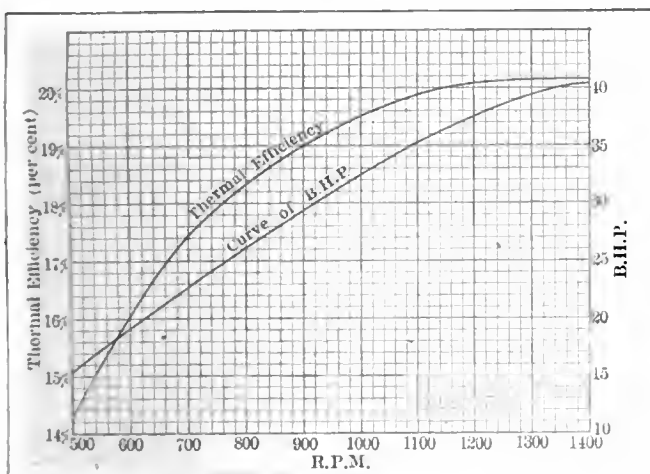

Fig. 3—Curves of B.h.p. and thermal efficiency plotted on the basis of revolutions per minute

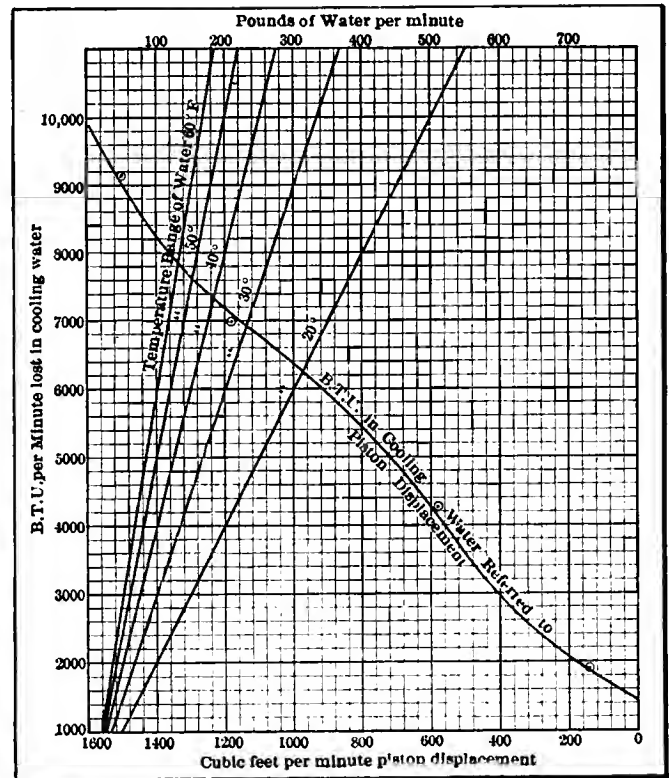

Fig. 2—Curves of B.t.u. in cooling water and temperature ranges. These curves are read vertically from the base up to the curve of B.t.u. in the cooling water, then horizontally to the temperature range curves

The thermal efficiency is affected by many conditions after the engine has reached 1,200 or 1,300 revolutions per minute and, as will be seen in Fig. 3, the slope of the curve, which measures its rate of increase, will fall off appreciably. The curve of brake horsepower will also start to fall off as the revolutions per minute become excessive and the difficulties of overcoming the inertia of gases and reciprocating parts of the engine increase. Fig. 3 was taken from tests on a 36-horsepower motor and is fairly representative of an engine of that rating. The engine was six-cylinder, four-cycle, having a bore of 3 15-16 inches and a stroke of 4 3-4 inches. The rating is according to the A. L. A. M. formula.

### Loss of Power in Motor

Where fiber gears are used to drive the camshaft an evasive squeak will often be heard which can be traced at times to the fiber gears which have swelled so that they no longer fit their driving pinions. The remedy is not hard to apply and will be found to be a success.

SOMETIMES the motor will not be developing its usual power and an unusual scraping sound will be heard. This trouble often occurs with engines having fiber gears to drive the camshafts, which have been in service for some length of time. The cause is the swelling of the gear wheels due to the absorption of the oil, the gears expanding and meshing too tightly with the steel driving pinions, or, at the same time, swelling laterally and rubbing against the casing. This will heat the camshaft bearings.

The remedy lies in replacing the fiber gears or in recutting the teeth of the gears and reducing the pinion to normal thickness by planning or turning in an engine lathe.

A HABIT that can be readily acquired by a new driver is that of throwing out the clutch when turning a sharp curve at any speed. Severe torsional strains are averted and tires saved by this precaution.

### Increases the Power of His Engine Thirty Per Cent.

Editor THE AUTOMOBILE:

[2,779]—The accompanying sketch (Fig. 1) illustrates a change I made in my automobile engine which increased the power 30 per cent.; thinking the same may interest some of your readers I am sending it to you.

H. W. BARTOL.

Philadelphia, Pa.

### Clutch Jerks on High Speed

Editor THE AUTOMOBILE:

[2,780]—I am a subscriber to your magazine and would like to know what is the trouble with the cone clutch on my car. When I put the clutch in on high speed it does not seem to take hold; it jerks and pounds, whereas when I hold it half in only it does not pound so much. I have oiled it and have wiped off the oil, but it does not seem to have any effect. Would you give me some idea of the trouble?

DECORATOR.

Sarnia, Ont., Canada.

The symptoms of your trouble seem to point to either one of two things. Either the leather has become lifeless and lost all its elasticity or the transmission and the flywheel are no longer in proper alignment.

### May Be Due to a Variety of Causes

Editor THE AUTOMOBILE:

[2,781]—Will you kindly inform me through your columns to what cause the following may be due: A friend of mine has a four-cylinder machine which has been run about 10,000 miles. Whenever the throttle is wide open all the cylinders work fine, but when the throttle is closed only two cylinders work. If you could give me any information on this matter I would greatly appreciate the same.

FRANK MOSHER.

Roberts, Ill.

Owing to the lack of detailed information at hand it is impossible to specificize an answer. The trouble may be due to

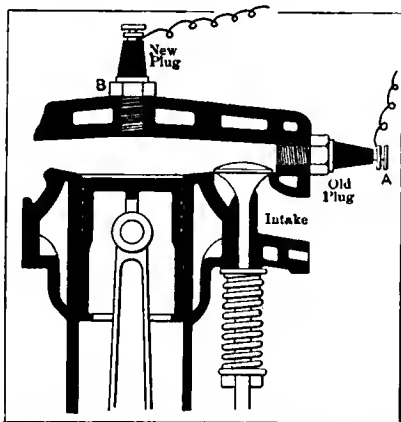
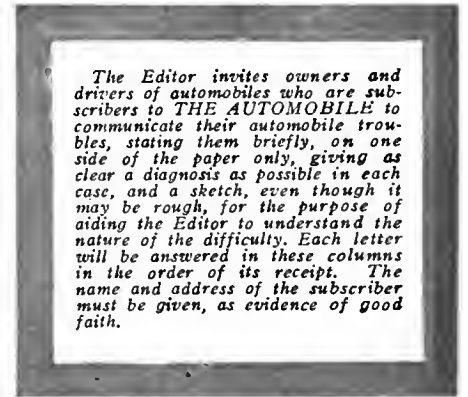

Fig. 1—Illustrating the manner in which a reader increased the power of his motor by 30 per cent.

## What Some Subscribers Want to Know

several causes which may be searched for in the following order: First, test for a spark at all the cylinders while the engine is running at low speed; if this test shows that the current is satisfactory try closing the gaps between the points on the spark plugs in the missing cylinders. If the current is not satisfactory the trouble might lie in a dirty magneto distributor. Having eliminated the ignition system as being the source of trouble there remains the gas supplied to the cylinder which may be the cause of trouble. Examine the intake line at all parts between the carbureter and the intake manifold of the engine for leaks, clean the dirt out of the carbureter and if the disturbing element is not located as one of these, the throttle



standard plumbing or gas fitting parts. As shown in Fig. 2, it will be made up of a double-threaded union, a piece of gas pipe, an elbow and the other parts illustrated. If the specifications in the sketch are carried out a very neat and satisfactory job should be the result.

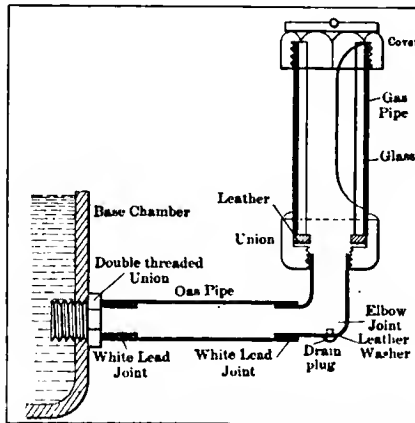

Fig. 2—Method of making and attaching an oil level gauge to the base chamber with standard pipe fittings

lever is apt to close the valve too much, thereby supplying very little gas at low speeds.

### Wants to Install Oil Level Gauge on Crankcase

Editor THE AUTOMOBILE:

[2,782]—I have a car which is lubricated by the splash system. The oil reservoir is located in the lower part of the crankcase and carries the whole supply of oil for the engine. At present it is impossible to tell how much oil there is in the crankcase or if the pump which takes the oil from the reservoir and places it in the splash chambers is working or not, as there is no sight feed on the motor nor is there a level gauge. Will you kindly tell me how to go about installing either a level gauge or some other device to ascertain the amount of oil present in the crankcase at any time? I thank you in advance for the information which I am sure will be of general interest.

R. F. G.

San Antonio, Texas.

A very good level gauge may be attached to the average crankcase with very little expense since it can be made up of

### Hears a Mysterious Rattle Beneath Car

Editor THE AUTOMOBILE:

[2,783]—I have noticed a rattling sound some place in the car and have been unable to locate it. The noise seems to come from some place in the transmission or differentials; it is not a constant rattle, but is only noticeable on first and second gears, and it seems as though the car only rattles in going around sharp corners or up an uneven grade. The machine has only been run about 800 miles and has been well oiled and greased at all times. I sometimes speed the car up on the lower gears and notice that the rattle will cease. If you will give me any information through your columns as to the method of locating and remedying the trouble, same will be greatly appreciated.

A SUBSCRIBER.

Selmer, Tenn.

It is difficult to accurately locate the seat of trouble from the information at hand; we would suggest, however, that you examine the internal floating brake bands.

### Attaching Blame Where It Does Not Belong

Editor THE AUTOMOBILE:

[2,784]—In THE AUTOMOBILE of May 11 there is an article under the head of "The Tempering of Steels." I tried the salt bath on a cold chisel and find that it is not right, making the steel too soft.

Could you give me through your paper a method by which an amateur could arrive at a fair degree of accuracy in the matter of tempering cold chisels? The average thing that is sold in tool kits for a cold



# What Other Subscribers Have to Say

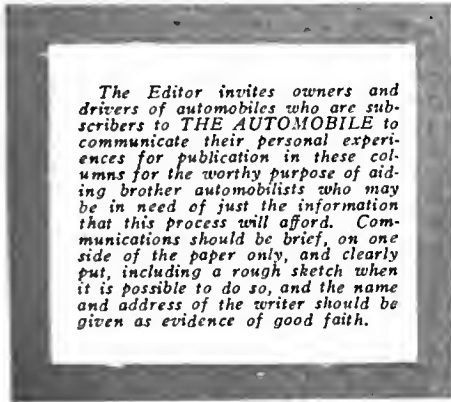

chisel is far from what the name implies. Most of them break with the first blow.  
Perley, Minn. J. E. RICHARDS.

In trying the salt bath in the process of tempering a cold chisel you very improperly blame the bath instead of questioning the quality of the material in the chisel. If the cold chisel is composed of steel including from 60 to 80 points of carbon it will take temper if it is heated to a cherry-red and quenched in either water or a salt bath. It is more than likely that the cold chisel used in your test is some cheap imitation holding carbon below 20 points.

One reason why cold chisels break so readily as referred to by you lies in the fact that they are not "drawn" after they are tempered. The right way to proceed is to heat the chisel to a full cherry-red, quench it in salt water, and thereafter draw the temper of the steel to perhaps a "straw" color.

## Installing a Strainer and Cover on Oil Tank

Editor THE AUTOMOBILE:

[2,785]—I have at my disposal a small shop in which I make little repairs on my machine as they happen to be necessary. The car is rather old fashioned and is not equipped with a very suitable cover on the oil tank. There is no strainer and I am very liable to get foreign matter into the tank. Could you tell me of an easy method of making a cover which will contain a strainer?

READER.

Bath, Me.

The accompanying cut (Fig. 3) illustrates one method of making a cover and strainer for an oil tank, which will be found to be satisfactory and easy to make. A threaded ring is soldered into the tank as shown. A piece of tubing fits into this ring and supports the strainer, which is held in place by the tube, which is turned down as shown. The cover fits over the filler opening and provides a dust-tight seal.

## Fooling Prospective Chauffeurs

Editor THE AUTOMOBILE:

[2,786]—In taking my examination for a chauffeur's license at the secretary's office I was given the following question: Name several methods of running an engine on compression when the low gear is engaged. I could only answer in one way. Will you kindly tell me other methods of doing this?

G. B. M., JR.

Brooklyn, N. Y.

## Unconventional Type of Differential

Editor THE AUTOMOBILE:

[2,787]—I understand that there is a French car made that used a type of differ-

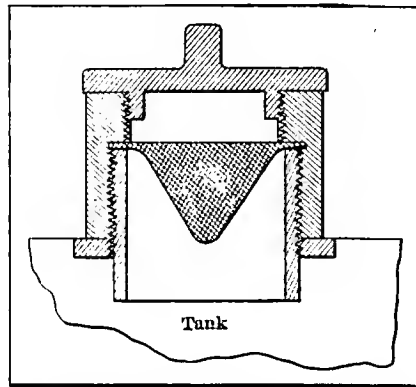

Fig. 3—Showing a home-made oil-tank cover and filler cap containing a strainer to remove the foreign matter from the oil

ential in the live rear axle different from the conventional, inasmuch as the sides of the bevel pinions are approximately the same. Give an explanation of the workings of this type of differential.

Brooklyn, N. Y.

DESIGNER.

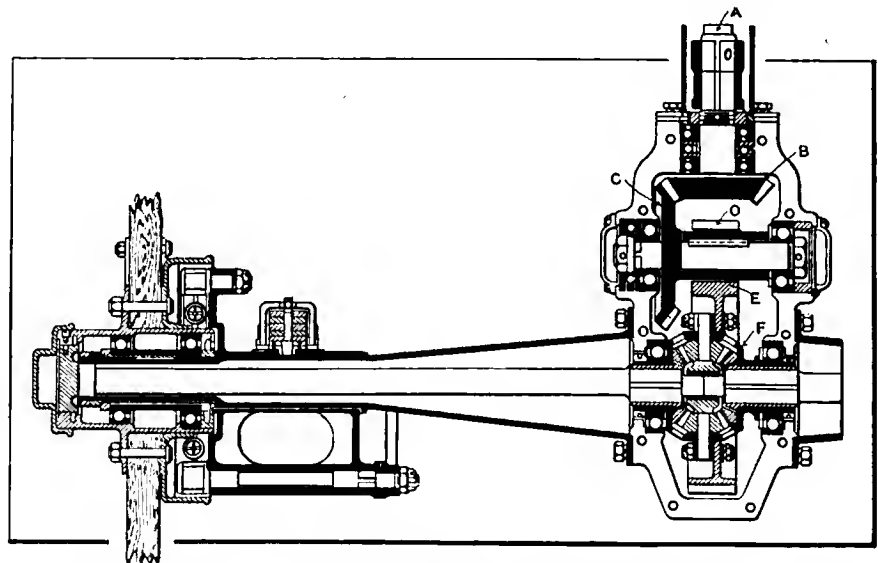

Fig. 4—Section through a live rear axle showing the method of operating the driving pinion by straight tooth gears

The type of differential you probably allude to will be seen in Fig. 4. The driving shaft A taking the power from the motor through the transmission is fitted with load and thrust bearings, being an integral part of the gear wheel B. An intermediary shaft fitted with annular load and ball thrust bearings carries two pinions. The bevel gear wheel C meshes with B and transmits the power to the gear wheel D, which is keyed to the shaft. The straight pinion E is bolted to the boss F, which contains a set of star pinions. The jackshafts, which have square ends, fit into corresponding holes.

## Wants a Little Tire Information

Editor THE AUTOMOBILE:

[2,788]—I am taking the liberty of asking you a question in regard to a tire for my machine. Would I require a smaller tube for the tire if I used a liner? I use 30 x 3 1-2 inch tires and would like to know if it would be right to get a smaller tube if I should use the liner, or if the same size would be suitable. Any information would be appreciated.

Ed. C. BATES.

Clarksville, Tenn.

The same size tube would be required whether you used the liner or not.

## Wants Information with Reference to 1912 Specifications

Editor THE AUTOMOBILE:

[2,789]—Can you give me any information in regard to the specifications of the 1912 Cadillac? Will they have a four-speed transmission and will they have a 4 1-2 x 5 motor? Will the wheelbase be longer?

Corvallis, Ore. WALTER H. KLINE.

Up to the present moment the company has not made any announcement as to its 1912 models, and no doubt you will be able to get the information you desire from the factory direct.

# Meeting Recurring Troubles

## Presenting a Series of the Most Probable Cases

A series of co-related short stories, accompanied by diagrams and characteristic illustrations, indicating the nature of the troubles that are most likely to happen to automobiles, discussing their causes and effects, all for the purpose of arriving at a remedy. It is the aim, for the most part, to show how these troubles may be permanently remedied, and as a secondary enterprise it is indicated how the automobilist can make a temporary repair, thereby enabling him to defer the making of a permanent repair until a convenient time arrives.

**THE BUTTERFLY VALVE.**—The throttle valve is the valve which, in conjunction with the spark timer, governs the speed of the car and relatively the amount of fuel it consumes. This valve is of necessity positive in action and must give a wide range in the size opening of the inlet pipe. There are two types of throttle valves which are in general use at the present day; they are the butterfly valve, as shown in Fig. 1, and the plug type, which is not so often used on motor cars. The butterfly type of valve is arranged so that a rotating metallic flap (the butterfly), which is actuated by a spindle, can be turned so that it shuts the pipe completely and thereby throttles the inlet pipe. The opening is a maximum when the butterfly is parallel with the pipe. In this case the opening is not obstructed except by the thin metal disk which forms the valve and which is so narrow that the flowing gases are not checked to any appreciable extent. Generally the throttle valve forms a part of the carburetor and the spindle is continued up a distance above the inlet pipe to allow room for a governing lever. To this is attached the throttling mechanism, which, of course, is controlled from the steering wheel throttle lever.

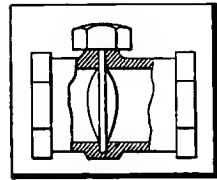

Fig. 1—Illustrating a common form of butterfly throttle valve. The valve is often punctured by a small hole so that the engine will just turn over when the valve is closed

The plug type of throttle valve is found for the most part on steam apparatus. It is a cylinder or cone in which there are either a number of slots or in other cases one. The cylinder is hollow and can turn on its axis or can slide longitudinally. The slot is arranged so that as much of it as is needed can be exposed, allowing the fluid to pass through. The opening is a maximum when the whole slot is exposed or a minimum when the slot is behind the bushing. The advantage of this type of valve is the great nicety to which it may be adjusted. This advantage is possessed to a great degree by the butterfly type as well.

**CARE OF STUFFING BOXES.**—No matter where the mechanic's field of activity is located, whether in a garage equipped with machinery or in the country home, where the machinery of the garage is used to pump the water and per-

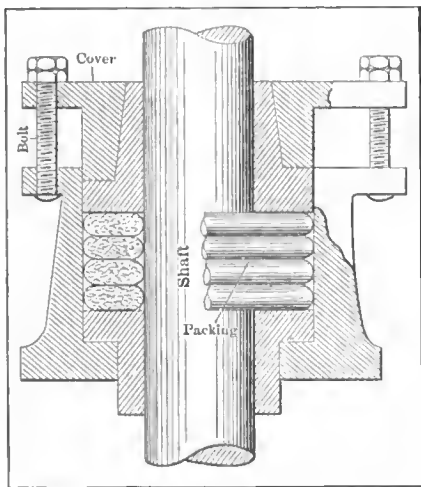

Fig. 2—Simple packing or stuffing box which may be adjusted by the tension on the bolts

baps light the house, he is going to strike at some time or another a stuffing box which needs repacking. The average stuffing box will hold its packing in a water-tight or gas-tight condition for a great length of time before it needs replacing. When the time does come to replace the packing it is not as a general rule necessary to send the box to a repairman, but the work can be done at the garage by anyone who understands the construction of these devices. The accompanying cut (Fig. 2) gives the usual form in which the stuffing boxes are made. The cover is always made removable and the packing can be taken out after the cover has been removed, new packing can then be placed in position. The packing used will, of course, depend upon the nature of the service to which the stuffing box is to be adapted. A leaking stuffing box does not always have to be repacked, as there is an easy method of adjustment to tighten the pressure on the packing, which will stop leakage if the material used for packing is in fair condition. In the type shown in the illustration, if the nuts on the ends of the bolts are tightened the packing will be squeezed against the shaft and the leakage will generally be stopped. In tightening the adjustment of a packing box the nuts should not be tightened any more than is required for a non-leaking joint, for if this is done a large amount of friction will ensue which helps to cut down the efficiency of the machine besides beating the bearing and wearing the parts.

**SHEET METAL JOINTS.**—There are two types of sheet metal joints which are in general use, they are the lap joint and the butt joint. To resist a pull of any amount the butt joint possesses the greater strength, as in order to fail two rows of rivets must be sheared or the butt strap must fail by tension. An examination of Fig. 3 will show the relative merits of the two systems of making joints and give an idea of the comparative strengths of the two. The joint most used in automobile practice, in such places as the channel automobile frames, is the butt joint. This type of joint may be welded or held in place with a butt strap, as the illustration shows. Very often in heavy work there are two butt straps employed which give a large amount of additional strength, in this case the rivetting is either double or triple. It is not used in automobile work, however, as there are no requirements for it.

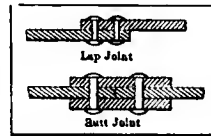

Fig. 3—Showing a double riveted lap joint and a double strapped butt joint—two common forms of sheet metal joints

**RELATIONS BETWEEN TIRE PRESSURE AND FLEXURE.**—The following tables show the amount of flexure of the tires taken promiscuously, as compared with the size of the tire at the top:

Tests on Rear Wheel of Empty Seven-Passenger, Six-Cylinder Touring Car Fitted with 37 x 5 Plain Tread Tires.

Pressure in pounds per square inch	Measurement of tire at top in inches	Measurement of tire at bottom in inches
105	4 9-16	4 1-16
100	.....	4
90	.....	3 7-8
80	.....	3 13-16
70	.....	3 25-32
60	.....	3 3-4
55	4 1-2	3 3-4
50	.....	3 11-16
40	.....	3 5-8
30	.....	3 7-16
20	.....	3 1-8
14.7	.....	2 13-16

The extreme widths of the tire at the pressure that the tire was found to contain, viz., 55 pounds, measured with a pair of calipers, were as follows: Top, 5 5-16 inches; side, 5 1-4 inches; bottom, 4 3-4 inches.

Tests on Front and Rear Wheels of Limousine Fitted with 36 x 4 1-2 Tires.

Pressure in pounds per square inch	Front Tire Top	Front Tire Bottom	Rear Tire Top	Rear Tire Bottom
90	4 1-16	3 3-8	4 1-16	3 3-8
80	.....	3 1-4	.....	3 5-16
70	.....	3 7-32	.....	3 1-4
60	.....	3 3-16	.....	3 3-16
50	.....	3 1-8	.....	3 1-16
40	.....	.....	.....	2 7-8
30	.....	.....	.....	2 5-8
20	.....	.....	.....	2 3-16
14.7	.....	.....	.....	1 13-16

**BEST WAY TO "SET OUT" PISTON RINGS.**—Cast-iron piston rings may be set out by means of a pie hammer, just as was formerly done with steel steam rings. The only thing is that the work must be done more slowly and more carefully. There are machines on the market in which the rings are turned concentric, and then made elastic enough to spring out and hold against the cylinder walls by hand-piecing on one side of the ring. The number of examples of this are few in America, but a number of French car makers use it.

**Gears and Pinions Must Have Durability.**—The great factor in the design of involute gears and pinions is the angle of obliquity or pressure. This angle can not be made standard for all sizes of gears as for instance in using a pinion of ten teeth with the common pressure angle of 14 1/2 degrees the flanks of the teeth will be undercut too much and the tooth materially weakened. Take for example Fig. 4, which shows a segment of a gear of ten teeth, four diametral pitch. The angle of obliquity causes the teeth of this pinion to be undercut to such a degree that its durability would be considerably shortened, hence gears that are to do heavy work may require a greater angle of pressure than 14 1/2 degrees if they are to run with a pinion of less than 12 teeth.

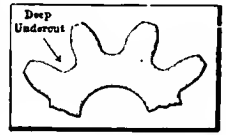

Fig. 4—Showing gear with excessive undercut

In the choice of an angle of pressure some idea of the correct angle may be obtained from Fig. 5, which is taken from a ten-tooth gear, four pitch, the angle of pressure being 22 1/2 degrees. The greater strength of the gears in this figure is readily seen. In any case the angle can not be much more than 32 degrees and have the addendum of the teeth, the ordinary height which is equal to one of the diameter pitches or the module.

**LIQUID IN MIXTURE IS MISCHIEVOUS.**—Gasoline as light as octane will vaporize sufficiently well in the carburetor and the intake line to justify its use in automobile work. The heavier products, however, vaporize but poorly and cause the most annoying crankiness on the part of the motor due to the deposit of carbon, which can be so often traced to these fuels. Octane is just about on the border line and a gasoline which contained any quantity of it would be a very poor quality indeed, a trace of it will be found to be present as a rule though and if it is not in too large quantities it will vaporize sufficiently well to allow it to just pass.

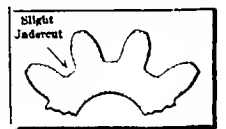

Fig. 5—Segment of 10-tooth, 4-pitch gear

The accompanying cut, Fig. 6, will show a common form of trap which may be placed in the intake line. This trap will catch the liquid globules as they pass through the pipe and drain them into the recess which forms the lower part of the trap. The liquid strikes the baffle plate, which protrudes into the intake pipe and fall through the hole into the retainer located below. If the liquid gasoline should pass into the cylinder itself and burn there the result would in time be a deposit of carbon on the piston head or some other part of the combustion space. This carbon would in time start to glow and thus cause pre-ignition, and hence a pound in the motor.

A set-bolt placed in the bottom of the trap plays the rôle of a drain and in case of its becoming filled it can be emptied by means of this arrangement. To elaborate on this idea it is only necessary to hot-water-jacket the reservoir and thereby enrich the mixture with the gas generated by the heated n-octane or pentane, as the case may be.

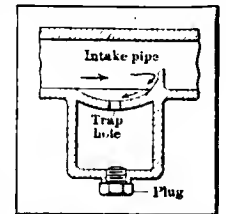

Fig. 6—Common form of gasoline trap inserted in intake line

**REMOVING PISTON RINGS FROM PISTONS.**—In removing piston rings, lay down on the surface of the piston three or four strips of very thin flat steel. Raise the first ring out of its groove, either by expanding it by means of special tongs or by simply picking it up as best you can. Then slide the flat strips of steel under this and slide the ring along on the strips until the top is reached, when it may be picked off. The reason for the strips of steel is, first, to allow the rings to slide easily, having a uniform surface to slide on, and, second, to prevent the second and later rings from drooping into the open grooves made by the first ring. It is not always convenient to take the bottom ring off first, and even if it were done there would be the other rings to pass over, which is just as difficult as passing over an open ring space. Care should be taken not to scratch the delicate surface of the piston rings with the hard pieces of metal.

**OIL LEADS OFTEN CLOG.**—In the force-feed system of oiling there is generally far more oil supplied to the motor than is absolutely necessary. The usual methods of force-feed oiling do not depend altogether on the force-feed system to do all the lubricating of the machine, but have an auxiliary splash system. Many very fine systems, however, rely wholly on the force-feed and while there is as a rule a good margin of safety left when the system is designed, a plugged-up oil lead may have very serious consequences if not detected after a time. There are several ways of conducting the oil from the mechanical oiler through the motor, the most common being that of leading the oil to the main bearings and from there through the drilled crankshaft up to the lower connecting rod bearings. The force pump is considerably aided by centrifugal force in sending the oil on its way to the crank bearings, so that when the oil reaches this point it has the necessary momentum to send it up into the wrist pin bearing.

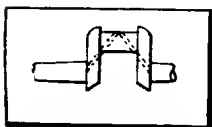

Fig. 7—Slanting oil leads cut in crankcheek and pin, very often used in conjunction with centrifugal ring

Or, if the leads are not drilled into the crankshaft they are led to an oil ring called a centrifugal oiler, which is a ring resting on the crankshaft. The ring is arranged with a rim so that as the oil is sent to the perimeter by centrifugal force, it is retained there, while the oil which is opposite the hole in the crankcheek is forced through up the slanting grooves into the lower connecting rod bearing. The method of drilling the oil leads through the crankshaft depicted in Fig. 8, is of course, not adapted to the centrifugal ring, but is intended for cases in which the oil is sent through the crankshaft from the main bearing by means of an oil hole and from there is forced up to the various leads until it reaches the wrist pin.

A stoppage of the oil flow within the crankcase itself would not be such a serious matter at medium speeds, as there is always an oil vapor in the crankcase which is generated by the swiftly revolving cranks. Should the new supply be cut off for any length of time though, the results would become very serious if heed were not paid to the warning signs which would be given forth by the heating motor. A sudden loss of power and perhaps pre-ignition causing a knock while turning at low speeds would evince itself if the case were serious enough to cause a shortage of lubricating matter to one of the bearings.

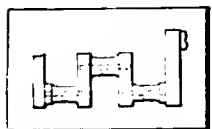

Fig. 8—Oil leads in crankshaft used in force feed system where oil is pumped up as far as wrist pin bearings

drilled all the way through the various pieces of metal and are then plugged to the required depth by means of a screw. When the leads become stopped up within the crankshaft or crankcheek these openings prove themselves a real boon, as the screws simply have to be removed and a copper wire run through the hole to remove the residue which has been deposited therein. A warning may be read in the fact that this impediment to the flow of the oil will be found to be a thread of cotton waste much more frequently than an

impurity which was present in the oil when bought.

The reason for this oil waste being found so often in the oil circulating system is that when cleaning out the tank or other parts of the machine cotton waste will be employed to wipe off the superfluous matter. This waste will leave threads on the rough walls of a casting, which work loose and collect in some place where they will eventually give a great deal of trouble. When using waste around any part of the machine which comes in contact with moving parts it should be very carefully removed so that accidents of this nature do not occur.

**DRAINAGE TROUBLES WILL CROOP UP.**—The makeshift drainage trap which is often slapped into place by an incompetent or perhaps an amateur plumber, which often amounts to the same thing, is as a rule a rather ineffective piece of mechanism. The greatest mistake is to put a bird in the pipe under a drain and expect it to perform the office of a trap in a satisfactory manner. It might do so for a time but eventually will cause trouble. Smells are bound to arise from a drain if it is not adequately protected from them by some means of sort of baffle, a water-sealed bell by preference.

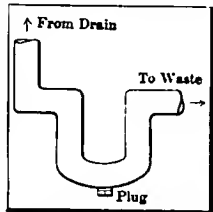

Fig. 9—An amateur's job commonly seen. A very poor form of trap

ed in careless work. Fig. 10 shows the bell type. The drainage first flows through a strainer so that no large pieces of solid matter are allowed to flow into the drainage pipe in the first place, so that there is a very small chance for the system to be clogged in this manner. The water is poured in as shown until it covers the edges of the bell baffle, thus effectually sealing the waste pipe so that no smell can pass from the foul pipe up through the strainer into the garage or whatever is being drained by the system. The cup formed by the casing of the trap below the bell can be very readily cleaned out by removing the strainer cover and by means of a wire or small scraping tool the sediment can be taken out. This should be done very often so that the bell trap does not forfeit its own purpose and become a trap for waste matter instead of a device to prevent foul atmosphere in the space which the drainage system takes care of.

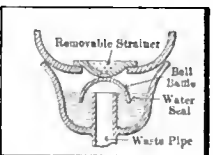

Fig. 10—Bell stench trap used in careful drainage work to keep dangerous odors from the room drained

**ACTION OF THE CENTRIFUGAL PUMP.**—The action of the centrifugal pump is practically the exact reverse of the action of the ordinary water wheel with which we are nearly all familiar. The efficiency of the water wheel and the conditions under which it acquires itself with the greatest amount of satisfaction are the same as those under which the water turbine is found to be of the greatest use and satisfaction, that is, where there is a positive and continuous flow to be maintained against a back pressure or head which is not excessive.

The power given to the shaft of the centrifugal pump is transferred to the water by means of a series of radial vanes which are illustrated in Fig. 11, showing a section through the pump chamber. The water is led to the center of the revolving group of impeller vanes and is picked up by the slower moving parts at this point without shock or noise. It is then conducted by means of centrifugal force to the outer ends of the vanes. During the flow to this point the water has accumulated a greatly accelerated motion, and pressure until it has absorbed all the power which is transmitted to the pump shaft and has not been lost in mechanical ways, as in overcoming friction, etc. The most satisfactory pump will be the one which has given the water the maximum velocity and pressure with the minimum amount of noise, shock and friction.

The water pump on an automobile is generally of the centrifugal type, and for the use it is almost ideal since there is no appreciable head to pump against and the velocity of flow is required to be somewhat high. The water pump is generally driven on a full-time gear ratio, that is, the speed of the pumps shaft is the same as that of the crankshaft. Very often the magneto is driven off the same shaft as the water pump, the shaft in most cases running longitudinally with the motor. There are a few notable exceptions to this, however, the shaft being

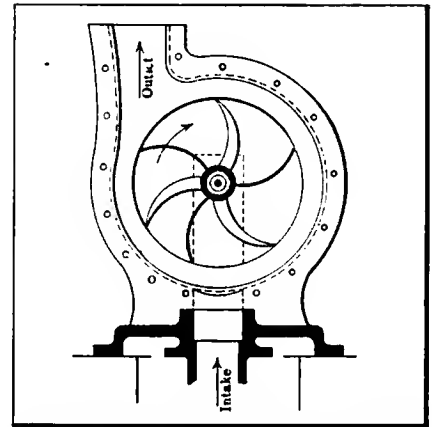

Fig. 11—Common form of centrifugal water pump, much used on automobile water circulating systems

placed laterally across the front end of the engine.

In a case where the pressure required is high it is obtained at the expense of the velocity. The speed of the water is slowed down in an annular diffusion space which is designed so that the contraction is as gradual as it is possible to make it so that there will be no needless waste of energy in making eddies or whirlpools within the casing. With a proper design of the diffusion space and volute it is possible to transform nearly all the energy of velocity into that of pressure so that the pump is capable of working against a normal head without any difficulty if it is well designed. The automobile water pump has not much head to overcome, as a rule, so that the pump can be designed to give a very satisfactory velocity through the water jacketing. This velocity is of great importance, as the effectiveness of the cooling fluid depends to a large degree on the rapidity with which it is renewed.

Since the continuity of flow is of great importance in the automobile water pump it is necessary to furnish a uniform supply of water to all the parts of the inlet or suction opening of the impeller, for unless all the impeller vanes get the same supply of water the continuity will be interrupted.

**A TOOL OF GREAT UTILITY.**—Clamps are of such universal use that it is not usual to find a garage or any shop where there is any repairing done at all which is not equipped with a number of these instruments. In purchasing clamps great care should be taken that they are adapted for the work to which they are to be put. The accompanying illustrations show two types of these tools.

The clamp shown in Fig. 12 is a cheaper tool than that shown in Fig. 13. It is a very good tool, however, and is very satisfactory if it is able to perform the work. For heavier work, though, the more costly clamp will probably be required. In wood working, tire repairing, and like odd jobs, the lighter of the two will be perfectly satisfactory. In tightening the clamp care should be taken that it is not fastened to some delicate surface which will be damaged by the pressure exerted. If there is any risk of this a piece of soft wood may be inserted which will remove the danger to a large extent. One of the great objections to the type of clamps generally on the market is the winged nut, the projections on which are so small that it is not possible to bring it to the required tightness by hand; in this case a wrench will be required to overcome the difficulty.

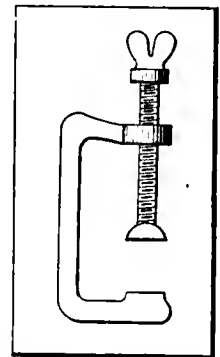

Fig. 12—Type of clamp used in lighter work, such as wood working

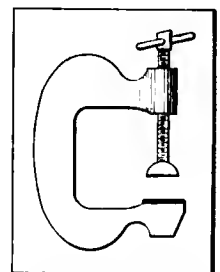

Fig. 13—Heavier clamp employed in metal working or any heavy work where such a tool is required

# Carbureters with Sunken Jets

## The Tendency in Modern Foreign Practice

*This article, which appeared in "La Vie Automobile," discusses the tendency in modern carbureter construction, utilizing several different makes of carbureters as examples in dealing with the principle of the sunken jet. The author endeavors to show what must be done to make a carbureter automatic.*

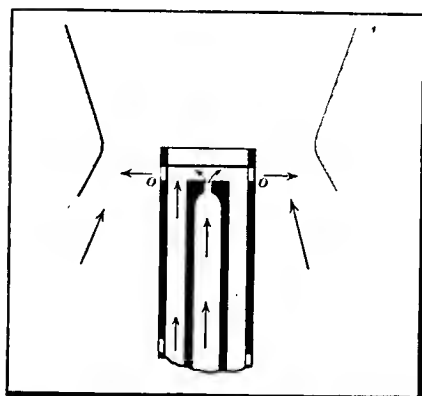

Fig. 1—Section through the Claudel jet showing the air passage way around the jet proper

**C**ARBURETERS with automatic air adjustment seem to be on the decline, according to the author, which no doubt applies to the types manufactured in Europe. The majority of carbureter "specialists" have dropped that idea. The vogue now is for carbureters with a fixed air intake without any adjustment for the air or gasoline

and without adjustment for the automatic air intake. The modern method is the regulation of the gasoline automatically.

It is conceded that all methods that assure automatic operation will give the same results; nevertheless the automatic regulation of the gasoline seems to prevail owing to its simplicity and the fact that it eliminates all moving parts.

A mechanism, no matter how delicate it may be, can run for a long time without getting out of order if made with care and fitted methodically. Unfortunately every driver loves to tinker with his carbureter, and more than ever when his ideas of carburetion in general are a negligible quantity. The motor may knock a little; immediately, not enough gas! and he proceeds to close the valve or stop up the additional air ports. With what result? The motor knocks just the same and instead of using 15 gallons it uses 25 gallons. If the motor heats because the fan belt slips or because the ignition has not enough advance, or any other reason for a matter of that, the carbureter is blamed. Too much gas! The jet is given a blow to close the hole and the air holes are enlarged. Result: The motor no longer responds

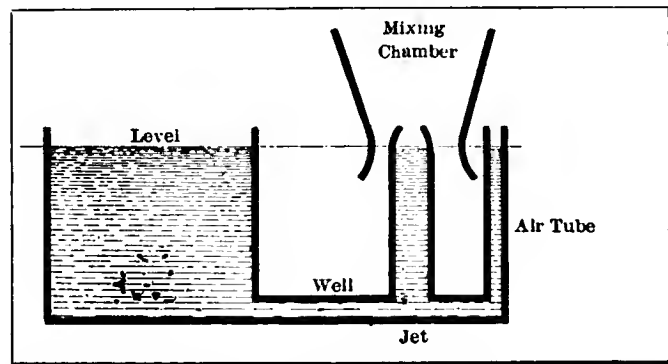

Fig. 3—Section through vapor carbureter, showing the method of sinking the jet under the level of gasoline

and loses its vivacity. It is a difficult matter to make some drivers understand that for the most part it is a physical impossibility for the carbureter to cause the motor to knock or overheat or at any rate that the influence of the carburetion on these two phenomena is extremely small and should not find a prominent place in daily practice.

As it is difficult to inculcate these ideas into drivers' heads,

it remains to give them carbureters that they cannot put out of order owing to the absence of adjustments. Then the only reason for the jet to be taken apart should be initial adjustments or cleaning. Even then if a fine wire gauze filter is interposed in the gasoline circuit it should never be necessary to remove the jet, and if this part were fitted with a difficult means

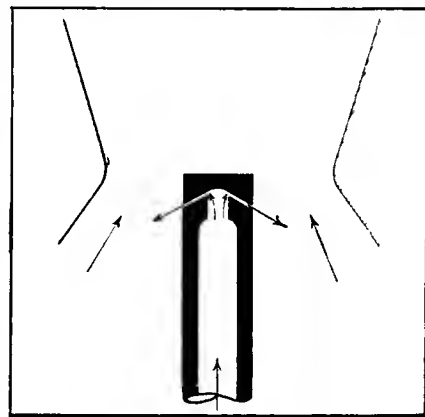

Fig. 2—Section through another type of jet in which the outlet is deflected downwards

of taking same apart the driver would have little desire to tinker, thus avoiding troubles that might arise from his lack of knowledge.

### Automatic Methods of Regulating the Gasoline

It has for many years been thought impossible to realize an automatic system of controlling the gasoline flow without utilizing any moving part that is affected by the depression caused by the motor. The problem is shortly this: A way has to be found of preventing the gasoline from surging from the jet in too great quantities when the speed of the motor is increased, or, to be more exact, when the depressions on the jet are increased.

Several systems have been proposed in the last few years which can be divided into two classes: placing a braking effect on the gasoline, and the flooded jet.

The Claudel is the prototype of the first system in which an ordinary jet is surrounded by a funnel or air circle. The air and the gasoline leave the upper part at the same time through small holes drilled laterally. It will be understood that at

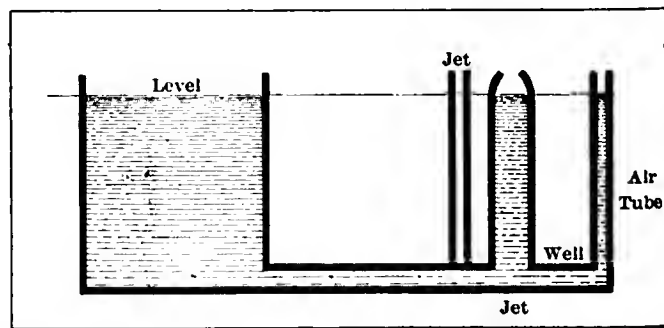

Fig. 4—Section through the Claudel carbureter, showing the well containing the jet and the compensating jet alongside

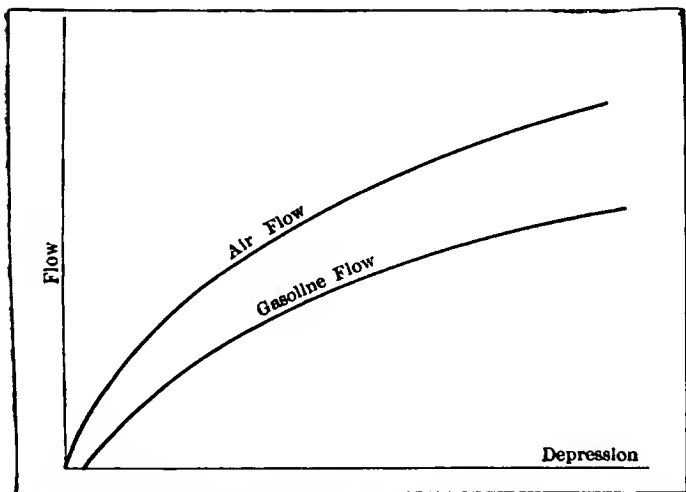

Fig. 5—Diagram representing the differences between the flow of air and gasoline in an ordinary carburetor

high speeds of the motor the air which is forcibly aspirated in the funnel will abut at the end of this chamber, and set up a counter-pressure at the orifice of the jet. It follows that the air chokes the passage of the gasoline and prevents an excess of gasoline at high speeds. On the other hand an energetic mixing is produced in consequence and the gasoline leaves the orifices O in Fig. 1, divided in minute particles, which facilitates its subsequent vaporization.

An analogous system but of simpler construction is shown in Fig. 2, which consists of directing the orifices of the jets so that they are opposed to the direction of the incoming air current. The angle of inclination must be determined by practical tests. At high speeds the air current tends to draw the

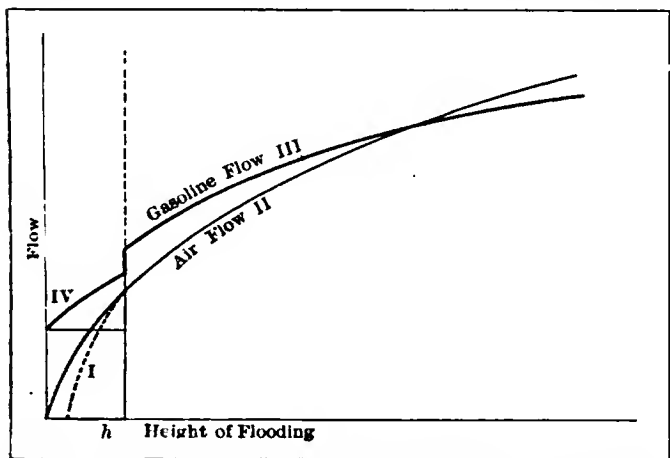

Fig. 6—Curves taken from tests of the Vapor carburetor, the dotted line I indicating the flow of gasoline up to the time the well floods

gasoline from the jet and to push it back at the same time.

The question arises then as to the point where compensation exists, leaving the mixture more or less constant, and this is more difficult to estimate. It is possible to arrive at practical results with the Claudel carburetor, which is in itself an example or proof. But an absolute automatic action is not attained by this method, as may be seen from the slow picking-up qualities and the loss of power on hills. In spite of its simplicity this system has been abandoned by its most staunch adherent, Claudel, who has gone over to the flooded jet.

Flooded Jets

As the name implies, this is a jet placed below the level and through which the gasoline tends to flow constantly on account of the difference in levels. In order to eliminate a mechanical means of closing the jet when the motor is not running it is placed at the bottom of a well, as shown in Fig. 3, the sides

of which are slightly higher than the level of the gasoline. When the motor is at rest the well fills up to the level of the gasoline, completely drowning the jet and preventing it from giving off any more gasoline. An air passageway in communication at one end with the base of the well and at the other extremity with the exterior allows air to pass in and carry with it the gasoline given off by the jet.

When the motor is stationary the well and the passageway, as has been shown, are filled up to the corresponding height of the level in the float chamber. As soon as the motor is started a depression is produced in the mixing chamber or throat. The gasoline tends to rise in the well to a height equivalent to this depression. But, as the sides of the well are scarcely any higher than the level, the gasoline leaks or dribbles along the walls of the well and is carried along, at any rate in part, by the lapping effect. At this moment the carburetion is very insufficient because the gasoline that trickles along the outside walls of the

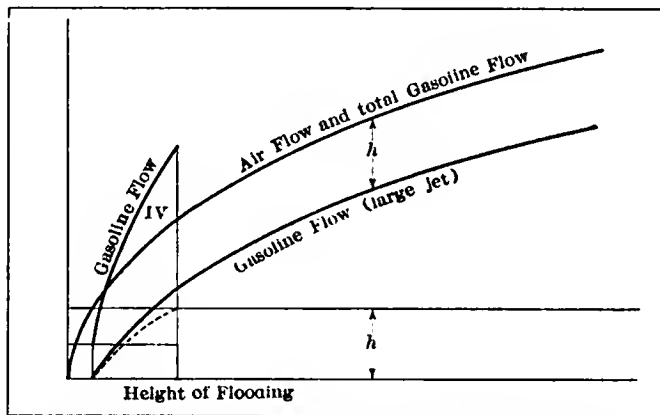

Fig. 7—Curves taken from tests made with a Zenith carburetor

well is not vigorously vaporized and carried in by the current of air. The flow of gasoline is then that of an ordinary jet acted upon by the depression which obtains at the orifice of the well. According to the degree that this depression increases the level decreases in the air passageway and as soon as the depression is equal to the column of gasoline which is flooding, the jet, the air will enter the passageway, carrying with it the gasoline that remains in the well, and leave the extremity of the latter, passing into the mixing chamber.

At that moment there is a discontinuance of the procedure, as the depression which exists in the mixing chamber makes itself felt in the base of the well as soon as it is empty. And the moment the gasoline is taken from the well the depression, which was as great as the height of the flooding, suddenly becomes double. Further the flooded jet does not come into operation until the depression is sufficient to expel the gasoline

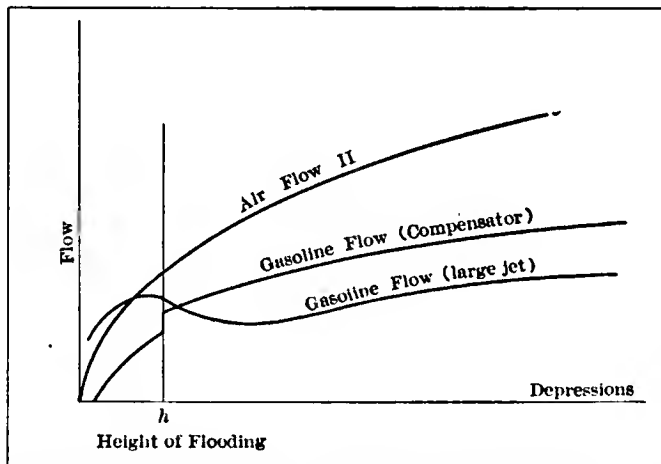

Fig. 8—Showing the flow from the large and compensating jets of the Claudel carburetor, together with the air flow



from the well; but at that moment it is stirred up, leaving the orifice of the well, and then intermingles with the air. The gasoline thus expelled, which operation is not the least of the advantages of the flooded jet, makes an effective combination, producing a good mixture even with small depressions, which is equivalent to slow-speed running for picking up and running on a grade.

With the engine running slow and the car standing still it is necessary to resort to an artifice. In the Vapor carbureter a small lead not shown in the illustration, Fig. 3, takes the gasoline at the mid position of the well and atomizes it on the flap of the butterfly valve. Until the well has been thoroughly primed, and it is always half so, the jet sprays into the mixing chamber. Fig. 6 shows the relation of the curves of the gasoline flow, which more nearly approaches the air flow than is obtained in ordinary carbureters, the relative curves of which are shown in Fig. 5. It is impossible to arrive at perfect compensation with this type of sunken jet, but on the whole a good result is obtained.

As a matter of fact the delivery of the gasoline is caused to leave the axis of the abscissæ from another point; in other words, it is displaced horizontally instead of vertically, which is necessary to assure a perfectly theoretical compensation. Too much importance must not be attached to these reasonings, which are rather in the nature of indications than scientific truths.

Another type of flooded jet obtains in the Zenith carbureter, which was probably the first of this kind. In this carbureter the sunken or flooded jet, which is not submitted to the depression and consequently has a constant flow, is in communication with an ordinary jet and the combination of the two permits a theoretical automatic operation which is at the same time practical. At very slow speeds and when the well is not primed the gasoline leaks not only out of the large jet but also out of the cap. The large jet and the compensator therefore deliver both at the same time. Unfortunately, however, the gasoline that flows does not become entirely utilized in the suction unless a hot air intake arrangement is provided. In order to have the gasoline thoroughly atomized it is precipitated on to the flap of the butterfly valve and as it is given off by a sunken jet it is delivered in constant and equal quantities independent of the depression. The horizontal line in Fig. 7 denotes this. The total gasoline flow is represented by the curve IV. This curve is purely theoretical, as all the gasoline is not carried along. From the moment that the well is filled the air and gas curves become confounded.

The new Claudel carbureter is very similar to the preceding ones, but it is very difficult to theoretically explain its workings. As a matter of fact a sunken jet under the influence of the de-

pression and identical to the Vapor shown in Fig. 3 is joined with another jet similar to the older type as shown in Fig. 1, which means in other words that the old Claudel jet is combined with a sunken jet.

It is clear that this disposition is not entirely automatic in operation. In fact, a given depression above the choke throat or a given flow of air and a given flow from the sunken jet do not correspond to a fixed flow from the large jet. This flow is variable according to the aperture of the choke. It is not possible to represent the flow of this jet according to the workings of depressions in the mixing chamber before arriving at the throat. Therefore a curve is given which will approximately correspond to the working of a motor giving off full torque. In practice this lack of automatic operation is perhaps very small; in fact, it may be a negligible quantity under certain conditions. The duty of the large jet is above all of importance at slow speeds; that is to say, when the flooded jet is hardly operating at all. The weak point in the old Claudel is thus eliminated—viz., slow picking-up qualities—by the addition of the sunken jet. A careful adjustment permits one to arrive at good carburetion for all points of the sector and all practical speeds. This incomplete article shows the new field that has been opened up of late years in carburetion.

## A Suggestion in Fan Design

*It is no uncommon sight in the Winter months to see radiators on cars partially covered with strips of metal or leather to prevent the water from getting too cold.*

THE radiator has to perform the duty of dispersing some of the heat contained by the water after it has fulfilled its task of maintaining the cylinders at a uniform temperature. It stands to reason that the maximum efficiency which will obtain at a given temperature will diminish if the temperature of the water is raised or lowered materially. This phenomenon is exemplified when the fan belt breaks or slips, in which case, if the outside temperature of the atmosphere is high, the water will in all probability boil. Therefore, if the fan is so made that the pitch of the blades can be altered so as to cause a greater or lesser suction, it should be possible to maintain the circulation water at a uniform temperature all the year around. One method of accomplishing this can be seen in the accompanying illustration. The fan bracket carrying the blades and pulley wheel may be cast from aluminum in the manner shown at B. The blades proper are made from sheet aluminum, the sides of which are given a slight bend in the manner indicated. It is possible then to attach the blades to suitable feet which pass through a hexagonal boss, being held in position by spring washers and nuts. The amount

of pitch given to the blades will determine the suction through the radiator.

There would be no difficulty in reversing the pitch of the blades in Wintertime and forcing hot air upon rear side of the radiator, thereby warming it to counteract the low outside temperature. The pitch could be altered without dismantling the fan in any way, as the nuts holding the blades in position are accessible from the rear of the bracket.

The design of a fan in the first place is largely a matter of trial and error, based on experiments until a compromise is obtained which most nearly conforms to the given conditions. Another advantage possessed by this fan is that three other blades may be removed without interfering with the balance in any way. From some tests on this type of fan it was found that by altering the pitch slightly and removing three of the fan blades the circulating water

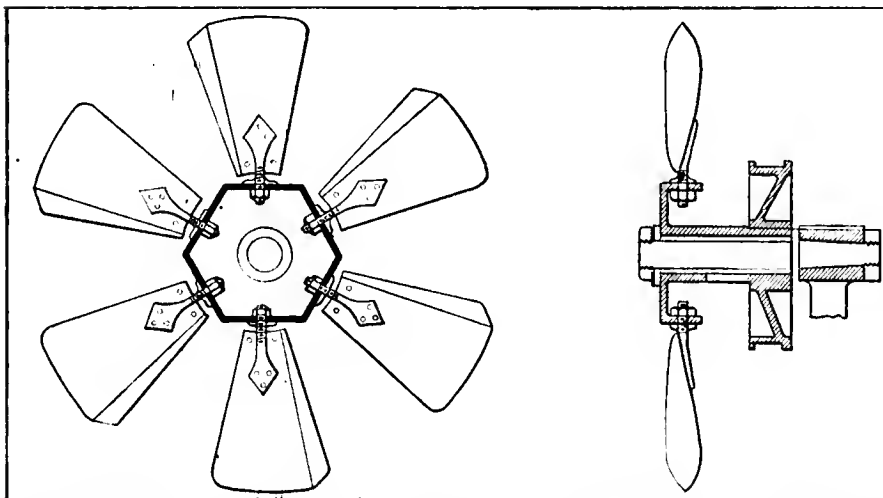

Type of fan, which permits alteration of pitch to maintain the water at an even temperature despite the variations of atmospheric conditions

would retain practically the same temperature in Winter as in Summer.

It may seem difficult to some to determine whether an alteration in the pitch of the blades has increased the suction of air or has caused it to decrease. A thermometer test will show the difference in temperature, but a rough and ready test can be carried out by placing a handkerchief or piece of paper on the face of the radiator, and the ease with which the article can be removed when the motor is running will act as a guide, providing the fan belt has the requisite amount of tension to eliminate slip.

It is of vital importance that the hood should have a good seat upon the ledge of the radiator if the fan is to perform satisfactorily. The practice of fitting a strip of rawhide on the ledge to prevent rattling sometimes leaves spaces for the air to find an inlet which should pass through the interstices of the automobile radiator.

### A Novel Motor Wagon Load

The accompanying illustration depicts the bronze statue which has recently been cast in Paris, and which is intended to be erected in the town of Nantes. The statue is no less than 17 feet high, and weighs about 3 1-2 tons. Seeing that it could not be conveyed to its destination either by rail or river, the problem of its transport presented some difficulty. However, after some negotiations, the Aries Automobile Company of Villeuve-la-Garenne, Paris, undertook the work with one of their motor wagons, which, with only a single person in charge, successfully conveyed the statue to the town of Nantes in three and one-half days and entirely without accident. The feat is being duly appreciated in freight automobile circles on account of the difficulties involved.



How a huge statue was transported from Paris to Nantes

**TIRE DAMAGE BY CAR TRACKS**—One of the great causes of rapid tire wear is the penchant of some chauffeurs to run their machines on the tracks of trolley car lines. Tracks of any description should be avoided as much as possible by careful drivers.

# Calendar of Coming Events

## Handy List of Future Competitive and Show Fixtures

### Shows

- Jan. 1-5, 1912.....New York City, Grand Central Palace, Annual Show, Automobile Manufacturers' Association of America.
- Jan. 6-13.....New York City, Madison Square Garden, Twelfth Annual Show, Pleasure Car Division, Automobile Board of Trade.
- Jan. 10-17.....New York City, Madison Square Garden, Annual Show, Motor and Accessories Manufacturers.
- Jan. 10-17.....New York City, Grand Central Palace, Twelfth Annual Show, National Association of Automobile Manufacturers.
- Jan. 15-20.....New York City, Madison Square Garden, Twelfth Annual Show, Commercial Division, Automobile Board of Trade.
- Jan. 27-Feb. 10....Chicago Coliseum, Eleventh Annual Automobile Show under the auspices of the National Association of Automobile Manufacturers.

### Race Meets, Runs, Hill-Climbs, Etc.

- Aug. 12-18.....New Orleans-to-Memphis Good Roads Tour, New Orleans *Picayune*.
- Aug. 17.....St. Louis, Mo., Reliability Run, Missouri Automobile Assn.
- Aug. 25-26.....Elgin, Ill., Stock Chassis Road Race, Chicago Motor Club.
- Sept. 1.....Oklahoma, Reliability Run, *Daily Oklahoman*.
- Sept. 2-4.....Brighton Beach, N. Y., Track Races.
- Sept. 4.....Denver, Col., Track Races, Denver Motor Club.
- Sept. 7-8.....Philadelphia, Track Races, Philadelphia Auto Trade Association.
- Sept. 7-9.....Hamline, Minn., Track Races, Minnesota State Automobile Association.
- Sept. 7-10.....Buffalo, N. Y., Reliability Run, Automobile Club of Buffalo.
- Sept. 9.....Augusta, Me., Hill Climb.
- Sept. 13.....Grand Rapids, Mich., Track Races, Michigan State Auto Association.
- Sept. 15.....Knoxville, Tenn., Track Races, Appalachian Exposition.
- Sept. 16.....Syracuse, N. Y., Track Races, Automobile Club and Dealers.
- Sept. 18-20.....Chicago, Ill., Commercial Reliability Run, Chicago Motor Club.
- Sept. 23.....Detroit, Mich., Track Races, Michigan State Agricultural Society.

- Sept. ....Denver, Col., Track Races, Denver Motor Club.
- Sept. ....Detroit, Mich., Reliability Run, Wolverine Automobile Club.
- Sept. ....Steubenville, O., Hill Climb, Automobile Club of Jefferson County.
- Oct. 3-7.....Danbury, Conn., Track Races, Danbury Agricultural Society.
- Oct. 7.....Philadelphia, Fairmount Park Road Races, Quaker City Motor Club.
- Oct. 9-13.....Chicago, Ill., Thousand-Mile Reliability Run, Chicago Motor Club.
- Oct. 13-14.....Atlanta, Ga., Track Races.
- Oct. 14.....Santa Monica, Cal., Road Races.
- Oct. 15.....New York City, Start of the Annual Glidden Tour, en route for Jacksonville, Fla.
- Oct. 16-18.....Harrisburg, Pa., Reliability Run, Motor Club of Harrisburg.
- Nov. 1.....Waco, Tex., Track Races, Waco Auto Club.
- Nov. 2-4.....Philadelphia, Reliability Run, Quaker City Motor Club.
- Nov. 4-6.....Los Angeles, Phoenix Road Race, Maricopa Auto Club.
- Nov. 9.....Phoenix, Ariz., Track Races, Maricopa Automobile Club.
- Nov. 9, 11, 12.....San Antonio, Tex., Track Races, San Antonio Auto Club.
- Nov. 27.....Savannah, Ga., Vanderbilt Cup Race, Savannah Automobile Club.
- Nov. 30.....Los Angeles, Cal., Track Races, Motordrome.
- Nov. 30.....Savannah, Ga., Grand Prize Race, Savannah Automobile Club.
- Nov. ....Columbia, S. C., Track Races, Automobile Club of Columbia.
- Dec. 25-26.....Los Angeles, Cal., Track Races, Motordrome.
- Date indef.....Port Jefferson, L. I., Hill Climb, Port Jefferson Automobile Club.
- Date indef.....Riverhead, L. I., Road Race, Port Jefferson Automobile Club.

### Foreign Fixtures

- Sept. 2-11.....Roubaix, France, Agricultural Motor Vehicle Show.
- Sept. 9.....Bologna, Italy, Grand Prix of Italy.
- Sept. 10-20.....Hungarian Small-Car Trials.
- Sept. 16.....Russian Touring Car Competition, St. Petersburg to Sebastopol.
- Sept. 17.....Semmering, Austria, Hill Climb.
- Sept. 17.....Start of the Annual Trials Under Auspices of *l'Auto*, France.



Vol. XXV Thursday, August 17, 1911 No. 7

**THE CLASS JOURNAL COMPANY**

H. M. SWETLAND, President  
 A. B. SWETLAND, General Manager  
 231-241 West 39th Street, New York City

**EDITORIAL DEPARTMENT**

THOS. J. FAY, Managing Editor  
 GEORGE M. SCHELL, Associate Editor  
 JAMES R. DOOLITTLE HUGH P. MacCONNELL  
 HANS WEYSZ

**ADVERTISING DEPARTMENT**

W. I. RALPH, 1035 Old South Bldg., Boston  
 C. H. GURNETT, 910 South Michigan  
 L. G. VOGEL, Avenue, Chicago  
 T. B. VAN ALSTYNE, New York and Phila.  
 H. L. SPOHN, New York  
 LOUIS R. SMITH, New York  
 FRANK B. BARNETT, 309 Park  
 Building, Cleveland  
 H. H. GILL, 627 Ford Building,  
 Detroit

Cable Address - - - - - Autoland, New York  
 Long Distance Telephone - - - - - 2046 Bryant, New York

**SUBSCRIPTION RATES**

United States and Mexico - - - - - One Year, \$3.00  
 Other Countries in Postal Union, including Canada - - - - - One Year, 5.00  
 To Subscribers—Do not send money by ordinary mail. Remit by Draft,  
 Post-Office or Express Money Order, or Register your letter.

**FOREIGN SUBSCRIPTION AGENTS**

ENGLAND:—W. H. Smith & Sons, Ltd., 186 Strand, London, W. C., and all book-  
 stalls and agencies in Great Britain; also in Paris at 248 Rue de Rivoli.  
 FRANCE:—L. Baudry de Saunier, offices of "Omnia," 20 Rue Duret, Avenue  
 de la Grande Armee, Paris.  
 GERMANY:—A. Seydel, Mohrenstrasse 9, Berlin.

Entered at New York, N. Y., as second-class matter.  
 The Automobile is a consolidation of The Automobile (monthly) and the Motor  
 Review (weekly), May, 1902, Dealer and Repairman (monthly), October, 1903,  
 and the Automobile Magazine (monthly), July, 1907.

**I**NTELLIGENCE is chained to a stump, as it were, by the man who permits his skepticism to blind his foresight. As an illustration of the devious ways that skeptics arrive at conclusions the following letter will suffice for the purpose: "You continually favor the makers and blame the users of tires. You follow the lead of the tire manufacturers, who advocate a degree of inflation that few cars can stand. I point out also that even the passengers would object to the hardness of the tires that comes from this degree of inflation. In the meantime if the degree of inflation advised by the makers is necessary, why don't you put it up to them to provide tubes that will hold this pressure? I have tires 34 x 4 and am provided with at least 20 tubes that are described as the best makes, but not one of them will sustain under a pressure of 75 pounds per square inch. I find that starting with a pressure as above it is scarcely more than four days before the pressure reduces down as low as 35 pounds. Moreover, I am sure that this pressure does not leak out through the valves. I am informed by one who has every opportunity to know that tires can be made of the type that will scarcely have to be inflated up to the hardness as advocated by you, and my informant also states that a greater mileage may also be expected if the tires are not inflated to such great hardness as you are in the habit of indicating. I believe that you should take this matter up in the interest of users of cars, remembering that the manufacturers of tires advocate a degree of inflation that the tires will not hold, a degree in fact that

few people will use, and from all appearances tire makers skulk behind this inflation situation.

(Signed) "H. W. W."

\* \* \*

**U**GLY as the inference is coming from this reader of THE AUTOMOBILE, it affords an opportunity to point out that the logic of the criticism is defective since, in all fairness, the reader merely accepts the opinion of an individual who claims to have inside information rather than the expressions relative to tire inflation problems as they have appeared in THE AUTOMOBILE from time to time. If our worthy critic will take a piece of wire and bend it back and forth a few times he will doubtless succeed in breaking the wire. If this method of flexing a piece of wire will result in its destruction in a brief space it only remains to observe that flexure in a tire will accomplish the same destruction, but the reason why cotton fabric is employed rather than the wire as above referred to is because cotton is better able to survive the wiles of flexure; but even this excellent material breaks down in time, the measure of which depends upon the quality of the cotton, its weave and amount of flexure.

\* \* \*

**W**HEN an automobilist finds that properly inflated tires produce disagreeable vibrations, especially when a car is traveling at a high rate of speed, it is optional with him to reduce the degree of inflation of the tires in order to promote more agreeable conditions of riding, but the life of the tires will be enormously decreased on account of the ills of flexure, whereas the real remedy lies in properly inflating the tires and for the rest it is a mere matter of regulating the speed of the automobile so that disagreeable vibrations may be avoided. There is room for improvement in the making of tires, and those who have the best interest of the automobile art before them are quite as keen in their advocacy of the production of good tires as there is any occasion for.

\* \* \*

**L**EGISLATION as it relates to the use of the highways by automobilists seems to be of the type that accords with the condition of the automobile art of a decade ago, and it suggests the thought that legislators have failed utterly to keep pace with the growth of this newer industry, which has reached substantially the third place in the leading industries of America, thus bringing into bold relief the glaring inconsistencies of the men whom the States intrust with the framing of the laws relative to the highways and their proper use. The impression is gaining force that some of the legislative methods in vogue are founded upon a type of stupidity that will lead to disaster. Take the State of New Jersey as an illustration. Its citizens freely admit that automobilists generally are among the most intelligent of the nation's makeup. But in the face of this fact the legislative forces in the State of New Jersey have built a wall around that State depriving these intelligent citizens of the right to traverse its highways excepting under conditions that would affront the intelligence of a skate. It is a mere matter of time, of course, when the citizens of New Jersey will awaken to the fact that they are being put to great loss, but it will take a number of years for the State to regain what it is losing through its failure to encourage the principles of reciprocity.

# M. C. A. Clears Sporting Skies

## Bans Half-Mile Tracks and Sifts Rules

*Half-mile dirt track racing was killed; mile track owners were ordered to take precautionary measures to insure safety and supervision of such racing was provided; weight restrictions in stock car race was limited; weight restrictions in stock car classes were raised and truck contest sanctions were restricted to regularly organized automobile clubs by the recommendations of the M. C. A. in its meeting at Detroit last week. Many more legislative changes were considered and discussed.*

**D**ETROIT, Aug. 14—A number of radical changes in the rules governing automobile racing were discussed and recommended to the Manufacturers' Contest Association by the executive committee of that body which met here Thursday and Friday. The most prominent of the recommendations are as follows:

Refusal of all sanctions for racing on half-mile dirt tracks.

Mile-track associations to be given sanctions only after safety has been approved by a member of the Contest Board.

The number of starters in any race to be limited to one for every 400 feet of track.

The elimination of the weight restriction in stock car races and the limiting of such events to such cities only as offer a market which may be influenced by the results of the events.

Refusal of truck contest sanctions to any but regularly organized automobile clubs.

In addition a committee was appointed to wait upon the N. A. A. M. at its next meeting, for the purpose of securing from that body financial backing which will enable a more thorough supervision of the sport. Ways and means to this end were discussed though not formally voted upon. Some of the members of the committee were in favor of placing the Contest Board in the position of race promoter while others believed that close supervision of the work of the promoters and the presence of an authorized representative of the Board would be sufficient.

President Howard Marmon of Indianapolis presided over the sessions of the committee which were attended by 15 members, as well as Chairman Butler of the A. A. A. Contest Board, David Beecroft and F. E. Edwards of the technical committee of that body, and George Robertson, president of the Racing Drivers' Association.

It was the unanimous sentiment of the committee that racing on dirt half-mile tracks should be abolished. The committee would also have made a similar recommendation regarding the mile tracks, but for the fact that this would deprive many cities of the sport altogether. Its recommendation in this respect is for a rigid examination of all such tracks before sanctions are granted. Specific recommendations are that the tracks shall be oiled several days before the meeting and that the inner rails shall be lowered to such an extent as not to interfere with the safety of the drivers whose cars shall happen to be diverted to the infield of the course. This was done on the advice of George Robertson, who advanced the theory that a large share of injuries from such accidents were the results of the height of the top boards of such fences. To further insure the carrying out of such safeguards it was recommended that every promoter give bond for \$500 that precautions will be taken.

The elimination of the weight restrictions on stock car races was a general surprise, the significance of which is not readily

apparent. It was rumored, however, that several companies which were very anxious to have this done, stood ready to not only take an active share in racing but also to lend financial assistance to the Contest Board in its endeavor to secure a firm footing and to guarantee the presence of at least one of its members at every race meeting.

The recommendation regarding the elimination of sanctions to corporations and individuals other than automobile clubs was made to prevent the securing of gratis advertising by such promoters. While truck and delivery wagon contests were particularly mentioned in this connection, the recommendation applies to all sorts of competitions between motor cars.

All the recommendations will be presented to the parent association at its meeting in New York, September 6.

The first topic to be taken up was that of the proposed Glidden tour for October which is scheduled to run from New York to Jacksonville, Fla., by way of Atlanta, Ga. This tour is scheduled to be a good roads booster scheme and as such, Chairman S. M. Butler, of the Contest Board, asked that the entering of cars by private owners be simplified by not requiring said cars to be registered. At present it is necessary that stock cars be registered with the contest board before they can compete in any reliability run. There are a few manufacturers who have refused to register their cars this year. They have refused to register them in order keep their dealers and owners from entering contests. Chairman Butler explained that there are many owners of these unregistered cars who wish to enter this southern Glidden, and it was for the benefit of these that the demand to eliminate the stock registration clause was introduced. After continuous discussion it was decided to make no change in the rules so that only registered stock cars will be allowed to compete. Representatives of some makers present frankly admitted that they did not want owners to enter contests and had refrained from having their cars registered in order to prohibit owners entering such.

It was the general consensus of opinion that no change should be made in the present stock car rules. It was a matter of general regret that stock car competition has not been entered into with greater vim by the manufacturers this year. The Elgin races will be practically the only large stock car events of the season. It was resolved that for the 1912 season a contest committee be asked to sanction twelve stock car events in which its technical committee will attend. These events are to be scattered through the greatest market sections of the country.

It was the unanimous opinion of the many delegates that additional precautions be taken in the matter of roadway, beach and track races. It was accordingly recognized that in all speed contests a mechanic must ride with the driver. This also applies to practice for road races or track meets.

Among those representatives attending the meeting were: Howard Coffin, Hudson Motor Car Co.; Howard Marmon, Nordyke & Marmon Co.; S. M. Butler, Chairman Contest Board A. A. A.; F. E. Edwards, Chairman Technical Committee A. A. A.; C. E. Emise, Lozier Motor Car Co.; M. C. Meigs, J. I. Case Threshing Machine Co.; N. A. Hawkins, Ford Motor Car Co.; J. H. Newmark, Oakland Motor Car Co.; Mortimer Reeves, United States Motors Co.; A. W. Markham, Mais Motor Truck Co.; E. W. Curtis, Electric Vehicle Association of America; Elmer Pratt, Pierce-Arrow Motor Car Co.; George H. Robertson, President Racing Drivers' Association, and Russell Field, secretary, Manufacturers' Contest Association.

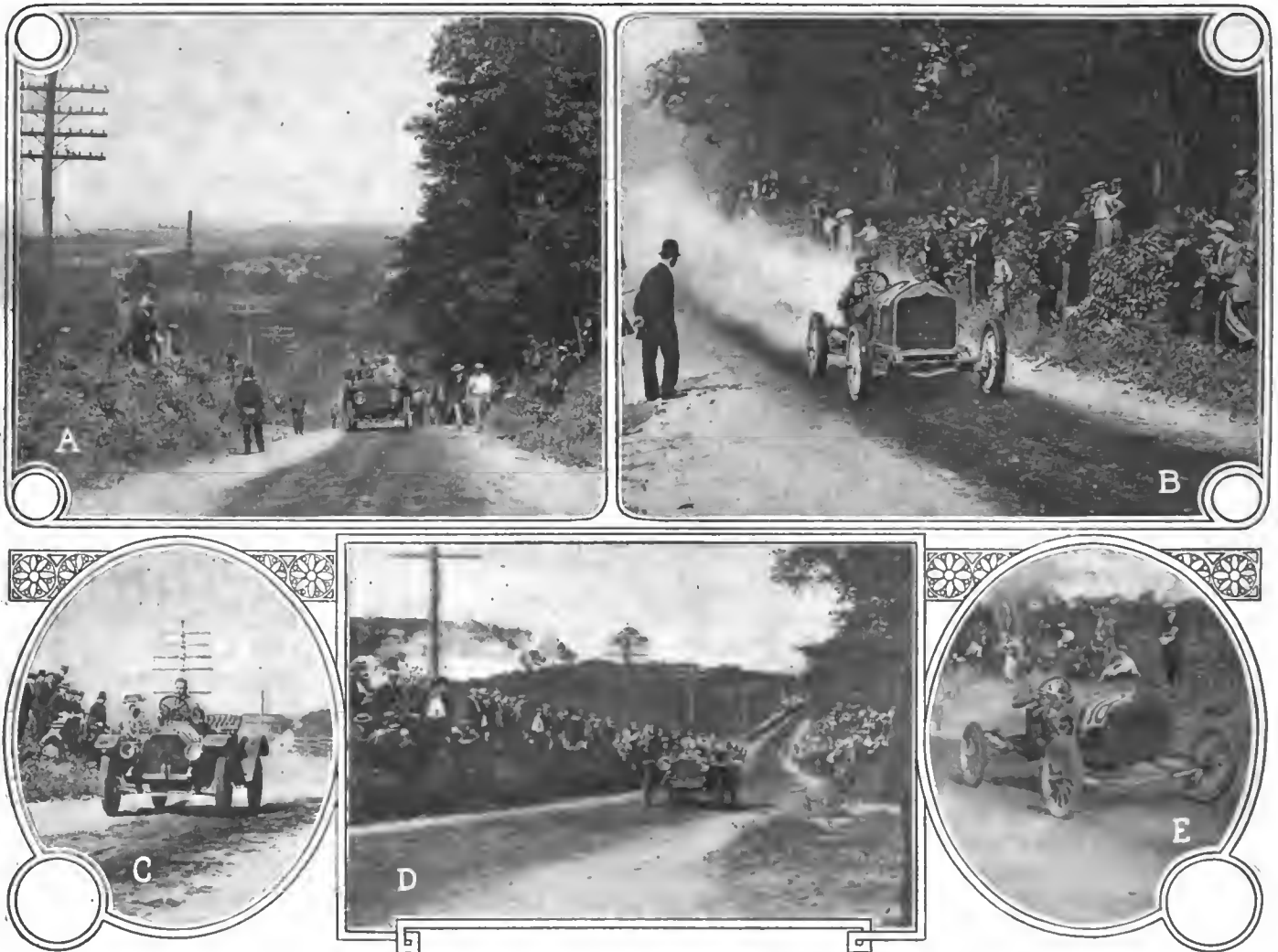

A—View from the top of Dead Horse Hill, showing one of the stiff grades to be negotiated B—National, No. 2, Wilcox, driver, which captured four races and lowered the record for gasoline cars  
 C—Oakland, No. 15, Bauer, driver, winner of the \$801-\$1200 stock class D—Velie, No. 9, Wiggins, driver, winning the 4A race for \$1601-\$2000 stock cars E—Flanders, No. 18, Witt, driver, which landed the 1B class race

## Success Crowns Dead Horse Climb

### Biggest Eastern Event of Season Is Held

Thirty-four cars, representing the stock models of sixteen makes of American automobiles contested for hill-climbing honors at the sixth annual renewal of the Dead Horse Hill Climb under the auspices of the Worcester Automobile Club, Saturday. The cars representing the National, Cole, and Oakland factories won every event in which they were entered and a special National won four races, and in addition thrice lowered the record of the hill for gasoline cars. There were eighteen races decided.

**W**ORCESTER, MASS., August 14—Dead Horse Hill was mounted sixty-one times during the sixth annual hill-climbing contest under the auspices of the Worcester Automobile Club on Saturday afternoon.

Records were lowered all around and a new mark for gasoline cars on the course was set. The three-year-old record of the hill, made by a Stanley steam car (Baldwin) at 54 seconds

flat was not quite reached. A four-cylinder National with the regular stock diameter of cylinder but with a stroke elongated to 7 1-2 inches and rated at 50-horsepower swept the boards in the free-for-all classes. Four times this car started with a factory driver at the wheel and four times the officials announced that it had won. Each of these events developed the hottest sort of a contest, for the big brown Knox car that made such a creditable showing at Indianapolis on the occasion of the late 500-mile international sweepstakes, pushed out the blue car to its speed limit and in the final event for the hill record, came within a second of defeating the National.

The Stanleys which were entered in the big car events did not equal the work of the former season when they made the speed record.

The contest was far and away the most important in a sporting sense that has been held in the East this season so far, and far exceeded any of the former climbs that have been held on Dead Horse Hill.



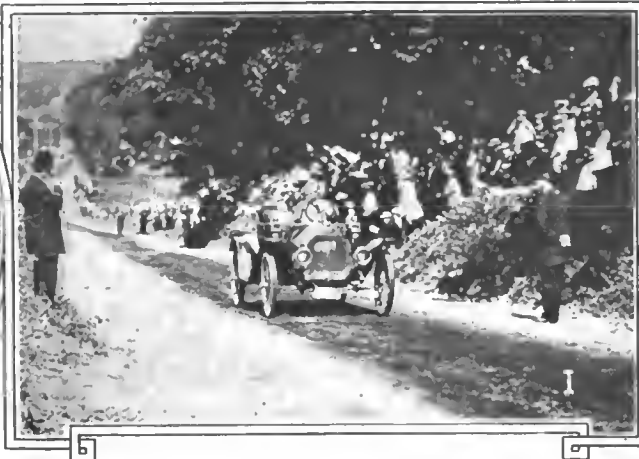

G—Cole. Jenkins, driver, which won two races in fast time in stock and non-stock classes

F—Showing how the spectators massed on the natural grandstand formed by the side of the hill

J—Buick, No. 13, which won the 161-230 cubic inch class race

I—Krit, No. 24, Pilling, driver, winner of the 1A race—\$800-and-under class

H—The Gramm five-ton truck negotiated the hill with a full load

There were thirty-two starters in the various events not reckoning ten motorcycles which competed for two prizes. One of these, an Indian number 34, ridden by Frank Hart, lowered the record of the hill for this type of vehicle by making the climb in 34.60 seconds.

There was a tremendous crowd out to see the races and the club handled it in such a way that it probably made a handsome profit out of the affair. The lower end of the course was boarded in and admission to the side hills was charged. Of course everybody who saw the contests did not pay, but a fine percentage of them had to. Then, too, the prizes in the various classes consisted largely of certificates issued by the club showing the performance of the cars.

A more perfect day for the climb could hardly have been made to order. It was warm when the sun shone but the sky was partly overcast and the temperature delightful. The course was not smooth and despite its preparation for the climb was dusty. The running of the numerous trials was done accurately and promptly and the whole affair reflects much credit upon the club.

Sure enough stock cars competed in their various classes and gave a comparative exhibition of their prowess and powers in competition with similar cars which is expected to do much toward stimulating business. Every entry in Classes A and B which include respectively, equipped automobiles according to price classification, and stripped stock chassis, were examined and checked over by A. F. Camacho as technical representative of the Contest Board. On Friday night Mr. Camacho was in-

formed that there might be a protest lodged against the Cole pair entered in their stock chassis class and he pulled down the cars, measuring the cylinders and other questioned parts. No difference was discovered between the cars entered and the certified stock models and they were allowed to start. There was also some question raised as to the eligibility of two of the Buicks entered, but it was shown that neither of the cars was a model of the current year and the protest was squelched in its incipency. All the other cars in Classes A and B were not questioned, but checked up with the certificates.

The timing was done with an electrical instrument, the property of the Worcester Polytechnic Institute and was supervised by Professor David L. Gallup and a corps of assistants from the college. The instrument wrote the record of each climb in an unmistakable way and while the seconds were only divided into twentieths in the announced figures, the hundredths or even more minute decimal fractions could be determined by using a magnifying glass on the tape, if such a course proved necessary in order to differentiate a winner in case of a very close finish. This occasion did not arise during the afternoon.

The first number on the program was for stock cars selling for \$800 and less and the only entry to qualify was a Krit. The next larger class was won by an Oakland runabout which defeated a Cameron. The class selling from \$1,201 to \$1,600 was captured by a bigger Oakland from a New Parry. In the 4A event for cars selling as high as \$2,000, Velie number 9 won handily from a Buick (38) and another Velie, while 5A went to a National (40) entered by the Poertner company of New

York and driven by Rutherford. Another National stock car and a Knox (4) finished close up.

In the stripped chassis classes, the smallest class open to cars of less than 160 cubic inches piston displacement was won by a Flanders 20 in the astonishingly fast time of 1:18.85. An Empire was second. Hudson 16, a 20-horsepower car had a walk-over in the 161-230 cubic inches class and the 231-300 class race was won by Cole 22 in 1:17.55, with Firestone-Columbus second and another Cole in third place.

Class 4B for cars of 301-450 cubic inches developed one of the prettiest struggles of the day and attracted a field of eight fast cars. The winner turned up in National 1 (Wilcox) who mounted the three hills in 1:00.35, lowering the record for this class. The same may also be said for the foregoing performances of the Flanders in 1B and the Cole in 3B. National 5 was a fair second and National 3 a close third. Another National, a Velie, Knox and two Buicks also ran.

Class 5B for cars from 451 to 600 cubic inches piston displacement was won by Knox 6 (Coffey) in 1:03.60.

In the non-stock sections in which most of the competing cars were in reality stock cars, the showing was also excellent. In Class 2C which corresponds with 2B except for weight restriction, Buick (10) had a walkover.

In Class 3C for cars of 231-300 inches displacement, the Cole pair finished first and second, the winner, number 22 turning the trick in 1:16.75. The third place was taken by the Cameron Six.

Class 4C brought out a field of six including three Nationals, a Knox and two Buicks. The finish was in that order, the winner, number 1 National (Wilcox), making the run in 1:01.70.

The 5C class for big cars saw the hill-record for gasoline cars lowered a peg and later in the afternoon it was twice brought down from the new level. National 2, a 50-horse-power machine and said to be a duplicate of the cars that raced at Indianapolis on Decoration Day and of the car that cleaned the boards at the Galveston beach meeting this month, won first honors in 55.70 seconds, over two seconds faster than was made by a Fiat (90) (Bragg), last year over the same course. At that, the car did not get a really good start and did not make the first quarter of the hill at top speed. The Indianapolis Knox almost equalled the time of the Fiat and was credited with 58.80 seconds. Another Knox was third.

Then came the free-for-all events. The first of these was for any kind of an automobile and National 2 (Wilcox) made the ascent in 0:55.50, again lowering the record of the hill. The big Knox was second, two seconds slower and a Stanley Steamer was third, nine seconds after the Knox.

The second race in this class was for the Amateur Championship of Worcester County. The trophy for this race had already been won twice by a Stanley steamer guided by Jay Clark, Jr., and Mr. Clark foreclosed his option on the cup by driving his car leisurely up the hill in 1:15.75 for a walkover victory.



K—Worcester's bluecoats marching up the hill to their stations

The third race was for D class gasoline cars and National 2 again triumphed over the Knox pair.

The final event which was open to anything in the automobile line, for the record of the hill, witnessed another slash at the new mark when National 2 clipped 1-20 of a second from its recently established mark and set the new target for aspiring hill climbers at 55.45 seconds. The big Knox was within a second of the winner's time.

The hill record would have been materially lowered in this event except for an unfortunate occurrence near the finishing line. Wilcox at the wheel of the big car got away to a magnificent start, taking the little bridge just beyond the trip wire with his throttle wide open. Up the first grade, a stiff climb averaging rather more than 8 degrees and infinitely stiffer than the figures apparently show, the car plunged, making a new mark for the quarter distance. Along the little flat bench of perhaps 100 feet the car shot with dazzling speed and entered the 12 degree hill on high gear with the driver's foot hard on the accelerator. The fierce energy of the motor raised clouds of dust under the traction wheels and like a bird the big car mounted the grade that numbers its slain horses by the hundreds. At the top there is another little bench and then a sharp, long grade, the heaviest spot in which is over 20 degrees. Across this flat and charging at the foot of the hill the car began its upward flight to the wire at a terrific rate of speed.

Everybody at the crest of the hill and around the timing apparatus station was tensely awaiting the flash of the monster automobile when a touring car slipping out of its parking space just at the brow of the hill came dashing along toward the wire. The car reached the wire just as Wilcox began to mount the third hill and tripped the machine as the National's exhaust gave warning of its approach under full power. An assistant of Professor Gallup seized the wire and slipped it over its hook again a fraction of a second before the front wheels of the racer struck the



L—General view at the foot of Dead Horse Hill, where the contestants lined up

wire. The National probably lost two full seconds between the crest of the hill and the wire on account of its proximity to the touring car as Wilcox took his foot from the accelerator and even closed his throttle in order to avoid a rear-end collision with the intruder. He did not apply his brakes and by some quick-witted driving missed a bad mess with the other automobile. Except for this happening there was nothing disagreeable about the afternoon's sport, but the car was surely robbed of the honor of establishing a mark lower than that of the Stanley Steamer.

Knox No. 7, the big car driven by Belcher also lowered the last year mark of the Fiat, in this event turning the course in 56.30 seconds. This is 85-100 of a second slower than the winner, but 1.70 seconds faster than the Fiat's time.

The policing arrangements for the event were not of the highest class, as the number of men detailed proved insufficient to handle the crowd, and along toward the end of the card when the big cars were contesting the course was not clear at all times.

One thing that aggravated this condition was the injection of the truck exhibitions between the races. First a Cameron delivery car went up in 2:00.05 and then a fully loaded Gramm truck of five tons capacity made the climb. This car covered the course in 6:25.25 and when it passed many of the spectators thought the last race was finished and swarmed out upon the course. As the big cars were slated to try for the record of the hill after the trucks had passed, the situation was acute for a few minutes. Fortunately there was no accident except that which deprived the National of the absolute record for all classes of automobiles. The summary:

1-A—Stock Cars for \$800 and Under			
No.	Car.	Driver.	Time
24	Krit	Pilling	2:10
2-A—Stock Cars Selling at \$801 to \$1,200			
15	Oakland	Bauer	1:50.15
21	Cameron	White	3:57.55



View from the grandstand at the automobile beach carnival at Long Branch

3-A—Stock Cars Selling at \$1,201 to \$1,600			
14	Oakland	Bauer	1:37.10
26	New Parry	Wiggin	1:47.85
4-A—Stock Cars Selling at \$1,601 to \$2,000			
9	Velie	Wiggins	1:21.15
12	Buick	Jessup	1:36.60
10	Velie	Wallace	1:48.95
5-A—Stock Cars Selling at \$2,001 to \$6,000			
5	National	Rutherford	1:04.30
8	Knox (4)	Coffey	1:08.15
4	National	Pugh	1:11
1-B—Stock Chassis Under 160 Cubic Inches, Minimum Weight 900 Pounds			
18	Flanders	Witt	1:18.85
17	Empire	Kaesser	1:55.10
2-B—Stock Chassis 161-230 Cubic Inches, Minimum Weight 1,200 Pounds			
16	Hudson (20)	Johnson	1:47.50
3-B—Stock Chassis 231-300 Cubic Inches, Minimum Weight 1,500 Pounds			
22	Cole	Jenkins	1:17.55
25	Firestone-Cols	Peard	1:24.25
23	Cole	Habich	1:29.60
4-B—Stock Chassis 301-450 Cubic Inches, Minimum Weight 1,800 Pounds			
1	National	Wilcox	1:00.35
5	National	Rutherford	1:03.45
3	National	Randall	1:05.45
8	Knox (4)	Belcher	1:05.80
11	Buick	Jessup	1:09.25
4	National	Pugh	1:12.70
9	Velie	Cole	1:14.75
10	Buick	Wallace	1:15.70
5-B—Stock Chassis 451-600 Cubic Inches, Minimum Weight 2,100 Pounds			
6	Knox	Coffey	1:03.60
2-C—for 161-230 Cubic Inches, Cars No Weight Restrictions			
13	Buick (10)	Hooker	1:29.40
3-C—for 231-300 Cubic Inches, Cars No Weight Restrictions			
22	Cole	Jenkins	1:16.75
23	Cole	Habich	1:20.95
19	Cameron (6)	White	1:43.20
4-C—for 301-450 Cubic Inches, Cars No Weight Restrictions			
1	National	Wilcox	1:01.70
3	National	Randall	1:02.80
5	National	Rutherford	1:03.35
8	Knox (4)	Coffey	1:06.85
11	Buick	Jessup	1:14.20
10	Buick	Wallace	1:17.95



A portion of the big crowd which witnessed the events at the Long Branch carnival

5-C—for 451-600 Cubic Inches, Cars No Weight Restrictions			
2	National (50)	Wilcox	55.70
7	Knox (6)	Belcher	58.80
6	Knox (6)	Coffey	1:07.15
1-D—Free-for-All			
2	National (50)	Wilcox	55.50
7	Knox (6)	Belcher	57.65
27	Stanley Steam	Walsh	1:06.85
2-D—Worcester County Amateur Championship			
29	Stanley Steam	Clark	1:15.75
3-D—Free-for-All Gasoline Only			
2	National (50)	Wilcox	55.70
7	Knox (6)	Belcher	56.90
6	Knox (6)	Coffey	1:06.70
4-D—Free-for-All Record of the Hill			
2	National (50)	Wilcox	55.45
7	Knox (6)	Belcher	56.30
28	Stanley Steamer	Clark	1:02.40
6	Knox	Coffey	1:03.20

## Long Branch Parades

Decorated automobiles paraded Saturday at Long Branch as the culminating feature of the midsummer carnival conducted annually at that resort. Automobiles were used to a much greater extent this year in the festival than ever before in the history of the institution.

LONG BRANCH, N. J., Aug. 14—An automobile parade was one of the big features of the closing day of the third annual midsummer carnival held here under the auspices of the Long Branch Board of Trade, on Saturday. Automobiles were used in the festivities to a much greater extent this year than ever before and proved to be a prime factor in each succeeding stage of the program.

During the boardwalk exercises, hundreds of cars were used to convey sightseers and when the baby parade was in progress, the procession of pretty children and their prettier mammas and nurses was reviewed from the vantage ground afforded by the parked cars.

Saturday afternoon was the culminating point in the festival and the parade of automobiles, some of them fearfully and wonderfully decorated, was the big number of the program.

At the conclusion of the parade the judges announced that the first prize for the best decorated private automobile had been awarded to Mrs. John H. Parker. The prize for original design was won by M. G. Kahn, Gimbel Brothers, Park and Tilford, Leo Metzger and Adolph Graf were other winners in the competition.

## Remy Brassard Successfully Defended

BALTIMORE, Aug. 14—The Remy grand prize and brassard were successfully defended by Benz (Burman) at Electric Park Saturday on the half-mile track. The other races were won by Kline (2), Abbott-Detroit (1) and Mercedes (1).

## Seven Still Perfect In Chicago Truck Run

**K**ALAMAZOO, MICH., Aug. 15—After eight day's running the Chicago *American's* commercial vehicle reliability test from Chicago to Detroit and return there are only seven of the twenty-five starters left with perfect scores. The survivors to date are the No. 6, Hewitt; 23, Lemoon; 32, Federal; 16, Kelly; 13, Mais, and Nos. 10 and 11, Buick. The three Gramms have not been figured up as yet on to-day's run, but they have been out of the perfect score class for several days. The past week has seen some remarkable work on the part of the contesting cars. The second day's run was from South Bend to Fort Wayne, and at the end of the trip there were sixteen still perfect. There were three penalized on the run from Fort Wayne to Toledo on Thursday, five were penalized going to Lima on Friday, while Detroit was the destination on Saturday, a stop being made there over Sunday. The run from Detroit to Jackson on Monday was comparatively easy, with only one penalization. To-day, however, the run from this city resulted in seven penalizations. So far there has been only one withdrawal, the No. 9 Poss being withdrawn the end of the third day, a cracked cylinder jacket being the main difficulty. As the score stood to-night it was as follows: No. 9, Poss, out; No. 24, Lincoln, 4 points; No. 37, Vandike, 13; No. 6, Hewitt, perfect; No. 20, Bauter Jurgens, 7; No. 30, Owosso, 22; No. 38, Clark, 68; No. 39, Ideal, 7; No. 34, Chase, 4; No. 1, Gramm, 1492; No. 23, Lemoon, perfect; No. 38, Stephenson, 62; No. 32, Federal, perfect; No. 2, Gramm, not figured; No. 16, Kelly, perfect; No. 13, Mais, perfect; No. 3, Gramm, not figured; No. 14, Dayton, 30; No. 17, Kelly, 3; No. 4, Gramm, not figured; No. 10, Buick, perfect; No. 11, Buick, perfect; No. 27, Kretworth, 21; No. 31, Chicago Pneumatic, 26; No. 33, Chase, 6; No. 5, Modern, 26.

### Four Road Races at Cincinnati

CINCINNATI, Aug. 14—The course selected for the Fern Bank dam road races is 7 7-10 miles in length with Cooper avenue, Blue Ash road, Montgomery Pike and Reading road making the four sides of a quadrangle. The committee has contracted for the erection of a grand stand located 12 miles from the city on Blue Ash road to seat 20,000.

The Interurban company will give the use of its car barns and machine shops at Silverton in near proximity to the course for two weeks prior to the races, insuring comfortable quarters and all necessary conveniences for repair work. The numerous crossings are to be well guarded and car service to and from the points of view will be ample.

The most valuable prize announced thus far is by The Cincinnati Automobile Club; it will be of not less than \$1,000. Four races, 125, 150, 180 and 250 miles, will be run.



Where the entrants in the Chicago truck were parked overnight in Lima, Ohio

### Columbus to See 200-Mile Race

COLUMBUS, O., Aug. 14—Arrangements have been completed by the Columbus Automobile Club, of Columbus, Ohio, for a 200-mile sweepstake race to be run on the Columbus Driving Park track September 3. At first the club was figuring on a number of different events for its 1911 race meeting, but after consideration it was decided to have the 200-mile contest. The contest will be a sweepstake with a purse of \$1,000 to the winners in addition to \$1,500 in trophies.

The race will be limited to cars having 600 or less cubic inches and the drivers who participate must reside in the State of Ohio. A sanction has been secured from the Contest Board and the representative is Mr. Grimes, of Cleveland. It is the purpose to make the meet a popular affair and an admission fee of only 50 cents will be charged. It is expected that at least 25 cars will start in the big race.

At the Contest Board the information was given that the Columbus sanction would be granted providing the track was adequately protected according to the rules.

### Premier Caravan Finishes Tour

LOS ANGELES, CAL., Aug. 14—Still intact, the Premier caravan consisting of ten touring cars and two official automobiles rolled into Los Angeles last week and completed its long journey from Atlantic City, N. J. The ceremonies were finished when the front wheels of the dozen cars were driven into the Pacific ocean.



Scene in Cadillac Square, Detroit, where the Chicago truck run stopped overnight

The whole trip has been accomplished, according to those who took part in it, without resorting to anything but the power of their own motors. The schedule arranged for the tour was something in excess of 150 miles a day and the start and finish were on schedule time.

### St. Louis Tour Starts West

St. LOUIS, Aug. 14—Thirteen contestants, three official cars and one non-contestant left St. Louis early Monday morning on the Manufacturers' and Dealers' Reliability Run to Kansas City. At the time of the start it was said in St. Louis that the Kansas City motorists who had been announced to make the return trip with the St. Louisans had abandoned the plan, and the contest will be entirely a local affair. The tourists expected to arrive at Moberly Monday night, by way of Mexico and Columbia. The cars taking part are: Interstate, Dorris, Mitchell, Marmon, Ford, Ford, Ohio, Buick, Cadillac, New Parry, Flanders, Flanders, Hudson, American Traveler, Amplex, Marion and Ford.

The cars were given a rousing send off despite the smallness of the procession and at every town along the route delegations of automobile enthusiasts met the tourists and escorted them through town. Good weather was encountered and the roads were fair.



## Mont-Ventoux Hill Climb

The annual French automobile classic which is held on Mont-Ventoux was a greater success this year than on any previous occasion. Several of the cars that had taken part in the recent light-car race vied with each other for fresh honors.

**B**EDOIN, Aug. 6—The hill which starts from here is an ideal one for a race, as it is possible from the plateau at the top to witness the cars making the arduous climb practically for the whole length of their course. Although the record for the hill was not beaten, nevertheless the time made by Deydier on the Cottin-Desgouttes was very fast. This car took part in the Grand Prix de France and it is to be regretted that the driver did not have more opportunity to study the hill as some precious time was lost on several of the turns. The Ford car, shown in the illustration, having been put in order after its accident at Le Mans, finished first in its class and second in the general classification, finishing slightly under three minutes slower than the winner. The Lion-Peugeot cars driven by the veteran pilots Goux and Boillot finished first, each in their respective classes. Gaste driving a Rossel car, who won most of the races held in the South of France last year, including the Salon meet, was unable to make good time owing to the lightness of the rear portion of the car; oftentimes the wheels spun round while the car remained stationary. The Bugatti despite a broken front spring and a burst tire managed to climb the



The winner of the Mont-Ventoux hill climb, a Cottin-Desgouttes, driven by Deydier

hill in 30 minutes, 55 seconds. The meeting was organized by the Automobile-Club Vaclusien and the arrangements were carried out without a hitch. The following are the list and times of the winning cars.

Car.	Driver.	Time.
	Sixth Class (2)	
Rosael	Gaste	23 m 34 s
	Sixth Class (1)	
Cottin-Desgouttes	Deydier	19 m 45% s
	Fourth Class	
Ford	Depasse	22 m 19% s
	Third Class	
Lion Peugeot	Boillot	23 m 30% s
Aquila Italiana	Narzaglia	28 m 17 s
Lancia	Tangazzi	30 m 21 s
Pilain	Fournier	30 m 38 s
	Second Class (2)	
Bugatti	De Vizcays	30 m 55 s
	Second Class (1)	
Lion Peugeot	Goux	25 m 3% s

## Lebanon Road Temporarily Closed

Owing to new road construction under way on the east side of Lebanon mountain, on the main route between Albany and Pittsfield, the Massachusetts Highway Commission has decided to close the road for several weeks.

## State Officials to Inspect Roads

One of the most important conferences in the interest of highway improvement that has ever taken place in the East, will be held within the next fortnight, when the highway officials of New York, Massachusetts and Connecticut will make a tour of inspection over some of the more important roads of their respective States.

The details for this conference are now being arranged by the Touring Club of America. The New York delegation will meet at Albany and from that point the motor tour will be made to Pittsfield and thence to Springfield, Mass., where the general conference will be held.

## Hupp Sells Stock in Motor Company

**DETROIT, MICH., Aug. 15**—Robert C. Hupp, president of the Hupp Motor Car Company, of which he was also organizer, yesterday disposed of his stock to a number of the present officers of the company and will on September 1, cease all connections with it.

Until that date he will retain his offices of president and general manager, although practically all of his time will be devoted to the affairs of the Hupp Corporation, a collection of manufacturing plants in Fairview east of Detroit.

Mr. Hupp's retirement from the affairs of the Motor Car Company has been rumored for some time but has been categorically denied by both himself and by the officers of the company.

Local gossip is now busy with the future plans of the Hupp Corporation. It is freely rumored that it will soon add to its products a gasoline car of light type, on lines somewhat similar to those of the Hupmobile. Mr. Hupp refuses to discuss this matter aside from authorizing the statement that the Hupp Corporation is now fully equipped to build any sort of automobile product. Prior to his organization of the Hupp Motor Car Company, which has been a marked financial success, Mr. Hupp was connected with the Oldsmobile Company, both at Detroit and Lansing.

## Briscoe Predicts 210,000 Cars for 1912

Benjamin Briscoe, president of the United States Motor Company, has declared in an authorized interview that the production of passenger automobiles in 1912 will in his opinion reach the record-breaking total of 210,000 cars. He states that he believes that fully 60 per cent. of this number, or 126,000, will be required to fill the demands of physicians, contractors, salesmen, etc., who use their automobiles in business and pleasure.

Mr. Briscoe estimates that the average cost will be reduced from \$1,533, where it stood last year, to about \$1,100. This would indicate a largely increased production of cars selling under \$1,000. In his figures Mr. Briscoe does not include trucks.



Depasse rounding the hairpin bend in a Ford car in the Mont-Ventoux hill climb



# Oklahoma City Shows the Way

## Cow Town Is Building Vast Park Speedway

*America's newest metropolis, Oklahoma City, is completing a speedway boulevard project that makes anything else of its kind in the world look like a counterfeit. The course is almost finished and when the last touch has been added the course will be twenty-six miles long, surrounding the city with a ninety-foot speedway without a single grade crossing, smooth as to surface and absolutely protected throughout its length. Already plans are being made to run off some of the motor classics on the new course before cold weather sets in.*



Side view of one of the arches over a "fill"

from all parts of the country, because of the excellent opportunities offered on the course for smashing records.

### O K L A H O M A C I T Y, O K L A.,

Aug. 14—Oklahoma City is spending a half million dollars in constructing an automobile boulevard, approximately 26 miles in length, and a system of public parks. Plans are being discussed by the local and State automobile associations for holding races which will attract the attention of the speed demons

The route of the boulevard circles the city in a rectangular manner, 6 miles to the side, with half-mile curves at the corners. The heaviest grade is approximately 3 per cent. for a distance of a little more than 900 feet. All grade crossings have been eliminated by subways and the ravines through the parks are bridged with concrete arches.

The speedway proper is 90 feet wide. On either side are driveways for carriages. At different places these cross and recross to opposite sides of the track by subways. At no place do they cross a grade, thus eliminating the possibility of the fatalities of road races.

Twenty-one miles of the main drive have been completed, so far as grading, construction of bridges and elimination of sharp curves are concerned. The remaining portion of the track is being held up pending adjustment of little details as to the right-of-way through a school-land section. The dust is to be laid and packed with oil.

When completed the track is expected to be one of the fastest and least dangerous of the inland race courses, combining the possibilities of the straightaway and the road race course with sharp curves, steep grades and grade crossings eliminated.

Constructed under the supervision of the city park commission, the boulevard is being built with all consideration for the development and bringing out of nature's beauty spots along the route. Four large park tracts have been acquired at the northeast, northwest, southeast and southwest corners of the boulevard system, consisting of approximately 1,600 acres. A lake of 60 acres has been created at the northeast park. A second of 70 acres is to be built at the southeast corner. Property owners at various points have donated smaller tracts for park purposes at various times until the city now has more than twenty-five parks with a total estimated value of more than \$1,750,000, obtained at a total cost of \$209,319.17.

A preliminary bond issue of \$400,000 was voted in 1909 to



View of the 26-mile automobile speedway at Oklahoma City. All grade crossings have been eliminated and one 3 per cent. incline is the steepest

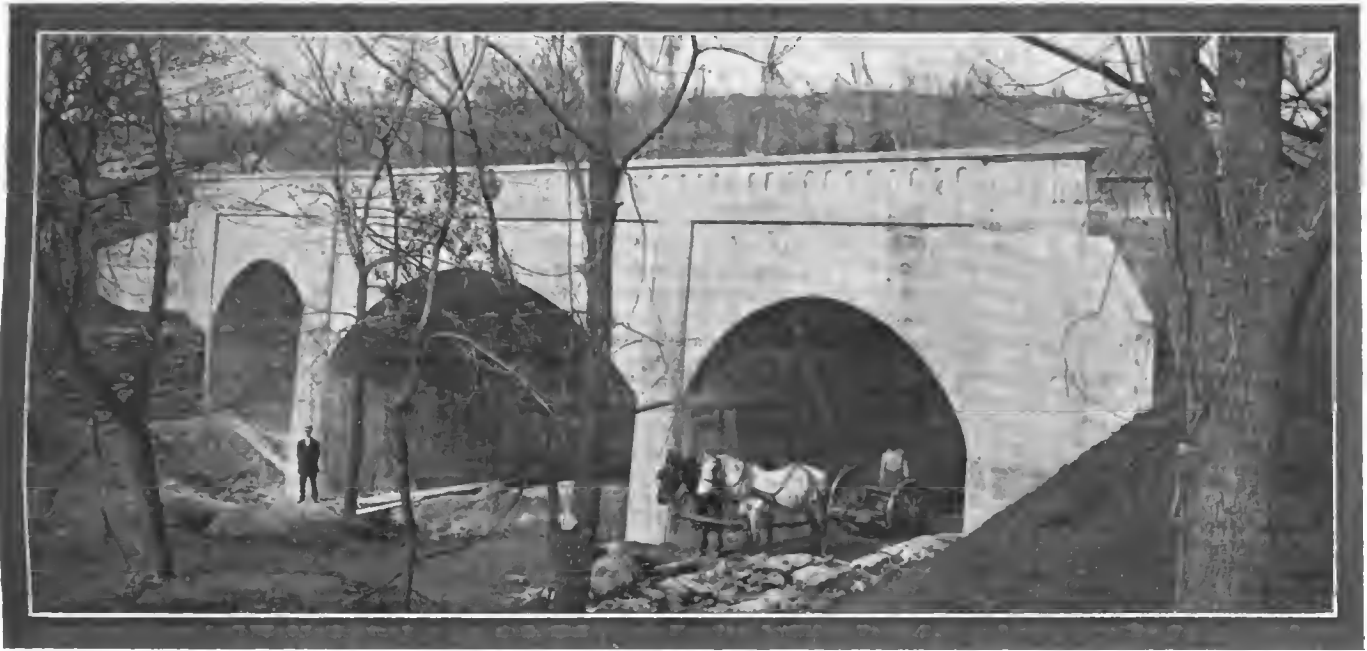

Triple-arched bridges span the streams and form subways for carriage driveways at the right and left

begin the work. Property adjacent to parks, valued at \$500,000, is now held by the commission, and is ready for the real estate market, all of which was obtained by donations and financing by the board in the purchase of the property for the right-of-way. The value of the land obtained as a side issue to the proposition has more than paid for the first series of bonds.

One of the most beautiful parts of the course is the portion passing through the northeast park. It passes over the dam in a roadway 40 feet wide. The dam is 1,100 feet long and 44 feet high. The spillway is 40 feet wide, covered by a reinforced concrete arch. The driveway is 60 feet wide between the balustrades, accommodating both the auto course and one carriage driveway.

On the north line is an unique structure consisting of a 5-foot culvert over which is constructed a 20-foot bridge or subway, the design being intended to allow the ordinary drainage to pass through the culvert and the heavy floods to flow through the 20-foot bridge. The bridge also serves as a connecting driveway between the two carriageways under the auto course. Just east of this combination bridge and culvert is another curious bit of construction work. The speedway passes over a deep ravine, just above a rocky waterfall. A concrete slab was constructed from one bank to another so that there is apparently no bridge. On one side is the effect of a shallow valley and a 50-foot ravine on the other.

The greatest opposition met by the commission in obtaining the right-of-way was from school-land lessees. They opposed the boulevard, giving as their reason that it would enhance the value of the land very materially, thus causing them to pay more for it when it is placed on the market. Appeal was made to the Legislature for relief and it responded by authorizing the sale of the school sections adjacent to the city property.

Contracts for the first grading were let in February, 1910, when work was started on 12 miles of the speedway. Dedication of the opening of the first 17 miles completed was marked by an automobile parade of more than 200 machines. Diagonal boulevards extending from the central portion of the city to the outer or Grand Boulevard are to be constructed. The routes outlined for these as well as practically all parts of the speedway afford a splendid view of the city.

The four sides of the boulevard are distant from the present business center substantially 3 1-2 miles to the north and 3 miles to the east, south and west. The circumscribed territory (about 46 square miles) will accommodate only 184,000 persons, figuring

on a basis of 4,000 inhabitants per square mile; so it will appear that Oklahoma City is making a wise move in obtaining these valuable bits of land for the speedway and park and parkway purposes while it has a population of only 65,000 and is still the largest city in the State.

### Wisconsin Adopts State Aid

MILWAUKEE, Aug. 14—"The knell of the road working picnic has been tolled. We have passed the day when the working out system of road taxes is advisable or feasible. Wisconsin has joined the ranks of the progressive States which have by systematic work produced admirable systems of highways."

In these words John A. Hazelwood, of Jefferson, Wis., former State Senator and chairman of the Wisconsin Highway Commission, created by the 1911 Legislature, sounded the keynote of the board's future activities in an address before the Dodge County Board of Supervisors at Juneau, Wis., last week. It was the first public statement by a member of the commission and formally introduced State aid for highway construction.

Acting under the new law appropriating \$350,000 each year to counties which expend an amount equal to their respective apportionments, the Dodge County board has already started a constructive program, being one of the first counties to take advantage of the new act.

"This State has practically stood still in the matter of building permanent highways," said Mr. Hazelwood. "On the other hand, 75 per cent. of the States of the Union have made marked progress. Central governments all over the world have generally employed the policy of State or Government aid. Most States have adopted some form of a State aid policy. For liberality we have been far outdone in Wisconsin by Minnesota on the start. Money invested in improvement of highways is like 'casting bread upon the waters.'"

"One of the most pleasing features of the new Wisconsin act is that it provides a fine example of the initiative. It is up to townships or public-spirited citizens to ask for road improvement. And to those that ask will be given."

Up to this time roads have been built in a haphazard manner. A farmer could work out his poll tax by putting in one day on the highway. One or two farmers went on the road with teams and did more damage than good. All of this work is now stopped and a systematic program substituted.

## Clans Gather for the Elgin Races

CHICAGO, Aug. 14—The racing clans are gathering for the American Automobile Association's national stock chassis road races which will be run at Elgin August 25-26. Several have been in camp for a week past, but the bulk of the drivers get there this week. The Alco team has been at the course for a week now, Maisonville of the Corbin and Jeffkins of the Velie have been out there several days, while others came in to-day.

Official practice starts Friday and from 11 a. m. to 1 p. m. each day the throttle can be opened under the supervision of the officials. Flagmen will be on duty, and in addition three officials of the Motor Race Drivers' Association will be present to superintend the practice. It is the intention of the Chicago Motor Club to have a medical examination of the drivers and if any of them are deemed incapacitated they cannot start.

Only one entry has come in since last week. The Ford Motor Company has nominated a car for the Aurora cup with Frank Kulick to drive. Now there are thirty-three entries in the four events. In the Elgin National for the under 600 class there are: Mulford in a Lozier; two Nationals, drivers unnamed; Grant, Lee and Hartman in Alcos; De Palma and Wisheart in Simplexes; Buck in a Pope-Hartford; Hughes in a Mercer, and Burt in a Cino.

The Illinois cup race on the first day, for the 301-450 class, only has four named so far, two Nationals and a pair of Velies, with Stickney and Jeffkins as the Velie drivers. In the Kane County cup for the 231-300 class, there are three Falcars, three Stavers, three Colbys, two Coles, two Mercers, two Cinos and a Corbin. The Aurora cup race for the 161-230 class has in it an Abbott-Detroit to be driven by Mortimer Roberts and a Ford to be handled by Frank Kulick.

Additions to the prize list have been made by the accessories people and now there is hung up a total of \$5,250 exclusive of the cash offering of the Elgin Automobile Road Race Association, \$2,500. The Remy Electric Company to-day gave \$1,200 conditional on the winners using Remy ignition, \$250 for first, \$100 for second and \$50 for third being offered in the Elgin National, Illinois and Kane County. The Dorian Demountable Rim Company is offering \$250 to the first man finishing on Dorian rims in the big race, \$150 for the first one in the Kane County and \$100 in the Illinois. The makers of the Sears & Cross type of speedometer will give \$200 to the users of their device.

## New Knox Water-Tower Tried Out

Springfield, Mass., had its first glimpse of an odd-looking piece of fire-fighting mechanism the other day when the new Knox water-tower, designed by Charles H. Martin, was tried out in the vicinity.

The device consists of a steel frame, carrying a motor and transmission machinery which is placed in front of a fire engine, or other apparatus, designed to be horse drawn. It rests on the front axle of the vehicle to which it is attached. In front it is supported by a single wheel, or two wheels placed close together. This construction gives it a more or less freakish appearance, but is said to be necessary in order to make short turns and handle the vehicle in narrow streets.

The frame is supported on easy springs in both front and rear, which prevents the engine and drawing mechanism from being shaken to pieces on rough roads. The engine is geared by means of chains and sprockets to the front wheels of the vehicle, the whole making a complete motor-drawn piece of fire-fighting apparatus.

## Mead Temporarily Heads General Motors

DETROIT, Aug. 14—An event of general interest throughout the trade is the departure of President Neall of the General Motors Co. to Europe on a prolonged trip.

During his absence the affairs of General Motors will be managed by what is known as the "President's Council," of which W. J. Mead, vice-president of the company and manager of the Oldsmobile plant, is chairman. Mr. Mead will move his headquarters to Detroit during Mr. Neall's absence. The other members of the council are Gleeson Murphy, assistant to the president; treasurer, James T. Shaw; secretary, Standish Backus, and director of production, Tracy Lyon.

## Rebuilding Old King's Highway

SANTA BARBARA, Aug. 14—One of the most unique good roads campaigns ever conducted in this country is at present being waged there. It has as its object the raising of the sum of \$100,000 for the construction of what will be known as the Rincon road.

The Rincon will be a sea-level road, from Ventura to Carpinteria, 12 miles south of here, shortening the distance along the coast road 9 miles and, what means more, overcoming the dangerous Casitas pass.

This pass is one of the dangerous features of the coast highway. It has many turns. The road is narrow and is impossible to keep in fair condition at all seasons of the year. To a tourist who is not thoroughly familiar with it danger lurks at every turn.

Half of the money needed is being raised by voluntary subscriptions, and the main campaign is being conducted from here, the Santa Barbara Chamber of Commerce having taken the initiative. Acting on the most important sub-committee are Milo M. Potter, proprietor of the Potter Hotel; Louis Jones, president of the Chamber of Commerce, and Phil H. Rice.

## \$1,000,000 Company to Make Motors

FLINT, MICH., Aug. 14—The Mason Motor Company has filed articles of incorporation with the Secretary of State.



Water tower, with Martin tractor in front, recently built by the Knox company for the Springfield, Mass., fire department

The capital stock is \$100,000. All of the capital stock has been paid in, it is reported.

The new concern will engage in the manufacture of engines for automobiles and plans have been made for carrying on the business of the company on an extensive scale.

The company has closed a two years' lease of a large four-story building in the Fourth ward, adjoining the Flint wagon works, which will suitably lend itself to the purposes of the new company. The building is 85 x 65 feet and has a flood space of about 5,500 square feet.

The plant will be ready to begin operations in about two weeks and it is expected that by next spring it will give employment to at least 500 skilled mechanics. The capacity of the plant will be forty engines per day.

The Mason company will make engines for the new Chevrolet cars, which are to be built in Detroit until a permanent site for the Chevrolet Motor Company's plant is selected.

The principal incorporator of the new company is Arthur Mason, of Flint, who will have entire charge.

## Six-Cylinder Knight Introduced in America

The 1912 announcement of the Stoddard-Dayton car brings forth the fact that the six-cylinder Knight with the cylinders cast in groups of three has found its way into this country. The practice of casting the cylinders in groups of three has been in vogue in Europe and it has been found that with the seven-bearing crankshaft great rigidity can be obtained.

While the announcement of the 1912 Stoddard-Dayton cars includes twenty-five different models, there is one type which perhaps will excite as great an interest as any of the products brought out during the present year, since it embodies the introduction of the six-cylinder Knight motor to America.

This motor is placed in six different types of bodies; a seven-passenger touring, seven-passenger limousine, and six-passenger torpedo. The same chassis reduced to a wheel base of 122 1-2 inches is adapted to a four-passenger torpedo or a two-passenger roadster.

Convenience has been made an aim by providing large and water-tight baggage compartments on the roadster, which can conveniently carry two large suit cases.

### Midsummer Show Is Planned

DES MOINES, IOWA, Aug. 14—Des Moines automobile dealers will hold a big automobile show in connection with the Iowa State fair, the last week in August. W. E. Moyer, president of the local dealers' association, C. G. Van Vliet, secretary, and George Harritt are in charge of the affair and 30,000 square feet of floor space has been reserved by the local dealers. A big floral parade is to be pulled off August 26.

### Receiver for Fal Company

CHICAGO, Aug. 12—The Fal Motor Co., of Chicago, maker of the Falcar, went into the receiver's hands to-day when Referee in Bankruptcy Wean named Edward C. Day, a lawyer, as receiver. The application was made by a creditors' committee consisting of H. K. Gilbert, of the Buda Co., A. H. D. Altree, of the Bosch Magneto Co., and H. H. Seaman, of the W. S. Seaman Co. The value of the assets is placed at \$75,000 and the liabilities at \$150,000.



Part of the battery of White trucks which took care of the transportation end of the recent maneuvers of the Massachusetts militia

Just what the receiver will do has not been determined. An inventory is being taken now and when that is completed a policy will be outlined. However, it has been determined to finish up the cars now on hand. The creditors' committee has made a statement relative to the receivership appointment.

### Trucks Take Place of Wagon Train

Among the trucks used in connection with the recent maneuvers of the National Guard of Massachusetts were a number of standard types of three-ton capacity. The trucks, numbering about twenty, were used by the troops in place of the antiquated wagon train of other days. The trucks did the work of fifty or more wagons and demonstrated that the automobile is vastly better adapted to this sort of work than the horse-drawn wagon. There were five Whites and several Kissel trucks.

### Axle Plant Much Enlarged

JACKSON, MICH., Aug. 14—The new Lewis Spring & Axle Company plant, Horton street, is nearing completion. It will afford employment to about 200 additional men. The Park avenue plant of the company will be vacated upon the occupancy of the new building.

The new factory is 250 feet square and has a total floor space of 62,500 square feet. It is a one-story structure of light red brick with ample provision made for fine light and ventilation.

### Mitchell Agents Prepare Campaign

RACINE, Aug. 14—On August 11-12 about 100 agents of the Mitchell held a reunion at the factory of the Mitchell-Lewis Motor Company, Racine, Wis. They inspected new models and lined up a campaign for the coming year under the direction of Wm. L. Day, general sales manager.

### Shiland Takes Hold of Westcott Sales

RICHMOND, IND., Aug. 14—H. E. Shiland has been appointed general sales manager of the Westcott Motor Car Company. Mr. Shiland was formerly sales manager for the Buick Motor Company.

### Will Sell Matheson Cars

WILKES-BARRE, PA., Aug. 14—The Matheson Automobile Company, of Wilkes-Barre, announces the appointment of H. De Long Fry, of Albany, N. Y., as assistant sales manager.

# New Things Among the Accessories

## Gasoline Economizer and Filter

PERFECT vaporization of the gasoline used as fuel in internal combustion engines is an absolute requirement for success along this line of endeavor, and while this need is recognized by all engineers there are many of them even to-day who look at an incomplete evaporation as a necessary evil that there is no way to avoid. The cause of inefficient vaporization lies often in the construction of the carburetor nozzle, resulting in a thin and straight jet rather than the formation of a broad cone of gasoline-air mixture. While a good deal of gasoline is vaporized even by the nozzle termed inefficient, the gasoline is not torn up in globules small enough not to accumulate in drops when striking the metal surface of the manifold. Under the circumstances it is even difficult to prevent liquid gasoline particles from entering the combustion chamber, where it has to be vaporized by the engine heat of combustion, thus detracting from the useful work of the machine.

In Fig. 2 is shown the proper way of atomizing the gasoline, which, when leaving the nozzle, is torn up into infinitely small particles and by centrifugal action made to form a cone-shaped mist. At (B) the effect of a straight-jet nozzle is shown, and while the illustration may be somewhat exaggerated it serves well to bring out the difference of the two principles. The reason for this difference in action lies in the manner of construction of the two nozzles used, and, broadly speaking, the pressure under which the liquid is expelled through the nozzle orifice. As will be seen, the pressure is much higher in the case of the conical spray than where the straight jet is formed.

The conical spray here reproduced has

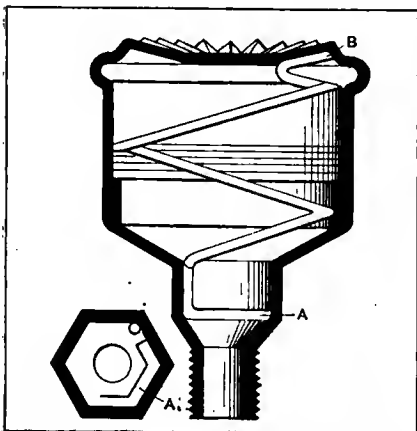

Fig. 1—Merchant & Evans securely fixed grease cup

been obtained by the use of the Mills petrol economizer and filter, three views of which are shown in Fig. 3. At (A) it is seen how the economizer is made so as to screw into the passageway leading from the float chamber to the vaporizing space, while (B) illustrates the arrangement of the economizer for use in the well-known Longuemare carburetor. The economizer B having an outlet A is fitted in the vertical continuation of the passageway H by the use of a flange D tightened by the leather washer E which prevents the gasoline from flowing upward through the holes G. F is the economizer inlet. The construction of the device itself is brought out in (C) where D is a stationary nozzle located inside the outer nozzle A1. The adapter A which helps to fit the economizer in a carburetor instead of the nozzle furnished therewith contains a wire-gauze filter which keeps all foreign matter from entering the inner economizer space B. After passing through this filter, the gasoline flows up

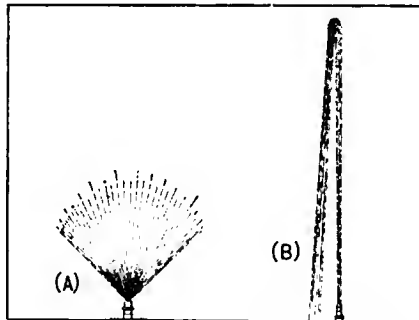

Fig. 2—Gasoline atomized spray and straight jet

through the tube D, leaving it through two skew holes at the top. By this arrangement the liquid is made to swirl before it leaves through the orifice C, and this revolving motion in addition to the high pressure created by the use of the cylindrical space C results in centrifugal action which throws the gasoline out toward the sides of the nozzle, causing it to form the conical spray on account of its being mixed with the atmospheric air.

The economizer and filter is made by H. E. Mills, 441 Brighton Road, S. Croydon, Surrey, England, and is applicable to the use of gasoline, benzol or paraffine. The size of the engine may necessitate an enlargement of the orifice C, but in making this adjustment care must be taken so as to make the hole not too wide, since this would tend to destroy the conical shape of the gasoline-air jet and to form a straight jet, thus robbing the device of one of its most valuable features.

## Securely Attached Grease Cup

MANY parts of the automobile are lubricated by means of grease cups which are filled with the lubricant and then left in place for a number of days or weeks. This makes the method of lubricating such parts a very comfortable matter, or would make it one were it not for the

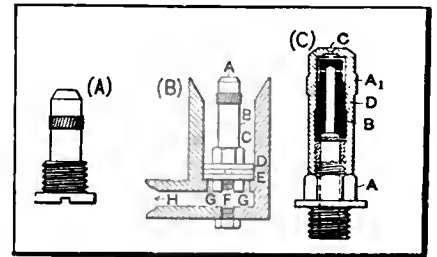

Fig. 3—Details of Mills Economizer and Mixer

fact that in course of time the caps of grease cups tend to come off and that, therefore, it will be necessary for the automobilist to inspect, at frequent intervals, the places so lubricated, only to find out whether the grease cups are still in place.

To relieve a strained situation, an attempt has been made to construct a cup that won't come off, which is shown in the accompanying Fig. 1, it being a product of the Merchant & Evans Company, of New York, Chicago, etc., known as manufacturers of transmissions, alignment joints and so forth. The grease cup mentioned contains a spiral wire, as may be seen from the illustration, one end of the wire is hexagonally shaped, fitting in the hexagonal shank shown at A, its form positively preventing it from turning.

The other end of the wire is made to act as a pawl. Looking at the top of the cup reveals a corrugated surface, and the end of the spring B engages with this corrugated surface, but does not interfere with the screwing down of the cap. Turning the cap causes the wire end to slip from one corrugation to the other, holding at the same time the cap in secure relation. As the wire is spiral in shape it serves as a spring holding the pawl end firmly against the top of the grease cup. The operation of this type of cup is exactly the same as that of any other kind, by means of the fingers of one hand, the interior wire mechanism adding no complication to the handling of the device.

## Solderall Compound

SOLDERING is an operation which, according to general belief, requires a very hot flame, a blow-torch and consider-



able skill to get up a good connection between two pieces of metal, but there has appeared on the market a pure tin solder which permits of soldering without the appliances heretofore considered absolutely necessary for doing this work. The tin contained in Solderall, as the compound is named, is combined with a non-corrosive flux having the consistency of a paste, which melts at the low temperature produced by a burning match. After cleaning the metal surfaces to be soldered from the oxide, which always covers such exposed parts, a little paste is smeared over them, and after placing them together in the position that they are desired to hold after

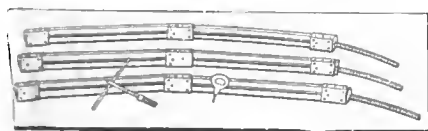

Fig. 4—Elements of the Fudge emergency tire

soldering, heat the parts covered with the paste by means of a match, a candle or a torch. The special composition of the solder assures its melting within a few seconds, after which the metal parts are allowed to cool off. A test made will show that the work has been done efficaciously, and the solder will be at least equal in strength to the component members. This solder is made and marketed by the H. W. Johns-Manville Company, of 100 William street, New York.

### Sectional Emergency Tire

IN Fig. 4 the elements of the Fudge Emergency Tire are illustrated, and, as the cut shows, they are in the shape of flexible but solid strips of material, being capable to be connected up by the operation of a simple mechanism. A flexible rack is securely fastened to one end of a tire element, while the other contains a guideway for the rack. This guide contains another rack meshing with the teeth of the rack first mentioned, and also with a pinion stationed in the center of the tire element.

If it is desired to mount the Fudge which is applied over the regular pneumatic tire, the three elements are connected by means of the racks, leaving the tire ring open in one place, as indicated in Fig. 5. Then the emergency tire is placed on the floor, taking care to get no grease on the emergency tire, since this substance does it no more benefit than it renders a pneumatic. The wheel on which the Fudge tire is to be mounted is then rolled on the emergency tire, until the position illustrated in Fig. 5 is reached. Thereafter the opening between the two tire elements shown in the figure is closed up by locking the two racks, and to tighten the elements of the tire against each other the pinion wrench shown in Fig. 4 is used. The wrench is inserted into the opening located

in the center of each element, and since it fits the hub of the inner pinion it is possible to turn the latter by means of the wrench, thereby bringing the two racks into closer engagement. This procedure is continued until the ends of each two elements meet, when sufficient tension will obtain. In order to remove the emergency tire from the wheel the release pin seen in Fig. 4 is used. For this purpose the pinion is given a short turn with the wrench, tightening it a little, and then the release pin twisted as far as possible toward the pinion; thereafter the wrench is made to turn the pinion in the opposite direction and promptly unlocks the racks it controls.

While the two illustrations here given are of the three-section type of emergency tire, the Fudge Brothers Manufacturing Company, of Marion, Ind., also make a two-section and a four-section type, the operation of which is identical with that of the three-section class.

### Auto Heel Rest

FATIGUE is the demon that interferes with efficiency in personal work, and to increase efficiency some men directing manual or, speaking more generally, cor-

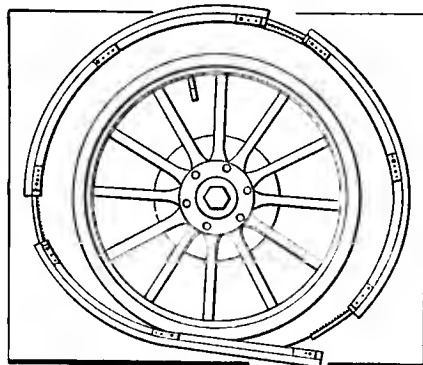

Fig. 5—Mounting the Fudge on a pneumatic tire

poral labor, have found it of advantage to make a study of the motions of which the operations of the laborers are composed. It is the useless strain that brings about early fatigue and, remembering that the chauffeur, who is bound to keep his foot on the pedal when driving, does the work with his sole, it would be a step in the right direction were he to be freed of the hard work of pressing his heel against the floorboard without finding a positive fulcrum.

Recognizing the reduction of the useless strain on the chauffeur if his heel is afforded a positive resting place, L. Lucas & Son, of 3 Fox street, Bridgeport, Conn., have constructed and placed on the market the simple and practical footrest which is shown in Fig. 6. The footrest here illustrated is cast of aluminum and in the shape of a rectangular prism, 4 inches long by 2 1-2 inches wide, and about an inch high. There is no baseplate, but in-

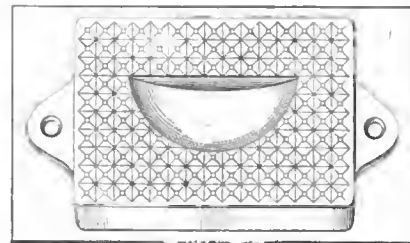

Fig. 6—Auto heel rest, which is cast of aluminum

stead of it two flanges are cast integral with the two vertical sideplates, permitting the footrest to be attached to the footboard by means of two screws and nuts. The footrest is preferably attached so that the foot poised on the cavity of the footrest is in position to operate the accelerator. In addition to giving the heel a strong hold, the Auto Heel Rest brings the foot higher up, which permits the driver to work with his foot with less strain on the muscles of his leg, thereby protecting him from unnecessary and early fatigue in driving.

### Coupling the Magneto to the Drive

THE coupling illustrated in Fig. 7 consists of two parts, one being cone-shaped with a crown end, while the other is a cross-piece of special construction. The crown carries two diametrically opposed slots which are lined with fiber. In these slots fit the ends of the cross bar, which on examination is found to consist of a great number of laminations of fine spring steel. By virtue of the spring the looseness and pounding, which may be produced with the ordinary coupling under varying resistance to the rotation of the armature, are entirely absorbed and the armature, in consequence, runs with much greater smoothness than is obtainable with any former type, and with absolute silence. Furthermore, there is sufficient spring in the cross section of the laminations composing the cross-bar to permit the magneto to run with the armature shaft at an angle with the drive shaft.

The coupling thus becomes a universal joint, for it not only gives a drive with the two shafts off center, as is the case with the ordinary Oldham coupling, but in addition permits the shaft to run out of line. This coupling is made by the Bosch Magneto Company, 225 West 46th street, New York City.

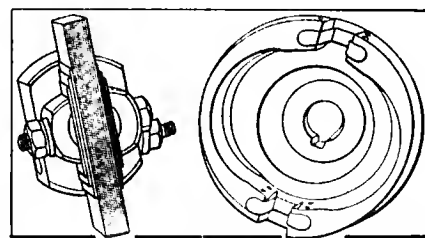

Fig. 7—Bosch coupling for driving the magneto

## Seen in the Show Window

**P**RECISE measurements are at the foundation of standard methods of production, and they are applied not only to the material as it is worked into the machines being made, but the power output and its component factors are also submitted to a series of exacting tests. The tachometer, shown at BU, is built for exact measurements of the engine r.p.m. and consists of a dial upon which the speed of the engine is indicated, the operation being similar to that of an electric meter. To measure motor speed, the part of the tachometer, which is connected to the dial by insulated wiring and which contains a small direct-current magneto, is applied to the engine to be tested in the usual way. The strength of current in the magneto varies directly with the engine speed actuating the magneto, so that correct readings are obtained for all the r.p.m.'s indicated on the dial. It is made by the Electric Speedometer Company, of Washington, D. C.

**O**BVIOUS advantages accompany the use of acetylene in automobile illumination; brightness and cleanliness are the principal virtues of this system hardly to be surpassed for effectiveness. The Tri-Radiant burner BV is so constructed as to light the road in front of a car as well as the fields alongside of it. A triple burner, of which this lighting system has derived its name, produces enough light to brightly illuminate the road as well as the portions of the land neighboring it, the effect of the triple burner being assisted by a system of lenses which properly distribute the light. This type of burner is handled by the Lenhart Manufacturing Company, Inc., 246 North Delaware avenue, Philadelphia, Pa.

**L**IMITED as the supply kept in the gasoline tank must necessarily be, it is bound to give out at some time or other, and the automobilist generally finds himself in an out-of-the-way locality when the emptiness of the tank manifests itself. To avoid such a situation a gasoline gauge will be a useful accessory to install on an automobile. In this connection the Smith gasoline meter, shown at BW, is interesting. Placed on the dash, in a conspicuous position, it shows at all times how much the tank contains, and an occasional look at it will keep the driver out of such a disagreeable situation as getting stalled on a hill, miles away from the nearest garage. The gauge fits all makes of cars and is guaranteed for two years by the Smith Gasoline Meter Co., 1777 Broadway, New York City.

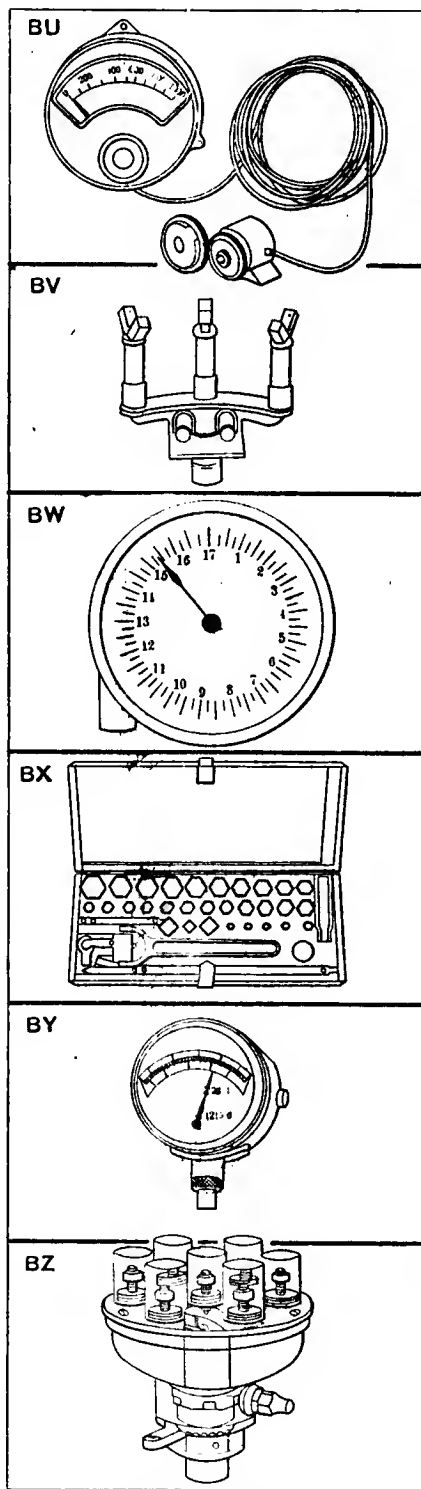

BU—Electric Speedometer Company's Tachometer for measuring engine speed  
 BV—Tri-Radiant acetylene has wide range and great illuminating power  
 BW—Smith gasoline gauge saves trouble arising from an empty fuel tank  
 BX—Bay State autokit overcomes stubbornness of standard-dimensioned nuts  
 BY—Sears-Cross speedometer opens the driver's eyes in regard to his speed  
 BZ—Leavitt distributor simplifies internal-combustion ignition systems

**I**NACCESSIBILITY of nuts is a derogatory feature of chassis construction, but it stands to reason that to get at these unruly portions of the automobile's mechanism is no more difficult than to screw them on. It is only a matter of having and using the right kind of tool, and a normal amount of mechanical skill will suffice to get at and remove the nut in question. In the Bay State Autokit, which is illustrated at BX, a substantial wrench is contained, together with the necessary fittings to give it a solid grip on all standard-dimensioned nuts. The equipment is handy and takes up little room, being enclosed in a flat case, and is sold by Geo. A. Cutter, Taunton, Mass.

**I**T is of great importance for the driver to always know the speed at which his car is traveling, and speedometers are today part of the equipment of practically all cars in operation. One of the popular types is here shown (BY); it is made by the Sears-Cross Company, of 687 Eleventh avenue, New York City, in five styles. There are no magnetic parts contained in this speedometer, and its operation is purely mechanical, so that it may well be expected to work correctly under all weather conditions. As the illustration shows, the dial contains a speed indicator, showing the velocity up to 60 miles an hour; also a trip mile indicator, which may be set to zero at the will of the operator, and the "total" mileage indicator, showing the number of miles traveled by the car since the installation of the speedometer which is placed on the dashboard.

**T**HE early introduction of multiple-unit coils is largely responsible for their being found in far more ignition systems than are distributors combined with single-unit coils. This statement is proved by the fact that owing to the merit of distributors these are continually being used, and to some degree, increasing in numbers, and are giving satisfactory results. The Leavitt Improved Distributor (BZ) is made to work on from  $\frac{1}{4}$  to  $\frac{1}{2}$  ampere current, while the timer vibrator can be adjusted to take from  $1\frac{1}{2}$  to 2 amperes. As a result of these excessive burning is caused at the contact points. In the Leavitt the points are made of iridium, an inert metal subject to no chemical changes in consequence of the electric strains placed on it. The distributor here shown is made for engines with any number of cylinders, from two to eight, by the Uncas Specialty Company, of Norwich, Conn.

# THE AUTOMOBILE

## Making Motor Trucks Stay Sold How Sellers Keep Watch of Cars in Service

*Progress in introducing automobile trucks is vastly helped if the cars in service are kept in a state of efficiency and in order to reach that end nearly all the sellers of trucks keep some kind of official or unofficial supervision of their product in the hands of purchasers. These systems of inspection are extremely varied, but they are all directed toward keeping the cars on the road in shape to perform their duties with economy.*

**I**NTRODUCING automobile trucks to the commercial world differs diametrically from the selling of pleasure cars to the general public. There is little in common between the two great branches of marketing cars. On the other hand, the pleasure or utility automobile designed to carry passengers primarily for pleasure, but frequently for business, as in the case of physicians,

of trucks only considers performance as the prime requisite. On the general average it has been demonstrated that it costs approximately 19 cents a mile to operate a passenger automobile and only a comparatively few owners scan the cost figures with searching care. On the other hand, the concern that uses automobile trucks in its business enters and compiles each item of



A—INSPECTING CARS FOR EXCESSIVE LOAD BEFORE STARTING 14-MILE RUN TO SUBURBAN DEPOT OF BIG RETAIL STORE

contractors and salesmen, affords an entirely different selling angle from truck distribution.

The man who buys a car for personal transportation is moved most forcibly by the appearance, price, speed, beauty, silence, grace of performance of the automobile presented, but the buyer

cost with the most scrupulous care. If gasoline consumption shows higher than its normal level; if the tire mileage is less than the purchaser of the car had been led to believe it should be; if the car has to be shopped more frequently and consequently is put out of service longer per month than the owner



C—Small Lansden car used for city deliveries  
D—Pair of White trucks transferring freight from warehouse to depot

B—Automobile trucks have widened the scope of retail merchandizing and great care is used in maintaining the cars

thinks it should be, the makers and sellers of the car hear all about it immediately.

In the general movement which is now in progress toward the motorization of all trackless travel, probably one-quarter of the horses that have been displaced by automatic power have fallen before the passenger automobile of private ownership. Fully three-quarters of the jobless horses have resulted from the competition of the truck and even at that the motor truck has provided much work for the equines by extending the scope of business, thus furnishing a use, even if it is only temporary, for thousands of horses that had been originally displaced by the installation of the more economic form of transit.

Service departments for quick, economic and skillful repair and maintenance work have been established pretty generally where there are large numbers of any of the standard makes of automobiles in use and recently the scope of their work has been largely increased by including the trucks within their jurisdiction.

As a general proposition trucks are sold under a guarantee as to materials and workmanship and where a part yields through latent defect and without fault of the operator and owner it is replaced by the selling company without cost.

In the past this provision seemed more important than it does at present, for with the improvement in the methods of manufacture the chance of including some defective part in the assembled car is reduced and the chance of discovering it before it leaves the factory is increased. Then, too, designing has progressed enormously in all directions and the class of materials is better than it was in the early days of truck manufacture.

All these things lend themselves to longer life in the truck and more satisfactory service.

But now after several years of trial and experiment the automobile truck is coming into its own. The manufacturing companies that have alertly followed the trend of events find themselves with more business than they can handle and each day finds many more trucks in service in all lines of commercial work. Buyers are no longer moved to purchase on insufficient grounds. They want to know what the car will transport goods

per ton-mile by the year and how much it will cost to keep the car on the road and up to its highest efficiency. The price is important, too, but not the prime essential. For certain classes of work the owner asks himself not: "Can I afford to pay the price?" but "Can I afford not to pay the highest price?"

The only reason that the truck has obtained a foothold in the commercial life of the world is founded on its service. If a concern invested \$50,000 in trucks and for any reason they were laid up half of the time, the future business in the truck line of that concern would be difficult to get.

The transition from horse-drawn traffic to motorization as far as it has progressed is due to the fact that the trucks do more work than horses at less money cost. Any time that the reverse condition obtains the automobile truck business will decline and die. The single question that confronts all hands identified with the making and using of trucks is service and in order to solve the problem the sellers of trucks keep a fatherly eye upon their product during the life of usefulness.

The system is known by various names in various companies, but its object is the same in all of them, namely, to keep their cars on the road and in condition to earn money for their owners.

When a big concern decides that in order to keep up with the business procession the time has arrived to motorize its transfer and delivery departments, the practice in the past has been to simply buy as few trucks as the salesman will allow them and then to turn over this equipment to the barn boss of the concern with orders to sell off the horses and get busy with the new equipment.

The barn boss may know all about horses and nothing at all with regard to automobiles. This condition is likely to be fiercely accentuated as it applies to his drivers. Putting a mule driver behind the wheel of a \$5,000 truck has been quite an ordinary experience and needless to say has proved costly. There is nothing supremely difficult about driving a commercial car. The mechanism is simple, the controls easily mastered and the main principles are not specially involved. Many a horse-driver has made good as an operator of a power truck without special



G—Starting small truck on its daily journey of sixty miles—note the care used in packing the load

E—Randolph truck used for the long hard runs in suburban delivery  
F—Heavy duty Alco truck with a load of pianos

schooling, but the percentage of failures in this regard is appalling. The steering presented few difficulties and control was not very puzzling to the average alert driver. The brakes proved bothersome and when it came to the mechanical processes the horse driver was not at home. It took him a long time to learn that lubricating oil in proper quantities was more essential to operation than gasoline and that a burned-out bearing was more serious than a balky team.

Consequently the education of the barn boss and the driver is of great importance when the concern contemplates motorizing its transportation system. The essential character of education in this line has always been recognized by those closely in touch with the industry. The Y. M. C. A. has conducted schools in which drivers and operators of trucks may receive instruction as to their duties, and the New York Fire Department is about to institute a school to train drivers and mechanics for its new power-driven fire apparatus. On July 27 the Packard Company announced that it would maintain a school of instruction for operators of its cars owned by commercial concerns and at the first session of this school there were over twenty students present.

In all these schools the main object to be attained is to emphasize upon the minds of the students the necessity of not doing certain things. Of course the instruction includes affirmatively what should be done ordinarily, but it brings out sharply the necessity for not doing certain things under emergency conditions. These prohibitions include such things as avoiding the attempt to repair a broken crankshaft on the road; or adjusting the magneto; attempting to run without water or oil and a dozen other phases of impossible motoring, at least as far as the inexperienced driver and mechanic are concerned.

The school idea is excellent and in the course of time the business of driving will be on a materially higher plane than it is at present. In fact education is probably the most important thing about operating a truck, because when the operator of a commercial truck knows just what to do, a vast amount of trouble will be saved to the makers of the cars and

a vast amount of additional service will be insured to the owners thereof.

The present practice in marketing trucks is to extend the interest of the manufacturers of the cars to their service, as long as they shall remain in service, with the idea of making this period of useful life as long as possible.

The service departments established in many sections are one of the channels through which the manufacturers extend their interest, but in addition to the actual repair departments the system of inspection referred to above is coming into more general use with each season.

There are a number of these systems in operation, ranging all the way from a kind of street-detective plan by which truck experts examine cars made by their company with or without the knowledge of the drivers and report to the owners of the trucks that certain things are amiss and should be corrected, to an elaborate plan of instruction, personal help, periodic inspection and complete reports on the condition of the cars, such as is the plan kept in operation by the Packard Company, for instance.

One of the typical systems in general use in New York and elsewhere may be described briefly as follows:

When a truck is sold the company selling takes the foreman of the purchasing concern under its wing and instructs him in the mechanical principles of the car and teaches him the details of operation. Then for two days, an expert is detailed to go along with the driver of the car to inform him of its workings. After this the company makes regular inspections of the car and recommends changes, alterations, adjustments and repairs.

In carrying out this plan of comprehensive interest in its cars the following forms are used. The first is a form used in making either regular inspection reports or incidental reports. If one of the cars happens to be seen by an inspector and its condition is not first class, he makes out a report covering the case and as much of it as is necessary is transmitted to the owner with recommendations. Naturally these incidental





H—Unloading a shipment of big metal receptacles from a Randolph car

reports are not so complete and detailed as those which follow regular inspections, but they may be made on the same form, which is as follows:

**TRUCK INSPECTION REPORT**

..... Date .....

..... Motor No. .... Wagon No. ....

Motor.....	Chains.....
Carbureter.....	Transmission.....
Circulation.....	Wheels.....
Ignition.....	Tires.....
Clutch.....	Springs.....
Steering Gear.....	Mileage.....
Lamps and Horn.....	Body.....
Lubrication.....	Driving.....
Brakes.....	General Care.....

Remarks: .....

Signed.....

As a cross check on the cars some of the companies urge a careful tabulation of each item of daily expense on each car operated. These tabulations give mileage, material and other items in the daily cards and these totals are transferred to monthly reports from which yearly records are made up. By simple divisions, the wagon mile cost and ton-mile cost may be deduced as applied to total expense and with relation to each of the various factors that go to make up operative costs. These, as have been shown authoritatively in THE AUTOMOBILE, consist of tires, fuel and oil, garage work and supplies and do not take wages of crew and garage rentals into consideration.

The forms are as follows. The first is the daily trucking sheet:

**DAILY TRUCKING SHEET**

Truck No. .... Driver..... Date.....

Material	Quantity	From	To	Arrived	Left	Miles

The second is the monthly expense statement:

**MOTOR TRUCK EXPENSE STATEMENT**

No. of Truck..... Driver..... Month.....

	1	2	3	4	5	(to 31)	Total	Daily Ave.
Wages (including overtime).....								
Expense, Help, etc.....								
Garage.....								
Washing Car.....								
Gasoline.....								
Lubricants.....								
Tires.....								
Other Supplies.....								
Repairs to Machinery (Routine).....								
Repairs to Machinery (Accident).....								
Repairs to Body and Gear (Routine).....								
Repairs to Body and Gear (Accident).....								
Total Daily Operating Cost.....								
In Service.....								
In Shop.....								
In Reserve.....								
Daily Mileage.....								
Daily Load.....								

The third is the yearly statement:

**MOTOR TRUCK EXPENSE STATEMENT, 1911**

No. of Truck..... Capacity..... Cost \$..... Put in Service.....

	Jan.	Feb.	(to Dec.)	Total for Year	Average per Month
Wages (including overtime).....					
Expense, Help, etc.....					
Garage.....					
Washing Car.....					
Gasoline.....					
Lubricants.....					
Tires.....					
Other Supplies.....					
Repairs to Machinery (Routine).....					
Repairs to Machinery (Accident).....					
Repairs to Body and Gear (Routine).....					
Repairs to Body and Gear (Accident).....					
Total Monthly Operating Cost.....					
Number of Days In Service.....					
Number of Days In Shop.....					
Number of Days In Reserve.....					
Monthly Mileage.....					
Average Daily Mileage.....					
Month by Load.....					
Average Daily Load.....					
Operating Cost per Day in Service.....					
Operating Cost per Mile.....					
Operating Cost per Load Unit.....					
Insurance..... (%).....					
Depreciation..... (%).....					
Interest on Investment..... (%).....					
Taxes..... (%).....					
Total Fixed Charges.....					
Total Cost per Day in Service.....					
Total Cost per Mile.....					
Cost Gasoline per Mile.....					
Cost Lubricant per Mile.....					
Total Cost.....					

Thus at the end of a period of years the owner knows to the fraction of a mill what it costs him to operate each of his trucks. The daily reports always give warning of coming mechanical troubles and by keeping watch of them serious lay-ups may be avoided and the mileage of the car kept up to its normal without mountainous expense.

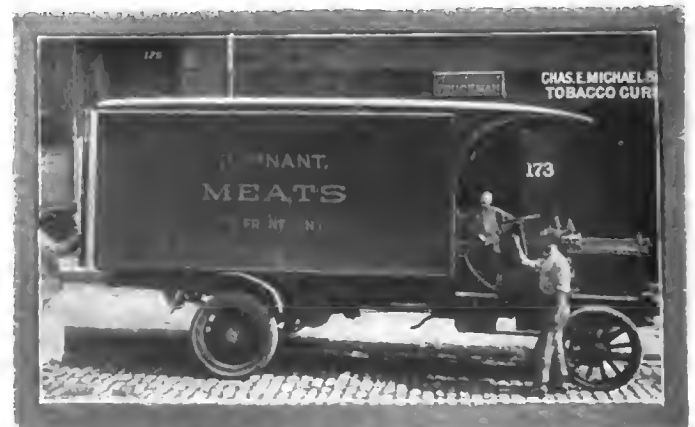

I—The factory inspector may be present incognito to note the condition of cars

He can tell at a glance how long the car maintains its highest efficiency and exactly where expense begins to pile up, indicating the need of overhaul and replacements. Also by comparison with reports of other years or months covering the same trucks he can tell whether repairs have proved effectual in checking operative expense along lines that appeared excessive.

Undue quantities of fuel or oil used in operation stand out sharply from the normal or average level and excessive speed has its inexorable effect upon the cost of tires and mechanical upkeep. There is no need of an automatic governor to limit the speed of cars if the daily report sheets are read understandingly. A car that is capable of fifteen miles an hour as a normal speed rate shows the effect of twenty miles an hour in its tire consumption and maintenance bills as certainly as the square of the velocity represents the rate of deterioration of mechanism and increase of tire costs.

The use of the motor truck has become very general in the metropolis and has worked a revolution in the transfer and delivery of goods. To a large extent this good work has resulted from the various systems of inspection on the part of the sellers of the cars. The field has been widened enormously and the merchant who does not take advantage of the improvements offered in transportation is in an uncomfortable position.

Several of the big retail establishments, such as R. H. Macy & Company, have adopted the automobile in whole or in part in their transfer and delivery systems. At Macy's, for instance, a whole fleet of small electrics is used for urban delivery. These cars are specially available for crowded city work. They take up small storage space and have proved to be satisfactory for this type of service. But the long hauls—the ones that require stiff mileage, speed and carrying capacity, are taken care of by gasoline wagons of various sizes.

When freight is unloaded from ships or railroad cars the loads are carried to the warehouses of such establishments by large sized gasoline cars. Of course there are some of the docks where the gasoline cars are still excluded on account of fanciful ideas about fire dangers, but in the main it may be said that such regulations are being worked out on a sane basis and the strictures will be eliminated in the course of time. The big trucks back up to the dock or freight yard and receive their loads. The cars are generally of three-ton capacity or larger.

The haul to the warehouses requires less time and the loads carried are proportionately larger than they could be with horse-drawn vehicles. Consequently there is an emphatic saving in this stage of the operation.

The effect quick transit has had upon retail business is strongly illustrated in the greater radius within which deliveries are now made without cost to the customer in comparison with conditions a few years ago.

For instance a big retail store will have one or more distributing depots located far beyond what were formerly the



J—A special point has been made by automobile truck sellers of the education of the users—note the care in loading this White

limits of the free district. In order to take care of this important phase of business the concerns load up big gasoline cars of three-tons capacity or more and make periodic trips from the main warehouses to the supply depots. In one case that was noted by a representative of THE AUTOMOBILE the supply depot was located fourteen miles from the warehouse and each evening the trucks are loaded and sent out with goods destined for delivery on the following day. The cars make the round trip of twenty-eight miles in three hours, transporting three tons of merchandise. Three trips a day could be made with a single truck and the labor represented would be the same as if eighteen horses drawing nine one-ton loads and taking the time of nine drivers had been used.

Twenty-eight miles in a day would be a big labor for a team and certainly the horses do not live that could make two such trips a day under load.



K—Packard trucks like this are constantly under careful scrutiny to see that they are kept at highest efficiency

At the depots the goods are unloaded and sorted for delivery throughout a wide territory and an appreciable amount of such delivery work is done with horse-drawn vehicles.

But another very important portion of delivery work is done by the medium-sized gasoline car. It is pioneer work and requires sturdiness of construction, speed and stability. This is the suburban delivery system. Light, bulky freight such as furniture is handled to a nicety in this way and small parcels, heavy and valuable freight also seems specially adaptable to this form of transportation. Forty, fifty, sixty miles a day are not unusual mileages for the automobiles assigned to this branch of the service. There is nothing easy about it and from the fact that there must be a long barren haul of the full load from the warehouse to the inside delivery limits and another long haul after deliveries have been made, make this kind of service peculiarly trying from the viewpoint of expense. Of course it would be economically impossible with horses as motive power and really represents the modern expansion of commercialism in its simplest form. Natural development of business might account for all the other elements of trade, but in the absence of branch stores, which have not proved perfectly satisfactory as a solution to the problem, the gasoline suburban delivery service has been the means through which the end has been accomplished.

Take a typical case to illustrate how inspection helps the owner to maintain his cars on the road: If an overloaded truck being driven at excessive speed is seen by an inspector, the facts are laid before the owner perhaps a month before the effects of such overload and excess of speed would make themselves apparent in putting the truck out of service.

If the motor acts abnormally or if any one of a dozen different faults are noted in the mechanism or if due care is not apparent in the operation of the truck, the facts properly reported may lead to saving a big repair bill and in keeping the truck on the road without a break for years.

Progress is to be noted in every branch of industry, but nowhere is it more apparent than in the commercial automobile. And now naturally follows the careful inspection of the cars so that this progress may be accentuated. So far the means of accomplishing this end have been vague, general and unorganized, but the trend of the times is all one way and development of the systems of inspection will undoubtedly form an important step in the perfection of the motor truck.

As has been shown, some of the companies have grasped the situation strongly and understandingly. The main object of the truck industry is not now to sell cars, but to sell cars that give service and consequently make a ready market for more cars as the exigencies of trade prepare a place for them to work.

The proof of the pudding lies in the eating thereof, and with the institution of adequate factory inspection after the cars have passed into the hands of purchasers, the universal use of the automobile truck does not seem so very far away.



Lozier, No. 12, Mulford driver, in a fast try-out

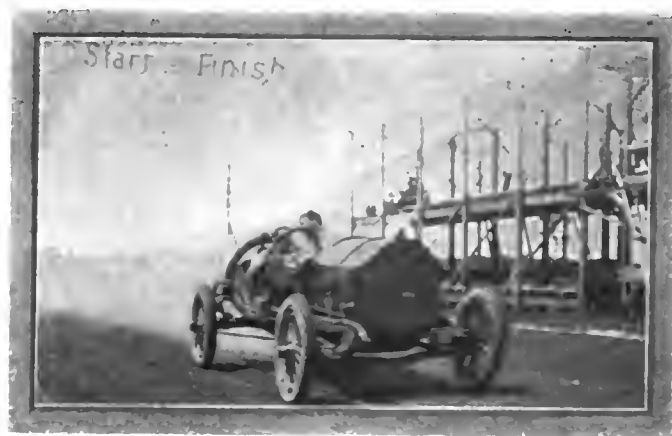

Cole, No. 25, with Jenkins at the wheel, going at a 65-mile clip

## All Eyes Turn Toward Elgin Course

### National Stock Car Championships to Be Run

*With an entry list of thirty-five, divided among the four big stock car races of the year which will be held over the improved course of Elgin, Ill., on Friday and Saturday, the indications point to fast time and sturdy performance in all the classes. Already one of the entered cars has turned the course at better than a 70-mile-an-hour-clip. Ireland, driver of a Staver, met death on Monday during practice.*

**C**HICAGO, Aug. 22—With a free field, as far as competition is concerned, the Elgin National Stock Chassis races, scheduled for Friday and Saturday, give promise of again proving to be the most important events in Western motordom. There will be four races, as was the case last year. The cars of the 301-450 class will run for the Illinois Cup at

202 miles on Friday, along with the other two divisions. The 231-300 class for the Kane County Cup at 169 miles, and the 161-230 class for the Aurora Cup at 135 miles. On Saturday the cars of under 600 cubic inches piston displacement will run for the famous Elgin National Trophy, a perpetual challenge cup, which last year was won by the Lozier (Mulford). The big race will



Scene at the tape when the majority of the contestants came out on the course for a series of practice speed trials

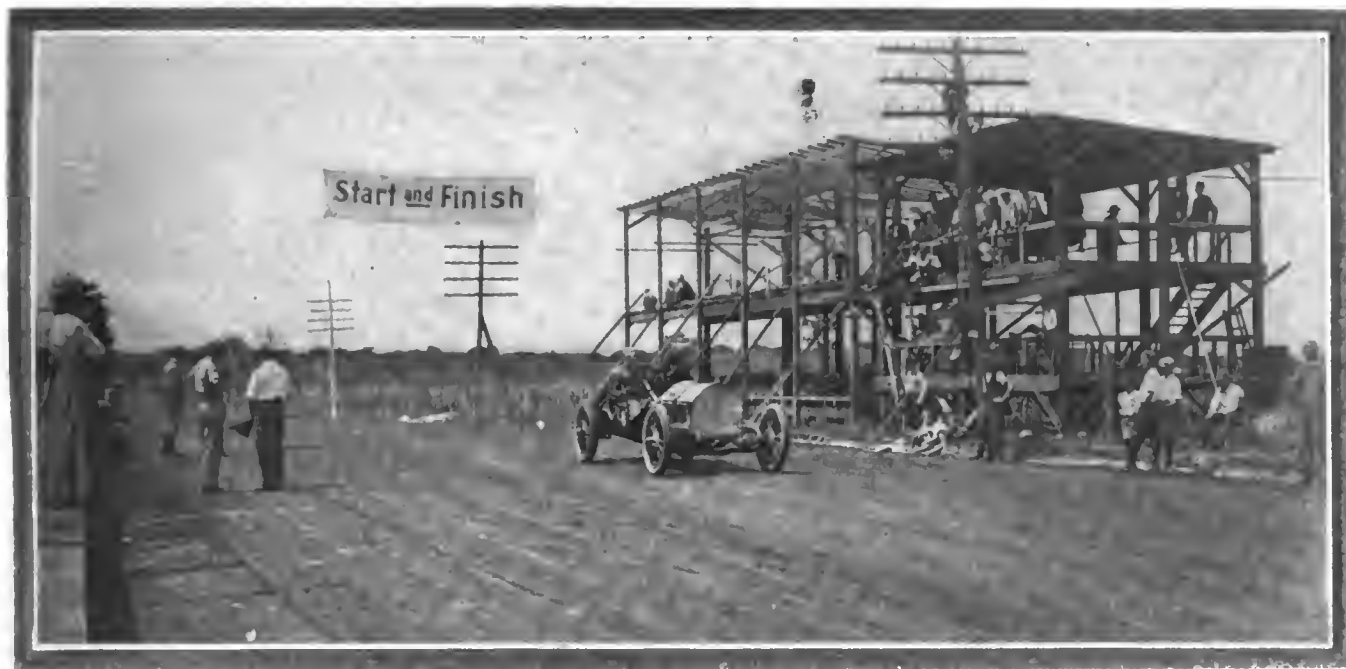

Showing the excellent condition of the track in front of the uncompleted press and timers' stands

be at 305 miles and will be the only event on Saturday. The closing of the entries Sunday night found thirty-five names in the box, one more than last year, with twelve in the Elgin National, four in the Illinois, sixteen in the Kane County, and only three in the Aurora.

These are a most representative lot, including fifteen makes—Lozier, Alco, National, Simplex, Pope-Hartford, Mercer, Velie, Staver-Chicago, Cole, Corbin, Colby, Cino, Falcar, Ford and Abbott-Detroit.

All of these are almost certain to go to the post with the exception of the Falcars.

All the turns have been widened, and the only possible criticism is found in a few thank-ye-ma'ams in the back stretch, which are no trouble when traveling at high speed. The home stretch almost is like a boulevard, especially that section between Hornbeck's Turn to Britten's Hill, just west of the grandstand, a one-mile strip which is 54 feet in width, extending from fence to fence and seemingly capable of 90 miles an hour.

Udina Turn now is 80 feet wide. The races will start at 11 o'clock each day, instead of at 10, as was the case last year, and the course will not be closed until 10.40 A. M., which ought to increase the attendance, for the main difficulty in the past has been to get the spectators seated in time.

Most of them dislike the idea of having to go out to Elgin the night before, and the idea of getting a start from Chicago at 5 A. M. is displeasing to the majority. Now, with all the transportation arrangements that have been made, it will be possible to leave this city as late as 8.30 o'clock and still get up to the course in time.

The military arrangements are complete, and for the third time Chicago will have use of the troops. At Crown Point two years ago, the Chicago Automobile Club accomplished the seeming impossibility of taking an Illinois regiment, the First, into Indiana. Last year the Chicago Motor Club had the Eighth Illinois at Elgin, while this year 200 men from the Third Illinois will guard the course the first day, while on the second day the First Illinois Cavalry, a Chicago troop, will be on the job, dismounted, of course.

Practice for the races started last Friday according to schedule. Grant, in the Alco, made the circuit in 8:02, at the rate of a little better than 60 miles an hour, and Aitken, in the National, swung around in 8:11.

On Saturday Mulford was clocked in 7:13, better than 70 miles an hour. His second lap was only 2 seconds slower. Aitken in the National was credited with 7:23 and 7:22; Meyers' best time was 7:36; Zengel, another National driver, did 7:35



Staver team in front of its quarters—Nikrent, 16; Robillard, 25; Monckmeier, 27

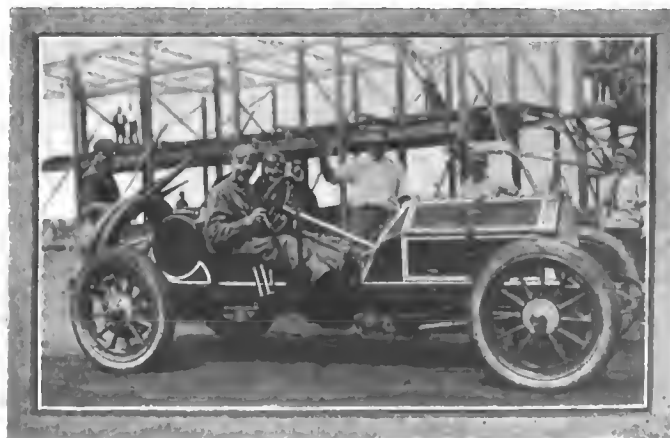

Mercer, No. 9, with Hughie Hughes in the driver's seat

and 7:56; Herr, the fourth man on the blue team, did 7:50 and 7:55; Hartman in the Alco turned 7:55 and 7:58, Grant did 7:42 and 7:47, while Hughes showed the pace of the Mercer by clocking 7:47 and 7:50.

On Monday Grant opened the throttle a bit for 7:43, while Wishart showed a bit of Simplex speed for the first time, being blocked in 7:41. His team mate, De Palma, was contented with a slower lap, his best time being 7:52; Aitken was recorded in 7:48, Hughes in 7:45, and Hartman in 7:43.

The following assignments of numbers have been made:

Elgin National: 1, Alco, Grant; 2, National, Zefigel; 3, Pope-Hartford, Buck; 4, Simplex, Wishart; 5, Alco, Lee; 6, National,

Aitken; 7, Alco, Hartman; 8, Cino, Raimsey; 9, Mercer, Hughes; 10, Cino, Burt; 11, Simplex, De Palma; 12, Lozier, Mulford;

Illinois Cup: 1, National, Herr; 2, Velie, Jeffkins; 3, National, Merz; 4, Velie, Stickney.

Kane County Cup: 11, Cino, Burt; 12, Mercer, Barnes; 14, Corbin, Maisonville; 15, Mercer, Hughes; 16, Staver-Chicago, Nikrent; 17, Falcar. —: 18, Colby, Ogren; 19, Falcar, —: 20, Colby, Pearce; 21, Cole, Morris; 22, Colby, Armstrong; 23, Falcar, —: 24, Cole, Jenkins; 25, Staver-Chicago, Rohillard; 26, Cino, Raimsey; 27, Staver-Chicago, Monckmeier.

Aurora Cup: 31, Abbott-Detroit, Robbins; 32, Ford, Kulick; 33, Abbott-Detroit, Roberts.

ELGIN NATIONAL TROPHY RACE, DISTANCE 305 MILES, FOR STOCK CHASSIS 600 CUBIC INCHES AND UNDER

Car.	Driver.	Model Year.	Number of Cylinders.	Bore.	Stroke.	Type of Cylinder.	Lubrication.	Pump.	Radiator.	Fan Drive.	Ignition.	Clutch.	Friction Surface.	Gearset.
Lozier	Ralph Mulford	1911	4	5 3/8	6	T	Mechanical	Centrifugal	Cellular	Spiral Gear Belt	Bosch two-point	Multiple Disk Cone	Steel and Steel	Selective A'dships
National	John Aitken	1911	4	5	5 1/2	T	Crankcase Circulating	Centrifugal	Cellular	Belt	Splitdorf two-point	Cone	Leather & Cork Ins't	Selective A'dships
National	Len Zengel	1911	4	5	5 1/2	T	Crankcase Circulating	Centrifugal	Cellular	Belt	Splitdorf two-point	Cone	Cork Insert	Selective A'dships
Alco	Harry Grant	1909	6	4 1/4	5 1/2	T	Crankcase Circulating	Centrifugal	Cellular	Belt	Single, Bosch	Multiple Disk	Steel and Bronze	Selective A'dships
Alco	Frank Lee	1911	6	4 3/4	5 1/2	T	Crankcase Circulating	Centrifugal	Cellular	Belt	Bosch two-point	Multiple Disk	Steel and Bronze	Selective A'dships
Alco	Harry Hartman	1911	6	4 3/4	5 1/2	T	Crankcase Circulating	Centrifugal	Cellular	Belt	Bosch two-point	Multiple Disk	Steel and Bronze	Selective A'dships
Simplex	Ralph DePalma	1912	4	5 1/4	5 3/4	T	Mechanical	Centrifugal	Cellular	Flywh'l	Bosch two-point	Multiple Disk	Steel and Steel	Selective A'dships
Simplex	Spencer Wishart	1912	4	5 1/4	5 3/4	T	Mechanical	Centrifugal	Cellular	Flywh'l	Bosch two-point	Multiple Disk	Steel and Steel	Selective A'dships
Pope-Hartford	Dave Buck	1911	4	4 3/4	5 1/2	{Over-head valves	Mechanical	Centrifugal	Hori. Tube	Belt	Splitdorf double	Disk Cone	Leather	Selective A'dships
Mercer	Hugh Hughes	1911	4	4 3/4	5	T	Crankcase Circulating	Centrifugal	Cellular	Belt	Bosch double	Multiple Disk	Steel and Steel	Selective A'dships
Cino	Andy Burt	1911	4	4 3/4	5	Valve in head	Mechanical	Centrifugal	Vert. Tube	Belt	Remy two-point	Disk Cone	Leather	Selective A'dships
Cino	John Raimsey	1911	4	4 3/4	5	Valve in head	Mechanical	Centrifugal	Vert. Tube	Belt	Remy two-point	Cone	Cork Insert	Selective A'dships

AURORA CUP, DISTANCE 135 MILES, FOR STOCK CHASSIS, 161-220 CLASS

Abbott-Detroit	Mortimer Roberts	1911	4	4	4 1/4	L	Crankcase Circulating	Centrifugal	Cellular	Belt		Multiple Disk	Steel and Steel	Selective A'dships
Abbott-Detroit	A. M. Robbins	1911	4	4	4 1/4	L	Crankcase Circulating	Centrifugal	Cellular	Belt		Multiple Disk	Steel and Steel	Selective A'dships
Ford	F. Kulick	1911	4	3 1/4	4	L	Crankcase Circulating	Thermo Siph.	Tubular	Belt	Ford Magneto	Multiple Disk	Steel and Steel	Planetary

ILLINOIS TROPHY, DISTANCE 202 MILES, FOR STOCK CHASSIS, 301-450 CUBIC INCHES

National	Charles Merz	1911	4	5	5 1/2	T	Crankcase Circulating	Centrifugal	Cellular	Belt	Splitdorf two-point	Cone	Leather & Cork Inser.	Selective A'dships
National	Don Herr	1911	4	5	5 1/2	T	Crankcase Circulating	Centrifugal	Cellular	Belt	Splitdorf two-point	Cone	Leather & Cork Inser	Selective A'dships
Velie	J. H. Stickney	1912	4	4 1/2	5 1/4	L	Crankcase Circulating	Centrifugal	Vert. Tube	Belt	Remy Dual	Multiple Disk	Steel and Steel	Selective A'dships
Velie	R. Jeffkins	1912	4	4 1/2	5 1/4	L	Crankcase Circulating	Centrifugal	Vert. Tube	Belt	Remy Dual	Multiple Disk	Steel and Steel	Selective A'dships

KANE COUNTY TROPHY, DISTANCE 169 MILES, STOCK CHASSIS, 231-300 CLASS

Staver-Chicago		1912	4	4 3/8	5	T	Automatic Splash	Centrifugal	Vert. Tube	Belt		Multiple Disk	Steel and Steel	Selective A'dships
Staver-Chicago		1912	4	4 3/8	5	T	Automatic Splash	Centrifugal	Vert. Tube	Belt		Multiple Disk	Steel and Steel	Selective A'dships
Staver-Chicago		1912	4	4 3/8	5	T	Automatic Splash	Centrifugal	Vert. Tube	Belt		Multiple Disk	Steel and Steel	Selective A'dships
Cole	J. Jenkins	1911	4	4 1/2	4 1/2	L	Splash	Centrifugal	Hon-comb	Belt		Cone	Leather & Cork Inset	Selective A'dships
Colc	Gaston Morris	1911	4	4 1/2	4 1/2	L	Splash	Centrifugal	Hon-comb	Belt		Cone	Leather & Cork Inset	Unit with motor
Corbin	A. Maisonville	1909												
Colby	W. H. Pearce	1912	4	4 3/4	5 1/4	L	Crankcase circulating	Centrifugal	Sq. tube	Belt		Cone	Therm. & Cork Inset	Selective A'dships
Colby	H. W. Ogren	1912	4	4 3/4	5 1/4	L	Crankcase circulating	Centrifugal	Sq. tube	Belt		Cone	Therm. & Cork Inset	Selective A'dships
Colby	A. Armstrong	1912	4	4 3/4	5 1/4	L	Crankcase circulating	Centrifugal	Sq. tube	Belt		Cone	Therm. & Cork Inset	Selective A'dships
Cino	John Raimsey	1911	4	4 3/8	5	Valve in head	Mechanical	Centrifugal	Vert. tube	Belt	Remy two-point	Cone	Leather & Cork Inset	Selective A'dships
Cino	Andy Burt	1911	4	4 3/8	5	Valve in head	Mechanical	Centrifugal	Vert. tube	Belt	Remy two-point	Cone	Leather & Cork Inset	Selective A'dships
Mercer	H. Hughes	1911	4	4 3/8	5	T	Crankcase Circulating	Centrifugal	Cellular	Belt	Bosch Double	Multiple Disk	Steel and Steel	Selective A'dships
Mercer	W. F. Barnes, Jr	1911	4	4 3/8	5	T	Crankcase Circulating	Centrifugal	Cellular	Belt	Bosch Double	Multiple Disk	Steel and Steel	Selective A'dships
Falcar	Speed type—not qualified													
Falcar														
Falcar														



# Problems of Steering Mechanism

## Analysis of Factors Governing Correct Design

*In this article, reprinted from the Motor Trader, A. Cattaneo discusses the problems which affect the steering mechanism of the automobile, with some notes especially referring to the correct placing of the tie-bar and to the power lost by want of parallel wheel tracking.*

FOR a theoretically correct steering it is imperative that the axes through the wheel spindles should radiate from a point situated on the back axle, as shown at D, in Fig. 1.

**FIRST ESSENTIAL FOR A PIVOT STEERING**—Fig. 1 shows this when the front wheels are moved from position I into position II. It has, however, been found that the practical fulfilment of this condition would require a prohibitive number of links or other complications, and a theoretically correct steering is, therefore, never met with.

The designer of the steering arrangement has, consequently, the following problem to solve. To connect in the simplest manner the front wheels in such a way as to obtain the greatest approach to the theoretical condition. Suffice it here to state that the quadrilateral style, either as an interior or exterior quadrilateral, is now universally used. The simplicity of this arrangement is one of its strongest points, and when carefully designed it may be made to fulfil all that is required of it as a substitute for unpractical devices. Unfortunately, however, its arrangement on many modern self-propelled vehicles points to the fact that the necessity for accuracy in laying out the quadrilateral is not fully appreciated, nor is its general design often sufficiently understood and considered.

**ACCURACY IN TRACKING**—In consequence of this inaccuracy the front wheels do not automatically adjust their angularity when negotiating a bend, but instead are compelled to slide over the road, with a corresponding detrimental effect on the life of the tires. There being more obvious factors responsible for the wear of the tires, the amount really attributable to the inaccuracy of the steering is liable to be underrated, if not overlooked altogether; and this, no doubt, accounts for the fact that hardly any improvement is attempted in the design of the steering connections.

On checking the accuracy of the steering of many cars it will be found that, by a very slight alteration of the quadrilateral, in almost every instance the degree of accuracy could be improved, and the life of the tires and the comfort in steering correspondingly increased.

**HOW THE QUADRILATERAL IS FOUND**—Fig. 1 shows that for an angle  $a$  of one of the front wheels, their corresponding axes intersect each other at a point D on the prolongation of the back axle. This only holds true for theoretically correct steering; practically such points as D will be located on a curve, enclosing with the back axle a surface which can be taken as a criterion for the accuracy of the steering, and of the extent to which this will tax the life of the front tires. Unfortunately, this method is of no practical value; the process of finding the axes of the wheels corresponding to a certain angle being a lengthy one; moreover, for a certain range of lock, the intersection of these axes would lie quite outside the drawing board, unless a very small scale be employed, and the accuracy of the result correspondingly impaired.

A little mathematical consideration will show how to evade this difficulty, besides giving a practical mean for comparing different results with each other and discussing them. Hence, referring to Fig. 1, let  $b$  equal the wheelbase, and  $2d$  equal the fixed distance between the pivots A and B. Suppose, however,

that the front wheels are moved from position I into position II, then carry the corresponding angle  $a$  of wheel A on the right-hand side of A; obtain, as shown, the point E on B D, and draw E G perpendicular to A B. Then the triangle A G E is similar to triangle A C D. By making the center F of the front axle the origin of a system of co-ordinates, it is:

$y : b = (d - x) : A C$      $A C = b (d - x) : y$   
triangle B G E is similar to triangle B C D; therefore:

$$y : b = (d + x) : (2d + A C), \text{ or}$$

$$y : b = (d + x) : [2d + b (d - x) : y].$$

After making the necessary operations we find

$$2 dy = 2 bx, \text{ or } y = (b : d) x,$$

which is the equation of a straight line L L going through the center F of the front axle, and making with it an angle  $e$ ; so that  $\tan e = b : d$ .

It is obvious that this relation holds true for any value of the angles  $a$  and  $c$ ; therefore, the line L L contains all the points obtained in the same manner as point E. This, again, is only theoretically correct; practically such points as E lie on a curve, including with L L a surface which can again be taken as a criterion of the accuracy of the arrangement of the quadrilateral.

**AN ERROR IN STANDARDIZATION**—The diagram shows also in an obvious manner that the very common practice of using a standard steering arrangement for different types of car, although very convenient for the manufacturer, should be departed from on account of the increased inaccuracy involved.

For illustration of this it is sufficient to refer to Fig. 2. If curve 1 corresponds to the best results obtainable with a certain quadrilateral on a 11-ft. wheelbase car, by reducing this length to 9 ft. the angle  $e$  is also correspondingly reduced; that is, line L L moves farther away from the curve which, of course, by retaining the old quadrilateral remains the same, and the increased surface lying between the new line L L and the curve shows to which extent the accuracy of the steering has been reduced.

Again, suppose the front axle and the wheelbase to be given. The first one only needs to be shown in the drawing. Through its center draw a line L L under an angle  $e$ , so that

$$\tan e = b : d.$$

Assume a certain quadrilateral, *e. g.*, that marked 1; move one of the wheels (for sake of argument, A) at different angles to the left, one of these being angle  $a$ ; carry this angle inside by drawing the line A Q; find the position S of the lever  $r$ , and by means of the tie rod  $l$  determine the corresponding angle  $c$  of wheel B. Produce the axis of this new position of wheel B until it intersects the line A Q at a point P. This process applied to a few different angles will supply as many points; by joining which a curve—such as the one marked 1—is obtained, approaching more or less to line L L, according to the accuracy obtainable with the quadrilateral in question. It is, of course, only necessary to obtain one branch of the curve; for instance, the one lying inside the front axle, and corresponding to a movement to the left, as for an equal lock to the right the curve is symmetrical to both the front axle and line L L.

**A PRACTICAL DEDUCTION**—The advantages of this method are

too obvious to require comment. The arrangement can be sketched out almost to full size, and, therefore, very accurately. By slightly varying either the length or the angularity of the steering levers  $r$ , a quadrilateral can easily be found giving the greatest accuracy obtainable.

Again, by comparing curve 4 with curve 1, it will be noticed at once that quadrilateral 4 gives greater accuracy than quadrilateral 1; the latter being obtained in the usual manner by setting the lever arms  $r$  at such an angle that they intersect on the center of the back axle. This method of laying out the quadrilateral should, therefore, be discarded, and both steering arms be made to intersect in front of the back axle and at a distance from it about equal to the fixed distance between the pivots of the steering wheels.

The correct position of the point of intersection cannot be given, as the ratio of wheelbase to length of front axle is not constant; but by assuming different positions for the point of intersection of the steering levers, and by plotting the corresponding curves, it will be an easy task to see which arrangement gives the best results. The diagram will also throw light on the important question whether an interior or an exterior quadrilateral should be adopted. The latter arrangement is gaining favor among the leading makers, and, were its advantages fully understood, one would wonder why the interior quadrilateral is still adhered to.

**CORRECT POSITION OF TIE-BAR**—By comparing curve 1 with curve 2 (Fig. 2) it will be seen that with the same length and angularity of the steering levers the "in-front" disposition gives not only mechanical advantages, but also a markedly greater accuracy, due to the increased length of the tie-rod. It can easily be proved that for a given interior quadrilateral an exterior one can be found to realize better the theoretical condition for correct steering. There are other points that speak in favor of the "in-front" arrangement; so many, in fact, as to totally outweigh whatever reason may be urged in favor of the rear placing.

The advantage of having the tie-rod under tension is not a trivial one. The strength of the material is better made use of; but the rod should not on this account be reduced in weight, as the peculiar conditions under which it transmits power from the steering wheel require—in the case of an exterior quadrilateral—a larger section for the tie-bar than is permissible with the interior one. This is readily accounted for by bearing in mind that the coupling bar is to be considered as a connecting rod in which buckling stresses are set up, and, therefore, the

strength of its section diminishes inversely with the square of its length. But even in this respect the "in-front" position scores. It permits a strong, straight bar to be used, whereas with the interior quadrilateral the middle part of the tie-rod, which is, unfortunately, also the dangerous section, is very often to be found bent, or cranked, to clear the engine basechamber, or some other part, with an obvious detrimental effect on the strength of the arrangement.

The "in-front" position of the tie-bar facilitates, to a great extent, the erecting of the steering connections, and is surely the best from the point of view of upkeep, for it allows the joints to be easily inspected and their lubrication to be properly attended to, and also permits the tie-rod itself to be easily removed and repaired.

By the opposed or rear position of the tie-rod and steering arms it is claimed both are protected, so that the steering would not be disabled in case of a collision. This sounds quite reasonable, and it is as a matter of fact the only good point in connection with the interior quadrilateral.

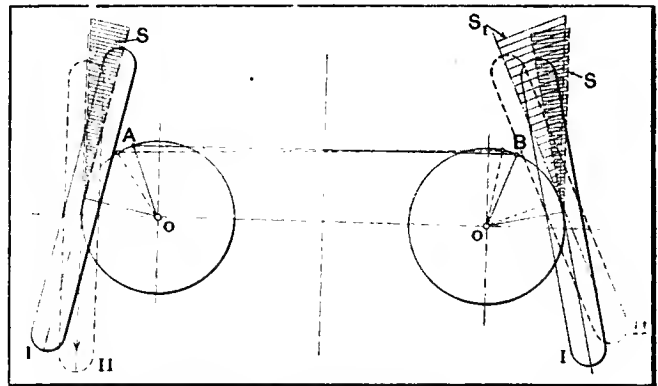

Fig. 4—Illustrating compromise setting for a racing car

Here it may be opportunely remarked that, by placing the tie-rod in front, it can also be moved farther away from the ground than is the case with the interior arrangement, and any accident that would then affect the tie-bar would most probably also injure some other part, if not disable the car.

It is also claimed for the rear placing of the tie-rod that the absence of links and levers enhances the good appearance of a car, when viewed from the front. It is undoubtedly better in many instances, whether for esthetic or other reasons, if the front axle be made to screen some of the fancy shapes of the crooked tie-rod one sees, but, on the other hand, the critic will fail to see how the elegant and graceful lines of a modern chassis could be spoiled by a neat and straight rod placed symmetrically both to the front axle and frame.

Finally, it is also urged against the exterior quadrilateral that, by its adoption, the ends of the steering levers may come dangerously near the spokes of the wheels. This point should not be overlooked by the designer, and before definitely adopting a quadrilateral he should make himself sure that it gives the greatest accuracy with a reasonable amount of clearance between the spokes and the ends of the steering arms, for each angle of the front wheels, within the range of lock.

**ANGULARITY IN STEERING WHEELS SETTING**—For another species of practice retained by a few designers a plausible explanation still obtains. I refer to the practice of setting the steering wheels out of parallel, so that they converge at a point in front and on the axis of the car. The angularity is very small, the angle included by both wheels being no more than from five to seven degrees; and this undoubtedly accounts for this practice remaining often unnoticed or undetected.

The modern motor vehicle is admittedly designed on compromises. Some of these nearly give ideal conditions, while others would barely stand a close investigation. Regarded from this standpoint, it will serve to examine the behavior of both systems

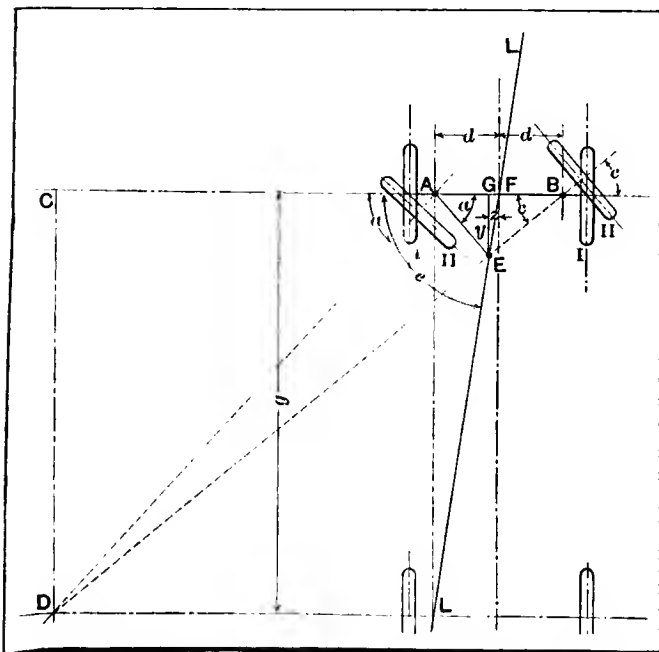

Fig. 1—Illustrating the theory of a correct steering design

of setting the steering wheels, and with a view to ascertain whether it would not be possible to arrive at a compromise which would embrace the advantages of both systems, and reduce, if not eliminate, their respective drawbacks.

**PARALLEL VS. ANGULAR SETTING ANALYZED**—Referring to Fig. 3, both wheels, which are parallel, are shown with the quadrilateral  $O A B O$  in the neutral position I, while the car itself is supposed to be traveling in the direction of the arrow, overcoming a certain resistance  $R$  acting in the axis of the vehicle and equally distributed between the two wheels. These two forces, however slight they may be, being transmitted through spindle and lever to the tie-rod, and the two components lying in its direction, are obviously neutralized.

Let us now suppose that the wheels be moved from position I into position II, and the same resistance  $R$  be acting again in the axis of the vehicle—both these forces  $R$  are supposed equal, the angles to which the wheels are locked being taken very small; they, therefore, need not be specially inquired into, and can be represented by the length  $R$ .

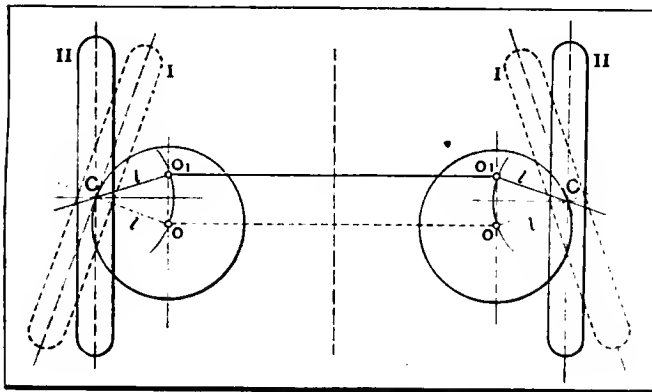

Fig. 5—Illustrating a theoretically correct setting

It is easy to resolve this force into two components, one of them in the direction of the wheel axle, and taken up by the steering pivot, and the other at right angles to the first. If, for the sake of simplicity, the wheels are supposed not to be splayed, and, moreover, the distance between center of wheel and center of pivot be equal, the length of steering arm (the component of  $R$  at right angles to the spindle) will be found again at the end of the steering arm and perpendicular to it. Here this component is resolved into two others; one in the direction of the steering arm, and taken up by the pivot, the other lying in the direction of the tie bar, tending to pull this over the left. Let this component be called  $P$ .

For the steering to be in a condition of equilibrium, it is obviously imperative that this force  $P$  be destroyed by another equal force acting also on the tie-bar, but in the opposite direction. By applying the procedure just described to the other wheel, whose position is determined through the assumed quadrilateral, it will be found that not only is the corresponding component force  $P_1$ , in the tie rod, different from  $P$ , but, and this is the serious point, it is also to a markedly smaller amount. In this connection it should be pointed out that for the purpose of showing better this peculiar behavior, the quadrilateral has an exaggerated angularity, and the angles of lock shown could only be obtained with a considerable movement of the steering wheel. Nevertheless, the diagram shows that the arrangement is not in a state of stable equilibrium.

**WHY WHEEL WOBBLING OCCURS**—With an accurate quadrilateral, smaller lock and sufficient splay of the wheels, the difference  $P, P_1$  will certainly be reduced, but without it being possible to entirely eliminate it. As has already been pointed out, the peculiarity lies in the fact that, unfortunately,  $P$  is always greater than  $P_1$ ; or, in other words, when the wheels are moved a certain angle a tendency is also created to automatically

increase the initial lock. This was very apparent with the earlier cars.

The advent of irreversible steering gear was a step in the right direction, but did not affect this tendency by which the wobbling of the wheels, and not a few so-called mysterious accidents, can easily be explained. If, when riding over rough roads, or in meeting an obstacle, the impact be strong enough to cause the particular wheel to assume a certain angle (the play at the joints and the springs interposed in the steering connection will always allow a wheel to give a bit), the resistance then creates a tendency to follow up the lock, and this will really follow until the buffer spring at the ball joint of the steering arm is fully compressed. Hence, if then, for some reason or other, the resistance diminishes, the fully compressed spring "shoots" both front wheels back in the neutral position, and, perhaps, over it, and the process is ready to begin again. If such resistance be not reduced the driver will be called upon to rectify the angularity of the wheels.

**Defective Tracking Causes Large Power Loss.**

In measuring the tractive efficiency of a motor car no account is taken of any formula of the power absorbed by the front wheels, these being taken as running parallel, i.e., tracking correctly. If, however, this condition be not fulfilled, there will be a large additional loss; the efficiency might be as high as could be desired, and yet, under otherwise the same conditions, the behavior of the car on the road would make but a poor show as compared to the one of another car of lower efficiency and faultless setting of the front wheels. In the case of a 40 brake-horsepower car without having met with an accident necessitating the fitting of new front wheels, it was found that the highest speed obtainable had fallen from 50 to 42 miles an hour. The engine had been untouched, and the transmission turned as smoothly as before.

When, however, the front wheels were tested for parallelism they were found to be "out" by 4 degrees. At first, so apparently small an error was considered too trivial to be reckoned a possible cause, but on plotting the deviation graphically it was found that at 2 degrees from being parallel 3 horsepower was absorbed, increased to 6 horsepower at 4 degrees and 9 horsepower at 6 degrees on each plotting at 50 miles an hour with a pro rata scale for the lower speeds. The moral, therefore, is obvious.

**A RACING CAR COMPROMISE**—A solution of the angularity dif-

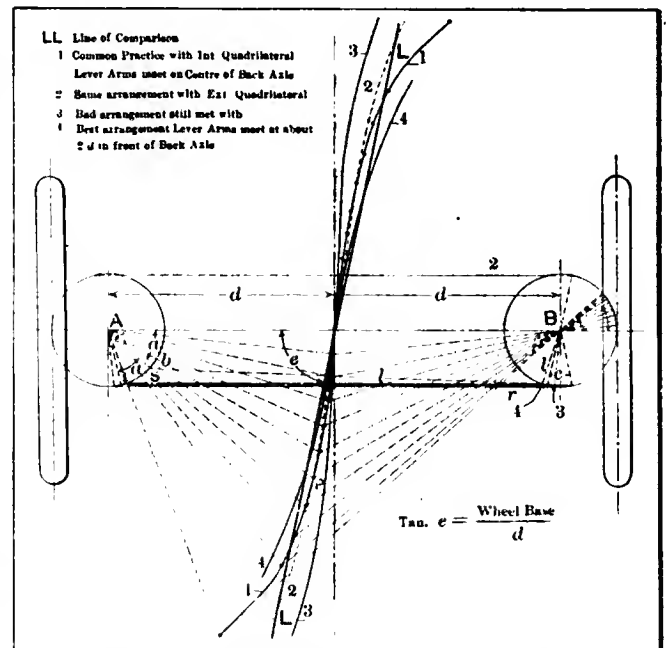

Fig. 2—Comparative graphs of types of steering design

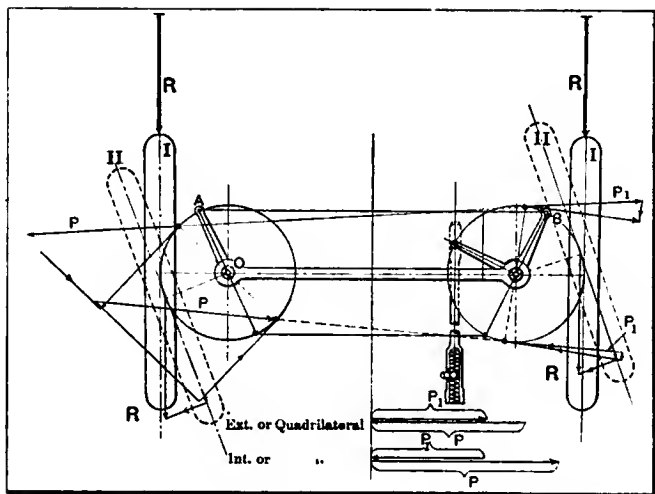

Fig. 3—Illustrating parallel vs. angular wheel setting

difficulty as it concerns racing cars is shown in Fig. 4. It will readily be seen that, owing to the wheels being not parallel their motion is of a mixed rolling and sliding character. When driving straight along with the wheels in the neutral position, the amount of work corresponding to the sliding motion is obviously equal for both wheels, being mainly dependent upon the angle they enclose. It can, therefore, be assumed proportional to the surfaces  $S, S$ . If the wheels be moved from position I into position II, the work  $S$  of the "leading wheel" is reduced from  $S$  to zero, while for the other it increases from  $S$  to  $S_1$ , that is to say, for a certain lock the off-side wheel has to overcome a much greater resistance; it opposes, therefore, to an increase of the angularity, and tends to bring back the wheels to their neutral position. This steering is positively stable; a shock which would produce a certain lock at one wheel has also to overcome the increased work of friction of the other wheel; that is, the force of impact will never produce any considerable angle at one wheel, and even if that could happen the steering would at once right itself. A car, when going at a good speed, would always keep its direction, even in case the steering arrangement should become valueless.

**A DRAWBACK AND A DEDUCTION.**—As it has been pointed out before, this setting has the great drawback of taxing the life of the tires to an almost alarming extent, on account of the sliding motion to which the wheels are subjected. Moreover, their angle being small, unless great care is taken in erecting, the angularity will probably not result the same for both wheels, which means increased wear of tires and instability of steering. Some makers use for the setting a kind of jig with correspondingly more accurate results. It would seem, therefore, that the correct setting of the steering wheels should combine the true rolling motion of the parallel system with the stability of the converging arrangement.

**AN EFFECTIVE COMPROMISE.**—Referring to Fig. 5, it will be seen that this condition may be easily attained. Let  $C O O C$  represent a front axle corresponding to the neutral position I of the wheels; these latter converging at a point in front of the car. If the distance  $C C$  and the length of the steering lever are constant, and both wheels are made to turn about the points  $C C$  as their respective centers, the points  $O$  will have to move to  $O_1$ , and a new position  $C O_1 O_1 C$  for the front axle is obtained. This not only allows for the wheels to run parallel, but has also the stability of the converging arrangement.

Recently some makers, appreciating the advantages of the setting shown in Fig. 5, have accordingly modified the front axle of their new cars by adopting the form shown in Fig. 6. It is easy to prove graphically that this setting of the steering wheels is as stable as that shown in Fig. 4. To carry out this, the same procedure may be applied as was done for the arrangement shown in Fig. 3.

It will be found that for no matter at whatever lock to the left, the force  $P_1$  is always greater than  $P$ ; that is to say, there is a tendency for the wheels to return in their neutral position whenever, for some reason or other, they have deviated from it. The common practice of splaying the wheels reduces the strains in the pivot, may even eliminate them altogether under certain circumstances; but as the length of the steering levers is usually greater than the distance between the center of the wheel and the pivot, the stresses in the tie rod are almost always present.

**ANOTHER FACTOR IN WHEEL WOBBLING.**—The circumstance that wobbling is apparent to a greater or lesser degree on different cars points conclusively to the fact that, while unable to entirely avoid the causes of the unsightly occurrence, some careful designers have, however, succeeded in reducing to a minimum the unsteadiness of the front wheels, improving thereby not only the appearance and the running of the vehicle, but also the wear and life of the tires and steering connections. The remedy is so simple and obvious that no doubt it would be generally adopted, were the designers of motor cars only to give this point the proper amount of thought and consideration, bearing in mind that not only ought the steering to be made a mechanical and accurate job, but also that its connections should be so contrived as to minimize whatever disturbance may arise through the floating suspension of the front axle. The neglect on the part of designers to take these disturbances into consideration when laying out a steering arrangement is certainly a fruitful cause of the wobbling of the front wheels, as will be clearly shown by even a superficial examination of Fig. 7. This diagram represents the generally adopted method of front axle suspension, by which the front end of the spring is hinged at a fixed pivot on the frame, while the rear end is suitably shackled, so as to permit the elongation of the spring to take place only in a rearward direction. If, now, the riding over an obstacle causes the spring to be deflected from form I, say, into form II, the front axle will no more remain in the same vertical plane, but will obviously follow the movement of the spring to which it is rigidly attached.

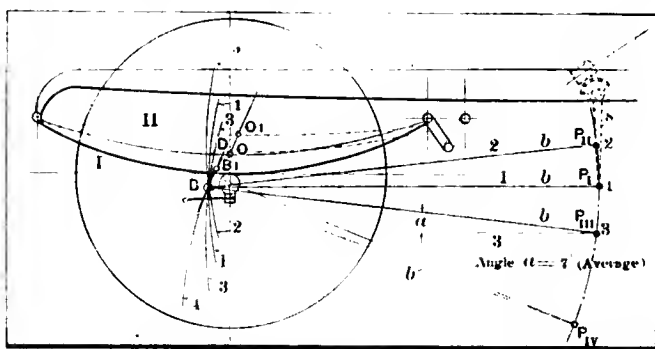

Fig. 7—Illustrating imperfect design as a cause of wobbling steering wheels

The path of this movement will be a certain curve, dependent upon the vertical displacement of the wheel, and upon the corresponding deflection, that is, elongation, of the spring. Let  $O$  be the center of the spring when in the neutral position, I, and  $O_1$  that corresponding to position II; then  $O$  and  $O_1$  are obviously two points of the curve referred to. For the sake of simplicity suppose these points  $O$  and  $O_1$  to be connected through a straight line, which, instead of the theoretical curve, is now taken to represent the path along which the centre  $O$  of the spring moves, when this latter has been deflected to a corresponding amount.

The front axle evidently partakes of the same movement; and so would the spherical knob  $B$ —supposing the rod  $b$  to be removed—displacing itself along a straight line  $BD$ , parallel to  $OO_1$ . If the steering arrangement marked I is considered, it will be readily seen that on account of the immobility of point  $P_1$  the only possible movement of the ball  $B$  is along a circle  $i$ , struck from  $P_1$ , with  $b$  as radius, and passing through the centre

of B; in other words, the steering knob B alters its relative position to the front axle to an amount represented by the surface enclosed between the arc of circle I and line BD. It is obvious that this displacement causes the wheel to be moved sideways to an amount corresponding to the shaded surface enclosed by the theoretical and actual parts of ball B. When the spring returns to its neutral position the reverse proceeding takes place, and the wheels are automatically set straight again.

**EFFECT OF FRONT SPRING DEFLECTION ON THE STEERING GEAR—**It is easily conceivable that if a vehicle is too lightly sprung the riding over an ordinary road will cause the springs to be in an almost perpetual state of oscillation, resulting, as has been shown, in wobbling of the front wheels.

The buffer springs, interposed at the point P<sub>1</sub> between the steering arm a and the connecting bar b, may under circumstances permit the latter to "go back" a small amount, with the consequence that the ball joint B will no more describe the circle I, but moves instead along a new curve, lying between circle I and line BD, and approaching more or less to this last-named, according to the stiffness of the cushioning springs referred to. The purpose these buffers are intended to serve requires them to be fairly strong; it seems, therefore, that the best solution of the difficulty would be to find such a position for the point P<sub>1</sub> that the circle struck from it as centre, and with b as radius, would practically coincide with the theoretical line BD. It is fairly obvious that this condition will be fulfilled if the point P<sub>1</sub> lies on a line drawn normally to the centre of the path, as shown for point P<sub>4</sub>.

In this connection it is interesting to point out that some makers, by adopting for the connecting bar the disposition marked 2 (Fig. 8) not only seem to forget the requirements of a correct steering, but also to be positively striving to increase an unfortunately unavoidable inaccuracy. As it can be readily seen in the diagram, the higher point P II is in relation to B the greater will be the discrepancy between the theoretical and actual paths of the knob B, and the greater, therefore, the tendency to wobble in the front wheels. The point P<sub>4</sub>, obtained in the manner shown

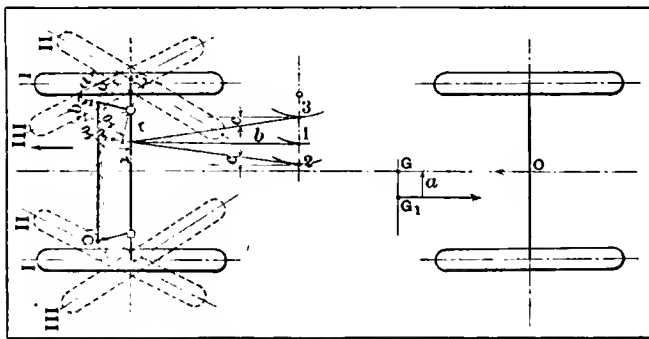

Fig. 8—Illustrating the effect of a faulty distribution of weight

in Fig. 7, is the only position for the lower end of the steering arm a, for which the discrepancy referred to can be neglected.

To avoid wobbling it is, therefore, imperative that point P III should approach P IV, as close as practically possible, a condition which can be translated into practice only by placing the connecting bar at an angle, raising towards the front of the vehicle, as it is shown for the arrangement marked 3. The increased length of the steering arm a that would result from this disposition can easily be obviated by placing the ball joint B above the front axle. The angle included by the connecting bar b and the horizontal axis varies on different cars, but an average value of 7 degrees has given satisfactory results.

**EFFECT OF FAULTY WEIGHT DISTRIBUTION—**Fig. 8 shows also how a faulty distribution of weight may, under circumstances, give rise, if not actually to wobbling, at least to some disturbances in the steering of the car. As a vehicle moves along, overcoming its own inertia, this latter can be rightly considered as a force T applied at the centre of gravity G of the vehicle, and

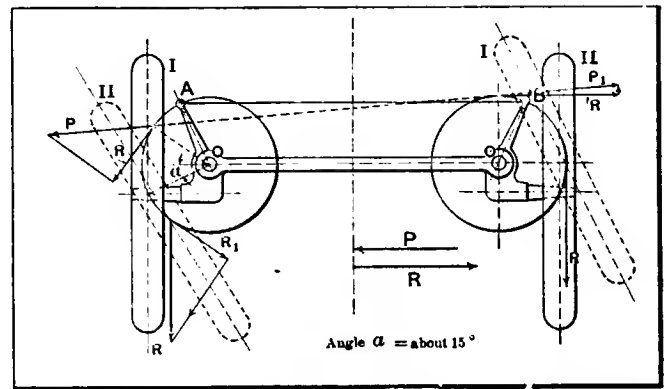

Fig. 6—Illustrating a modification of the type shown in Fig. 8

acting in the opposite direction to that in which the car is moving. It will be seen that if care is not taken to equally distribute the weight, the center of gravity will be no more on the axis of the vehicle, but on one side of it, at a certain distance a. At this new centre of gravity G<sub>1</sub> the force of inertia is now applied, while the power is still acting at the two back wheels, or which amounts to the same, at the point O. A couple whose lever arm is a is thus produced, tending to pivot the whole car round its hind wheels; the front wheels will therefore be inclined to slide to the left, resisting power against this tendency through their friction to the ground.

As soon as the engine is declutched the force of inertia instantaneously reverses its direction, and the front wheels are now inclined to slide to the right. It is easily conceivable that thus a tendency may arise to make both front wheels strike to the right and to the left, which tendency, by bad workmanship and undue amount of play and wear, may also result in wobbling of the front wheels.

**ACCURATE REGISTERING OF WHEEL LOCK.—**Another very important condition that every well-designed steering should fulfil is that the steering wheel should be turned to the same angle for an equal lock to the right and to the left of the steering wheels.

Referring to Fig. 8 again, it will be seen that for the neutral position I of the steering wheels, the corresponding position of the quadrilateral is O<sub>1</sub> O<sub>1</sub> A<sub>1</sub>. For a lock III to the left, the steering lever A moves a certain amount corresponding to an angle b, while for exactly the same lock II to the right, the angle to which A will have to move is undoubtedly greater, and in our case equals a. It is assumed, as required by the condition mentioned before, that for both locks the point I of the steering arm displaces itself the same amount to the right and to the left, its extreme positions being therefore symmetrically placed in relation to the axis of the steering arm when in neutral position. The point A of the connecting bar b and steering lever must, however, make such a movement as to correspond to an angle b in one case and a in the other. It is therefore apparent that the situation of the point A requires careful consideration, although it is a very easy matter to determine graphically the exact position of it. It will be found that if the connecting bar b can be disposed parallel to the axis of the car good results are obtained by placing the lever A at right angles to the steering lever of the quadrilateral; in case the point A of the steering lever is assumed in between the central axis of the vehicle and the point I of the steering arm, the angle included by A and the lever of the quadrilateral should be taken equal 90 deg. less angle a, made by the connecting bar with the center line of the car; if, on the contrary, the point A is situated on the other side of the steering arm, the angle between the two levers above referred to ought to be equal to 90 degrees plus the said angle a.

**BALL JOINTS.—**It may be said with a full degree of assurance that the steering is such an important function of an automobile that in its failure, the most serious danger lies. The possibility of a ball-socket joint becoming detached should be provided against in a mechanical and absolutely dependable way.



# Valveless Motor Research

## Conservative Makers on Lookout for Novelties

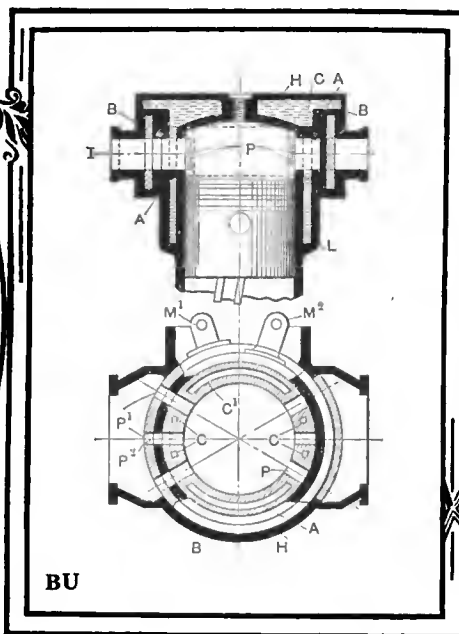
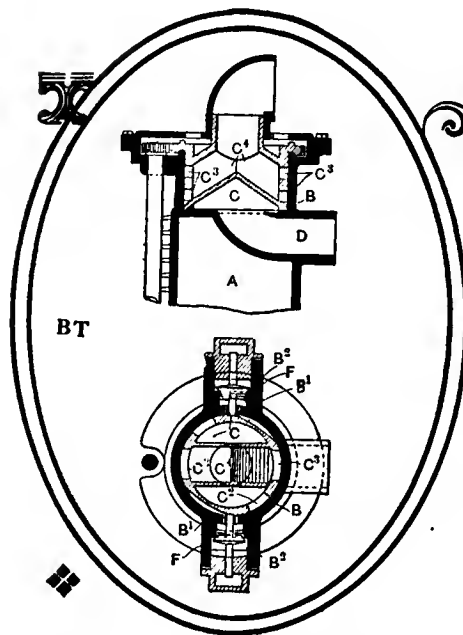

interstices of the metal, thereby eliminating wear. One has only to look at one of these motors after it has been taken down, to be convinced of this fact.

### Clifton Motor Utilizes Rotary Valve in Shape of Cam

The mechanism of the rotary valve of a Clifton motor consists of a combination of a cylindrical valve casing B in the cylinder head and an induction passage D leading into the base of the casing, one or more ports B1 in its cylindrical wall connecting to the cylinder A. The rotary valve C fits into the casing B, the valve being opened at the bottom so that its interior is in communication with the induction passage D having one or more inlet ports C2. One or more ports B1 are provided in the wall of the casing B and the passages B2 connect the ports to the cylinder A. The rotary valve has inlet ports C2 leading from its interior which is in communication with the induction passage D, and exhaust port

Fig. BT—Showing two sectional views of the Clifton motor together with the rotary valve

Fig. BU—Plan and transverse sections of the Hay rotary sleeve valve motor

Fig. BV—Method adopted by Samain in operating the double sleeves for controlling the gases

Fig. BW—Section through the Minerva-Knight motor showing the shape of the ports

*Among the motors here shown is a description of one patented by the Renault Company in France, which, up to the present, has not been incorporated in any of the firm's standard models. Such being the case it must be a warning to inventors that they must not expect that all they have to do is to invent a motor and then cash in.*

**T**HERE are certain problems involved in the valveless motor that need more than a dash of the pen to explain or criticise. Familiarity with the practice in vogue in the conventional poppet valve motor will require supplementing in order that the engineer shall be in a position to take the new situation in hand seriously. What was good in the above-mentioned types may prove an utter failure in a valveless motor. There seems to be an idea in some people's minds that the sleeves of some of the commercialized propositions will wear unduly and thus allow the compression to leak.

As far as experience goes this has not been the case and instead of deteriorating

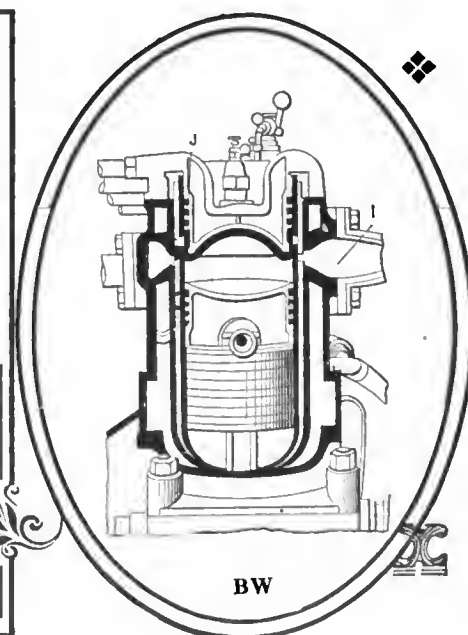
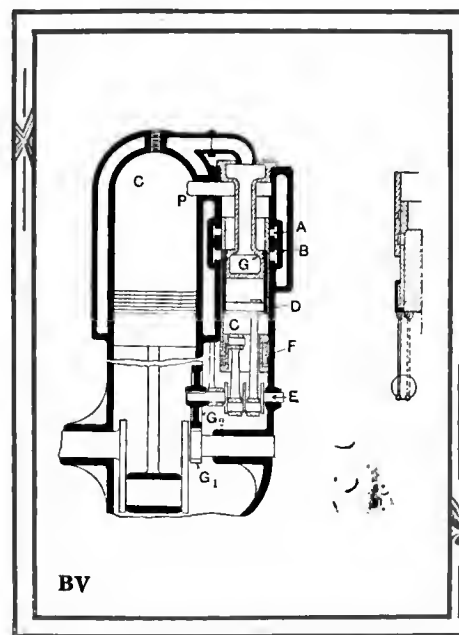

motors have shown a tendency to improve. When the length of the sleeves and the large film of oil that surrounds them are considered it must be clear to most people that the gases will follow the line of least resistance, which is out of the ports provided, rather than endeavor to pass between the sleeves. Another point to be remembered is that the carbon generated in the motor acts as a lubricant and fills up the

C3 is connected to an outlet in the top of the valve by the passage C4. The ports B1 in the casing B are controlled by an auxiliary lift valve F situated in the passageway B2, in addition to the rotary valve C. An auxiliary valve F is also provided, directly actuated by a cam on and controlling the same port as the rotary valve C. The method of operating this type of valve is shown in Fig. BT.

### Hay Motor Employs Two Concentric Rotary Sleeve Valves

In Fig. BU can be seen the method employed by J. Hay of controlling the ports of a four-cycle motor by means of two sleeves. The cover H which encloses the valves is provided with water cooling in the manner shown and the water space in the head is connected to L by means of a channel. Both sides of the valves A and B have cut in them ports P1 and P2 on the inlet side I. Where the ports are in multiple the port sleeves have passages in them at C, which are necessarily smaller but serve to maintain the valves and other parts at an even temperature. The valves are operated from the crankshaft through suitable gearing through the medium of the half-speed shaft. The arms M1 and M2 are attached to the sleeves B and A respectively.

### Principles Governing the Gaubert Sleeve Motor

The section of the motor in Fig. CB, the patent for which has been registered by Marcel Jules Marius Gaubert, shows the manner in which a single sleeve operates the ports on a motor of the four-cycle type. Attached to the crankshaft are cylindrical members C with helicoidal grooves cut therein in which pins attached to the ends of the lever H are fitted. The rotation of the cylinder C causes the lever to be displaced laterally, which action causes the

terposed between the piston and the cylinder wall. The illustration affords an idea of the method employed by this firm of carrying out such features as motor cooling, the position of spark plugs and in particular the throats of the passageways for the exhaust and intake gases. The inlet passageway I is enlarged at the point where the manifold is attached to the cylinders and narrows down in order to conform approximately to the size of the

the conventional type of valve as compared with valveless motors of the Knight type. The appreciable gain in power in the valveless motor over the other type is more noticeable as the speed increases, which may be due to the fact that motors of this type have very little compression at low speeds, which, however, materially increases with the corresponding increase of the motor speed. In the 16-horsepower type shown at B in the diagram it will be noticed

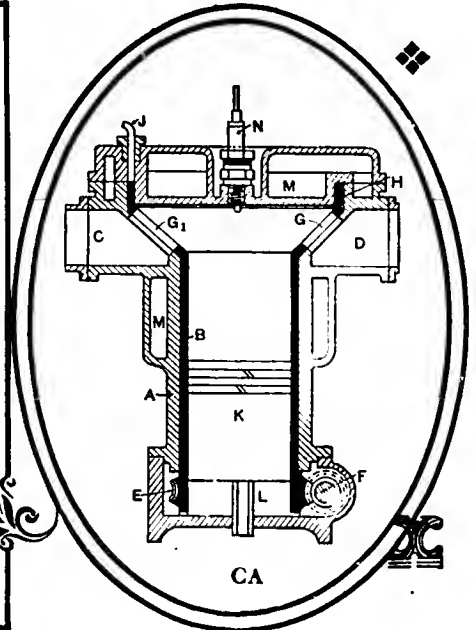
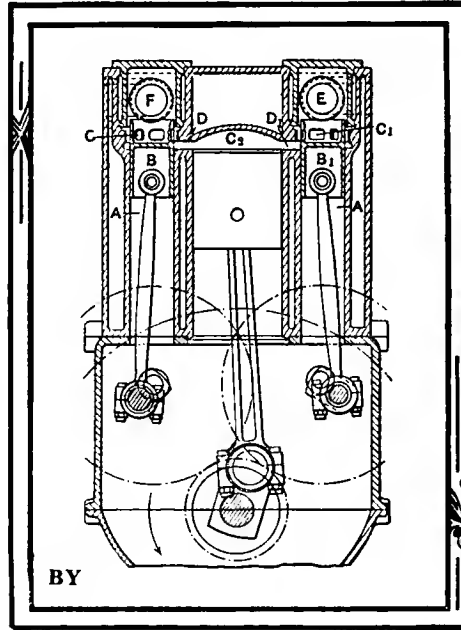
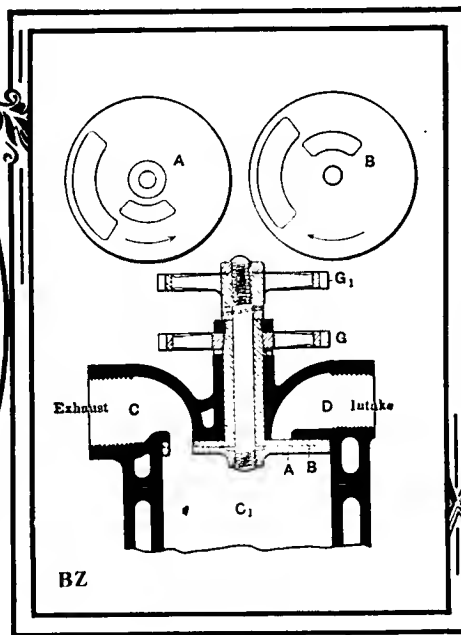
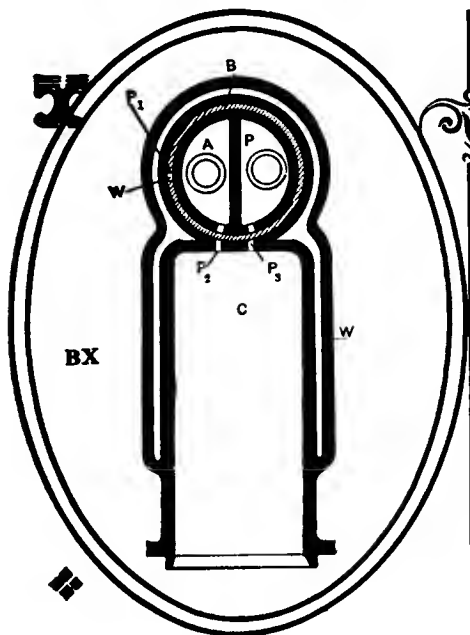

Fig. BX—Section through the Harper motor, in which two sleeves are employed

Fig. BY—The Albion motor, in which piston valves replace the conventional poppet valves

Fig. BZ—Method of operating the disc valves in the Rowell and showing the port openings

Fig. CA—Section through a cylinder of the Renault rotary sleeve valve motor



that the size of the motor is 3 millimeters less in bore than the motor, the curve of which is shown at A.

Again looking at the curve E at 1,500 revolutions there is a difference of 13 horsepower at this point, whereas at the 800 revolutions per minute of the engine point of intersection there is only a difference of 9 horsepower.

### Harper Motor Employs Stationary and Rotary Sleeves

It is possible from the sectional view of the motor shown in BX to see the method by which the regulation of the gases is effected. The cylinder C is water-jacketed at W and W1, the upper portion W1 being in direct communication with W. Two concentric sleeves are situated in the cylinder head and extend the whole length of the cylinders which are necessarily cast en bloc. The inner sleeve A is divided along its entire length by the partition P which makes it possible to utilize it both for the intake and exhaust gases. This sleeve A is stationary, while the sleeve B through suitable mechanism is caused to rotate and

sleeves to be drawn down or pushed up as shown on the right-hand side of the section CB.

### Minerva Motor Built Under Knight License

The Minerva motor, a section of which is shown in Fig. BW, is built under the Knight patents and has, as can be seen from the illustration, two concentric sleeves in-

slot in the sleeve. The junk ring J has four rings and the piston has a like number. The cylinder head together with the piston is so formed that the compression chamber is rendered almost spherical. The position of the spark plug immediately at the top of the sphere relieves the motor of any gas pocketing. The accompanying diagram shows the horsepower curves of various types of Minerva motors, both with

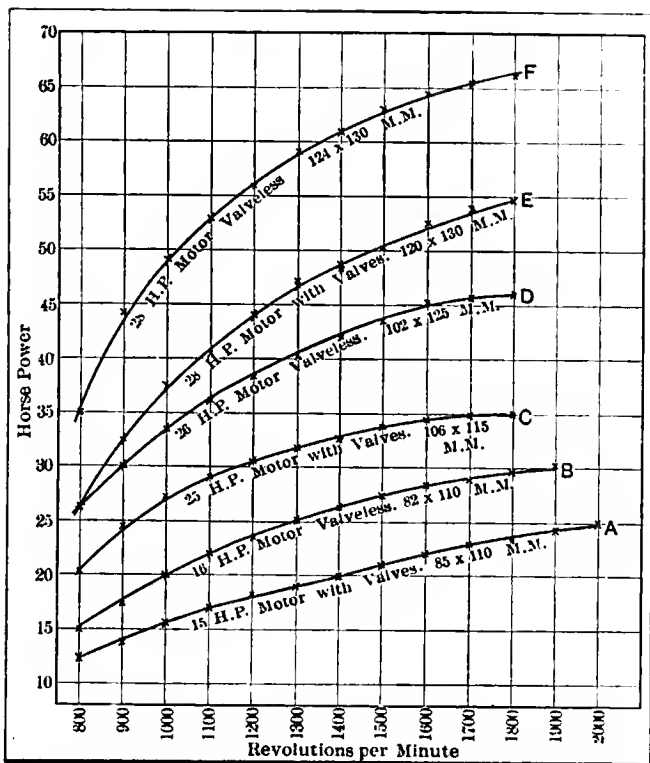

Horsepower chart showing the variations between the Minerva poppet and sleeve-valve engines

allow the port P1 to command the passage of the gases either in or out of the cylinder through the slots P2 and P3. This motor was registered by Harper and Lane.

#### Piston and Sleeve Valve Used in the Samain Motor

The cylinder is cast with a cylindrical chamber at the side, connected by a port P at the top of the combustion chamber C and provided with passageways A and B, the former being the inlet and the latter the exhaust. Laying between the wall of this cylindrical chamber and the central water-cooled column is a ported sleeve C and within this is another sleeve D which are actuated by separate cranks upon the eccentric shaft E which runs at half speed. The cranks are set at an angle of 20 to 30 degrees apart. The sleeve C is actuated as regards its downward movement through the medium of a spring F and the top of the sleeve D seats against the shoulder formed at G on the interior of the outer sleeve C. The two sleeves rise together when opposite the intake port A and the relative position of their cranks cause them to separate and put the inlet passage into communication with the chamber and engine cylinder.

During the compression and firing strokes the two valves are moved downward, the port in the outer sleeve being closed as is shown in the illustration. In registering with the exhaust port the sleeve is moved in an opposite direction, opening up the exhaust. The compression space in this motor seems to be considerable. The eccentric shaft E is driven by means of the gear G1 which is attached to the crankshaft and to the half-time gear G2. A section of the motor is shown at BV.

#### Albion Motor is Fitted with Two Piston Valves

The Albion motor shown in section in Fig. BY needs but little explanation. Piston valves operated by connecting rods attached at their lower end to small crankshafts cause the valves to reciprocate in the auxiliary cylinders A. The manifold ports C and C1 are placed in communication with the working cylinder C2 and permit the gases to be taken in or expelled from the cylinder through the passageways D and D1. The gas enters the inlet chamber by the passage E and passes out of the exhaust mani-

fold to the outlet F. The pistons B and B1 are fitted with expanding rings to insure gas tightness.

#### Two Rotary Disc Valves Used in Rowell Motor

The rotary disc valves employed in the Rowell motor, as shown in the section of a cylinder head in Fig. BZ, have all the valve faces together with the inside face of the combustion chamber first turned flat and afterward ground. The ports C and D are for the exhaust and intake respectively. The valves A and B are caused to rotate inside the cylinder C1 by means of gears G and G1 in opposite directions, thus increasing the opening and closing speed. The inlet port opens and closes on dead centers,

## New Models and New Methods of Painting

*In the present article by M. C. Hillick attention is called to the fact that the choice of colors for body painting should have some definite relation to the appearance of the body. Paint is intended to bring out the lines of the body and emphasize the builders' art. It is little use to treat all body surfaces alike, for each requires special handling.*

THE changing times imply changing methods, and the variations, however small, in style, design and model, which find expression in the 1912 car, invite—in fact, compel—some distinct, yet, perhaps, apparently minor, change in the practice of painting formerly in favor.

Painters in common with automobile owners and users are alive to the fact that the style and design—or the model, if you please—of the car body must govern to no small extent the choice of colors to be applied. In the future, at any rate, this principle will find recognition to an extent hitherto unknown.

First a study of the model, its needs—everything, in fact, that it must have to give it a compelling power of attraction—and then a scheme of color adornment in the highest degree effective to develop all the fine and shapely attributes of the car. To accomplish this result both the painter and the car owner, or the painter acting upon the authority of the car owner, must have color sense, or as it is commonly understood, "an eye for color."

This end is not gained by a lavish employment of various colors upon any single car, but rather by a simple color design in which the form of the car is not blotted out or overcast by some meaningless combination of pigments.

The mission of color is not to detract from, nor to conceal, the grace of the fashion of the builder's design. It is in the dignity of the car, and to whatever extent it fails, to that extent, we must understand, it fails in its appointed office.

The pressed steel, or, perhaps we should say more explicitly, the pressed steel sheet automobile body, will to a certain extent necessitate a method of surfacing and painting somewhat different from that which obtains under the use of the present body material.

Pressed steel surfaces, unless they come to the painter with a coat of enamel baked on, over which the paint and color structure and the varnish are forced to find a foothold, require a special treatment of which the best is a thorough sandblasting. This treatment eliminates all rust and scale formation, and insures for the subsequent coatings a foundation as honest as the heroes of ancient days.

Over this sandblasted surface a coat of metal primer—a material that dries hard and firm, yet sufficiently elastic to enable the paint fabric to respond to all the laws of contraction and

having a radial opening of 90 degrees  $\times$  the width of the port, which can be seen in the illustration. During the compression and firing strokes the ports on opposite sides of the combustion chamber are closed by the solid parts of the valves. The exhaust port is given a lead of 10 degrees for each valve, thereby obtaining an opening of 20 degrees  $\times$  the width of the port, which will give an opening with the lead of 20 degrees to the crankshaft, which, however, can be altered. By the time the piston has traveled half way up the cylinder on the exhaust stroke there is a radial opening of 100 degrees  $\times$  the width of the port. The valves are drawn up to each other by means of spring washers which will give in case of expansion. The design of this motor relies upon a film of burned oil and carbon between the valves as



expansion—should be applied. Not only contraction and expansion of the steel sheets, but their action under the strain of service vibration and roadway oscillation must, so far as possible, be overcome through the resilient nature of the priming and primary surfacing mediums.

To what extent the steel sheet automobile body will be used is hardly within the bounds of conjecture, but it is an issue which the painter will be forced to meet and plan to surmount. It is an issue, moreover, that the car owner will be vitally interested in, since appearance, and the cost of maintaining the appearance of the car depends in the last analysis upon whatever degree of durability the painter is able to establish.

Upon the primer here referred to should be applied, in due time, a surfacing coat of body and substance, touched off with enough raw linseed oil to yield a good and elastic foundation upon which, after two or three days' drying out, the necessary puttying may be done. The main thing which the painter needs to attend to at this stage of the work, and which the car owner and the party selling the car expect him to attend to, is to stop up the surface with a resolute body of pigment, supplementing this by puttying, and putty glazing any and all existing surface defects—developing, in a word, a flawless and an exceedingly strong foundation.

In all steel surfaces over which a fine, mirror-like finish is desired the first principle involved is to secure a depth and power of pigment that may be rubbed down with artificial pumice stone to a perfectly level and smooth surface without at any point laying bare the metal beneath.

As a means of avoiding this condition of things many of the best craftsmen have adopted the practice of using the rubbing stone dipped in benzine instead of water. This insures the surface from dampness, in case of getting through to the raw metal and from all the trouble following in the make of moisture.

For a high-class finish one coat of primer, one coat of filler, and four straight coats of roughstuff are needed.

All these materials may be bought, and economically bought, we believe, ready mixed and fit for the brush.

Their application deserves to be on a plane with the quality of the goods, and the painter owes it to himself, and to the present owner or prospective buyer of the car, to see that such is the case. Workmanship and quality of materials employed should precisely match if out of the combination we are to have the issues of life and length of day for the car surface.

Over the foundation above referred to belong two coats of the selected body color, with a coat of varnish—color or glaze coat to be flowed over these. Then in some cases, depending, of course, on the color selected, an additional coat of glaze or varnish color will be required. Usually this last varnish-color or glaze coat carries less pigment and more varnish.

After this coat is rubbed lightly with water and pumice stone flour the striping and ornamentation is applied over which is next flowed a coat of clear rubbing varnish. In due season this coat is rubbed thoroughly and uniformly with water and pumice stone flour, washed and cleaned, and finished with a varnish of the best body and brilliancy.

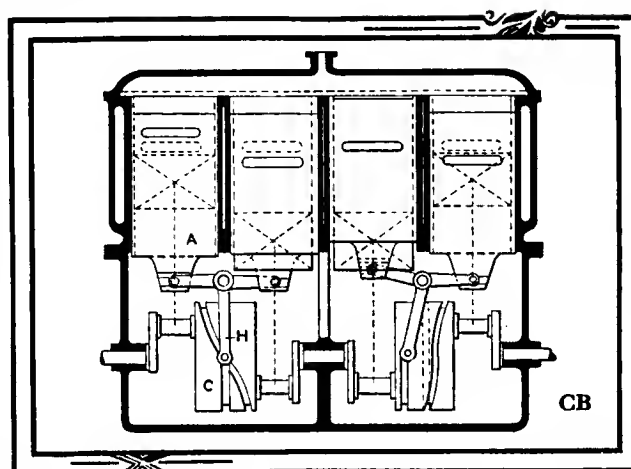

Fig. CB—Transverse section of the gaubert motor showing the method of reciprocating the sleeves

a lubricant. Apart from the shape of the ports there is nothing novel in this motor and if the question of priority should ever come up for decision this type of motor will undoubtedly furnish several claimants.

### Renault Rotary Sleeve Valves Show Originality

As has previously been stated in the columns of THE AUTOMOBILE, conservative and old makers of cars are not letting the grass grow under their feet in the matter of new types of motors. The section of the motor shown in Fig. CA is of the design patented by Louis Renault. It will be seen that there is a cone-headed sleeve B placed concentrically within the cylinder A. The sleeve is provided with four ports formed in the cone section at G and G'. The sleeve is caused to rotate through the action of the screw wheel F which engages with the helicoidal rack E. By these means the cone-headed sleeve is rotated at a speed required to close the ports to coincide with the two openings C and D as required for induction and exhaust. The speed of the sleeve is one-eighth engine speed. The outer flange portion of the sleeve above the cone is made with three grooves as shown at H for the accommodation of three compression rings which assist in forming a gas-tight joint.

In order to allow for the necessary additional period of exhaust opening as compared with inlet opening the ports in the cylinder heads are not set diametrically opposite to one another as in conventional practice. It is intended that the inlet ports shall open 10 degrees after the upper and close 25 degrees after the lower dead center. The exhaust will open 40 degrees before the lower, and close 5 degrees after the upper dead center. This gives an induction opening of 195 degrees and an exhaust opening of 225 degrees, the travel with all ports closed during the compression and explosion moments of the piston being 295 degrees and between the closing of the exhaust and the opening of the induction port 5 degrees with ports closed. An oil lead at J is provided for the lubrication of the upper extremities of the sleeve, suitable grooves being provided to conduct the oil to the sleeve proper. The shape of the combustion chamber formed by the cone head does not follow the practice set by other designers of valveless motors.

**WATER IN CYLINDERS MAKES FOR TROUBLE**—Frequently it is found that water passes into cylinders through defects in castings in which slag is enmeshed or due to misplaced corcs. A large number of cylinders are so designed that the plug in the cylinder heads fail to satisfy the requirements and water finds its way into the cylinders as a result. The defective plug is inadequate, and a plug (bronze) may be screwed in, forming the connecting link between the inner and the jacket doors. In service due to differences in heat the thread on the plug is liable to strip at the inner dome and water will readily pass into the cylinders.

# Letters Answered and Discussed

## Description of Flywheel Fan

EDITOR THE AUTOMOBILE: [2,790]—  
 Would you publish in your columns a description of the type of fan known as the flywheel fan? Is the fan separate from the motor or does it perform the office of a flywheel as well as that of a fan? I would appreciate any information that you may be able to give me on the subject.  
 C. R. STURGESS.

Penmar, Pa.

The flywheel fan is in common use. It is an integral part of the flywheel, the fan blades being the spokes of the wheel. The accompanying illustration (Fig. 1) shows the method of casting the fan. It is of use in exhausting the heated air from the motor and must be installed beneath a closed hood.

## Duryea Has Last Word

Editor THE AUTOMOBILE:

[2,791]—I grant the willingness to stick to the original question, also that an unbroken film is desirable. But you have not said what that film shall consist of. Water is a good lubricant for certain bearings. Soap-suds produces the finest films in the world and is often used for lubrication. Many oils contain soap; rosin is often present; paraffin wax is very common; kerosene is frequently found, and even gasoline in small quantities is not appreciably harmful. So your belief that a film of lubricant cannot be reasonably well secured unless the oil is free from adulteration is certainly far from having fact as its foundation. There is very little pure oil used. Most of it contains some adulterant or other, and many oil dealers will tell you the adulterant adds body and permits the "film" to do its duty. Your argument that only 1 per cent. of the users use the mixture system and there-

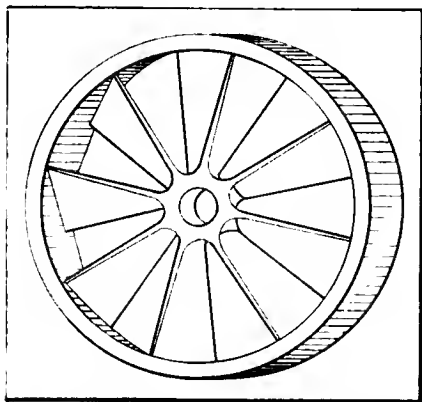

Fig. 1—Common form of flywheel fan in which the vanes of the fan are formed by the spokes of the wheel

## Announcement

### MY 1912 AUTOMOBILE

So much interest is being taken in the coming 1912 models that already criticisms are being heard to the effect that the 1912 automobile is not meeting the expectations of many readers of THE AUTOMOBILE. In order to discover exactly what are the conceptions of the many readers on the 1912 machines THE AUTOMOBILE starts this week a discussion on the 1912 models and hereby invites every reader to mail in what are his or her conceptions of next year's car. The information given should include such points as:

Horsepower  
 Bore  
 Stroke  
 Ignition  
 Lubrication  
 Carburetion  
 Clutch  
 Gearset  
 Drive  
 Springs  
 Wheelbase

Tire sizes  
 Rear axle  
 Front axle  
 Control parts  
 Body features  
 Equipment  
 Cylinder type  
 No. of cylinders  
 Cylinders, how cost  
 Price

In addition to giving these details the reasons for your points of selection should be stated concisely and clearly.

As a benefit in the matter of comparison some details of the average cars for 1911 are given herewith, these details being for cars selling at \$1,000 or thereabouts; \$1,500 or thereabouts; \$2,500 or thereabouts, and \$4,000, thereabouts and up.

Each communication must be legibly written on one side of the paper only; it must be properly signed with the writer's full name and address, and if the writer does not wish his own name to appear in print he may request the use of any nom de plume.

Any reader desiring to make line drawings, showing details of his ideas of his car or some of its parts, is requested to do so.

Editor THE AUTOMOBILE.

fore it stands condemned, is sheer foolishness. You can easily remember the time when no one drove an automobile, for there were none. The great majority of road users to-day still drive horses. It surprises me that you do not follow their lead and get onto a horse paper.

You are utterly wrong in this matter. The Holsman engine as now made offers no difficulty at all to avoid carrying the mixture into the case, but on the other hand the designer goes out of his way to

do this thing. He carries the mixture in and then out again just as any engine-maker can do, and quite evidently does it to get the perfect lubrication feed.

The real question is, Will a mixture method of feeding oil serve as well or better than a complicated mechanical feed? The answer as proven by many users and years of time is that it is better. No prejudice or argument can change this fact. It is a fact and will remain so no matter whether the public or the press believe it or not. My point is that you damage the public by misstating or hiding the real facts. I have no patent on the method, nor did I even originate it. I have used it exclusively on my limited product for some years. I know it is best. You will not need to live long to see several other tenths of 1 per cent. using it.

CHAS. E. DURYEA.

## A New Starting Handle

Editor THE AUTOMOBILE:

[2,792]—I was very much interested in a story which recently appeared in your paper regarding the way the average starting handle is put in place without any apparent regard for the comfort of the man who is to crank the car. My interest was to a great degree accentuated by the fact that my hands have undergone the same tearing process as was illustrated in that story. My object in writing you this communication is not, however, to wail over

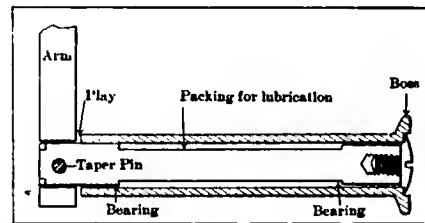

Fig. 2—A suggested form of starting crank in which the play is slightly exaggerated for the purposes of illustration

the evils that be, so much as to find a remedy therefor. In other words could you suggest a form of starting handle which will do away with the bad features you have named?

CALLOUS.

Reading, Pa.

A form of starting handle we might suggest is shown in Fig. 2, which explains itself. The play is exaggerated slightly to show better where it should be. The materials may be of anything suitable, such as a bronze core with a wood handle, or a brass handle, as preferred. The packing, if two metals were employed, may be a composition of white lead and tallow.



**Geometric Information Required**

Editor THE AUTOMOBILE:

[2,793]—Could you kindly inform me through your columns the names of the two geometric curves used in laying out gear teeth and how they are generated? Worcester, Mass. STUDENT.

The two curves you refer to are probably the epicycloid and the hypocycloid. The epicycloid is the curve generated by the circle rolling on the outside of the pitch circle and the hypocycloid that generated on the inside. Cycloids are the resulting curves when the pitch circle has an infinite radius, or in other words, is a straight line.

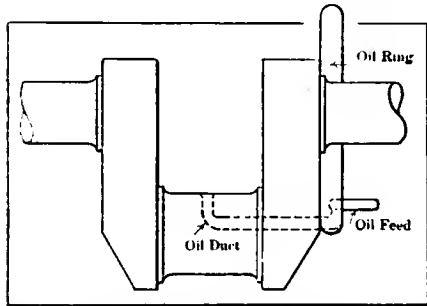

Fig. 3—Method of fitting centrifugal oil ring to crank throw. The oil duct is shown

**In Need of a Glasscutter**

Editor THE AUTOMOBILE:

[2,794]—I would like to have sight holes cut in the glass of my wind shield. The size of the holes required is from 6 to 8 inches in diameter. I notice some of these sight holes are equipped with glass coverings. Would you kindly let me know who does such work. C. P. FIELD. Peekskill, N. Y.

Any good glass cutter or wind shield maker will do the work you mention.

**Does Not Get Enough Oil**

Editor THE AUTOMOBILE:

[2,795]—My motor is lubricated by the splash system and so far as the cylinder lubrication is concerned there is no cause for complaint. The main bearings are also lubricated by the same method and are supplied with enough oil to amply lubri-

cate them. In fact, the oil is led into the central main bearing before flowing into the splash troughs. The connecting rod bearings at the crank end, however, are not sufficiently supplied and I would appreciate it greatly if you would tell me of some means whereby I could increase the supply of oil to these bearings.

EKTON PIERCE.

Coytesville, N. J.

One of the most satisfactory methods of lubricating the crank pin is by means of a centrifugal oil ring. This ring or disc is fitted against the crank cheek and is bent or stamped so as to have a hollow rim which collects the oil naturally sent to it by centrifugal force. A duct or lead as shown in Fig. 3 is fitted within this rim and a hole is drilled, as shown, into the crank pin in case the same is not hollow. If it is hollow, the drilling is of course unnecessary, except the lateral drilling from the surface of the pin. If for some reason it is impossible to fit the oil ring, and the construction of the connecting rod cap permits, a hollow scoop spoon may be fitted which will lead the oil directly into the bearing. If information is desired on the method of attachment we will gladly supply it through these columns.

**Repaired Float as Directed**

Editor THE AUTOMOBILE:

[2,797]—I repaired the leaky carbureter float as directed in your columns and found that I could get the old gasoline out better by boiling than by blowing it out. I hope this "tip" may be of use to some reader. Kingston, N. Y. R. T. CORRY.

**Wants Information on Keys**

Editor THE AUTOMOBILE:

[2,796]—I was very much interested in your reply to query 2,773 regarding the size key to use for a given shaft, and whether one key was as strong as two. In thinking over the subject it has occurred to me that the matter of the length of the key would enter into the discussion as well as the other dimensions given in your columns in reply to the above query. I would greatly appreciate your views on this

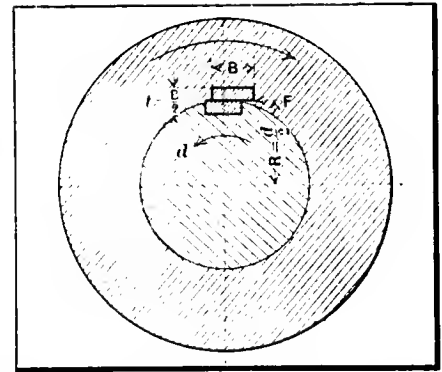

Fig. 4—Illustrating the method of failure by shear of a key and the relative dimensions used in common practice

subject, as well as an analysis of the failure of the key; that is, if it fails by shearing or by some other method of fracture.

J. SCRIVENER.

Newport News, Va.

In the design of a key the ideal condition is obtained when the ultimate shearing stress of the key is equal to the total resistance against crushing. There are other considerations entering into the problem which cannot be overlooked, among these being the wedge effect when the key is a tight fit which overcomes the crushing strain to a considerable extent. Working out an expression for length by Spooner's method:

$$\frac{d^2 \pi f_s}{16} = \frac{F d}{2} = L B f'_s d$$

$$\text{and therefore } L = \frac{d^2 \pi f_s}{8 B f'_s}$$

assuming that we wish to determine the length of the key in terms of the other quantities, and the strengths of shaft and key are equal. Referring to Fig. 4, L equals the length of the key; B, the breadth; t, mean thickness or  $B/2$ ;  $f_s$ , safe shear stress of shaft per square inch;  $f'_s$ , safe shear stress of key per square inch; F is safe shear force on key, equal to  $L B f'_s$ , and T is the moment of resistance to twisting of shaft equal to  $\frac{d^2 \pi f_s}{16} = \frac{F d}{2}$ .

**DETAILS OF AVERAGE 1911 CARS WHICH WILL ENABLE READERS TO MAKE COMPARISONS IN DISCUSSING 1912 MODELS**

	\$1,000 and thereabouts	\$1,500 and thereabouts	\$2,500 and thereabouts	\$4,000 and thereabouts
Horsepower .....	20.5	29.525	35	43.66
Bore .....	3.98 inches	4.19 inches	4.40 inches	4.875 inches
Stroke .....	4.12 inches	4.64 inches	4.98 inches	5.39 inches
Wheelbase .....	100 inches	114 inches	119 inches	124 inches
Front tires .....	31.4 x 3.3	33.1 x 3.8	35 x 4	35.7 x 4.27
Rear tires .....	31.4 x 3.3	33.1 x 3.8	35 x 4.1	36.7 x 4.55
Number of cylinders .....	Four	Four	Four	Four
Cylinder type .....	L-Head	L-Head	L-Head	T-Head
Cylinders cast .....	Pairs	Pairs	Pairs	Pairs
Ignition .....	Dual	Dual	Dual	Dual
Clutch .....	Disc	Multiple disc	Cone	Multiple disc

# Little Bits of Motor Wisdom

## Pertinent Pointers for Repairman and Driver

*A series of short stories that will tend to keep the automobilist in touch with matters mechanical and otherwise, covering a field of information that although usually well tilled, needs frequent and careful cultivation to produce the greatest results.*

**CARBURETERS BLAMED WITHOUT CAUSE**—Whenever the engine has been misbehaving for a length of time and the owner of the car has reached the conclusion

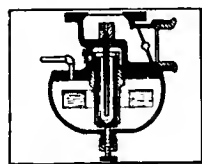

Fig. 1—Type of carburetor known as float feed, in which the supply of gasoline is governed by a cork or hollow copper float, either type being common

that it behooves him to do a little tinkering and thus cut down the repair bills, he will almost invariably start to work on the carbureter, no matter what the previous symptoms may have been. In doing this he not only exercises a commendable spirit of economy but a very unenviable lack of foresight. Any carbureter will balk if it is clogged with foreign matter or if it is not regulated so that the best carburetion may be had at the greatest range of speeds; but when an inexperienced motorist—or perhaps an experienced motorist and an inexperienced repairman—starts to work with a hammer and screw driver the result is very sure to be not only a balk but a permanent disinclination on the part of the carbureter to work at all.

The symptoms of carbureter trouble are sometimes rather elusive, it is true, but they may be located by a careful process of elimination which will after a while bring the searcher down to the heart of the matter. If the trouble is finally located in the carbureter and the matter is a lack of suitable adjustment and not a piece of cotton waste in the needle valve or other foreign matter the adjustment will have to be systematically taken up and not done in an erratic fashion, as this will only lead to greater trouble and dismay on the part of the operator. Almost any carbureter on the market will give very satisfactory service for a limited range of action, but this range is often found to be too small, and it is then that the carbureter needs adjustment. The action of the instrument may be all right at low speeds and all wrong at high, or the opposite may be the case, according to the original factory adjustment.

In the case of a float feed carbureter,

such as shown in Fig. 1, the gasoline level rises in the float chamber gradually, lifting the buoyant float until the proper level is reached so that the surface of the gasoline is about  $1/32$  of an inch below the nozzle of the jet and the current of air in passing by the jet will suck the gasoline through the orifice in the form of a spray. After having approximately regulated the gasoline level so that the float will close the needle valve at the proper time the next regulation will be in the way of a proper adjustment for the amount of air permitted to be drawn through the carbureter at medium speeds. After having the carbureter regulated so that it will work satisfactorily at medium speeds with the correct spark advance, throttle the engine and retard the spark; if heating results, close the needle valve opening slightly and observe the action. The needle valve should be closed until the motor does not smoke and runs satisfactorily, then run the engine on medium speed again and make any slight adjustment necessary. The same process should be gone through repeatedly until the motor will run well on both medium and low speeds. The adjustment is then made for high speeds in the same manner with due regard for the auxiliary air regulation if there is any. The difficulties of satisfactory carburetion are, of course, much greater at low speeds than at high speeds and there is a great tendency to draw the liquid gasoline through the manifolds in solid globules instead of the fine spray which is the ideal state in which to attain perfect vaporization the gasoline is drawn through the inlet valve in the form of a liquid will tend to form carbon deposit in the cylinder.

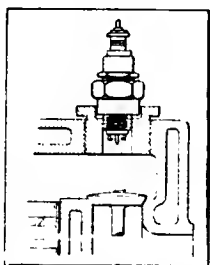

Fig. 2—Illustrating a spark plug which is too short to reach into the combustion space

indens care must be exercised that they are the correct length so that not only the maximum efficiency is obtained from them but that they are preserved from rapid wear and deterioration. The accompanying cuts, Figs. 2, 3 and 4 show the three conditions. The first shows a spark plug which is too short, the plug being in a recess in which carbon would collect and fill the gaps. The screw threads in this recess also aid in the work of holding the foreign matter in a place where it would soon foul the spark plug. The second plug is much too long, projecting far into the cylinder and subjecting itself to the hottest gases, which will soon cause the end of the plug to glow and thereby cause pre-ignition and after a time fuse the points of the plug together. The last sketch of the three illustrates a spark plug which is of the correct length. The points of the spark gap project far enough into the cylinder to effect the greatest firing efficiency possible, and the plug itself is kept cool by the surrounding walls without having any recess in which the carbon may be caught and held. Before buying the plugs this required length should be determined, as after they are purchased it is a rather difficult matter to make any correction and in most types of plug it is an impossibility. The gap should be inspected before placing the plug into the cylinder, as it is almost impossible to estimate the great losses in power and efficiency which can be traced to a weak or insufficient spark.

**SPARK PLUGS MUST BE OF CORRECT LENGTH**—In fitting spark plugs to the cyl-

inders care must be exercised that they are the correct length so that not only the maximum efficiency is obtained from them but that they are preserved from rapid wear and deterioration. The accompanying cuts, Figs. 2, 3 and 4 show the three conditions. The first shows a spark plug which is too short, the plug being in a recess in which carbon would collect and fill the gaps. The screw threads in this recess also aid in the work of holding the foreign matter in a place where it would soon foul the spark plug. The second plug is much too long, projecting far into the cylinder and subjecting itself to the hottest gases, which will soon cause the end of the plug to glow and thereby cause pre-ignition and after a time fuse the points of the plug together. The last sketch of the three illustrates a spark plug which is of the correct length. The points of the spark gap project far enough into the cylinder to effect the greatest firing efficiency possible, and the plug itself is kept cool by the surrounding walls without having any recess in which the carbon may be caught and held. Before buying the plugs this required length should be determined, as after they are purchased it is a rather difficult matter to make any correction and in most types of plug it is an impossibility. The gap should be inspected before placing the plug into the cylinder, as it is almost impossible to estimate the great losses in power and efficiency which can be traced to a weak or insufficient spark.

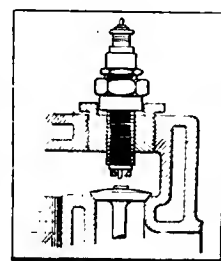

Fig. 3—Method of inviting pre-ignition. The spark plug shown is too long and will soon glow and fuse the points

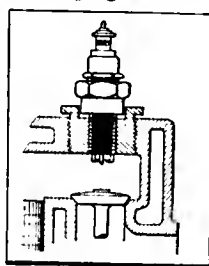

Fig. 4—Showing the proper length of the spark plug, the only part projecting into the combustion space being the sparking points

**BE PREPARED WHEN TOURING**—A touring party is, to a great degree, in the same position as an army in that it has to gather its supplies from the country through which it is traveling; hence it is very often possible that many little devices which have been the fruit of experience in the army line may be made excellent use or by the motorist. Such a device is the portable filter illustrated in Fig. 5. Suppose that the supply of water should give out far from any village or else fall so low that there is a great necessity of replacing it. To dip water from the average pool is not an advisable procedure on account of the foreign matter generally contained in such water. The portable filter is designed for just such a purpose, as it may be used for drinking water; indeed, its original purpose is just that.

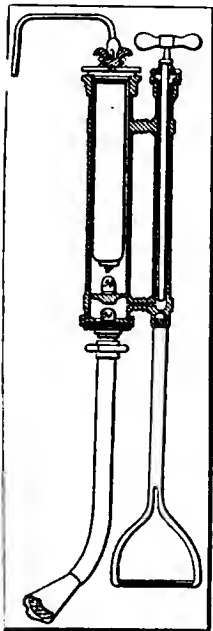

Fig. 5—Type of portable filter in use by the army. It is comparatively light, compact and easily carried

The tube, which has a strainer on the end, is placed in the pool or stream and the handle on the plunger is pulled up. This action will fill the chamber with water, while the down stroke will send it up through the filtering chamber and out of the tube at the top. Besides being of use for radiator water the device can of course be used for drinking purposes and might in this manner prove itself as valuable as when used in the former emergency.

Another great advantage of an instrument of this type is the fact that the capacity is unlimited, while the vacuum bottles which are sold to tourists under various trade names have a very small capacity and hence an entirely limited sphere of usefulness. The vacuum bottle is designed not as a source of permanent supply but to furnish the owner the luxury of a hot or cold drink when such are not readily obtainable. It is by no means safe to drink from a stream of unknown source, no matter how clear and limpid its waters may seem as there are many disease germs which are carried an incredible distance by means of a stream, and although the apparently uninhabited state of the country may indicate that it is safe to risk the few longed-for swallows it is much better and safer to have filtered water when possible. Well water itself is often poisoned, especially if the well is comparatively shallow, by its nearness to

foul cisterns or garbage dumps in country houses.

Solid matter within the radiator will eventually be deposited on the radiating walls and greatly impair its utility, and indeed after a time cut down the power of the engine by not adequately cooling parts which cannot stand a higher temperature than that for which they are designed. If the circulation is clogged up the water will also tend to boil and hence form steam which will leak past the joints and by its much greater temperature than the water from which it was formed, greatly augment the deposit of scale on the cellular surfaces.

**ONE KEYWAY SUFFICIENT TO HOLD A SHAFT**—It is not necessary to cut away unnecessary material by making two or more keyways when it is a fact that one key will hold as well if not better than any number if it is properly designed and if the key is of proper material. In the accompanying cut, Fig. 6, D is the diameter of the shaft, W the width of the key, A the depth of the keyway and R the radius of curvature of the edges of the keyway. The key is of the correct size when it is of equal strength in all ways, that is, when the resistance to shear is the same as the resistance to torsional strains. The ideal condition and the one which is made the aim in all the dimensions given by the standard manufacturers, is that in which the moment of inertia of the key about the diameter of the shaft is the same as that of the shaft about the same diameter. To illustrate the size key required for a shaft of common size it may be well to consider a particular case. Take D equal to 1 1/4 inches; W will equal 3/16 inch. A 3/32 inch and R .04 inch. If it were figured out mathematically it would be found that the moment of inertia of the circle less that which was taken away to make room for the key would be equal to the moment of inertia of the key.

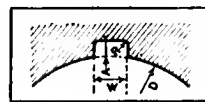

Fig. 6—Illustrating form of a standard keyway. A, depth of key; D, diameter of shaft; W, width of key; R, radius of curvature of key

**DIRECTION OF MAGNETO CURRENT ALTERNATES**—As the armature rotates between the two pole pieces in the ordinary magneto the current is generated by the cutting of the magnetic lines of force between the north and south poles of the magnet. Fig. 7 illustrates the armature in diagrammatic form as being in one of the positions taken up during a complete revolution. It is evident that as the armature continues to rotate the part which is nearest the north pole will be nearest the south pole, and the current instead of running from a to b will take an opposite

direction. It is thus evident that there is a reversal in direction of the current at every 180 degrees through which the armature passes. Since the current passes through this reversal in direction it is very evident that there is a point where there is no current at all since it would be impossible to change from one direction to the other at the same instant. An examination of the cycle of events also shows that the current becomes less as it approaches this point until it reaches zero, it then increases until it is a maximum after the armature has revolved through 90 degrees from the point of zero current. In magneto timing a point is made therefore, of arranging the gears so that the spark is given at the point of as near maximum current as possible under the greatest number of conditions.

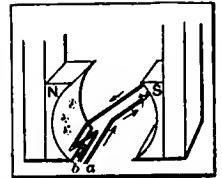

Fig. 7—Illustrating the direction of the current when the armature takes up the illustrated position. Current flowing from a to b.

**BALL CHECK VALVES MUCH USED**—The ball check valve is one of the smallest and most compact forms of satisfactory non-return valve. It is true that this type of valve is occasionally charged with having a great penchant for sticking if great precaution is not used in keeping it clean. The uses for the ball check, however, are so great that in some cases where there are no chances of its fouling, it is practically infallible, as for plunger oil pumps, etc.

In the illustration Fig. 8, a ball check is shown. The liquid is free to flow through the pipe in one direction without any interference on the part of the ball check, but when there is a tendency to flow back the pressure forces the ball into its seating and very effectually checks the flow. It is in the case of the ball being thrown violently into its seating that the sticking tendency makes itself felt to the greatest degree. This is especially so if there is any oil deposit on the seat or if foreign matter has collected there to any extent. In some forms of oil pumps the ball check valves are to a great extent self-cleaning since they are arranged in such a way that the flow of oil takes away any deposit which may have accumulated.

Another cause of sticking in this type of valve is that the balls are often too small and sink into the aperture much further than intended. It does not take much of an indentation to hold the ball firmly in place, while if too large it is apparent that they are apt to become stuck.

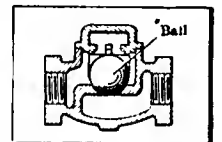

Fig. 8—Form of non-return valve known as the ball check, often accused of having a great penchant for sticking

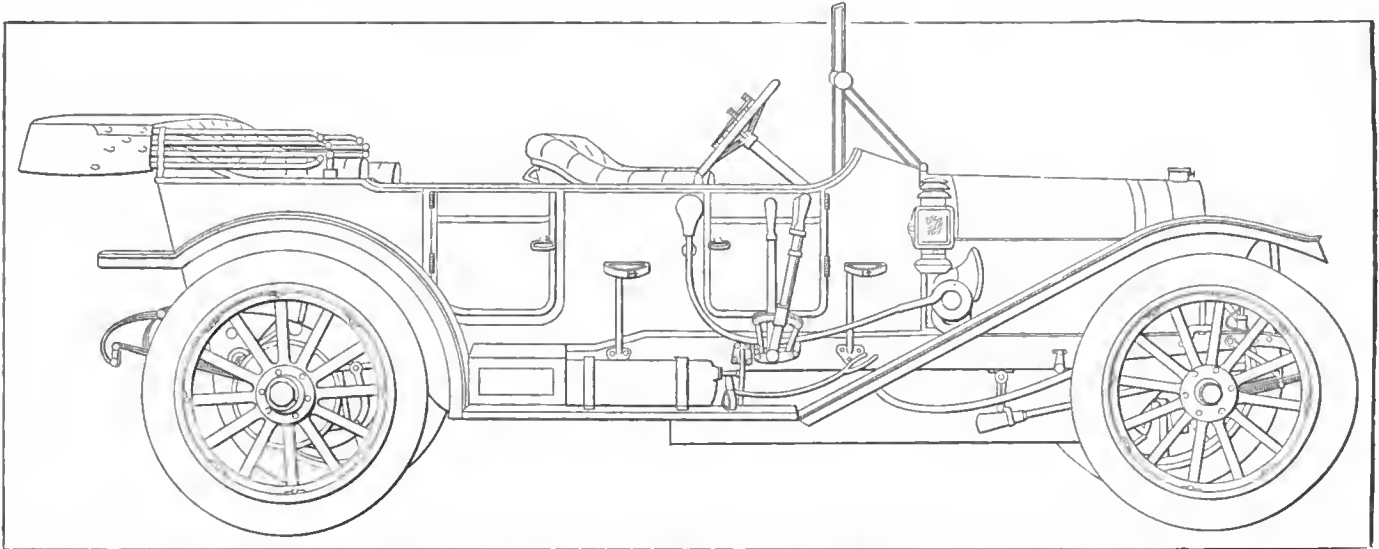

Fig. 1—Right-hand side view of the 50-horsepower Kissel Kar Semi-Touring car showing the general equipment and the disposition of the side levers

## Details of the Latest Kissel Kars

### Principal Mechanical Features Analyzed

*The latest line of Kissel Kars manufactured by the Kissel Motor Car Co. of Hartford, Wis., gives the buyer the choice of four types of chassis with a very complete assortment of bodies. Three models are fitted with four-cylinder motors, the 60-horse-power, however, being fitted with six.*

**I**N order to meet a varied demand the Kissel Kar is made in four types of chassis, commencing with the 30-horse-power runabout, selling at \$1,500, to the six-cylinder, 60-horsepower limousine. The outstanding features of the body construction are shown in Figs. 1 and 2, fitted respectively to a 50 and 60-horsepower chassis. The general construction of the various types is uniform, and the motors have the cylinders cast in pairs. Fig. 4 illustrates the motor of 60 horsepower looking at the inlet side. The cylinders are cast in pairs with L-heads, the valves being placed all under one side. The general neatness and clean appearance of the motor is enhanced by the valve

covers C<sub>1</sub>, C<sub>2</sub> and C<sub>3</sub> which are readily removed by unscrewing a single thumb nut for each cover. The crankcase of the motor is cast from aluminum in two halves. The lower half forms a well and oil is forced from a special tank by a gear-driven pump to every section of the motor. An oil level is provided allowing the flow to be adjusted to meet any condition automatically. The oil pump P is shown on the right-hand side of the motor in Fig. 4 and it will be seen that there is a lead taken direct from the lower half of the base chamber and after passing through the pump the oil is forced back into the motor through the lead O. The shaft driving the pump is operated by means of double

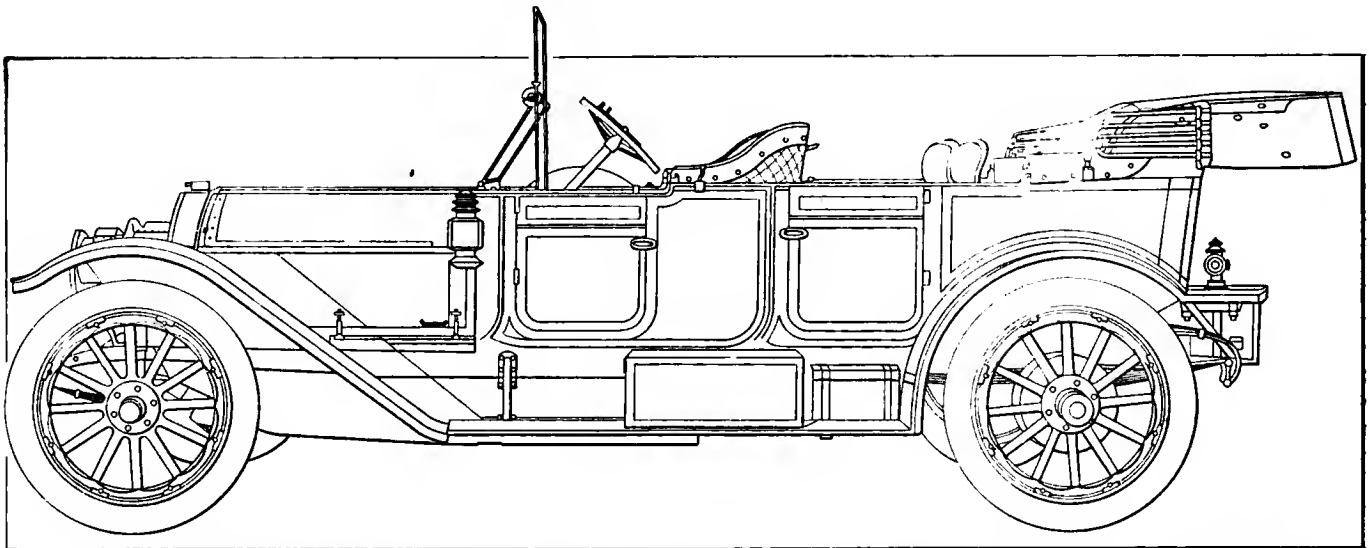

Fig. 2—General appearance of the six-cylinder 60-horsepower touring car with flush-sided fore-door touring body for seven passengers

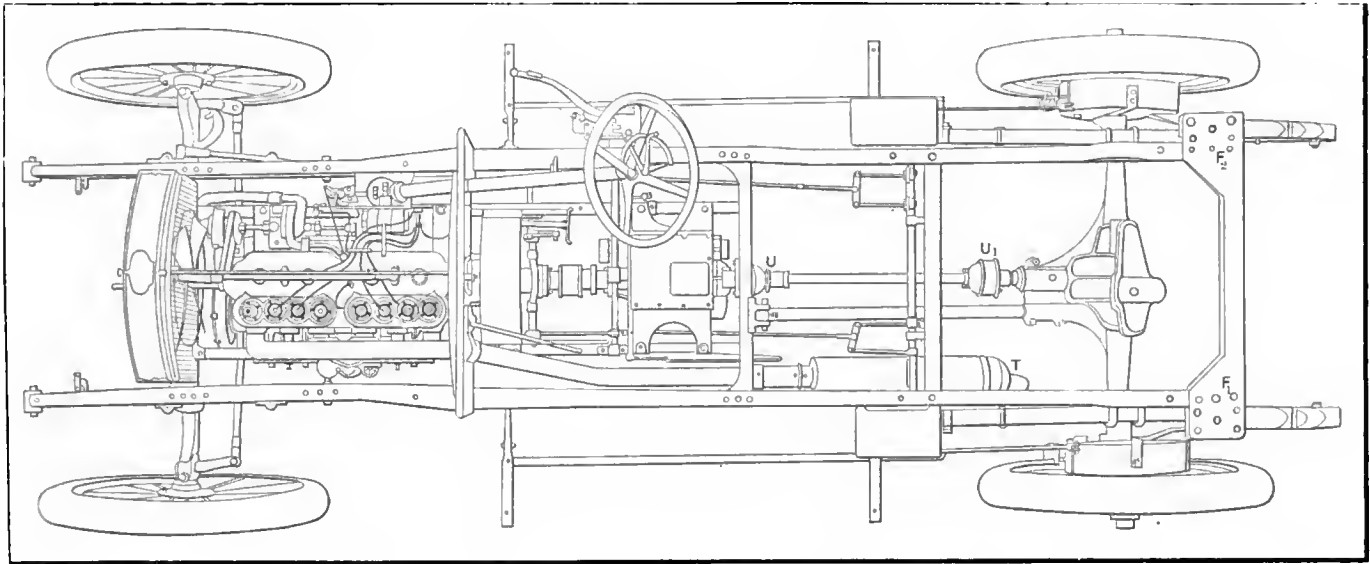

Fig. 2—Plan view of the four-cylinder 40-horsepower chassis showing the general arrangement of the units

gearing off the end of the camshaft and has a split joint to facilitate the removal of the pump without disturbing the gearing.

In addition to grinding the motor parts to size in Kissel motors they are first ground and afterward lapped by a special machine with the part within which it operates. The cylinders of the 60-horsepower motor have a bore of 4.1-2 inches with a stroke of 4.3-4 inches. The intake manifold is branched at three points and is attached to the cylinders by means of brackets B which are held in position by a nut. The same brackets serve to hold the exhaust manifold E in position, but it is possible to remove the intake manifold by undoing the center stud without disturbing the exhaust manifold. The intake manifold at the point where the vertical pipe from the carburetor meets the former is of larger diameter than the remainder of the piping. This allows for a certain degree of expansion and prevents the choking of the gases, which is one of the difficulties to be overcome in carburetion for six-cylinder motors. The water pump is driven by a shaft which carries the fan pulley on the opposite side of the motor, from the half-time gearing, and the water leads W<sub>3</sub>, W<sub>2</sub> and W<sub>1</sub> are connected by the piping P<sub>2</sub> and P<sub>3</sub>, whence the water is delivered to the radiator, which is of the tubular type.

The ignition is furnished either by a Mea or Bosch dual system to spark plugs placed over the intake valves. Compression and priming cocks are provided and fitted in the valve covers over the exhaust valves.

The carburetor C is on the float-feed type with the mixing chamber heated by water from the water circulating system.

Passing to the four-cylinder motor shown in Fig. 6 it is possible to examine the method employed of operating the pump and the magneto. At the base of the cylinder on the right-hand side there is a drain cup C<sub>2</sub> which permits the driver to drain all the water from the cylinders in frosty weather. Such a provision, sometimes overlooked, is an absolute necessity and it is essential that drain cups should be placed at the lowest point of the circulation to allow of every drop of water being drawn off. A similar provision is made below the pump. The pump is fitted with two packing glands fore and aft together with greasers, and the extension of the pumpshaft is

fitted with an Oldham coupling G<sub>1</sub>, which permits the magneto M to be removed readily. The magneto M rests on a ledge cast integral with the motor and is held in position by means of a bridge H. The bracket B is bolted to the motor casting and the bolt passes through this and secures the bridge in position above. Studs are provided in the ledge below which fit into counter-sunk holes in the base of the magneto.

The motor is suspended by four arms which rest on a sub-frame attached to the main frame, as can be seen by referring to Fig. 3. Stand pipes B<sub>1</sub> and B<sub>2</sub> in Fig. 6 act as breathers for the motor and at the same time serve for pouring oil into the base chamber.

A cone clutch of the conventional type is utilized to transmit the power from the motor to the transmission, a universal joint being placed between the two members to compensate for any disalignment and unevenness of the road which might cause flexure in the chassis. The subframe that carries the motor is extended rearward and attached to a cross-member of the main frame. A general view of the transmission is shown in Fig. 7, from which it can be seen that the shafts are placed vertically

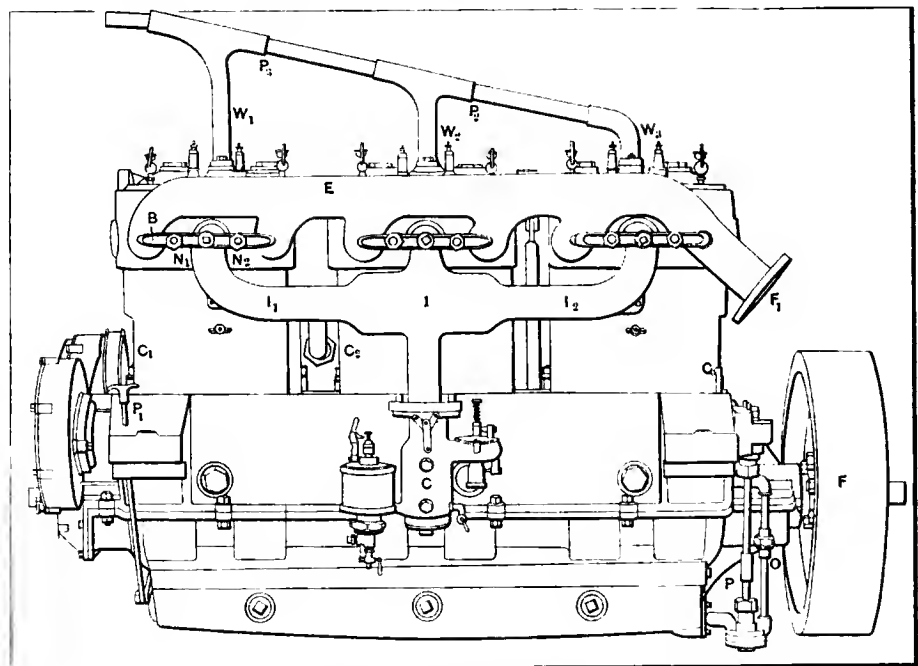

Fig. 4—Left-hand side of the six-cylinder motor showing the carburetor and manifolds together with water pump



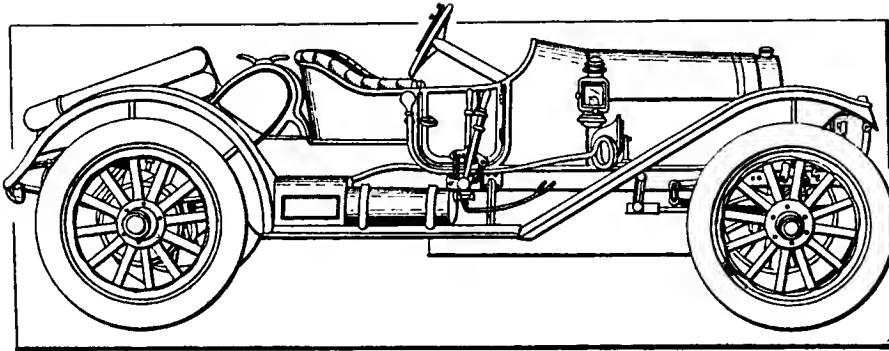

Fig. 5—Right-hand side view of the 30-horsepower semi-racer with gas tank and tires carried on the rear platform

one above the other. The arms  $A_1$ ,  $A_2$ ,  $A_3$  and  $A_4$  support the aluminum casting from the subframe and the clutch shaft is attached by means of bolts to the flange  $F_1$ . The primary and secondary shafts are carried upon ball bearings of ample section. The transmission here shown is of the four-speed type as fitted to the 50 and 60-horsepower chassis, but in the 30 and 40-horsepower chassis three speeds obtain. The gear wheel  $G_1$  carries a series of dog catches which when engaged with a corresponding set of dogs on the gear  $G_2$  forms the fourth speed direct drive or third as the case may be. Gears  $G_1$  and  $G_2$  serve respectively for the first and second speeds. The gears slide upon a castellated shaft and are moved into position by the lever arms  $L_1$  and  $L_2$ . A cover  $C$  is provided at the rear end of the striking arms  $A$  to exclude any dirt from this part of the mechanism and to retain the lubricant necessary for easy operation. At the rear end of the gear box attached to the primary shaft there is a flange  $F_2$  with arms to take the cross head of the forward universal joint. The propeller shaft, being fitted with two universal joints, one at each end as shown in Fig. 3, is not inclosed and the torque from the live rear axle is taken up by the torque member running parallel to the propeller shaft and terminating at its forward end in a swivel bracket attached to the cross-member frame. The rear end of this member fits into a sleeve of the rear axle and is held in position by means of two bolts. A general idea of the rear axle can be obtained by referring to Fig. 8. It is of the full floating type, the shaft  $S_1$  being connected with the dog  $D_1$  which engages with the hub of the wheel. The wheels are carried upon roller bearings  $B_1$  and  $B_2$  which are securely held in position by the locking nuts  $L$ . The jaws  $J_1$  and  $J_2$  accommodate one of the two universal joints and a suspender bar is placed below the axle and is fitted with an adjusting piece  $B_3$ . The rear side of the axle casing proper is fitted with a cover  $C_1$  which when removed allows the differential to be taken out of its housing after the jackshafts have been removed.

Particular attention seems to be paid to one of the most vital parts of the car's mechanism. The method of operating the brakes is shown in Fig. 4, which are of the internal expansion and external constricting types operating upon a drum which is attached to the rear wheels and having a diameter of 14 inches and a width of 5 inches. In order to prevent the external constricting brakes from rubbing on the drum and chattering, springs  $S_2$  and  $S_3$  are provided and the locking screw  $A_1$  holds the brake hand in such a position that it cannot exceed the limits of which this screw is set. The lever  $L_1$  operates the internal brakes, while the external brakes are taken care of by the lever  $L_3$ . Fig. 3 shows the method employed for compensating the action of the brakes, the cross bar being carried by short arms attached to the cross-member of the frame.

The wheelbase of the respective models is as follows: Thirty-horsepower, 116 inches; 40 horsepower, 118 inches; 50 horsepower, 124 inches, and 60 horsepower, 132 inches. The front axle is an I-section drop-forging and the connecting bar for the steering arms is placed behind the rear axle. The suspension of the car is taken care of by semi-elliptic springs at the front

end and three-quarter elliptic at the rear, the half springs being securely held in position by the frame extensions  $F_1$  and  $F_2$ , shown in Fig. 3.

A neatly designed semi-racer is turned out by the Kissel Company, an illustration of which is shown in Fig. 5. The brake and chain speed levers are placed outside the side doors of the body in order to accommodate the tires of the rear platform; the gasoline tank, which is of oval formation, is placed slightly at an angle.

In the matter of equipment it is the policy of the Kissel Company to include in the purchase price practically everything that the autoist finds it a necessity to have

on the car, and on the larger models there should be little else for the purchaser to buy in the way of extras after the car is delivered.

## Shock Absorber Idea Old

*The idea of a device for arresting the motion of a body gradually and hence without shock is not of very recent origin, but has been used with success in a great many instances where heavy moving weights have to be brought to rest in a short space of time without undue strain.*

ONE of the oldest schemes is the shock absorber idea; it had its inception when railroad trains were brought into vogue, and the so-called bumper on a freight car would be incomplete without a shock absorber. In freight-car work, where the shock absorber has to contend with strenuous conditions, there are two principles in common use, one of which depends upon the action of a spring, and the other upon friction. Discussing these two principles, it will be readily appreciated that the spring idea takes into account the desirability of gradually absorbing the energy stored in the moving mass. Spring bumpers produce train oscillations, due to the fact that the springs give back, in a reactive sense, the energy stored in them, and enough work is done in the form of oscillations to absorb the energy of impact of the cars as they bump into each other. That the energy must be absorbed before the cars will be brought to rest is self-evident, but a more quiet way of obtaining the desired result is represented in the form of bumper that dissipates the energy through the medium of friction, which is the

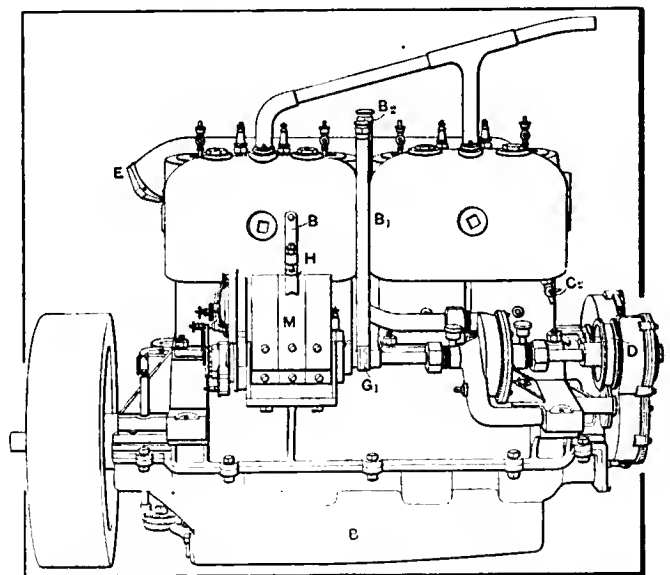

Fig. 6—Magneto side of the four-cylinder motor showing the method of drive and attachment

second principle involved. The friction bumper has no reaction component; all the work is dissipated in the form of heat. As regards the instability of some forms of shock absorbers employed in automobile work, it can only be explained on the ground that the method of utilizing the principle is too frail. If bumpers can be made which will do the work in freight-car practice, involving long trains, surely they can be so contrived that they will serve perfectly in stopping the vertical bounce of the chassis frame and its load as represented in an automobile. Some designers use these absorbers to supplement work that should be performed by the suspension springs, whereas these latter should be made strong enough to do their allotted work without extraneous assistance.

### Purpose of the Differential

*In turning a curve it is required that one wheel will revolve faster than the other; in order to make this possible the two wheels cannot be on one solid shaft, but will have to be separated by a break. The differential is inserted in this break and makes the difference in speeds practicable.*

THE differential gear is fitted, in order to allow one driving wheel to be run faster than the other, in other words, to absorb a greater share of the motion transmitted from the engine, but at all times that driving wheel receives the same amount of push or torque. Even if one wheel should be stationary while the other one is rotated—as when taking a very sharp corner—the push or torque to each wheel remains the same, because the two are connected through the medium of the differential gear, or balance gear as it may more correctly be termed, and, consequently, the turning effort which is applied to the rotating wheel is resisted by an equal and opposite force—the braking effort of the stationary wheel. The relative amount of movement of the two wheels, however, may differ very widely.

The operation of a differential gear, or balance gear, may best be understood if we imagine a man holding a rod by its center and parallel to the back axle, so that its two ends bear against the rear sides of two spokes—the top one in each of the two road wheels on the same axle. If he then pushes the rod forward and, assuming the axle and wheels to be free to move for-

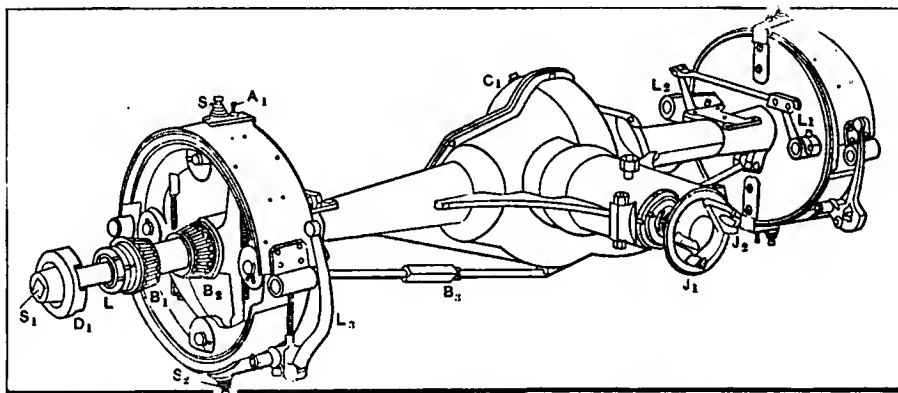

Fig. 8—Live rear axle of the full floating type employed in Kissel Kars

ward in a straight line only, he will transmit an equal amount of motion to each of the road wheels, but, if the axle and wheels are being steered round a corner, and, consequently, one of them requires to run faster than the other, the ends of the rod which acts as a beam will be rotated about the man's hand until they slide out of contact with the spokes of the road wheels. If we substitute for the simple rod a rimless star wheel, consisting of a hub and spokes only, the push of the man's hand may then be more or less continuously transmitted to the wheels, because, as one rod, or diametrically opposite pair of spokes in the star wheel, slides out of engagement with the spoke of the road wheels, another pair of spokes in the star wheel enter into engagement with others on the road wheels. This is practically what happens in the case of the differential gear. The star wheel is carried in a frame, which is driven round the center of the axle, and its spokes mesh with other spokes on the driving wheel.

### Harking Back a Decade

TEN years ago a system of steam wagonettes made by the Mobile Company of America was put into service in New York City. The wagonettes plied between the Cortlandt and Wall street ferries and at the time the project was hailed with much acclaim as an improvement on one phase of New York's rapid transit. The enterprise has been so long forgotten that few residents even remember that it ever existed.

Experiments with motor-driven farm machinery and military wagons were being pursued.

The case of the original joy rider was noted when an employee of a Cleveland establishment used one of the firm's electric cars to give some of his lady friends a good time.

The idea of installing a carburetor for each cylinder was being gravely discussed.

The sporting section of motordom had its attention centered on the Newport Road race on the Ocean Drive. This race was later prohibited by the Rhode Island courts and was run off in Aquidneck Park, the winner turning up in W. K. Vanderbilt's Daimler, called the "Red Devil."

Ralph Estep wrote an essay on "Brazing Automobile Frames" in *The Motor Review* that reads like an account of modern practice.

Miles T. Baird and party motoring through the Yosemite valley found much hostility along the way.

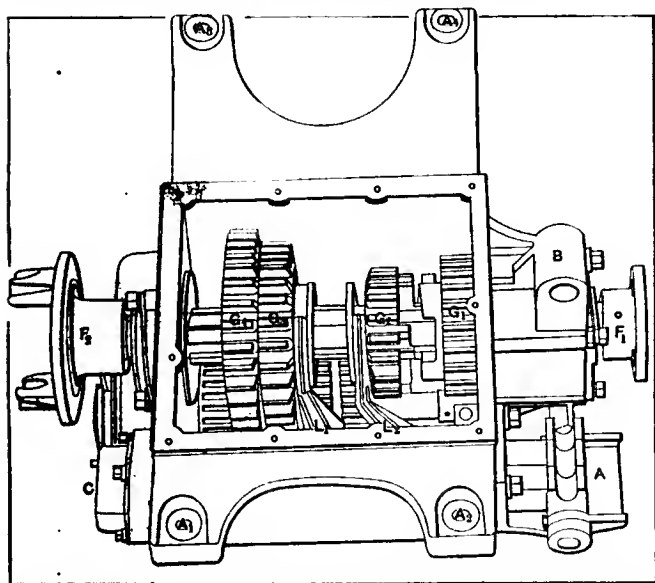

Fig. 7—Plan view of the gear box of the 50-horsepower Kissel Kar, showing the relation of the several members

**GRAVITY FEED TANKS**—In gravity feed work the gasoline tank must be located at least one foot above the float bowl of the carburetor, which condition is independent of every other consideration. In pressure feed work the gasoline tank is located below the deck of the body, and generally below the top of the chassis frame. Round or oval tanks are preferred; walls without curves bulge out unless they are braced by means of surge plates, of which two are used in most tanks. The tank generally conforms to the space provided by each type of chassis.

# Stoddard-Dayton in Perspective

## Six-Cylinder Knight Features the Line

*In addition to several successful cars of the past season the Dayton Motor Car Co., of Dayton, Ohio, has incorporated in the forthcoming season's list of models a new car fitted with Silent Knight motor.*

THE Stoddard-Dayton Knight as adopted by the Dayton Motor Car Co., has a motor fitted with six cylinders of 4 1-2-inch bore and 5 1-2-inch stroke. The general principle of the Knight motor is sufficiently familiar by this time, so that no useful purpose can be gained by going into the details of the motor. The sectional view shown in Fig. 1 gives a concise idea of the co-relation of the sliding sleeves at the moment of induction with the intake ports in register. The piston has a concave head, and the compression chamber being similarly formed, pocketing is entirely eliminated and the maximum effect of the explosion is thereby obtained.

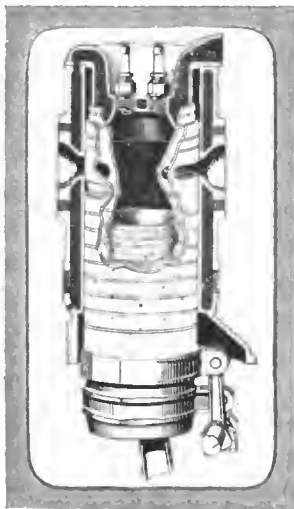

Fig. 1—Section through a cylinder of the Stoddard-Dayton Knight motor

It will be noticed that two spark plugs are fitted to each cylinder and it is possible, as will be shown later, to cause the

spark to take place at both spark plug points practically simultaneously. The water jacketing, as can be seen from the illustration, is well taken care of, there being no protruding points likely to cause auto-ignition.

Although the piston has a stroke of 5 1-2 inches it is scarcely this so far as its friction is concerned because the sleeve moves down 1 1-8 inches. This facilitates lubrication and reduces wear on the side of the sleeve. On the compression stroke both inner and outer sleeves go up with the piston, the inner sleeve moving the faster. On the exhaust and induction strokes the sleeves move in an opposite direction to the piston; but on these strokes

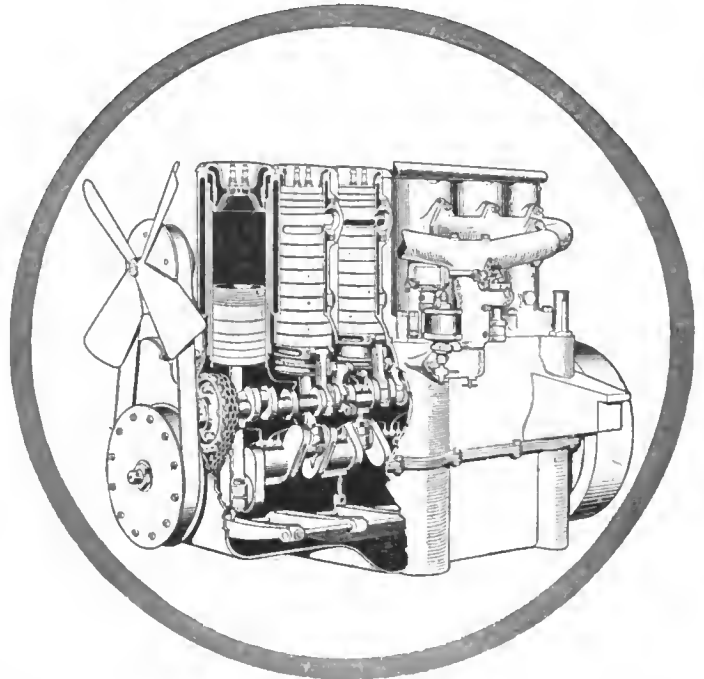

Fig. 3—Part sectional view of the Stoddard-Dayton six-cylinder Knight motor

there is very little work being done by the piston and consequently there is a minimum of side thrust. The sleeves descend with the piston on the working or explosion stroke when the piston has the greatest amount of side thrust against the sleeve, thereby eliminating to a certain degree some of the thrust.

The up-and-down movement of the sleeves is comparatively short. The piston stroke of 5 1-2 inches gives a piston speed of

916 feet per minute and 1,000 revolutions per minute of the motor. The stroke of each sleeve is 1 1-8 inches and its speed is but 93.7 feet per minute. This fact should be borne in mind by skeptics when endeavoring to solve the lubrication question as well as the wearing possibilities of this type of motor.

Fig. 3 shows a part sectional view of the Stoddard-Dayton Knight motor in which the eccentric shaft carrying the small eccentric rods is shown, driven by a silent chain from the crankshaft. Each cylinder has a separate port and the method in which the intake manifold is formed is clearly shown.

The crankshaft is of large diameter and runs in seven main bearings, which give a large bearing surface besides adding stability to the motor. In the upper half of the crankcase there are core ways



Fig. 2—Stoddard-Dayton chassis mid-section, showing control, clean dash and transmission

to which the air enters before reaching the carbureter. This serves two purposes, as the air is warmed passing through the base and the sound of inrushing air which prevents an otherwise quiet motor from performing silently is eliminated.

The lubrication of the Knight motor is effected by means of six troughs located transversely beneath the six connecting rods. The troughs are carried at one end on a boss shaft which is connected with the throttle. When the throttle is opened, which raises the troughs, the scoops on the ends of the connecting rods slip deep into the oil, thereby atomizing it and bathing the lower ends of the sleeves, whence the oil finds its way into the grooves cut in the sleeves shown in Fig. 1. The sleeves are drilled so that the oil can pass from one sleeve to the other. The troughs are kept replenished to overflowing by means of an oil pump situated at the base of the motor, and

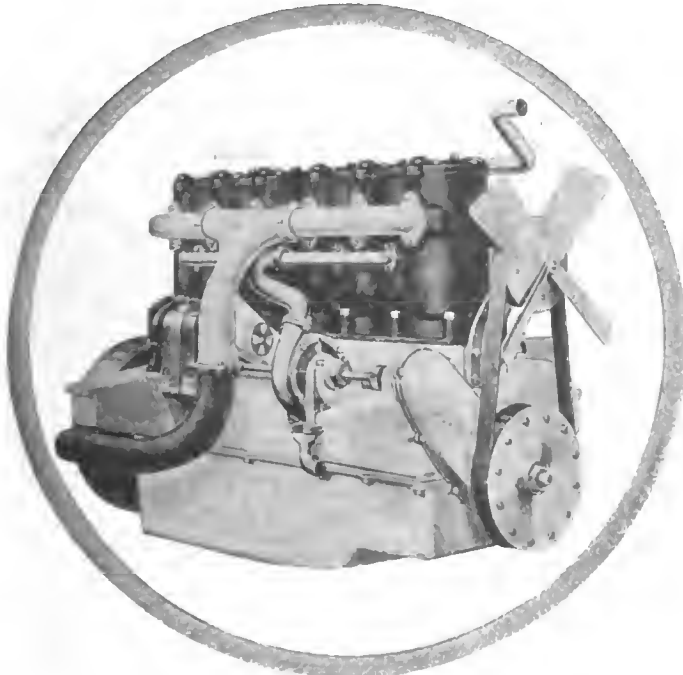

Fig. 4—Exhaust side of the 6-cylinder Stoddard-Dayton Knight motor, showing the water pump and magneto

by means of an adjustment it is possible to maintain the feed of oil to the speed requirements of the motor. A level gauge is fitted at the rear end of the motor to show the amount of oil in the sump.

Fig. 4 shows the right-hand side of the motor, disclosing the separate-ported exhaust manifold, the centrifugal water pump and the high-tension magneto, which are driven by means of a silent chain in a similar manner to the eccentric shaft. An air passage will be noticed partially surrounding the exhaust manifold, which conducts air through the cored passageway in the base chamber to the carbureter. A rotary shutter is provided so that the temperature of the air may be regulated and cold air admitted if found desirable. The front end of the crankshaft is extended through the base chamber and attached thereto with a pulley which drives a heavy 1 1-2-inch flat belt which in turn operates the four-bladed solid cast aluminum fan. The fan runs on annular ball bearings, carried in an eccentric collar so that adjustment of the tension of the belt can readily be made. The front of the crankshaft is equipped with a damper in order to overcome any

tendency of uneven running of the motor at high engine speeds.

The ignition is furnished to the spark plugs from a two-spark high-tension ignition system controlled by the one switch and coil on either magneto or battery through two sets of plugs. The carbureter is of the constant-level automatic type, the mixing chamber of which is heated by a circulation of warm water. The auxiliary air valve is provided with an adjustment controlled by a short lever on the steering post, which allows variations to be made while the car is running, thereby placing at the driver's disposal a ready and certain means to meet the daily variations in temperature, humidity, and so on.

Fig. 8 shows the Stoddard-Dayton valve-in-the-head motor, the salient external features of which are apparent from the illustration. Heretofore the expulsion of exploded gases has been dependent in a large measure upon the movement of the piston, but as the compression chamber cannot be entirely scavenged by the piston a certain residue of the burnt gases always remains behind which intermingles with the fresh gases that are taken in on the induction stroke. In order to overcome this a multiple manifold is provided, and within the outer exhaust manifold are various pipes and chambers so designed that when one cylinder is exhausting the action forms a suction in the pipe of the next cylinder to be exhausted. The right-hand side of the valve-in-the-head motor can be seen by referring to Fig. 10. Independent camshafts are provided for the inlet and exhaust valves and the method of operating the valves can be seen in the illustration.

In order to differentiate between the various models manufactured by this concern names have been chosen for the different types of chassis instead of letters. The "Special" is a 58-horsepower chassis, four-cylinder, 5-inch bore by 5 1-2-inch stroke, and has a wheelbase of 130 inches for the touring and limousine bodies and 122 1-2-inch wheelbase for the four-passenger torpedo and two-seated roadster. The "Saybrook" model has a motor of 48 horsepower, the bore 4 3-4 with 5-inch stroke and a wheelbase of 122 1-2 inches. The "Stratford" model is fitted with a 38-horsepower motor with L-head motor, the cylinders being 4 1-8-inch bore and the stroke 5 1-4 inches, the wheelbase of the chassis being 114 inches. The "Savoy" model is fitted with an L-head motor, the cylinders of which are 4-inch bore and 4 1-2-inch stroke, with 112-inch wheelbase. The smallest model manufactured is the "Courier" chassis, with a 30-horsepower motor, 3 3-4 inches bore and 5 1-8-inch stroke, the wheelbase of the chassis being 106 inches. The various chassis are fitted with an exceptionally complete line of body work, a few examples of which are shown in the accompanying illustrations. The chassis particulars of the "Knight," "Special," and "Saybrook" models are identical. The clutch fitted to Stoddard-Dayton cars on these models is of the leather-faced cone type, the cone being of cast aluminum faced with leather

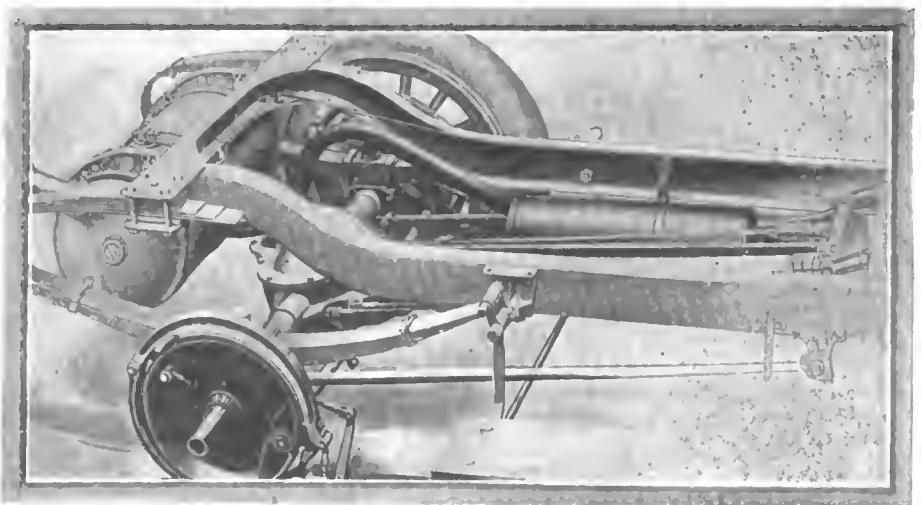

Fig. 5—Rear construction of the Stoddard-Dayton "Special," showing the elliptic springs and frame

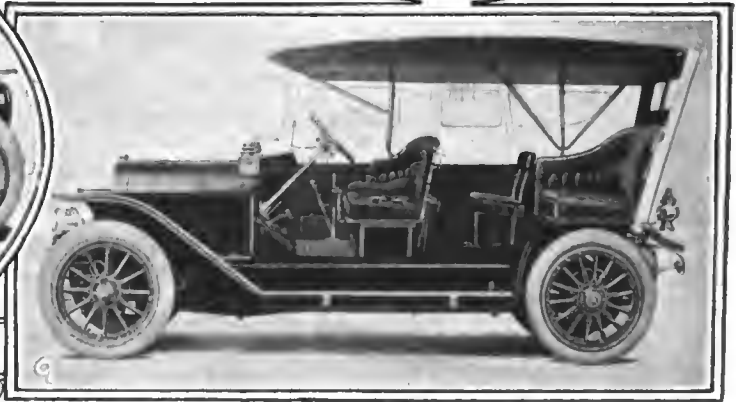
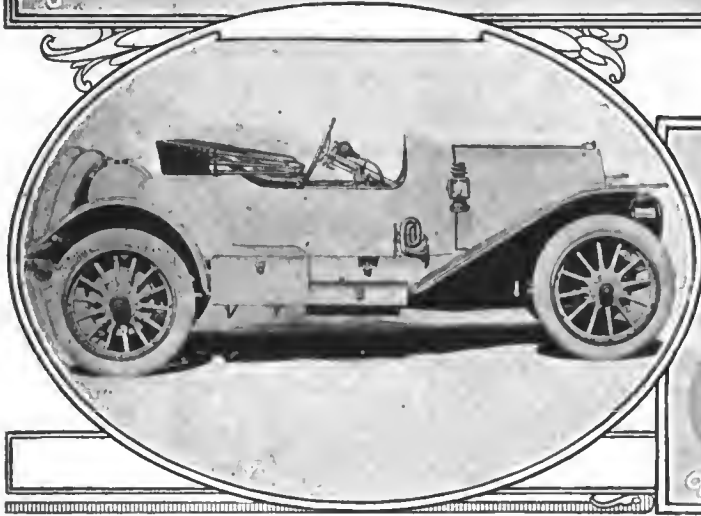
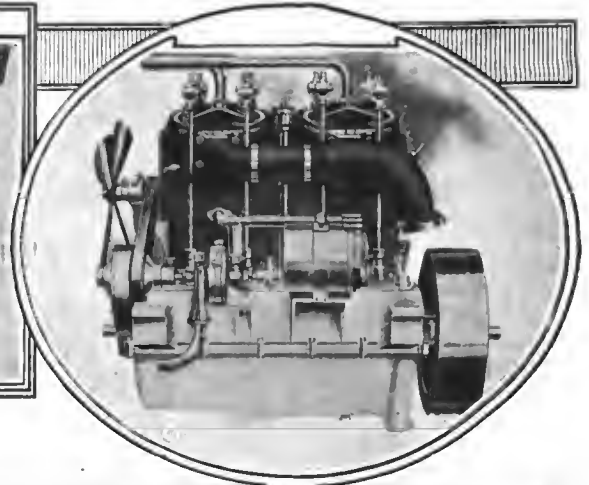
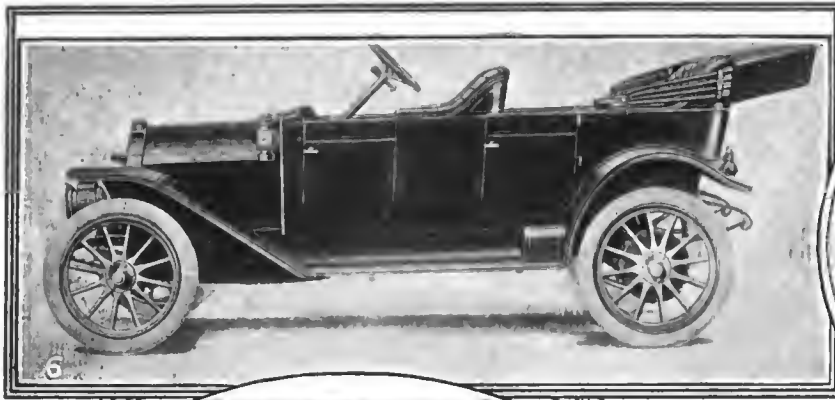

Fig. 6—General appearance of the Stoddard-Dayton "Savoy" type of touring car

Fig. 7—Stoddard-Dayton compartment torpede with dust and water-proof luggage compartment

Fig. 8—Exhaust side of the Stoddard-Dayton valve-in-the-head motor, showing the multiple exhaust manifold

Fig. 9—Side view of a Stoddard-Dayton touring car, showing roominess for the occupants of all seats

and backed by a large number of flat flexible springs to cause the leather to raise in spots, thereby giving a gradual operation and eliminating shocks to the transmission through careless engagement. Ball bearing thrusts are used inside and out and the clutch spring is self-contained, eliminating end thrusts on the crankshaft while the motor is running. A general idea of the appearance of the transmission gear, shift lever, pedals and control is given in Fig. 2. The transmission is of the selective type, giving three speeds forward and one reverse, the shafts being carried upon double annular ball bearings; steam type packing glands are employed, which permit the use of a thin lubricant without the fear of leakage through the bearing housings. Between the clutch and transmission there is a double sliding universal joint, the casing of which is drop forged and hardened and the blocks are also hardened to eliminate wear.

Fig. 5 shows the general arrangement of the live rear axle, brake mechanisms and torque rods. The propeller shaft connecting the transmission to the bevel gearing is fitted with a universal joint at the forward extremity and is supported by a torsion tube which is held in its front end in a bolt joint allowing sliding motion fore and aft in addition to its universal movement. Radii rods are fitted at each end with universal joints, thus doing away with any binding or cramping action that would impede their proper functioning or cause undue wear and rattling. The axle of the three above-mentioned models is of the full-floating type with jackshafts turned from chrome nickel steel. The axle casing is fitted with a cover which when removed gives complete access to the working parts and permits the differential to be removed readily.

The front axle is made from a cold drawn bar of what is known as "Plow-Beam" section, having reinforcements at the corners to guard against the twisting strains to which front axles are subjected.

Shock absorbers are regular equipment of the "Knight," "Spe-

cial" and "Seabrook" models. Two sets of brakes are provided, operating upon the drums attached to the rear wheels and forming part of the hub flange. The drums are 14 inches in diameter on the "Saybrook" model and 16 inches in diameter on the "Special" and "Knight" models. The external brake has a two-part, forged steel, I-shaped band 2 1/2 inches wide, hinged and

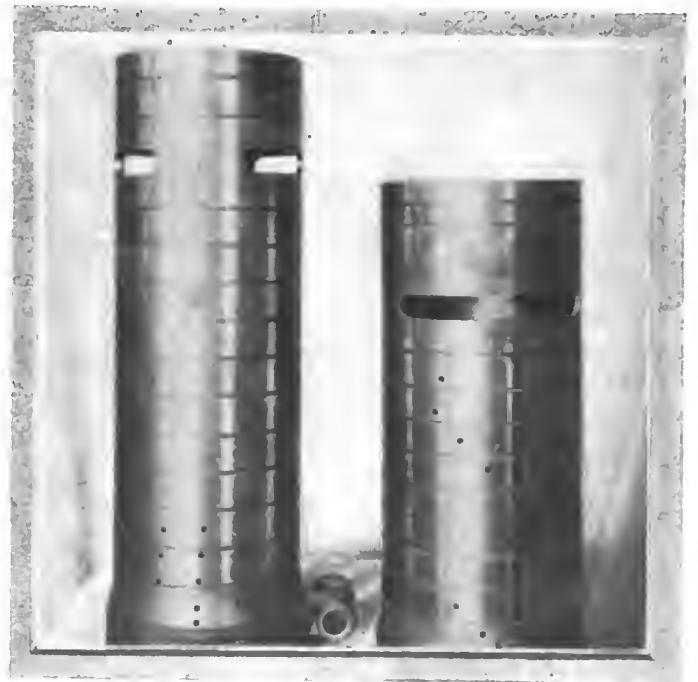

Fig. 14—General view of the inner and outer sleeve, showing method of slotting and diagonal drilling for lubrication



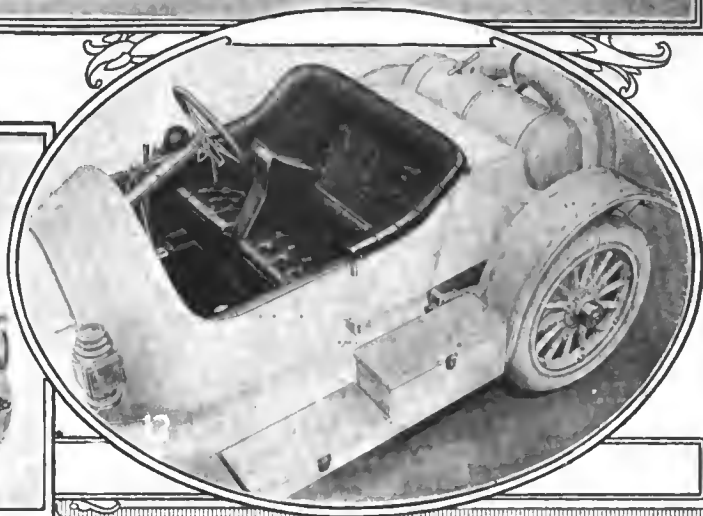
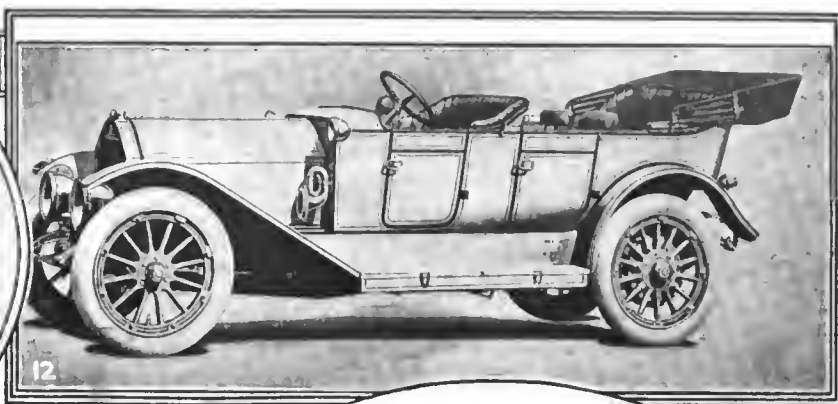
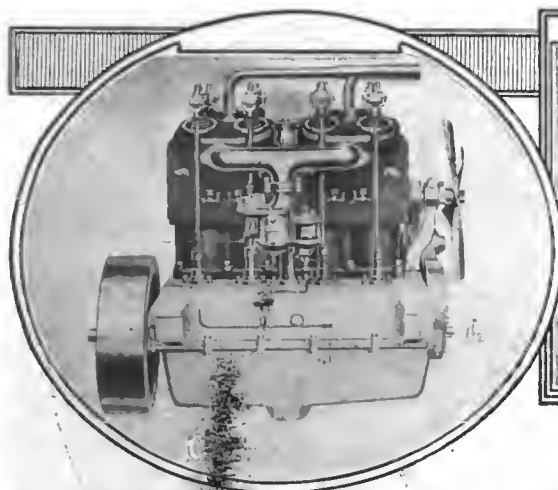

Fig. 10—Intake side of the Stoddard-Dayton valve-in-the-head motor, showing the carbureter with special air valve regulated by lever from the steering post

Fig. 11—Stoddard-Dayton "Stratford" three-passenger coupé

Fig. 12—Flush sided seven-passenger body, fitted to a Stoddard-Dayton-Knight chassis

Fig. 13—Interior view of Stoddard-Dayton compartment torpede, showing accessibility of luggage space

faced with raybestos. All connecting rods are now placed on the inner side of the frame and the brake adjustment is made by means of turn buckles, which are easily accessible, as they lay directly beneath front floor boards. The suspension of the car is taken care of by 3-4 elliptic springs at the rear and semi-elliptic springs at the forward end, the leaves being 2 1-2 inches

in width. The spring bolts have large diameters and are fitted with grease cups. The frame is on the pressed steel type of U section, pressed cold from a medium carbon steel, the stock being 3-16 of an inch with 2 1-4 inch flanges. In order to eliminate body squeaks and vibration the bodies are set on rubber bumpers in the frame.

The radiator is of the cellular type, with distributing manifold for spreading the water to the sides as well as to the center of the cooling core.

In the three models under notice the front seats are entirely separate from the body and are adjustable forward and back, giving drivers of various leg lengths a means of adjustment. The 2-passenger car shown in the illustration, in which the compartment is of sufficient size to carry two suit cases, is a distinct innovation.

## Stoddard-Dayton at Close Quarters

The staff man of THE AUTOMOBILE had an opportunity, thanks to the courtesy of the manager of the New York branch of the Dayton Motor Car Company, of inspecting the first six-cylinder Knight motor that had been manufactured in America.

The front block of cylinders was dismantled, which gave an opportunity of inspecting the various working parts after the car had run a matter of 3,000 miles. The photographs of the parts shown in Figs. 14 to 19 show the state of the motor better than words can express it. It was not expected that any wear would take place in so short a distance, but what it did show was that a perfect film of oil is maintained between the various surfaces and that discoloration of the ports was a negligible quantity.

It may be mentioned incidentally that the Stoddard-Dayton

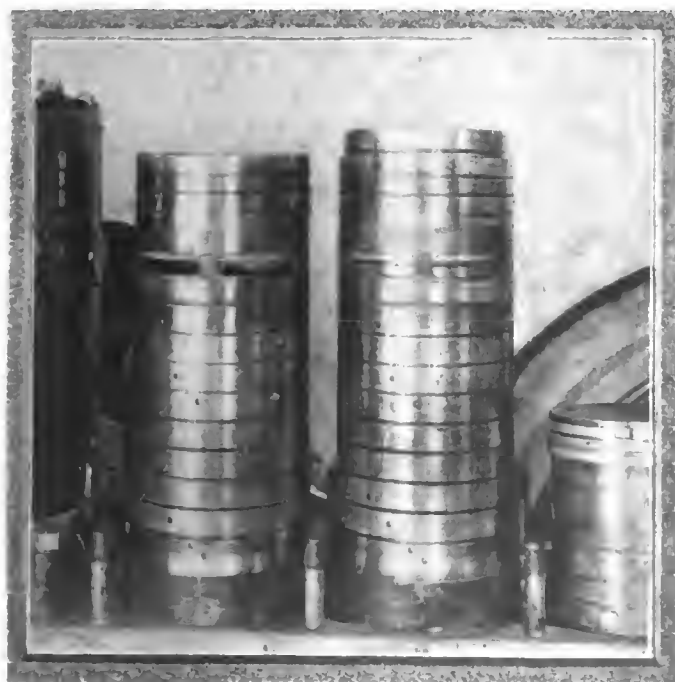

Fig. 15—Appearance of sleeves of Stoddard-Dayton-Knight motor, exhaust side, after having run three thousand miles

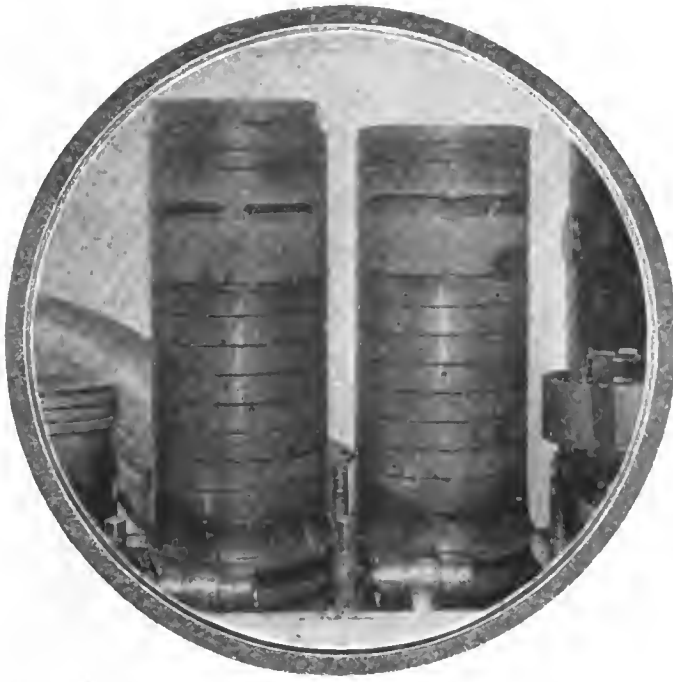

Fig. 16—Appearance of the sleeves of the Stoddard-Dayton-Knight motor, intake side, after having run three thousand miles



Fig. 18—Exhaust side of Stoddard-Dayton-Knight motor, showing central web in the passage-way forming a support for connecting piece in sleeve

Knight motor is the longest stroke motor of this type that has so far been manufactured by any of the companies who build motors under the Knight patents. Fig. 14 shows a general view of the inner and outer sleeves. The method of ringing the sleeves in the form of circular grooves can be seen so that the lubrication will be properly taken care of and prevent an excess of oil being carried up into the combustion chamber. Each of the sleeves has been drilled to permit the lubricant to freely circulate, and as the outer sleeve is the longer of the pair this has been drilled with holes set diagonally to the axis of the piston in the manner shown in the illustration. Another feature of the sleeves can be seen in the vicinity of the longer or outer sleeve port. Small slots are cut radially above and below the port which in time collect a certain amount of the carbon deposit and tend to keep the cylinder port free from any foreign matter.

A slight idea of this can be seen by referring to Fig. 15, which shows two of the sleeves on the exhaust side of the motor after the cylinders had been removed. Again, referring to Fig. 16, the appearance of the sleeves on the intake side shows an absolutely clean surface, the polish left by the grinding machine being still discernible. The valve timing of this motor is particularly worthy of notice as it varies from previous Knight practice. The intake valve opens on top dead center and closes 40 degrees after lower dead center, while the exhaust valve

opens 50 degrees before lower dead center and closes 12 degrees after top dead center, which allows a lapping of the two valves of 12 degrees.

The external appearance of the cylinders of the motor, which are cast in two blocks of three each, do not adequately show the size of the ports; but there is a considerable difference in the shape of the intake and exhaust ports. Fig. 17 shows the intake ports, which consist of a straight slot, circular in form, which cannot be shown in a photograph as the casting at this point tapers outward, allowing the slot in the cylinder to register the same size as the slots in the sleeves. It will be noticed in Fig. 15 that there is a slight rib placed in the middle of the slots, which registers with the web in the port shown in Fig. 18. This rib is of lesser diameter than the sleeve and consequently does not rub either against the piston or the cylinder wall. The width of the slot is  $\frac{9}{16}$  of an inch, which has been found the best working dimensions for this size of motor. In order to overcome the inconveniences that sometimes attend the proportionate flow of gas from the carburetor to the cylinders the induction manifold has been cast with internal baffle-plates, thereby distributing the gases evenly to the separate ports.

A point that was first of all extensively adopted in the Knight motor is shown in Fig. 19. In this illustration the method of driving the eccentric, pump and magneto shafts is shown. Two sprocket wheels are attached to the extension of the crankshaft and the two silent chains drive the sprocket wheels that are attached respectively to the eccentric and pump shafts. These chains run continually in a bath of oil and besides being silent in operation, should offer very little wearing possibilities.

Left-hand driving has been incorporated in the Knight Stoddard-Dayton car and the change speed and brake levers are located on the right hand side of the driver. The electric lighting system, that is a regular feature on this car, is driven by a silent chain from the shaft that is situated between the clutch and the transmission. By removing the floor boards immediate access is obtained to this part of the equipment and its location leaves the motor surroundings entirely free. The piston rings of this motor differ from conventional practice; the grooves in the piston and cylinder head are fitted with two independent rings, the inner one being slightly eccentric, while the outer is cylindrical. Besides the general features already outlined, several minor improvements are worthy of notice. A neat arrangement is provided for altering the timing of the magneto with-

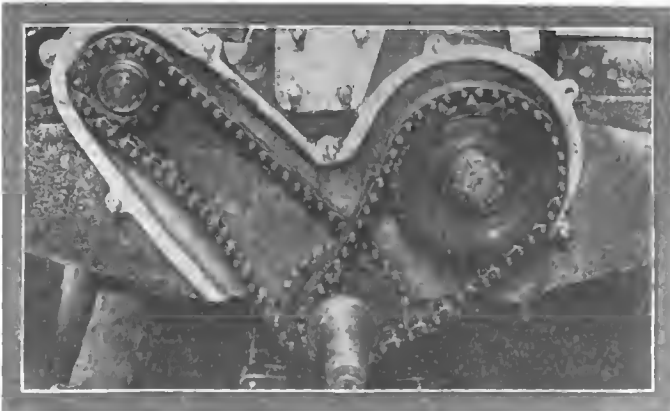

Fig. 19—Silent-chain drive employed on the Stoddard-Dayton-Knight motor

out disturbing the distribution gear. The water piping and tubing that carry the ignition wires are neatly executed and removable by simply loosening the nuts instead of having to take them off entirely. Pressure for the gasoline tank is derived from a small pump driven by a short arm off the eccentric shaft, in which case only atmospheric air is employed and filtration eliminated.

### Program for Old Orchard Meet

OLD ORCHARD, ME., Aug. 21—W. T. Kincaid, who is promoting the motor races on Old Orchard beach for next month beginning Labor day, has mapped out a program covering three days' racing. There are 17 events on the list divided up according to the A. A. A. rules. The first two days have six each with five on the third day. Cash prizes will be given in the greater number of the events, there being one amateur contest scheduled. The list of events follow:

#### FIRST DAY, SEPTEMBER 4.

- Event 1, Class C—Non-stock, 161 to 230, 5 miles, entry fee \$10, prize \$50.
- 2, Class B—Stock chassis, 231 to 300, 10 miles, entry fee \$10, prize \$50.
- 3, Class D—Free-for-all one-mile time trials, no entry fee, prize \$50.
- 4, Class B—Stock chassis, 451 to 600, 10 miles, entry fee \$10, prize \$50.
- 5, Class E—Special amateur event, 5 miles, open to any car privately owned, owner to drive, entry fee \$5, prize trophy.
- 6, Class D—Free for all, 10 miles, entry fee \$15, prize \$100.

#### SECOND DAY, SEPTEMBER 5.

- Event 1, Class B—Stock chassis, 161 to 230, 5 miles, entry fee \$10, prize \$50.
- 2, Class C—Non-stock, 451 to 600, 10 miles, entry fee \$10, prize \$50.
- 3, Class D—Free-for-all one-mile time trials, no entry fee, prize \$50.
- 4, Class B—Stock chassis, 301 to 450, 10 miles, entry fee \$10, prize \$50.
- 5, Class C—Non-stock, 231 to 300, 5 miles, entry fee \$10, prize \$50.
- 6, Class D—Free for all, 10 miles, entry fee \$15, prize \$100.

#### THIRD DAY, SEPTEMBER 6.

- Event 1, Class E—Stock chassis under 301 cubic inches, 5 miles, entry fee \$10, prize \$50.

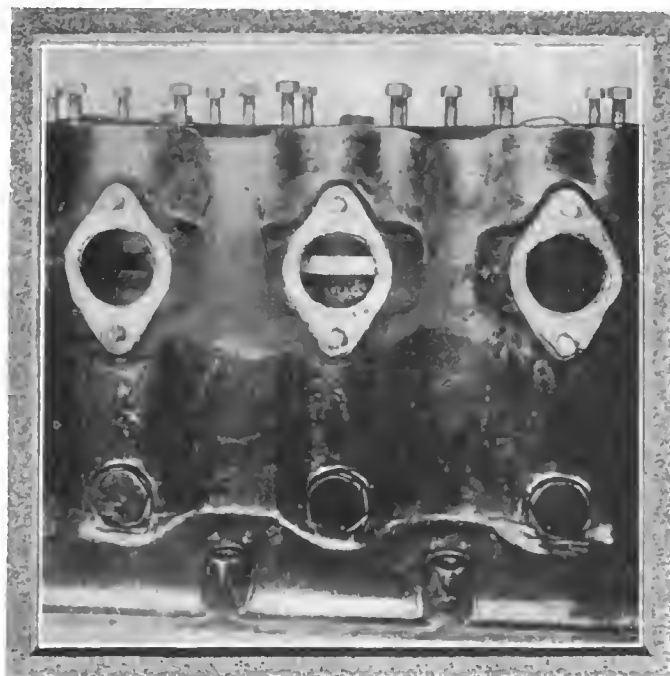

Fig. 17—General appearance of the three-block cylinder, showing the intake ports with the manifold and cylinder heads removed

- 2, Class E—Stock chassis, 301 to 600 cubic inches, 10 miles, entry fee \$10, prize \$50.
- 3, Class D—Free-for-all one-mile time trials, no entry fee, prize \$50
- 4, Class D—Free for all, 10 miles, entry fee \$15, prize \$100.
- 5, Class E—Non-stock under 600 cubic inches, 25 miles, entry fee \$20, prizes \$100 to first and \$25 to second.

# Calendar of Coming Events

## Handy List of Future Competitive and Show Fixtures

### Shows

- Jan. 1-5, 1912.....New York City, Grand Central Palace, Annual Show, Automobile Manufacturers' Association of America.
- Jan. 6-13.....New York City, Madison Square Garden, Twelfth Annual Show, Pleasure Car Division, Automobile Board of Trade.
- Jan. 10-17.....New York City, Madison Square Garden, Annual Show, Motor and Accessories Manufacturers.
- Jan. 10-17.....New York City, Grand Central Palace, Twelfth Annual Show, National Association of Automobile Manufacturers.
- Jan. 15-20.....New York City, Madison Square Garden, Twelfth Annual Show, Commercial Division, Automobile Board of Trade.
- Jan. 27-Feb. 10....Chicago Coliseum, Eleventh Annual Automobile Show under the auspices of the National Association of Automobile Manufacturers.

### Race Meets, Runs, Hill-Climbs, Etc.

- Aug. 25-26.....Elgin, Ill., Stock Chassis Road Race, Chicago Motor Club.
- Sept. 1.....Oklahoma, Reliability Run, *Daily Oklahoman*.
- Sept. 2.....Pottstown, Pa., Track Races, South Jersey Motor Club.
- Sept. 2.....Scranton, Pa., Track Races, Automobile Association of Scranton.
- Sept. 2, 3, 4.....Kansas City, Mo., Track Races, Automobile Club of Kansas City.
- Sept. 2-4.....Amarillo, Tex., Track Races, Panhandle Auto Fair Association.
- Sept. 2-4.....Brighton Beach, N. Y., Track Races.
- Sept. 3.....Columbus, O., 200-mile Race, Columbus Automobile Club.
- Sept. 4.....Denver, Col., Track Races, Denver Motor Club.
- Sept. 4.....Salem, N. J., Track Races, South Jersey Motor Club.
- Sept. 4, 5, 6.....Old Orchard, Me., Beach Races, Old Orchard Automobile Association.
- Sept. 6-9.....Buffalo, N. Y., Grade I, Reliability Run, Automobile Club of Buffalo.
- Sept. 7-8.....Philadelphia, Track Races, Philadelphia Auto Trade Association.
- Sept. 8-9.....Hamline, Minn., Track Races, Minnesota State Automobile Association.
- Sept. 9.....Augusta, Me., Hill Climb.
- Sept. 9.....Cincinnati, O., Road Race, Fern Bank Dam Association.
- Sept. 9.....Hartford, Conn., Track Races, Connecticut Fair Association.

- Sept. 9.....Port Jefferson, L. I., Hill Climb, Port Jefferson Automobile Club.
- Sept. 9.....Riverhead, L. I., Road Race, Port Jefferson Automobile Club.
- Sept. 13.....Grand Rapids, Mich., Track Races, Michigan State Auto Association.
- Sept. 15.....Knoxville, Tenn., Track Races, Appalachian Exposition.
- Sept. 16.....Philadelphia (Point Breeze), Track Races, Philadelphia Automobile Trade Association.
- Sept. 16.....Syracuse, N. Y., Track Races, Automobile Club and Dealers.
- Sept. 18-20.....Chicago, Ill., Commercial Reliability Run, Chicago Motor Club.
- Sept. 19.....Burlington, Vt., Reliability Run, Merchants' Protective Association.
- Sept. 23-25.....Detroit, Mich., Track Races, Michigan State Agricultural Society.
- Sept. ....Denver, Col., Track Races, Denver Motor Club.
- Sept. ....Detroit, Mich., Reliability Run, Wolverine Automobile Club.
- Sept. ....Steubenville, O., Hill Climb, Automobile Club of Jefferson County.
- Oct. 6-13.....Chicago, Ill., Thousand-Mile Reliability Run, Chicago Motor Club.
- Oct. 7.....Danbury, Conn., Track Races, Danbury Agricultural Society.
- Oct. 7.....Philadelphia, Fairmount Park Road Races, Quaker City Motor Club.
- Oct. 7.....Springfield, Ill., Track Races, Springfield Automobile Club.
- Oct. 13-14.....Atlanta, Ga., Track Races.
- Oct. 14.....Santa Monica, Cal., Road Races.
- Oct. 14 to 25.....New York City, Start of the Annual Glidden Tour, en route for Jacksonville, Fla.
- Oct. 16-18.....Harrisburg, Pa., Reliability Run, Motor Club of Harrisburg.
- Nov. 1.....Waco, Tex., Track Races, Waco Auto Club.
- Nov. 2-4.....Philadelphia, Reliability Run, Quaker City Motor Club.
- Nov. 4-6.....Los Angeles, Phoenix Road Race, Maricopa Auto Club.
- Nov. 9.....Phoenix, Ariz., Track Races, Maricopa Automobile Club.
- Nov. 9, 11, 12.....San Antonio, Tex., Track Races, San Antonio Auto Club.
- Nov. 27.....Savannah, Ga., Vanderbilt Cup Race, Savannah Automobile Club.
- Nov. 30.....Los Angeles, Cal., Track Races, Motordrome.
- Nov. 30.....Savannah, Ga., Grand Prize Race, Savannah Automobile Club.
- Nov. ....Columbia, S. C., Track Races, Automobile Club of Columbia.
- Dec. 25-26.....Los Angeles, Cal., Track Races, Motordrome.



Voi. XXV Thursday, August 24, 1911 No. 8

THE CLASS JOURNAL COMPANY

H. M. SWETLAND, President
A. B. SWETLAND, General Manager
231-241 West 39th Street, New York City

EDITORIAL DEPARTMENT

GEORGE M. SCHELL
JAMES R. DOOLITTLE HUGH P. MacCONNELL
J. EDWARD SCHIPPER HANS WEYSZ

ADVERTISING DEPARTMENT

W. I. RALPH, 1035 Old South Bldg., Boston LOUIS R. SMITH, New York
C. H. GURNETT, 910 South Michigan FRANK B. BARNETT, 309 Park
L. G. VOGEL, Avenue, Chicago Building, Cleveland
T. B. VAN ALSTYNE, New York and Phila. H. H. GILL, 627 Ford Building,
H. L. SPOHN, New York Detroit

Cable Address - - - - - Autoland, New York
Long Distance Telephone - - - - - 3046 Bryant, New York

SUBSCRIPTION RATES

United States and Mexico - - - - - One Year, \$3.00
Other Countries in Postal Union, including Canada - - - - - One Year, 5.00
To Subscribers—Do not send money by ordinary mail. Remit by Draft,
Post-Office or Express Money Order, or Register your letter.

FOREIGN SUBSCRIPTION AGENTS

ENGLAND:—W. H. Smith & Sons, Ltd., 186 Strand, London, W. C., and all book-
shops and agencies in Great Britain; also in Paris at 245 Rue de Rivoli.
FRANCE:—L. Baudry de Saunier; offices of "Omnia," 20 Rue Duret, Avenue
de la Grande Armee, Paris.
GERMANY:—A. Seydel, Mohrenstrasse 9, Berlin.

Entered at New York, N. Y., as second-class matter.
The Automobile is a consolidation of The Automobile (monthly) and the Motor
Review (weekly), May, 1902, Dealer and Repairman (monthly), October, 1903,
and the Automobile Magazine (monthly), July, 1907.

CLEAN UP NEW YORK STATE

SEPTEMBER 1 has been selected as housecleaning
day for the State of New York. On that date the
new law, making it a misdemeanor to post bills on trees,
stumps, posts, fences, stones and hundreds of other
places without the permission of the property owner, goes
into effect. On the same day it has been suggested that
everybody interested in the future welfare of the Em-
pire State use his or her influence for the general im-
provement of the appearance of the countryside, the small
villages, the towns and even the cities.

Housecleaning New York State is not any child's play.
In some places trees have been covered from the roots
as high up the trunk as the energetic bill poster has been
able to reach; every old building near the highway has
been converted into a crazy-quilt advertising sign; every
corner fence has been covered.

To remove all this debris will require energy; it will
require co-operation, and it will require organization.
Spasmodic mixtures of printers' ink disfiguring a beau-
tiful landscape do not add to the joy of the automobil-
ists outing, and now that the State has taken the matter
in hand it is up to the automobile owners to get together
and help the good work along.

The best way for the automobilists is to get busy at
once. September 1 will be pretty late. Get the enthusi-
asm, at least, worked up before that date. The New
York State Association should take the lead. To every
one of its affiliated clubs should go out a letter advising
them of the housecleaning program and requiring them

to organize at once a housecleaning committee. Where
clubs do not exist the enthusiasm must be stirred up and
transferred into action. This can be done by communi-
cating with the leading automobile people in such sections
through the press.

With the citizens of our State this work should be
looked upon as an investment and not an expense. The
cleaning up of the State will advertise it from one ocean
to the other; the cleaning up of the State will increase
the pride that every resident should have in his State;
this cleaning up will bring tourists to our valleys, our
lakes and our mountain sections who have never been
to them before.

September 1 brings into force one other good law in
New York State, namely, protection to roadside signs
which have for their object warning on steep hills, warn-
ing for sharp and dangerous curves, warning for danger-
ous railroad crossings, as well as ordinary direction signs
to towns and cities. For years there has been much ma-
licious destruction of sign boards erected by the many en-
terprising clubs throughout New York and other States.
To date there has been little hope of hunting down the
offenders. The new law provides for this and when en-
forced will mean thousands of dollars per year to motor-
ing organizations as well as great pleasure to the auto-
mobiling public.

\* \* \*

BACKWARD, TURN BACKWARD

Q UITE a few car owners would to-day like to go
backward to the conditions of five or six years
ago, rather than exert themselves enough to keep pace
with the march of progress in the automobile field. There
are scores of car owners who would like to have the old
single-cylinder motors instead of the four or the six;
there are others who would gladly cast the magneto aside,
supplanting it with the dry cells; others ask for the plane-
tary gearset instead of the selective, and many requests
of similar tone are heard nearly every week.

These expressions come from a general atmosphere
of uncertainty. It pervades so many sections of the in-
dustry. It is due to the evolutionary period through
which we are passing. We have not reached the goal
in any particular department of the motor car. The
pneumatic tire is a marvel, but there are scores who are
looking forward to the invention and manufacture of
some Utopian spring wheel or cushion tire that will give
satisfactory results at much lower cost. Hundreds are
convinced that the ideal in carburetion is yet far off;
and, in fact, carbureter makers are experimenting with
the venturi, the multiple nozzle, waterjacketing and a
score of other things. Nobody is certain to-day whether
the poppet valve is going to remain in the ascendancy
for five years or if the slide-valve motor will usurp its
position, or if some form of rotary valve will win out.
In the contest department the experts are puzzled whether
stock car events or free-for-all races will be the leader in
a couple of years. Some makers are wondering whether
it is better to go into races, reliability runs or other forms
of tests. No wonder buyers wish for Father Time to
turn back the hands. All this unrest is characteristic of
the age; it pervades many other industries to-day, it is
indicative of progress. Were we all contented, were
everything to our liking, we would be miserable; in fact,
we would be through with our usefulness in this world.



# Detroit to Hold Season's First Show

## Big Exhibition at Michigan State Fair

*Full 1912 lines of automobiles, both commercial and pleasure, have been entered for space at the annual exposition, which will be held this year from Sept. 18 to 22. Manufacturing situation is far more favorable this Summer than it was last year and some of the companies are still under high pressure. Poss Company occupies deserted Anhut factory and intends to put out 1200 cars for 1912. The Detroit Automobile Dealers' Association will exhibit during the week of January 22.*

**D**ETROIT, Aug. 21—Detroit motordom is looking forward with great interest to what is likely to be the first comprehensive display of 1912 motor cars to be held anywhere in the United States. Reference is, of course, made to the annual show which takes place in the building particularly constructed for the purpose, on the grounds of the Michigan State Fair. Of course, the dates are coincident with those of the fair, September 18-22.

Every foot of space in "Motor Hall" has been taken and the larger number of the Detroit factories will exhibit, either directly or through their Michigan distributors. In addition, most of the manufacturers of motor cars whose factories are in Michigan, though outside Detroit, will be on hand.

Among the exhibitors will be representatives of the Jackson, Cole, Studebaker Corporation, Rapid, Brush, Poss, Hupmobile, Detroit Motor Wagon Co., Chalmers, Commerce Motor Car Co., Elmore, Hudson, Day Utility, Lion, General Motors, Abbott-Detroit, Cartercar, Regal, Oakland, Everitt, Cadillac, Buick, Overland, Detroit Electric, United Motors, Seitz, Mitchell-Lewis and many others. In each case the exhibitors promise to make displays of the complete lines for the coming year. In many cases the cars will be shown for the first time.

The fair's automobile show has come to be one of its most attractive features. In addition to the motor-wise who come to get their first view at the new designs, there is a large attendance of prospective purchasers who come to make their choice at a place where they have free access to the latest types.

The show has a separate management which, though under the general control of the Fair association, acts independently in conducting the display. Walter Wilmot is the show manager.

Following the sale of his Hupmobile stock by R. C. Hupp, the Hupp Motor Co. has issued the following announcement:

Charles D. Hastings has been appointed general manager of the Hupp Motor Car Co., to succeed R. C. Hupp, who has resigned, to devote his entire attention to other interests. Mr. Hastings has been with the Hupp Motor Car Co. as assistant general manager since its inception and has always been prominently identified in the executive affairs of this company, so that the retirement of Mr. Hupp will in no way affect the plans or policy of the Hupp Motor Car Co.

Mr. Hastings has been identified with the automobile industry since its infancy, having been connected with the Olds Motor Car Co. before the Hupmobile came into the market.

E. A. Nelson, the designer and chief engineer of the Hupp Motor Car Co., to whom is due the credit of the design and motor of the Hupmobile, is at the head of the engineering department of the factory, and the personnel of the officials of the company remains unchanged with the exception of Mr. Hupp's retirement.

The Hupp Motor Car Co. is interested only in the manufacture of the Hupmobile and has no other connection.

Production of 1912 models is in progress at all plants in Detroit at present and, while the rush of getting out demonstrators for the dealers is now over and there is very little night work, general activity is in progress to a much more noticeable extent than a year ago. The Packard is steadily increasing its force and is working at a rate in excess of anything in its history. The firm will shortly come into the possession of additional floor space which will raise its producing area to 37 acres. At present the plant employs 7,000 men and is the largest purchaser of labor in the local field. The firm is now about two weeks behind orders and is working its machine shop at night.

The deserted plant where the Anhut Six was formerly made has been occupied during the past week by the Poss Motor Co., the first car of which participated in the recent *Evening American* run between Detroit and Chicago. It is announced that the concern will produce 1,200 light delivery trucks during the coming year, with a load capacity of from 1,200 to 1,500 pounds.

The Poss is one of the few new concerns to enter the lists this season and, like nearly all of its generation, is a producer of commercial, rather than pleasure, vehicles. A number of new manufacturing concerns have been recently formed to produce parts and equipment, however. Among these are the Auto Lock & Specialty Co., of Detroit, capitalized at \$15,000; the Durable Top Specialty Co., of Detroit, \$15,000; and the Mason Motor Co., of Flint, \$100,000.

The week of January 22 has been selected as the date for the annual show of the Detroit Automobile Dealers' Association. Though no formal announcement has been made, it is probable that the show will again be held in the inadequate Wayne Gardens. This condition last year led to a secession of representatives of forty-five manufacturers who held a separate and competing show at the factory of the Regal Co. In all probability, those crowded out of the Gardens will take some similar action this year, as their show was a great success.

### S. A. E. Adopts Standard Tires

Realizing the advantages to be gained by bringing about a condition of interchangeability between different makes of solid tires the Society of Automobile Engineers has, after considerable investigation, adopted a table of standard tire and wheel dimensions. It was universally acknowledged that it was of mutual advantage to all parties concerned that such a condition of standardization should obtain, but there was considerable work involved in order to determine what the various dimensions should be. The report was finally made, however, last Spring, and the plans of the motor vehicle manufacturers are to put the standards into effect by the beginning of the next calendar year.





Lincoln, No. 24, winner Class 2K, undergoing brake test



Le Moon, No. 23, winner in Class 4K, checked in first at South Bend

## Chicago Truck Run Finished Six Perfect on Road with Buick as Winner

*Of the twenty-six starters in the truck run under the auspices of the Chicago "American," which lasted nine days and was laid out through rough going for two days, twenty-four checked in on time. The cars covered Indiana, Ohio and Michigan and ran on a schedule of from eight to fourteen miles an hour. Despite adverse road conditions the column made a fine showing.*

**C**HICAGO, Aug. 21—On August 17, the nine-day reliability run for commercial vehicles, promoted by the Chicago *Evening American*, ended at the starting point, in Chicago. The route was from Chicago to Detroit, with night stops at South Bend, Fort Wayne, Lima and Toledo; and back by way of Jackson, Kalamazoo and South Bend. The distance covered was 756 miles, with the vehicles running at an average schedule speed of from 8 to 14 miles per hour.

Of the twenty-six vehicles that started in the run, twenty-five finished and twenty-four checked in on time, only one having fallen out on the fourth day as a result of engine trouble. Six out of the twenty-five to finish had perfect scores at the end of the run; but only one of these managed to survive the final technical examinations.

A two-cylinder Buick delivery wagon, with a load of 1500 pounds and driven by F. W. Kunze, was the only perfect score



Group of drivers who participated in the Chicago American's truck run—taken at Jackson, Mich.

FINAL RESULTS CHICAGO EVENING AMERICAN SECOND COMMERCIAL VEHICLE RELIABILITY RUN

No.	Car.	Driver.	Class.	Gallons Gasoline	Pints Oil.	Cost Gasoline.	Cost Oil.	Cost Driver.	Car Depreciation.	Total Cost.	Total Cost per Mile Less Tire.	Depreciation Tires.	Total Cost Mile.	Capacity, Tons.	Cost per Ton Mile.	Total Road Penalties.	Technical Examination Penalties.	Total Penalties.	Total Cost per Ton Mile, including Penalties at 1 of a Cent per Penalty.	Winner	
9	Poss.....	W. F. Trudeau..	2K	With drawn																	
24	Lincoln.....	Chas. Woodrich..		41.	18.25	\$4.92	\$.57	\$22.50	\$1.76	\$29.75	\$.039	.03	.069	.5	.138	4	1	5	\$.143	Winner	
37	Van Dyke.....	H. J. Morrison....		66.5	108.5	7.98	3.38	22.50	3.24	37.10	.049	.03	.079	.5	.158	188	7	195	.353		
5	Modern.....	C. J. Bigelow....	3K	74.5	13.	8.94	.47	22.50	5.22	37.13	.049	.02	.069	.75	.104	26	15	41	.145	Winner	
10	Buick.....	F. W. Kunze.....		44.62	58.5	5.35	1.83	22.50	3.00	32.68	.043	.035	.078	.75	.117	Perf.	15	15	.117		
11	Buick.....	A. Easterday....		52.63	47.5	6.32	1.48	22.50	3.00	33.30	.044	.035	.079	.75	.119	Perf.	15	15	.134		
27	Krickworth..	J. M. Worth.....	4K	57.	38.	6.84	1.19	22.50	4.32	34.85	.046	.02	.066	.75	.099	25	Perf.	25	.124		
31	Chi. Pneu. Tool.	E. W. Aplin.....		77.75	96.5	9.33	3.02	22.50	3.15	38.00	.050	.02	.070	.75	.105	51	86	137	.242		
33	Chase.....	H. L. Ferris....		59.38	24.	7.13	.75	22.50	2.88	33.26	.0439	.02	.064	.75	.096	10	76	86	.182		
1	Gramm.....	A. L. Nobbs.....	5K	97.88	33.	11.75	1.06	22.50	6.75	42.06	.056	.02	.076	1.0	.0756	1492	26	1518	1.594		
6	Hewitt.....	J. W. Gardham..		63.63	51.5	7.64	1.62	22.50	4.68	36.44	.048	.02	.068	1.0	.068	Perf.	26	26	.094		
20	Louth-Juergens.	F. W. Herrick..		71.	25.8	8.52	.80	22.50	6.39	38.21	.051	.02	.071	1.0	.071	69	27	96	.167		
23	Nelson LeMoon.	A. R. LeMoon....	6K	52.	35.	6.24	1.09	22.50	7.20	37.03	.0489	.02	.069	1.0	.0689	Perf.	3	3	.072	Winner	
30	Owosso.....	Wm. Rust.....		88.	17.7	10.50	.56	22.50	6.22	39.78	.0525	.02	.073	1.0	.0725	96	7	103	.176		
34	Chase.....	J. O'Brien.....		69.75	48.	8.37	1.50	22.50	4.59	36.96	.0488	.02	.069	1.0	.0688	8	25	33	.102		
38	Clark.....	McCue.....	7K	90.38	17.5	10.85	.55	22.50	6.66	40.56	.053	.02	.073	1.0	.073	68	12	80	.153		
39	Ideal.....	W. C. Mills....		77.63	198.5	9.32	6.22	22.50	4.23	42.27	.0559	.02	.076	1.0	.0759	7	50	57	.133		
32	Federal.....	R. F. Moore.....		96.88	16.	11.63	.50	29.97	5.47	47.57	.062	.03	.092	1.25	.0736	Perf.	9	9	.083	Winner	
26	Stephenson..	E. H. Zimmer....	8K	108.38	17.5	13.01	.55	29.97	6.20	49.73	.065	.03	.095	1.25	.076	2040	10	2050	2.126	Winner	
36	Gramm.....	A. Withrow.....		117.75	27.5	14.13	.86	29.97	8.38	53.34	.0706	.03	.111	2.0	.055	7	2	9	.064		
13	Mais.....	A. F. Mais.....		115.25	17.	13.83	.53	29.97	10.80	55.13	.0728	.04	.113	2.5	.0451	Perf.	5	5	.050	Winner	
16	Kelly.....	A. E. Rayner....	9K	121.38	36.	14.57	1.13	29.97	9.04	54.71	.0723	.04	.112	2.5	.0449	4	Perf.	4	.049	Winner	
3	Gramm.....	C. A. Haines....		160.15	39.	19.22	1.22	37.53	11.40	69.37	.091	.04	.131	3.0	.0437	1351	4	1355	1.399		
14	Dayton.....	A. H. Bennett....		129.	92.5	15.48	2.36	37.53	10.84	66.21	.087	.04	.127	3.0	.0423	19	27	46	.088		
17	Kelly.....	C. R. Withgott..	9K	126.25	45.5	15.15	1.41	37.53	10.08	64.17	.084	.04	.124	3.5	.0354	3	10	13	.048	Winner	
4	Gramm.....	A. E. Walden....		188.25	62.	22.59	1.94	37.53	14.82	76.88	.1017	.06	.162	5.0	.0323	64	18	82	.114	Winner	

car at the end of the final technical examinations. The six cars, however, that managed to finish with perfect road scores included two Buicks, Hewitt, Nelson-LeMoon, Federal and Mais.

All of the above cars, however, are not winners. In deciding the winner of the tour the cost of operation per ton-mile has been the chief determining factor, while the road penalties and those of the final technical examination have been a minor consideration; it will be found, however, in some instances that the latter assumed the greater proportions in the final score.

As shown in an accompanying table, the cup winners in the respective classes are as follows: Class 2K, No. 24 Lincoln; Class 3K, No. 10 Buick; Class 4K, No. 23, Nelson-LeMoon; Class 5K, No. 32 Federal; Class 6K, No. 2 Gramm; Class 7K, No. 13 Mais; Class 8K, No. 17 Kelly; and Class 9K, No. 4 Gramm.

In promoting this contest, it has been the object of the Chicago Evening American not only to emphasize the superiority of the motor over the horse-drawn vehicle, but also to demonstrate to the purchaser of commercial vehicles the cost of their operation. An accurate record of all the gasoline and oil used by each vehicle throughout the run has been kept by the technical committee, as well as an account of all repairs and adjustments made; and these factors, together with a certain stipulated sum or percentage for tire cost per mile, up-keep cost, and chassis depreciation per annum, have been used to determine the winner of the contest.

In the data collected during this demonstration there is much,

perhaps, that is not to be taken too seriously, because the constants or percentages used to decide the winners are of an arbitrary nature. As yet there is no data on which an absolutely fair percentage of chassis depreciation and tire cost can be based; nor can the reliability of a commercial vehicle be fairly demonstrated in a run of but 756, 1000, or even 2000 miles. Depreciation hardly begins until a vehicle has been run 2000 miles, and then it is not in direct proportion to the mileage, but in an ever-increasing ratio. This ratio, too, is affected to a very great extent by the character of the tires employed.

In this demonstration each of the vehicles was loaded to its catalogued capacity. In all 36 1-2 tons were transported 756 miles on 2247 gallons of gasoline and 148 gallons of lubricating oil.

One error was made in the laying out of the route that greatly affects the final results. For two days the cars were driven through a territory where the roads were in terrible shape, and the conditions were anything but those for which the commercial car is designed. No one would ever consider the use of a commercial car in a country where the roads were impassable, and during these two days all of the larger vehicles in the run were subjected to strains that never would be encountered in any regular service in which a motor vehicle would be practicable. Had it not been for the severe conditions encountered during these two days, a much better fuel and oil economy would have been shown by the heavier vehicles.



Federal, No. 32, winner in Class 5K, climbing Gulch Hill, near Battle Creek



Kelly, No. 17, driven by Withgott, which won in Class 8K, performed well throughout the run

Many gallons of fuel and oil were consumed by those vehicles during the hours that their engines were being strained and raced while pulling each other out of the deep sandy places that allowed the axles to rest on the roadbed.

As for the weaknesses in design and construction that the run brought out in the various contesting vehicles, there were but few, and these for the most part of small importance. The test, however, was a severe one, and those vehicles that did have weak points had them very plainly shown up. It was an excellent means of showing the maker where the weak points lay.

Another important feature was the excessive wear on some of the tire equipment, some of the vehicles having to make several changes, while others of the same weight made no changes and still managed to keep their tires in good shape. The following facts were brought out: Where a car is to be used on country roads where there are ruts to contend with, the tread of the wheels should be standard and the wheels shod with single and not dual tires.

In cases where the tread was wider than standard, it was necessary to drive with the wheels on one side of the car in a rut, while the other wheel would be breaking down the crest on the outside of the other rut, thereby causing excessive power consumption and excessive wear on the one tire and perhaps on both. If dual tires are fitted, and the tread is standard, then both outside tires generally are breaking down the crest of the ruts on either side, and rapid wearing away of the rubber takes place.

### Dorris Wins Missouri Run

St. Louis, Aug. 21—A Dorris car, driven by J. E. Baker, won first place in the touring car class in the four-day reliability run from St. Louis to Kansas City and return, which began Aug. 14 and finished Aug. 17, under the auspices of the St. Louis Automobile Manufacturers' and Dealers' Association. Incidentally the Dorris also carried off the special cup offered by the St. Louis Motor Accessories Association for the car, regardless of class, to finish with the highest score.

A protest was filed against the Ford, which was awarded first honors in the runabout class, on the ground that it did not carry stock equipment. The protest was sustained, and the final award made to the Flanders, which had been penalized two points.

The route followed going to Kansas City was what is known as the Northern Highway, and the return trip was made by way of the Central route, which has just been adopted as the official State Highway. The Inter-State was penalized 50 points for being late at a control, having lost the route. The Parry was penalized for a motor stop due to water getting into the carbureter at a deep ford. The Cadillac was disqualified because the driver misunderstood the rules and worked on his car at noon stop. The Ohio withdrew because of a series of small mishaps, after making a perfect road score for two days. The Hudson was penalized for losing the road, and the Marmon drove 50 miles out of its way and was penalized. Summary:

TOURING CARS.		
Car.	Road Score.	Technical Score.
Dorris	Perfect	Perfect
Marmon	3	Perfect
Mitchell	9	Perfect
Parry	7	5
Interstate	56	8
Hudson	12	53
Buick	53	36
Ohio	Withdrawn	
Cadillac	Disqualified	
ROADSTERS.		
Ford No. 6	Perfect	Protested
Flanders No. 12	Perfect	2
Ford No. 5	35	Perfect
Flanders No. 11	96	2

### Blanks Out for Fairmount Park Race

PHILADELPHIA, Aug. 21—The Quaker City Motor Club on Friday afternoon issued entry blanks for the Fairmount Park 200-mile road race to be held over the 8-mile West Park course at noon on Saturday, October 7.

The placing of the management of this annual classic in the hands of the Quaker City Motor Club ends a contest that has been waging off and on for a period of several months between the Quaker City Motor Club, Mayor Reyburn and the Philadelphia Automobile Trades Association, the latter organization, composed of dealers in gasoline pleasure cars, having some time ago put in a bid for the honor of conducting it.

As in last year's race, cars will be classified in four divisions, 3-C, 231 to 300 cubic inches piston displacement; 4-C, 301 to 450; 5-C, 451 to 600; 6-C, 601 to 750; cars in each of the divisions to compete for division prizes of \$1,000, with a grand prize of \$2,500 for the car making the best time.

The entry list is limited to 30 cars.

### Jerseymen Moving for Reciprocity

SPRING LAKE, N. J., Aug. 21—That the residents of this State are feeling the effects of the restrictive legislation that is keeping the motorists of adjacent commonwealths away was demonstrated at a meeting held here last Saturday, and which was called at the instance of T. Frank Appleby, of the Ocean Boulevard Commission. Many prominent men from all parts of the State were present, and although several items were mentioned in the call for the meeting, it was manifest that the subject nearest the hearts of all was that which had to do with the passage of a law that will insure reciprocal treatment to the auto-

### To Tear Down Signs

*Ugly and puzzling defacements of warning and distance marks on the highways of New York may be destroyed by anyone after Sept. 1 and signs displayed upon highways that are not specifically permitted by the owners of private property may also fall under the axe of anyone who pleases to destroy them. The A. C. A. proposes to make September 1 the day for such destruction.*

"CLEAN-UP DAY" is being strongly advocated by the Good Roads Committee of the Automobile Club of America, meaning that on September 1 when the new law prohibiting the defacement of sign posts, milestones and danger signals to automobilists goes into effect that owners of automobiles shall make it a point to destroy all such defacements.

The accompanying illustrations show how the meaning of a warning to automobilists may be fogged with extraneous matter and the law prescribes that unauthorized signs may be destroyed by anyone.

The section of the law relied upon by the club as its author-



This is the kind of thing that automobilists are asked to put an end to on and after Sept. 1

mobilitists of other States granting similar privileges to motorists of this State.

After a long debate a resolution introduced by J. H. Wood, president of the Associated Automobile Clubs of New Jersey, was finally adopted calling upon the Legislature to pass a reciprocity law at its next session, at the same time providing against any possible reduction of the revenue by urging that the law be so framed as "to show an increase" in receipts.

At the opening of the meeting Mr. Appleby, who is Mayor of Asbury Park, admitted that the motorists were a big factor at all the shore resorts, and that everything possible should be done to attract them. Other speakers who advocated remedial legislation were H. A. Bonnell, general manager of the Automobile Board of Trade; Frederick W. Kelsey and J. C. Anthony. The resolutions as finally adopted read as follows:

"Resolved, That a law be enacted with regard to the use of automobiles within the State which will grant the same rights and privileges to the owners and drivers of machines from other States that are accorded the citizens of New Jersey, in the States from which said owners and drivers hold their licenses: and be it further,

"Resolved, That it is the sense of this meeting that the system of licensing automobile in New Jersey be adjusted so as to show an increase of revenue."

The meeting also passed a resolution favoring the enactment at the next session of the Legislature of a law which shall place the maintenance of "through roads under the direct supervision

---

ity for undertaking the campaign was passed by the recent legislature and is as follows:

"A person who willfully or maliciously displaces, removes, injures or destroys a mile-board, mile-stone, danger sign or signal, or guide sign or post, or any inscription thereon, lawfully within a public highway; or who, in any manner paints, puts or affixes any business or commercial advertisement on or to any stone, tree, fence, stump, pole, building or other structure, which is the property of another, without first obtaining the written consent of such owner thereof, or who in any manner paints, puts or affixes such an advertisement on or to any stone, tree, fence, stump, pole, mile-board, mile-stone, danger-sign, danger-signal, guide-sign guide-post, billboard, building or other structure within the limits of a public highway is guilty of a misdemeanor.\* Any advertisement in or upon a public highway in violation of the provisions of this subdivision may be taken down, removed or destroyed by any one.

"This act shall take effect September 1, 1911."

\*A misdemeanor is punishable by a fine up to \$500 or one year in jail, or both, at the discretion of the Court.



Another instance of the defacement of roadside trees due to pernicious advertising methods

of the State Road Department." At present the various counties and towns are taking care of their respective roads with indifferent success.

A representative delegation of prominent automobilists waited upon Governor Woodrow Wilson, of New Jersey, on Tuesday, seeking his aid to alleviate the peculiar legal situation in Jersey. The party was headed by H. A. Bonnell, general manager of the Automobile Board of Trade, and included J. R. Wood, president of the Associated Clubs; George Blakeslee, Senator Edge and several other leaders in the fight.

The main point discussed was the abrogation of the nauseous Power of Attorney clause and in emphasizing this phase of the matter, Mr. Bonnell on behalf of the delegation submitted to the Governor a copy of last week's issue of THE AUTOMOBILE containing an extended article on the Jersey Chinese Wall which paid particular attention to the objectionable clause.

Governor Wilson accepted the article and assured the committee that he would give it due attention.

## Jersey Farmer Helps

*This being a true incident of an actual experience suffered by an interstate tourist who met with delay and tire trouble and ran short of gasoline. The following story tells just how the Jerseyman rose to the occasion and combined the joys of a kindly act well performed with the chance to make a little hay while the sun did not shine.*

WILMINGTON, DEL., Aug. 21—An interesting story is being told here—and it is true, too—which has got what is commonly known as "Jersey extortion" beat a mile, and it may be a coincidence that it all happened in Jersey.

A few weeks ago George A. Elliott, a prominent local attorney and churchman, went to New York to sail for Europe, with his family, leaving Wilmington the day before he was to sail. After reaching New York he decided to take his touring car abroad and accordingly telephoned to his chauffeur, who was at his house, here, to bring the car to New York and to deliver it by 10 o'clock that night at the Waldorf-Astoria, where the Elliotts were temporarily stopping.

All went well until Trenton was reached, when he had a blow-out. This caused a delay, but was not nearly as serious as the next mishap, when both tubes of one of the tires exploded. After the machine had proceeded a short distance above Trenton.

Nightfall was coming on and just as the machine entered a heavily wooded road the car stopped short and an examination showed that the gasoline was exhausted.

After waiting until about 11 o'clock, and with no hope of any other solution of the problem, the chauffeur set out on foot for the next town, about 2 miles distant, but he was unable to get any gasoline. He was informed, however, that 3 miles further on there was a farmer who had a gasoline engine, and that he might be willing to sell a sufficient quantity.

There was nothing else to do and the chauffeur "hoofed it" to the abode of the aforesaid farmer, whom he finally succeeded in arousing from his slumbers. After the situation was made clear to the sleepy farmer, the latter agreed to let the chauffeur have three gallons of gasoline, and with the gasoline and chauffeur he started in his wagon in the direction of the belated machine, which was reached in due time.

Before the farmer would permit the gasoline to be taken out of his wagon he demanded settlement. There were three gallons and he was asked what he was going to charge for them. "Nine dollars a gallon," was his reply.

"Why you are joking," said the chauffeur.

"No, I'm not," the farmer replied. "You will have to pay me \$27 before that gasoline leaves my wagon. You don't suppose I'm going to get out of my bed and haul oil five miles for nothing. My price is \$9 a gallon, and nothing less."

It cost Mr. Elliott just \$185 to get his car driven over from Wilmington to New York.



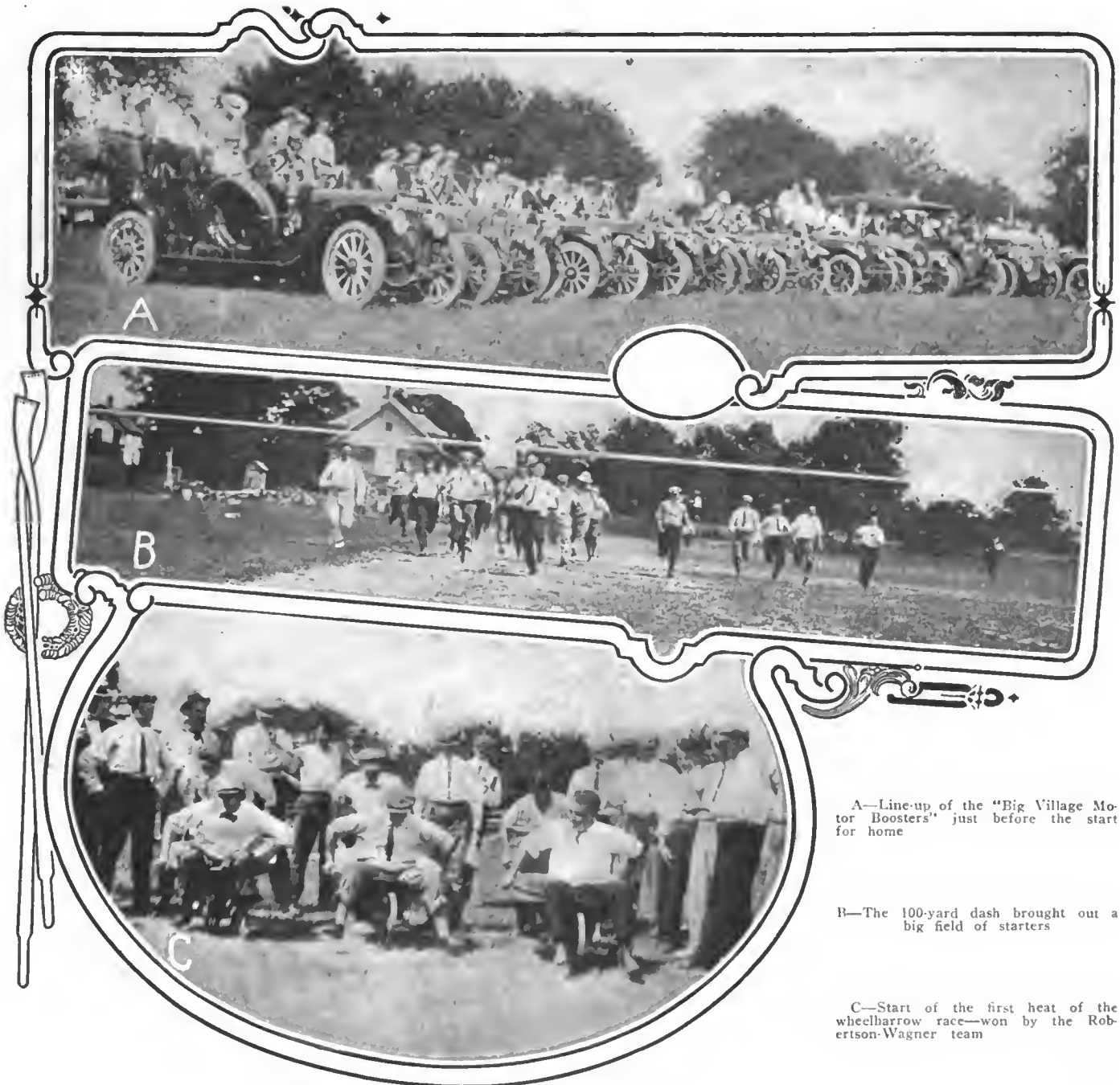

A—Line-up of the "Big Village Motor Boosters" just before the start for home

B—The 100-yard dash brought out a big field of starters

C—Start of the first heat of the wheelbarrow race—won by the Robertson-Wagner team

## Motor Boosters' Picnic

Over 100 men connected with the New York automobile industry in one way or another attended the first annual outing of the organization known as the Big Village Motor Boosters. The affair was held at Smithtown, L. I., and a long semi-athletic program was decided and everybody had a splendid time. The baseball game was a feature of the outing.

SOMETHING over 100 members of New York City's automobile industry answered the call issued by the Big Village Motor Boosters for its first annual outing Wednesday, August 16, at Smithtown, L. I. The bulk of the boosters made the 49-mile run by automobile, reaching Riverside in time for breakfast. The first number on the program after breakfast had been allowed to settle was a baseball game in which everybody but the cripples took part. It is recorded that there were four shortstops on each side. The final score after five innings was 83 to 47, Captain George Robertson's team being on the long end. Horace A. Bonnell, General Man-

ager of the Automobile Board of Trade, acted as umpire of play and escaped practically unscathed.

James E. Sullivan, recently named as a member of the new boxing commission, was to have acted as referee; but owing to the injuries he sustained in a train wreck a few days ago, he was excused and Mr. Bonnell subbed on the job.

The 100-yard dash developed some fast announced time, the time being much faster than anything in the race, as it was discovered afterward that the course was twenty yards short. There was a long program decided embracing every known form of contest and a few that were specially invented for the occasion. The automobile obstacle race, during which the cars were required to make a serpentine course around a series of barrels, was won by a Corbin (W. E. Carney) defeating the bigger and heavier cars around the sharp turns.

There were swimming races and just plain bathing and lots of other amusement for the members.

The whole affair was most enjoyable and throughout there was not an unpleasant incident. The spirit of good fellowship pervaded. At dinner, which wound up the day of pleasure, over





D—Fur flew when the "Mutts" and "Jeffs" met on the baseball field

E—Somebody lost a diamond on the ball field, and a systematic search found it

F—Many of the Boosters found time for a dip in Long Island Sound

100 sat down together. Mrs. Fred J. Wagner provided lunches for the picnickers during the day.

The boosters plan some other variety of function during the Fall and a smoker shortly after the conclusion of the metropolitan show season.

### Score Enter Glidden Tour

Despite the fact that entry blanks for the Glidden Tour of 1911 have been issued only about a week, a score of entries have already been received and more are being received every day. The start of the tour is scheduled to take place at New York, October 15, and the finish will be at Jacksonville, Fla., October 25. The course over which the automobiles will travel will be via Atlanta.

The final clause in the entry blank is causing much interest and not a little comment. It reads as follows: "Inasmuch as the National Tour is a good roads and tourists' tour, without technical examination or technical penalties, it is open to any owner of a bona-fide touring car or runabout and the

Stock Registration Requirement of the rules is hereby waived."

The contestants will run in teams of three, not necessarily of the same make or year, and the award will be made to the city represented by the team accumulating the least number of demerits.

So far the entry list comprises the following: 1912 Flanders, C. E. Winn, Atlanta; 1912 White, J. S. Cohen, Atlanta; 1910 Chalmers, J. H. Marsteller, Roanoke, Va.; Oldsmobile, Dr. W. N. Stinson, Jacksonville, Fla.; Cadillac, Claude N. Nolan, Jacksonville, Fla.; Garford, R. P. Hooper, Philadelphia; 1912 Maxwell, U. S. Motor Co., New York; 1912 Maxwell, U. S. Motor Co., New York; 1912 Maxwell, U. S. Motor Co., New York; 1911 Pierce-Arrow, E. P. Ansley, Atlanta; 1912 Stevens-Duryea, C. H. Johnson, Atlanta; 1911 Marmon, H. M. Grant, Atlanta; 1912 White, J. S. Cohen, Atlanta; 1911 Cole, H. B. Race, Jacksonville; 1911 Cadillac, O. S. Albritton, Jacksonville; 1912 Cadillac, W. J. Hillman, Live Oak, Fla.; 1912 Cunningham, A. H. Whiting, New York; 1912 Reo, Ray M. Owen, New York; 1912 Reo, Ray M. Owen, New York; 1910 Knox, W. C. Aycoc, Moultrie, Ga.

# NEWS OF THE WEEK CONDENSED



RAMBLER SALESMEN GATHERED AT THE KENOSHA, WIS., FACTORY FOR THE ANNUAL CONVENTION

Top Row—G. M. Berry, M. Mattson, C. D. Hagerty, A. L. Stapleton, G. R. Sutherland, Al. Reeke, E. J. Wall, A. R. Rockwell, C. S. Culp, B. F. Spencer, O. Murphy, G. H. Cox, H. F. Lantz, G. Braithwaite. Second Row—W. F. Portwine, J. M. Gaffney, R. S. Bennett, C. Sldarek; C. A. Baker, J. K. Bond, F. E. Devlin, Gilbert Williams; F. C. Mock, J. O. McDonald, J. A. Rose, W. C. Burbank, E. S. Jordan, J. P. Zens, R. Jardine. Third Row—O. G. Formhals, E. G. Soward, H. H. Maddock, F. W. Rosche, T. D. Cobbs, Jr., G. B. Owens, H. E. Tanner, F. C. Bacon, W. S. Simonds, L. A. Poundstone, W. H. Knight, T. B. Long, I. J. Kinnett, L. E. Rood, R. C. Chase, C. D. Dunham, C. M. LeRoux, G. D. Racine, Z. C. Elkins, H. G. Musgrave, H. P. Thompson. Fourth Row—J. W. DeCou, M. E. Lebon, E. E. Herring, W. E. Wissler, G. C. Norwood, S. S. Jenkins, I. R. Campbell, C. T. Jeffery, E. J. Leach, W. G. Schultz, H. M. McEachren, P. J. Keating, C. O. Hart, G. A. Ruckert, P. D. Carman, L. P. Kilbourne, G. N. Bliss.

**NEWARK, N. J.**—Forty applications were acted upon at the August meeting of the trustees of the New Jersey Automobile and Motor Club last Tuesday, bringing the membership total close to the 2,500 mark. *The Club Bugle*, the official organ, made its first appearance last week.

**PITTSBURGH**—The newly organized Chamber of Commerce at Sharon, Pa., through its chairman, H. H. Cohen, announces that Sharon has secured a big automobile factory on which work will be started within sixty days. The plant may afford employment to 2,000 hands and the company, which is now being organized, it is stated, will have a capital of \$250,000.

**COLUMBUS, O.**—The announcement is made that the Eastern Automobile Company, recently incorporated with a capital of \$20,000, has taken over the garage and repair shop formerly operated by the L. & E. Garage & Sales Company at 60-62 East Spring street, Columbus, Ohio. J. Goldstein is president; J. E. Leacy, secretary and F. F. Cain, general manager.

**PITTSBURGH**—Edward M. Bigelow, of Pittsburgh, State Road Commissioner of Pennsylvania, recently appointed by Governor John K. Tener, announces that work will be started shortly on a 50-mile thoroughfare to extend from Gettysburg and by the historic battlefield to the Pennsylvania State line. He plans to have the road entirely finished by the time the grand reunion is held in Gettysburg.

**TOLEDO, O.**—The new club house of the Willys-Overland employees, located at Bay Shore, Toledo, is furnishing much diver-

sion this summer. One of the latest functions was a dance given by the girls from the top and trim departments. The Overland band furnished music for the dancers. About forty young women employed at the plant attended.

**DES MOINES**—The Des Moines Automobile Association will hold an automobile show in connection with the Iowa State Fair, which is to be held in the last week in August at the State Fair Grounds. Practically all the dealers in the city have reserved space, and the affair will be second in importance only to the annual Winter Automobile Show. A feature of the show is to be a floral parade, which will be the first of the kind ever held in Des Moines.

**RACINE, Wis.**—George Williams, superintendent of the motor department of the J. I. Case Threshing Machine Co., Racine, Wis., whose resignation was announced a short time ago, will on Sept. 1 become factory manager of the King Motor Co. of Detroit, in which he holds an interest. On leaving Racine Mr. Williams was tendered a banquet by the foremen and employees and was made the recipient of many valuable gifts, including a watch suitably inscribed, a set of cuff links and a studded watch charm.

**PITTSBURGH**—The American Rubber & Fabric Company gave a demonstration of its puncture-proof tire on Grant street last week. A car equipped with its tires and heavily laden was run over a plank from which protruded 100 sharpened spikes extending out from one to two inches. Although the spikes penetrated

the rubber shoe of the tire they did not puncture the fabric lining. The American Company has secured a location at Jeanette, Pa., on the main line of the P. R. R.

**HARTFORD, Wis.**—Work on the addition to the works of the Kissel Motor Car Co. of Hartford, Wis., has been started. The building will have dimensions of 107 x 200 feet and will be three stories high, with 12 and 14 foot ceilings, of solid brick construction. Contracts have also been awarded for the construction of an addition to the machine shop, to be 50 x 112 feet in size. It is hoped to have both structures ready by Nov. 15 or Dec. 1, as the big Kissel works are now cramped for room and the enlargement of the output for 1912 makes more manufacturing space essential.

**GRAND RAPIDS, MICH.**—W. R. Link and Fred Hicks are promoters for a new industry, the purpose of which will be the refinishing of automobiles. Mr. Hicks at present is connected with the Adams & Hart company in the capacity of contractor for the refinishing business and he is an experienced workman. He will manage the factory end of the business, and Mr. Link, who is quite well known in the city, will have charge of the offices and publicity branch. The company will be incorporated for about \$30,000, it is expected, and a new two-story building will be erected for its accommodation.

**ST. LOUIS**—The Central Route, which follows in a general way the old Boone's Lick road and the Santa Fé trail, has been designated the official Missouri State Highway by the State Board of Agriculture, on con-



dition that satisfactory progress is indicated in the improvement of the roads within the next few weeks. Governor Hadley and members of the Automobile Club of St. Louis recently made a motor car trip over the road selected in an effort to choose a State highway. The road is to be opened with appropriate ceremonies, including an automobile tour, about Oct. 15, according to present plans.

IRVINGTON-ON-HUDSON—The New York branch of the Locomobile Company of America has just delivered a combination chemical and hose automobile of 40 horsepower to the village of Irvington-on-Hudson.

NEW YORK—Byrne, Kingston & Co., makers of the Kingston carbureter, have established a metropolitan branch office in the Buick building, 1733 Broadway. The former headquarters of the concern were at 1650 Broadway.

LOS ANGELES—Brown-Symonds Co., 1140 S. Olive street, have taken on the agency for the Stutz car, built by the Ideal Motor Car Co., Indianapolis, Indiana. They expect to enter one of these cars in the Santa Monica road race.

PITTSBURGH—J. Eugene Beck, with offices in the Jenkins Arcade building, has secured the agency of the Midland line of automobiles manufactured by the Midland Automobile Company of Moline, Ill. It will have four models, including a two-passenger runabout of 40 horsepower and a seven-passenger 60 horsepower.

BROOKLYN—E. J. Montigny, owner of the Plaza Garage, Bedford avenue, near Bergen street, who was formerly agent for the Abbott-Detroit, has closed a contract with the Ideal Motor Car Co., of Indianapolis, Indiana, for the sale of Stutz cars in Brooklyn and Long Island. He expects to receive his first demonstrating car the early part of September.

BUFFALO—The firm of Baker Bros., Geneva, N. Y., and E. H. Green, Cole 30-40 distributors, have consolidated under the firm name of Baker Bros. Motor Car Company. The firm have taken quarters

at 846 Main street, Buffalo. Baker Bros. will continue to sell Cole cars in Geneva. This branch being under the direction of Clarence Baker, E. H. Baker and E. H. Green will handle the Buffalo business.

SEABROOK, N. H.—This town possesses the star motorists' trap. An automobilist who pleads guilty is "let off" with a \$5 fine, to which is incidentally added "costs" of \$1 apiece for each constable who is on the job (there are usually three or four besides the complainant, who gets \$1.62 for his extra exertions), \$1.38 to the judge who hears the case, \$1 to the State secretary, \$5 to the State treasurer. Steep as is this total, it is usually cheaper than pleading not guilty, for in this instance the luckless motorist, if found guilty, is mulcted to the tune of \$25, besides the expense of traveling to New Hampshire to attend court.

WASHINGTON, D. C.—A bill to establish a Federal Highways Commission, whose duties it shall be to urge the co-operation and joint action of the several States with the Federal Government in the construction, improvement, and maintenance of permanent and durable highways throughout the United States, prescribe such rules of agreement in connection with their use as will insure uniform and equitable highway regulations, and issue Federal licenses governing interstate automobile travel or commerce, was introduced by Representative Linthicum August 16 and was referred to the Committee on Interstate and Foreign Commerce and ordered to be printed.

WILMINGTON, DEL.—A week's successful service, performing with satisfaction the work of four horses and two wagons, has convinced the Police Department heads of Wilmington that they made no mistake in adopting a motor patrol wagon and relegating the horse-drawn vehicles. Basing his calculations on the experience of the past week and his knowledge of automobiles, Chief of Police Black believes the automobile now in use here, a six-cylinder 40 horsepower Pierce-Arrow, will pay for itself and the garage in which it is housed and which was built by the city expressly

for it, within the next two or three years. The machine, which was bought through the local agency of the Foss-Hughes Co., with the equipment, represents an outlay of about \$3,500, while the garage, which is on city property, cost \$1,000.

BALTIMORE, MD.—Sign posting on the road between Baltimore and Annapolis has been completed by the Automobile Club of Maryland under the supervision of Secretary H. M. Luzius. This is in line with the pledge made at a recent meeting of the club to complete as soon as possible the posting of all roads leading into Baltimore within a radius of ten miles. Work will soon be started on the Frederick, Washington, Hagerstown and York roads. Secretary Luzius and his workers made the trip over the State highway, eight miles of which he says is in excellently improved condition, having been newly laid. Through the courtesy of the Mar-Del Mobile Company, local representatives, a Packard delivery wagon was used for carrying the signs, post tools, workers, etc., while Secretary Luzius used his Cadillac car in directing the work.

FOND DU LAC, WIS.—A résumé of conditions in the motor car field at Fond du Lac, Wis., discloses facts that are regarded as typical of similar cities in Wisconsin. Local sales agents sold approximately 165 cars from Jan. 1 to Aug. 15. Of this number 39 cars were purchased by residents of Fond du Lac, about fifty were sold to farmers and the remainder in a small territory surrounding Fond du Lac. The average price of the cars was \$1,250, which is about 20 per cent. lower than the average for the preceding year, and indicates the trend of the trade at this time. There is also a change of the base of the market. Formerly the agent sought city buyers and did not attempt to interest the farmers. To-day the farmers are the sought and the seeking and are taking the larger percentage of the total sales. The city trade practically takes care of itself and requires no particular effort on the part of the agent. Fond du Lac is a city of upwards of 17,000 population.



Three-load Universal motor trucks recently sold to a big brewing firm in Detroit



**INDIANAPOLIS, IND.**—Will H. Brown, president of the Mais Motor Truck Company, came to the rescue of charity workers here with an original method of getting crowds out to a fair for the benefit of a fresh air mission. Mr. Brown had a cannon built and mounted on a truck. Advertising cards telling about the fair were loaded in the cannon and by a strong spring trigger attachment, they were shot forth along the streets into the crowds as the truck was driven all over the city. A bugler rode on the seat with the driver and gave a "military" atmosphere to the "stunt."

**NEW YORK**—A. O'Donnell has been promoted manager of the New York office of the Booth Demountable Rim Company.

**SAN FRANCISCO**—The Abbott-Detroit "Bulldog" has now covered 31,000 miles in its contemplated journey of 100,000 miles.

**LOS ANGELES**—The Chanslor and Lyon Co. has announced that it has taken the agency for the Pacific Coast of the Kelly-Racine tire.

**DETROIT**—The Packard Motor Car Company announces that recently the company shipped thirty cars and ten trucks from the factory.

**ST. LOUIS**—The agency for St. Louis for Cook's Auto Transmission Lubricant has been placed with the Marine Supply Co.

**GALION, O.**—W. E. Dunston has been appointed general manager of the Ditwiler Mfg. Co., manufacturing the Ditwiler steering gear and other products.

**CLEVELAND**—W. S. Eaton, formerly superintendent for Jas. Cunningham, Son & Co., Rochester, N. Y., has accepted a position with the White Co., Cleveland, O.

**BERNARDSVILLE, N. J.**—Bernardsville Fire Co. has appointed a committee to look after the purchasing of a motor-driven pump automobile with 1,000 feet of hose.

**OCONTO, WIS.**—Frank Smith and H. N. Bradley have formed a partnership and will build a garage and repair shop on Superior street.

**HUDSON, WIS.**—The Hudson Garage Co. has been incorporated and chartered with an authorized capital of \$10,000. The promoters are Emil E. Meyer, W. M. Grant and Chrs. Nickelby.

**NEW YORK**—After a trip of 2,536 miles the touring Commer truck has returned to New York. The company announces that the average gasoline consumption was one gallon to 7.1 miles.

**PITTSBURGH, PA.**—The Vulcan Motor Supply Company has been organized by Frank H. Seely, Jr., J. G. Tite and H. T. Slater at Altoona, Pa., and will do a general automobile business.

**HARTFORD, CONN.**—The C. W. Kelsey Mfg. Co., makers of the Motorette, announce that this name has been duly registered as a trade mark under Patent Office Trade Mark registration 52,764.

**BOSTON, MASS.**—The Commer truck is the latest to secure an agency in Boston, having been taken on by the Dodge Motor Vehicle Company, that also handles the Pope-Hartford and the Waverley electric.

**CLEVELAND**—W. F. Melhuish, formerly sales manager of the Croxton-Keeton Company, has been appointed manager of the sales department of the White taxicab.

**NEW YORK**—C. A. Mezger, Inc., announces that the prices of Soot Proof spark plugs will probably be reduced this fall. If such action is taken, the company states that sales after Sept. 1 will be promoted.

**SAN FRANCISCO**—The Pioneer Automobile Company has secured the agency in Northern California for the Commer truck and Guy Vaughan car, representing Wyckoff, Church & Partridge, Inc., of New York.

**BELOIT, WIS.**—J. H. Saris, agent for the Ford in Beloit and surrounding territory, has leased the former Broadway Skating Rink building and will remodel it for garage and salesroom purposes. The building is 130 by 49 feet in size.

**SHEBOYGAN, WIS.**—The Erie Garage, North Ninth street, owned and conducted by H. E. Smith, has been purchased by Harry Black and I. E. Clarenbach. Extensive improvements will be made. The Erie Garage was the first in Sheboygan.

**PITTSBURGH**—The Kittanning Motor & Transfer Company is a new concern at Kittanning, the capital of the coke region, formed by G. H. Burns, J. S. Claypool, Roy M. Cox, D. L. Schaffer and D. E. Aceland of that place. The company's capital is \$5,000.

**PITTSBURGH**—The Bessemer Motor Truck Company has been formed at Grove City, Pa., by I. M. Louis, A. M. Allen, L. M. Monroe, J. E. Marshall, E. J. Fithian and W. H. Shellits of that place. It will have a large garage and several important agencies.

**MILWAUKEE, WIS.**—The Kopmeier Motor Car Co., 375-389 Summitt avenue, Milwaukee, Wis., has closed a contract for exclusive representation in the State of Wisconsin for three years of the Fiat car. The Kopmeier company is distributor of the Chalmers and Detroit Electric lines.

**ST. LOUIS**—The Brooks-Latta Company, which now has an experimental plant at 4255 Fairfax avenue, has secured an option on a lot with a frontage of 200 feet at Sullivan and Lambdin avenues, on which it is planned to build in the near future a factory for the manufacture of motor cars and delivery wagons.

**NASHVILLE, TENN.**—The Hager Elliott Engineering Company has opened a garage in connection with its large machine and repair shops on McGavock street. The new building has 24,000 square feet of floor surface and is the home of the Peerless, Velie, Empire and Paige-Detroit.

**OSHKOSH, WIS.**—The Crane Taxicab Co.'s building at Fifth and Wisconsin streets was badly damaged by a wind and rain storm. Preparations had been made for a large addition, and the excavations weakened one of the side walls. A new structure will now be erected on the same site.

**TOLEDO, O.**—The new home of the Roberts Toledo Automobile Company is rapidly nearing completion and will be ready for occupancy early in the fall. It is located at the corner of Madison and Eleventh streets, Toledo, and will face sixty feet on Automobile row. The first floor will be used as a display and salesroom and the second floor for repairs. A modern freight elevator will be installed.

**WORM-DRIVE AND COMPENSATING GEAR**—This gearset consists of a bevel gearing system driven by means of a gear and worm.

3. Fig. 1 shows the combination of a pair of aligned axle sections A A, bevel gears B B secured to the inner ends of these sections, and a worm gear G G mounted co-axially with respect to these sections and containing a spider frame S. One or more journal pins extend radially in the spider frame, each pin having a key slot in its outer end, with keys in them and extending into corresponding slots in the worm gear. A planetary pinion journaled on each pin meshes with the gears on the respective section of the axle shaft, a pair of housing sections H H encloses gears and pinions and turns with the spider. The housing sections are journaled on the gear hubs. A gear casing surrounds the axle sections, enclosing also the worm-gear and the housing sections. A worm W is journaled in the gear casing and meshes with the worm gear G G. Roller bearings placed between gear casing and housing sections hold the latter in position.

No. 999,876—to David E. Ross, Brookston, Ind., assignor to the Ross Gear & Tool Co., La Fayette, Ind.; granted August 8, 1911; filed December 16, 1908.

**Nut Lock**—Being a specially constructed device, consisting of the elements described as follows.

This patent relates to the combination of a lock with a nut and bolt and a washer provided with a relatively thin portion having parallel grooves extending from its outer periphery. A central upstanding boss having vertically extending passages is provided, the passages communicating with the grooves referred to, which are parallel with the bolt opening in the nut. A locking pin has legs adapted to be forced along the grooves, which abut against a rear arched wall at the upper end of the passages in the boss, whereby the legs are deflected downwardly through the vertically extending passages in the boss. The tight portion of the locking pin is so bent as to engage the adjacent sides of the nut.

No. 999,842—to Carl Emil Nielson, Madera, Mexico; granted August 8, 1911; filed July 30, 1910.

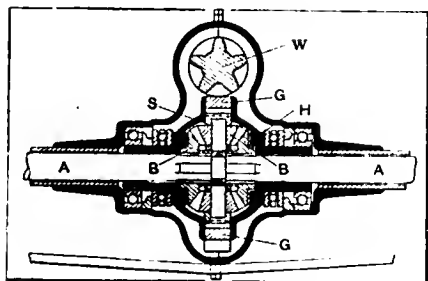

Fig. 1—The Ross Worm Drive and Compensating Gearset



**SAND DISTRIBUTING VEHICLE**—A construction intended to carry and distribute sand or like material.

1. The patent refers to a vehicle with a hopper mounted on the same and two feed-wheels charged from the hopper with the material. The wheels are connected by a flexible cross member. On each feedwheel shaft is mounted a main friction wheel engaging an auxiliary friction wheel. To an oscillatory shaft are journaled a pair of spring-urged intermediate friction wheels, one of these wheels being adapted to engage one of the main wheels and the other intermediate wheel to engage with the auxiliary friction wheel. A driving friction wheel is provided which engages with one intermediate wheel while the other intermediate wheel engages with the auxiliary friction wheel.

1,000,004—to Werner Huber, Sihlbrugg, Switzerland; granted August 8, 1911; filed August 24, 1910.

**ADJUSTABLE ELECTRIC LAMP**—This is a construction in which the lamp may be adjusted relatively to the reflector of the headlight.

1. The headlight shown in Fig. 2 comprises a lamp with closed back B, a para-

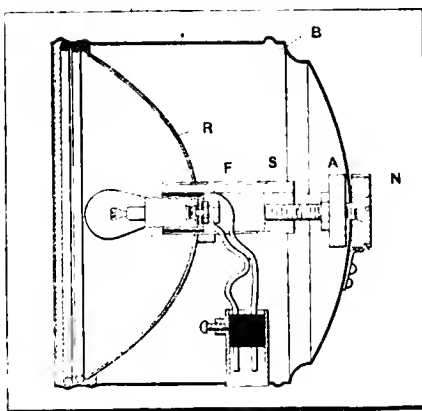

Fig. 2—Perry Electric Light with adjustable lamp socket

bolic reflector R therein and a short flange F integral with it. The non-rotatable sleeve S extends through the flange and may be moved inwardly or outwardly through the office of an axial screw shaft A actuated by an adjusting nut N, whereby the position of the plug holding the source of light relatively to the lamp reflector is altered.

No. 999,860—to Ward S. Perry and Julius O. Eis, Chicago, Ill., assignors to Vesta Accumulator Co., Chicago, Ill.; granted August 8, 1911; filed November 15, 1909.

**INTERNAL COMBUSTION ENGINE**—This patent covers the combination of two opposed cylinders with an interposed crankchamber and connections thereof to the cylinder spaces, the engine operating on the two-stroke cycle.

1. The engine illustrated in Fig. 3 is a combination of two oppositely arranged cylinder castings having an interposed crankcase, the walls of the cylinders having a longitudinal passage each, connecting the combustion chambers with the crankchamber by means of an inlet port. The pistons reciprocating in the cylinders open and close the inlet ports mentioned alternately. On the opposite side of the cylinder wall outlet ports communicating with exhaust passages are provided, which are also alternately opened and closed by the movements of the reciprocating engine pistons.

No. 1,000,128—to George F. Swain, Chicago, Ill.; granted August 8, 1911; filed January 28, 1909.

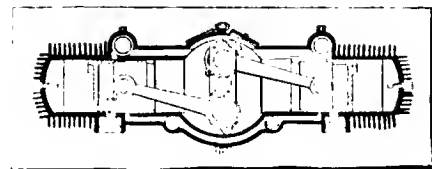

Fig. 3—Swain two-stroke cycle engine with opposed cylinders



## Seen in the Show Window

**E**XHAUST horns utilize the pressure of the hot gases expelled by the motor, permitting the gases to by-pass from their regular path and to flow through a pipe or whistle, where the sound is produced. The Autolarm horn which seen at CA is placed between the motor and the muffler, a butterfly serving to close the way of the gases to the silencer and directing them to the pipe. Owing to its position the signal can neither clog nor jar loose. The material of which this signal is made is fully able to withstand the deteriorating influence of the motor exhaust, and especially because of the protected location of the horn the metal will not be attacked during its time of service, even if this should last as long as the life of the car the signal is installed upon. Operation of the signal is by means of a pedal arranged on the footboard in front of the driver, this pedal being connected to the signal proper through suitable wiring. It is made by the Gray-Hawley Manufacturing Company, 607 West Fort street, Detroit, Mich.

**A**S an example of a compressed-gas tank which will permit the chauffeur to keep the tires full of gas at all times the "Improved Baby" tank is shown at CB. It is filled with carbonic acid gas under a high pressure, the carbon dioxide being filled into the tank when in the liquid state. If the outlet is opened the "carbonic" gasifies and expands into the tire. The tank is made of steel of great strength, thus being capable to hold the gas under the high pressure obtaining in the vessel, which is more than 200 pounds per square inch. To inflate a tire, the hose connection is pressed against the tire valve and the valve at the end of the tank, controlling the outflow of the compressed gas, is opened by turning the nut seen in the illustration. Thereby, the carbonic acid gas is permitted to flow into the tube until the gauge attached to the tank indicates the desired tire pressure. Then a turn of the valve nut in the opposite direction closes the tank tightly. The "Baby" holds 4 pounds of gas all of which may be utilized in pumping up the tires of the automobile on which the carbonic-acid tank is installed, which is the product of the Liquid Carbonic Company, 432 Wells street, Chicago, Ill.

**T**HE type of valve reseater shown at CC is being made by G. F. Crone, of 332 Genesee street, Buffalo, N. Y. It is, in a way, similar to a milling machine

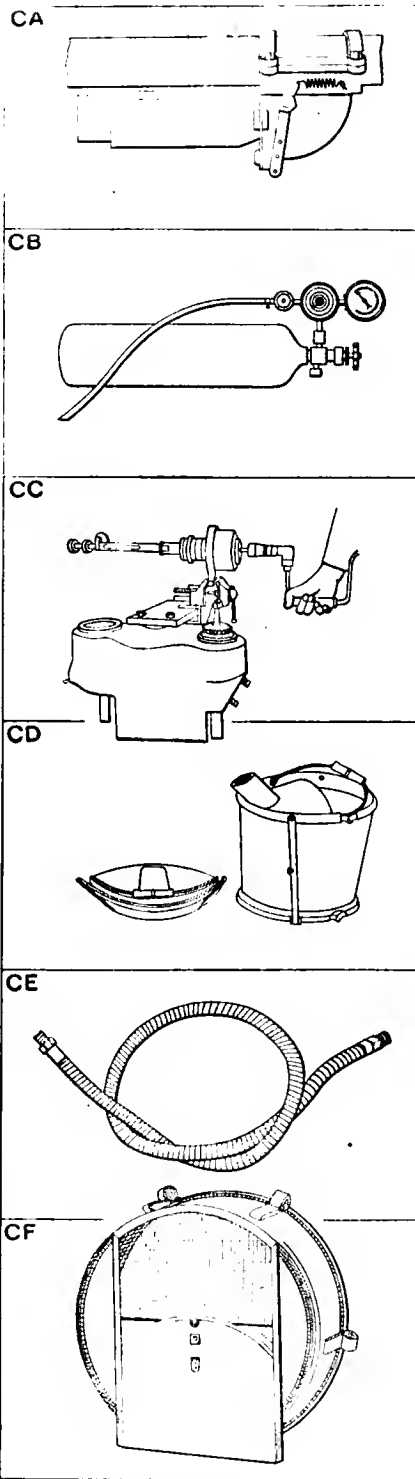

CA—Gray-Hawley autolarm horn utilizes the exhaust gases of the engine  
 CB—The Improved Baby gas tank contains four pounds of carbonic acid  
 CC—The Crone valve reseater is built along milling machine lines  
 CD—Duplex folding pail is handy and waterproof and contains a strainer  
 CE—Almond flexible steel tubing may be used for many purposes on a car  
 CF—Ajax sliding door tire trunk for keeping tubes separately and protected

cutter, and cuts out the valve seat in the cylinder besides serving to true up the face of the valve. A brace operates the tools performing this work. The machine here illustrated is of a novel type, and contains an improvement in the shape of a vise holder which is fastened to the cylinder head while the face of the valve is worked upon.

**A** WATER pail which is collapsible so that it may be transported in the tool box and also provided with a screen to keep foreign substances out of the vessel into which the water is poured, is the description of the useful accessory shown at CD, this being the Duplex Folding Pail. The left-hand view shows the pail in the collapsed state and the right-hand one ready for use; the skeleton of the pail is of elastic metal bands and the material of the pail itself perfectly waterproof. This handy vessel is manufactured and sold by the Planet Company, located at 170 North Elm street, Westfield, Mass.

**U**NITING great strength with elasticity, steel tubing is fully on a par with flexible brass tubes, and the absolute absence of rigidity is seen at CE, where the Almond Flexible Tube is shown. This connection is of steel, and will render good service to connect carbureter and gasoline tank, gas tank and headlights, or the oil reservoir and the oil pump on an automobile. The T. R. Almond Manufacturing Company, of 1 Maple avenue, Ashburnham, Mass., is the maker of this article.

**F**OR transporting spare tire tubes on an automobile when touring, the tire trunk illustrated in Fig. CF may be used. It is made of a metal body covered with weather-proof fabric which serves equally well to preserve the tires in spite of the violent heat of the Summer sun and from oil which would otherwise spill over them through the carelessness of a driver. The trunk is strapped to the body of the car and is opened and closed by sliding down and up the door which is able to travel in a guideway. Thus the tubes are kept in a place by themselves, where they cannot be damaged by any tools or like apparatus; nor is there any danger of the tires being stolen from the trunk, because a lock of reliable make insures the owner against the intrusions of any interloper of the road. The trunk here shown is the product of the Ajax Trunk and Sample Case Company, of 91-93 Mercer street, New York City.

# THE AUTOMOBILE

## Records Fall at Elgin Stock Races National, Mercer and Abbott-Detroit the Winners

*Fast time featured the two days' racing over the Elgin, Ill., 8.5-mile course, where the 1911 National Stock Car championships were decided on Friday and Saturday, August 25 and 26. With the exception of the race for 161 to 230 cubic inch displacement cars the times showed a marked reduction over those of last year.*



THE NATIONAL No. 2, DRIVEN BY LEN ZENDEL, CROSSING THE TAPE IN THE LEAD IN THE BIG RACE FOR THE ELGIN CUP

CHICAGO, Aug. 28—Four new champions were evolved from the running of the National Stock Chassis road races at Elgin, when National 2 (Zengel), National 1 (Herr), Mercer 15 (Hughes), and Abbott-Detroit, 33 (Roberts), received the magpie flag first in their classes. New marks were made in three of the four contests and the lap record of the course was sharply lowered by the Lozier entry (Mulford).

Shortly after the start of Saturday's contest, the Elgin National, ten sections of the grandstand collapsed, causing intense confusion and excitement for a short time and necessitating a new start. Fortunately no fatalities attended this mishap, although probably fifty persons were more or less hurt. The cars were sent on their way after fifty minutes of delay and within a few rounds several of the cars that had been prominent in prac-

tice were off the course for one reason or another and the race settled into a long grind to the finish. It was an easy victory for the National, with the Alco second, pushed out to the limit to beat the Mercer to the wire.

Over 40,000 witnessed the first day's events, which were run simultaneously, and on Saturday the crowd was estimated at 80,000. The manner in which the course was protected through-

per hour of Mulford, last year's winner. In the Illinois, Herr in the National, went the 202 miles at an average rate of speed of 65.6 miles per hour, and of the four that started only the two Nationals caught the eyes of the judges. The Kane County brought out the biggest field of the meet, eleven of the sixteen entries starting and seven of them finishing, with Hughes showing an average of about 63 miles an hour. The Aurora cup



2—Line up of contestants in the Elgin Cup race, which took place on the last day

3—General view of the competing cars at the pits preparatory to Friday's races

4—Lozier, driven by Mulford, on the round in which it broke the lap record

5—The troops were taken to their stations on the course in motor trucks

6—Mercer won the Kane County Cup and finished third in the Elgin

out the races, and the attention to detail reflected great credit upon the Chicago Motor Club, which managed the racing end of the program.

In a nutshell this tells the story of a meet that rivaled in excitement any that ever has been run in this section. As to the racing end of it, there was little competition in the four events, and only in the Illinois was the finish at all close, and in that it was a case of two teammates fighting for the cup and being separated by but 9 seconds. The Kane County event seemed made to the order of Hughie Hughes, who never was threatened, while in the Aurora Kulick in the Ford, which finished second, never was much of a factor. In the big race the early elimination of most of the stars robbed that classic of its chief interest, although not until Zengel flashed across the tape for the last time was it certain the cup was his. Grant and Hughes were so close to him that a stop of any duration in the final stages might have changed the result. In this race the contest feature was the fight for second place between Grant in the Alco and Hughes in the Mercer and at the end a matter of but 11 seconds separated the two.

Ten of the twelve entrants in the Elgin National started and of these only three were caught by the judges, while there still was one running when the race was officially ended. Zengel, the winner, averaged 66.45 miles per hour as against the 62.5 miles

brought out all three of its entries and all three finished, with Roberts in the Abbott-Detroit averaging 53.5 miles per hour.

The accidents that tended to mar the meet, came the second day, although the first was not without its mishaps. On Friday, F. E. Radina, mechanic for Raimey, in the Cino, in the Kane County, suffered a broken ankle, while Robillard, driver of one of the Stavers, had a close call when he hit a telegraph pole, cutting it down. But it was the second day that was blackest and that there wasn't a long death roll as the result of the falling of a section of the grandstand, was a marvel. The day started most auspiciously—weather made to order, immense crowds and intense interest among the spectators who filled the stand to its capacity of 6,600. The ten candidates for the national honors had come to the tape, had been lined up and sent away on their 305-mile run when the accident occurred.

Grant was about due to show above the crest of Britten's hill, just west of the stand, and the spectators stood up to watch him come over the brink. Then came the crash. Possibly the swaying caused by so many people standing at once started the trouble. The west section started to fall, or rather drop, the next followed suit and like a house of cards the western quarter of the stand went to the ground. It wasn't a terrifying sight to watch, either, for the fall was so gradual that one hardly appreciated the gravity of the situation. The spectators for the

most part were so pinned in that they couldn't jump had they wanted to, and the big majority simply sat in their seats and waited for the inevitable. There wasn't must confusion about it, either, and the people in the east end of the stand hardly knew anything had happened.

In all, probably 600 people fell with the stand and of these only forty were treated by the physicians who were on duty. The most serious injury was a broken leg sustained by one of the women spectators from Valparaiso, Ind., although three others had fractures that sent them to the hospital, one of the three being the daughter-in-law of Senator Lorimer. Probably fifty others were bruised or shocked, but none of them so badly that the physicians had to be called on.

No official statement has as yet been given out as to the cause of the fall of the stand, but it is presumed that it was a case of too much haste in erecting the seats. The stand was a part of the big stadium used for Chicago's recent aviation meet and was used at Elgin last year. The aviation meet extending one day longer than had been scheduled because of the benefit given last Monday, the contractor was delayed in getting it to Elgin. In fact, he still had his men working on it when darkness came Thursday night and it was not until Saturday morning that he had put the awnings over the boxes. The Chicago Motor Club had nothing at all to do with the erection of the stands or with

they be held there until the officials could learn more about the accident. That this was a wise act was apparent to all, for if the race had continued there might have been more trouble, especially in trying to get the injured to the hospital. Only one lap had been run so no one's chances had been injured. For the most part the drivers backed up the officials and Mulford and Wishart even went so far as to offer to help take the injured to the hospital. However, this was not necessary, the ambulance service being sufficient for the needs of the occasion.

It was nearly an hour later before the second start was made, Grant in No. 1 Alco getting his signal at 11:50. Nine other followed him, the two absentees being the Cinos, one of which was put out in practice on Thursday when a broken connecting rod punched a hole in the crankcase. This caused Raimey to take Burt's place in the other Cino in the Kane County on Friday, but his accident in that race so damaged the car that it was impossible for it to line up with the others in the big event. This left Grant, Lee and Hartman in the Alcos, De Palma and Wishart in Simplexes, Aitken and Zengel in Nationals, Mulford in the Lozier, Buck in the Pope-Hartford and Hughes in the Mercer.

Right from the jump Mulford assumed the aggressive and from the way he burned up the course it looked as if he would repeat his last year's performance. He immediately opened a gap

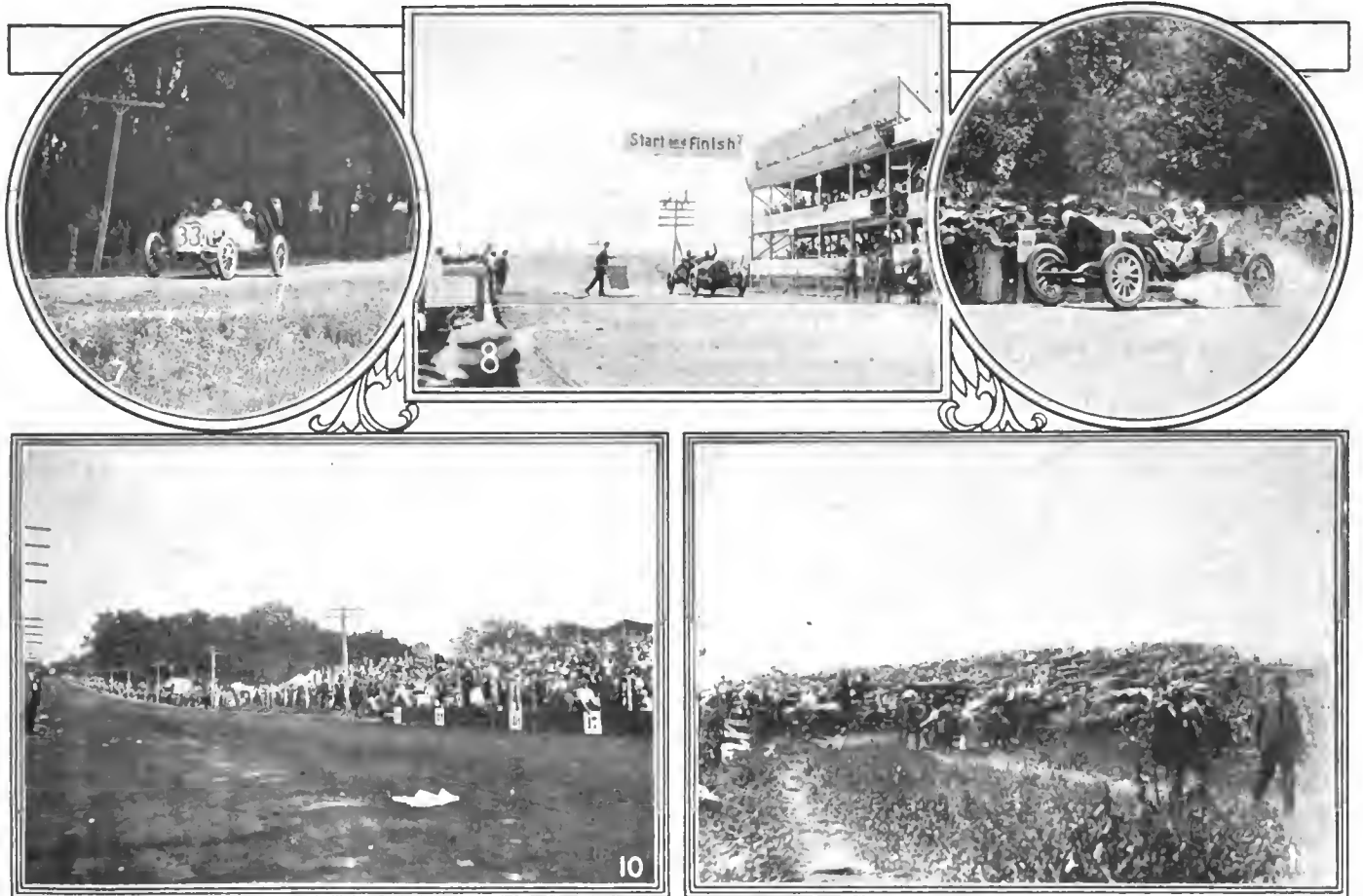

7—Abbott-Detroit, piloted by Roberts, which car won the Aurora Cup race      8—Mercer, No. 15, receiving the flag on the first day, winning the Kane County race      9—A bit of fast work by Herr in the National, which won the Illinois Cup  
10—Giving an idea of the home stretch beyond the stand, and what a clear course means      11—Britton's Hill, a natural grandstand, which accommodated thousands on both days

the receipts therefrom, that coming under the jurisdiction of the Elgin Automobile Road Race Association.

The fact that the race had started added to the general confusion, but the officials at once became masters of the situation. Referee Becroft and Chairman Butler of the A. A. A. Contest board, at once ordered the race stopped, and one by one the cars were flagged and lined up at the pits. It was ordered that

on the others traveling at a rate of 70 miles an hour. This he kept up for eight laps or 68 miles, when a burnt-out bearing put a piston and connecting rod out of commission and stopped the Lozier just at a time when its chances looked brightest. Mulford had one consolation, however, he pulled down the \$200 cash prize given by the Stromberg Motor Devices Co. for the fastest lap. This came in the seventh round, which he negotiated in



Looking west from the top of the press stand—Britton's Hill on the right; showing Zengel's National at a 70-mile clip

7:13, equal to 70.4 miles per hour. His running was most consistent, his laps being 7:27, 7:14, 7:19, 7:17, 7:18, 7:17, 7:13 and 7:17—an average of 69.78 miles per hour for the distance he traveled.

Before this, however, there were others to fall by the way. On his third lap Aitken in the National went out with a cracked cylinder and the big blue car pulled up at the pit. In the same lap another star was eliminated when De Palma was put out with a broken flywheel. Close on the heels of these two mishaps came trouble for Wishart in the other Simplex, a burnt-out connecting rod bearing putting him out of the running when he was in second place. Then the race ran along to the twentieth lap before Hartman in the Alco was put out by a leaky gasoline line. At that time he was in fifth place.

All this time Buck was having tire troubles, much as did George Robertson a year ago in the Simplex. Even though the big Pope seemed to have plenty of speed the continual stops for tires put it out of the running. It was while Buck was fighting to make up some of this lost ground and perhaps get in for a position at the finish that the accident occurred on the back stretch. It was in his twenty-fifth lap and the big car was running over a fine stretch of road. The right front tire went and the Pope turned over completely and came up on its wheels again. Both Buck and mechanic Jacobs were hurled from the car. The mechanic was killed instantly but it was thought for a time that Buck's most serious injury was a broken thigh. He was taken to the hospital, where it developed that in addition his spine was broken and at 5:50 the end came.

While all this was going on Zengel, Grant and Hughes were battling for the cup. Lee and Hartman in the other Alcos never were important factors, but it did look for a time as if Grant might overtake Zengel. The Fairmount Park winner, however, was not to be denied. He kept everlastingly at it, never gave his rivals the least opening and from the time Mulford was eliminated to the end he always was in command. At the end of the twenty-first lap Zengel made his first stop, pulling up at the pit to take on gasoline. The next time around Grant came in and put on gasoline and water. Then the two again went at it hammer and tongs and at the thirty-second lap both made stops at the pit. Zengel took on a small quantity of gasoline,

having heard a rattle in the tank that led him to believe his fuel was running low. This was not so, however, and he picked up the running again immediately. Hughes in the Mercer never stopped at the pits, but he did make one tire change along the course which did not take him long to accomplish.

The last lap was made interesting only by the fight for second place between Grant and Hughes. The Mercer went the last circuit 1 second faster than did the Alco, but that was not enough to land the place. Lee still was running and was in his thirty-third lap when Starter Wagner declared the race at an end.

The first day's racing was marked by the fact that all three winners—Herr, Hughes and Roberts—went through without a stop and also by the freedom from tire troubles, it being reported from the tire camps that only three cars suffered in this respect—two Stavers and Jenkins' Cole. The Stavers pinched tubes through not having racing rims, it is said. Not only did Herr go through without a falter, but Merz, his team mate, duplicated this feat. Merz was beaten 9 seconds for the cup and part of this loss is explained by his overrunning turns three times. Each time this meant a slight loss of which Herr took advantage. Merz often came by the stand at a tremendous clip and he testified to the great speed of the course by stating that several times he had the speedometer needle up to 100 miles an hour coming down the grade from Britton's hill to the stand. In this race the Stromberg \$100 cash prize for the fastest lap was won by Herr, whose second lap in 7:23 was the best.

It was in the Kane County that the chief interest was shown, caused by the large field of starters. While Hughes was looked on as the favorite from the start, still it was thought he would have to fight to beat the Colbys, Coles and the others. The Staver people had hard luck in this. In the first place they were robbed by their best driver when Joe Nikrent, the Californian, was unable to start through having broken a belt in his engine base. Then Robillard went out when he hit a telegraph pole. This left only Monckmeier and that plucky youth kept plugging away and was the last one to catch the flag.

Of the eleven that started in this race, seven finished. Robillard went out in the seventh, as explained. Ogren, a new man in one of the Colbys, was eliminated by having his pistons seize



in the sixth lap. Armstrong, another Colbyite, was running in his fifteenth lap when the race ended. The fourth car was the Cino, which was put out in the seventh lap when Raimey's tire trouble in the backstretch caused the Cino to pitch them both out. Raimey was somewhat bruised and mechanic Radina broke an ankle. Hughes' sixteenth lap in 7:41 won the Stromberg \$100 prize.

Roberts, in the Abbott-Detroit, drove a pretty race for the Aurora cup, although in the early stages it looked as if A. M. Robbins, the Abbott dealer, who was driving his first race, would win. Robbins had gained the lead and was in front at the end of the third lap. In the backstretch a bolt in his magneto coupling broke and he lost 9 minutes fixing it. That lost him the lead. Later on another bolt loosened and more time was lost. These were the only bits of trouble experienced by the three contestants throughout the race. None of them stopped for tires or for supplies. Kulick ran consistently but never got close enough to Roberts to worry him. Roberts' fourth lap in 9:00.19 was the fastest and captured the Stromberg prize.

The time made in all four races was a revelation and the fact that three course records were broken is sufficient reward for the Elginites, who spent \$6,000 on the homestretch alone. In the big race Zengel averaged 66.45 miles per hour for the 305 miles, whereas last year Mulford did 62.5 for the same distance. It is more than likely that even this would have been beaten had Mulford stayed in Saturday, for while he was running he was going but a fraction less than 70 miles an hour. Zengel's consistent work was in keeping with the schedule he had laid out and possibly he could have done better had he been pushed. The Mercer's average in the big race was 64.54 miles an hour.

In the Illinois cup race Herr did 65.6 for the 202 miles, a big increase over last year's Illinois, in which Livingstone, in a National, averaged 60.6 miles an hour. In the Kane County Hughes averaged 63 miles an hour for the 169 miles, whereas last year Buck in the Marmon won at 55.1 miles per hour. Hearne in the Benz won the Fox River cup last year at 54.1 miles per hour, which was just a shade better than Roberts did Friday, the Abbott's average being 53.5 miles per hour.

The manner in which the Chicago Motor Club handled the races was beyond any criticism—there wasn't a hitch anywhere. The guarding of the course was in keeping with the record made by the Illinois citizen-soldiery at Elgin last year and at Crown Point the year before. At all times the crowds were under perfect control and even when the grandstand fell there was no confusion or running across the course. The first day, perhaps, more soldiers could have been used but on the second day there were enough militiamen from the First Illinois Cavalry to give them complete command of the situation.

The timing and checking were first class. The Warner instrument was used in the timers' stand and not once did it slip a cog. There were eleven bulletin boards around the course on which the time was posted and so perfect did L. R. Campbell have his system working the second day that 70 seconds after a car crossed the tape at the finish of a lap the time was on all the boards around the course. The score boards were something new and those in the grandstand had a fine opportunity to study the scheme evolved by H. N. Fowler of the Chicago Motor Club. This big board was worked from behind. Under each car's number was a swinging board, pivoted in the center. The scorers placed the time on this board when it was turned to the rear by means of clips, the figures being already printed on cardboard. Then by swinging this little door it was turned to the front and the public could study the results easily.

The transportation of the soldiers and flagmen was handled by John H. Kelly, who had at his command several big trucks loaned by Chicago dealers, and there never was a hitch there. J. S. Woodworth again handled the flagmen, all of whom were motorcyclists, and this department worked with exceeding smoothness. As for the press stand that was a commodious structure, two stories high. The Chicago newspapers had the first floor and each paper was allowed three representatives there. Upstairs were located the visiting newspaper men and the trade press. There were three rows of seats on each floor, each raised above the one in front so that everyone could see without having to stand up. This stand was filled with more than 200 newspaper men. The publicity department furnished them with all the times and in addition secured official details of all the happenings along the course.



Showing the Elgin course where it leads over the brow of Britton's Hill down toward the grandstand

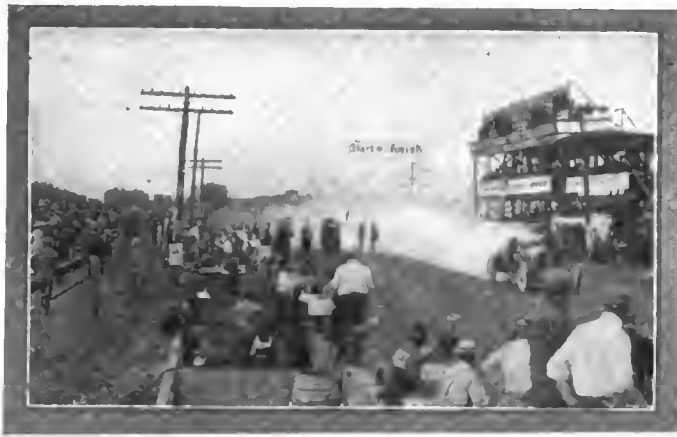

View of the line of pits in front of the main grandstand



National (Zengel) leading Alco (Grant) in making the Hoornbeck's turn



Alco (Grant) and National (Aitken) on the new turn west of grandstand

Another innovation introduced by the Chicago Motor Club was a distinguished guests' stand in which were placed prominent car manufacturers and others whom the club desired to honor. This stand was well filled on both days and the makers appeared to appreciate the compliment, this being the first time those in the industry who are responsible for the racing have been specially cared for at big meets.

A coroner's inquest was held Saturday night in Elgin and the jury returned a verdict holding no one responsible for the death of Dave Buck. "Dave" appears to have been a nickname given the Pope-Hartford driver. His right name was Richard Dudley Buck and he was 36 years old, his birthplace being Buchanan, Mich. Jacobs, the mechanic, was a chauffeur for J. L. Russell, the Chicago agent for the Pope-Hartford, who entered the car in the race.

RESULTS OF THE RACE FOR THE KANE COUNTY TROPHY FOR CARS OF FROM

Car.—Driver.	Lap No.	1	2	3	4	5	6	7	8
MERCER	Elap. Time		15:55	23:42	31:28	39:14	47:03	54:55	62:49
Hughes	Lap Time	7:50	8:05	7:47	7:46	7:46	7:49	7:52	7:54
MERCER	Elap. Time		16:18	24:24	32:33	40:38	48:41	56:36	64:41
Barnes	Lap Time	8:12	8:06	8:09	8:09	8:05	8:03	7:55	8:05
COLBY	Elap. Time		16:59	25:24	33:48	42:06	50:19	58:33	66:57
Pearce	Lap Time	8:35	8:24	9:05	8:24	8:18	8:13	8:14	8:24
COLE	Elap. Time		17:02	25:27	33:52	42:16	50:37	59:04	67:32
Jenkins	Lap Time	8:40	8:22	8:25	8:25	8:24	8:21	8:27	8:28
CORBIN	Elap. Time		16:24	24:34	32:42	40:49	49:05	57:12	65:30
Maisonville	Lap Time	8:15	8:09	8:10	8:08	8:07	8:16	8:07	8:18
COLE	Elap. Time		21:58	30:44	39:12	47:40	56:08	65:05	73:59
Morris	Lap Time	8:47	13:11	8:46	8:24	8:28	8:28	8:57	8:54
STAVAR-CHI.	Elap. Time		16:40	24:47	32:50	40:55	49:32	57:51	66:17
Monckmeier	Lap Time	8:29	8:11	8:07	8:03	8:00	8:42	8:19	8:26
COLBY	Elap. Time		22:42	33:43	46:24	60:29	71:01	84:11	106:56
Armstrong	Lap Time	11:53	10:49	11:01	12:41	14:05	10:32	13:10	22:45
CINO	Elap. Time		17:36	31:04	40:26	49:21	58:08	67:03	
Raimey	Lap Time	8:57	8:39	13:28	9:22	8:55	8:47	8:55	
STAVAR-CHI.	Elap. Time		22:58	31:52	40:50	49:39	59:34	68:46	
Robillard	Lap Time	14:02	8:56	8:54	8:58	8:49	9:55	9:12	
COLBY	Elap. Time		24:56	34:03	43:14	52:37			
Ogren	Lap Time	15:41	9:15	9:07	9:11	9:23			

RESULTS OF RACE FOR ILLINOIS TROPHY FOR CARS OF FROM 301 TO 450 CUBIC INCHES DISPLACEMENT. 24 LAPS (203 MILES, 1596 FEET).

Car.—Driver.	1	2	3	4	5	6	7	8	9	10	11	12	13	14	15	16	17	18	19	20	
NATIONAL	Elap. time	15:00	22:41	30:40	38:25	46:08	53:47	61:23	69:09	77:09	85:11	92:58	100:43	108:31	116:16	124:01	131:42	139:22	147:03	154:45	
Herr	Lap. time	7:37	7:23	7:41	7:59	7:45	7:43	7:39	7:36	7:46	8:00	8:02	7:47	7:45	7:48	7:45	7:41	7:40	7:41	7:42	
NATIONAL	Elap. time	15:28	23:03	30:39	38:18	46:03	53:37	61:16	69:21	77:51	86:04	94:01	101:37	109:08	116:36	124:16	132:05	139:56	147:39	155:10	
Merz	Lap. time	7:46	7:42	7:35	7:36	7:39	7:45	7:34	7:39	8:05	8:30	8:13	7:57	7:36	7:31	7:28	7:40	7:49	7:51	7:43	
VELIE	Elap. time	21:40	31:18	40:27	49:32	58:33	67:39	76:53	85:56	95:07	106:51	116:02	124:54	133:51	142:39	151:30	160:27	169:20	178:10	186:59	
Jeffkins	Lap. time	9:14	12:26	9:38	9:09	9:05	9:01	9:06	9:14	9:03	9:11	11:44	9:11	8:52	8:48	8:51	8:57	8:53	8:50	8:49	
VELIE	Elap. time	16:27	30:08	43:56	57:12	70:33	83:41	96:49	110:02	123:19	136:33	149:48	162:56	176:04	189:11	202:18	215:24	228:29	241:33	254:36	
Stickney	Lap. time	8:26	8:01	13:41	31:48	8:16	8:21	8:04	8:08	8:13	8:07	8:23	18:36	8:17	8:03	8:18	8:05	8:15	Still running		

Herr, National No. 1 fast lap 2nd. 7:23.

TABLE SHOWING THE STANDING OF EACH OF THE CONTESTING CARS WHICH STARTED IN THE RACE FOR THE

Car.—Driver.	Lap No.	1	2	3	4	5	6	7	8	9	10	11	12	13	14	15
NATIONAL	Elapsed time	15:07	22:33	30:27	37:53	45:17	52:48	60:20	67:50	75:16	82:46	90:24	97:57	105:29	113:07	
Len Zengel	Lap time	7:28	7:26	7:54	7:26	7:24	7:31	7:32	7:30	7:26	7:30	7:38	7:33	7:32	7:38	
ALCO	Elapsed time	15:23	22:58	30:35	38:13	45:52	53:35	61:21	69:06	76:50	84:25	92:00	99:35	107:18	115:02	
Harry F. Grant	Lap time	7:40	7:35	7:37	7:38	7:39	7:43	7:46	7:45	7:44	7:45	7:35	7:35	7:43	7:44	
MERCER	Elapsed time	15:44	23:27	31:09	38:53	46:35	54:18	62:00	69:52	77:40	85:29	93:12	101:02	108:58	116:51	
Hugh Hughes	Lap time	7:46	7:43	7:42	7:44	7:42	7:43	7:42	7:52	7:48	7:49	9:23	7:47	7:49	7:48	
ALCO	Elapsed time	18:46	26:44	34:40	42:37	50:33	58:53	68:31	76:27	84:25	93:13	101:34	110:06	118:06	127:00	134:47
Frank Lee	Lap time	10:34	7:58	7:56	7:57	8:16	8:01	9:38	7:56	7:58	8:48	16:21	9:32	7:54	7:47	
POPE-HARTFORD	Elapsed time	25:53	38:08	56:20	74:29	83:22	91:08	99:19	110:22	118:26	126:15	134:10	147:36	156:33	164:31	
Dave Buck	Lap time	16:45	12:15	18:12	18:09	8:53	7:46	8:11	11:03	8:04	7:49	7:55	13:26	8:57	7:58	
ALCO	Elapsed time	15:41	23:29	31:16	39:06	46:53	54:40	62:26	70:15	78:01	85:48	93:35	101:23	109:12	117:11	
Harry Hartman	Lap time	7:45	7:48	7:47	7:50	7:47	7:47	7:46	7:49	7:46	7:47	7:47	7:48	7:49	7:59	
LOZIER	Elapsed time	14:41	22:00	29:17	36:35	43:52	51:05	58:22	Out—Cracked cylinder.							
Ralph Mulford	Lap time	7:27	7:14	7:19	7:17	7:18	7:17	7:13	7:17							
SIMPLEX	Elapsed time	15:11	22:42	30:15	Out—Broken connecting rod.											
Spencer Wishart	Lap time	7:39	7:32	7:31	7:33											
SIMPLEX	Elapsed time	15:21	Out—Flywheel broken.													
Ralph De Palma	Lap time	7:41	7:40													
NATIONAL	Elapsed time	20:23	Out—Burnt out connecting rod bearing.													
John D. Aitken	Lap time	11:38	8:45													



Zengel stopping at the pits to replenish his gasoline supply

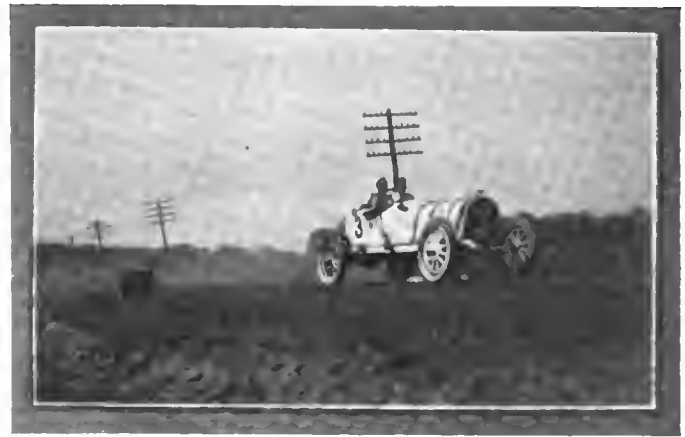

Buck in Pope-Hartford in full flight a minute before the fatal accident

## How the Races Were Won

### Illinois Trophy

Two Nationals and a pair of Velies were the only contestants in this event. The first time around the Herr National had gained 9 seconds on its teammate followed by Velie No. 4, with the Jeffkins Velie, well up, in the rear. At the end of the second round the Herr National, with one of the fastest



Some of the officials who so successfully managed the Elgin races

**231 TO 300 CUBIC INCHES DISPLACEMENT. 20 LAPS (159 MILES, 2460 FEET).**

9	10	11	12	13	14	15	16	17	18	19	20
70:51	78:49	86:52	94:45	102:46	110:46	118:36	126:17	134:00	141:46	149:37	157:21
8:02	7:58	8:03	7:53	8:01	8:00	7:50	7:41	7:43	7:46	7:51	7:44
72:50	80:51	88:55	96:46	104:44	112:42	120:33	128:30	136:23	144:15	152:04	159:55
8:09	8:01	8:04	7:51	7:58	7:58	7:51	7:57	7:53	7:52	7:49	7:51
75:11	83:29	91:42	99:56	108:12	116:37	124:58	133:15	141:46	149:58	158:05	166:11
8:14	8:18	8:13	8:14	8:16	8:25	8:21	8:17	8:31	8:12	8:07	8:06
76:00	84:33	93:00	101:24	109:47	118:09	126:28	134:47	143:05	151:27	159:50	168:19
8:28	8:33	8:27	8:24	8:23	8:22	8:19	8:19	8:18	8:22	8:23	8:29
74:15	85:53	102:08	110:19	118:39	126:48	135:22	143:32	151:46	160:04	168:18	177:12
8:45	11:38	16:15	8:11	8:20	8:09	8:34	8:10	8:14	8:18	8:14	8:54
82:58	91:40	100:18	109:05	117:42	126:13	134:44	143:20	151:50	160:24	168:56	177:37
8:59	8:42	8:38	8:47	8:37	8:31	8:31	8:36	8:30	8:34	8:32	8:41
84:47	93:03	101:22	109:37	118:08	126:29	134:46	145:09	153:33	161:51	170:05	178:16
8:30	8:16	8:19	8:15	8:31	8:21	8:17	10:23	8:24	8:18	8:14	8:11
120:40	133:46	148:18	160:33	171:53	183:09	15:					
13:44	13:06	14:32	12:15	11:20	11:16						

laps of the race, swung into the lead, Merz falling into second place, the Stickney Velie and its mate following in the order named. This order was maintained throughout the third lap, at the conclusion of which Herr was leading his teammate by 22 seconds, with the Velie pair far behind. The conclusion of the fourth round saw Merz leading Herr by the smallest possible margin, with the rest of the field maintaining their respective

**RESULTS OF RACE FOR AURORA TROPHY FOR CARS OF FROM 161 TO 230 CUBIC INCHES DISPLACEMENT. 16 LAPS (135 m., 3024 ft.).**

21	22	23	24	Car.—Driver.	1	2	3	4	5	6	7	8	9	10	11	12	13	14	15	16	
162:26	170:05	177:55	185:55	ABBOTT-DET. Elap. time	18:23	28:32	37:32	48:42	55:54	65:05	74:37	84:01	93:11	102:40	112:28	122:05	131:42	141:23	151:11.32		
7:41	7:39	7:50	8:00	Mort. Roberts Lap. time	9:13	9:10	10:09	9:00	9:10	9:12	9:11	9:32	9:24	9:10	9:29	9:48	9:37	9:37	9:41	9:48	
162:53	170:40	178:22	186:04	ABBOTT-DET. Elap. time	18:58	28:15	47:26	60:04	69:23	78:44	88:11	97:36	106:51	116:14	125:34	134:51	144:39	154:01	166:56.52		
7:43	7:47	7:42	7:42	A. M. Robbins Lap. time	9:37	9:19	9:17	19:11	12:38	9:17	9:21	9:27	9:25	9:15	9:23	9:20	9:17	9:48	9:22	12:55	
			Still running.	FORD Elap. time	19:53	29:38	39:31	49:27	59:20	69:10	79:11	88:56	98:57	109:00	118:59	129:04	139:08	149:08	159:11.53		
				F. Kulick Lap. time	10:02	9:51	9:45	9:53	9:56	9:53	9:50	10:01	9:45	10:01	10:03	9:59	10:05	10:04	10:00	10:03	

**ELGIN NATIONAL TROPHY FOR CARS UNDER 600 INCHES DISPLACEMENT. 36 LAPS (306 MILES, 204 FEET).**

16	17	18	19	20	21	22	23	24	25	26	27	28	29	30	31	32	33	34	35	36
120:42	128:21	135:57	143:31	151:02	159:30	167:13	174:44	182:17	189:55	197:31	265:09	212:50	220:29	228:12	235:49	244:16	252:08	259:54	267:44	275:39.08
7:35	7:39	7:36	7:34	7:31	8:28	7:43	7:31	7:33	7:38	7:36	7:38	7:41	7:39	7:43	7:39	8:27	7:52	7:46	7:50	7:55
122:45	130:31	138:09	145:38	153:14	160:51	170:44	178:25	186:15	193:55	201:39	209:24	217:10	224:52	232:37	240:25	250:42	258:33	266:25	274:14	281:58.72
7:43	7:46	7:38	7:29	7:36	7:37	9:53	7:41	7:50	7:40	7:44	7:45	7:46	7:42	7:45	7:48	10:17	7:51	7:51	7:50	7:44.72
126:25	134:09	141:54	149:40	157:27	165:16	173:03	182:01	189:46	197:34	205:14	212:55	220:32	228:09	235:43	243:30	251:07	258:49	266:41	274:26	282:08.97
8:09	7:44	7:45	7:46	7:47	7:49	7:47	8:58	7:45	7:48	7:40	7:41	7:37	7:37	7:34	7:47	7:37	7:42	7:52	7:45	7:43.97
142:34	150:21	158:09	170:14	178:14	186:28	194:28	205:14	213:09	225:38	233:34	241:19	249:22	257:18	265:24	273:41	285:45.15				
7:47	7:47	7:48	12:05	8:00	8:14	8:00	10:46	7:55	12:29	7:56	7:45	8:03	7:56	8:06	8:17	12:04.15				
172:43	183:31	191:19	199:07	206:58	214:49	222:42	230:33	238:36												
8:12	10:48	7:48	7:48	7:51	7:51	7:53	7:51	7:53												
128:42	136:34	144:24	153:51	163:44																
11:31	7:52	7:50	9:27	11:53																

Turned over on the back stretch.  
Out—Leak in gasoline line.

positions. This order was maintained throughout the fifth, sixth, seventh and eighth rounds. The end of the last named circuit found the Merz National leading by the meager margin of 7 seconds. This lead was overcome in the following round by Herr, who led at the conclusion of the ninth round with a margin of 12 seconds over the Merz National, with the Velie pair still falling back.

From this point on the race developed into a duel between the National pair for the honors, Herr in the tenth round increasing his lead to 42 seconds, to 53 seconds at the conclusion of the eleventh lap and to 63 seconds at the end of the twelfth round. In the thirteenth and fourteenth circuits Merz reduced his teammate's lead by a few seconds and was slowly but surely closing up the gap that separated him from the leader. The conclusion of round fifteen saw the Herr National leading by but a scant 20 seconds, which was still further reduced at the end of the sixteenth lap to 15 seconds. The Herr National gained slightly on the Merz car in the seventeenth, eighteenth and nineteenth rounds, but lost a trifle on the twentieth, Herr's lead at the conclusion of that lap being an even 25 seconds. Rounds twenty-one and twenty-two found Herr hanging on to his meager advantage with bulldog tenacity, the small margin of 35 seconds being all that separated the blue pair.

At this point Merz began a determined effort to overtake his mate, gaining 8 seconds on the next to the last round. When the times of the contending pair had been taken at this point it was seen that the Herr National had a lead of but 27 seconds and Merz went out to cut that down if possible. Herr was equally insistent on maintaining his advantage, and although Merz steadily but none the less surely gained ground he was unable to overcome the lead of his opponent. At the start of the race the Herr National had been sent away 30 seconds in advance of the National No. 3 and thousands of watches were flashed in the effort to keep tab on the flying pair. When Herr crossed the line in 1:55.55, thousands of glasses were leveled at the course to watch for the appearance of National No. 3 over the brow of Britton's hill. Slowly the seconds ticked off and just as 30 seconds had elapsed the blue bonnet of No. 3 shot into sight and came down the stretch at express speed, too late, however to win the race, Merz falling short of the goal by a scant 9 seconds.

Although the Velie pair was still running at the conclusion of the race, No. 2 had completed but 20 laps and No. 4 but 16.

### Kane County Trophy

Eleven of the sixteen cars originally entered in the race for the Kane County cup faced the starter, the three Falcars having been withdrawn and the Staver-Chicago No. 16 and Cino No. 26 having been prevented from starting by accidents in practice earlier in the week. Mercer No. 15, driven by Hughie Hughes, jumped into the lead at once, gaining a substantial lead in the first lap over Cole No. 24 driven by Jenkins, which led Corbin No. 14 by a scant second, with Cino No. 11 close up and the Barnes Mercer trailing along behind the Cino. At the end of the second lap, however, Hughes' teammate swung into second position, being but 23 seconds behind the leader, the Corbin still maintaining third position, Staver-Chicago No. 27 moving up to fourth, Colby No. 20 into fifth and Cole No. 24 dropping back into the sixth notch. These relative positions of the contestants were maintained until the conclusion of the ninth round, Colby No. 18 having meanwhile dropped out at the sixth lap with a seized piston, Fred Robillard in a Staver-Chicago No. 25, coming to grief on the following lap when his car cut down a telegraph pole on the Hoornbeck turn as a result of a tire coming loose, and Ramey, in a Cino, also being eliminated when his car skidded on the backstretch, breaking his mechanic's leg.

The conclusion of the tenth circuit found the Hughes Mercer leading its teammate by 2 minutes, 2 seconds, Colby No. 20 being over 2 minutes behind the Barnes Mercer and Cole No. 24 about a minute behind Colby No. 20. For round after round the Mercer pair added to their lead over the other contestants,

Hughes maintaining an advantage of about 2 minutes over his teammate throughout. From the sixteenth lap on to the finish Hughes gained steadily and the conclusion of the race showed him with an advantage of 2 minutes 34 seconds over Barnes, who in turn was 6 minutes 16 seconds ahead of Colby No. 20, which led Cole 24 by 2 minutes 8 seconds. Corbin No. 14, Cole No. 21 and Staver-Chicago No. 27, all completed the entire 20 laps, the latter being about 20 minutes behind the leader. Colby No. 22 was still running at the conclusion of the race, but was nearly 6 laps behind.

The performance of the leaders was remarkable for the almost entire absence of trouble of any kind, neither of the Mercer pair having been compelled to stop either at the pits or on the course for any reason.

### Aurora Trophy

There were but three entries in the race for the Aurora cup, Ford No. 32, driven by Kulick, being opposed by a pair of Abbott-Detroits—No. 3, driven by Mortimer and No. 31 by Robbins. At the end of the first round Roberts, who had started 30 seconds behind his teammate, had almost overtaken him, crossing the tape the first time around but 4 seconds behind and overcoming the 15-second start of the Ford on the backstretch. The second round saw Roberts with a clear lead of 35 seconds over Robbins, with the Ford almost a minute behind. On the third round Roberts was compelled to stop at the pits and Robbins swung into the lead having an advantage of 17 seconds at the close of the lap. Roberts, however, soon regained the lead owing to the combination of a fast lap and magneto trouble experienced by his teammate on the backstretch. A repetition of the same trouble on the fifth lap caused Robbins to lose still more ground, his place as runner-up having been assumed by the Ford at the conclusion of the fourth round, from which point the order was Abbott-Detroit 33, Ford 32 and Abbott-Detroit 31 to the end of the race. With each succeeding lap Roberts added about 1-2 minute to his lead over the Ford and at the close of the race had a lead of 8 minutes over Kulick's car. At the end of the fifth lap the Ford had an advantage of more than 10 minutes over Robbins' car, and although the latter from that point onward gained ground consistently on its little rival it was unable to overcome the handicap caused by mechanical troubles in the early rounds of the race, and finished about 7 3-4 minutes behind the Ford.

### Elgin National Trophy

When the cars lined up for the start of the big race it was noticed that the Cino pair, which had suffered severely in the previous day's races, had been scratched. This left ten cars in the field as follows: Alco No. 1, driven by Grant; No. 2 National, Zengel; No. 3 Pope-Hartford, Buck; No. 4 Simplex, Wishart; No. 5 Alco, Lee; No. 6 National, Aitken; No. 7 Alco, Hartman; No. 9 Mercer, Hughes; No. 11 Simplex, DePalma, and No. 12 Lozier, Mulford. The latter, starting out with the evident determination of not alone winning the race but of breaking all records as well, covered the initial circuit in 12 seconds less than his nearest rivals, National No. 2 and Simplex No. 4. DePalma's Simplex negotiated the round 14 seconds slower than did the leader, followed by Grant's Alco, Hartman's Alco, the Mercer, Lee's Alco, the Pope-Hartford and the Aitken National in the order named. The second round saw Mulford add still more to his lead, the end of that circuit showing him to be 26 seconds in advance of Zengel, who had displaced Wishart in the Simplex as runner-up. DePalma still maintained fourth position, with the Grant Alco in fifth place, 2 seconds behind, the remainder of the contestants trailing. The third round witnessed the elimination of two dark horses. Aitken's National going out with a cracked cylinder and DePalma's Simplex retiring to the side lines with a broken fly-wheel. At the conclusion of this round Mulford's advantage had been increased to 33 seconds over the Zengel National,

(Continued on page 366.)

# How to Avoid Jersey on Tour South

## Delightful Trip Promises Much Pleasure

*Embarrassments that confront automobilists in New Jersey under the present law may be avoided only by avoiding the State, and the accompanying article and illustrations show a diversity of routes around that State. The general directions are recommended by the Blue Book and the Touring Club of America.*

**T**O go south from New York City without traversing New Jersey, getting the license required there is a problem very easily solved by taking the road to Tarrytown and crossing the Hudson to Nyack, Suffern and Middletown. In Volume I of the *Blue Book* this is Route 31, the all-New York route to Port Jervis, 96.3 miles. It is fine macadam practically all the way.

Few people will realize without a glance at the map that this variant is only 20 miles farther than the route via Hackensack and Suffern. In addition it is a more interesting country over which better time can be made. Except for those motorists

who must take the most direct route to Philadelphia and vicinity this is a trip to be recommended. For the tourist who has leisure and no enthusiastic desire to "fork over" the requisite for a Jersey license it is the preferable way.

Leaving Manhattan by way of Riverside Drive and Broadway, the latter is followed all the way through Yonkers. En route Spuyten Duyvil Creek is crossed, so titled because a Dutchman swore to cross "en spuyt den Duyvil." There is a modern application of this phrase in taking this particular run "around New Jersey." At Yonkers is the old Manor House, now City Hall, while beyond at Dobb's Ferry a tablet marks Washington's head-

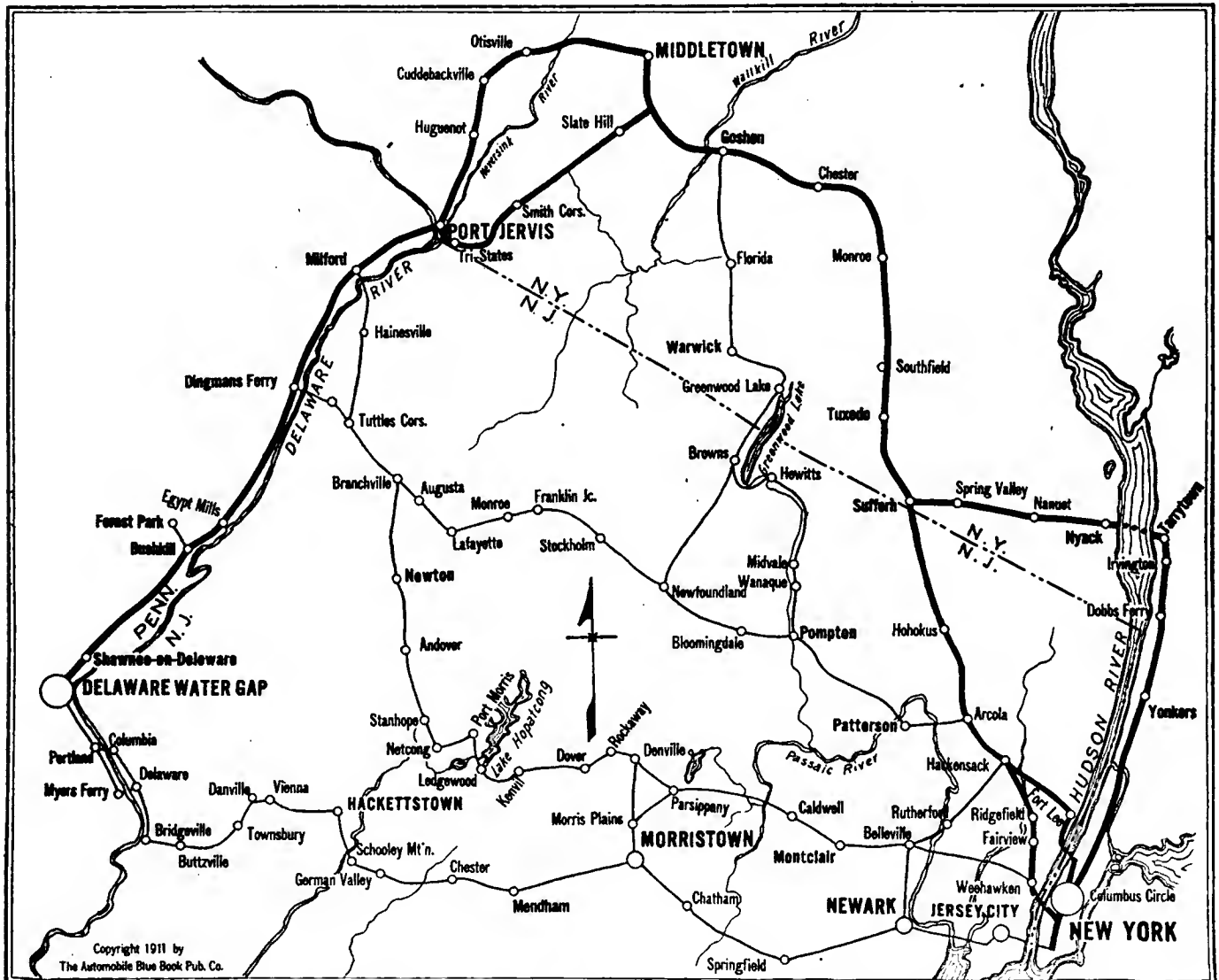

MAP SHOWING HOW THE AUTOMOBILE TOURIST MAY AVOID PUTTING TIRES IN THE SACRED PRECINCT OF JERSEY





1—After leaving the giant steel mills at Bethlehem, Pa.

3—Gettysburg, where Blue and Gray joined battle that shook the foundations of civilization

4—Nyack-on-Hudson, where Aviator Atwood made his last intermediate stop on his flight

2—A New York hillside road traversing a scene of peaceful beauty

5—Tarrytown, N. Y., one of the first and most beautiful of the road scenes to be enjoyed

quarters in 1781. Beginning here the lake-like widening of the Hudson River is called Tappan Zee, along which are situated Irvington, Tarrytown and Piermont, Nyack and Sing Sing. The Zee is ten miles long, and is crossed by ferry at Tarrytown to Nyack, three miles across.

All this region has been made classic by the pen of Washington Irving, one of the few American writers to achieve international reputation. His home, Sunnyside, is at Irvington, and is covered with ivy from a sprig presented by Sir Walter Scott. Paulding Manor and Lynnhurst, the residence of Jay Gould, are near by. In fact, it was said fifteen years ago that in the six miles between Dobb's Ferry and Tarrytown are the country houses of sixty-three millionaires, whose united fortunes exceeded \$500,000,000. At Tarrytown is the estate of William Rockefeller, called Rockwood Hall.

Perhaps the most interesting place on the trip is Tarrytown. There is a monument commemorating the capture of Major Andre, and here is Sleepy Hollow, within whose immortal shadows stands the old Dutch Church (1699). In the churchyard Irving lies buried.

Running west from Nyack the car passes through a comfortable district into Suffern, on the New Jersey line, a small village, but a tourist center because of good roads diverging in five directions. On to Tuxedo, the most magnificent of suburbs, the route follows the Ramapo River. Beyond "Arden," the home of the late E. H. Harriman, turn left into Monroe, Chester and Goshen, thence to Middletown, up a beautiful valley into Port Jervis.

Port Jervis is at the junction of the three States, New York, New Jersey and Pennsylvania. The route to Binghamton, yet in its formative stage, will be the most important connection for travel to Syracuse and Rochester. Port Jervis is also in touch with the favorite section of the Delaware through Milford and Bushkill. All the west side of the river is bordered by natural shale, making a clean, smooth road, free from dust and not slippery. Some dangerous curves are encountered along this stretch of 27 miles, but accidents are few in spite of the constant stream of travel clear into late Fall.

An interesting old Indian fort is to be found across the old Barrett Toll Bridge which crosses the Delaware River into Pennsylvania, and there are a number of beautiful drives from Port Jervis along the Neversink Valley, Hawk's Nest Road and to Saw Kill Falls. High Point (1,600 ft.) is a picturesque resort, as is Lake Marcia, four miles to the east on the ridge of the Kittatinny Mountains.

Seven miles from Port Jervis is Milford, notable for the magnificent Pinchot Mansion with its fine driveway. The experiment station of the Yale School of Forestry is also located here. Numerous waterfalls are worthy of remark on this trip to Dingman's Ferry, with its old ferry and ruined bridge beside a modern iron one. Presently the Delaware makes its famous bend at Fiddler's Elbow, beyond which lies Bushkill, at the junction of the Big and Little Bushkill Creeks. The Falls of the latter are beauties.

Five miles beyond, at the fork near Delaware Valley Inn, the left road leads to Delaware Water Gap and the right turn

leads to Stroudsburg. Various routes lead from these tourist centers to Wilkes-Barre, and Scranton or Easton and Reading southward.

Suppose that one had in view a trip to Washington or Richmond and Old Point Comfort. From the Gap a desirable route runs via Easton and Reading to Gettysburg. Fair dirt roads, numerous grades and bad water-bars characterize the 23 miles to Easton via Portland and Richmond, but the last ten miles are macadam. Easton is a manufacturing town on whose heights are located the buildings of Lafayette College, chartered in 1826. Good roads radiate to New York, Harrisburg, Philadelphia, Scranton. Leaving Easton on fine macadam which continues for 27 miles on the way to Reading, one passes through Moravian settlements, Nazareth and Bethlehem. From Allentown a fine road is followed through Kutztown, near the famous crystal cave, into Reading, a manufacturing city of German origin.

Southwest to Lancaster fair-to-good roads and pike with some stretches of macadam are covered; thence via York to the scene of the great Gettysburg battlefield of the Civil War, now fitly commemorated.

Whether one goes direct to Washington via Frederick on the fair pike, bad when wet, or takes the somewhat better route through Littletown and Westminster to Baltimore, considerable toll must be paid in Maryland. However, one hears occasionally that tolls are abolished, as, for instance, the two tollgates between Frederick and Knoxville, a road which is being macadamized.

The route from Washington to Richmond has been very re-

cently described in THE AUTOMOBILE, and the most recent information regarding it may be obtained from the Touring Club of America. Starting east, then, on Broad street from Richmond, the notable battlefield of Seven Pines is passed on the 56-mile run to Williamsburg, on the peninsula. This was the ancient capital of the State and the seat of the Colonial Government. Points of interest are the Powder Magazine of 1714, old Christ's Church and the College of William and Mary, chartered 1693.

Forty miles out is Old Point Comfort, reached via Hallstead's Point, Warwick, Newport News and Hampton. St. John's Episcopal Church, built in 1658, of red and gray English brick, is one of the sights of Hampton, having a memorial window commemorating the baptism of Pocahontas. For it was her beloved Captain John Smith who sighted Old Point Comfort in 1678, and so named it in spite of the difficulties he subsequently encountered. Fort Monroe is, of course, one of the show places of the coast. Either the fine old fort or the large garrison attracts many visitors. And it is not without a thrill that the tourist looks out upon Hampton Roads, the scene of the engagement between the Monitor and Merrimac.

The Delaware capes and the resorts along the Chesapeake are particularly attractive late in the Summer and early in the Fall and all of them can be reached by the routes indicated herewith. The trip from New York to Old Point Comfort, via Port Jervis, Harrisburg and the south shore should make a delightful four-day tour. Of course it would be shorter via Jersey and will be as soon as the present law is changed.



6—As the road winds away from York, Pa., through tree arches

7—Nazareth, Pa., a picturesque incident along the way

8—One of the routes out of Harrisburg, Pa., showing a bit of river and hill scenery

10—Passing Turner, N. Y., near Tuxedo, the millionaires' resort

9—Skirting the northern hills of the Ramapo mountains

# The Rating of Gasoline Motors

## Method Suggested by C. F. Dendy Marshall, B. A.

*The rating of gasoline motors has occupied the minds of several of the leading technicians connected with the automobile art, but up to the present nothing definite has been evolved that will suit the ideas of everyone concerned. Simplicity of some formulæ brings with it drawbacks, while the complication of others renders them unsuitable. The suggestion contained in this article appeared in the "Automobile Engineer."*

IT is impossible to devise a horsepower formula which will do more than give an approximation. Consequently anything in the nature of complications should be avoided, unless they are justified by unmistakable superiority. The same consideration applies to factors like  $d + a$  constant, where  $d$  is the diameter, and also to roots of the stroke, etc., which cannot be defended on any ground except that they profess to be based on the careful observation of different engines. I use the word profess advisedly, because anything more inconclusive than the first three diagrams in the recently issued report of the Horse Power Committee I cannot well imagine. The dots are literally all over the place, yet they are the record of observations from which the highly empirical formula proposed has been deduced.

There is an exceedingly simple formula which, under average conditions, is capable of holding its own with all the more complicated ones that have been put forward. By "average conditions" I mean within a fairly wide limit of engine speeds, for, if the engine is being overdriven it gives too high a result, but it does not seem to be limited to any particular range of dimensions, as far as engines have at present developed. It has been produced by several independent investigators, of whom I was not the first, though it is frequently associated with my name. I

refer to  $\frac{nsd^2v}{12,000}$  or  $\frac{nsd^2v}{200,000,000}$ , according to whether the

dimensions are expressed in inches or millimeters. Here  $n$  is the number of cylinders,  $s$  the stroke,  $d$  the diameter, and  $v$  the number of revolutions per minute. It is derived from the "PLAN" of steam practice, and assumes the  $\eta p$ , or effective mean pressure corresponding to the brake horsepower, to be 84 pounds per square inch.  $\eta$  is a fraction representing the efficiency of the engine, and effects the change from i.h.p. to b.h.p. It may be objected that this assumption of the mean pressure is a large one to make, but the conditions are very different to the enormous range of pressures in steam engines of different kinds, and this is a fair average, and is, I think, fully justified by the results

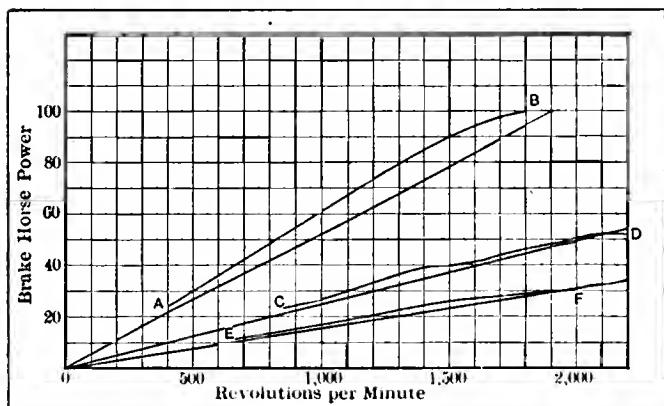

Fig. 1—Characteristic curves of three gasoline engines as compared with the proposed formula

obtained. If the revolutions are unknown, and an idea of the power that would be obtained from a given engine on the road is sought for they may be assumed at 1,000, and the formula becomes  $\frac{nsd}{12}$ , or  $\frac{nsd^2}{200,000}$ . Strictly speaking this assumes that the product of  $\eta p$  and the number of revolutions is 84,034.

This expression is superior to that of the R. A. C.  $\left[ \frac{nd^2}{2.5} \right]$  because, although the latter is considered on the theoretical grounds by its supporters to take into consideration both stroke and m.e.p. the practical result of it is that two engines with the same diameter and different strokes are rated the same, which is absurd, more especially in these days when the tendency is to increase the length of the stroke.

The committee's formula is put forward as "the maximum practicable b.h.p., as determined by a bench test under onerous but safe conditions." I gather it is based on the figures given by Mr. G. A. Burls in the paper accompanying the report. Now, it so happens that in his tables we can see very nearly what is the maximum power that has been obtained from many of the engines. For shortness, I will call the committee's proposed formula—i.e.,  $.45(d + s)(d - 1.18)N - A$ ; Mr. Dugald Clerk's modification of this, in which he multiplies it for the first factor— $B$ ; and the  $nsd^2$  formula I shall in future designate as  $C$ .

Take engine No. 1. It developed by test at a piston speed of 1,275 feet per minute, 37 horsepower; at 1,535 and at 1,705, 41.5. We may take it, therefore, that 41.5 is about the most that can be squeezed out of this engine. The power by formula A is 67.2; by B, 40.3. By C it is 39.6 at 1,275, and 47.7 at 1,535, at which point the engine was already being overdriven. In the case of No. 2 we have 21 horsepower at 937 r.p.m., and 22 both at 1,205 and 1,340. Hence 22 is not very far from the maximum. Formula: A, 63; B, 38; C, 22.4 at 937 and 29.5 at 1,205.

No. 3 is a large six-cylinder racing engine, developing 104 horsepower, at 1,666 feet per minute, which is 2,000 revolutions. It is probable that this is not very much below the maximum. Formula: A, 163.4; B, 98; C, 121.

No. 4 gave 45 horsepower at 1,082, and only 47 at 1,333, so it is clear little would be gained by driving this engine faster.

Formula: A, 103; B, 62; C (at 1,082), 48.4

No. 5 gave 32 at 1,166, and only 33 at 1,417.

Formula: A, 48.5; B, 29; C (at 1,166), 39.8.

No. 6 produced 54 horsepower, at 2,040, which is 2,300 revolutions, practically maximum.

Formula: A, 80; B, 48; C, 57.

In No. 14 we have an excellent indication of the maximum, as it gave 87 at 1,416 and 1,600, dropping to 86 at 1,665.

Formula: A, 155; B, 93; C (at 1,416), 95.

No. 15 gave 32 at 960 32.7 at 983, and 30 at 1,035. Here again the limit is clearly shown.

Formula: A, 90; B, 54; C (at 983), 35.5.

No. 16 gave 37 at 1,160, and 37.5 at 1,320.

Formula: A, 107; B, 64; C (at 1,160), 47.

No. 19 gave 202 at 933 and 204.5 at 955. Possibly this engine might have been pushed considerably higher, but I have worked it out because it is such an unusual size, namely, 12 inches diameter by 8 stroke.

Formula: A, 474; B, 285; C, 275.

No. 20 developed 108 at 1,120 and 109 at 1,200.

Formula: A, 264; B, 158.5; C (at 1,120), D, 143. The last two engines are both considerably below Formula C at all speeds. The cause is possibly bad cylinder proportions. In steam engines it has been found best for the stroke to exceed the bore, and I think the same holds good for these engines.

Nos. 27 and 28 are similar engines, except that one has four cylinders and the other six. It is a very remarkable thing that at five different speeds the powers should be *exactly* proportional to the number of cylinders. This is a case of practice agreeing almost too closely with theory, and one is inclined to suspect the accuracy of the tests, especially the last one, which is at 2,500 revolutions, when one would expect the six-cylinder to have rather the best of it. At this rate they are being driven to death, as No. 28 gave 47.2 at 2,000 revolutions, and only 41.2 at the higher rate of speed.

Formula: A, 87; B, 52.5; C (at 2,000 revolutions), 45.7.

No. 29 gives us a maximum also, as the power was 37.5 both at 1,580 and at 1,900 feet per minute.

Formula: A, 70; B, 42; C (at 1,580), 39.

The series 37 to 40 are extremely interesting, because they are engines with 1, 2, 4 and 6 cylinders all the same size. Here the figures are very close to the proportion of the number of units, without being absolutely correct. As they do not seem to have been driven up to their maximum power, I have not worked them out. In fact, I have done enough to show, from its own figures, that the formula proposed by the committee is of very little use for practical purposes. It is true, I have only taken some of the cases, but as I have simply chosen those which show clearly within small limits what is the maximum power that can be got out of the engines, there is no reason to suppose that those selected are specially unfair to the formula.

I give below four others, which are interesting engines, and show how extraordinarily well the  $n s d^2$  formula adapts itself to widely different types.

I. Sunbeam car; 6 cylinders, 80 × 120 mm.; b.h.p. 46 at 2,000 revolutions.

Formula: A, 92; B, 55.2; C, 46.1.

II. Panhard motor for Lebaudy airship; 4 cylinders, 185 + 200 mm.; b.h.p. at 1,000 revolutions by test 128, by formula C, 136.9.

III. Gnome aeroplane engine; seven revolving air-cooled cylinders 4.3 by 4.7 inches; b.h.p. at 1,000 revolutions, 50 by test, 50.7 by formula C.

IV. Westinghouse motor for petrol-electric railway cars; 6 cylinders, 140 × 160 mm. At 950 revolutions, 90 by test, 89.4 by formula C.

The results of all the above figures seem to be that the Committee's formula for maximum horsepower more often than not works out at about double what can be obtained on test; that Mr. Clerk's modification, which is supposed to be the power usually to be expected on the road, gives somewhere about the real maximum, and that the one I have always advocated is slightly too much at high rates of revolution. The reason for this is not far to seek. When an engine is being tested at various

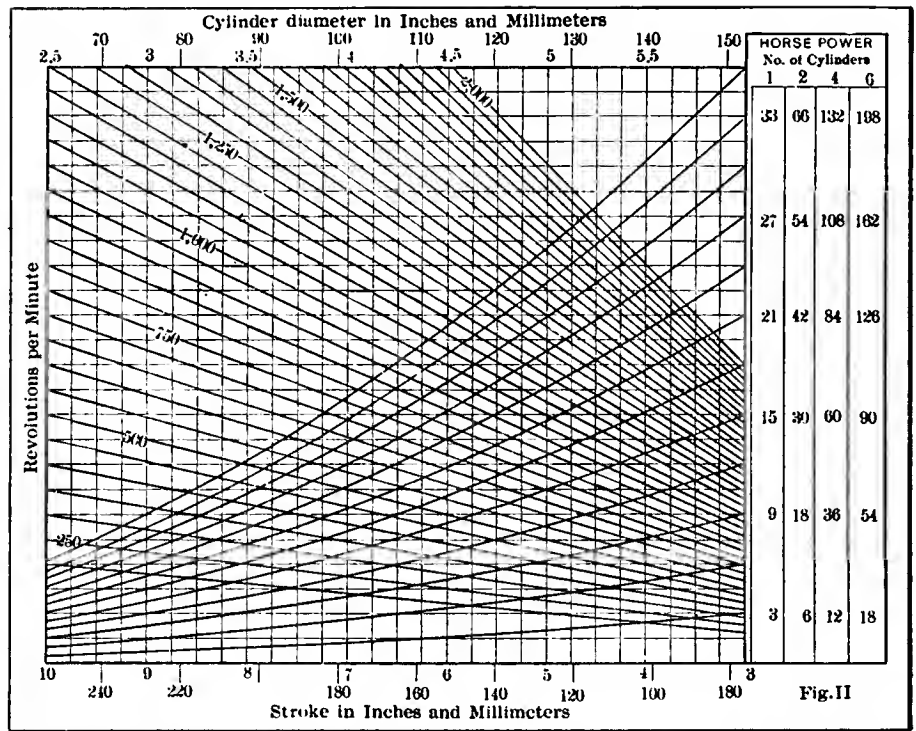

Fig. 2—Comprehensive chart showing the horsepower for various motors which can be read off at a glance, taking bore, stroke and engine revolution into consideration

speeds, after it has got into its stride, the horsepower rises steadily with the revolutions, until a critical speed is reached, after which it goes up more slowly, finally coming down again. Fig. 1 gives the characteristic curves of three petrol engines. The line AB is that of a six-cylinder Napier, cylinders 4 1-16 by 7 inches. By the committee's formula it should be capable of developing over 156 horsepower. CD is from a four-cylinder Sunbeam, 95 by 135 mm., and EF from a Crossley engine. The straight lines adjacent to the curves represent the  $n s d^2$  formula for each engine. If it is desired to estimate the maximum power by this formula, and the revolutions are unknown, it can be done more or less accurately by assuming a number for them, based on experience, and the dimensions and design of the engine. Fig. 2 is a chart giving the horsepower by the  $n s d^2$  formula.

This is used as follows: Enter at the bottom of the measurement for stroke, and run up until the correct revolution line is intercepted, then pass horizontally to the right and take the curved line which starts at the point of arrival. First, I will assume there is one just right. Go down it to the left until you are under the diameter on the top scale. The height of this point from the bottom gives the horsepower at the right side. If there is not a curve available, and it is necessary to interpolate, it is quite easy; you estimate the ratio in which the point arrived at divides the space between the two adjacent curves, then the required point below the diameter will occupy a similar position.

To take a practical example, the horsepower of the Sunbeam, my No. 1, is found as follows: Enter at 120 stroke and pass up until you intercept the 2,000 revolution line, then go across to the right. This lands you just about midway between two curves. Follow the curves back until immediately beneath the diameter, 80 mm., and take a point just below halfway between them, then run across to the right, where you arrive at 46 horsepower. It is worth pointing out that the exact equivalent for the constant 12 when millimeters are used is 196,634. The effect of taking the round number of 200,000 gives a result just under 1 3-4 per cent. lower, which is quite near enough for all practical purposes, a variation which, of course, is quite negligible, considering that an approximation is all that one can aim at in devising a formula.

# Accidents Come in Groups

## A Chain of Disasters Often Caused by a Single Mishap

*When the connecting rod cap bolts fail the damage is liable to involve many more parts than those originally affected. A small amount of play in this part of the motor will give rise to rapid wear, which will result at first in a knock and afterwards in disaster. Neglect may be dangerous and the knock should be eliminated as soon as it appears.*

IT is an old saying that misfortunes never come singly, and in many ways the saying has borne itself out in facts, but in such cases it may have been remarked that the misfortunes were to a large extent dependent upon each other and followed along in a natural sequence which could not be interrupted. A chain of accidents may hinge upon some peculiar condition caused by a derangement of one of the component parts of a machine which has been the result of a very trivial cause.

A glance at the broken crankcase in Fig. 1 will show to what extent the damage may be transformed from one which would be easy to repair to one which requires the replacement of several parts. The connecting rod cap is shown to be broken off and this is what caused the rest of the damage. After being freed from the crank bearing, the connecting rod knocked the piece from the side of the crankcase walls. Another case is shown in Fig. 2, where the connecting rod has been driven through the walls of the cylinder owing to a broken bearing cap.

The last-named accident happened to a car with a horizontal engine and is, of course, only to be repaired by buying a new part. In the former, where the connecting rod has pierced the walls of the crankcase the repair may be made by bolting a cover over the fracture and fitting a gasket so that the patch will be oil-tight. There is always a mist of oil present in the crankcase even if the lubrication system should not happen to be the splash method of lubricating, hence a gasket or some other form

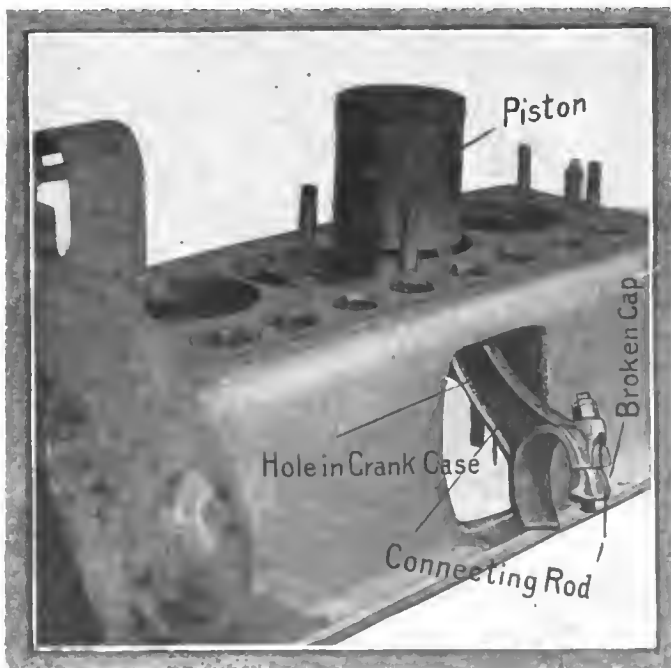

Fig. 1—A case where a broken cap bolt was responsible for further damage. The connecting rod has pierced the crankcase wall

of packed joint should be used in placing the cover over the hole.

In ordering a new part for a repair, such as the accident to

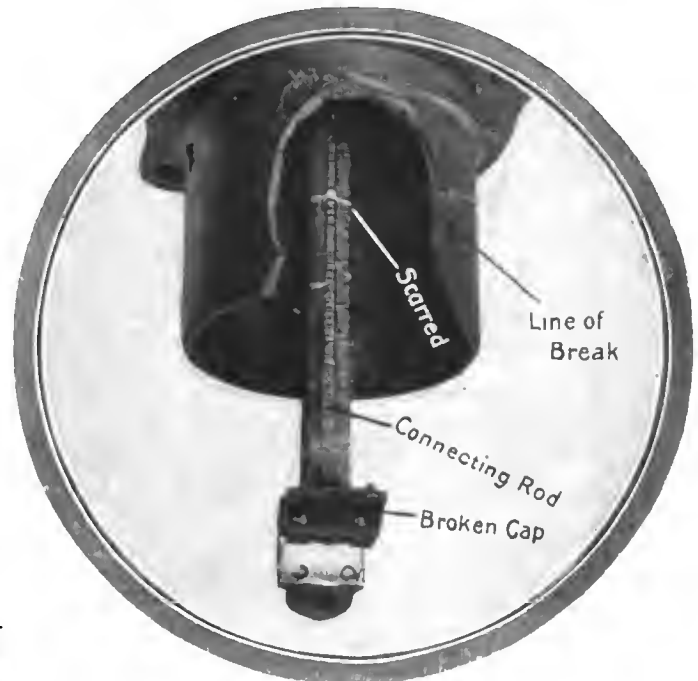

Fig. 2—Illustrating a broken cylinder which was caused by the failure of one of the connecting rod bolts. The following revolution of the crankshaft drove the connecting rod through the cylinder

the horizontal cylinder would necessitate, the piston should accompany the cylinder so that a proper fit is obtained. It will often be found, however, that the piston is sent, placed within the cylinder as shown in Fig. 3 (which is the new part to replace the broken one), and that some sort of lubricating matter has not been placed on the piston before it has been inserted. As a result, when the piston reaches the repairman he is unable to withdraw it. The illustration depicts a futile attempt which was made to withdraw the piston by placing a rope around the wrist pin and pulling thereon. The cylinder had to be soaked in kerosene for twenty-four hours and the piston hammered loose before it could be removed. It had rusted in the cylinder.

Broken connecting rod caps, while not a common occurrence, generally cause much more damage than just that to themselves. As the connecting rod is released it will swing loosely as a pendulum from the wrist pin, the revolving crankshaft will come around and hit it a series of blows which will have sufficient force, as a rule, to send it through any metal which may be in the way, if the motor is not stopped in time to prevent several blows. Very often one revolution is enough to do the damage.

The connecting rods themselves are naturally very much



battered up after an experience of this sort, so that the list of articles requiring replacing will naturally include one of these. An inspection of the two illustrations which show the broken parts will give an idea of the grinding and twisting to which the connecting rods were submitted; they have resisted the force of the blows better than the brittle castings, which was to be expected, owing to the inherent difference of the qualities of the material. In fitting a new connecting rod great care must be observed that it is of the same length as the others for a slight difference in length will make an appreciable difference in the clearance volume, which will materially influence the amount of compression. Trouble of this nature will not, as a rule, annoy the purchaser of spare parts, as the product of the factory will be found to be so standardized that interchangeability will be a matter of course; still where several years have elapsed between the time of replacement and the model of the machine a comparison should be made before fitting.

The connecting rod bearing cap is generally fastened by means of two bolts which are placed in bosses one on either side of the crankpin bearing so that the piston may be conveniently



Fig. 3—Method used in an attempt to remove piston from cylinder. This means proved inadequate, as the piston had rusted within the cylinder

withdrawn as shown in Fig. 4. These two bolts are subjected during the power strokes of the motor to practically no stress at all since the rod is under compression and all strains are taken up by the crank bearing. There are certain parts of the stroke, however, where the connecting rod is in tension owing to its inertia, for instance, when after reaching the bottom of the power stroke the tendency of the connecting rod is to continue traveling in the same direction, it is checked by the upper part of the crank bearing which swings about and pushes the connecting rod and piston up into the cylinder. During all this time the rod is under compression and there is no strain on the bearing cap bolts, but when it has reached the top dead center an explosion takes place in another cylinder and pushes the crankshaft around. This will pull the connecting rod down and with it the piston which will put the rod in tension and place the strain on the cap. All the strain on the connecting rod caps is taken up by the two bolts when the rod is in tension.

The changes from compression to tension in the rod and hence in the rod attachments will be very sudden and it is evident that a very small amount of play in the bearing cap connection will cause rapid wear on account of the high inertia of the heavy moving parts, which, instead of being gradually reduced to

zero as they would be in a case where there is no play, are brought to rest with a jerk which takes the effect of a hammer blow. It is impossible to bring a moving body instantaneously to rest. The lapse of time may be almost infinitesimal in the case of a light body moving at low speed, but the kinetic energy must have had time to dissipate itself either by being brought to rest slowly by the action of a contrary force or by impact with another body in which case there will be an elastic vibration set up which will consume some of the energy while the rest will be converted into heat. This latter is what takes place in a bearing in which there is excessive play and where the inertia forces are large, as they are in the case of the connecting rod bearing. The continuous impinging of one part against the other will cause a wear which will cause more lost motion as time goes on and will eventually develop a distinct knock in the motor. This is the danger signal and the wise motorist will heed it and search until he has found it.

Since the two bolts in the bearing cap take all the tension to which the connecting rod is submitted and are not subjected to any other appreciable stress it is evident that they should be large enough so that each be one-half as strong as the rod, plus a small additional factor of safety for wear.

Failure of the connecting rod is not very common for a variety of reasons, the greatest among them being that common practice has evolved a connecting rod which is somewhat heavier than actually required, and makers are not very anxious to tempt fate by cutting down weight in this part of the mechanism. All the force of the explosion is carried from the piston head to the wristpin and by means of the connecting rod to the crankshaft. When the ignition is early the strains endured are greatly augmented, especially if it is so early that a pounding results and places a severe compressive stress on the rod. If failure should occur, however, as is always possible, it would be in the nature of bending instead of crushing as is ordinarily assumed, since the connecting rod is a column.

It is very likely, as stated at the head of this article, that should the connecting rod fail, damage on a much more extensive scale than merely that to the original parts affected would be almost sure to result, but it nearly always starts in a small amount of play in some vital part and the careful man may save great expense by attending to the first small knock. The illustrations in Figs. 2 and 3 shown herewith are from photographs taken at R. M. Owen's repair shop, 1759 Broadway, New York City.

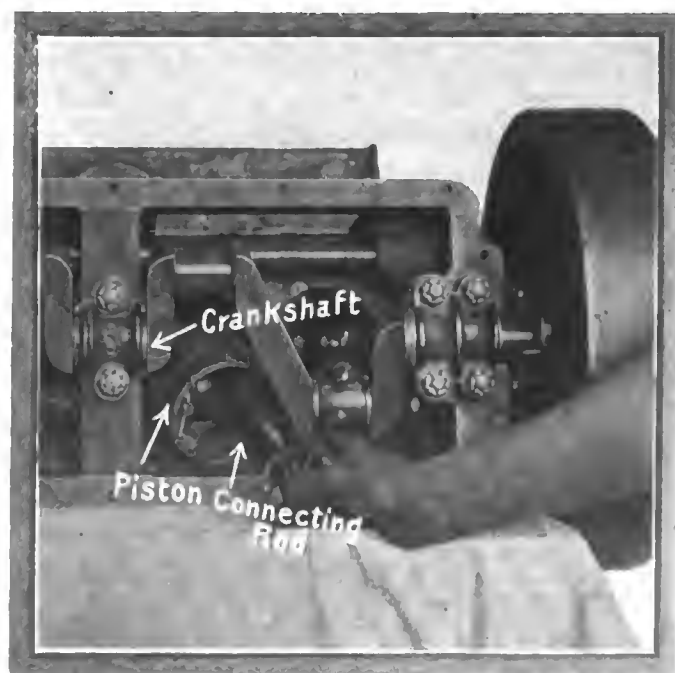

Fig. 4—The piston, connecting rod and attached parts may sometimes be withdrawn by removing the connecting rod bolts

# Convertible Body for Depot Work

## A Design Adapted for Suburban Use

*Besides the carrying of passengers there will be of necessity a great many pieces of baggage to be carried to and from the depot. The body shown and described herewith, designed by George J. Mercer, is intended to meet all the exigencies of suburban service, both as regards passengers and their luggage.*

THE requirements of a car which is designed to carry passengers to the railway depot in the morning from their places of residence and in the other direction in the evening, not to mention the various trips in either direction during the day with a stray passenger or two, are various. Such a vehicle must have room for trunks, as there is generally no express depot in the rural districts and all the hauling is done by the local liveryman. To maintain a horse service besides the automobile would greatly impair the efficiency of the scheme, as it would double the cost, while an all-horse outfit would be cheaper than the combination.

The problem could readily be solved, it is true, by maintaining two or three automobiles with different types of bodies, and that is what is generally done under the circumstances. This, of course, entails a large first cost and also an increased cost of upkeep and has been without doubt the cause of a great many suburban liverymen not having adopted the automobile service with its many advantages of speed and flexibility. To meet these requirements the convertible body has been suggested.

The body may be arranged in three different ways which are depicted in the accompanying illustrations. Fig. 1 shows the car arranged with two seats and a top which may be folded down at the convenience of the driver; when folded down as it is shown in the cut, the top takes up the position which is indicated by the dotted lines. When arranged in this manner the car is adapted to four passengers and the space at the rear will carry a small amount of luggage which will in quantity be more than the amount usually carried by four average passengers.

The next illustration, Fig. 2, shows the body arranged as a wagonette with side seats in the rear part of the wagon which are each capable of holding three persons, making a total of

six passengers in the rear and two on the driver's seat, or eight altogether. A top which is provided with side curtains is fitted on this model so that in case of a storm they may be lowered and the passengers protected. A celluloid curtain protects the driver, so that in the way of protection in all kinds of weather, a point most necessary in this work, this car is amply protected.

The entrance to the rear part of the car is effected by means of a step which is lowered only when it is required. At other times it is kept folded against the rear of a tool box which is carried suspended beneath the car. The step is shown in dotted lines in its two positions in relation to the tail gate, which is also lowered when required and provides the landing step.

When used solely for trunk-carrying purposes the body is arranged on a purely wagon basis even so far as having side wings, as shown in Fig. 3, in case the packages are of great bulk or if there are a great many of them. The loading space back of the seat and inside the tailboard is 3 feet 10 inches long, and the wheelbase on the chassis is 114 inches in length. The chassis is of runabout type with the steering column sloped at 45 degrees and shortened so as to place the driving seat 24 inches from the dash.

There are a great many people who are located in various parts of the country at a distance of between twenty-five and seventy-five or even more miles from large cities who make their living during the Summer by carrying passengers to and from the railway station, besides having a contract with an express company to deliver all goods which are directed to houses within the district covered by the wagons. Outside of the actual passenger traffic there is the consequent baggage, which amounts to a large item since there are a number of transient visitors to these suburban places who stay perhaps over a short vacation period or merely for the week end. In a great many cases along the seashore the coast line is so irregular that the railroads do not attempt to follow along its deviations but content themselves with running their line about a mile inland so that they can operate with as few bends as possible. The people who live in the country districts will be found to greatly favor the vicinity of water. This is especially the case where the inhabitants are largely made up of those who live in town during the Winter and along the water front in the Summer. Owing to the irregular shore line there are many spots where the railroad is at a very great distance from the homes of the passengers.

The service given by the horse met the exigencies of a two-mile trip as well as could be possible, making the trip in fair time and being very reliable except in extraordinary cases. Above this distance, however, a trip to the depot became more or less of an ordeal for the commuter so

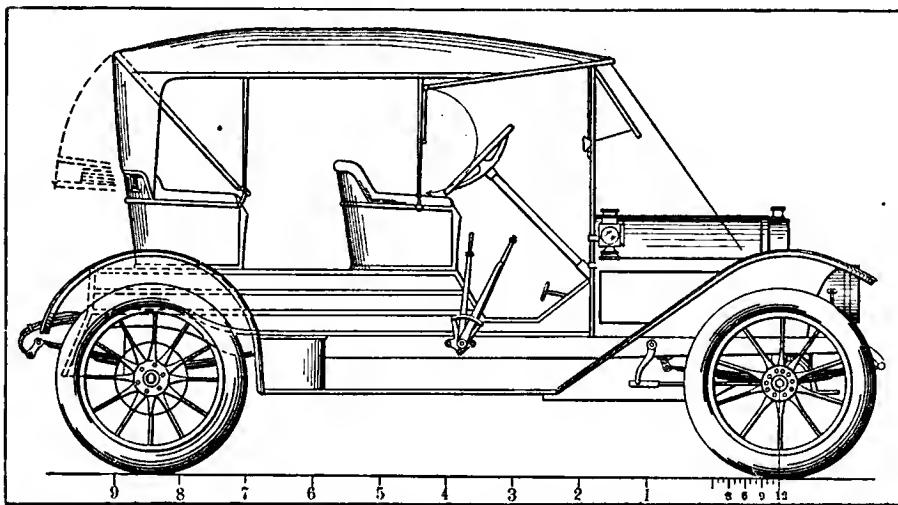

Fig. 1.—Showing the convertible body as a two-seated passenger car

that he was prone to pick out a less favored spot in order to bring himself within such a distance of the depot that he may spend a fair part of the evening in sleep instead of making a hurried rush in the early dawn for a train that will take him to town in time for the opening of the business day. The coming of the automobile has gone far to revolutionize these conditions and a trip of even five miles has no terrors for those who are in reach of its services. In a great many cases the Summer visitors have their own cars, but on the average there is a very large number who are not so provided and who would appreciate an up-to-date liveryman who would provide the rapid service which is possible with an automobile. To maintain a service which would take care of both passengers and baggage it is necessary as a rule that vehicles of large capacity be used. This will depend, however, on the demands due to the size of the population.

From this description and the illustrations which accompany it it is evident that it is possible to have a convertible body for this type of work which, besides possessing ability, will present a neat appearance.

### Gas Generator Needs Care

*The parts of the gas generator which are located in such a position that they are apt to be subject to lime deposits need constant care so that their action is not prevented by the subsequent clogging. Occasional attention will go far toward prolonging the life of the generator.*

THE parts of the carbide carrier which come in contact with the water distribution apparatus are liable to clogging by the formation of lime residue in the generation of gas. If this residue is allowed to collect, it will have to be removed with a chisel, which is a delicate operation in a light construction like that of a generator, especially around the water valve or its outlet. Acids are sometimes used to remove the deposit, but as they eat the metal, their use should be prohibited. The basket and pot should be thoroughly washed out after each run with water, the water outlets being cleaned with special brushes, when these are obtainable, or by wires, removing all traces of lime.

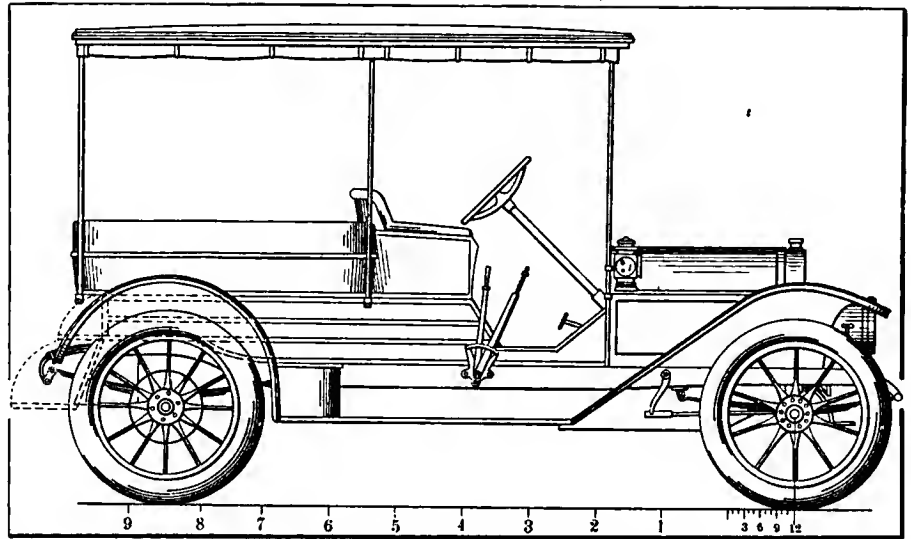

Fig. 2—The convertible body is shown as a wagonette, with space for six passengers in the rear and two in the driver's seat

The water valve should be scraped and tested to see whether it seats properly, care being taken not to damage the valve or its seat in so doing. While the valve is dismantled for cleaning it would be well to see that its stem is straight and that it works with some ease in the threaded portion attached to the water chamber. The gas valves should be cleaned and should seat snugly, so that there will be no leakage past them. This applies also to the gas valves on the lamps. It must be remembered that the best polish on the outside of the brass work has nothing to do with the condition of the interior.

The best position for the generator is on the running board just back of the change gear quadrant, and sufficiently far out from the frame to allow a free circulation of air all around it. The generator will keep cool in this position and will perform its work to the best advantage when properly cooled.

ENGLISH TAXI CHAUFFEURS NOT WORKMEN—A bill recently introduced into the House of Commons has to do with a recent decision of the House of Lords, to the end that taxicab drivers are not entitled to the benefits of the Workmen's Compensation Act, 1906, on the ground that they are not "workmen" in the legal sense of the word. The bill is intended to reverse the decision.

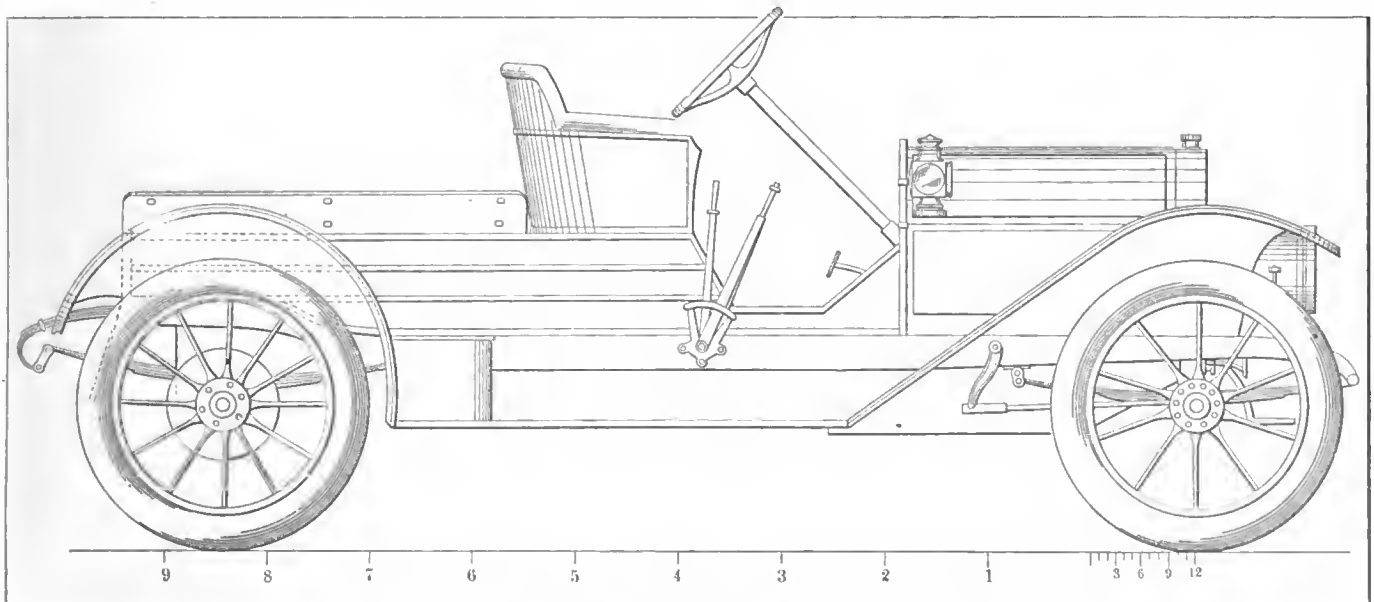

Fig. 3—Illustrating the convertible body as a trunk-carrying vehicle

# Letters Answered and Discussed

## Wants to Darken Brass

EDITOR THE AUTOMOBILE:

[2,797]—Some weeks ago I saw a statement that olive oil added to some other ingredients and applied to brass would darken same and hence relieve one of the necessity of polishing it. I have lost the copy of the receipt and am asking you therefore to repeat the receipt. J. M. D.

Bowling Green, Ky.

A receipt published recently in these columns was as follows: Dissolve 100 parts of copper nitrate in from 100 to 200 parts of water; it is possible to form a solution in which the parts may be immersed or if too large the solution may be painted thereon. Then drain or shake off the surplus solution and heat the article so as to decompose the copper salt into a black copper oxide. The heating can be carried on over a clear charcoal fire or in a closed muffle furnace.

## Small Cylinder Design

EDITOR THE AUTOMOBILE:

[2,798]—Could you tell me through your letter department how to figure the amount of iron in the cylinder of a four-cycle, single-cylinder, air-cooled motor of motor-cycle type? What is the thickness of the cylinder at the combustion chamber and at the side walls? Give formula for calculating the size of the connecting rod and piston of a motor 3.3-4 x 4 inches and tell me what are generally the length and thickness of the flanges? How is the cylinder fastened to the crankcase and what is the formula for determining the size and

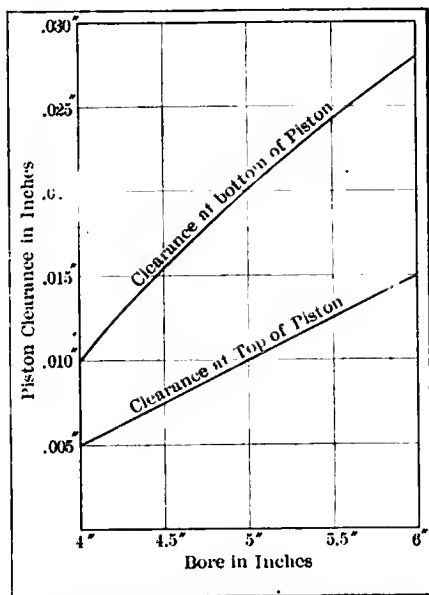

Fig. 1—Curves of piston clearance, showing the correct amount at top and bottom

## Announcement

### MY 1912 AUTOMOBILE

So much interest is being taken in the coming 1912 models that criticisms are already being heard to the effect that the 1912 automobile is not meeting the expectations of many readers of THE AUTOMOBILE. In order to discover exactly what are the conceptions of the many readers on the 1912 machines THE AUTOMOBILE started last week a discussion on the 1912 models and hereby invites every reader to mail in what are his or her conceptions of next year's car. The information given should include such points as:

- |             |                     |
|-------------|---------------------|
| Horsepower  | Tire sizes          |
| Bore        | Rear axle           |
| Stroke      | Front axle          |
| Ignition    | Control parts       |
| Lubrication | Body features       |
| Carburetion | Equipment           |
| Clutch      | Cylinder type       |
| Gearset     | No. of cylinders    |
| Drive       | Cylinders, how cast |
| Springs     | Price               |
| Wheelbase   |                     |

In addition to giving these details the reasons for your points of selection should be stated concisely and clearly.

As a benefit in the matter of comparison some details of the average cars for 1911 are given herewith, these details being for cars selling at \$1,000 or thereabouts; \$1,500 or thereabouts; \$2,500 or thereabouts, and \$4,000, thereabouts and up.

Each communication must be legibly written on one side of the paper only; it must be properly signed, with the writer's full name and address, and if the writer does not wish his own name to appear in print he may request the use of any nom de plume.

Any reader desiring to make line drawings, showing details of his ideas of his car or some of its parts, is requested to do so.

Editor THE AUTOMOBILE.

weight of the piston for this size of motor?

H. E. RIEGEL.

St. Paul, Minn.

A cylinder of the size mentioned in your letter would be about three-eighths of an inch in thickness. The cylinder head in a cylinder of this size would be cast with the walls in one piece and would be of the same thickness.

If a plain rectangular connecting rod is used the average thickness of the rod would be:  $t_r = .008d\sqrt{P_m}$ , where  $P_m$  is the

maximum pressure on the rod and  $D$  is the cylinder diameter. The cylinder is fastened to the crankcase by flanges and bolted, the joints either being provided with a paper gasket or ground. For an engine of this size the width of the holding flanges would be 2 1/2 inches and three-eighths of an inch thick. The piston length is 1.2  $d$ , where  $d$  is the cylinder diameter. The maximum pressure on the piston head would not exceed 240 pounds to the square inch. The formula for the thickness of

$$\text{the piston head would be: } T = r\sqrt{\frac{5}{6} \cdot \frac{P_m}{F}}$$

for flat heads, where  $r$  is the active radius in inches,  $T$  the thickness in inches,  $P_m$  the maximum pressure in pounds to the square inch and  $F$  is the working stress in the metal and can be taken as 4,200 pounds per square inch.

The weight may be found by estimating the material in the piston and multiplying it by the weight of cast iron which is .260 pounds per cubic inch.

## Proper Piston Clearance

EDITOR THE AUTOMOBILE:

[2,799]—I am desirous of having a new cylinder made for my car which is not being made any longer the manufacturers having given up the business, I would like

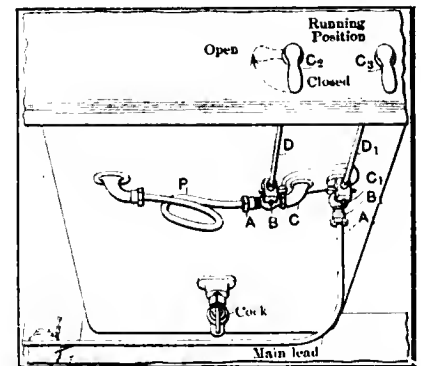

Fig. 2—Illustrating the fittings placed under a gas-oline tank

to know the correct clearance to allow between the piston and the cylinder. Should the clearance be the same at the top and bottom? A. F. D.

Pekin, Ill.

The clearance should be different at the top and bottom of the piston. As you neglected to mention the bore and stroke of the engine it is impossible to give you figures. A diagram is given herewith, Fig. 1, which will, it is hoped, prove satisfactory in your case as well as in any other of the kind, as it shows the correct clearance for an engine of any bore up to 6 inches.

Wants Varied Information

Editor THE AUTOMOBILE:

[2,800]—Being a subscriber to your valued paper, I would like to ask the following questions:

(1) In a motor of 70 pounds compression, assuming that combustion is perfect, what is the temperature of the mixture at the instant of explosion?

(2) What is meant when a motor is said to have a compression of 50 pounds absolute?

(3) What would be the temperature of a perfect mixture of gasoline and air burned under a pressure of 110 pounds per square inch?

(4) Assuming conditions of question 3, what would be the temperature of kerosene and air?

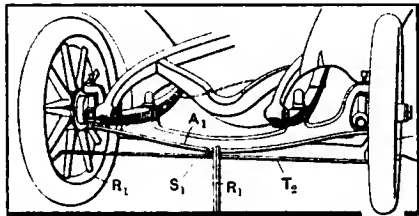

Fig. 3—Illustrating method of determining parallelism of the wheels

(5) What is the chemical composition of kerosene?

(6) In your article on cooling and efficiency in issue of August 3 you mention a two-cycle engine. Could you explain the operation of this motor? G. W. R.

South Auburn, Neb.

(1) Since the specific heat of gases varies as the temperature increases it is not possible to accurately determine the temperature of combustion in the cylinder on this basis even though the calorific value of the fuel be known.

(2) Absolute pressure is pressure above zero, while gauge pressure is that above atmosphere.

(3) and (4) are answered under (1).

(5) Kerosene is a mixture of hydrocarbons chiefly of the methane series. Methane gases are of the form of  $C_nH_{2n+2}$  as  $C_4H_{10}$ .

(6) We have no full description on hand at present of the motor to which you refer.

Wheels Not Parallel

Editor THE AUTOMOBILE:

[2,801]—Would you kindly tell me a method of testing the wheels of a car to determine whether they are parallel? The front tires on my car wear at such a rapid rate that I am inclined to believe there is something wrong in their alignment.

M. G. H.

Albany, N. Y.

The accompanying sketch, Fig. 3, will give a method of testing the wheels. A tubular pointer  $T_2$  with an indicator on either end is used. This pointer consists of two parts, one smaller than the other, so that it may be slid inside and held in any position by the lock nut in the center  $S_1$ . A rule  $R$  is set up, and the height measured along the tube so that it is parallel. The tube is held in position and is adjusted so that it is parallel to the ground. The method of determining the parallelism is to find the distance between the outer edges of the rim at the front at a given height say 10 inches from the ground and after locking the gauge the same should be placed at the rim at the rear of the wheel at the same height as at the front. There should be a slight toeing in towards the front dependant upon the size of the wheel.

Lifting a Motor

Editor THE AUTOMOBILE:

[2,802]—I have a small garage where I do a great deal of repair work on all types of engines. Would you kindly describe a rig for lifting all types of motors?

L. K. L.

Trenton, N. J.

A block and fall could be set on the overhead beams from which an arrangement consisting of a center bar with four drop arms as shown in Fig. 4 which can be used on any type of motor to either lift it out of the chassis or hold it suspended while work is being done.

Condemns Improper Material

Editor THE AUTOMOBILE:

[2,803]—The following analyses of a gear wheel which was put into a car now

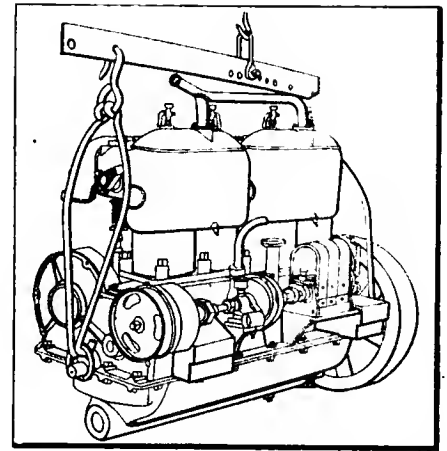

Fig. 4—Showing a device for lifting the motor from the frame and carrying it to another part of the shop

listed for \$1,700 may be of interest to your readers as an example of what *not* to buy for this purpose:

Sulphur, 0.056 per cent.

Phosphorus, 0.115 per cent.

Manganese, 0.56 per cent.

Carbon, 0.12 per cent.

Oxides and slag, 0.65 per cent.

This is evidently a poor grade of soft Bessemer steel and was case-hardened. The steel was so laminated as to look at first glance like a poor grade of wrought iron. The gear teeth broke, causing considerable damage. The ignorance or carelessness of anyone using steel like this is hard to understand.

F. N. SPELLER.

Pittsburgh, Pa.

Gasoline Tank Piping

Editor THE AUTOMOBILE:

[2,804]—Would you kindly tell me what pipe fittings it is necessary to buy in installing a gasoline tank for an automobile. I intend to do the work myself and would appreciate any help.

J. E. S.

The accompanying Fig. 2 will show a tank tilted which can be made with two compartments, be placed in communication by the pipe  $P_1$  and the lever  $C_2$  which operates the cock  $B$ . The lever  $C_3$  placed alongside the lever  $C_2$  controls the main flow and should be down when open.

DETAILS OF AVERAGE 1911 CARS WHICH WILL ENABLE READERS TO MAKE COMPARISONS IN DISCUSSING 1912 MODELS

	\$1,000 and thereabouts	\$1,500 and thereabouts	\$2,500 and thereabouts	\$4,000 and thereabouts
Horsepower	20.5	29.525	35	43.66
Bore	3.98 inches	4.19 inches	4.40 inches	4.875 inches
Stroke	4.12 inches	4.64 inches	4.98 inches	5.39 inches
Wheelbase	100 inches	114 inches	119 inches	124 inches
Front tires	31.4 x 3.3	33.1 x 3.8	35 x 4	35.7 x 4.27
Rear tires	31.4 x 3.3	33.1 x 3.8	35 x 4.1	36.7 x 4.55
Number of cylinders	Four	Four	Four	Four
Cylinder type	L-Head	L-Head	L-Head	T-Head
Cylinders cast	Pairs	Pairs	Pairs	Pairs
Ignition	Dual	Dual	Dual	Dual
Clutch	Disc	Multiple disc	Cone	Multiple disc



# Little Bits of Motor Wisdom

## Pertinent Pointers for Repairman and Driver

*A series of short stories that will tend to keep the automobilist in touch with matters mechanical and otherwise, covering a field of information that although usually well tilled, needs frequent and careful cultivation to produce the greatest results.*

**ATTENTION SHOULD BE PAID TO BRAKE SHOES**—Very often the cause of a mysterious rattle will be located in the brake shoes which have worked loose owing to an irregular wear, which has set up unbalanced strains in the drum and given rise to the chatter which is peculiar to this trouble. There are generally two complete sets of brakes carried in the later models of nearly all cars. An illustration of the way these two sets are set up on a single drum is given in Fig. 1, in which a set of expanding and contracting brakes is shown. The contracting or band brake is operated by the bell-crank lever which tightens the band so that a braking effect is attained around a large part of the periphery of the drum. In the internal expanding brake, in a hollow drum which is continually revolving with the wheel or some other revolving part of the car's mechanism there are two metallic shoes which are capable of being pressed firmly against the inner surface of the drum by means of a cam or toggle joint. The advantages of the latter type of brake

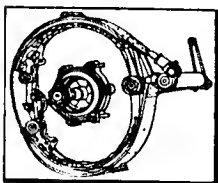

Fig. 1—Form of internal and external brakes used on modern cars

are that it is less liable to remain set against the drum after the operator's pedal or lever has been released. It is also very easily adapted to either a forward or reverse motion of the wheels and will give a greater braking effect for a given pressure on the braking mechanism. One of the greatest of all its advantages however, is the fact that it can readily be made mud or grit-tight and prevents the parts from rusting.

Besides metal to metal contacts the shoes are sometimes covered with an asbestos woven fabric riveted to the surfaces and known as a liner. These liners are readily removable and are less likely to burn out than the metal to metal type. The shoes are sometimes fitted with cork inserts which increase the coefficient of friction and thereby the braking powers.

To provide a surface which will stand both the heat and the wear has been the

ambition of those interested in the manufacture of brakes and they have developed a form of reinforced asbestos.

**FILLED THROUGH SUPPORTING ARM**—A practice which has been affected by various

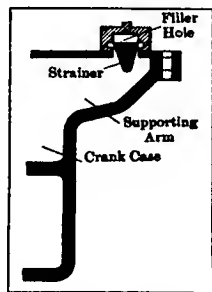

Fig. 2—Position of filler hole when placed in the crankcase supporting arm

people is to have the crankcase oil filler hole placed in the supporting arm. In this way a large opening may be had, a feature which the breather pipes very often lack. In case the filler opening on the car is smaller than desired by the owner and he finds it impossible to fill the crankcase without great waste and consequent uncleanliness it is often possible to have an opening placed as shown in Fig. 2.

**THE PRIMING CUP HAS ITS USES**—A fitting which is placed on the top of the cylinder and which has a variety of uses is the priming cup. They are made in divers styles and sizes with a standard pipe thread by which they are connected to the cylinder. The type illustrated in Fig. 3, with a small cup on the top of the compression cock, is very satisfactory, especially since it is protected well against leakage by means of a spring which holds the valve plug in place. When starting the car after it has been cold for a length of time it may sometimes be found necessary to prime the motor. The small cup on the top of the cock forms a measure

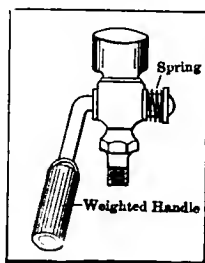

Fig. 3—Compression cock and priming cup combined in which a spring and weighted handle tend to keep the valve tight under all conditions

which can be filled while the cock is closed. The valve is opened by lifting the handle

so that it stands upright. The cock will not jar loose while the car is running as the handle is weighted, so that the tendency will be that the handle becomes tighter as the jar continues.

**SPLASH SYSTEM MUST BE WELL DESIGNED**—In arranging a splash system it must not be assumed that the car is always going to run on level ground. The oil, like all other fluids, has a great aptitude of flowing down hill so that when the oil pan is tilted, unless there is some arrangement to hold the oil in position, it will all collect at one end of the crankcase and while the cylinders at that end will be fairly drowned in oil the others will suffer a great want of the same important liquid. Fig 4 shows a longitudinal section through a crankcase in which the splash system of oiling is used. It is easily seen that if some means of prevention is not incorporated in the system the oil will run to one end of the

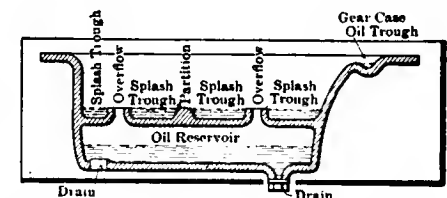

Fig. 4—Longitudinal section through a crankcase in which the splash system is used

crankcase and collect there until the small drainage pipes can drain it off into the reservoir below. In Fig. 5, the narrow splash trough which is often used as a means of overcoming the tendency is shown, the object being, as the diagrams show, to keep the oil in such a position that the connecting rod cap will reach it at whatever level the car happens to be running at the time.

Another means adopted in a large number of cars which are lubricated by the splash system is to incorporate a number of slanting troughs along the walls of the splash chambers. These troughs are so arranged that the oil is continually being thrown into them by the connecting rods. They lead the oil back to the next trough where it is picked

up and thrown into the trough which carries the oil back into the next chamber and so on until it has reached the last of the series, whereupon the oil is caught in a duct which leads it back to the first trough. The leads on the walls are sloped so severely that it would be impossible for the oil to be led back in the opposite direction on account of descending any hill no matter how steep the same may be. Besides the set of troughs in the walls there are also a series of overflows which take the oil back to the reservoir which is located in the lower part of the crankcase below the tray which carries the splash troughs. These overflows are necessary since the supply of oil is continually being augmented by that which is forced into the oil pan by the pump.

Another method of keeping the oil from collecting in any particular section of the crankcase where the splash system is used is the simple one of providing very large overflow holes and a rapid circulation. If the overflow holes were large without the

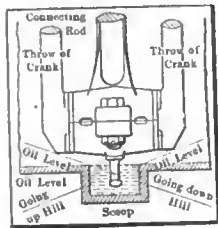

Fig. 5—Small splash trough. This cut shows the influence of road level on the oil in the trough

rapid circulation the oil would overflow down into the reservoir and would not be replaced rapidly enough to fill all the splash troughs. With a rapid circulation the oil is either generally led into the foremost compartment and then allowed to find its way back over the

walls into each successive trough, or it is led into each separate trough by tapping for leads into the main oil carrier pipe which will run the entire length of the crankcase.

The greatest care will be necessary in not having a flooded condition of one part of the crankcase when the system is not circulating but the oil is carried in a separate tank which is just drawn upon sufficiently to replace the oil which has been used. In this case the system is generally a combination of both the force feed and splash systems, the oil being led to the main bearings and allowed to lubricate these copiously before flowing into the crankcase to form the splash system. The partitions between the different troughs in this case are most often pierced by a small hole which will keep a constant level under general conditions and which, in case of a hill, will not allow the oil to flow from one compartment to the other rapidly enough to cause smoking trouble.

**LEVERS ARE OF DIFFERENT TYPES**—It has been said, with more or less truth, that every mechanical device can be resolved down so that in its primitive or elemental form it will be some variation of the lever or inclined plane. The ordinary wheel in

spite of its dissimilarity to the common or garden variety of crowbar is still nothing more or less than a series of these bars which in this case go by the name of spokes; bound together by a rim. The fulcrum in this case being the road, the weight is applied at the axle and the power at various places according to the manner of drive and purpose for which the vehicle is intended.

In any lever there are several things which determine the class to which it belongs; they are the position of the fulcrum or point about which the weight is rotated, the location of the weight and the power which moves it as well as the relative positions of

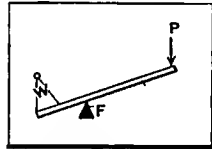

Fig. 6—Illustrating a lever of the first class

all three. There are three different classes of lever which are generally called first, second and third. The first class, shown in Fig. 6, has the fulcrum between the weight and the power, the second, Fig. 7, has the weight between the power and the fulcrum, while the third, Fig. 8, is that in which the power is applied between the fulcrum and the weight.

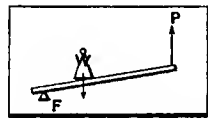

Fig. 7—Typical lever of the second class

The primary and most important purpose of the lever was to apply a greater lifting force to a body than was exerted by the operator of the appliance. It is not to be supposed that there was any gain in total energy, as that would be impossible, but where the gain was made in force applied there was a loss in space traversed, so that aside from the losses by friction in the bearing the number of

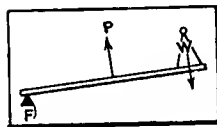

Fig. 8—Lever of the third class, showing relative position of power and weight

foot-pounds applied on the power end of the lever is equal to that applied on the weight end. Secondary uses of the lever have been to reduce motion or to change its direction.

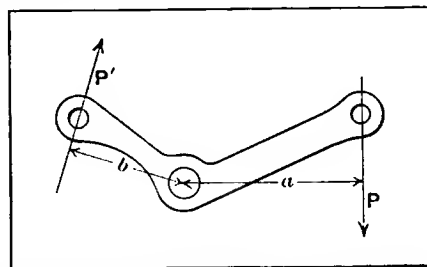

Fig. 9—Bell crank lever showing the direction of the forces P and P' and their respective lever arms, a and b

force with that of reducing the motion. It is in general a lever of the first class as may be seen from Fig. 9, which shows the most common form of this useful device. Referring to this figure, if a force P is applied at one end of the lever in a direction as shown by the arrow which passes through the point of application, and it is desired to convert this force into a force P' acting in the direction indicated by the arrow passing through the other point of application as shown, the two forces will vary inversely as the perpendicular distances between the fulcrum and their line of direction, so that  $P : P' :: b : a$ .

In this way any desired reduction or change in direction may be effected. The amount of force necessary to lift a given weight in any lever, irrespective of the class to which it belongs, may be found by this proportion, which well illustrates the well-known fact that the longer the lever the greater the force which can be exerted on the weight, provided that the weight is relatively near to the fulcrum.

**A WELL-KNOWN KINK**—Apropos of the subject of levers and the great gain in applied force by the use of a long arm, the well-known kink of increasing the turning power of wrench by slipping a piece of pipe

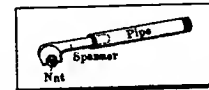

Fig. 10—Placing a pipe over a spanner to obtain greater turning moment

over it may naturally occur to one. In a small bolt where this principle is employed care should be taken that the nut is not stripped by a too violent pull on the part of an over-enthusiastic operator. The accompanying sketch, Fig. 10, gives an idea of the relative length of pipe to spanner for very effective work.

**WHEN GRAVITY FEED IS USED**—In case of a pipe leak of gasoline, which has to be repaired on the road, it is a very uncomfortable feeling which creeps over the driver who has no means of shutting off the gasoline near the tank. A valve should be inserted in the very beginning of the line from tank to carburetor bowl and may be located as shown in Fig. 11. If

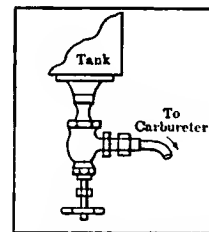

Fig. 11—Position of valve below gasoline tank.

this valve is inserted at the end of the tank it affords an excellent opportunity to place a screen over the opening so that there is plenty of precaution against foreign matter which might have found its way past the filler opening, especially since there are many drivers who regard the straining of gasoline as it is placed into the tank as a waste of valuable time.

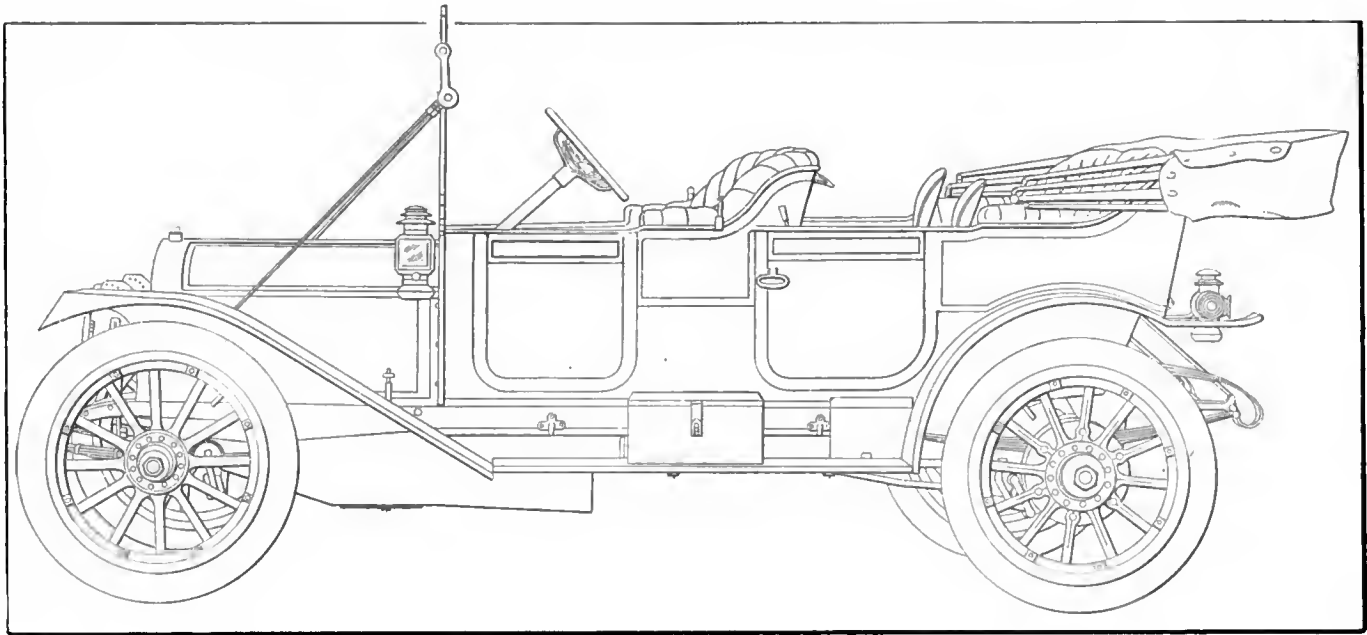

Fig. 1—Side view of the 40-horsepower, seven-passenger, fore-door Corbin touring car, presenting general appearance

## Pertinent Details of the Corbin Characterized by Insignificant Changes

*Whether the automobile has arrived at any degree of finality is a matter that will be left to historians at some later date; but an outstanding feature in the coming season's model of quite a large proportion of the manufacturers of this country shows a decided trend to adhere to the general scheme adopted last year, with whatever improvements and alterations that may have been found necessary or desirable in the light of the year's experience.*

THE preceding remarks may be applied to the product of the Corbin Motor Vehicle Corporation, of New Britain, Conn., manufacturers of the Corbin car. This concern is offering to buyers two models of 40 and 30 horsepower re-

spectively, with six styles of bodywork. In order to differentiate between the two models it is proposed to handle each one separately, so as not to confuse the buyer.

The 40-horsepower model has a four-cylinder motor, with the cylinders cast in pairs, having a bore of 4.75 inches and a piston travel of 5.5 inches. The cylinders are cast from a special gray iron, with integral waterjackets, and are afterward carefully ground to size. The valves are nickel steel, 2.5 inches in diameter, and as the cylinders have T-heads, the former being placed on opposite sides of the motor. The pistons are gray iron and are 6.25 inches long. A large oil groove is machined on the wrist pins, which are made from alloy steel, hardened and ground, being 1.25 inches in diameter. The upper ends of the connecting rods are clamped to the wristpins which oscillate in the piston bosses. The pistons are fitted with four eccentric rings, 1-4 inch wide and provided with diagonal-cut slots. The connecting rods are drop-forgings, of I-section, the big-end bearings being 3.5 inches long.

Fig. 3 shows the lower half of the base chamber with the bottom cover removed, from which can be seen the method of supporting the crankshaft. Three main bear-

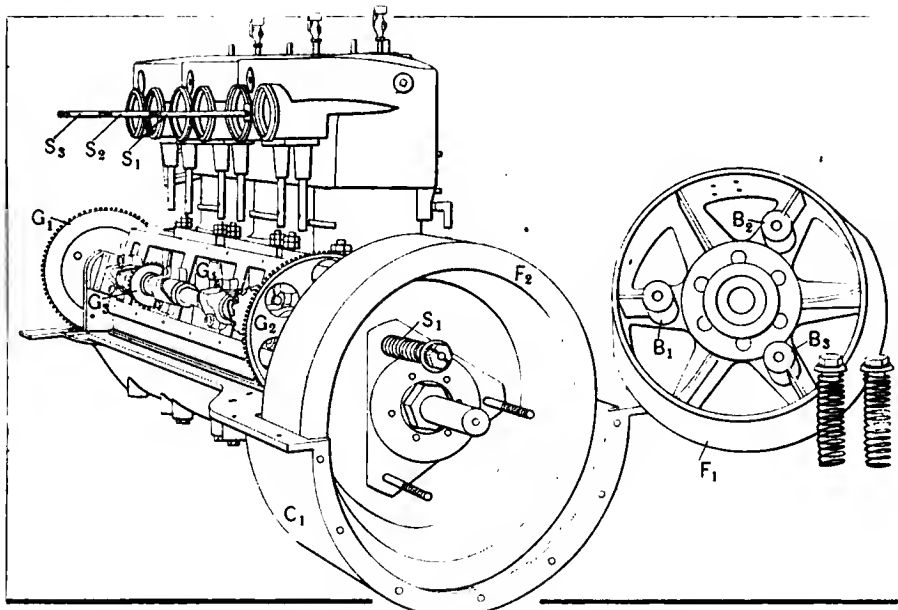

Fig. 2—Showing the 30-horsepower Corbin motor, with the clutch disassembled and valve gear cover removed

ings are employed, the journals of which are 2 inches in diameter, and all bearings are finished by grinding. Front and center boxes C and C2 are 3.5 inches long, while the bearing next to the flywheel is 4.5 inches in length. The crankshaft is an alloy-steel forging with an offset from the perpendicular axis of the cylinders of 1 inch, in order to reduce the angularity of the connecting rods, thereby decreasing the piston thrust on the cylinder walls. The camshaft of the 40-horsepower motor is 15-16 inch in diameter, and runs on three bronze bearings, the front being 3.25 inches long at the point where the strain is greatest, due to the gearing, the center and rear bushings being 2.25 and 2.5 inches in length respectively. The method of driving the camshaft can be seen by referring to Fig. 3, but in this illustration the camshafts, together with their gears, have been removed. The gears utilized for driving the camshafts, pump and magneto shafts are cut with helical teeth from steel blanks.

Fig. 3 shows the method employed of supporting the motor by four arms cast integral with the top half of the crankcase. The lower half of the crankcase can be removed without disturbing the crankshaft bearings and forms a container for the lubricating oil. The oiling system is of the constant circulation type, the lubricant being kept in motion by a gear pump, driven by bevel gears from the exhaust camshaft. A conduit is cored in the sidewall of the upper half of the crankcase, which forms the supply for the main bearings. The surplus oil reaches the crankpins through passageways in the shaft, while a spray or mist thrown by the rapidly revolving crankshaft lubricates the cylinders and other internal parts. It will be noticed that in the base B2 of Fig. 3 there is a square hole, through which the excess oil drains to the lower sump, no lubricant remaining in the case for the connecting rods to dip into.

The motor is cooled by means of a water-circulation system, employing a gear pump driven direct by an intermediary gear wheel off the halftime shaft. The water leaves the bottom of a honeycomb-type radiator and is forced by the pump to the water spaces surrounding the exhaust valve cages, and thence through

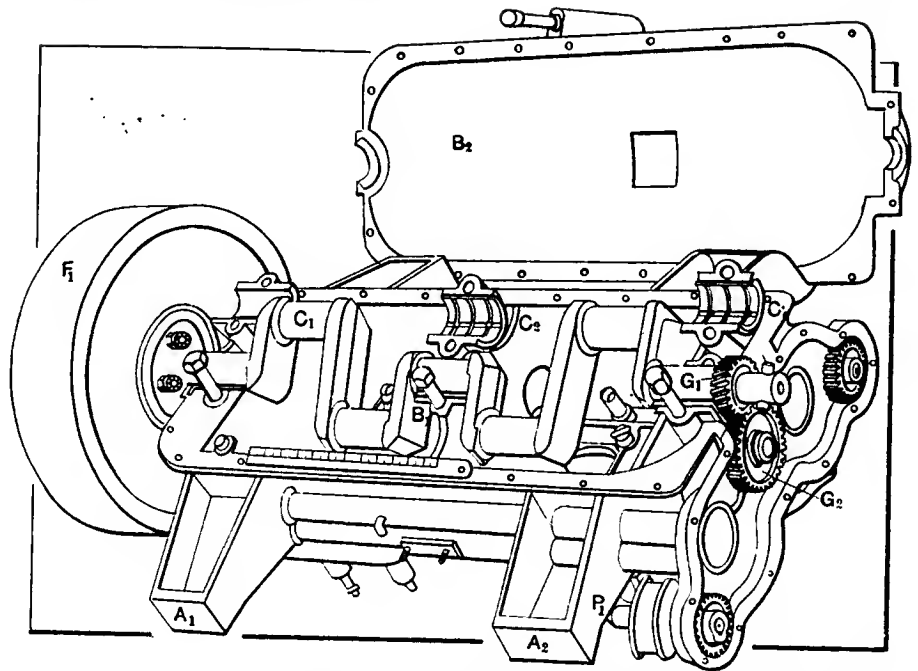

Fig. 3—Looking into the crankcase of the "40" model, with the lower half of the case removed, illustrating crankshaft construction and bearings

the water spaces around the cylinders. The manifolds are well proportioned, the rear portion of the outlet pipe having a bore of 1.125 inches. The cylinder heads have a one-piece cover, secured in position by means of suitable packing and eight studs, and from each of these is led a single pipe. The size of the return flow pipe at the point where the front cylinders discharge their water is increased to 1.5 inches to compensate for the increased flow of water. The manifolds are of brazed construction, of copper piping, and the unions are either ground or fitted with packing flanges. The pump shaft bearing, which carries the stuffing box at the outer end, is 4 inches long, and interposed between the gearing and the pump, attached to the extension of the shaft there is a pulley which serves to drive the six-bladed fan which is mounted on a sliding bracket, driven through the instrumentality of a 1-inch wide, endless, flat belt, the tension of which is maintained uniform at all times.

The ignition is furnished by a U. & H. magneto which rests upon the front supporting arm of the motor, on the intake side. An entirely independent and supplementary ignition is fur-

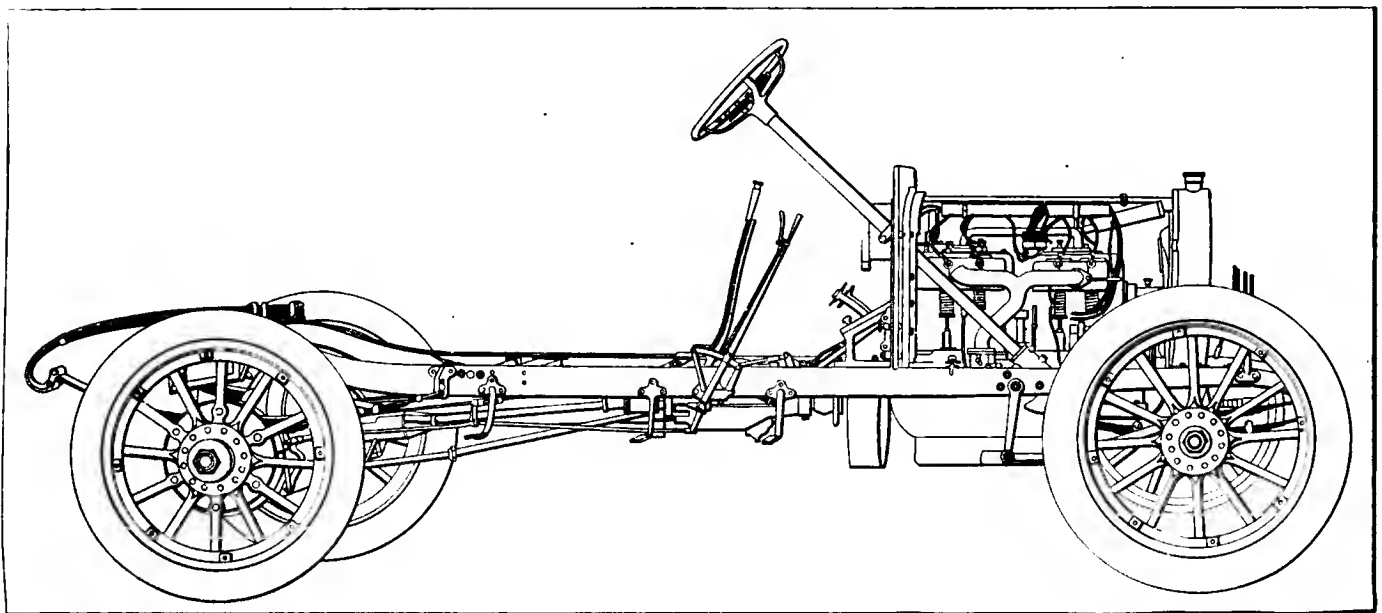

Fig. 4—Chassis of the 40-horsepower Corbin, showing the intake side of motor, steering equipment and substantial design of transmission and suspension

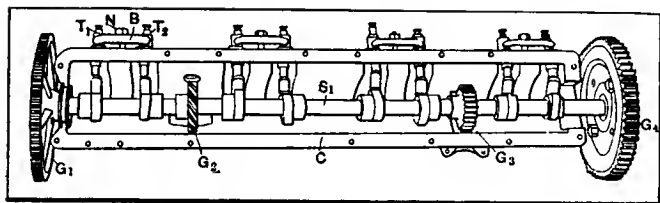

Fig. 5—Camshaft assembly of the 30-horsepower Corbin motor, illustrating the manner of actuating the valves

nished by means of a distributor, in conjunction with batteries and a single-unit coil. The distributor is located between the cylinders on the intake side and is driven by a vertical shaft through bevel gearing off the intake camshaft. A bracket is attached to the rear end of the front pair of cylinders to form a support for the vertical shaft at its upper extremity, and a grease cup is provided to maintain proper lubrication of this part.

The flywheel, which is bolted to the flange on the end of the crankshaft, is 17.5 inches in diameter, and has a female member of the cone clutch machined in the inner periphery of the rim, which is 4.375 inches wide. The clutch is of the cone type, with three separate springs, which transmits the power from the motor to a three-speed gearbox, the shafts being placed horizontally and are carried on annular type ball bearings. The rear axle is of the full-floating type, the main housing is composed of two substantial, pressed-steel members, welded together at the top and bottom by the autogenous process. The differential and driving gearing are supported by a steel casting, and are always maintained in proper relation to each other. The differential with its bevel gear is adjustable with reference to the pinion, and the pinion is also adjustable by a locking collar in front of the pinion bearing, which insures proper meshing of the gears. The propeller shaft connecting the transmission and the differential has two universal joints, and the torque of the rear axle is taken care of by a V-formed torsion bar terminating at its forward end in a spring damper attached to a cross member of the frame. The rear end spans the differential housing and provision is made for an oblique hinge movement.

Two sets of brakes are provided, acting respectively upon the interior and exterior of the brake drums attached to the rear driving wheels. The wheelbase of the 40-horsepower model is 120 inches long, and the thread is standard, 56 inches. The suspension of the pressed-steel chassis, which is narrowed in front, is taken care of by semi-elliptic springs at the forward end, three-quarter-elliptic springs being used at the rear, the back end of the frame having a slight pick-up to adequately take care of this style of suspension.

The Corbin 30-horsepower differs from the larger type in so far that the cylinders are cast with L-shaped heads, the valves being placed side by side and operated from a common camshaft. The bore of the 30-horsepower model is 4.5 inches, while the stroke is slightly less, being 4.25 inches.

The valve lifters are in bronze guides, which can be easily removed, as they are attached to the camshaft housing by double stirrup fittings, held in place by one bolt. The valves are of the nickel steel, head and stem being formed integral. The valve springs instead of being the conventional form are coned at the lower ends and deliver their pressure against a large splitpin passed through the valve stem, no collars or keys being employed. The raising effort of the cam is not taken directly by the plunger, but upon the lower end of the lever interposed between it and the cam. The plungers are fitted with hardened set screws having check nut retention, so that the clearance between them and the valve stems may be accurately maintained.

The entire camshaft assembly is housed in a separate case which forms a unit that can be separately assembled and applied to the side of the motor base, as shown in Fig. 5. The pistons have four rings and two oil grooves. The wristpin is a hollow piece of special steel with hardened surfaces. This is machined on a slight taper and formed in the piston bosses, where

it is retained by a set screw with a pin at the end projecting in the interior.

The connecting rods are forgings of special steel and have hinged lower caps, affording adjustment by tightening one bolt. By removing large plates at the side of the case, these are easily reached for either inspection or adjustment. The upper ends of the connecting rods are bushed with bronze, the lower ends have bearings of white metal.

The cylinders are mounted on an aluminum member, which forms the upper member of a two-part crankcase, surmounting an oil basin of the same material with dual oil pits. The crankshaft bearings are not in the upper half, but in the oil basin, the top portion merely supplying caps for the ball bearings carrying the crankshaft at the outer journals. The lower crankcase member has three intermediate bearings, bushed with white brass, which support the inner three of the five shaft journals.

The oil basin and motor basin are held to the cylinder lugs by long through bolts, the heads being under the oil basin, the nuts on the top of the cylinder base flange. The rear end of the lower half of the engine base spreads to form a shield for the flywheel and clutch, and as the gearset casing is similarly formed at the forward end, it is bolted to the flywheel shield and a unit power plant construction obtained. The front end of the motor assembly is supported by an I-section steel cross-member. Steel plates attached to the chassis frame side-members and extending to the crankshaft not only act as a brace and support of considerable length, but serve to enclose the whole front portion of the chassis.

Lubrication is by a special pump system, the oil supply being carried in a tank above the flywheel. A sliding valve pumps into this supply and forces it through leads to the four cylinders. Splash wells are provided in the crankcase, which are filled by other leads leading from the tank. The three central bearings are fitted with caps, which receive the oil that is splashed up by the connecting rod ends, thereby feeding the main bearings. The clutch and gearbox on this model are almost identical with the 40-horsepower model, but a difference is made in the rear axle which is of the fixed type. The wheelbase is 115 inches. The price of the 40-horsepower model is \$3,000 and the 30-horsepower, \$2,000.

## Selecting an Automobile

*When the average man has decided to buy an automobile after a long and careful consideration of the expense involved and the return either in business or pleasure to be had from the same he generally becomes the victim of not only the ever-alert salesman but also of his best and dearest friends.*

TO the man of moderate means the purchase of an automobile is, like breaking out of jail, a thing not to be lightly undertaken. After a careful consideration of the greatest amount of money which can be invested, he looks about in the manner of all sensible men for the greatest possible value to be obtained for the money. If he is the possessor of friends who own automobiles he invites their opinion and advice as well as that of the sales agents of the concerns who furnish a car at the desired price.

The advice of his friends is apt to be biased, as it is gained from one-sided experience, while the advice of the salesman, although perhaps the result of much experience, is hardly less biased. A demonstration may prove much and it may prove very little, so the prospective automobilist does not know which way to turn. The wise man, however, buys a car of good repute with a solid guarantee, or in the case of a car unknown, has it thoroughly examined by a competent judge.

The style of body purchased will, to a large degree, determine whether the automobilist will be satisfied or disappointed after he has had the machine for a length of time. It is in this feature that the purchaser may rely upon the company from whom he is buying the car, as the great experience of the dealer will aid his judgment in this respect.



# As to the Merits of Vanadium

## Further Pertinent Discussion on the Subject

*In the issue of "The Automobile" of July 27 the criticisms of George L. Norris appeared in reply to an article from the pen of E. F. Lake upon the subject of alloy steels, and incidentally Vanadium, together with E. F. Lake's reply. Mr. Norris again replies to Mr. Lake, quoting chapter and verse, and an opportunity has been given to Mr. Lake to reply.*

### George L. Norris Criticises E. F. Lake's Position

MR. LAKE'S reply to my letter in which I take exception to his statements relative to vanadium opens that I state the article in question "is worthless." I did not make such a statement.

The reason why tests or data to illustrate the beneficial effect of vanadium as a constituent of the steel were not given was simply because it was not considered necessary in view of the great prominence attained by vanadium steels during the past eight or nine years, and the many treatises and articles containing such tests that have been published. The inference that they could not be produced is unwarranted, as previous articles by Mr. Lake and also the 1911 edition of his book on "Composition and Heat Treatment of Steel" prove that he has seen many of these and accepted them as showing that vanadium does add of itself virtues to steel. It would be a pleasure to submit not only the already published tests and opinions of metallurgists of international and local reputation, but also a large amount of unpublished material. I would say that a careful search of the literature of steel fails to reveal any of the countless tests mentioned by Mr. Lake in which vanadium steels failed to nearly approach chrome-nickel steels in static or dynamic qualities.

I know of no metallurgist or steel maker who has investigated or made vanadium steel who has gone on record that "the main mission of vanadium is as a scavenger." Among the investigators are such eminent metallurgists as Arnold, Guillet, Putz, Harbord, Longmuir, Law, Mathews, J. Kent Smith and others. With the exception of J. Kent Smith none of those mentioned refers to or lays any stress on the action of vanadium as a scavenger. This is remarkable when we consider the great amount of work done by such thorough, painstaking and acute observers as Arnold and Guillet, not to mention the others.

J. Kent Smith was undoubtedly the originator of the statement that vanadium is a powerful scavenger, but he never in public discussions made any such statement. Neither have I, as his successor, made any such statement. The literature of our company distinctly states that vanadium exerts its power in at least three ways, one of which is scavenging. It also distinctly states that an extra amount of vanadium must be added for this very purpose. Mr. Lake has this literature and I do not see how he can even carelessly read it otherwise.

How Professor Arnold's positive statement, "Vanadium is undoubtedly the element which, together with carbon, acts with the greatest intensity in the way of improving the iron," can be said to be qualified with a word of doubt is beyond comprehension. Neither is Professor Arnold's expression of opinion of the way vanadium acts or exercises its influence qualified. It is a simple, straightforward statement, or opinion, based on experimental facts available at the time, and never since modified by Professor Arnold in any additional contributions he has made to the literature of vanadium steels. Harbord, in his "Metallurgy of Steels," accepts Professor Arnold's conclusions and uses them without any of the qualifying explanations suggested by Mr. Lake. The statements regarding vanadium steels

in Mr. Lake's book, 1911 edition, revised and corrected, and in previous articles by him on vanadium steels are completely at variance with his statements in his article of June 29 and his reply in THE AUTOMOBILE of July 27. I am at a loss to understand the remarkable change in Mr. Lake's opinion of vanadium as shown by the following statements:

AUTOMOBILE, June 29, 1911.

"Vanadium of itself adds no virtues to steel. When it has cleansed the steel of impurities it has performed its mission; thus, it is as well to allow it to go off into the slag as to try to keep any in the steel.

"Of the vanadium steels very little, if any, vanadium is present in the finished product, and hence vanadium steel is a misnomer."

AUTOMOBILE, July 27, 1911.

"Vanadium of itself adds no virtues to steel. In trying to refute this statement, he (Mr. Norris) says, 'The experience of a large number of steel manufacturers is overwhelmingly opposed to this statement—it is a question of having the vanadium in the steel because by countless tests it has been proved that vanadium produces definite beneficial results. Why has he not submitted one of these?' This element (titanium) will give practically the same results that are obtained with vanadium, and its growing competition may be the cause for the claims that vanadium of itself, in the proper percentages, adds to the static and dynamic properties of steel."

AUTOMOBILE, July 27, 1911.

"Countless tests have been made with vanadium-treated steels in comparison with other steels, but not one of these tests has shown us that vanadium-treated steels equal either the static or dynamic properties of chrome-nickel steel; in most cases they could not nearly approach it."

AUTOMOBILE, July 27, 1911.

"Neither in my original article nor in this answer to Mr. Norris have I said that vanadium did not produce beneficial results when properly alloyed and used in the correct proportions.

"Composition and Heat-Treatment of Steel,"

1911, page 104.

"Vanadium has made great strides in the past few years as an alloying element, and is used in steel castings, cast iron, and the bronzes and brasses as well as in steel mill products."

Page 119.

"Vanadium has given such good results in rolled steels that it has been taken up by some of the steel foundries." (Then follows a comparative test very favorable to vanadium.) "Before adding vanadium in the furnace it is necessary to have the oxides all removed from the metal as vanadium has a great affinity for oxygen. If any of the oxides remain in the metal, the vanadium will scavenge them out and go off in the slag; but as vanadium is too expensive to use as a scavenger, the oxides should be removed as completely as possible before it is added to the steel." "Many failures in the use of vanadium in the past have been due to this elusiveness, or its affinity for oxygen, etc. As a matter of fact, it might have completely oxidized out of the metal and not given it any of the desirable properties of which it is capable."

"Vanadium Steel" — Machinery, Oct., 1907.

"While vanadium affects steel in a manner that tends to increase the static strengths of other alloys, it also raises the dynamic properties to an extent that is not thought of in other alloys." (This article also contains numerous tests and illustrations demonstrating the beneficial effects of vanadium when alloyed with chromium, etc.

"Composition and Heat-Treatment of Steels,"

Page 123.

"A chrome vanadium steel will give as great strength as a nickel-chrome and can be forged as easily as a 0.40% carbon steel."

Pages 99 and 100.

AUTOMOBILE, July 27, 1911.

"The mere statement that a large number of steel manufacturers are producing vanadium steels regularly proves nothing except that they are supplying a demand."

"When chrome is combined with nickel or vanadium it makes the strongest, toughest and best wearing steel on the market, etc."

"The nickel-chrome steels are difficult to forge—it must be heated many times to forge pieces of any size of intricate shape." (The demand for vanadium steels is explained by the above.)

The usual loss of vanadium in steelmaking, excepting the electric furnace process, where there is no loss, is from 10 per cent. to 20 per cent. Now, if the steel maker can attain all the benefits possible through the scavenging action of vanadium and only wants to leave it in to prove to the chemist that it was used, why does he leave in three or four times as much as the chemist can readily determine? In protective deckplate where no chemical proof is required—because the Government does not distinctly specify composition, only physical and ballistic tests—I am assured by the manufacturers that they cannot meet the requirements if they use vanadium solely as a scavenger, or do not exceed a certain percentage in the steel. I am assured by other steel makers that such has also been their experience.

In the manufacture of electric furnace steel vanadium does not act as a scavenger, it cannot, owing to the highly reducing conditions in the furnace. If added in the form of vanadium oxide it would be reduced. All the vanadium added to an electric furnace is found in the steel. This I know from my own experience, and also by reports from electric steel makers. There is no reason to expect that because metals are melted or refined in an electric furnace their metallurgical, chemical or physical qualities will be radically changed, in fact, the electric steel makers of to-day are simply claiming equality with crucible steel. I have under way an extensive series of tests covering open-hearth steel, both basic and acid, crucible and electric furnace steels, with and without vanadium, and I can assure Mr. Lake that the electric furnace steels are showing the same relative improvement through the use of vanadium as the steels made by the other processes.

In a lecture before the Franklin Institute, May, 1909, after three years' experience with electric-furnace steelmaking, Dr. John Mathews makes the following statement: "The chrome-vanadium alloys are preferably made in the crucible or electric furnace, although the open-hearth process is also much used for the purpose." "By judicious blending of chromium and vanadium and adjustment of the manganese and carbon, one can not only obtain all static properties that can be obtained from nickel, chrome-nickel or silico-manganese alloys, but in addition obtain dynamic or anti-fatigue qualities far in excess of those displayed by any other alloys. In general, nickel-chrome steels possess excellent static qualities, but the difficulties in heat-treatment, forging and machining lead one to prefer the other types of alloys previously mentioned." "The number of alternations of stress to produce fracture gives a measure of vitality, so to speak. Average results of a great many tests made in this way of crucible carbon springs, chrome-nickel, silico-manganese and genuine crucible chrome-vanadium springs proves the extraordinary quality of the last-named product. The average figures for alternations were as follows: Crucible carbon spring, 150,000; chrome-nickel and silico-manganese, each 200,000; chrome-vanadium, 5,000,000 and still unbroken."

Longmuir in May, 1909, presented a paper before the British Iron and Steel Institute on "High-Tension Steels," in which direct comparisons were made with nickel steels, chrome nickel steels and chrome-vanadium steels. It happens that one of the chrome-nickel steels has approximately the same composition as Mr. Lake's ideal steel:

	Longmuir.	Lake.
Carbon	0.30%	.25%
Nickel	5.00%	4.50%
Chromium	1.00%	1.50%

The physical properties of this steel are given in the following table:

No.	Condition.	TREATED CHROMIUM-VANADIUM STEELS			
		Elastic limit, tons per sq. in.	Maximum stress, tons per sq. in.	Elongation, per cent on 2 in.	Reduction of area, per cent.
31	Treated, i.e., quenched in water from 850°	59.63	66.23	16.0	38.6
32	quenched in water from 850°	52.42	61.16	18.0	41.6
33	C. to 900° C., and tempered at 550° C.	59.74	64.28	19.5	47.2
34	C. to 900° C., and tempered at 550° C.	56.70	63.66	20.0	43.4
35	550° C.	55.08	61.88	21.0	45.4

Compare with this the physical properties given of a chrome-vanadium steel of practically the same carbon: Carbon, 0.32 per cent.; chromium, 1.10 per cent.; vanadium, 0.16 per cent.

No.	Test cut from	Elastic limit, tons per sq. in.	Maximum stress, tons per sq. in.	Elongation, per cent on 2 in.	Reduction of area, per cent.
56	1-in. diameter bar	63.48	67.68	17.0	.....
57	Crank	56.44	64.78	15.0	.....
58	Axle	61.34	67.32	17.0	33.6
59	Axle	56.16	63.12	22.0	47.2

Mr. Longmuir's conclusions are: "The work done shows that nickel steels do not give the high values obtained from nickel-chromium, or chrome-vanadium. The last two represent exceptionally good types of high-tension steels, but for all-around properties chrome-vanadium gives the best results."

The above tests practically confirm the statement in Roscoe & Schorlemer's treatise on chemistry, that "vanadium acts in a similar manner to nickel, but is much more efficient, 0.20 per cent. producing the same effect as 3 to 4 per cent. of nickel."

I can assure Mr. Lake that the "growing competition" of titanium as a scavenger is not "the cause for the claims that vanadium of itself, in the proper percentages, adds to the static and dynamic properties of steels." These claims for vanadium have been made from the very beginning by disinterested investigators of high standing.

Mr. Lake Answers Mr. Norris' Second Criticism

The tone of Mr. Norris' second criticism has been considerably changed, and in it some evidence and data are given on which a discussion can be made as to the real merits of the case. To merely say that "the great prominence obtained by vanadium steel during the past eight or nine years was the reason why no tests or data were given" is to dodge the issue. To say "it would be a pleasure to submit not only the already published tests and opinions of metallurgists of international and local reputation but also a large amount of unpublished material" proves nothing, unless more than opinions are submitted. It is a bold assertion when he says, "the inference that they could not be produced is unwarranted" if facts are not produced.

When he says "a careful search of the literature of steel fails to reveal any of the countless tests mentioned by Mr. Lake in which vanadium steels failed to nearly approach chrome-nickel steels in static or dynamic qualities" it might be that none of these had been recorded and brought to his attention. On the other, hand, in the large amount of research work I have done since vanadium came into commercial use, I have failed to find any reliable tests where vanadium steels equaled, much less excelled, the physical properties of chrome-nickel steel that was properly made and heat-treated. One or two instances have been given such as Mr. Norris submits in the latter part of his discussion when he says, "The average figures for alterations were as follows: Chrome-carbon spring, 150,000; chrome-nickel and silico manganese, each, 200,000; chrome-vanadium, 5,000,000 and still unbroken."

These figures would indicate to me that, either a very poor grade or an improperly heat-treated chrome-nickel steel was used when it only showed 200,000 alternations. I have seen chrome-nickel steel withstand 2,250,000 alternations and have heard of other tests that gave better results than this. I have also seen steels tested on the White-Souther's rotary vibrational machine in which an open-hearth low carbon steel withstood 2,660,000 revolutions, while steel that was very similar to the vanadium products withstood a little over 25,000,000 revolutions at the same fibre stress. While this comparison was between a low-grade, cheap steel, and a high-grade one, it only made one about ten times greater than the other. In Mr. Norris' comparison, however, it is to be supposed that the chrome-vanadium and chrome-nickel steels are both of the highest grade and properly heat-treated. Therefore, to make one withstand 25 times as many alternations as the other seems beyond reason and unbelievable. Such a difference could not exist unless test bars from the very best grade of chrome-vanadium steel were used to compare with those from a very poor grade of chrome-nickel steel or unless the heat-treatment was such as would make one steel fail long before the other, or both.

Since Roscoe separated the element vanadium in the '60's much experimental work has been done. It is only within the last decade, however, that vanadium has had a commercial application in practical steel making. Of the metallurgists whom Mr. Norris mentions as investigators of vanadium, J. Kent Smith is the only one that has specialized on this subject. The others have spent most of their time working on other steels and have doubtless accepted Mr. Smith's statement that "vanadium is a powerful scavenger." It might be added that this was the only statement that Mr. Smith emphasized. When Mr. Norris says, "I know of no metallurgist or steel maker who has investigated or made vanadium steel, who has gone on record that the main mission of vanadium is as a scavenger," I might say I know of none who have said that the main mission of vanadium is *not* that of a scavenger. After these two seemingly opposite statements have been made, nothing is gained and those selling the alloy might be the only ones to contradict either statement. Even at that they might both be true.

The comparative tests that the makers' literature has given me are all between carbon steel, nickel steel and vanadium steel. In most of these, chrome-vanadium steel has been compared with Government nickel steel, or in other words, the highest type of vanadium steel has been compared with a nickel steel that is not of the highest type. When this fact was presented to J. Kent Smith in July of 1907, he informed me that experiments were being conducted to show the physical and dynamic differences between chrome-nickel and chrome vanadium steel. As four years have elapsed and none of this data has been given out, I am perfectly justified in forming the conclusion that the tests did not show superior results for vanadium. Therefore, I again say that none of the vanadium steels equal the chrome-nickel steels in physical properties.

Mr. Norris says, "I have under way an extensive series of tests covering open-hearth steel, both basic and acid, crucible and electric furnace steels, with and without vanadium; and I can assure Mr. Lake that the electric furnace steels are making the same relative improvement through the use of vanadium as the steels made by the other processes." This again is only a statement without any data or facts being given to prove the assertion and until such data is forthcoming, we have the right to express our doubts.

While we know that great improvements can be made in certain grades of steel by the addition of vanadium, we still hold to the opinion that the high-grade chrome-nickel steels are the superior of vanadium steels. While there have been many exaggerated statements made in regard to vanadium, it is a rare thing for anyone to claim that the vanadium steels equal the chrome-nickel steels in physical properties. Investigations or experiments to prove this are also seldom made. From all the evidence I can gather, well-made vanadium steels are excellent material and probably the chrome-nickel steels are the only ones that excel them. The vanadium steels are much easier to machine than nickel-chrome steel and as they sell for a lower price, they are excellent steels for automobile uses.

It is impossible for one man to investigate all kinds of steels thoroughly or to know everything about steel. Thus the statements of others have to be accepted when they appear to be correct. That there is a great deal of commercialism in the steel business and that many a good metallurgist has had his opinions biased by this commercialism cannot be denied any more than it can be denied that the noted chemist Dr. Wiley encountered troubles when he tried to make the prepared food companies leave poisons out of the foods. To do so meant some loss of profits to the companies and thus an attempt was made to remove him.

From the commercial metallurgists, we are liable to get data, results of tests, etc., that only tell part of the truth. This often misleads others who are earnestly seeking for facts and at times might cause them to make false statements unknowingly. There is so much commercialism in the steel industry that it is very difficult to get at any real facts in regard to data,

tests, etc., or any just comparisons of different grades of steel.

Then again, investigations and discoveries are being made every day that upset former theories and opinions that appeared to be facts. No man has yet lived who did not change such opinions when presented with data that disproved them. Because a man said something in the last century, the last decade, last year, last month or even yesterday, it is absolutely correct, is a very false principle on which to establish an argument. This argument, therefore, should be based on what is and not on what has been.

Because I said a certain chrome-nickel steel gave good results, it does not warrant Mr. Norris in branding it "Mr. Lake's ideal steel," as there are many other compositions of chrome-nickel steel that might give as good, if not better, results. The improvements that are continually being made do not make me desirous of calling any particular composition my ideal steel. Then again it is not fair to compare it with Longmuir's steel that contains 1-3 less chromium, 1-9 more nickel and 1-5 more carbon. When this is done, however, it does not show any great difference in their tensile properties and does not attempt to show any difference in their alternations.

While I do not like to bring others into this discussion, Mr. Norris has twice quoted Dr. John A. Matthews. Within one month, either way, from January 1, 1908, I talked with Dr. Matthews in Syracuse, N. Y. At that time he was very much opposed to vanadium and severely criticised some of the statements I had made in regard to it, and which Mr. Norris is now quoting from *Machinery*, October, 1907. There was no electric furnace in the plant with which Dr. Matthews was connected. In May, 1909, he delivered the lecture Mr. Norris mentions. In the Halcomb steel plant, of which Dr. Matthews was then president, an electric steel-making furnace was located. It was one of the first that had been installed in this country and was in very poor condition when he took hold of it, as the former management had made it a failure. Thus instead of three years' experience with electric furnace steel making, as Mr. Norris says, Dr. Matthews had less than half of that at the time he delivered the lecture that Mr. Norris quotes from.

That vanadium produces some very good results when used in steel making cannot be successfully denied. Whether it has completed its mission when it acts as a scavenger or whether it adds, of itself, certain properties to steel, is a much disputed question. That I take the former position is due to the fact that this has been thoroughly demonstrated. The latter position, however, needs a great deal more data to prove the theories advanced and until this data is forthcoming I cannot accept Mr. Norris' theory. In either case, however, it is more of an argument for the metallurgists and steel makers than for the readers of *THE AUTOMOBILE*. They are more interested in the practical results obtained from the metal than in the eutectic, solid solution, oxidizing, scavenging or other forms or reactions the elements may enter into in the manufacture of the product.

That oxygen, nitrogen and hydrogen are present in steels in larger percentages than have formerly been supposed and that these are as injurious to the metal as phosphorus and more injurious than any of the other elements, has now become well recognized. That these may take the form of occluded gases, or microscopic bubbles, or segregate in quantities sufficient to produce holes large enough to be seen with the naked eye, termed blow-holes, is an undisputed fact. That they unite with other elements and cause these to injure the metal is also fast becoming recognized.

These gases are present in the largest percentages in steels made by the Bessemer process; open-hearth steels are second in the percentage of gases present, with crucible-made steels third, and electric steels fourth. In the electric furnace they can be reduced to very low percentages, owing to the ability to protect the liquid bath from the atmosphere and also to use slags that will keep them out or cause their removal. Steels made with the crucible process are not very high in these gases, as the crucibles are sealed up and thus protected from the outside air.

With any of these processes, unless it be the Bessemer, "vanadium can be properly alloyed and used in the correct percentages" to remove the larger part of the gases left after the steel has been refined by other methods, and proved on chemical analysis that it is a vanadium steel. This in no way contradicts my statement in THE AUTOMOBILE of June 29, when I said "vanadium of itself adds no virtues to steel, etc." When thus used the vanadium will greatly increase the static strengths of the metal, bring the elastic limit up close to the tensile strength and add greatly to the dynamic properties. To expect to make any of these twenty-five times what the metal formerly was is expecting altogether too much. If they are doubled or trebled, a great improvement has been made and the alloying material is well worth its cost.

That greatly increased physical properties can be obtained in steels that are carefully made in any of the steel-making processes over the ordinary commercial steels that can be turned out is as much a fact as that much better and finer work can be made in any other manufacturing line if time enough is taken to do so. Tests are often made with a specially prepared steel of a given kind and comparisons made with it from stock steels of noted brands. Such comparisons cannot help but be misleading and produce unfair comparisons.

The impurities, which are the real weakening elements of steel, can be much more readily removed in a small furnace making a small batch, or heat, of metal than in a large furnace making a large one, and it is therefore unjust to compare the physical properties of one steel made in a small heat and another steel made in a large one, no matter what the method or process by which it is made. It is too often the case that our comparative tests are obtained in this way.

### When Turning a Curve

*When rounding a curve with a heavy automobile there are a number of stresses set up in the car at any speed. These stresses become more severe as the speed increases, but the strains increase in intensity with the square of the speed, so that a little added speed means greatly augmented stresses.*

AN automobile to be safe must, under all conditions, be in a state of stable equilibrium. This is a condition which is very simply maintained when the car is standing still, or when running at moderate speeds along a level road, but when a sharp turn is negotiated at high speed the matter becomes of an entirely different nature. Referring to Fig. 1, two roads of width S are depicted crossing each other at right angles. In turning from one into the other a turn of radius R is made, this radius being very nearly equal, as a rule, to the width of the road. As the car goes around this curve it is acted upon

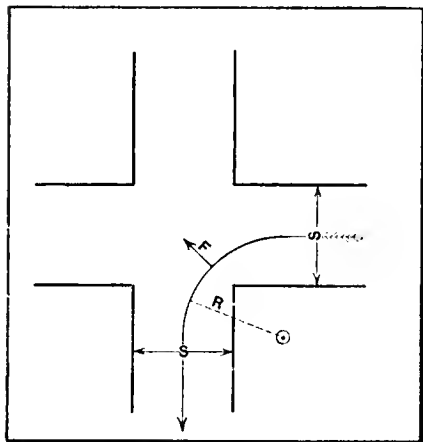

Fig. 1—Diagram of course usually taken in rounding a curve—S is the width of the road. R the radius of the curve and F the direction of the centrifugal force

by a force which tends to throw it away from the center in the same way that a ball tied upon a string and swung around will tend to break the string and fly away from the hand which is swinging it. This force is called the centrifugal force, and its pull in pounds is denoted in the figure by F.

In a body which is subjected to the stresses of weight and centrifugal force, they may be figured as acting at the center

of gravity of that body. So that it is easy to see that when the car is subjected to the force due to its turning the curve, there is a marked tendency for it to turn over, the amount of which is measured in foot-pounds by the product of the centrifugal force in pounds and the height of the center of gravity of the car from the ground in feet. Referring to Fig. 2, let G be the center of gravity of the car, F the centrifugal force in pounds, a the height of the center of gravity above the ground in feet, b one-half the tread or the distance of the center of gravity from the point of contact of the wheel with the ground, measured horizontally. W is the weight of the machine acting vertically downward from the center of gravity, A and B are the points of contact of the wheels and the ground. As the car is turning a curve the righting leverage must be greater than the upsetting moment to keep the car in stable equilibrium; that is, Wb must be greater than Fa. In case the car should turn over, owing to the fact that Fa was greater than Wb, it would turn over about A, the outside wheels.

The speed at which the two moments are equal in turning a curve of given radius is called the critical speed. At this point the car is in neutral equilibrium; that is, if it should be slightly inclined, it would tend to fall still further out of the perpendicular instead of tending to return to its normal position. This speed can be determined by equating the two moments and solving for the speed, as follows:

Let  $aF = bW$  (Fig. 2).

$$F = \frac{Wv^2}{gR} \text{ therefore } \frac{aWv^2}{gR} = bW \text{ and } v^2 = \frac{bgR}{a} = 32.16 \frac{bR}{a} \quad (1)$$

where the symbols are as described above for Fig. 2—and v is the critical speed.

From the last equation it is seen that the greatest possible speed in turning a curve varies directly with b and R, and, inversely, with a. That is, it would be greater to maintain a greater speed around a given curve of radius R without overturning if the tread of the wheels or the radius of the curve were greater or the center of gravity of the car were nearer to the ground.

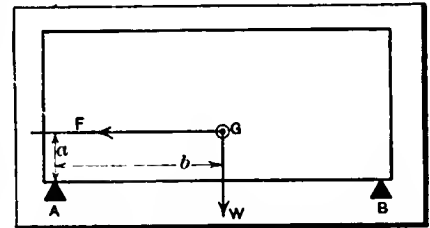

Fig. 2—Illustrating the upsetting and righting moments—G is the center of gravity, F the centrifugal force, W the weight of the car, a the upsetting arm, b the righting arm. A and B are the points of support

From the above it is seen that the weight factor is not of any influence in so far as the turning over of the car is concerned, since it is on both sides of the equation point. We are all aware though, that a light car will not "hold the road" as well as a car of greater weight. This is not because of its turning over on account of rounding a curve, but due to the side-slipping of the car which introduces entirely different factors. In this case the car is given a momentum away from the center of the road because the centrifugal force F is greater than the resistance to sliding of the wheels. To maintain equilibrium all forces must be balanced by equal and opposite forces. Hence the force F will have to be counteracted by the frictional resistance set up between the tire and the road which will be measured by the weight multiplied by the coefficient of friction. If the coefficient of friction is f, the critical point of side slipping

will be reached when  $fW = F$  or  $f = \frac{F}{W}$ . To determine the

valuations of the different factors in a practical case, an example may be taken to show both the inclination of the car to turn over and to side slip.

Let W be 3,000 pounds; R, 20 feet; a, 2 feet; b, 2 1/3 feet, and v, 22 feet per second: F will equal  $\frac{Wv^2}{gR}$  or  $\frac{3000 \times 22 \times 22}{32.16 \times 20} =$

2257 pounds. This side pull  $F$ , exerts a turning moment over the outside wheels of  $aF$  foot-pounds or, in the above case of 4514 foot-pounds, which is resisted by the moment of the weight of the car about the outer wheels  $bW$ , which is equal to 7000 foot-pounds in this case. This leaves a margin of safety of about 2500 foot-pounds in the case considered. To find the critical speed of this car going at the above speed around the same curve, 7000 foot-pounds must be equated to  $aF$  or from

$$v = \sqrt{\frac{32.16 \times 2.33 \times 20}{2}} = 27.4$$

feet per second. That is, the car would turn over at a speed in excess of 27.4 feet per second, or 18 2-3 miles an hour, approximately.

Besides turning over the tendency of the car to slip sideways may be measured mathematically by equating the side pull  $F$ , which in the above case is 2257 pounds, and the frictional resistance of the road to the side slipping, which is measured by  $fW$  where  $f$  is the coefficient of friction, and is a constant for given road conditions. Equating:  $3000 f = 2257$  or  $f = \frac{2257}{3000} =$

.752. That is, if under the given conditions the coefficient of friction were .752, the car would be just on the point of slipping. It is seen that with a fixed coefficient of friction the resistance to side slipping depends directly upon the weight of the car.

While from a theoretical point of view the side slipping of the car would continue until the radius of the curve were changed or the road conditions were different, the skillful driver

offsets the tendency by a skillful manipulation of the steering wheel, and the slipping is often confined in this manner to one pair of wheels; it is then known as a skid. In this case one set of wheels act as a pivot for the other pair. The skidding tendency is checked in many cases by disengaging the clutch and releasing the brakes so that the wheels are free to turn. On wet and slippery days when the coefficient of friction will be reduced to a minimum, the greatest danger ensues and curves are of necessity negotiated at the lowest possible speeds.

Two ways in which the life of the car or its parts may be made as long as possible in connection with driving around curves are throwing out the clutch and in maintaining the tires at the required pressure. The former is for the purpose of preventing unnecessary torsional stresses in the transmission and the latter to cut down the tire bills, which are always a little larger than the average motorist desires. Fig. 3 shows the distortion which takes place in a soft tire when turning a curve. Recurring strains of this kind will soon spoil the best of tires.

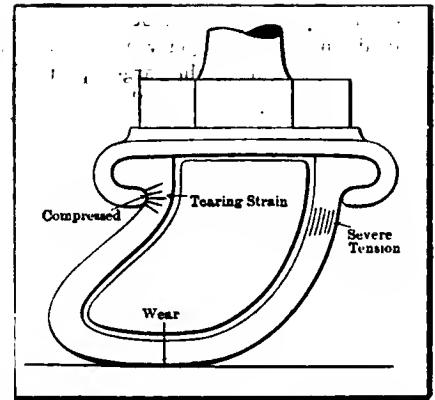

Fig. 3—Showing the strain on a soft tire in rounding a curve. The points of severest stress are indicated.

# Calendar of Coming Events

## Handy List of Future Competitive and Show Fixtures

### Shows

- Jan. 1-5, 1912.....New York City, Grand Central Palace, Annual Show, Automobile Manufacturers' Association of America.
- Jan. 6-13.....New York City, Madison Square Garden, Twelfth Annual Show, Pleasure Car Division, Automobile Board of Trade.
- Jan. 10-17.....New York City, Madison Square Garden, Annual Show, Motor and Accessories Manufacturers.
- Jan. 10-17.....New York City, Grand Central Palace, Twelfth Annual Show, National Association of Automobile Manufacturers.
- Jan. 15-20.....New York City, Madison Square Garden, Twelfth Annual Show, Commercial Division, Automobile Board of Trade.
- Jan. 27-Feb. 10.....Chicago Coliseum, Eleventh Annual Automobile Show under the auspices of the National Association of Automobile Manufacturers.

### Race Meets, Runs, Hill-Climbs, Etc.

- Sept. 1.....Oklahoma, Reliability Run, *Daily Oklahoman*.
- Sept. 2.....Pottstown, Pa., Track Races, South Jersey Motor Club.
- Sept. 2, 3, 4.....Kansas City, Mo., Track Races, Automobile Club of Kansas City.
- Sept. 2-4.....Amarillo, Tex., Track Races, Panhandle Auto Fair Association.
- Sept. 2-4.....Brighton Beach, N. Y., Track Races.
- Sept. 3.....Columbus, O., 200-mile Race, Columbus Automobile Club.
- Sept. 4.....Scranton, Pa., Track Races, Automobile Association of Scranton.
- Sept. 4.....Denver, Col., Track Races, Denver Motor Club.
- Sept. 4.....Salem, N. J., Track Races, South Jersey Motor Club.
- Sept. 4, 5, 6.....Old Orchard, Me., Beach Races, Old Orchard Automobile Association.
- Sept. 6.....Detroit, Mich., Reliability Run, Wolverine Automobile Club.
- Sept. 6-9.....Buffalo, N. Y., Grade I, Reliability Run, Automobile Club of Buffalo.
- Sept. 7-8.....Philadelphia, Track Races, Philadelphia Auto Trade Association.
- Sept. 8-9.....Hamline, Minn., Track Races, Minnesota State Automobile Association.
- Sept. 9.....Augusta, Me., Hill Climb.
- Sept. 9.....Cincinnati, O., Road Race, Fern Bank Dam Association.
- Sept. 9.....Hartford, Conn., Track Races, Connecticut Fair Association.
- Sept. 9.....Port Jefferson, L. I., Hill Climb, Port Jefferson Automobile Club.
- Sept. 9.....Riverhead, L. I., Road Race, Port Jefferson Automobile Club.
- Sept. 13.....Grand Rapids, Mich., Track Races, Michigan State Auto Association.

- Sept. 15.....Knoxville, Tenn., Track Races, Appalachian Exposition.
- Sept. 16.....Syracuse, N. Y., Track Races, Automobile Club and Dealers.
- Sept. 18-20.....Chicago, Ill., Commercial Reliability Run, Chicago Motor Club.
- Sept. 19.....Burlington, Vt., Reliability Run, Merchants' Protective Association.
- Sept. 23.....Philadelphia (Point Breeze), Track Races, Philadelphia Automobile Trade Association.
- Sept. 23-25.....Detroit, Mich., Track Races, Michigan State Agricultural Society.
- Sept. 25-30.....Atlantic City, N. J., Convention and Exhibition of the Carriage Builders' National Association.
- Sept. ....Denver, Col., Track Races, Denver Motor Club.
- Sept. ....Steubenville, O., Hill Climb, Automobile Club of Jefferson County.
- Oct. 6-13.....Chicago, Ill., Thousand-Mile Reliability Run, Chicago Motor Club.
- Oct. 7.....Danbury, Conn., Track Races, Danbury Agricultural Society.
- Oct. 7.....Philadelphia, Fairmount Park Road Races, Quaker City Motor Club.
- Oct. 7.....Springfield, Ill., Track Races, Springfield Automobile Club.
- Oct. 13-14.....Atlanta, Ga., Track Races.
- Oct. 14.....Santa Monica, Cal., Road Races.
- Oct. 14 (to 25).....New York City, Start of the Annual Glidden Tour, en route for Jacksonville, Fla.
- Oct. 16-18.....Harrisburg, Pa., Reliability Run, Motor Club of Harrisburg.
- Nov. 1.....Waco, Tex., Track Races, Waco Auto Club.
- Nov. 2-4.....Philadelphia, Reliability Run, Quaker City Motor Club.
- Nov. 4-6.....Los Angeles, Phoenix Road Race, Maricopa Auto Club.
- Nov. 9.....Phoenix, Ariz., Track Races, Maricopa Automobile Club.
- Nov. 9, 10, 12.....San Antonio, Tex., Track Races, San Antonio Auto Club.
- Nov. 27.....Savannah, Ga., Vanderbilt Cup Race, Savannah Automobile Club.
- Nov. 30.....Los Angeles, Cal., Track Races, Motordrome.
- Nov. 30.....Savannah, Ga., Grand Prize Race, Savannah Automobile Club.
- Nov. ....Columbia, S. C., Track Races, Automobile Club of Columbia.
- Dec. 25-26.....Los Angeles, Cal., Track Races, Motordrome.

### Foreign Fixtures

- Sept. 2-11.....Roubaix, France, Agricultural Motor Vehicle Show.
- Sept. 9.....Bologna, Italy, Grand Prix of Italy.
- Sept. 10-20.....Hungarian Small-Car Trials.
- Sept. 16.....Russian Touring Car Competition, St. Petersburg to Sebastopol.



# THE AUTOMOBILE

Vol. XXV

Thursday, August 31, 1911

No. 9

## THE CLASS JOURNAL COMPANY

H. M. SWETLAND, President  
A. B. SWETLAND, General Manager  
231-241 West 39th Street, New York City

### EDITORIAL DEPARTMENT

GEORGE M. SCHELL

JAMES R. DOOLITTLE  
J. EDWARD SCHIPPER

HUGH P. MacCONNELL  
HANS WEYSZ

### ADVERTISING DEPARTMENT

W. I. RALPH, 1035 Old South Bldg., Boston  
C. H. GURNETT, 910 South Michigan  
L. G. VOGEL, Avenue, Chicago  
T. B. VAN ALSTYNE, New York and Phila.  
H. L. SPOHN, New York

LOUIS R. SMITH, New York  
FRANK B. BARNETT, 309 Park  
Building, Cleveland  
H. H. GILL, 627 Ford Building,  
Detroit

Cable Address - - - - - Autoland, New York  
Long Distance Telephone - - - - - 2046 Bryant, New York

### SUBSCRIPTION RATES

United States and Mexico - - - - - One Year, \$3.00  
Other Countries in Postal Union, including Canada - - - - - One Year, 5.00  
To Subscribers—Do not send money by ordinary mail. Remit by Draft,  
Post-Office or Express Money Order, or Register your letter.

### FOREIGN SUBSCRIPTION AGENTS

ENGLAND:—W. H. Smith & Sons, Ltd., 186 Strand, London, W. C., and all book-  
stalls and agencies in Great Britain; also in Paris at 248 Rue de Rivoli.  
FRANCE:—L. Baudry de Saunier, offices of "Omnia," 20 Rue Duret, Avenue  
de la Grande Armee, Paris.  
GERMANY:—A. Seydel, Mohrenstrasse 9, Berlin.

Entered at New York, N. Y., as second-class matter.

The Automobile is a consolidation of The Automobile (monthly) and the Motor  
Review (weekly), May, 1902, Dealer and Repairman (monthly), October, 1903,  
and the Automobile Magazine (monthly), July, 1907.

### THE ELGIN RACES

EVERYBODY connected with automobiling from a manufacturing as well as from a sporting point of view regrets the fatal accidents in connection with the national stock chassis races held last week on the Elgin circuit. These accidents arouse tremendous attention from ocean to ocean, but the saner element always deplores them. We can only mount to higher levels by profiting by the errors of the past, and every accident should be an object lesson to every manufacturer. The two Elgin accidents were peculiar. One that happened in practice remains a mystery. It occurred on a perfect stretch of roadway without a ditch on either side where the car ran onto the grass. The other accident on race day was also on a perfect roadway with ample width. In both cases a tire exploded, the car took the ditch and finally capsized in getting onto the roadway again. In a word the tire was the prime cause of the accident.

Tires will explode; the terrific heat generated by the fast pace is responsible for this and the remedy can only be found in the quick work of the driver. It calls for the quickest action on the steering wheel; often the quickest is not quick enough. If a front tire goes the exigency calls for a certain operation, and if a rear tire goes another course must be pursued. The majority of racing drivers are entirely familiar with these operations; they know what to do, but sometimes fate is against them. One partial remedy is always to make sure by inspection before each race that the tires are in perfect condition and securely fastened to the rims.

### PREVENT RATHER THAN CURE

MANY automobilists try to progress by driving through reverse gear when it comes to legislation governing the automobile. Every week or so we read of a new law being enacted restricting the speed of a motor car to four or six miles per hour on a corner or at a crossing, and a few weeks later we read of how the automobile owners have banded themselves together to fight the new law in the courts. The automobilists were a little slow. Instead of fighting in the courts they should have started before the laws were finally passed in the Legislature. It is easier to fight a bill in the Legislature than it is to carry it through all of the law courts and even up to the Supreme Court of the land. Prevention is better and cheaper than cure.

The automobile manufacturer and dealer is often too busy with his business of buying and selling cars to think of legislation before it is enacted, and when it is enacted he almost stampedes. One example of this is the recent prohibitive legislation in Detroit, the biggest automobile manufacturing city in the country. An absurd law has been passed; this law is being violated every day by practically every car owner; fines as high as \$200 are being assessed and already thousands of dollars have been collected in fines. The money that has already been spent in fines would, if properly used before legislation was enacted, have resulted in the passage of a sane measure. What is happening in Detroit is happening month after month in a score of other cities. It is a Rip Van Winkle policy until the law is enforced and then a money-wasting one. Every locality should have its legal representative who watches all pending legislation and every effort should be made for rational legislation before it is too late. Banding together to keep an eye on possibly unwise legislation must not be interpreted as being opposed to all legislation. The object is to defeat irrational measures before their enactment, when it can be done at much less expense than after such laws have been passed by the Solons and inscribed on the statute books

\* \* \*

### TELL THE TRUTH

ONE great detriment to the early popularization of the freight automobile is the tendency on the part of salesmen to overstate the benefits that will result from the installation of a motor service in a large commercial or manufacturing establishment. It would seem to be the part of wisdom that the prospective purchaser be told the exact requirements of the situation. He must not be allowed to buy under the delusion that his trucks and delivery wagons may be safely entrusted to the tender mercies of the erstwhile teamster, boy or man, lacking experience and working for wages which are anything but an incentive to the acquisition of the knowledge requisite to a proper performance of his duties. Nor must the purchaser be allowed to go on his way without being warned of the dire results which will follow upon the overloading of his trucks and wagons. A freight automobile system should not be installed without thorough preparation; drivers should be trained and all the details of the system—repairs, relief and service—should be reckoned with before undertaking such a radical change.

# Progress Shown in Elgin Races

## Fast Time Indicates Improvements in Cars

*H. A. Bonnell, General Manager of the Automobile Board of Trade, points out the great lessons to be learned from the recent Elgin National Stock Chassis races, particularly emphasizing the advancement in the art of building automobiles on stock lines and for stock purposes.*

RACES such as those held at Elgin last Friday and Saturday demonstrate the progress in making automobiles about as forcibly as anything could, according to H. A. Bonnell, general manager of the Automobile Board of Trade. Improvement in the course undoubtedly had some effect upon the fast time made this year, but it would hardly account for the tremendous reductions of the record in three of the races. In discussing the matter Mr. Bonnell said:

"That there has been great progress made in the manufacture of automobiles this year is clearly indicated by the splendid showing made by the stock cars that competed over the Elgin course last week. The roads were in better shape than ever before and a number of narrow places had been improved, all of which means that the normal time ought to have been faster than in previous years, but hardly as much as the actual figures show, unless some betterments had been made in the construction of the cars themselves.

"Take the showing of the Lozier entry in the Elgin National race. Last year the Lozier car won a splendid race rather easily in 29:29:84, or an average of 62.5 miles an hour. This year, with substantially the same type of car, which of course carried the improvements and refinements of the current model, the speed made by it was 69.78 miles per hour for eight laps. A difference of over 7 miles an hour in the rate of speed accomplished could hardly have been credited in its entirety to the difference in the condition of the course. The car itself must have been faster.

"The mishaps that befell several of the contestants in the big race at various stages of the event might all be laid to increased vibration caused by minute bumps in the roadway, which would argue that much more emphasis should be laid upon the quality of the cars themselves. These mishaps included burned-out bearings, broken gasoline line and the fracture of parts that were particularly subjected to the intense vibration, all of which are accidents likely to occur from the combination of great speed with uneven roads.

"National 2, driven by Zengel, which won the race, made the thirty-six circuits almost seventeen minutes faster than the winning time of the Lozier in 1910 and averaged better than 66 miles an hour throughout. From any angle this performance is excellent as it means the sustained speed of the fastest railroad train carried over a distance that would discourage the best equipped railroad in the world. Twice the winner paused for fuel and then went on without a skip to a fine victory. It means that if there was a protected, straightaway speedway from New York to Chicago a business man might make the distance in five or six hours less than the great railway trains, if he happened to be in a big hurry.

"Of course the difficulties that were met in the Elgin roads really served a purpose in detecting weaknesses and while the mishaps that caused the withdrawal of several of the cars were trifling in themselves they were sufficient to insure defeat despite the fact that they could have been repaired with but small delay. When the leading group in a long race, such as the Elgin, is making better than 66 miles an hour and going along without

a miss it is little use to take a handicap of fifteen minutes of half an hour by making repairs and then run the chance of again breaking down in the tremendous spurt that would be necessary to bring a car back into contention for the lead.

"The inexorable rule of mechanics that wear on tires and mechanism is in proportion to the square of the velocity, while the speed is represented only by the velocity itself, is one of those things that cannot be avoided in making up time and the right thing to do under the circumstances is to withdraw. Take for example the experience with Alco 7 (Hartman). According to the reports, this car suffered a break in its gasoline line while going nicely in the last half of the race. Such an accident is not sufficient to retire a car from competition, but to repair it would require probably 15 minutes. The car was not right up among the leaders when the mishap occurred and if it had continued it would have been heavily handicapped. If Hartman had tried to make up the lost ground by opening wide his throttle the chances of accident would have been emphasized.

"The running of the Illinois Cup race proved to be a rather hollow victory for the National also, but the fact should not be lost sight of that all four cars entered in this event were running smartly at the end and that all would have finished in good time if they had been allowed to proceed. The winner beat the time of last year's winner by 15 minutes. In the Kane County race for 231-300 cars the most astonishing showing was made. Seven cars out of the eleven that started completed the full distance and the winner lowered the record of last year in this race over 27 minutes.

"The cars that ran in the Kane County Cup race are automobiles such as the average owner drives and such as one may see on the streets and boulevards at any time. Those in the Aurora Cup race are lighter cars than the contestants in the Kane County race, while the entries in the Illinois were big cars with power enough to keep them away from the dust of almost anything they are likely to meet on the road. In the Elgin National the contestants were not limited as to piston displacement save that they were obliged to be under 600 cubic inches. This let in the highest powered cars manufactured in the United States in stock models.

"Now the best of such races as those run at Elgin is the fact that they are supervised by technical experts to the end that the public may be assured that the cars that perform in competition are identical with the cars of the same model sold over the counters of the various automobile salesrooms. The average buyer does not wish to enter track or road competition, but he does want to know that simple pressure on the accelerator will develop high power and great speed.

"The idea of such races as those at Elgin is to afford an object lesson to the public. The whole effort is made to show automobile owners and prospective buyers the quality of the contestants. In special races there are two objects, first to afford the public a spectacle and second to show manufacturers the merits and demerits of their special productions. The recent Indianapolis race is within this latter category, while the Elgin races come directly within the former.

# Detroit in the News of the Week

## Cadillac Cars to Have Electric Self-Starter

*Studebaker Corporation invites 1800 dealers to visit its plants—Automobile industry has almost doubled Michigan's investment in manufacturing within five years—General Motors stock now formally listed in the big exchanges—Chalmers predicts record year for industry and points out advantages of export trade and danger of over-production—Packard truck completes transcontinental run in forty-seven days from start to finish.*

**D**ETROIT, Aug. 28—Formal announcement of the 1912 Cadillac, awaited with interest by the entire trade for some time, has been made at last, and reports of radical innovations, current for some time as matters of gossip, were confirmed in part. According to the announcement, the new Cadillacs will be equipped with an electric device capable of automatically starting the motor, furnishing current for all the lights, and supplying ignition for the motor. The device is of the storage battery principle, a dynamo generating electricity being attached to the motor.

The starting device is operated by retarding the spark lever and pushing gently down on the clutch. It is said that the battery when charged, is capable of turning the motor for 20 minutes. When the motor starts its explosions, the electric device stores up current until full charged, when it automatically cuts off from the motor. As an ignition device, the Cadillac's equipment will furnish a spark at slow speeds from the storage battery. At 300 r.p.m. the apparatus shifts automatically and furnishes the spark through the high-tension system.

Other changes announced for the 1912 Cadillac are 36-inch wheels, new carbureter, larger brake drums, steel bodies, and increased gasoline capacity. All the 1912 models will be of the enclosed front type.

The E-M-F Company plants of the Studebaker Corporation start this week a series of systematic gatherings of dealers which will be on a larger scale than anything in the history of the industry. The company has invited every one of its 1,800 retailers to visit the factory for two days, making the trip at the company's expense and being its guests while in the city. The visits will be made under the auspices of the various branch managers, dealers tributary to the branches at Atlanta, Ga., and Birmingham, Ala., being selected to open the series.

It is the aim of the Studebaker Corporation to become thoroughly acquainted with its dealers and to familiarize the dealers with the manufacturing processes by this method. The visit of the dealers and the arrangements for entertainment are in the hands of Paul Smith, former assistant general sales manager, who has been appointed sales manager.

The motor car industry is given large credit for the enormous increase which U. S. census statistics show for Michigan, during the past five years. During that period, Michigan's investment in manufacturing increased from \$337,894,000 to \$583,947,000; salaries and wages paid from \$98,749,000 to \$153,838,000; and the value of the products less cost of material, from \$190,039,000 to \$316,497,000.

While the most remarkable strides have been made by Detroit, Flint, Pontiac and Lansing, the state in general has become a hive of automobile activity. In fact, the largest increase in number of plants this year has been chronicled outside the centers mentioned. One of the new factories is that of the Gaylord Motor Car Co. of Gaylord. This city is located well up in the northern part of the lower peninsula. The Gaylord Co. already has experimental models undergoing tests. A. B.

C. Comstock, a wealthy lumberman, is president; John A. Hixon, vice-president; John J. Munger, secretary and J. Lee Morford, treasurer.

Another new Michigan concern is the Michigan Adjustable Hub Co., of Bay City, which has started the manufacture of a boltless, adjustable wheel, said to be capable of withstanding a load of 43,000 pounds. The company is investing heavily in machinery and its product will be a simple job to assemble, when the automatic machinery has done its work.

A local change of note is the increase of the capital of the Automobile Manufacturing & Engineering Co., of Detroit, from \$1,000 to \$50,000.

It is announced from the local headquarters of the General Motors Co., that the New York Stock Exchange had granted an application for the listing of the company's stock. Similar arrangements are being made in Boston. The first transaction on the New York exchange, in the stock was the sale of 100 shares at 51 1-2.

The new plant of the Continental Motor Co. is about ready for the installation of machinery. It has been definitely decided that the Detroit factory will be made its general headquarters and the officers, who have formerly been attached to the plant at Muskegon, are now removing their families to Detroit.

The Abbott Motor Car Co. has established a Detroit branch in the new Dodge Building, placing E. C. Thompson of the factory sales organization in charge. A service department will be attached.

The Regal Co. announces that, some time in the near future, one of the firm's underslung "Twenties" will leave Detroit to establish a speed record between this city and Chicago, and return. It is planned to make the affair a non-stop run, as well as a speed demonstration. The car will be driven by L. J. Wilcox, race driver, and will carry C. B. Sims of the Regal advertising department. A trial trip was recently made to acquaint the driver with the road and the conditions which will be encountered.

The Wolverine Automobile Club is prosecuting an energetic campaign of road posting. The club's committee, in an Everitt "30" loaned by the Metzger Co. for the purpose, has already posted both the main routes between Detroit and Toledo and is now at work on the main-traveled route between Detroit and Port Huron. The work will be prosecuted through the season, the next routes to be posted being Detroit to Saginaw, and Detroit to Chicago, the last-mentioned highway being by way of Battle Creek and Kalamazoo. Signs of 1-inch lumber are used, black background and a large white arrow pointing the main highway. The name of the city toward which the route runs, is tacked to each sign in copper letters. Through the courtesy of the Michigan Bell and Home Telephone companies, the Wolverine Club's committee has been able to make use of telephone poles for nearly all its signs. This has greatly facilitated the work of posting.

In a recent address on "The Future of the Automobile Trade"

President Hugh Chalmers of the Chalmers Motor Co. stated it as his belief that 1912 would be a most prosperous year for the industry. He saw but one danger—that of over-production, and urged fellow manufacturers to make careful estimates of the demand before forming their plans for the year. Mr. Chalmers called especial attention to the export trade and believes that the demand for medium-priced American-made cars from abroad will continue to increase. In his belief the future of the industry lies largely in thoroughly standardized cars of this type.

The Packard Motor Car Co. received news several days ago of the successful completion of a transcontinental trip by one of its 3-ton trucks. The start from New York was made July 8 and the finish at San Francisco took place Thursday, August 24. The trip was uneventful until the territory west of Omaha was reached, after which encounters with weak bridges, deep fords, mountains and deserts made it one of great difficulty. E. L. Burnett, of Detroit, drove the car. With him were W. T. Fishleigh and Arnold Hainer.

The Warren Motor Car Co. announces the establishment of a London agency with the firm of McCurdy & Co. A representative is also arranging for a retail dealer in Paris.

### Crude Rubber Holds at Lower Level

AKRON, O., Aug. 28—Crude rubber prices remain lower than they have been for several years, and indications are for modifications in tire prices for the new season. A steady decline in crude rubber quotations has been noticed for nearly three years, ranging from a high point of \$3.00 a pound, to "dollar rubber," which was the rate recently. The present rate of about \$1.20 is considered by local manufacturers to be likely to continue, and they declare that in all probability there can be no return to the former high prices of the crude product.

The high rubber price is credited by local manufacturers directly to London and Brazilian attempts to corner the crude rubber market. When Brazilian jobbers and producers combined to raise prices by withholding rubber from the market, and at the same time borrowed money from the Brazilian government on what they stored, American manufacturers bought as little as possible, and fought the combine as hard as they could, even at the expense of their own ability to turn out orders, and the corner finally broke. The slump has been steadily continued ever since.

### Baltimore Dickering for Last Toll Road

BALTIMORE, MD., Aug. 28—A meeting of citizens of Baltimore was held in Mayor Preston's office to determine upon a price, if possible, for the purchase of the tollgate on the Reisterstown Turnpike, near the Park Heights avenue entrance of Druid Hill Park, the only tollroad remaining within the city limits. At the conclusion of the discussion Mayor Preston asked the directors of the turnpike company if they would accept \$70,000. They said that they would recommend the acceptance of \$75,000, \$5,000 less than they asked the Good Roads Commission and \$15,000 more than the Commission offered.

Before saying the city would consent the Mayor persuaded the directors to let the city examine the company's books. This will be done by experts. In the event of a disagreement between the city and company abutting property-owners present offered to donate enough land to build a road parallel to the toll road so that the city would have an outlet in that section without using the toll road.

### Quaker Trade Meet Postponed a Week

PHILADELPHIA, Aug. 28—Originally scheduled to take place on Saturday, September 16, the date for the race meet to be conducted by the Philadelphia Automobile Trade Association has been set forward a week and will be held at the Point Breeze

track on Saturday, September 23, two weeks previous to the Fairmount Park Road Race.

By postponing the event a week not only will the meet attract a greater number of fast cars but also a larger list of the best drivers, for the originally-selected date conflicted with the meet to be held at Syracuse, N. Y., many noted machines and drivers being entered in that event. The Trade Association's original application to the American Automobile Association for sanction to hold races on September 16 had been granted, and to-day the necessary permit for a change of dates was received by Secretary J. H. Beck.

### Lu Lu Temple Club Will Run

PHILADELPHIA, Aug. 28.—On Saturday, September 16, the recently organized Lu Lu Temple Automobile Club will conduct its initial social run, the objective point being Atlantic City. In addition to souvenirs to be presented each car entered before the Saturday preceding the run, special trophies will be awarded cars finishing nearest to the secret time schedules, the latter to be determined by the usual method—two secret guesses to be made, sealed until completion of the event, opened and the two times added together and divided by two, the result being the allotted time, the winners to be the cars finishing nearest to it. While in Atlantic City cars will be parked on Young's Pier. A large and representative list of entries has already been received, insuring a successful affair.

### Anderson Memorial Road to Be of Service

BRETTON WOODS, N. H., Aug. 28—Within less than a month there has been subscribed to the John Anderson memorial road which is to be built in New Hampshire just \$16,500. The Bretton Woods Company subscribed \$5,000 and the remainder was added by motorists who knew the late Mr. Anderson personally. Under the plans now worked out the boulevard will be about 25 miles long and connect Crawford and Franconia notches. There were six grade crossings on the first plan, but a new route has been selected so that there now will be but one railroad crossing in the entire route. State Engineer Hill has gone over the route and all the officials connected with his department are enthusiastic over the road.

### Fine Cup for Winner at Columbus

COLUMBUS, O., Aug. 28—Arrangements for the 200-mile automobile race to be held September 3 under the auspices of the Columbus Automobile Club, are rapidly maturing. The Hotel Hartman will give a handsome cup to the winner of the contest. The cup is 20 inches in height, bears two winged wheels and is a model of beauty. The club has contracted for three tons of calcium chloride to keep down the dust on the track. Entries for the event are coming in rapidly and it is believed there will be more than a dozen starters.

### Transoceanic Balloon Finished

AKRON, O.—The gas bag for the balloon with which Melvin Vaniman will try to fly across the Atlantic in October, has been completed at the factory of the Goodyear Tire & Rubber Co. and will be shipped next week.

The gas bag alone weighs two tons and a special flat car is used for its shipment, in a box 30 feet long by 6 feet wide.

### Gimbel Buys Score of Trucks

CLEVELAND, O., Aug. 28—The White Co. of Cleveland, Ohio, announces the sale of twenty of their 1,500-pound motor delivery wagons to Gimbel Bros. of New York City. Also the sale of five of these cars to The Hub clothing store of Chicago—these five cars will entirely displace the horse equipment now in use.

## Records Fall at Elgin Stock Races

(Continued from page 340.)

which in turn had a lead of 9 seconds over the Wishart Simplex. Grant was in fourth place, 14 seconds behind Wishart, with Mercer, the Hartman Alco, the Lee Alco and the Pope-Hartford following in the order named. In the fourth lap the Wishart Simplex moved into second place, 58 seconds behind the flying Mulford, Zengel dropping back to third place and Grant retaining fourth, the other quartet retaining their respective positions. The fifth circuit saw the Wishart Simplex, which had been making a strong bid, bowled out, the trouble being a burnt-out connecting rod bearing. As a result of the Simplex's withdrawal, Zengel once more swung into second place, 1 minute 18 seconds behind Mulford, who was still continuing his record-breaking performance, as laps in 7:14, 7:19 and 7:18 will indicate. Grant in Alco No. 1 moved up in third place, 20 seconds behind Zengel, with Hughes in the Mercer following 40 seconds behind and the Hartman Alco 13 seconds behind Hughes. The sixth, seventh and eighth rounds brought no change in the relative positions of the seven remaining contenders, although at the conclusion of the latter circuit Mulford had so consistently added to his advantage that he was now but 2 seconds short of being a full 2 minutes ahead of his nearest rival, Zengel in National No. 2. The latter was 61 seconds ahead of the Grant Alco, which in turn had almost 4 minutes' advantage over the Mercer. The Hartman Alco was about 1 1-2 minutes behind the Mercer with the Lee Alco and the Pope-Hartford far behind, and, barring accidents to the leaders, out of the race.

The Lozier's remarkable work in the first 8 rounds exemplify the old adage that the race is not always to the swift, for the big white car limped into the hospital just short of its ninth round and the announcement was megaphoned that the car was permanently out of the race with a broken connecting rod. This put the Zengel National into the lead by a margin of 1 minute 16 seconds over the Grant Alco and the huge crowd of spectators, deprived of the hope of a second win for Mulford, settled back comfortably in the belief that there would be furnished a heart-breaking contest between the two leaders. At this point the Mercer was trailing along in third place, but 42 seconds behind the Grant Alco, followed in turn by the Hartman Alco, which was 23 seconds in the rear and by the Lee Alco and the Pope-Hartford, the latter being over one-half hour behind. From the tenth to the sixteenth laps there was little to vary the monotony of the grind with the exception that Alco No. 7, which had been trailing along in fourth place, moved up to third in the twelfth round and maintained its position during four circuits. The sixteenth round saw the Mercer, which had been held up at the pits on two occasions for refilling and tire changes, regain third place, but it was nearly 4 minutes

behind the Grant Alco, which was second, a trifle over 2 minutes behind the leader. The seventeenth, eighteenth, nineteenth and twentieth round saw no change in the relative positions of the six contenders, the conclusion of the last-named circuit showing Zengel to be 2 minutes 12 seconds ahead of the Grant Alco, with the Mercer in third place over 4 minutes behind, and the Hartman Alco a bad fourth, the latter having been delayed by a leak in the gasoline line, which compelled its withdrawal in the next round. The Lee Alco was plugging along in fifth place and Buck in the Pope-Hartford was plodding along doggedly many miles behind.

On the twenty-first lap the Zengel National made its first stop, having gone over 177 miles without a let up. The stop, however, was a short one and after filling with gasoline, Zengel was away amid the cheers of the huge crowd, but with a loss of a full minute to the fast flying Grant, the margin now separating the two cars being but 1 minute 21 seconds. The Mercer was, at this point, over 4 minutes behind the Grant Alco but still in third place. The crowd began to hope for the National-Alco duel which the enforced withdrawal of Mulford's Lozier



The Lozier was the last to start in the Elgin Cup race, but was soon breaking the record on every lap

had seemed to portend. The twenty-second lap, however, saw Grant lose all the advantage he had gained by Zengel's stop, with another minute added to the handicap that he would be compelled to overcome in order to catch the leader. Grant stopped for gasoline and water, the filling of the latter being rendered somewhat slow owing to the high pressure in the radiator, the force of the steam blowing the water aside and preventing rapid filling. This was really the deciding point in the race for first place, for barring the possibility of stops on account of tire trouble Zengel's lead was sufficient to enable him to play it safe to the end of the race, although, as it happened, he consistently out-drove Grant, in all but the very last lap, when, with the prize practically in his grasp, he negotiated one of the slowest laps of the entire thirty-six, barring, of course, those in which he was compelled to stop for supplies. These were in the twenty-first lap, as above mentioned, and again in the thirty-second lap, on both of which occasions the crew at the pit performed their work in jig time. Grant's second stop—for gasoline and water—also in the thirty-second round, gave a comparison of the working of the two pit crews, the National outfit showing a sprightliness that cast the efforts of the Alco contingent into the shade, although the fact that the Alco had to take on water in addition to the gasoline was what really caused the delay.

The first position settled, barring accidents, the race for second place between the Grant Alco and Mercer No. 9 now attracted the attention of the spectators. When Grant made his long stop in the thirty-second round Hughes saw his opportunity and at the close of that lap he had almost closed up the gap which separated his car from second place, Grant's margin of lead being but 24 seconds. This was still further reduced in the thirty-third round to 16 seconds, increased to 17 seconds in the



The "men behind the score-board" saw little of the races



thirty-fourth lap and reduced to 12 seconds at the conclusion of the thirty-fifth circuit, the next to the last of the race. The sympathies of the crowd seemed to be with Hughes in the Mercer, his brilliant victory of the preceding day having made him a general favorite. The Alco, with its excess of power, was enabled, however, to hold the Mercer safe and although the latter covered the last lap a second faster than its rival, it was unable to close up the gap, a matter of but about 11 seconds separating the two cars at the finish. Alco No. 5, which had met with a variety of troubles throughout the race, was still running at its conclusion, having covered thirty-two of the thirty-six laps—about 272 miles.

### What Happened at the Pits

An hour before starting time on the first day of the Elgin National Stock Chassis Races, the racing cars entered in the Illinois, Kane County and Aurora cup events began to line up opposite their respective pits, where they immediately were seized upon by the technical committee for the final examination.



Alco, No. 5, which finished fourth in the big race, and was still running at its close

This examination was not a fruitless one, for several of the cars appeared for the start with ignition wires and gasoline pipes taped in a very much more substantial manner than was customary in the regular stock chassis construction. All of these extra precautions counted for naught, for this tape had to be removed, much to the chagrin of the drivers and mechanics.

Herein lies one of the many benefits to be obtained from stock car racing. The weaknesses will out, and the maker, if he be a conscientious one, will profit by his experience and strengthen not only his racing cars but those which he sells to the public as well.

At 10:40 a. m. nineteen out of the twenty-three cars entered in the three events, were lined up near the tape in the order of their start. The three Falcars entered had not even shown up for practice and the Cino No. 26 had been disabled in practice the day before.

Promptly at 11 o'clock, the first car was sent off by Starter Wagner. This was the National No. 1, with Donald Herr at the wheel. The rest of the cars entered in the 203-mile Illinois Cup and 169-mile Kane County events followed at intervals of 15 seconds; and 15 minutes later the cars entered in the 135-mile Aurora Cup contest followed.

The last car hardly had left the tape when the first halt was made at the pits. Robillard in a Staver stopping for a tire. Half a minute later Jeffkins in a Velie also stopped for a minute at his pit for a tire and water; and four minutes after he had gotten away Gaston Morris (Cole No. 21) drew up to the pit for a tire. It was evident that these drivers were pushing their mounts to the limit, as each of the trio required a new tire at the end of the first lap.

At the end of his second lap Rainey, who was driving Burt's

Cino car, stopped at the Cino pit to exchange an injured tire, which had been replaced on the road, for a fresh one. The Velie driven by Stickney was the first to suffer mechanical trouble, at the end of the third lap a stop of 12 minutes was made during which time Stickney replaced a couple of pushrods that had become stuck in their guides; while the mechanic worked on the hand oil pump, which had broken. While these repairs were being made, Armstrong in his Colby stopped for 4 minutes to replace a reinforcement bolt that had been lost from the engine gearcase. The sleeve that is used inside of the case had dropped down into the case and was rattling around harmlessly, but considerable oil was being lost through the bolt holes. For the want of an extra bolt, the holes were plugged with wood and the car again sent on its way. As Armstrong drew away from his pit, Ogren in another Colby coasted past and brought his car to a stop about 100 yards beyond the repair pits, where it was left throughout the race. There had been a leak in the oil supply and the pistons had seized in the cylinders for the want of sufficient lubricant.

The Staver, driven by Monckmeier, was brought to a halt at the pits at the end of the fifth lap, so that the auxiliary oil tank which had been broken could be removed, and water taken on. For the want of oil, the motor had become so hot that when the radiator cap was loosened it shot up into the air, and water and steam spouted from the radiator. In four minutes, however, the little car again went on its way.

Armstrong's Colby was again brought to a stop at the pits at the end of the seventh lap. At this time 9 minutes were lost. The nut from the right rear spring shackle had been lost, and was being replaced by the driver, while the mechanic was sent down the course to take a bolt from the engine gearcase of Ogren's disabled car. Having replaced the lost engine bolt and fitted a new bolt in the spring shackle the car was again ready except for the want of oil to replace that which had been lost through the bolt holes in the engine gearcase. It happened that the pit attendants had neglected to put in an extra supply of oil and after several minutes' delay the car started off without it.

Jeffkins' Velie stopped at the pits for the second and last time on its eleventh lap, to take on oil and adjust the carbureter. Two minutes were required to do the work. Fifteen minutes later Stickney stopped for 9 minutes to replace a couple more valve tappets, and take on water and gasoline.

After making six more laps on a diminished supply of oil in the motor, Armstrong brought his Colby to a stop in front of the pit. A supply of oil had been obtained, but when an effort was made to pour it into the tank the tires were in the way and no funnel was at hand, the result was that half the oil was poured on the ground and the tires, and half into the tank. The motor was so stiff from running so long without sufficient lubricant that the mechanic could not crank it; but a husky pit attendant managed to do this and car was again in the race after a delay of four minutes. That the Colby company is new in the racing game was very apparent; too much



The press stand and score-board facilities were complete in every respect



National No. 1, winner of the Illinois Cup, rounding Hoornbeck's Corner

was left to Pearce, the driver of the third Colby entry, who had his hands full during the race in bringing his car into third place at the finish. A much better showing might have been made by the other Colby entries had it not been for the inefficiency of the repair pit management and equipment.

The last stop made at the pits was made by Robbins' Abbott-Detroit, and was due to a lost magneto coupling.

**The Pits on the Second Day**

With one or two exceptions, there was considerable more snap to the work of the pit attendants during the big race pulled off on the second day. Johnny Aitken's National was the first of the big cars entered in the Elgin Cup event to stop at the pits, and this was at the end of the first lap. The auxiliary air-valve spring of the carbureter seemed to be at fault, for it was replaced by a new one, while Johnny fussed around the pit, threatening to quit at once. In three minutes, however, the carbureter was repaired and away he went.

The next stop was made by Buck in a Pope-Hartford to take on a fresh tire in place of one which had been replaced on the road. Less than a minute was required to make the change.

This was just the start of considerable tire trouble for Buck, which eventually caused the death of both Buck and Jacobs, his mechanic.

After making two laps in excellent time Ralph DePalma's Simplex was silently brought to a stop at the side of the road at the approaching end of the pits. The engine had been stopped some distance up the road and the car had simply coasted down to the grandstand where it was left by the roadside. The flywheel had broken. At the end of the fourth lap Buck again brought his Pope-Hartford to a halt at the pits for another tire and to remove the speedometer shaft which was broken off when the tire of the right front wheel came off. A few minutes later Johnny Aitken's National rolled up to the pits, then backed off onto the side of the road behind DePalma's disabled Simplex; the rear cylinder was cracked.

Buck stopped again on the seventh lap to take on another tire.



The Mercer (Hughes) burning up the backstretch at a 65-mile clip

and five minutes later Ralph Mulford's Lozier rolled down on the side of the road behind Aitken's National. A connecting rod bearing of the front cylinder had been burnt out, the rod had been broken and had pushed a great hole in the crankcase, the

**TABLE SHOWING POSITION OF THE CARS AT THE CONCLUSION OF EACH LAP DURING THE FOUR ELGIN RACES**

		AURORA TROPHY.																			
No.	Car.	Lap 1	2	3	4	5	6	7	8	9	10	11	12	13	14	15	16	17	18	19	20
31	Abbott-Detroit	1	1	2	1	1	1	1	1	1	1	1	1	1	1	1	1	1	1	1	1
32	Ford	3	3	3	2	2	2	2	2	2	2	2	2	2	2	2	2	2	2	2	2
33	Abbott-Detroit	2	2	1	3	3	3	3	3	3	3	3	3	3	3	3	3	3	3	3	3

		ILLINOIS TROPHY.																							
No.	Car.	Lap 1	2	3	4	5	6	7	8	9	10	11	12	13	14	15	16	17	18	19	20	21	22	23	24
1	National	2	1	1	2	2	2	2	2	1	1	1	1	1	1	1	1	1	1	1	1	1	1	1	1
3	National	1	2	2	1	1	1	1	1	2	2	2	2	2	2	2	2	2	2	2	2	2	2	2	2
2	Vellie	4	4	4	3	3	3	3	3	3	3	3	3	3	3	3	3	3	3	3	3	3	3	3	3
4	Vellie	3	3	3	4	4	4	4	4	4	4	4	4	4	4	4	4	4	4	4	4	4	4	4	4

		KANE COUNTY TROPHY.																			
No.	Car.	Lap 1	2	3	4	5	6	7	8	9	10	11	12	13	14	15	16	17	18	19	20
15	Mercer	1	1	1	1	1	1	1	1	1	1	1	1	1	1	1	1	1	1	1	1
12	Mercer	5	2	2	2	2	2	2	2	2	2	2	2	2	2	2	2	2	2	2	2
20	Colby	7	5	5	5	5	4	4	4	4	4	4	4	4	4	4	4	4	4	4	4
24	Cole	2	6	6	6	6	5	5	5	5	4	4	4	4	4	4	4	4	4	4	4
14	Corbin	3	3	3	3	3	3	3	3	3	3	3	3	3	3	3	3	3	3	3	3
21	Cole	8	8	7	7	7	6	6	6	6	6	5	5	5	5	5	5	5	5	5	5
27	Staver-Chicago	6	4	4	4	4	8	7	7	7	7	6	6	6	6	6	6	6	6	6	6
22	Colby	9	9	11	11	11	10	8	8	8	8	8	8	8	8	8	8	8	8	8	8
11	Cino	4	7	8	8	8	8	7	7	7	7	7	7	7	7	7	7	7	7	7	7
25	Staver-Chicago	10	10	9	9	9	9	9	9	9	9	9	9	9	9	9	9	9	9	9	9
18	Colby	11	11	10	10	10	10	10	10	10	10	10	10	10	10	10	10	10	10	10	10

		ELGIN TROPHY.																																			
No.	Car.	Lap 1	2	3	4	5	6	7	8	9	10	11	12	13	14	15	16	17	18	19	20	21	22	23	24	25	26	27	28	29	30	31	32	33	34	35	36
2	National	3	2	2	4	2	2	2	2	2	1	1	1	1	1	1	1	1	1	1	1	1	1	1	1	1	1	1	1	1	1	1	1	1	1	1	
1	Alco	5	5	4	3	3	3	3	3	3	2	2	2	2	2	2	2	2	2	2	2	2	2	2	2	2	2	2	2	2	2	2	2	2	2	2	2
9	Mercer	7	7	5	5	4	4	4	4	4	3	3	3	3	3	3	3	3	3	3	3	3	3	3	3	3	3	3	3	3	3	3	3	3	3	3	3
5	Alco	8	8	7	7	6	6	6	6	5	5	5	5	5	5	5	5	5	5	5	5	5	5	5	5	5	5	5	5	5	5	5	5	5	5	5	5
3	Pope-Hartford	9	10	8	8	7	7	7	7	6	6	6	6	6	6	6	6	6	6	6	6	6	6	6	6	6	6	6	6	6	6	6	6	6	6	6	6
7	Alco	6	6	6	6	5	5	5	5	4	4	4	4	4	4	4	4	4	4	4	4	4	4	4	4	4	4	4	4	4	4	4	4	4	4	4	4
12	Lozier	1	1	1	1	1	1	1	1	1	1	1	1	1	1	1	1	1	1	1	1	1	1	1	1	1	1	1	1	1	1	1	1	1	1	1	
4	Simplex	2	3	3	2	1	1	1	1	1	1	1	1	1	1	1	1	1	1	1	1	1	1	1	1	1	1	1	1	1	1	1	1	1	1	1	
11	Simplex	4	4	4	4	4	4	4	4	4	4	4	4	4	4	4	4	4	4	4	4	4	4	4	4	4	4	4	4	4	4	4	4	4	4	4	4
6	National	10	9	9	9	9	9	9	9	9	9	9	9	9	9	9	9	9	9	9	9	9	9	9	9	9	9	9	9	9	9	9	9	9	9	9	9

oil had been lost, and the motor was running spasmodically from the overheated condition with the ignition cut out. The great race was hardly started, and three of the most prominent cars were out of it.

After succeeding in making four laps without stopping at the pits for tires, Buck came up to the grandstand at the end of the eighth with the right rear tire dangling from the axle. Three minutes elapsed before the old tire was removed and a new one replaced. By this time the Pope-Hartford pit had used up all of its extra tubes, and the team manager was kept busy borrowing tubes from officials and others having spare tubes in their cars of the required size.

Frank Lee's Alco made its first stop at the pits on the eleventh lap; two right rear and one left rear tires had been replaced on the road and the stop was made to take on a fresh supply. There also was some trouble with the hand oil pump so the piston was removed and the cylinder plugged with a cork. After replenishing the water supply in the radiator, the car was again put under way; three minutes' time having been lost. Harry Hartman's Alco made its first stop at the pits at the end of the fourteenth lap, and two rear tires were changed and water administered to both the crew and the car.

Buck, who was finishing his twelfth lap, made the next stop to take on a tire. A few minutes later Hartman again drove up with his Alco to take on oil and gasoline, change a left rear tire, and replace a spark plug lead that had become disconnected. This caused a delay of four minutes.

There was considerable excitement in many of the pits when Len Zengel in the winning National drove up to the pits for the first time at the end of his twenty-first lap. He did not tarry long, however, for in half a minute he was again on his way. At no time could it be said that the pit attendants of the National outfit were lacking in agility, but on this occasion they certainly exhibited some speed.

Frank Lee's Alco drew up to the pits on its eighteenth lap for



Line-up at the start of the Illinois Cup race on the first day

oil, water and gasoline, and to replace the left rear tire; and during the four minutes consumed Harry Grant also brought his car to a stop for the first time during the race. The stop lasted for but a minute and a half, during which time gasoline and water were taken on. Even this, however, was rather poor service on the part of the pit attendants, for it took the National but one-half minute to take on gasoline, water, and oil as well. At the end of his sixteenth lap Buck made another stop for oil, gasoline and tires.

Hughie Hughes, whose little Mercer had been running like a watch, stopped at the pit for the first time at the end of the twenty-first lap for gasoline, oil and water. Lee's Alco stopped for one minute on the twenty-fourth lap to replace the left rear tire.

At the end of the thirty-second lap Len Zengle brought considerable joy to the hearts of those in the Alco pit by bringing his car to a stop at the National pit for the second time. Their

joy was short-lived, however, for in less than forty seconds he was off again with a fresh supply of gasoline, and five minutes later Grant called a halt of one minute to change right rear and left front tires.

Equipment of the Racers

The following table, showing the equipment of the various contesting cars as regards carbureters, magnetos, tires, etc., will be found interesting:

ELGIN NATIONAL TROPHY					
No.	Car	Carbureter	Magneto	Ignition System	Tires
1	Alco	Gray	Bosch	Single	Michelin
2	National	Schebler	Splitdorf	Double Dis.	Michelin
3	Pope-Hartford	Pope-Hartford	Bosch		Racine
4	Simplex	Simplex	Bosch	Double Dis.	Michelin
5	Alco	Newcomh	Bosch	Double Dis.	Michelin
6	National	Schebler	Splitdorf	Double Dis.	Michelin
7	Alco	Newcomh	Bosch	Double Dis.	Michelin
9	Mercer	Schebler	Bosch	Double Dis.	Michelin
11	Simplex	Simplex	Bosch	Double Dis.	Michelin
12	Lozier	Rayfield	Bosch	Double Dis.	Michelin

KANE COUNTY TROPHY					
No.	Car	Carbureter	Magneto	Ignition System	Tires
11	Cino	Stromberg	Remy	Double Dis.	Michelin
12	Mercer	Schebler	Bosch	Double Dis.	Michelin
14	Corbin	Miller	Bosch		Michelin
15	Mercer	Schebler	Bosch	Double Dis.	Michelin
18	Colby	Rayfield	Remy	Double Dis.	Michelin
20	Colby	Rayfield	Remy	Double Dis.	Michelin
21	Cole	Schebler	Bosch		Michelin
22	Colby	Rayfield	Remy	Double Dis.	Michelin
24	Cole	Schebler	Bosch	Dual	Michelin
25	Staver-Chicago	Rayfield	Remy	Double Dis.	Michelin
27	Staver-Chicago	Rayfield	Remy	Double Dis.	Michelin

ILLINOIS TROPHY					
No.	Car	Carbureter	Magneto	Ignition System	Tires
1	National	Schebler	Splitdorf	Double Dis.	Michelin
2	Velie	Rayfield	Remy	Dual	Michelin
3	National	Schebler	Splitdorf	Double Dis.	Michelin
4	Velie	Rayfield	Remy	Dual	Michelin

AURORA TROPHY					
No.	Car	Carbureter	Magneto	Ignition System	Tires
31	Abbott-Detroit	Mayer	Bosch	Single	Michelin
32	Ford	Kingston	Ford	Single	Michelin
33	Abbott-Detroit	Mayer	Bosch	Single	Michelin

Worcester Dealers Ready for Show

WORCESTER, MASS., Aug. 28.—The second annual summer automobile show of the Worcester Licensed Dealers' Association will be held September 4, 5, 6 and 7, under two large tents at the New England fair grounds at Greendale in connection with the big annual agricultural event of this section of the country.

The show, besides embracing many of the leading 1912 models, will have spaces for exhibiting all sorts of accessories and supplies. The cars to be exhibited this year by the members of the Worcester Licensed Dealers' Association, will include Overland, Stanley Steamer, Winton, Cadillac, Maxwell, Rambler, Columbia, Thomas, Everett, Hudson, Elmore, National, Chalmers, E-M-F, Flanders, Mitchell, Stoddard-Dayton, White Gasoline, White Steamer, Velie, Knox, Franklin, Stearns and possibly the Chadwick, Packard, Buick and Regal, along with the following trucks: Gramm, White and Rapid.

The committee in charge of this year's automobile show is Henry J. Murch, chairman; LeRoy Leighton and William Carpenter.



The second line of Illinois Cup contenders, with the Kane County cars in the rear



Pilot Dai H. Lewis in the E-M-F pathfinder as he finished laying out the route for the second annual tour of the Automobile Club of Buffalo

## Thirty in Buffalo Tour

BUFFALO, N. Y., Aug. 28—Present indications are that at least thirty cars will start in the Second Annual Reliability Tour, to be run September 6-9, under the auspices of the Automobile Club of Buffalo, for the Laurens Enos and other trophies.

The pathfinding work for the tour was completed on August 19th, under the direction of Dai H. Lewis. An E-M-F "30" was assigned as the official pathfinder and pilot car for the contest and was driven over the 800-mile course by George Meininger, another skillful driver of Glidden tour fame.

Following the precedent of last year, each day's run of 200 miles will start and finish in Buffalo. The technical end of the event will be in charge of the Contest Board.

The course thoroughly covers western New York from Lake Erie to Lake Ontario, and embodies elements most ideal for a reliability contest. The Laurens Enos trophy was won last year by Charles F. Monroe, Buffalo representative of the United States Motor Company, in a Maxwell. Mr. Monroe has entered four cars in this year's event to defend the cup.

## Two-Day Meet at Brighton Beach

Two days of racing will be served up to the metropolitan public Saturday, Sept. 2, and Labor Day, Sept. 4, at Brighton Beach, under the direction of E. A. Moross. The program shows nine carded events for each day for cars eligible to compete in the "open" classes.

Besides the Moross string there will be several local entries and the sport promised is on a par with that offered at other meets under the auspices of the same promoter. The promised 24-hour race faded away Wednesday when it was announced by the Contest Board that application had been made by Guttenberg promoters for the Sept. 30 date. As this was the date tentatively selected for the long grind, the chances of holding the race are considered very slim.

Previously it had been announced that the promoter of the "twice-around-the-clock" event had secured nine entries and had the choice of two more.

## Good Fields in Fernbank Road Races

CINCINNATI, O., Aug. 28—The Fernbank Dam Road Races to be held Sept. 9 as the culminating feature of the celebration marking the opening of the government dam below this city are attracting country-wide attention. During the Elgin meeting a committee from Cincinnati was busy canvassing the contestants for entries in the quartette of races to be run here.

It was announced that the committee had been successful to a certain degree and that the fields would be fair in each of the races. Southern Ohio is a big manufacturing field and entries from the local factories at Cincinnati and nearby have been promised. The cars will race under Class C limitations.

## Next Week Most Important of Year

Next week will be one of the most important of the year in several particulars as applied to the automobile industry. In a sporting way there will be six race meetings, a road race, hill-climb and an endurance run, which is certainly the high-water mark of the year as far as contest work is concerned. But in a much wider sense, the conferences of the governing bodies of the industry which will be held in New York City are of vastly more import to the trade than the contests.

When the Automobile Board of Trade assembles, the roster of the Madison Square Garden show will be framed. Applications for membership in the organization will be received and acted upon and, after the conclusion of the meeting, the names of those who will exhibit at the show will be known.

The N. A. A. M. also holds one of the most momentous meetings of the season, at which the list of members will be increased and a number of details with regard to both the big National shows will be threshed out. The Manufacturers' Contest Association will meet to act upon the recommendations suggested to its membership at the recent Detroit session of the committee on rules.

The meetings of the A. B. of T. and the N. A. A. M. will be the last at which memberships can be granted this Fall so as to allow participation in the annual shows. The drawings for space will take place shortly afterward and those who wish to show at either of the exhibitions are hustling to get their applications in.

Besides these things the organizations will take up a vast mass of other detail work.

On the meeting of the M. C. A. depends the future of contests and it is quite apparent that there is a division of opinion as to a number of major matters in this class.

## Stock Cars Only in Glidden Tour

The following official correction of the conditions under which the Glidden Tour will be run in October, has been issued by the Contest Board:

"Owing to a misunderstanding of the action of the Manufacturers' Contest Association, taken at the Detroit meeting, August 10 and 11, in reference to the registration of stock cars of private owners in the 1911 Glidden Tour, the supplementary regulations heretofore issued waiving registration requirements are hereby cancelled and registered stock cars only will be eligible to compete for the Glidden trophy and for the cash or plate prizes in the seven price divisions."

The following new entries have been received: J. R. Sandlin, Jasper, Fla., Cadillac; R. D. Drysdale, Jacksonville, Cadillac; Hoke Smith, Atlanta, Maxwell; Studebaker Corporation, three E-M-F's and the McIntyre Company, Auburn, Ind., McIntyre. With these additions the list now contains twenty-six entries.

## Flyers Enter Old Orchard Meet

With the speedy Jackson racer that made such a good showing at Indianapolis Cobe has entered the open events to be decided at the heach meeting scheduled to take place at Old Orchard, Me., Sept. 4, 5 and 6. A Pope-Hartford car handled by Disbrow will also be featured on the sands. Besides these special racers it is expected that some creditable fields will face the starter in the class events. These will probably include a pair of Oaklands, three Camerons, an Atlas, two Buicks and three Velics. There may be some others as well.

## Hartford to Have a Race Meet

HARTFORD, CONN., Aug. 28—The final day of the State Fair will see an automobile race program decided at Charter Oak Park. Ralph De Palma, with a big Simplex, is carded as the free-for-all star and in addition there will be a number of local entries in the class events.

### Ohio Farmers Inspect Models

COLUMBUS, O., Aug. 28—One entire building devoted to the display of automobiles was set aside by the Ohio State Board of Agriculture at the annual Ohio State Fair which is being held this week. It is the first time in the history of the fair that there has been such an extensive display of motor cars and the building was crowded.

The building was reserved for automobiles because of the demands of the farmers of the State that they be permitted to see the latest models of motor cars without leaving the fair grounds. Dealers in Central Ohio as well as factories soon realized the importance of the display and many applications for space were received by the board of agriculture. All of the exhibits were in place by 8 a. m., to-day.

The exhibits were arranged on platforms after the manner of automobile shows. Most of the exhibits are made by the dealers in Central Ohio, although a number of factories sent displays under the charge of their factory men. In all 67 cars were on exhibit which were distributed principally among the medium priced cars. One of the features of the show was the large exhibit of E-M-F cars. The Buick and Mitchell displays also attracted considerable attention. Other makes shown were the Elmore, Jackson, Overland, Zimmerman, Warren-Detroit, Abbott-Detroit, Maxwell, Columbia, Republic, Sampson, Brush, DeTamble, Liberty Brush, Ford, Hupmobile, Speedwell, Empire and others.

### St. Louis to Hold Early Show

ST. LOUIS, Aug. 28—Definite announcement of plans for the open air show to be held Oct. 2 to 7, has been made by the St. Louis Automobile Manufacturers and Dealers' Association. The association believes that in addition to this being the first time an open air show has been attempted on a large scale, it will also mark the first extensive display of 1912 models in this section.

The exhibit is to be held at Forest Park Highlands, an amusement resort, where there is available 60,000 square feet under roof. This is more than twice the space to be had in either the Coliseum or the Armory, where previous exhibits have been held and where there has always been complaint of lack room.

By a system of waterproof curtains all of the space under roof will be arranged so that it can be closed in if there is bad weather. The show will not be open to cars which are not represented in St. Louis by agents, but every St. Louis dealer, whether or not he is a member of the association in charge of the affair, will be taken care of by the committee, according to the announcement.

The show is to include separate displays of motor trucks and delivery wagons and of electric pleasure cars. Plans for decoration now under way provide for carrying out the idea of a forest scene, with tree trunks, bark and autumn leaves used in profusion.

### Boston Figures on Race Meet

BOSTON, MASS., Aug. 28—President E. A. Gilmore of the Bay State A. A. has been in conference with a number of the well-known makers who have racing teams relative to a race meet at Readville this fall. The plans for a meet were first put up to President Gilmore some weeks ago by a prominent promoter, but the Bay State official had his experience a year ago with the Barney Oldfield campaigners, so he was not ready to allow anything else that was not in positive accordance with the contest rules.

Some of the club members thought a race meet would be a good thing and they have been talking it over. One of the members who was going to the Elgin races was asked to talk it over with some of the makers there and see what could be done. The Readville track is recognized as one of the safest in the country and there never has been a fatality there in a

motor race meet... Perfect in Lake Tahoe Run  
caused by a couple Aug. 29.—Six cars out of fifteen finished one of them being an -day in second annual endurance run the track. oe and return. The distance is 520

### Hoosiers Active

SOUTH BEND, Aug. 28—The ordeal were: American 50, vard through the heart of Indiana's sandbanklin 18, runabout, and part of Porter and Lake counties, promises agitation in Laporte county for the improvement , owing to way running east from Laporte through Rolling P. mountain New Carlisle.

With the improvement of the road from Laporte to South Bend the last link in the proposed automobile roadway from South Bend to Chicago would be completed.

### Port Jefferson Climb Sept. 9

Far and away the most important hill-climb scheduled for this season in the vicinity of New York is the event to be held at Port Jefferson, L. I., Saturday, Sept. 9. Last year the climb proved to be both fast and spectacular and drew a big crowd and a typical entry list. This year the fields will probably be smaller in the stock events but in the special numbers the chances are that they will be larger.

Extensive preparations are being made to provide a well-balanced program with full technical supervision and administration.

### Floral Parade in Iowa

DES MOINES, IA., Aug. 28—Des Moines' second annual Iowa State Fair Automobile Show opened Saturday, with the first automobile parade ever held in Des Moines. Fifty cars, decorated from head lamps to tail lights, were entered in the floral pageant and it was one of the most beautiful sights ever seen in the city. Without doubt the floral parade will be made an annual feature. The local dealers were practically all represented in the parade.

A Cartercar driven by Mrs. Howard Schneider, of Newton, Iowa, was given first prize of \$75 for the most beautifully decorated car, while second prize went to the Iowa Automobile Company's Staver car.

The automobile show promises to be one of the big features of the State fair. The space beneath the immense steel grandstand is being used for an exposition hall and 100 cars, representing every dealer in Des Moines, are being shown.

Ray Harroun and the Marmon "Wasp" have been booked as the attractions of the fair and during the week will be pitted in a speed contest against one of the two Wright air men who are at the fair.

Another racer who is here in daily exhibitions is Lou Heine-man and his Case car.

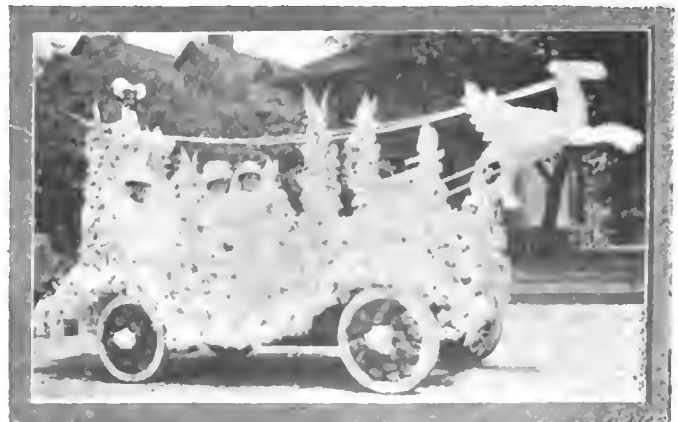

Cartercar driven by Mrs. F. Schneider, of Newton, Iowa, winner of the first prize in the Des Moines floral parade



## Fire Apparatus

line with a policy adopted equipment in the fire department will purchase immediately 250 feet of chemical tank; a ladder truck carrying of ladders; a combination hose and a combination pump and hose apparatus to foot of hose and capable of pumping not less than millions of water a minute.

is now under consideration for this apparatus and contracts will be let after the board has visited the various factories. At this time the fire department is using a squad wagon, a touring car in which the chief answers alarms and a truck for the fire alarm telegraph system.

In bidding for the proposed apparatus, each company was required to submit blue prints and specifications. The bids under consideration are:

Squad wagon: American La France Engine Co., Elmira, N. Y., \$5,500; Knox Automobile Co., Springfield, Mass., \$5,600; Webb Motor Co., St. Louis, \$4,800; Victor Motor Co., Buffalo, N. Y., \$4,185; Harder Truck Co., Chicago, \$3,375; Thomas B. Jeffrey Co., Kenosha, Wis., \$5,250; Meridian Auto Co., Indianapolis (Packard), \$5,277.40; Central Automobile Co., Indianapolis (Grabowsky), \$4,200, and Mais Motor Truck Co., Indianapolis, \$4,750.

Pump and hose: American La France Engine Co., Elmira, N. Y., size 1, \$8,500, size 2, \$7,500; Knox Automobile Co., Springfield, Mass., \$8,100; Robinson Fire Apparatus Co. St. Louis, \$8,000; Webb Motor Co., St. Louis, size 1, \$8,500, size 2 \$7,450; Victor Motor Co., Buffalo, N. Y., \$6,440.

Hose and chemical: American La France Engine Co., Elmira, N. Y., \$5,500; Knox Automobile Co., Springfield, Mass., \$5,600; Robinson Fire Apparatus Co., St. Louis, \$5,500; Webb Motor Co., St. Louis, \$5,000; Seagrave Co., Columbus, O., \$5,000; Pope Hartford Motor Car Co., Hartford, Conn., \$5,000; Victor Motor Co., Buffalo, N. Y., size 1, \$4,665, size 2, \$4,400; Harder Truck Co., Chicago, \$3,375; Thomas B. Jeffrey Co., Kenosha, Wis., \$5,500; Meridian Auto Co., Indianapolis (Packard), \$5,277.40, and Mais Motor Truck Co., Indianapolis, \$4,800.

Ladder truck: American La France Engine Co., Elmira, N. Y., \$5,500; Knox Automobile Co., Springfield, Mass., \$5,200; Robinson Fire Apparatus Co., St. Louis, \$5,800; Webb Motor Co., St. Louis, \$4,500; Seagrave Co., Columbus, O., \$4,900; Victor Motor Co., Buffalo, N. Y., \$4,690; Central Automobile Co. Indianapolis (Grabowsky), \$3,800, and Mais Motor Truck Co., Indianapolis, \$4,800.

## News Notes from Kansas City

KANSAS CITY, Aug. 28—The Mitchell Lewis Motor Co. is to establish a branch in Kansas City, Aug. 31. The building is located at the southwest corner of Sixteenth and Grand streets, right in the heart of the motor row.

E. J. Kilborn, of the Mitchell factory, is to manage the branch.

The Kaw Valley Auto Co., who represented the Mitchell for three years, has not yet announced what line it would take in place of the Mitchell.

Kansas City is to have a Fall race meet, three days, commencing Sept. 2 and ending Labor Day. Many fast cars have been entered. K. L. Bernard, racing manager for the Automobile Club of this city, left Saturday to endeavor to obtain some of the Elgin contestants.

## Montreal Longs for More Speed

MONTREAL, Aug. 28—A movement to establish certain reforms which mean much to automobile users and dealers is being advocated quietly and will probably take definite shape before the

leaves are off the trees. The prime movers hope to see their aims accomplished before the opening of the summer season of 1912. The project has two principal aims. The first, to see the speed limit law for the City of Montreal made to conform with modern ideas and conditions, and second, to have the mountain roads opened to automobiles during certain hours of the day.

F. G. Pennal and Frank Stockwell are the prime movers. If their plans mature, either a new automobile association will see light in this city or The Automobile Dealers' Association, which was brought into being at the time of the motor show last spring, will be galvanized into activity and will take the matter up.

The present speed limit in Montreal is approximately 9 miles an hour.

Drivers of automobiles in Montreal have another vigorous kick coming against existing conditions, in the manner in which the law is enforced. Mr. Stockwell says that speeding at the rate of 20 miles an hour on crowded thoroughfares like St. James street, where anything above 6 miles an hour involves a certain amount of danger, is ignored, simply because the Provincial Government entrusted with the enforcement of the law confines its attentions to boulevards, like Park avenue north.

For hill climbing also Mr. Stockwell says a low speed is undesirable. A car climbing a hill such as Beaver Hall Hill on top gear with small noise, little gas exhaust, causes infinitely less annoyance to pedestrians and householders than a car running up on low gear, emitting smoke and noises, to the irritation of all beholders.

In Toronto, the speed limit is twice as high as it is here, and in Detroit and New York it is higher still. The fact that an automobile may be handled with a much greater degree of certainty and speed than a horse, makes these limits practical in cities where the traffic is at least as congested as it is in Montreal.

Mr. Pennal is at present engaged in collecting data from all

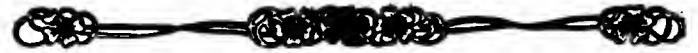

## Camping Car for duPont

Senator T. Coleman duPont, of Delaware, who recently created a sensation in the motoring world with the announcement of his determination to build a public highway running due north and south through his entire home State, is going ahead with his project.

Col. duPont's purpose is to keep in personal touch with the project and to this end has accepted delivery of a Stoddard-Dayton camping car built under his own plans.

The car is of 45-horsepower on 115 inches wheelbase, with a body specially constructed and so laid out that it has sufficient length inside to accommodate a hair mattress 6 feet long. There are two lockers about 6 inches wide, which run the length of



Stoddard-Dayton camping car specially prepared for Senator T. C. duPont, showing how tents and paraphernalia are placed or built into it

the principal give the orga  
gative compa  
data will be  
old dealers  
entered into

In regard  
mountain  
be grante  
vehicles  
o'clock  
after the  
"As  
drive a  
frighte  
to me  
the e

372

**Hoosiers Seek Modern Fry**

INDIANAPOLIS, IND., Aug. 28.—In some time ago of placing a motor squad wagon carrying eight pic eight men and a 35-gallon chemical wagon and 130 feet carry 1,000 f 500 gr. Ri.

da and the United States which will movement something to draw authori a meeting to be held shortly these e question of re-organizing the establishing a new body will be

cluding automobiles from the is that the roads should horses and horse-drawn Until three or four the limit, the roads is well as to horses. declared, "a man might it was the exception it traffic. Now it is

**Hoosier Tour**

anager of the completing d Flanders o, and re- city at entries cinity.

St  
ar  
ov  
turn, Sep.  
6 a. m., Sept. 3.  
of E-M-F and Flanders owners ...

**Rubber Company Enters Tire Field**

AKRON, O., Aug. 28.—The Miller Rubber Co., which recently added tires to the list of its products, has purchased five and a half acres of additional land near the factory in South Akron, for the purpose of making extensions. Previous to entering the pneumatic tire field, the Miller Rubber Co. confined its activities solely to rubber sundries.



the body on each side, affording packing space for supplies. The top is permanent, with a slat rack on the under side holding four vulcanized fibre provision boxes which are strapped into place over the rack. There is also a rack in the top for taking care of drawings, plans, etc., and arranged on the top of the body above this is a slat rack with an iron railing of sufficient size to carry four extra tires, which are tightly strapped to the rack.

Col. duPont's gift to the State of Delaware is a highway 103 miles long, from 100 feet to 200 feet wide, running from one end of the State of Delaware to the other. In building this road he is personally determined to see that it is built right, and he is going to superintend the construction of it himself. It will cost \$1,500,000.



Rear view of the duPont camping outfit built into and around a Stoddard-Dayton car

**Six Perfect in Lake Tahoe Run**

SAN FRANCISCO, CAL., Aug. 29.—Six cars out of fifteen finished with perfect scores to-day in second annual endurance run from this city to Lake Tahoe and return. The distance is 520 miles, a goodly part of which is through the Sierra Nevadas, rising 7,000 feet, with many very steep grades, and badly twisted roads. The cars that survived the ordeal were: American 50, Buick 26, Buick 30, Flanders 20, Franklin 18, runabout, and Winton Six.

The run proved to be unusually severe upon tires owing to heat of the valleys and severe grades over rough mountain roads. Many of the cars suffered a large number of punctures and running time was so fast that they had to use a good deal of speed to keep up with schedule.

Last year contestants complained that schedule was too slow but this year there was no complaint on this score. The schedule averaged more than 20 miles an hour on the level and over 13 miles through mountains.

**Firestone Moves into New Factory**

AKRON, O., Aug. 28.—The Firestone Tire and Rubber Co. is removing from its old to the new factory in South Akron. The Firestone Co., compelled some time ago to find more room, decided to build an entirely new factory instead of adding to its old one. About half the removal has been accomplished.

The old plant will be devoted to the manufacture of rims. One of the unique features of the new office arrangement is a complete restaurant, smoking room and dining room for office employees, with accommodations for 400 persons and what is considered the largest refrigerator capacity in the city. The management has also a plan, not yet formally announced, for supplying hot soup and other substantial to employees of the factory.

**Harking Back a Decade**

THE *Automobile Blue Book* first made its appearance ten years ago this week. It was a sort of compendium or compilation of all sorts of information likely to be of use to automobilists and its present mission as a road guide was only promised in a limited degree.

As an indication of the great strides the automobile was making at the time it was noted that the manufacture of the electric automobile and the steam automobile made by the American Bicycle Company had been transferred respectively to the Waverley factory at Indianapolis and to the Toledo factory at Toledo, Ohio.

Henri Fournier and "Tod" Sloan arrived in New York to establish an American agency for the Mors.

A note from Homburg stated that King Edward VII had two automobiles with him. One of these was equipped with a plate of glass at the back to keep off the dust.

The Daimler company was said to be busy experimenting with a car to be driven partially by benzine and partly by electricity.

A British correspondent of *The Motor Review* advises automobilists to avoid the use of goggles. His reasoning is as follows: The wearing of goggles presupposes speed and in the eyes of the police raises the presumption of illegal speed. Therefore, in order to avoid even the appearance of evil go as fast as you like but leave off the goggles.

For the first time an automobile was named as co-respondent in a divorce case. A resident of Passaic, N. J., filed a complaint upon which the onus of "breaking up the happiest home in the world" was laid at the door of a Newark man's car.

The 500-mile endurance run to Buffalo, scheduled for September 9-14, 1901, had seventy-six entries on August 31.

Announcement was made that the Chicago Automobile Club, an embryonic organization, had decided to build a clubhouse.

The *Auto Era*, house organ of the Winton Motor Carriage Company and pioneer in that field, made its debut.



**A**MERICUS, GA.—Right in the heart of the so-called dull season, a special train of nine cars loaded with Maxwell automobiles is on its way from the factory to this place consigned to the Americus Automobile Company. The cars are all equipped with the special 60-inch tread which is required for operation on Southern roads. The extra four inches of width is always included in Maxwell cars destined for the Southern market.

**PLAINFIELD, N. J.**—The Spicer Manufacturing Company has announced the installation of an electric vehicle charging station and service department.

**BOSTON, MASS.**—The Stutz car is now represented in Boston, an agency for it having been opened last week by the Empire Motor Car Company as an addition to its line.

**INDIANAPOLIS, IND.**—The Indiana Four States Tour was such a success that the automobile builders of this State have organized a State society. This took place recently at a picnic to celebrate the 1,500 miles trade boosters' tour.

**BOSTON, MASS.**—George Parker, who for a long time was identified with J. H. MacAlman, selling Columbia and Stearns cars in the Hub, has gone over to the commercial field and he is now sales manager of the Mack Motor Truck Company in this city.

**LANSING, MICH.**—Since the first of the year Secretary of State Martindale has collected automobile license fees amounting to \$93,000, which is an increase of \$20,000 over last year. The number plates for next year will be black numerals on an orange background.

**PORTLAND, ORE.**—Preparations for a dash into the Arctic zone are being made upon the Abbott-Detroit "Bull-Dog" which is

now in this city. The car will be fitted with hickory runners on the front wheels and metal studded tires on the driving wheels. The car has done about 32,000 miles so far.

**RACINE, WIS.**—The automobile department of the J. I. Case Threshing Machine Co., Racine, Wis., is making exhaustive tests of a new type of rear axle which is being manufactured by the Green Engineering Co., of Racine, owner of the patent rights. If found entirely satisfactory the axle will be incorporated in all 1912 Case cars, it is stated.

**LANSING, MICH.**—T. Earle Jarrard, who for the last five years has been connected with the Reo Motor Car Company and the R. M. Owen Company, will leave the city in a short time to accept a position with the Apperson Brothers Automobile Company, of Kokomo, Ind. Mr. Jarrard will be assistant to Elmer Apperson, who is president and general manager of the concern.

**AKRON, O.**—H. J. Woodard, for some time manager of the New York store of the Diamond Rubber Co., has resigned and taken a position as sales manager with the Century Tire Co., of New York. He is succeeded in the Diamond branch by N. E. Oliver, who has been manager for Buffalo, and who will still oversee the activities at Buffalo in addition to his New York responsibility. A. J. Henry, of Akron, will assist Mr. Oliver in the conduct of the Buffalo branch.

**BOSTON, MASS.**—Manager C. P. Rockwell of the Boston branch announced, following his visit to the conference at the Rambler factory last week of the branch managers, that arrangements had been completed to erect a new home for the Hub branch on Commonwealth avenue in the near future. The Boston branch now has

one of the finest salesrooms in Boston, but the officials of the Thomas B. Jeffrey Company want to have the repair department and salesrooms in the one building.

**FINDLAY, O.**—The Norwalk Motor Car Company, Norwalk, Ohio, has been adjudged a bankrupt in the United States court at Toledo, Judge Killlets sitting. A. J. Schur, of Cleveland, an attorney, has been appointed receiver with bond at \$20,000. The plant will be operated by the receiver. The proceedings were brought by the Diamond Rubber Company, of New York; the Pennsylvania Rubber and Supply Company, of Cleveland, and the Cross-Gilchrist Advertising Co., of Cleveland.

**LANSING, MICH.**—The Olds Motor Works is about to spend \$215,000 for the erection of a modern factory building replete with fine equipment. Upon its completion 500 men will be added to the present force, making the total number of employees about 1,800. The W. E. Wood Construction Company, of Detroit, has been given the contract. The structure will be built of brick with reinforced concrete foundations and steel sash throughout. It is expected the structure will be finished in four months.

**LOUISVILLE, KY.**—Paducah motorists are in hearty accord for the establishment of a model highway from Louisville to Paducah, as suggested by Rusli C. Watkins, president of the Louisville Automobile Club. The Paducah automobile owners have reorganized their association and will assist in securing improved roads in Western Kentucky. It has been proposed to improve the road from Paducah to Hopkinsville, where the Jefferson Davis Way can be tapped. The road from Louisville to Paducah is at present seldom used because of the poor condition of the highway.

# Automobile Incorporations

## AUTOMOBILES AND PARTS

CINCINNATI—Great interest attended the appearance of the new automobile fire engine, just completed for the city, by the Ahrens-Fox Co. For the test it was loaded with fourteen men, and ballast equal to its complement of hose.

CINCINNATI—President Pratt of the Ohio Motor Co. left yesterday on a trip to Canada via Cleveland, Buffalo and Toronto and will be absent about two weeks. He has named The Federal Motor Car Co. as representative of the Ohio company for Pittsburgh and Western Pennsylvania.

COLUMBUS, O.—The contract for supplying 40,000 or more sets of number plates to the Ohio State Automobile Department for the year 1912 has been awarded to the Scioto Sign Company, of Kenton, O., at 23 1-2 cents per set. The 1912 tags will be in green on a white background of enamel. The tags are to be numbered consecutively and the first delivery is to be made November 1. The tags are to contain the word "Ohio" and the figures 1912.

LOS ANGELES—Southern California has a telephone service that is unique, being a system of roadside stations for the use of automobile drivers in case of emergency. For instance, in case of a breakdown, it will not be necessary to walk for miles to the nearest telephone toll station, as the new system provides a portable telephone outfit for the car of each member. All that is required is to "plug in" at one of the numerous telephone poles which have been converted into emergency stations, and 'phone to the nearest garage.

AKRON, O.—The Goodyear Tire & Rubber Co. is preparing to have a storage lake, or pond, in East Akron, as a source of water supply when other sources are interfered with, so that water famines or the stoppage of regular sources of supply may not at any time necessitate the closing of their factory. Recently the company purchased eighteen acres of ground in the vicinity of Kelly avenue, and a dam is being built across the lower end of the property, so that about six feet of water will be backed up as far as the line of the property the company has acquired.

ATLANTIC CITY, N. J.—Atlantic Perfected Motor Co.; capital, \$300,000; to manufacture automobiles and engines. Incorporators: Frank Brown, Thos. Kilcourse, Samuel S. Pfoebus, John S. Ingram.

AUGUSTA, ME.—Autocart Co., capital, \$15,000; to make automobiles and trucks. Incorporators: Chas. H. O'Brien, Lewis A. Burleigh.

BROOKLYN, N. Y.—Mobr Auto Co.; capital, \$25,000; to manufacture automobiles and parts. Incorporators: Henry Mohr, Max Keve, Charles Goldstein.

CHICAGO, ILL.—Automobile Construction Co.; capital, \$27,000; to manufacture automobiles. Incorporators: Albert T. Grabam, H. M. Wells, Wm. E. Fuller, Geo. F. Mulligan.

CHICAGO, ILL.—Simplex Auto-Cranker Co.; capital, \$100,000; to manufacture automobiles, supplies and machinery. Incorporators: Edwin A. Gardner, Ignatius F. Halton, Willard Patrick, P. W. Rosenstone.

CINCINNATI, OHIO.—Rambler Motor Car Co. of Cincinnati; capital, \$25,000; to deal in automobiles and supplies. Incorporators: Geo. H. Jung, F. D. Ratterman, Charles Reed, W. H. Kaufman, Walter C. Reed.

HOPKINSVILLE, Ky.—Caye-Jones Motor Co., capital, \$10,000; to make automobiles.

JERSEY CITY, N. J.—Studebaker Corp. of America; capital, \$100,000; to manufacture automobiles. Incorporators: M. Gregg Latimer, John B. Marsh, John R. Turner.

LOUISVILLE, Ky.—Wilder Motor Car Co.; capital, \$5,000; to sell, repair and rent automobiles.

NEW YORK, N. Y.—Bergdoll Motor Car Co.; to manufacture automobiles; capital, \$10,000.

PONTIAC, MICH.—General Motors Co.; to manufacture electric trucks.

RICHMOND, VA.—Virginian Sales Co.; to sell Virginian automobiles. Incorporators: Louis Hartig, Louis Hartig, Jr.

TOLEDO, OHIO.—Toledo Annealing Charging Truck Co.; capital, \$10,000; to make motor trucks. Incorporators: John G. Blum, M. G. Blum, Joseph M. Rutherford, Edward F. Abbey, Racheal E. Rutherford.

## AUTOMOBILE GARAGES, ACCESSORIES, ETC.

CAMDEN, N. J.—American Tire Protector Co.; capital, \$1,000,000; to manufacture tire protectors and punctureproof tires. Incorporators: Robert B. Watson, John P. Donabue, Robert St. John.

DETROIT, MICH.—Climax Motor Parts Co.; capital, \$50,000; to manufacture accessories.

HOBOKEN, N. J.—Imperial Garage Co.; capital, \$10,000.

JERSEY CITY, N. J.—The Marquette Co.; capital, \$10,000; to manufacture motors. Incorporators: S. B. Mantz, H. A. Black, John R. Turner.

MILWAUKEE, Wis.—Motor Convenience Co.; capital, \$30,000; to manufacture various accessories. Incorporators: Charles F. Pullen, George D. Londerbeck, I. W. Davis.

NEW YORK, N. Y.—Consolidated Lubricants Co.; capital, \$25,000; to make and deal in lubricating oils, greases, etc. Incorporators: Arthur R. Pardington, Warren L. Sawyer, Jos. N. Patch.

NEW YORK, N. Y.—United Rubber Co.; capital, \$100,000; to manufacture rubber goods. Incorporators: Ada A. Sands, Eva C. Baker, Frank B. Vermilya.

NEW YORK, N. Y.—Automatic Fender Co. of America; capital, \$1,000,000; to manufacture automobile fenders. Incorporators: Wm. M. McGuirk, Saul S. Myers, Wm. E. Lowther.

SCHENECTADY, N. Y.—Union Lubricating Co.; capital, \$25,000; to manufacture and deal in lubricating oils. Incorporators: J. W. Nagle, Edward H. Robinson, M. C. Cahill.

SHAWANO, Wis.—Frogner Auto Co.; capital, \$5,000; to conduct a general garage business. Incorporators: A. G. Frogner, C. E. Dunn, E. M. Williams.

## A New Ball-Bearing

Joseph Schaeffers, one of the early members of the S. A. E., has returned from his European trip, bringing with him the sole U. S. agency of one of the well-known German ball bearings, the H. C. B. bearing, made by the H. Hollmann Company, in Burgsolms, Lahn.

The bearings have a solid, patented, two-part, wire-stitched cage, as shown in Fig. 2, or a sheet-steel retainer, or one consisting of two pieces only and protected by patents, as shown in Fig. 3. Among the particular features of these bearings two types for combined radial and thrust load may be mentioned. Fig. 4 shows a cross-section. These types have an angularity of contact between balls and raceways, this angularity being 30 degrees in the one, and 45 degrees in the other type, and these types are particularly well adopted for taking the combined loads of bevel gear shafts.

For all places where warping or sagging is liable to bring the shaft and the housing of the ball bearing out of alignment, a new and patented type of bearing has been placed upon the market. Fig. 1 shows a cross-section. The H. C. B. bearings are made of the finest German chrome tool steel from the Becker Steel Works, and are hardened and inspected, ground and inspected, assembled and inspected with care and thoroughness.



COLUMBUS, O.—The Ohio State Highway Department at Columbus, O., with the assistance of the Ohio Good Roads Federation gave a roads exhibition at the Ohio State Fair during the week of August 28 to September 1. The highway department at Washington, D. C., sent displays and models relating to the subject of good roads construction and the exhibits were complete in every respect.

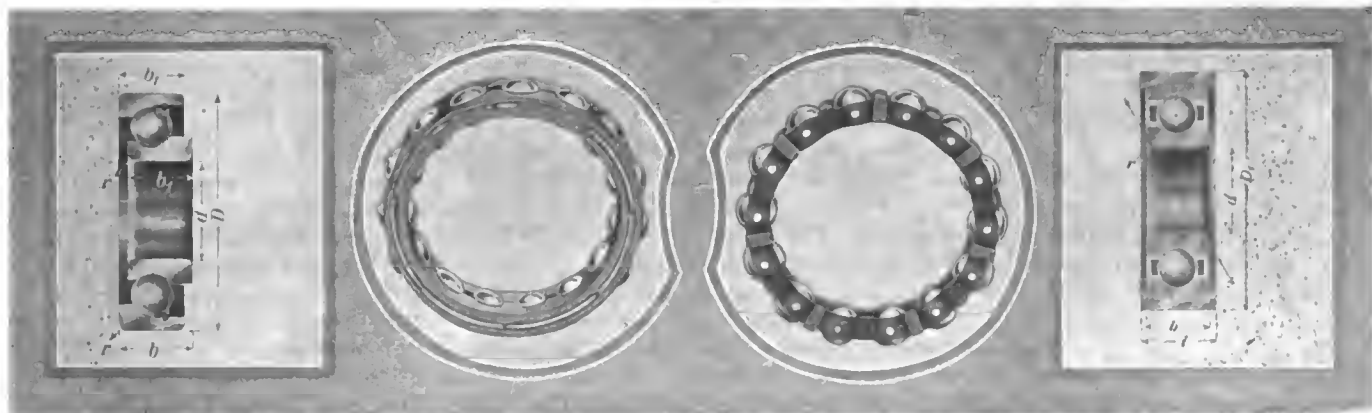

Fig. 1—Cross-section of anti-disalignment H. C. B. bearing. Fig. 2—Wire stitched cage type of ball bearing. Fig. 3—Two-piece steel-cage bearing. Fig. 4—Cross-section of ball bearing for radial and thrust loads combined





Stearns 5-ton truck purchased by the House of Correction, Chicago, for the transportation of prisoners

**BOSTON, MASS.**—William Blanchard has been appointed sales manager of the Lenox Motor Car Company here, having succeeded Frank V. Cooke.

**WASHINGTON, D. C.**—The Commercial Automobile & Supply Co. has taken the Flanders electric agency and will handle it in connection with the E-M-F and Flanders.

**PHILADELPHIA**—"The Tire Shop" has removed from 1326 Vine street to larger and more suitable quarters at 225 North Broad street, in the heart of Automobile Row. David Scannell is the proprietor.

**ZANESVILLE, O.**—Edward B. Raemer, formerly advertising manager for the Flash Manufacturing Company, is now engaged as manager of the Valley Motor Company, of this city, handling the Overland line of cars.

**ROCHESTER, N. Y.**—The Selden Motor Vehicle Company announces the appointment of James Joyce as manager of sales and that of Fred A. Law as head of its engineering and production departments.

**WASHINGTON, D. C.**—The Carpenter Automobile Co. has sold its garage at Seventeenth and U streets, N. W., to Francis P. Blair, who will take possession on September 1. Extensive improvements will be made.

**CHICOPEE FALLS, MASS.**—W. Bonsor, late of the Packard Motor Car Company, is now associated with the Stevens-Duryea Company in the production department of the factory in the capacity of supervisor of parts.

**ROCHESTER, N. Y.**—F. M. Hoblitt, general manager of the Rector Engineering Company, of New York, will devote part of his time as manager of the wholesale department of the Selden Motor Vehicle Company.

**BARABOO, WIS.**—The Gollmar Garage is erecting a fine new garage building to include a large repair shop. It will cost about \$8,000 and will be one of the most modern garages in the smaller cities of Wisconsin.

**BOSTON, MASS.**—Willard M. Jenkins, who has handled the Mitchell line in the Hub ever since it was introduced there, has added the Abbott-Detroit to his line, and may probably also take on the Krit.

**ITHACA, N. Y.**—The J. B. Lang Engine and Garage Company has completed a fire-proof garage 75 by 200 feet in which no pillars are used. Separate stalls that can be securely locked are provided for the storage of customers' cars.

**CHICAGO**—In addition to offices just opened at Minneapolis, Kansas City and Indianapolis, the Stewart & Clark Manufacturing Company is opening a new office at Cleveland, Ohio, at 1849 Euclid avenue, in charge of H. A. Ungar.

**BOSTON, MASS.**—The Abbott Motor Company, of Detroit, Mich., has just consummated a large contract with the W. M. Jenkins & Company, 288 Columbus avenue, Boston, Mass., as distributors for New England for the Abbott-Detroit line.

**MILWAUKEE, WIS.**—The Lion 40 has secured representation in Milwaukee, Wis., the agency being in charge of Charles E. Gavin and John G. Koerner, with headquarters in the Majestic building. A new garage and salesroom is being erected for the firm.

**DETROIT, MICH.**—Robert C. Winlow, formerly assistant purchasing agent of the Packard Motor Car Company, has accepted and is now occupying the position of general purchasing agent of the Grabowsky Power Wagon Company, 1735 Mt. Elliott Avenue, Detroit, Mich.

**HILLSBORO, O.**—R. D. Currie has recently opened a garage and repair shop at the intersection of West and Walnut streets, Hillsboro, O. The establishment contains 11,392 square feet of floor space and is one of the largest in Hillsboro.

**BALTIMORE, MD.**—H. S. Block, formerly connected with Waterman Brothers' Company, of California, has accepted the position as manager of the local branch of the Stoddard-Dayton Automobile Company. Leo H. Shaab, formerly manager, will be associated with the sales end of the local business.

**PONTIAC, MICH.**—R. McCracken, who has for some time been in Pontiac, reorganizing the office, factory and accounting system of the General Motors plants, and at the same time acting as comptroller, will leave shortly for Detroit, where he will take an important position in the office of the General Motors Company.

**LANSING, MICH.**—Arrangements have just been consummated whereby the General Motors Company will acquire ownership in a company manufacturing electric trucks. An entirely new manufacturing organization will be built up with John M. Lansden, formerly president of the Lansden Company, of Newark, N. J.

**FLINT, MICH.**—Before the close of the month it is expected the new plant of the Mason Motor Company will be in operation, according to Arthur Mason, general manager of the concern. Though the company has been organized only about three weeks, half of the machinery to be used in the manufacture of engines has been installed.

**MILWAUKEE, WIS.**—The Bates-Odenbrett Auto Co., 503-507 Broadway, has been appointed State distributor for the White pleasure and commercial cars and the Abbott-Detroit line. The Overland line has been discontinued and will be represented by the Motor Car Sales Co., 136 Oneida street, Milwaukee, which will also represent the Marion.

**WASHINGTON, D. C.**—The Marion Motor Car Company has leased the salesroom at 1333 Fourteenth street, N. W., now occupied by the Wilson Co., agents for the Cole and Krit. The latter will have temporary quarters with the Terminal Taxicab Co., pending the selection of a new salesroom. The Marion company will handle the Marion and American.

**DETROIT.**—The Emil Grossman Company has removed its Red Head spark plug factory to this city from New York. The plant, consisting of three floors, is located at 844 Woodward avenue, and the local display room has been removed from 874 Woodward avenue to the above location. As announced the Emil Grossman Company will fill orders from its New York, Chicago and Detroit quarters on an equal basis.



**SPRING TIRE**—A combination of two rims with a series of springs placed between them.

4. This spring tire (Fig. 1) is composed of two rims, the space between which is enclosed by means of plates arranged oppositely. Between the rims S-shaped springs are located; also stops carried on rings which are mounted on the plates mentioned. The stops permit a movement into the rings and out of engagement with the springs, arms being provided which project from the rings through the side plates located in the space between the two rims and which are movable to effect circumferential movement of the rings and the stops carried by them.

No. 1,000,796—To Jacob Whitfield Graham, Raritan, N. J. Granted August 15, 1911; filed November 8, 1910.

**FENDER**—Being a new form of bumpers to be used on automobiles.

4. The patent covers the securing to an automobile of a number of brackets by means of pivots, means for holding the brackets in their adjusted positions, clamping members adjustably secured to the brackets and springs secured intermediate their ends to the brackets and at their (the springs') ends movably secured to a buffer bar, with resilient cushioning members disposed intermediate of the clamping members and buffer bar.

No. 1,000,668—To Edwin K. Conover, Paterson, N. J. Granted August 15, 1911; filed June 16, 1910.

**INTERNAL COMBUSTION GAS TURBINE**—Combining the rotary and reciprocating principle.

1. This patent relates to an engine comprising a rotor with radially disposed, open-ended spiral passages, a driving shaft being rigidly fixed to the rotor and an elongated cylinder within the rotor, extending in line with the drive shaft. The cylinder has a series of passages arranged in line with those of the rotor and a piston rod is slidably mounted on the cylinder, a plurality of piston heads being mounted separately on the piston rod. An inlet port with a



valve to control it is provided in the cylinder, and the inlet end of the cylinder and the space between the piston heads are connected by means of a valve-controlled passage. A spark plug is so situated as to be able to ignite an explosive mixture in the space between the piston heads, in timed relation with the piston rod movements. The piston rod and driving shaft are connected through a mechanism which serves to reciprocate the piston rod in timed relation with the rotation of the shaft.

No. 1,000,882—To Edwin Atwell, Baltimore, Md. Granted August 15, 1911; filed August 4, 1910.

**ODOMETER**—A mile meter of the type which is directly connected to the hub.

2. The register which is shown in Fig. 3 is supported by the hub and a shaft, an eccentric being mounted eccentrically in the wheel hub, where is also mounted a ratchet wheel with which a bevel gear is concentrically mounted. An eccentric link is mounted in the hub and connected to a pawl carrier, having a pawl and being mounted concentrically with the ratchet wheel. The bevel gear above mentioned meshes with another bevel gear connected to the register, a gear on the register shaft

engaging loosely with the bevel gear and another gear secured to the end of the axle.

No. 1,000,861—To Curtis Hussey Veeder, Hartford, Conn., assignor to the Veeder Manufacturing Company. Granted August 15, 1911; filed January 12, 1911.

**SPANNER-WRENCH**—This is descriptive of a wrench with one jaw having a convexly curved face and the other fitted for various sizes of nuts.

5. By this patent is covered a wrench for nuts of different sizes. The spanner end has a convexly curved jaw apt to engage a nut facet, the other jaw having several plane grip faces each capable of engaging a certain size of nut upon a facet diametrically opposite to the nut facet engaged by the curved jaw. Each of the grip faces of the second jaw is parallel to the tangent of the first (curved) jaw at the point of engagement, thereby permitting of securely gripping the nut. The wrench jaws are so proportioned that the spanner may rotate in one direction.

No. 999,968—To Edwin A. Denham, assignor to the Erie Wrench Co., of New York, N. Y.; granted August 8, 1911; filed September 10, 1910.

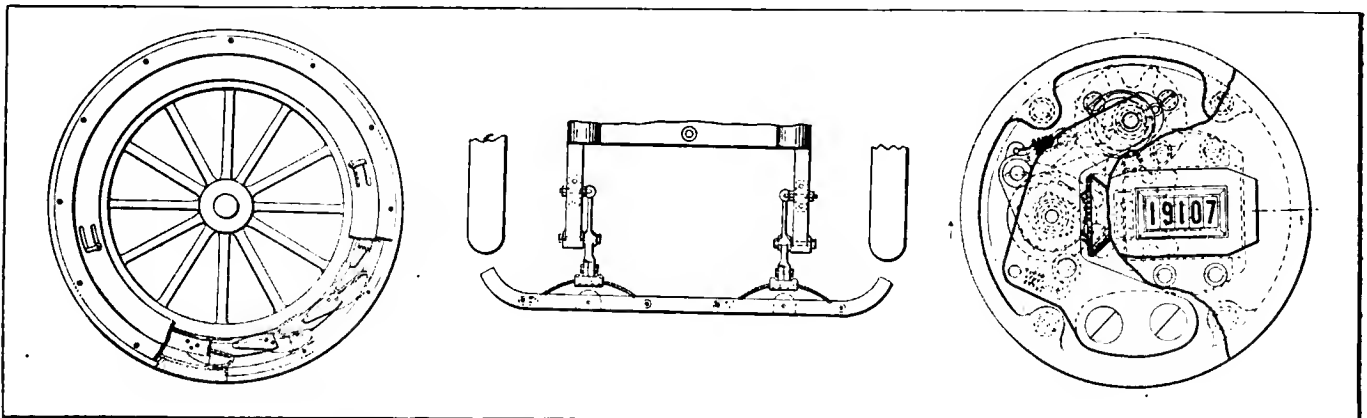

Fig. 1—Illustrating the spring-tire patented by J. W. Graham

Fig. 2—Showing the new Conover automobile safety fender

Fig. 3—Mechanism of the latest type of Veeder odometer

## Seen in the Show Window

**S**TRENGTH of sound is the chief claim made for the Typhoon electric horn, which is illustrated at CG. The type shown consists of a motor enclosed in the short cylindrical part of the horn and which serves to excite the sound waves in the air. The sound on its travel out of the device is considerably intensified by the horn proper or megaphone, as it might be called, which is about three times as long as the motor portion and serves to strengthen considerably the sound produced by the motor. This latter is connected to a battery, either a storage battery or a set of dry cells, and operated by pressing a button on the steering wheel or wherever the automobilist finds it convenient to install it. The interior members of the horn are of such material as will warrant longevity on their part, and the "megaphone" is made of strong brass, thus making for a pleasing appearance. The signal is the product of the Typhoon Signal Company, whose factory is located at 1389 Milwaukee avenue, Chicago, Ill.

**C**OMPLAINT of car owners is not unfrequently aroused by the cold temperature obtaining in the automobile in Wintertime, and to do away with this troublesome state of things the Al-Ton car heater, shown at CH, will be a good thing to place in an automobile. This heater utilizes the waste heat of the exhaust which by the use of a by-pass valve is led through several pipes located under the metal net work shown in the illustration. After passing through the heater, the exhaust is conducted to the muffler in the usual way, and since the construction of the apparatus obstructs the flow of the gases in no way, no back pressure is caused by the use of the heater. The Al-Ton Motor Accessory Company, South and High streets, Akron, Ohio, makes this device.

**H**EATED gases expand in exhausting and thereby produce a noise, especially if the expansion of the gases is handicapped in any way. To reduce the noise caused by the expanding exhaust gases silencers are used, and it stands to reason that if the gases instead of through the muffler are passed through a suitable pipe or whistle a very efficacious signal may be produced in this way. At CI a whistle of this type is shown which is connected up to the exhaust lead, but normally closed by a valve. If the valve is opened and the gases allowed to enter the whistle a rich, mellow note is produced which is easily heard for a mile ahead of the car. The Eagle whistle is made by the Eagle Whistle Company, of Boston, Mass.

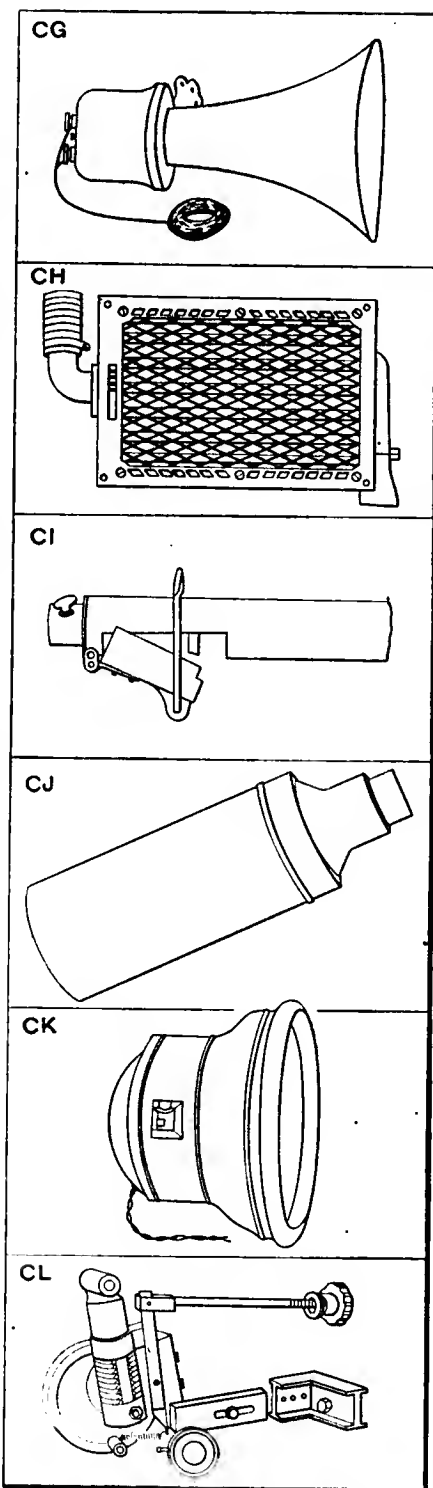

CG—Typhoon horn, operated electrically from the dash  
 CH—Al-Ton car heater used gases flowing to muffler  
 CI—Eagle whistle utilizing exhaust to produce signal  
 CJ—Vaco bottle keeps liquids hot or cold at will  
 CK—Columbus electric headlight comes in brass or black finish  
 CL—M. & L. crank-operated reciprocating tire pump

**E**VERYTHING which makes for comfort in touring is welcomed by automobilists, and a very useful accessory which serves this end is shown at CJ, this being the Vaco bottle, made by the Caloris Company, Philadelphia, Pa., for the purpose of keeping liquids warm or cold for a considerable length of time. The bottle which is transported in a metal container has a double wall of thick glass, the space between the two walls being hermetically sealed after the air has been exhausted from it. The practically empty space prevents heat from passing through it either into or out of the bottle, so that it is capable of keeping liquids ice cold for three days or boiling hot for twenty-four hours, if the bottle is stopped up tightly by the cork. In addition to these features, the bottle may be used to keep milk sweet for any length of time without the use of ice or any cooling substance.

**L**AMPS, especially headlights, are now very frequently of the electric type, owing to the great illuminating power and cleanliness of this class of lighting equipment, and the illustration CK shows a well-known standard type, this being the product of the Columbus Auto Brass Company, Columbus, Ohio. The lamp is made of brass throughout, with a reflector provided on the inside, the inner space of the lamp being closed up by a heavy glass plate. The lamp here illustrated is a headlight, and while the regularly furnished type is finished in brass, a black effect may also be secured if the purchaser so desires.

**L**ONGEVITY of tires depends upon their being fully inflated at all times, and while the old style of hand pump is something of an inconvenience the M. & L. tire pump, seen at CL, does away with the bulk of the trouble arising from the operation of such a pump. The M. & L., which is furnished with 12 feet of high-pressure hose and all necessary connections and is guaranteed for a year, may be used to pump the tires up to 90 pounds pressure within three minutes time. The operation is simple: the hose is connected to the tire valve and the hand wheel of the pump turned. A gauge attached to the pump indicates the pressure in the tire. The pump may be attached to any type of automobile, and is bound to operate, since the handwheel through a crankshaft reciprocates the plunger in the pump cylinder which is air cooled by means of cannellations on its surface. This pump is made and sold by the Migeot Machine Company, of 333 North Fourth street, Philadelphia, Pa.

# THE AUTOMOBILE

## Motorizing Gotham's Fire Apparatus

### Past, Present and Future of Power Equipment

*Commissioner Johnson of the New York Fire Department is handling a campaign which has for its objective point the installation of 150 pieces of automobile driven fire-fighting machines of all varieties. Twenty-nine pieces are now in commission throughout the five boroughs and by March 1, 1912, it is expected that there will be 100 more in service and at least fifty additional by the end of next year.*

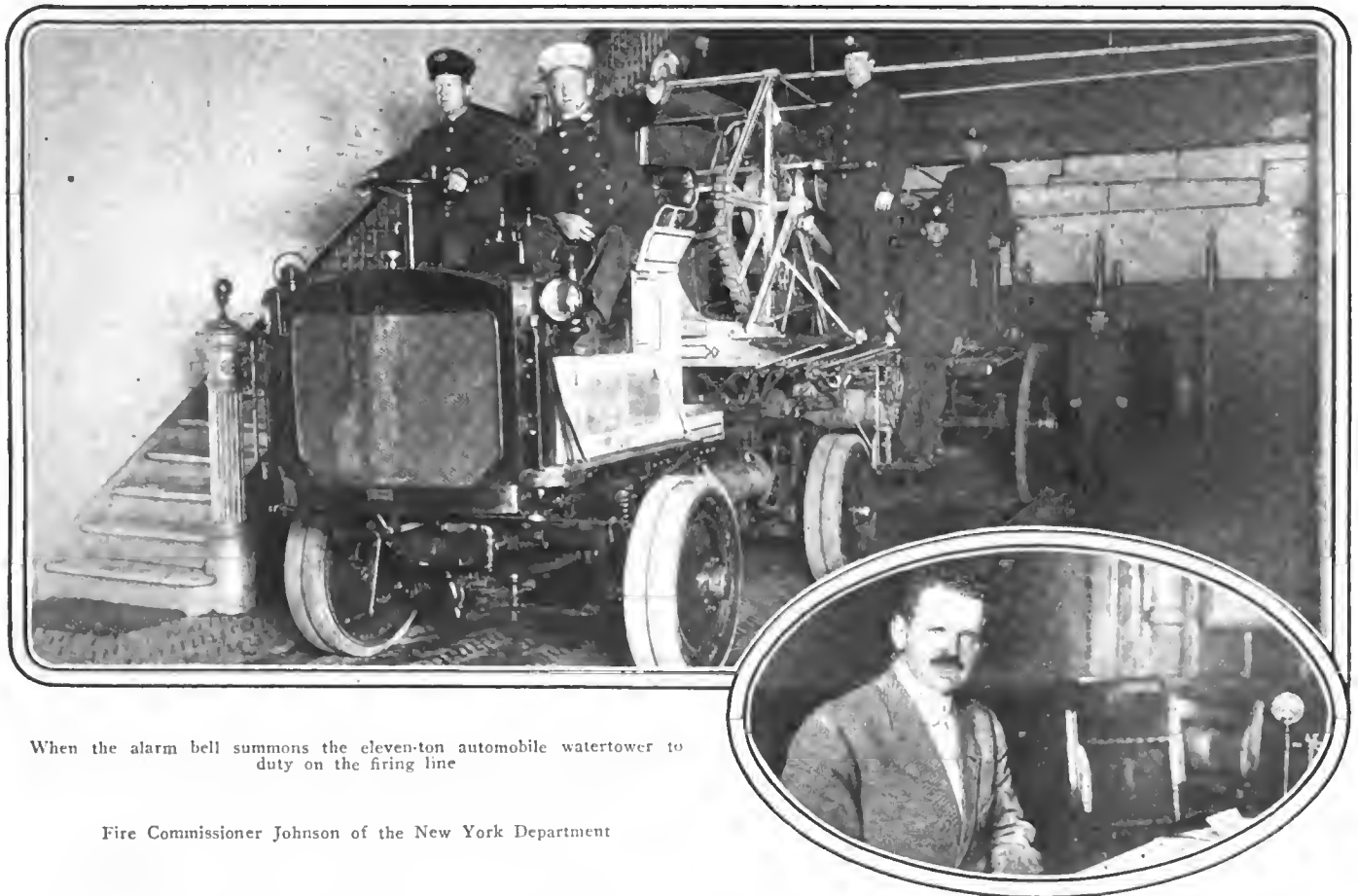

When the alarm bell summons the eleven-ton automobile watertower to duty on the firing line

Fire Commissioner Johnson of the New York Department

**M**OTORIZATION of the New York Fire Department is probably the most important step that will be taken in the immediate future as far as the progress of the automobile as a factor of utility work is concerned. The undertaking is gigantic and marks the commencement of a new era in the use of the automobile in municipal work. Not that there is not already much use being made of the automobile in fighting

fires, because a start in that direction has been made and power-driven fire-fighting apparatus has been installed widely and has proved efficacious; but the future holds an immense significance along that line and progress indicated by the recent action of Fire Commissioner Johnson in preparing for the installation of 150 pieces of apparatus depending upon gasoline power for their propelling force shows that the pioneer work has borne fruit

and the universal vogue of the fire automobile is now at hand.

When 1913 opens the Fire Department of New York City will have by far the most complete equipment of automobile fire-fighting machines in the world. The city has tested and tried various makes of machines and to-day has twenty-nine cars in the department's service. Of these, nineteen are touring cars and runabouts used in transporting the commanding officers to their stations of duty at fires and elsewhere. The remainder are in fire-fighting service and include one Nott tractor of 110 horsepower attached to a steam engine, three Webb high-pressure hose wagons equipped with 66-horsepower motors, one Knox high-pressure hose wagon of 50 horsepower, one Couple-Gear water-tower, the motor of which is operated by electric current developed by a 40-horsepower, four-cylinder gasoline engine, two Victor trucks used as supply wagons and equipped with special stake bodies and two Knox trucks in the same branch of service. All four of the latter wagons are of 1 1-2 tons capacity.

shod with tires 48 by 6 inches. The motor is a marvel of size, the four cylinders measuring 5 3-4 by 8 inches and developing 110 horsepower on the brake test. This engine has been in the repair shop for twelve days since it was put in service, the result of an accident that caused a leak in the radiator. Otherwise it has given not an atom of trouble to its crew. David J. Oliver, who drives the immense automobile, had a large share in its assembly, going on to the factory to familiarize himself with the mechanical details of the motor. The district in which the Nott engine is stationed has more than the average amount of work and on a basis of 500 miles since the engine was put into commission the yearly mileage would be in the neighborhood of 1,000.

In buying motor apparatus the department is not providing for one or two years of service, but is working for equipment that will last for many years under the excellent care that is given all fire apparatus and the limited mileage required of it.

The requirements of the department are high and hard to

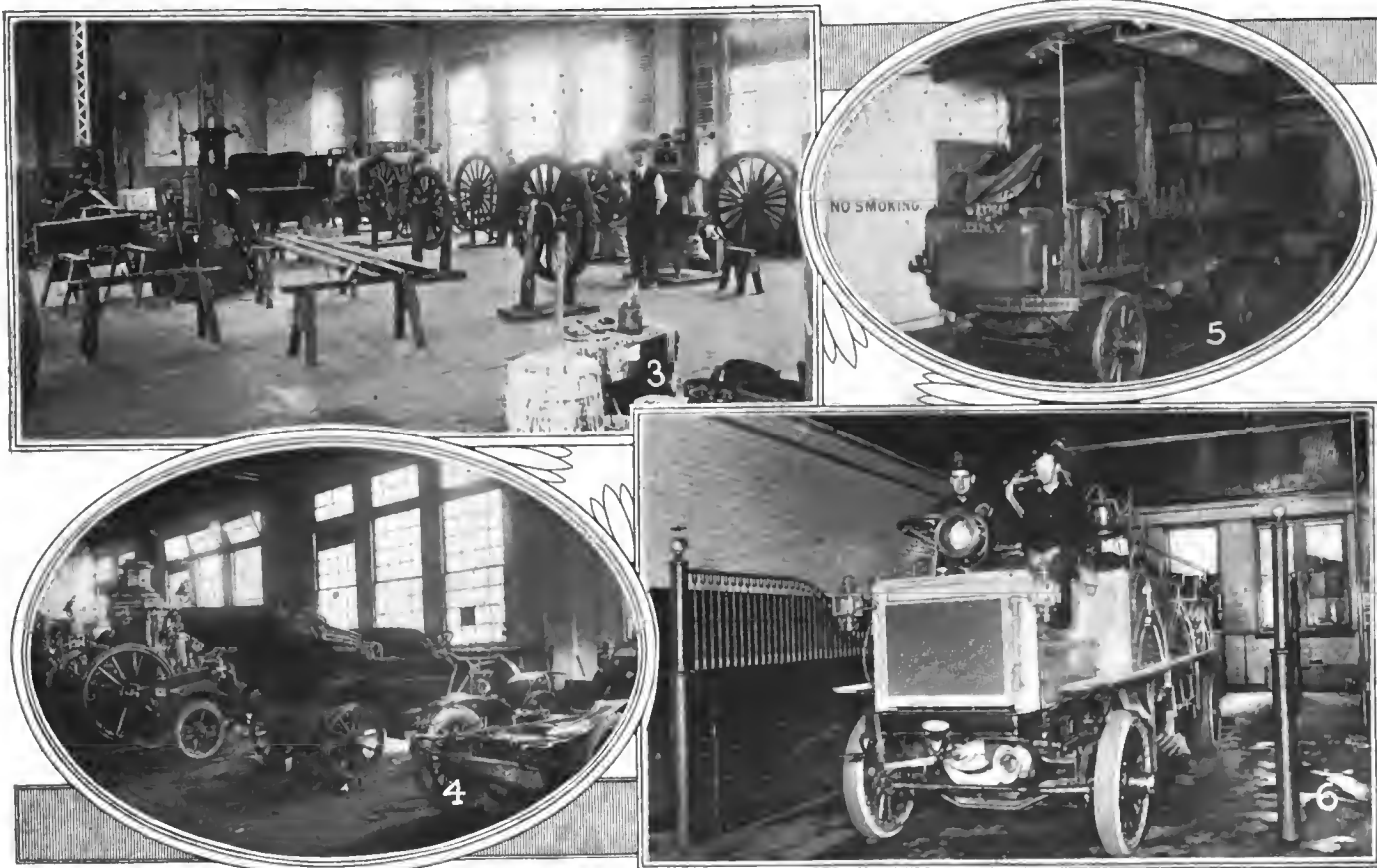

3—Painting section of the big repair department for motor apparatus  
4—Automobiles of the department as well as fire apparatus need repairs

5—Knox 1½-ton truck used as a supply wagon, displacing six horses  
6—Webb high-pressure hose wagon stationed in "58's" house

During the rain last week a representative of THE AUTOMOBILE with a staff photographer made the rounds of the fire houses to obtain data and illustrations for this article, using a 32-horsepower Moon car of 1912 model, which was furnished by the courtesy of the New York branch of the Moon Motor Car Company.

The situation at present indicates much satisfaction with the apparatus operated by mechanical power and much enthusiasm on the part of the men of the department who are in contact with the machines.

At Engine Company 58, on One Hundred and Fifteenth street, near Lenox avenue, is stationed the solitary steamer owned by the department. This engine is attached to the Nott tractor, and since last March, when it was installed, it has traveled nearly 500 miles in fire service. The complete apparatus weights about nine tons. The rear wheels are fitted with the biggest solid tires ever made, they being 60 by 6 inches, while the front wheels are

comply with, but an immense effort is apparent upon the part of manufacturers to gain a definite idea of the requirements with the intention of submitting bids in the near future.

Another piece of apparatus that is stationed at Engine House 58 is a Webb high-pressure horse wagon, manufactured by the Webb Motor Fire Apparatus Company. This wagon is driven by a four-cylinder, four-cycle motor, 5 1-4 by 6 inches, and rated at 66 horsepower. The motor is of the Herschell and Stillman type. The body is fitted with riding accommodations for ten men, including the driver, and carries 2,100 feet of specially strong three-inch hose. In the high-pressure district of New York no pumping engine is required to throw water high into the highest of the skyscrapers. It is said that the pressure is sufficient to raise water over 200 feet without the aid of pumps. In a cradle back of the driver rests a giant nozzle which has four connections to which leaders from the high-pressure mains may be attached.



The car is comparatively light and has high speed, and so far has shown some creditable work in service.

There is another Webb wagon at Engine House 72, on Twelfth street, near University place, and still another is in the supply department ready to be assigned a regular station on the fighting line. At 72's house there is also a Knox high-pressure hose wagon similar in body design to the Webb, but with a 50-horsepower motor.

The biggest piece of fire-fighting machinery in the equipment of the department is the watertower No. 1, stationed at 31's engine house on Lafayette street.

This machine is driven by a Couple-Gear motor and all told weighs 11 tons. The electric power is generated by a gasoline motor and each wheel is driven by its own power device.

The body carries a watertower arranged to be raised and lowered on a quadrant base. The vehicle is said to be capable of an average speed of 15 miles an hour.

contains a school room which is being used for the instruction of chauffeurs and mechanics to drive and care for the motor-driven apparatus.

Last Thursday Professor Butler was completing the instruction of a class of firemen at the time of the visit of the representative of THE AUTOMOBILE. This class has finished its work in ignition, lubrication and other studies that may be pursued indoors and during this week will take up the driving instruction and actual repair work.

So much for the present equipment of the department. The indications for the future are for a condition that seems almost revolutionary. The department has three-quarters of a million dollars to spend for motor fire engines of various styles, sizes and duties and the specifications for the first batch of apparatus are being prepared by the technical board, which consists of Deputy Fire Commissioner P. P. Farley, chairman; Chief Kenlon, Battalion Chief J. P. Howe and Captain Demarest. This

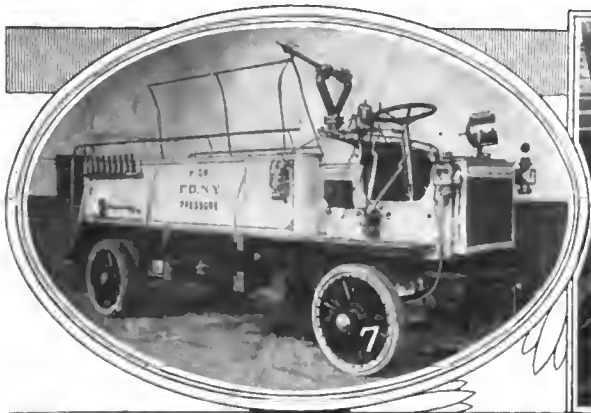

7—Webb wagon of 66-horsepower awaiting assignment in the line of battle  
8—Victor truck of 1½ tons and 30 horsepower used as a supply wagon

10—The machine tools of the department are sufficient for much work  
9—Where the tires of the fire department are adjusted and inspected

Some idea of the advancement in fire fighting that is shown by the operation of these immense wagons may be realized when one remembers that the limit of size for horse-drawn engines and equipment was marked at three tons. The engine at 58 weighs nine tons and the watertower weighs eleven tons, with all that those figures mean in the way of added power, speed and efficiency.

The other four wagons in present use are the 1 1-2-ton trucks assigned to the supply department under general charge of Captain Charles S. Demarest, chief of the bureau of repairs.

Captain Demarest's headquarters are at the foot of West Fifty-sixth street, where the fire department has a very complete repair and service department.

There is a special room devoted to each branch of repair, including a room for chassis assembling, forge room, foundry, storage and garage, machine tools, tires, body work, painting and varnishing and testing. Besides these branches, the department

lot of equipment will probably include about ten pieces and the chances are that they will be installed before the last of the year. During the interim specifications for other lots will be framed and delivery will be available at short intervals during the Winter. It is expected that about 100 pieces will be ready for service by March 1, 1912. By the first of 1913 it is expected that the department will have in service at least 150 pieces of motor machinery.

Among the companies that are taking a keen interest in the proceedings of the technical board and which are in constant touch with its activities are the following: Peerless, Garford, Gramm, Nott, Knox, Webb, Watrous, Ford, Lozier, Packard, White Combination Hook and Ladder and the Couple-Gear. All of these companies and many others will be represented at Milwaukee from September 19 to 28 when the annual convention of fire chiefs will be in session. This year the exhibition of power-driven wagons and pumps and all other types of fire-





110-horsepower Notl tractor ready to pull its pumping engine to the fire

fighting apparatus will be vastly more complete than ever before.

The New York department has practically decided upon the general lines that should be followed with respect to the high-pressure hose wagons. Aside from the fact that they must be very speedy and comparatively light, the body specifications call for two 35-gallon chemical tanks in addition to the present equipment. Thus the wagons of this type could serve a double purpose. The most disastrous fires that ever destroyed a city started from a small blaze or at least could have been controlled in the vast majority of instances by a swift dose of chemical fluid at their inception. Of course in the case of a fire starting from a fierce explosion the matter would be different, but the number of

such conflagrations is small and of secondary consideration.

If the instant an alarm is struck an automobile wagon of supreme speed could be whirled to the scene of the blaze the chances are that the fire could be handled with trifling loss. A delay of five minutes might mean the difference between a chimney fire and a disaster. Therein lies the purpose of the chemical tanks in the hose wagons.

Seven more Webb wagons, identical in general lines with the three now in service, have been ordered and three more Couple-Gear trucks like the one at 31's house have been contracted for. These will be used for aerial ladders, etc.

Commissioner Johnson's plans for the wholesale additions to the present motor-propelled fire-fighting apparatus do not necessarily include standardizing any of the automobile apparatus at present in the department. The matter of standardization is being taken up by the board named by the commissioner and tests will be held to determine the best general types for standards. A new kind of apparatus is in contemplation which will be a sort of scout automobile chemical engine for the outlying districts.

One effect that will be noted in the elimination of the horse-drawn vehicles will be the lengthening of the aerial ladders and the increase in size and efficiency of the trucks used for that service.

Some of the best-informed men in the department favor automobile tractors upon which the fifth wheel of the present steam pumping engine can be placed. This would make it possible to disconnect the pump from the tractor in case of accident and substitute horses for the mechanical power. No gasoline pumping engines have answered the requirements of the department so far in the matter of volume of water thrown, but much effort is being made to perfect such a device.

Twenty-one new fire houses have been ordered by Commissioner Johnson and these will be equipped with motor apparatus. In addition to these automobile apparatus will be installed in a number of existing fire houses, thus doing away with horse equipment gradually.

Of the first 100 pieces to be purchased by the department it is likely that there will be twenty pumping engines or tractors drawing steam pumping engines, all of which, of course, will be motor-



The Foundry, a special feature of the Fire Department service section

hose wagons, scout chemicals and a few cars for the transportation of administrative heads.

The high-pressure zone is being extended and eventually will cover all the congested districts, thus widening the field of usefulness for the hose wagon equipped with a giant nozzle and capable of taking the streams from four or more plugs.

The main advantages to be found in automobile apparatus consist in their higher speed, which allows a wider radius of action, higher efficiency because of the increased power and speed and lowest cost. The records of the department show that the average up-keep and maintenance of a three-horse team and apparatus is about \$1,080 annually. This includes shoeing and feeding the horses and overhauling and repairing the apparatus.

A high-pressure hose wagon of corresponding type to the above would cost less than \$100 for gasoline, oil, grease and mechanical attention and repairs, including tires. Thus the taxpayers would save \$1,000 a year on the operation of each wagon that displaces three horses. In addition they gain augmented protection because of the speed of the wagons in getting to the scene of hostilities and the increased efficiency of the fire-fighting equipment itself.

Of course there would not be as much as \$1,000 difference between the cost of operating a tractor drawing a steam engine and a horse-drawn steamer, because the water in the boiler has to be kept hot all the time, no matter what the motive power of the apparatus. But even on that basis there is a sharp economy shown by the elimination of the horses that formerly pulled the steam pumps. It is likely that the saving would amount to \$700. It is easily figured that the department will save at least \$120,000 a year when the 150 pieces of motor-driven apparatus have been installed.

The men who are connected with the companies to which automobile engines and wagons have been assigned are enthusiastically in favor of them. The absence of horses from such fire houses is a welcome relief to the noses of the men and the lack of flies is certainly appreciated by the men who are obliged to sleep in daytime. No matter how much a man may love the horse he hates to clean him, and no matter how educated the sense of smell may be nobody to date has confessed to liking the strong ammoniacal odor inseparable from horses.

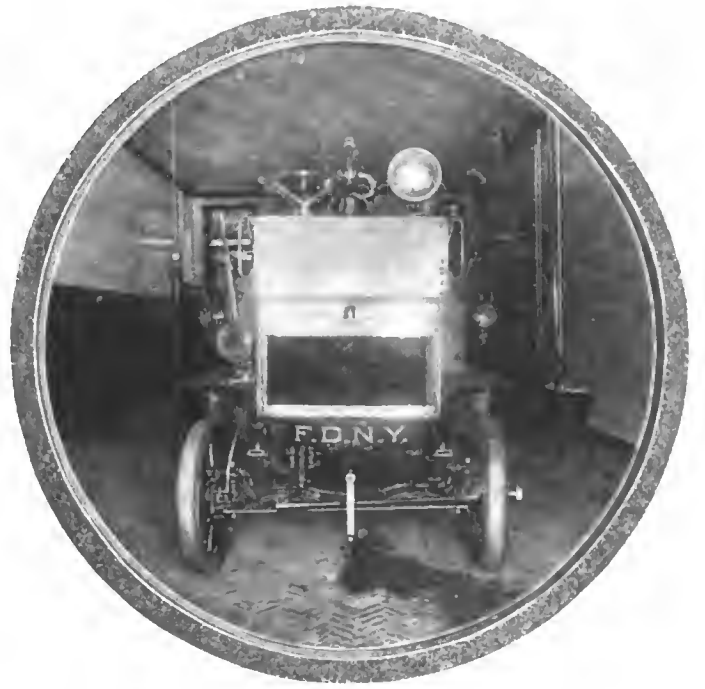

Knox hose wagon, a 50-horsepower truck assigned to Engine House 72

The streets of New York, particularly in the congested, high-pressure districts, are in fearful condition for fast operation and the commissioner has entered protest with the borough officials. The strain on automobile mechanism traversing some of the rough streets is almost impossible to sustain and is most unfair in the way of a test of efficiency. So far the various engines and other apparatus have stood up staunchly, but unless the streets are repaired or paved the usefulness of such apparatus will be reduced in a pitiful manner and much of the well-intended improvements and innovations of the commissioner will be nullified by the *laissez-faire* attitude of the department in charge of the work of keeping the city streets in good condition.



First class in the school for driver-mechanics conducted by the department



Showing the start of the five-mile handicap race (from behind)

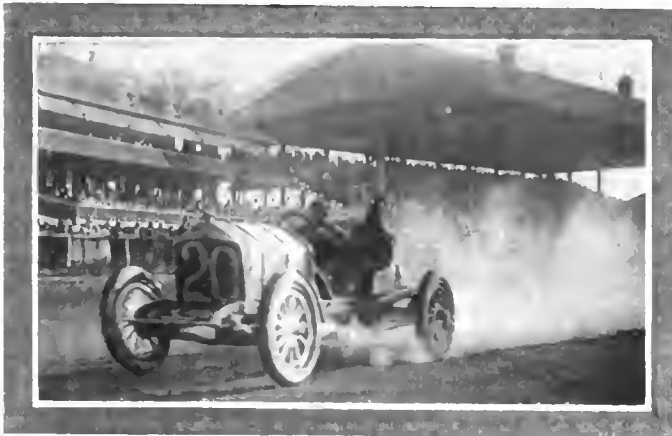

National, driven by Sheets, passing the grandstand



The winning E-M-F car finishing the first event on the first day



Mercer No. 22 on the homestretch in the 50-mile race (Monday)

# World's Records

## Blitzen Benz Sets

*During the two-day automobile meeting Burman in the giant Benz car established a circular dirt track. There was a great on Saturday. The fields in all the races except Saturday were wide, while on Monday they*

**N**EW MARKS were set for the one and two-mile distances on circular dirt tracks at the two-day automobile race meeting that came to a close on Labor Day at Brighton Beach. The Blitzen Benz, driven by Burman on Saturday, reduced the two-mile record to 1:37.89, knocking off about three seconds from the best previous time for the distance. On Labor Day the same car and driver clipped 1-10 of a second from the mile distance, making the circuit in 48.62 seconds.

The track was in better shape than ever before, especially on the final day, and with good weather two big crowds turned out to enjoy the sport. There were probably 15,000 paid admissions during both days. Only one accident happened and that was not serious. This incident came off in the final race on Labor Day, when Spencer Wishart, in his big Mercedes, attempted to catch the flying Mercer in the handicap race. The car blew a right rear tire at the club house turn and plunged through the fence overturning with the young millionaire. It was in the last lap of the race, which probably accounts for the lack of fatalities, for to the amazement of the big crowd, no sooner had the car capsized in the ditch than an ambulance dashed out on the track among the rushing contestants and galloped up to the prostrate Mercedes. Wishart certainly would have been no worse than second but for the accident.

Of the racing there is little to be said. On the first day the finishes were all tame and on the second they were all close. They were so tame on the first day that the spectators lost interest to a great extent save in the first heat for the Remy Bras-

### FIRST DAY'S SUMMARIES

No.	Car.	Driver.	Position.	Time.
<b>Five Miles, for Cars of 161-250 Cubic Inches</b>				
16	E-M-F	Tower	1	5:55.36
9	Paige-Detroit	Craig	2	
11	Penn "30"	Ainslie	3	
51	Jackson	McBride	4	
12	Lancia	Ferguson	5	
<b>Five Miles, for Cars of 251-300 Cubic Inches</b>				
22	Mercer	Hughes	1	5:22.56
2	Correja	Foster	2	
17	Schacht	Gray	3	
<b>Five Miles, for Cars of 301-450 Cubic Inches</b>				
20	National	Sheets	1	4:51.80
46	Benz	Disbrow	2	
15	Jackson	Cobe	3	
52	Jackson	Regan	4	
<b>Two Mile Time Trial Against Mark of 1:40.55 World's Record</b>				
1	Benz	Burman		1:37.89
<b>Five Miles, for Cars Under 600 Cubic Inches</b>				
20	National	Sheets	1	5:27.67
15	Jackson	Cobe	2	
<b>Three Miles Free-for-All, Flying Start, First Heat Remy Brassard</b>				
4	Benz	Burman	1	2:57.04
3	Mercedes	Disbrow	2	
8	Hotchkiss	Kilpatrick	3	
<b>Fifty Miles, for Cars Under 600 Cubic Inches for W. B. Trophy</b>				
14	Opel	Burman	1	50:07.13
22	Mercer	Hughes	2	
15	Jackson	Cobe		
20	National	Sheets		
<b>Five Miles Handicap</b>				
4	Benz (scratch)	Burman	1	5:25.25
22	Mercer	Hughes	2	
16	E-M-F	Tower	3	

Correja, Hotchkiss, Paige, Lancia, National, Regal, Jackson and Opel also ran.

# Fall at Brighton

## New Marks Sprinting

at Brighton Beach, which ended Labor Day, new level for the one and two-mile circuits of crowd present on Monday and a good one the handicaps were small and the finishes on were of the eyelash variety.

sard and trophy. In this event three entries from the Moross string constituted the field and the most carping critic could not wish for a prettier race or a more stirring finish. In fact all three cars led at one stage or another and a blanket could have covered them at the finish. It was highly artistic, particularly Disbrow's driving of the Mercedes representative of the string. The final heat was also a spectacular triumph with the result never in the least doubt but the winning margin was slight. The big crowd was somewhat astonished when it was announced that the Moross Mercedes was to be driven by Oldfield, but their fears were quieted when it was learned that the driver was not the redoubtable Barney, now under the official ban.

Close finishes were the order of the day in the final session. In fact, it seemed as if the "order" was followed a trifle too literally. In several of the races the winner lay off the pace and just nosed out the second horse in furious drives that aroused much enthusiasm. The first event was taken by an E-M-F, or rather the E-M-F which just galloped all the way and won going away. The Mercer took the second without much of a struggle and National 20 annexed the third class race. The same car also won the big class event in comfortable style. The first heat of the Brassard contest was won by the Benz in a nose finish with its stable mates, the Jenatzy Mercedes and the 200-horsepower Hotchkiss.

The 50-mile feature brought out a field of four cars including an Opel, Mercer, National and Jackson. The Opel set a fast pace for five miles when it was headed for a moment by the

### SECOND DAY'S SUMMARIES

No.	Car.	Driver	Position	Time
<b>Five Miles, for Cars of 161-230 Cubic Inches</b>				
16	E-M-F	Tower	1	5:45.13
9	Paige-Detroit	Craig	2	
11	Penn "30"	Ainslie	3	
12	Lancia	Ferguson	4	
<b>Mile Time Trial Against World's Record of 48.72</b>				
1	Benz	Burman		48:62
<b>Five Miles, for Cars of 231-300 Cubic Inches</b>				
22	Mercer	Hughes	1	5:35.10
17	Schacht	Gray	2	
<b>Five Miles, for Cars of 301-450 Cubic Inches</b>				
14	Opel	Burman	1	5:02.96
46	Benz	Oldfield	2	
20	National	Sheets	3	
<b>Final Heat Remy Brassard, Three Miles</b>				
4	Benz	Burman	1	2:50.90
3	Mercedes	Oldfield	2	
8	Hotchkiss	Kilpatrick	3	
<b>Ten Miles, for Cars Under 600 Cubic Inches</b>				
14	Opel	Burman	1	9:43.30
11	Mercedes	Wishart	2	
22	Mercer	Hughes	3	
20	National	Sheets		
<b>Five Miles Free-for-All Handicap</b>				
22	Mercer	Hughes	1	5:14.31
16	E-M-F	Tower	2	
20	National	Sheets	3	
Paige, Penn, Lancia, Hotchkiss, Mercedes, Regal and Benz also ran.				
<b>Fifty Miles, for Cars Under 600 Cubic Inches</b>				
22	Mercer	Hughes	1	49:56.06
11	Mercedes	Wishart	2	
20	National	Sheets	3	
14	Opel	Burman		



Hotchkiss No. 8 doing the clubhouse turn in Remy Brassard race



Some five hundred cars parked at Brighton Beach on Saturday



Burman in Benz breaking one-mile track record in 48.62 seconds



Opel (Burman) and Benz (Oldfield) in a close finish



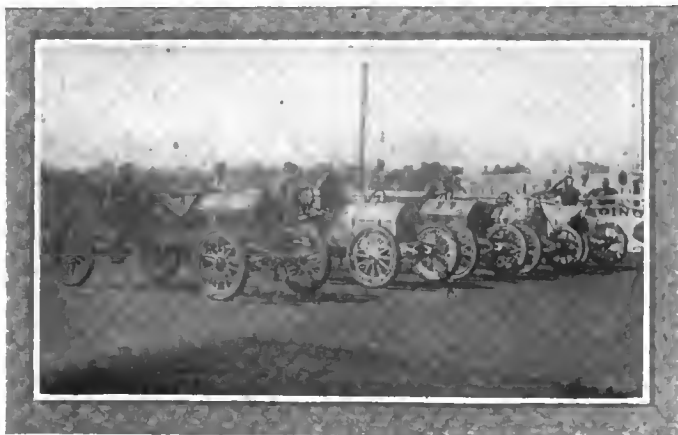

Jackson, Paige-Detroit, Penn "30," Lancia and E-M-F (winner) lined up for small car race

Mercer and then reassumed the lead clear to the wire. The National suffered tire trouble early and often and was afflicted with a sooty spark plug in the middle distance, losing eleven laps during the tire changes. The Jackson pursued a troubled course for half the distance and retired from what was announced to be carburetor troubles. The Opel ran steadily and quietly from start to finish, closely accompanied by the Mercer, until the forty-seventh mile, when a dangerous blow-out on the clubhouse turn caused the loss of over a lap. Hughes handled his car in masterly style and after limping around to the paddock made a wonderfully quick tire change and was out on the track again in pursuit of the curious looking German car. The Opel won eased up in 50:07.13, slightly less than 60 miles an hour.

The last race of the first day was the prettiest on the card. It was a free-for-all handicap and a Benz car from scratch proved the winner, getting up in time to defeat the Mercer and E-M-F in a wild drive.

The second day's card furnished a series of the most remarkable finishes ever seen in any automobile races. The E-M-F lay second and third for four and a half miles, taking the dust of the Paige-Detroit and part of the time trailing the Penn 30. But when the final run came along Tower moved up quickly and swung into the stretch on even terms with the pacemaker. From there to the wire it was a hair-raising struggle with the honors going to E-M-F.

In the second race it seemed impossible to make a contest with only the Mercer and Schacht entered, but Hughes in the Mercer proved the fallacy of such a supposition. The Schacht led for part of the distance or until the Scotch driver was ready to get into action and then there was nothing much to it but the Mercer.

The Opel showed its quality in the third class event by winning from a Benz and a National. Burman at the wheel of the winner was first at the wire rather easily by a very tight margin, with Oldfield in the Benz just far enough away to get second money. As has been recounted, the final heat of the Remy Brassard was another magnificent triumph of art and clever driving by all three of the Moross pilots.

The ten-mile event for big cars brought a field of four to the line, including the Opel, National, Mercer and the big Mercedes racer owned and driven by Spencer Wishart in the recent 500-mile sweepstakes at Indianapolis. The Opel made the pace all the way, but the Mercedes kept shooting at the leader on every turn only succumbing at the very end. The Mercer was a close third the National going out with a puncture on the first turn.

The fifty-mile race went to the Mercer, after the Mercedes had suffered its second blowout. The pursuit of the low-hung yellow automobile driven with supreme skill by Hughes, by the big-hooded gray racing car was extremely interesting. Hughes never took a chance and when he found that his rival had eliminated himself from first place, barring a broken axle or something of the sort, he finished the distance easing up and allowing the Mercedes to regain a lap.

The last race of the day and meet looked like a tragedy for a minute during the last lap of the free-for-all handicap. There was a big field on the track and the Mercer had gradually worked through the small fry and was out in front passing the stand on the last lap. Up the stretch was the E-M-F that had shot its bolt and directly behind the Michigan car came the National and the Wishart Mercedes. The National was going well for the first time during the day and Wishart was pushing the German car to the limit. The National was on the rail and when Wishart opened up at the wire the Mercedes shot ahead and took a long slant for the first turn, intending to displace the National and close the gap on the leader. Wishart made a quick rush for the turn, but was so close to the National after taking the rail position that the National was obliged to hold hard and shut off.

Suddenly the stands were electrified by the sound of a tire explosion and out of the cloud of dust the big gray car was seen to make a dive diagonally across the track. Clear to the pole the car shot with the driver doing manful work in an endeavor to hold it on the track. Just for a second it seemed as if he would succeed and then a cloud of fence rails and splintered posts told the tale of going through the fence.

The car tottered on the side of the ditch and then turned over, Wishart leaping out in safety. The extraordinary proceeding attendant the visit of the ambulance among a dozen racing automobiles has been told. Just why the driver did not take the regular road is one of those mysteries for which there is no explanation. At any rate he did not do so, but nobody was hurt. The meeting was a glittering success from the financial and artistic viewpoints and the public got a great big measure of interesting spectacles.

### Preparing for Chicago's Six-Day Run

CHICAGO, Sept. 3—The pathfinding trip for the Chicago Motor Club's reliability run was completed to-day when the Halladay scout car carrying John P. Dods of the Official *Automobile Blue Book* and his staff drove in from Grand Rapids, Mich.

Several changes have been made in the original route laid out, particularly on the second day. Instead of going from Indianapolis through Terre Haute and Vincennes to French Lick, stopping half of Sunday at the last-named place, then driving to Louisville in the afternoon, it has been decided to go south to Seymour via Franklin and Columbus, then west through Brownstown to Bedford, Salem, Pekin, Borden, New Albany to Louisville, where Sunday will be spent. The third day's run will be from Louisville to Cincinnati, the fourth day to Columbus, the fifth day to Detroit, the sixth day to Grand Rapids and the seventh home, a distance of approximately 1,400 miles.

The run will be a stock-car proposition and will be a grade 1 event with technical penalties and technical examinations to determine the winners. There will be two divisions, one for touring cars and the other for runabouts, while in addition there will be a team trophy and a fuel economy prize.



National (Sheets), Mercedes (Wishart) and Opel (Burman) in the fifty-mile race on Labor Day



# A Plethora of Valveless Ideas

## Differing Materially From Conventional Practice

*In the series of valveless motors illustrated in this motor one thing that will strike the reader is that they differ in many ways from what has already been done along this line. Who knows but what among the apparently impossible propositions that have been evolved in the last few years there resides the basic principle of an entirely practical, successful motor.*

THE man who said "There is nothing new under the sun" might have modified his ideas if he had lived in the twentieth century. There is no doubt that the proposition of evolving something new in the endeavor to create a motor that will do away with the poppet valve has given a good deal of food for thought to the inventively inclined.

### Martin Uses a Rotary Valve Consisting of a Split Ring

The objects of the invention shown in Fig. CC are to balance the valve carrier and construct a valve in such a manner as to avoid pressure thereon, and to provide a silent-working mechanism of simple construction for controlling the gases to and from the cylinders. (A) in Fig. CC represents a transverse section of a cylinder of the motor. The working cylinder A has two ports, B and B1, which first act as inlet ports and then as exhaust ports. C represents the valve casing, and the rotating valve shaft E is carried in the bearing D. F and G represent the inlet and exhaust passageways in the valve casing. H and H1 act as valve carriers. The split rings I are formed in the shape of tubes, and each has a gap at I1 between its edges, being open at both ends. The valve finds a seating at C1, and C2 is one of the passageways in the valve casing which place the valve in communication with the cylinders. The valve carrier H is formed with disc-shaped ends H2, which fit against the cylindrical interior of the valve casing, and are held in position by the valve covers D1. Each pair of these discs H2 is connected by a central portion or rod of reduced sectional area, which at its center is provided with a disc H forming the valve carrier. Around recesses H3 in the exterior of the valve carrier H are pinned the split rings or valves I, which by being placed in the recess H3 are properly balanced. This construction prevents pressure from getting inside the valve ring I and expanding against the valve seating. The valve carriers H have grooves cut in them. The intake and exhaust ports F and G are placed in the head of the cylinder,

### Oscillating Valve with Shuttle Cam of French Design

The principle involved in the design of the motor shown in Fig. CD is applicable to cylinders with the valves in double file, as well as in the single file form illustrated. The valve V acts as a distributor valve, controlling both inlet and exhaust ports by its reciprocating motion, which is effected by a shuttle cam C through the medium of a roller R carried by the oscillating foot F of the valve spindle. The motion may also be imparted by an adjustable bell crank with a hardened toe-piece in contact with and rocked by a cam of conventional form. During the reciprocating movement, excepting when subjected to the pressure of compression and explosion, the valve is relieved of contact by a coiled spring S interposed in the vertical shaft S1, the latter being split for that purpose. The shape of the valve V is shown in the plan view of a cylinder B in Fig. CD. The working cylinder A has a port P, and as the valve V reciprocates, the inlet and exhaust passageways are uncovered, placing the cylinder in communication with them.

### Ward Motor Has Sliding Block in the Cylinder Head

The method of controlling the gases in the motor designed by W. C. Ward is shown in Fig. CE. The cylinder wall is cast with a lug L1, which acts as a bearing to the upper end of the vertical shaft S, which is driven by suitable means from the crankshaft at half-speed thereof. The upper extremity of the shaft carries a cam-shaped disc A, with a specially grooved slot B cut therein, in which is engaged a roller C of the slide valve D. The valve proper is formed with exhaust ports E and F, and a transverse web G which has an enlarged foot to cover the cylinder port J during the time that the motor is compressing and exploding the gases. The cam A being rotated, the valve D will move to the left, which will place the port J of the cylinder into communication with the exhaust ports E and F, allowing the burned gases to find an exit through the passage K in the cylinder head, which, as will be seen, is amply provided with water-jacketing surfaces. The continued rotation of the cam A draws the valve D in the opposite direction (to the right); when the foot of the transverse web G passes over the port J, the latter will be placed in communication with the valve chest L and the induction manifold through the port N.

### A Combination of a Rotary and Poppet Valve

The section of the head of a cylinder shown in Fig. CF is the invention of W. McLeod, Coventry, England, and shows how a poppet valve has been combined with a rotary shutter valve in controlling the gases. As will be seen in Fig. CF, it consists of a single poppet valve of unusually large size which controls the opening of the exhaust and closing of the induction, and a rotary valve which controls the operations of closing the exhaust and opening of the intake. The valve setting, which is taken from the *Autocar*, is shown in Fig. CG. The rotary valve runs at half engine speed and has but one port, which is of slightly oblong shape. At the point where the exhaust opens the port of the rotary valve coincides with the exhaust passage, so that on the poppet valve A being depressed by the cam J there is a free exit for the burned gases. The cam J holds the poppet valve open while the rotary valve continues its revolution until the port is closed, thereby finishing the period of exhaust. Continuing its rotation, the intake port is placed in communication with the cylinder through the slot in the rotary valve and as the poppet valve has been held open all this time, this closes when the piston has started to ascend on the compression stroke. During the compression and working strokes of the piston, the poppet valve is held closed by the spring S, the rotary valve, however, continuing to rotate, so that by the time the piston has descended and is within 42 degrees of the bottom of its stroke, the poppet valve again opens, placing the port P in communication with the cylinder.

The rotary valve in this motor is entirely unaffected by the pressures in the cylinders, as during compression and explosion strokes it is covered by the poppet valve A. The poppet valve remains open twice as long as is the case in the ordinary arrangement and owing to its large diameter only a small lift is

necessary. The method of operating the valves can be seen by referring to Fig. CF. The shaft is caused to rotate either by means of a silent chain which is becoming the accepted form for this style of transmission, or by a vertical shaft driven by bevel gearing from the crankshaft. The shaft carries a series of cams J, and a wormwheel G. The operation of the cams is conventional and needs no explanation. The gear G meshes with the gearwheel Gr attached to the extremity of the shaft

port cut therein which is caused to register with the intake and exhaust passageways, being operated by means of three sets of bevel gearing. The shape of the motor casting is clearly shown in the longitudinal section of the motor, which is of the single-cylinder, four-cycle type.

**Hewitt Controls Tandem Cylinders by Piston Valves**

This invention relates to the method of working tandem dif-

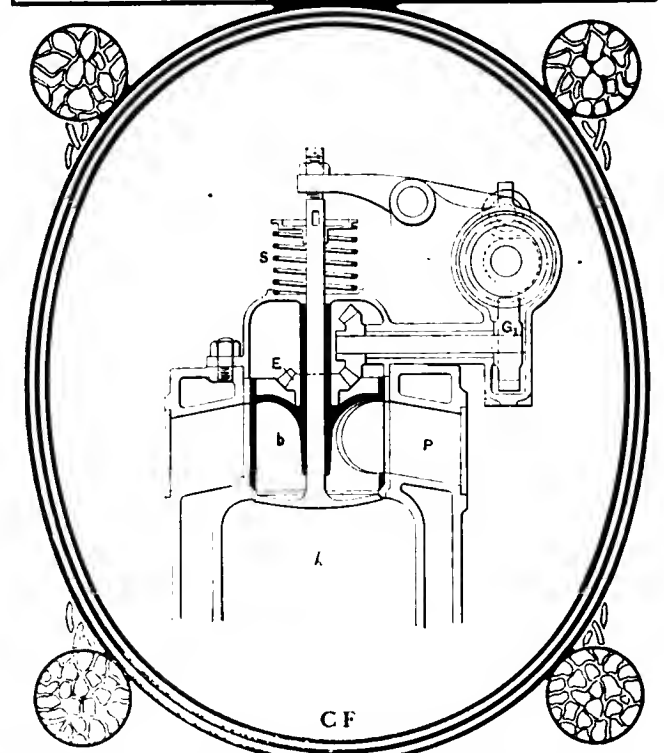
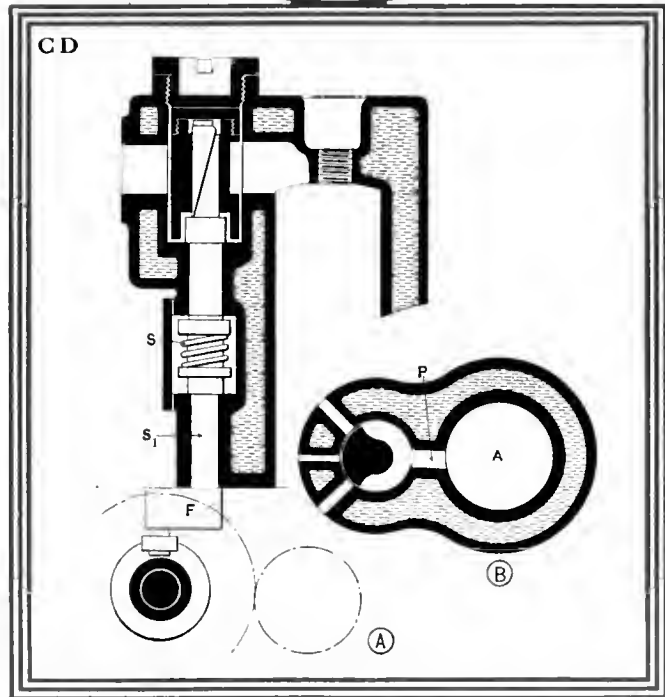
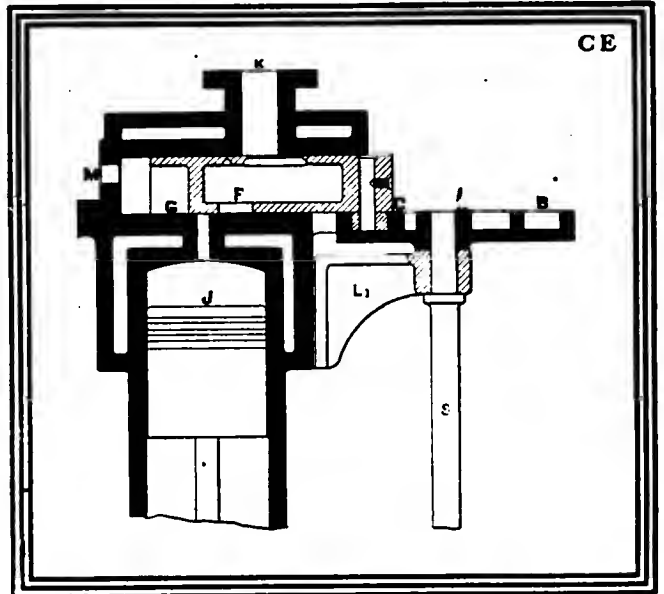
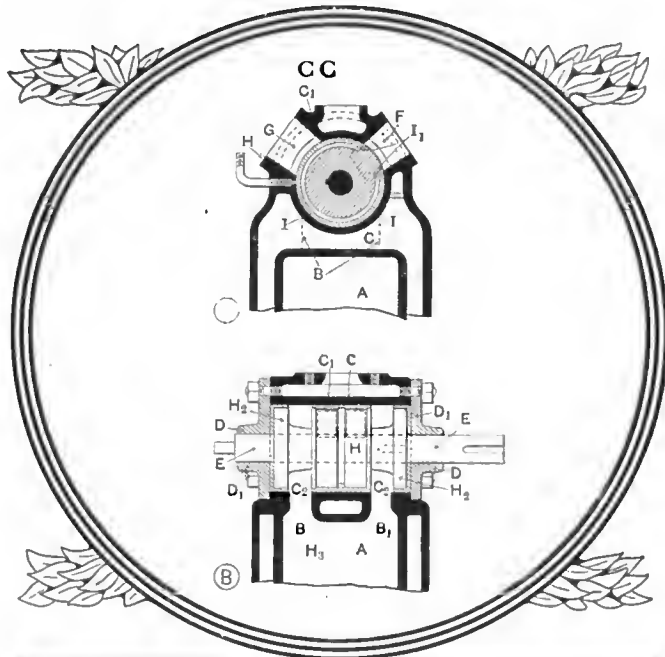

Fig. CC—Sectional views through the Martin Motor, showing the construction of the rotary valve  
 Fig. CD—Sectional transverse and plan views of a motor, with an oscillating shuttle cam valve

Fig. CE—Ward motor, showing the method of operating the slide valve in the cylinder head  
 Fig. CF—Combination of poppet and a rotary valve employed in the McLeod motor

F, which at its other extremity carries a bevel gear. This meshes with another gear E attached to the rotary valve B. The spindle of the poppet valve A passes through the hollow spindle of the rotary valve in the manner shown.

**Rotary Disc Valve of the Blood Motor**

This type of motor, shown in Fig. CJ, was described recently in THE AUTOMOBILE and consists of a rotary disc valve with a

ferential-cylinder, internal-combustion engine, which consists in cutting off the supply of mixture to either cylinder independently, or to both cylinders, and simultaneously opening such cylinder or cylinders to the atmosphere, so that three different powers can be obtained. The point of interest in valveless motors consists in the methods by which a tandem engine is controlled by piston valves working in cylinders open at their ends to the two engine cylinders. Fig. CI is a transverse sec-

tion through the induction valve of the motor; the two cylinders A and B are arranged one above the other in tandem form, the lower one being of larger diameter than the upper. The piston C is continued down and carries the lower piston B. The valves are double-ended pistons, are driven at half-speed from the crankshaft. They are set to uncover the ports alternately at either end of the piston valve, so that openings and closings to one cylinder are repeated half a revolution of the

so arranged that either or both valves can be opened, thus nullifying either or both cylinders. The sleeve K and the shaft P. are connected to a lever under the control of the driver.

Clegg Uses Elliptical Rings with Rotary Sleeve

The sleeve shown in Fig. CH is one from a motor designed by W. H. Clegg. The feature of this construction lies in the man-

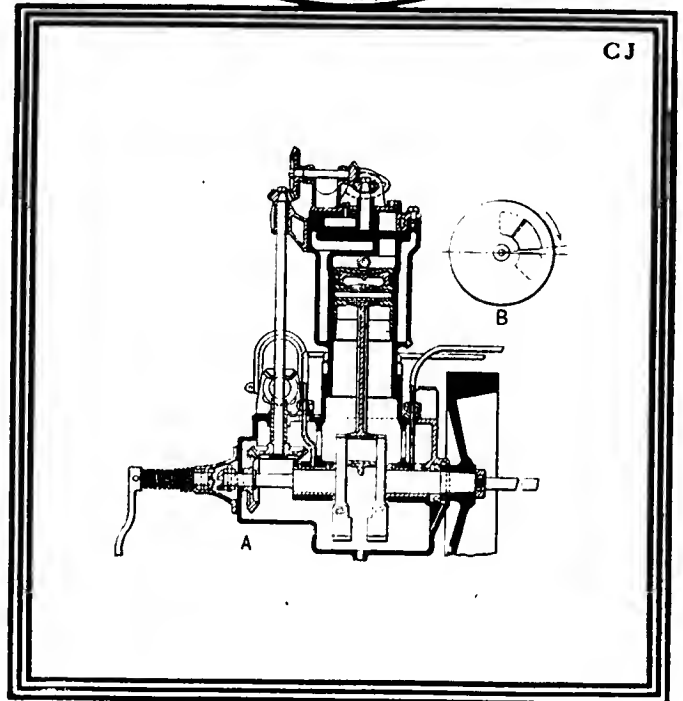
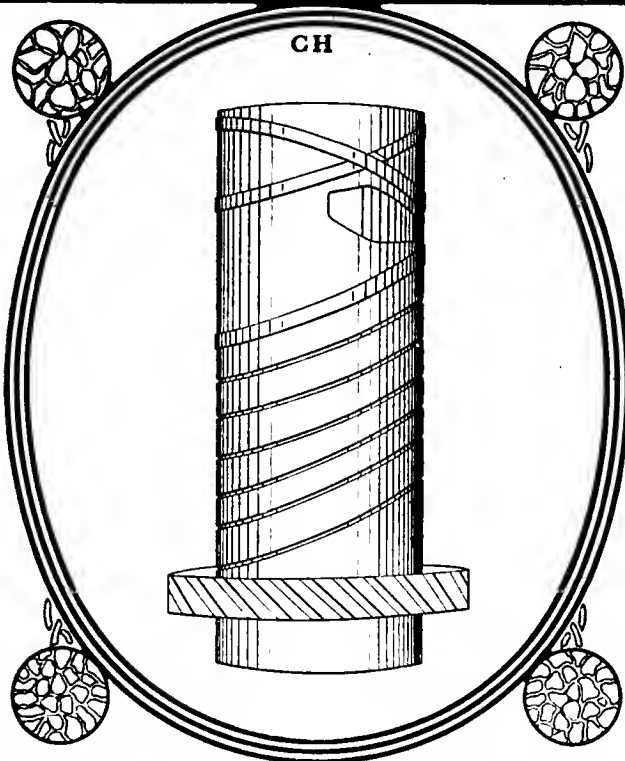
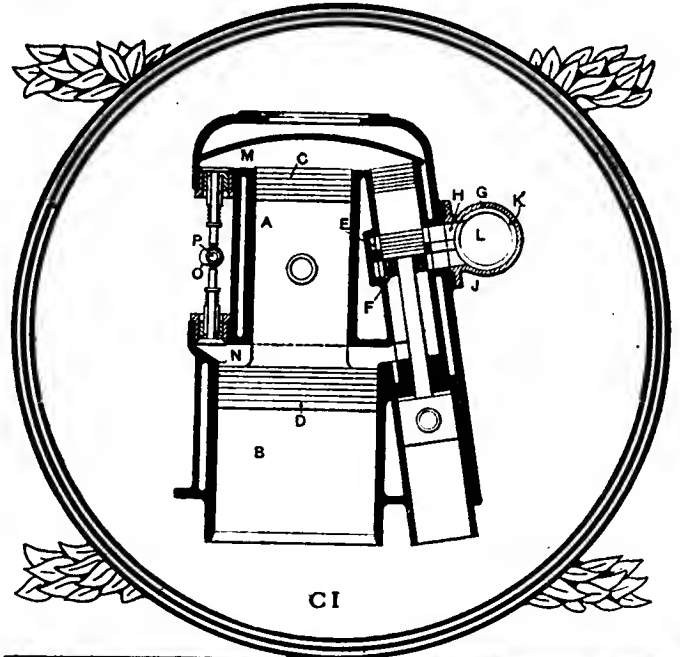
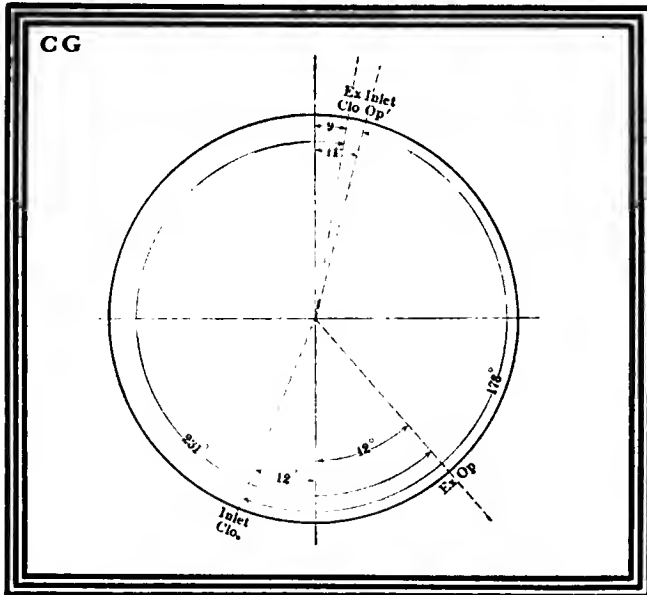

Fig. CG—Diagram of the timing obtained with the combination employed in the McLeod motor  
 Fig. CH—Appearance of the sleeve used in the Clegg motor, showing the elliptical expansion rings

Fig. CI—Section through the intake valve of the Hewitt motor, in which tandem cylinders are employed  
 Fig. CJ—Section through the Blood rotary disc-valve motor, showing method of operating the discs

valve crank afterwards in the other cylinder. Each cylinder has induction ports E and F, which open separately into the induction pipe G, forming valve ports H and G. A sleeve K, rotating within the induction pipe G, has a port L registering with the ports H and J in the induction pipe. The two air or relief valves M and N have springs which are strong enough to resist the suction during the induction stroke, and their stems terminate to meet the cams O on the shaft P, these cams being

ner in which the rings are cut and fitted; these are elliptical in shape. By making a simple attachment to an ordinary lathe, there is no difficulty in cutting the grooves in the sleeve or turning the piston rings in the manner shown. The idea of the inclined ring is to prevent uneven wear, and each ring comes into contact with a far larger surface of the cylinder wall than would be the case with the ordinary type of ring. It will be noticed that the grooves in the cylinder are cut elliptically.

# More Service for Ford Owners

## Long Island Building Open for Work

*Complete plant of the Ford Motor Company, dedicated to keeping the cars owned in territory contiguous and adjacent to New York in running order, has been finished and already a large force of men is employed in all departments. There is much room for expansion, and the present big building could be run up ten stories on the existing foundation if the necessities should require.*

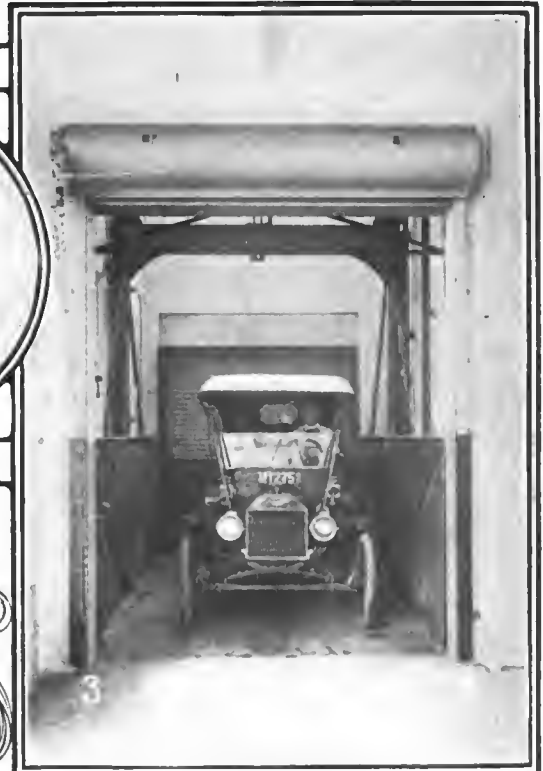

1—The new Ford service building at Honeywell street and Jackson avenue, Astoria, L. I.

2—The main offices located on the second floor are large and commodious.

3—Elevator connecting the various floors and one of the inlets from the railroad landing.

TEN thousand owners of Ford automobiles living in New York, New Jersey and Connecticut will be interested in learning that the magnificent new service department of that company practically has been completed and is prepared now to take up its work for them.

Good service is now regarded as one of the most important advantages to offer a prospective buyer and almost without exception the makers of automobiles have recognized the fact in some degree. The expression of this phase of marketing automobiles in New York takes various shapes and forms, the highest examples of which are shown in the new buildings of the Packard Motor Car Company, the Ford Motor Company, the White Company, Pierce-Arrow and several others.

Millions of dollars have been invested in these enterprises and only a real good start has been made so far. Judging from the past and present, the future holds out the certainty of numerous similar installations.

Service in its applied sense means keeping the car on the road. No matter how much a car may have cost it is worthless unless it will run, and the value of the "service department" is measured exactly by the amount it serves in time and expense in keeping the car running at high efficiency.

The Ford company has had a service department connected with its New York branch house for years, just as most of the selling companies in New York are equipped, and the new building simply means an attempt to furnish more and better service.

The lot, which is 250 by 265 feet, was purchased about two years ago and the building was commenced in March, 1910. The lot faces on Jackson avenue and Honeywell street, just where Astoria and Long Island City come together. Jackson avenue is the main artery of travel from the Queensboro bridge, and Honeywell street is only about half a mile from its eastern end.

**Plenty of Room for Expansion**

The present building occupies only a part of the lot and its construction has been accomplished with the idea of future additions. For instance, the walls are much thicker and more substantial than would be required for a building three stories high, and the roof as it stands to-day could be converted into another floor at small expense.

The present building measures 75 feet in width by 223 feet

in this part of the plant. The floor space of each of the four floors is 15,800 square feet or a total of 63,200 square feet in the four floors.

The main floor is divided into two parts, the front being cut off from the main room by a bulkhead at the second file of pillars. The interior of this room has been fitted up with massive but severely plain furnishings and decorations. The pillars are paneled with oak and the floor is tiled with enameled material. The front and both sides are occupied with wide show windows and the room will be used as a display place. The ceiling is 15 feet 9 inches high.

Back of the bulkhead is the garage, another giant room extending to the rear line of the building, rectangular and measuring 175 by 75 feet. At the side entrance of the building is stationed the timekeeper of the plant and the man re-



4—Long platform beside Ford plant from which seven cars can be unloaded at once



5—Showing the size of the storage room and garage on first floor of the building

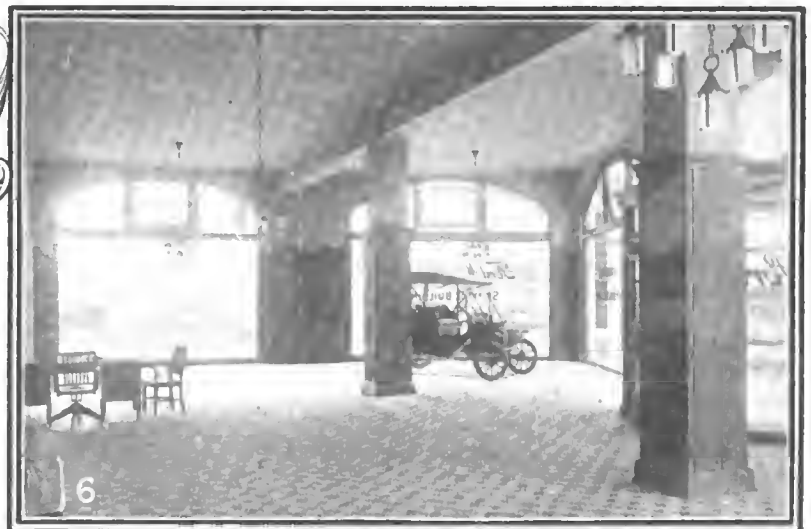

6—The show room, finished substantially in tile, concrete and hardwood panels

on Honeywell street and 195 feet on the inside of the lot. Its foundations are of rock and concrete and its walls 2 feet thick. The sub-basement, floored with concrete cement, is all thrown together in one vast room which is used for storage of completed cars. The ceiling of the basement is 12 feet 9 inches high and is connected with the outside and the other floors by a giant electric elevator. At the back end of the basement is the boiler room, which is separated from the rest of the structure by fire walls and is so isolated that one cannot reach it unless by going outside the building and entering from the rear.

Twenty massive pillars of reinforced concrete extend in double rank through the building longitudinally and are carried from sub-basement to roof. There is storage room for 300 cars

responsible for the comings and goings of men and material.

**How the Spare Parts Are Carried**

Ample room is afforded for over 200 cars on what would correspond to "live storage" in the ordinary garage. Like each of the other floors, this one has connection of course with the elevator, and at the rear of the building a spur of the Pennsylvania Railroad reaches across the whole structure and along a substantial freight platform so that seven cars can be loaded or unloaded at the same time. A door at the left side of the building also affords an inlet into the main building from the platform. The same may be said for a door through the center of the rear wall.





7—Where the actual work is done: the first table is for body repairs; second and third, engine assembly, and others, transmissions, axles, etc.

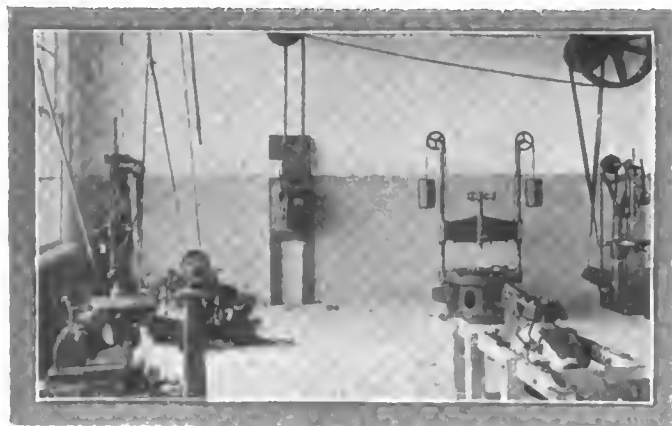

8—Machine tools with which the Ford service plant is equipped \*

The second floor, the ceiling of which is 14 feet 6 inches high, is one of the most interesting and important factors of the plant. In front and corresponding in size to the showroom on the ground floor is the office where fifteen persons are employed with records, correspondence and accounts. Back of the cross-bulkhead is the parts storage department. At the left side of the room is a series of adjustable bins of various sizes, all opening upon small aisles. These bins are numbered to correspond with the catalogue parts of the Ford automobile and there is one for each screw and washer, spring clip and block of cylinders, side member and ignition system as well as every other part contained in the automobile.

The card contains a statement of how many of the pieces have been placed in the bin and when any are withdrawn in filling orders, the fact is noted on the card before the clerk moves away from the bin.

There is a plain warning in each bin as to the minimum number of parts of the particular kind that it should always contain and when the stock has been reduced to that minimum level orders for replenishment are given. When a part is withdrawn, the clerk not only notes that fact, but he subtracts the number of parts he is taking from the number contained in the bin, showing the exact state of the stock at a glance.

An exact check can be thus kept on stock by comparing the original orders with the cards at stated periods.

There are thousands of these bins in this department, but very many of them contain the complete parts of former models. In fact, parts for the six-cylinder car made by the company several years ago are given considerable space although, of course, the emphasis is laid on the current model. In the bins there are parts for the assembly of fifty complete cars, from top to tires and from taillight to radiator.

The system of handling repairs is not widely different from that in use in other well-equipped plants. The car needing re-

pairs is brought in and inspected. Then the foreman issues an order on the storekeeper for certain parts by number. A copy of this order is kept by the foreman, the original goes to the superintendent and the triplicate is transmitted to the stockroom. The order is filled from the bins and a receipt is taken by the stockkeeper from the foreman.

The records of the superintendent are used as the basis of billing the work, and on a particular job the foreman's order



9—Where the body work is done: a dust-proof varnishing room partly finished is shown at the left



10—Runners used to elevate the front of a car make forward repair work easier

for parts, his bill for time used in his department and other expense bills are assembled under one charge number in the accounting department.

#### Keeping Track of Labor and Material

In the stockroom are complete parts for all models subsequent to 1904.

On the top floor is the repair department, painting and varnishing department and the department devoted to body work.

The body department is located in front and the repair department in the main division of the floor. In the body department, which is also equipped with a complete plant for painting and structural repairs, is a dust-proof varnishing room. This feature is not quite finished at present but will be in the course of a short time. The idea is to partition off space sufficient to handle two automobiles and by making the walls and interior partition dustproof with heavily woven cloth covering, to furnish a place where the final touches of body decoration will not be damaged by dust sticking to the drying varnish.

A fire door affords entrance to the repair department proper, which is one long room, 175 by 75 feet. On the left after passing the fire door is the place where the automobiles in various stages of repair are quartered. They stand along in a row from one end of the room to the other and at the time of the visit of a representative of THE AUTOMOBILE there were probably a

score of cars on the floor. The system of handling repairs is very simple. After the work is laid out and the exact character of the repairs to be made is established the car is dismantled as far as is necessary and the body is given a space in the row.

**Equipment Seems to Include Everything**

If there is to be some structural repair of the body, the damaged parts are removed to the first group of tables on the right side of the floor where vises and woodworking tools are arranged and where several men may work at once. If the motor is to be overhauled and repaired, it goes to the second group of tables and the transmissions are assigned to the third.

Just after passing the fire door there is a screened room at the right in which the power-driven machine tools are installed. These consist of lathes, drills, press, buffing and grinding tools, shaping and milling tools and constitute a battery of sufficient scope to handle any ordinary work.

There are many little refinements of action in the work performed at the Ford plant. One little device, the invention of the foreman of the repair department, is a pair of inclined runners upon which the car may be placed in such a way as to avoid the necessity of working in very close quarters. The runners raise first the front end of the car and then the rear and by using them access to the axles is made comparatively easy.

The building is as nearly fireproof as any similar building can

boilers and engine room referred to before being an auxiliary. The power plant is represented by a heavy feed wire, over which passes the electric force from the public station.

The sanitary accessories of the building are most complete and ample. Shower baths, comfort rooms and lavatories are distributed through the building.

**Railroad Facilities Are Ample**

Directly in the rear of the building is the spur track of the Pennsylvania Railroad and back of this switch are the main lines of the Long Island Railroad, all of which simplifies the problem of freight transportation.

It is the intention of the company to maintain a stock of cars at the plant which may be drawn upon in emergencies by dealers, but from the physical characteristics of the building as it stands there appears to be a vastly more significant future outlined.

As has been said, the present building can be increased to ten stories on its existing walls and foundations and the fact that only about one-third of the lot is occupied by the building makes future expansion among the probabilities.

If it is in the minds of the company to establish a vast assembling plant on Long Island to supply not only the contiguous territory but also the export requirements, the real estate and building now there would form a substantial nucleus for such an undertaking.

However, at present such a development seems far in the future and the immense building with all its modern fittings will be used to better Ford service. At this stage of progress the plant employs fifteen persons in the offices and seventy in the shop and repair departments. In the immediate future the latter item will be increased to 100 men and if the full capacity of the plant was filled the payroll of the shop force would contain at least 125 names. There are about a score working in the stockroom and a dozen are employed as floormen or demonstrators.



11—When the car is reversed it gives plenty of room to work under rear axle

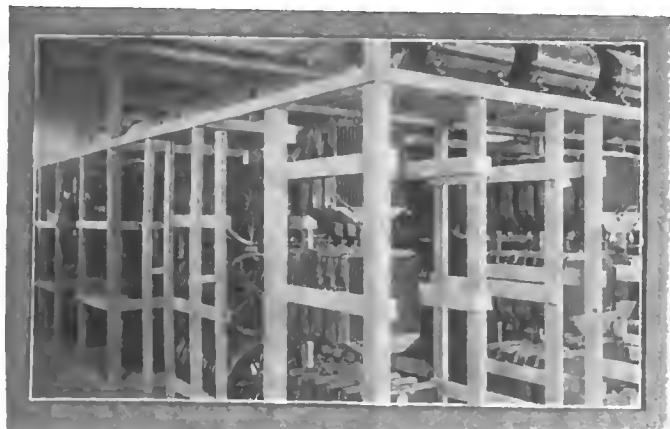

12—Some of the racks containing Ford parts, ready for any kind of a demand

be. Aside from a small amount of paneling and an occasional board here and there for a variety of purposes there is nothing combustible in the plant except the gasoline, oil and the cars themselves. In order to prevent fire danger the building is also equipped with a detailed system of sprinklers with fusible plugs that melt at a low temperature, thus insuring a deluge of water upon any point from which much heat radiates.

There is no big power plant in the Ford Service Building, the



13—Every part, nut and bolt going into the Ford cars is carefully listed and binned as shown here



14—An important part of any commercial enterprise is keeping track of what comes in and goes out

# Letters Answered and Discussed

## Dressing for Mohair Tops

EDITOR THE AUTOMOBILE:

[2,805]—Would you be kind enough to tell me if you know of any kind of dressing for mohair tops? I would esteem it a favor if you would give this your attention at an early date. F. R. FRIBLEY.

Bourbon, Ind.

Manufacturers of mohair goods and others acquainted with their wearing qualities, etc., advise the use of plain soap and water as a medium for keeping the mohair top in proper condition.

When the top becomes dirty and takes on a "frowzy" appearance brush very briskly with a stiff broom, or wash thoroughly with a solution of castile soap and soft water. Apply the solution with a wool sponge and dry off thoroughly. This is said to be the only safe method of treating a double-texture mohair top with a rubber interlining. The application of oil of any kind, of gasoline or any cleaning preparation is very detrimental to the rubber interlining.

Plain soap and water and the whisk broom are the reliable cleaning and preserving mediums of all mohair fabrics.

## Marking the Flywheel

EDITOR THE AUTOMOBILE:

[2,806]—As I am about to take down my engine to overhaul and clean it, I wish to be sure that I get the timing correct when replacing the valve mechanism. As the engine is at present, the timing is correct, and I have no desire to make any changes in that direction. I am aware that there is a method of marking the flywheel, but do not know exactly how to go about it. Would you kindly give me directions as to how to proceed? AMATEUR.

St. Paul, Minn.

The marks placed on the flywheel indicate the upper and lower dead centers.

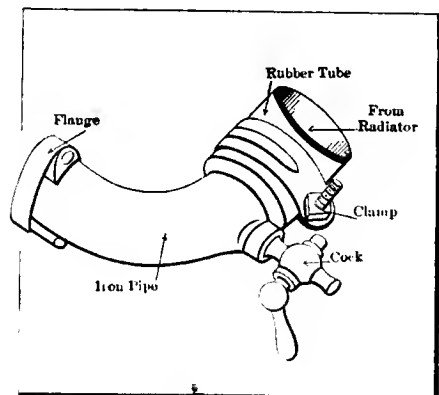

Fig. 1—Showing fitting with drain cock on radiator connection

the position of opening for both the inlet and exhaust valves and of closing for each valve. A piece of sheet brass is cut into the form shown in Fig. 3 and used as an indicator, or a mark is put on the engine base, which fulfills the same office. Chisel marks are then placed on the flywheel, and the initials of the operation indicate what is taking place when the mark registers with the indicator, as, for instance, in the illustration I E. O. indicates that the exhaust valve of cylinder number one has just started to open. In the case of several operations taking place at the same time, such as the exhaust for cylinders one and three, opening at the same relative position of the flywheel, the lettering would be 1-3 E. O.

## Keep It "Right Side Up"

EDITOR THE AUTOMOBILE:

[2,807]—Being a subscriber to your journal, I take the liberty to make a query, which I hope to see in an early issue of THE AUTOMOBILE. Would a motor lose any power if the engine were turned upside down so that the pistons exerted their power in an upward direction instead of downward? In this case the crankcase would, of course, be above the cylinders. The lubrication is considered to be perfect. A SUBSCRIBER.

Tiffin, Ohio.

If the lubrication were taken care of the engine would run. After the engine was stopped a pool of oil would probably collect in the cylinder head. We advise running the engine right side up.

## Soldering Aluminum

EDITOR THE AUTOMOBILE:

[2,808]—Kindly give me a receipt for soldering the aluminum base of an automobile. I would like to know where I can buy the special solder or flux necessary for this class of work. CHARLES DEAN.

Queen Anne, Md.

The soldering of aluminum has not as yet been perfected, although fairly satisfactory results have been obtained. Repairs made by the oxy-acetylene and electric welding processes, however, are highly satisfactory. A receipt which has been used to advantage in Germany is as follows: Tin, 80 per cent., and zinc, 20 per cent. The flux consists of 80 parts of stearic acid, 10 parts chloride of zinc and 10 parts of chloride of tin. A solid nickel soldering iron should be used, so as not to discolor the metal.

## Fitting Drain Cock

EDITOR THE AUTOMOBILE:

[2,809]—There is no drain cock on the bottom of the radiator of my automobile. Would you kindly tell me how to install one in such a position that it would be possible to drain all the water off in case I wished to store the machine for any length of time? Any information you could give me on the subject would be greatly appreciated. R. S. STEWART.

Tuckahoe, N. Y.

Where the radiator is connected to a pipe by means of a rubber tube, as is usually the case, a fitting such as that

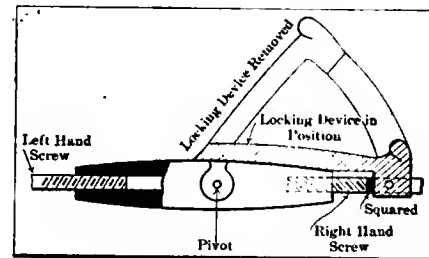

Fig. 2—Illustrating a method used by a subscriber in locking the brake adjustment

shown in Fig. 1 may be purchased, which will have a boss into which a plug or a cock may be screwed, as shown in the illustration.

## Locking Brake Adjustment

EDITOR THE AUTOMOBILE:

[2,810]—The sketch I am sending herewith (Fig. 2) illustrates a locking device which I have installed on the brake rod of my car. I think it is superior to the usual method of fastening by lock nuts. The lock is held in the turnbuckle by means of a pivot, about which it is free to turn. When in position, as shown, it is held by a pin which passes through the squared rod. E. F. S.

Garden City, N. Y.

## Desires Names of Cars

EDITOR THE AUTOMOBILE:

[2,811]—Do you know of any cars being made with planetary transmission, three speeds forward and one backing speed? I would greatly appreciate the names of these cars if you would give them to me at an early date. J. W. MELTON.

Richmond, Va.

We have no list of cars using the type of transmission you describe.

### Screen in Intake Line

Editor THE AUTOMOBILE:

[2,812]—I am using a very poor grade of gasoline and find great trouble in completely vaporizing it, especially at low speeds. I have been advised to put a screen in the intake manifold. Would you please tell me how it is done?

CHARLES BEECHAM.

Wellston, O.

It cannot be recommended as highly advisable to place a screen in the intake manifold. The method of inserting is shown in Fig. 4. An indentation is made in each of the two joining flanges, into which the flange which holds the screen is fitted.

### An Unexpected Kick

Editor THE AUTOMOBILE:

[2,813]—After having stopped my motor for a few moments I found it necessary to start it again, so I proceeded to crank

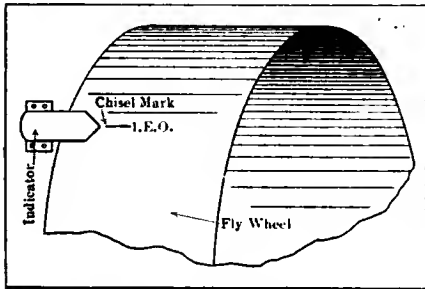

Fig. 3—Method of marking the flywheels of a motor so as to replace timing mechanism properly

in the usual manner, when suddenly the crank was jerked from my hand and I narrowly escaped painful injury. This is the first time the motor has ever kicked back while being cranked and I would be much obliged if you could give any causes to which it may be due.

J. F. S.

Greenlawn, N. Y.

The fact that the motor was cranked right after having been stopped, taken in connection with the probability that you have had experience enough to retard the spark before cranking the motor, tends to show that the cause of your trouble was an overheated cylinder. The overheating was doubtless due to carbon deposits (which may be removed by using a good decarbonizer) or to a projection in the cylinder.

### Opinions of an Outsider

Editor THE AUTOMOBILE:

[2,814]—I notice a good deal of discussion in the automobile trade magazines lately in regard to "what is the matter with the automobile trade." It seems that the sales are not what they are expected to be or what they should be. A number of reasons are advanced to account for the conditions, but there are some reasons that are apparent to a person "on the outside" that I have never

seen mentioned. I refer to the lack of courtesy and of selling ability in the agencies and branch houses.

It makes no difference how much a car is advertised in the magazines and newspapers if the agencies do not have men with the ability and tact to "close the deal" when the advertisements bring in the "prospect," the advertising does little good. If you will go around to almost any agency or branch and pretend you want to buy a car, you will find that the salesmen are, as a rule, young men who know considerably more about something else than they do about selling automobiles, and questions about details are generally answered evasively (through ignorance), or pertyly.

If as much selling ability (to the ultimate consumer) were used in the automobile industry as is used in selling typewriters, adding machines, the cash register, and many other lines of industry, there would not be so much "what is the matter with the automobile trade" discussed in the trade papers. The market for motor vehicles has hardly been entered yet compared to what it will be when manufacturers begin to sell the public what the public needs instead of what they think the public wants, and back their product up by salesmen who can sell the goods. It seems that the extraordinary demand a few years ago gave the manufacturers and dealers an inflated opinion of themselves and they have not recovered from it yet.

Some recent articles in the various automobile trade papers prompted me to write this to give you the views of one who is not connected with the automobile trade, but is interested in the progress of the automobile.

J. H. MILLS, JR.

Fort Worth, Tex.

### A Leaky Needle Valve

Editor THE AUTOMOBILE:

[2,815]—If you can give me any advice that will help me out of my difficulty I should be very grateful. My car ran very satisfactorily up to a short time ago when it suddenly became very balky on low speeds. The exhaust would emit great quantities of grey smoke and the engine would heat up greatly and then stop. If the motor was run at high speed it would smoke in the same manner and heat up but not to such a large extent as in running up a hill, for instance. I have adjusted the carbureter according to the directions of the maker but that does not seem to overcome the difficulty at all and I am sure that there must be a derangement somewhere.

JOHN EDWARDS.

Scranton, Pa.

The trouble is evidently one of too much gasoline. There might be some particle of foreign matter in the needle valve

which holds the same open, or the float may leak if it is hollow. Examine the valve and grind if necessary.

### Exhausts Batteries Rapidly

Editor THE AUTOMOBILE:

[2,816]—I have been greatly interested in reading about the troubles of car owners and your answers to them and would like to make an inquiry. I have a small car and for some reason my batteries are continually drained out, although two experts have gone over the wiring and say they see nothing wrong in it. I had a switch put in between the batteries and the timer so that when running on the magneto the batteries could be cut off entirely.

Last year I used about ten sets of batteries and this year have already used about six. Each set consisted of four batteries. I have been very careful not to run on the dry batteries, but have switched over to the magneto as soon as the engine is cranked. I would appreciate your opinion concerning the cause of the trouble.

H. G. VANDEVENTER

Mount Sterling, Ill.

It is very difficult to determine wiring trouble when it cannot be inspected. The indications are that there is a short circuit which might be constant or take place under certain running conditions, or the batteries may be in such a place that they chafe together causing their insulation to wear so that there is a slight contact between them after they have been used for a time. Another source of trouble may be the switch which you have inserted in the line. A switch is very apt to be connected up in such a way that current is allowed to pass through and hence cause the short circuit.

### Fitting A Magneto

Editor THE AUTOMOBILE:

[2,817]—I am desirous of fitting a magneto to my car which at the present moment has only coil ignition. Would it be advisable to buy a second-hand magneto?

Chicago, Ill.

A. B. S.

It is risky to buy second-hand magnetos as there is no "come back" if anything goes wrong.

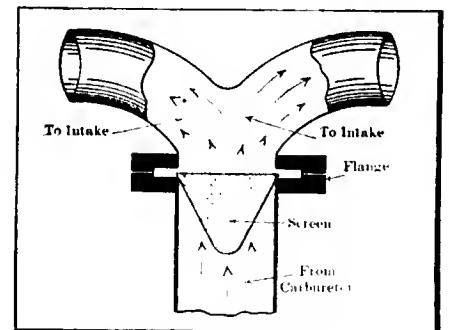

Fig. 4—Showing indentation in flanges so as to form a place for the supporting flange of the screen in the intake manifold

# My 1912 Automobile

## Some Conceptions of What the Ideal Car Should Be

The invitation to our subscribers to describe their ideal 1912 car has struck a popular chord. The responses show a wide appreciation of the salient points of car design and a knowledge of the points which tend to reliability and comfort. THE AUTOMOBILE hereby continues the invitation to its readers to mail in their conception of the features which should be embodied in next year's car. The information given should include such points as:

Horsepower	Clutch	Tire sizes	Equipment
Bore	Gearset	Rear Axle	Cylinder type
Stroke	Drive	Front axle	No. of cylinders
Ignition	Springs	Control parts	Cylinders, how cast
Lubrication	Wheelbase	Body features	Price
Carburation			

In addition to giving these details the reasons for your points of selection should be stated concisely and clearly.

As a benefit in the matter of comparison some details of the average cars for 1911 are given below.

Each communication must be legibly written on one side of the paper only; it must be properly signed with the writer's full name and address, and if the writer does not wish his own name to appear in print he may request the use of any nom de plume.

Any reader desiring to make line drawings, showing details of his ideas of his car or some of its parts, is requested to do so.

Editor THE AUTOMOBILE.

### DETAILS OF AVERAGE 1911 CARS WHICH WILL ENABLE READERS TO MAKE COMPARISONS IN DISCUSSING 1912 MODELS

	\$1,000 and there- abouts	\$1,500 and there- abouts	\$2,500 and there- abouts	\$4,000 and there- abouts
Horsepower	20.5	29.525	35	43.66
Bore	3.98 inches	4.19 inches	4.40 inches	4.875 inches
Stroke	4.12 inches	4.64 inches	4.98 inches	5.39 inches
Wheelbase	100 inches	114 inches	119 inches	124 inches
Front tires	31.4 x 3.3	33.1 x 3.8	35 x 4	35.7 x 4.27
Rear tires	31.4 x 3.3	33.1 x 3.8	35 x 4.1	36.7 x 4.55
Number of cylinders	Four	Four	Four	Four
Cylinder type	L-Head	L-Head	L-Head	T-Head
Cylinders cast	Pairs	Pairs	Pairs	Pairs
Ignition	Dual	Dual	Dual	Dual
Clutch	Disc	Multiple disc	Cone	Multiple disc

### Wants Conservative Design

EDITOR THE AUTOMOBILE:

Having driven and cared for several moderate-priced cars in the past few years, and having thereby gained some insight concerning their defects and good points, I herewith submit my idea of a car that would appeal to the owner-driver, of moderate income, and could be sold at about \$1,200.

First, considering the power plant, the motor should have four cylinders, with the cylinders cast singly, if possible, or if not, in pairs, but never en bloc, as accessibility is of prime importance to the owner who cares for his own car. Another objection to the en bloc type of casting is the limited amount of bearing surface for the crankshaft. The bore of the motor should be 4 inches and the stroke 5 or 5 1/4 inches, the long-stroke motor permitting greater power at slow engine speeds, thereby reducing gear changing in congested sections and in hill climbing. There are practically no

long-stroke motors used in any of the moderate-priced cars, the manufacturers evidently not wishing to assume the expense of designing new tools and fixtures to replace their regular models, in which the stroke in very few instances exceeds the bore more than 1-2 inch. The valves should all be on one side, being of slightly larger diameter than at present and given ample lift to develop the full power of the motor. Each valve spring and push rod should have an easily detachable aluminum casing of cylindrical shape, to protect valves from dust and deaden the noise.

Ignition should be by storage-battery and generator, with one of the systems of spark distributor now on the market, and this equipment would also take care of the lighting of the car and would not be any more expensive than the combined cost of the magneto, coil and gas tank. The dynamo would, of course, keep the storage battery always charged to its capacity, thereby making for long life for the battery. The motor should be water-cooled by the

thermo-syphon system, the inlet and outlet manifolds being made slightly larger than at present to insure perfect circulation. The radiator should be large enough to perform what is expected of it easily. As nothing adds to or detracts from the appearance of a car so much as the style of the radiator, care should be taken to make this of as neat a design as possible, preferably square tube.

The motor should have a self-starting device, as no car is complete that obliges the operator to leave his seat to start the engine. The system by which gasoline is pumped to the cylinders and the engine started by turning on the switch offers the simplest and least expensive way to obtain this result. The motor should be fastened to the frame at three points, in such position that it is entirely under the hood, so that any cylinder may be removed or any adjustments made without interfering with the dash or body of the car.

The transmission should be by sliding gears, selectively controlled, the gearcase being mounted on the rear axle assembly, while the control levers are in the center and the steering wheel on the left-hand side. There should be three forward speeds and one reverse; the reverse should be at least as fast as the lowest forward speed. In this day of flexible motors it is easily possible to run a car backward slowly enough, even if many of the reverse speeds were double what they are at present. The reasons for the left-hand steering wheel are so obvious that I will not dwell upon them. The steering gear connections should be so made that, even if worn excessively, it will be impossible for the ball joints to drop from their sockets. The front axle should be of the I-beam type. The frame should be double-dropped, as 10-12 inches road clearance is quite sufficient, as the low center of gravity obtained by the dropped frame is particularly desirable, since it eliminates skidding to a large extent, making it practically impossible for the car to "turn turtle."

Wheels should be strongly made, with Q. D. rims, and tires 36 by 4 inches all around. Springs should be semi-elliptic in front, three-quarter elliptic in rear, with shock absorbers included in the design so proportioned as to work in harmony with the springs. By this means much could be added to the comfort of the passengers. This would be appreciated greatly, as at present most of the cars of moderate weight are notoriously rough-riding when



they are used on other than smooth roads.

The wheelbase should be about 112 inches and the body designed with a view to comfort, the backs of the seats being high enough to insure this quality. Not a few manufacturers, desiring to obtain a low, rakish, straight-line effect, have lowered the backs of the seats so that touring in these cars is always accompanied by weariness. Comfort and easy-riding qualities are almost as important as mechanical perfection, while appearance should be subordinate to both, for it is easily possible to design a good easy-riding car to look as well as some of the bone-shaking creations designed to afford a racy appearance.

In almost all five-passenger cars of 110-inch wheelbase or more the front seat is crowded close to the dash, while quite a lot of room goes to waste in the tonneau, between the rear seat and the back of the front seat. This space could be utilized to good advantage by slightly lengthening the space allotted to the front compartment. By thickening the back of the front seat slightly, a compartment could be made to accommodate the extra shoe, there being a hinged cover over this compartment. The body should have doors in front, and these doors should be readily removable.

For a moderate-weight car the semi-floating type of rear axle is quite efficient, the full-floating type not offering sufficient improvement to warrant the extra expense. The gasoline tank should be sufficiently above the carburetor to insure perfect feeding when climbing steep hills. The carburetor should be the best that money can buy. No manufacturer should equip his car with a cheap carburetor, for even the highest priced and most efficient carburetors are relatively inexpensive, and the difference in price between a good carburetor and a poor one does not atone in the slightest way for the action of the motor equipped with the latter, when compared with how it would act when equipped with the former. No motor is better than its carburetor.

The weight of such a car as I have described ought not to exceed 2,800 pounds, and by liberally using vanadium steel and aluminum fittings where possible, could probably be kept down close to 2,600 pounds. All exposed bright parts, including all lamps, wind-shield, etc., should be enameled. The owner-driver who cares for his own car does not want to spend half his time polishing brass.

There should be no traps of any kind on the running boards, but a compartment having doors should be built integral with the back of the rear seat. In this compartment would be places for luggage, shelves for tools (each tool having its individual place) and room for storage battery, thus permitting the entire space under the front seat to be used for gasoline tank.

In summing up, the main points for improvement are longer stroke motors, more

accessible motors; easier-riding cars, secured by larger wheels, and properly designed springs and shock absorbers rather than excessive weight; more comfortable seats; more room for driver; higher grade carburetors; self-starting devices, and compartments to carry all accessories, thus eliminating all traps from the running boards. In conclusion I would state that all manufacturers should design their own tops and windshields to especially conform to the particular model, and always fix their price to include same in equipment of car.

Red Lion, Del.

A. H. SILVER.

## Idea of Popular All-Around Car

Editor THE AUTOMOBILE:

In your issue of the 24th inst. you invite contributions from your readers as to their conception of what the 1912 car should be. I am only a car owner who drives his own car, but I have been a student of the automobile industry from the beginning, and I believe the description I give below is of a car that would prove universally popular and would give excellent service under practically all road conditions.

The motor should be six-cylinder, 4-inch bore and 6-inch stroke, cast in pairs, with open water jackets and bolted together, giving an en bloc effect, but giving the benefit of separate castings; cylinders should be T-heads, all valves enclosed; flywheel and fan combined; the pumps and magneto should be mounted on a cross-shaft at the front of the engine, allowing ample room to get to crankshafts through side plates on crankcase. Engine base and case should be cast with web so as to abolish the mud pan. The engine bearings should be four in number and of large ball-bearing type. The engine thus described will be practically 40 horsepower under S.A.E. rating, but would no doubt really develop 50 horsepower under brake test, and would be amply powerful.

The ignition should be double. There is really no virtue in dual ignition. If the magneto is all right the car can be cranked on the magneto; if the magneto should have something wrong with breaker box mechanism the battery is also out of use. The oiling system should be crankcase circulating, with sight feed on dash and with a glass float gauge on crankcase.

The carburetor should be constructed so as to have a gasoline adjustment on the dash. The clutch should be multiple-disc with not less than 51 discs, and run in oil.

The gearset should be carried amidships, or might be installed as a unit with the clutch, or the fan might be of the conventional type, but shaft-driven, and the engine, clutch and gearset installed as a unit. The gearset should be four-speed, direct on third.

Springs, semi-elliptic in front, 2 x 40; rear three-quarter elliptic, and 2 1-2 x 45 inches.

Shaft-drive with two universal joints and tension rod, should be nearly straight-line drive.

Wheel base, 116 inches, which will give ample room in body for a four-passenger car. The frame should be pressed steel, double drop and inswept at front to permit of turning in the average street.

The steering should be of the irreversible type, with large steering wheel; connections all above front axle. The radiator should be of real honeycomb type and should be hung from trunnions on the side frames.

Tire sizes should be 36 x 5 all around, and should be on demountable quick-detachable rims.

Front axle should be drop-forged I-beam with integral spring perches; the rear axle should be full floating and wheels bolted to brake drums.

Spark and throttle control should be on top of steering wheel, and both moved upwards for advance. Also should be foot accelerator. Should be double brakes on large drum 17 x 2-1-2, internal and external, both equalized; foot pedal for service brake, with cam arrangement so that farther depression will apply emergency brake also, thus doing away with emergency lever. A patent has been allowed on a practically automatic gear-shifting arrangement that is destined to revolutionize gear shifting on pleasure cars. This will do away with the side shifting lever, transferring its duties to the automatic arrangement, allowing the steering wheel to be continued on the right side of car and allowing free entry from both sides of the car. The clutch pedal to be the left-hand pedal, which follows the almost universal practice.

This car should be built to weigh not exceeding 2,600 pounds. The body should be of fore-door type, with ventilators, front seats divided purposely to prevent more than two persons on the front seat. A pocket could be inserted in the division between the seats and every advantage taken to have the car convenient and comfortable. The upholstery should be the smooth finish because it lasts twice as long as tufted, though not quite so comfortable.

Equipment should be absolutely complete, self-starter, electric lights, top, top boot, windshield, hand horn, cut-out, license hangers; robe and foot rails, magneto, shock absorbers, bumper, tools, some form of inflating tires, speedometer, demountable Q. D. rims, one extra rim, tire hangers and trunk rack.

If one of the reputable manufacturers would undertake to put this car out with a guarantee for life of car, in my opinion they could make a handsome profit at a price of \$2,500 and would get orders for the entire output within sixty days from their announcement, but it would be folly for any of the newer and less known manufacturers to undertake its production.

ROBT. N. HUGHES.

Atlanta, Ga.

# Little Bits of Motor Wisdom

## Pertinent Pointers for Repairman and Driver

*A series of short stories that will tend to keep the automobilist in touch with matters mechanical and otherwise, covering a field of information that although usually well tilled, needs frequent and careful cultivation to produce the greatest results.*

**WHEN USING ROLLER BEARINGS—** In the effort to get away from sliding contact and its consequent loss of energy in friction one of the modern methods which has found favor is the use of roller bearings. Instead of the metal sliding over a plain metallic face it rolls over a series of small steel cylinders which are arranged as shown in Fig. 1. They are free to turn about their own axis so that the amount of bearing surface is very much reduced, being resolved down to a series of lines. The rollers are of course kept out of contact with each other as, if allowed to touch, their tendency would be to turn each other in opposite directions instead of in the same direction as they would do if performing their ordinary function.

An interesting feature about this type of bearing is the fact that the bearing surface instead of being a plane as is usual in any sort of bearing, consists instead, of a series of lines which are capable of taking a large amount of weight. The roller bearing has

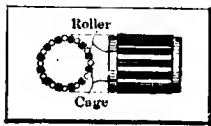

Fig. 1—Showing a roller bearing with the rollers and cage indicated.

met with great success where used upon long axle bearings, where great weight has to be supported. In this case the great reduction in friction is very evident as the line contact has great advantages over surface contact under these conditions. Lubrication is well contained in these bearings and hence it is comparatively easy to keep them in good condition. The friction in a bearing depends to a large extent upon the surface exposed. This fact is brought out well in the observation of a wagon in comparison with a drag sledge. The wagon is much more easily drawn than the sledge because it is supported at two or four points while the sledge has a considerable area which slides upon the ground. Where there is a very large weight to be born, as at the wrist pin of the engine which receives the whole force of the explosion in the cylinder as it is transferred through the piston, the plain bearing is the safest to use. The frictional losses in the wrist pin do not amount to much however as the contact is merely

oscillating, and since it is impossible to get such an adjustment where there is no lost motion whatsoever at this point the bearing surface is theoretically the line of contact between two cylinders, i. e., the wrist pin and the bearing bushing.

**HOSE CONNECTIONS OFTEN CARELESS—**It is, on the whole, rather unsatisfactory to join the water manifold to the radiator carelessly. It is necessary that the joint be carefully made and is absolutely tight. A small leak in the joint will be responsible for the loss of much of the cooling water and since a new supply is not always available, overheating of the engine may result owing to the lack of a sufficient quantity of water in the system. Temporary repairs can be instituted, but when made, should be followed up as soon as possible by a repair which will hold. The method of clamping is illustrated in Figs. 2 and 3 in which either a semi-circular or a circular metal band is placed about the tube and a clamp bolt put in the position shown.



Fig. 2—Type of clamp joint used to advantage in pipe fitting.

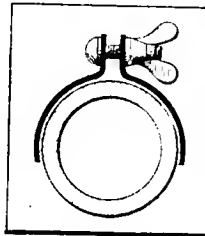

Fig. 3—Showing the winged nut on a clamp joint. This is a handy means of connecting the radiator and tubing.

**ALMOST UNBELIEVABLE REPAIRS CAN NOW BE MADE—**With the great advances in the knowledge of the oxy-acetylene welding processes the parts that were often thrown away or relegated to the junk pile or scrap heap can often be repaired. This knowledge will save the automobile owner who has been wont to purchase a new casting whenever cracked or broken parts have given trouble. In case of a break, the principal thing to remember is to save the parts, it will save expense.

In the case of a cracked water jacket the crack is first laid open by a partial heating until the full extent of the damage is determined. In case of a very thin crack

which will not open up to any extent even under the influence of heat, it is necessary to chisel the opening so that the metal from the melt bar can be run into the crack thoroughly and fill it up solidly.

The oxy-acetylene process leads all others in use for repair work where all sorts of odd jobs are encountered. It is easily carried to different parts of the repair shop and may be controlled readily by the operator, by means of the cocks on the handle. The oxygen and acetylene gas are supplied in cylinders which are renewed when empty, the tubes are attached to these tanks and the gauges are also placed on the line near them. The oxygen is taken from the tank at about 25 pounds to the square inch while the acetylene has a pressure of six to eight pounds. The part to be treated is placed in a charcoal fire and heated up to a dull red heat. This is especially necessary in the case of cast iron as it is very liable to crack after or during the operation if this precaution is not taken, owing to the unequal expansion of the metal.

After the heating has been carried out the burner is taken and the acetylene gas turned on alone, after which the oxygen is turned on until the required flame is given. The flame will vary with the nozzle which is being used. This nozzle is adapted to the work in hand, and it is one of the characteristics of an experienced man in the art of welding to be able to choose the proper tip. The flame is directed around the gap in the metal until it runs, whereupon the melt bar is placed into the aperture and allowed to melt in with the other metal until they are joined so that they become one. When welding the gray iron used in cast cylinders a flux powder of alkaline tendencies is used to bring all the impurities to the surface, so that a strong joint is made, which would not be the case where the weld was filled with impure material.

Different metals require different treatment; steel, for instance, should be hammered on cooling and then, if possible, annealed. A steel which is high in carbon will suffer in the welding process. When welding two metals of different natures together it is necessary that the melting points be within fairly good range of each other in order to get good results.

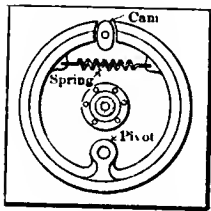

Fig. 4—Illustrating an internal expanding brake with the relative positions of the pivot and spring shown.

**INTERNAL EXPANDING BRAKES**—The internal brakes are of the expanding type, that is, they are forced against the brake drum by expanding the circle which is bound by the shoes. The brakes are called internal from the fact that they bear

against the inside of the brake drum and are so enclosed that grit and dirt cannot readily enter. The expansion is effected by a cam as shown in Fig. 4, which illustrates a brake of this type. When the cam is turned the shoes are spread apart by swinging about the pivot indicated in the figure just mentioned. An important part of the device is the spring which is shown in position; it is installed so that when the pressure on the pedal is released and the cam returns to its original position the brake shoes will not continue to bear against the drum, but will be pulled back to their normal state. A stop is placed so that the shoes cannot go back so far that there will be any lost motion in applying the brake pedal, or, in other words, that the brake shoes will bear against the drum as soon as the pedal is pushed down a very slight amount.

The greatest cause for rapid wear in a brake is the entrance of some gritty material between the shoe and the drum which will cause the brake to heat to such an extent that it will "burn out" leaving the material in a condition which greatly tends to rapid wear. This is an accident which is much more apt to occur in an external brake than in an internal as it is not so easy to cover them properly, but if the external and internal brakes act upon the same drum, if the drum becomes overheated from either shoe it will naturally affect both brakes.

**CORRECT VALVE TIMING**—In a four-cycle motor of any type or number of cylinders the exhaust valve should be opened long enough before the end of the stroke to allow the pressure to have dropped to about atmospheric before the piston has traveled any great distance on the succeeding up-stroke. The exhaust valve should remain open as long as possible, not closing at any rate until the end of the exhaust stroke and generally after the flywheel has traversed about five degrees past the upper dead center. The inlet valve should not open until after the exhaust valve has closed and should remain open for the whole suction stroke so that the full weight or charge is drawn into the cylinder.

The timing of the valves depends to a large extent upon the speed of the gases on entering and leaving the cylinder. This

speed is, for a given pressure, determined by the size of the port and the lift of the valve, so that for a relatively small port and slight lift the valve will have to open early and close late. Another factor in determining the timing of the valves besides the area of the ports and the lift of the valves, in relation to the volume of the cylinder, is the speed of rotation of the motor. In automobile motors which are generally of the high speed four-cycle type it is very usual to have the exhaust valve open forty degrees before the completion of the impulse stroke. This corresponds to about 7 inches on the flywheel in the case of a flywheel 2 feet in diameter, or, in any case, it will be one-ninth of the circumference. When the exhaust valve is opened as early as this it is not closed until relatively very late, that is, at about five degrees past upper dead center or occasionally as much as ten degrees. Five degrees would correspond to seven-eighths of an inch on the 2-foot wheel referred to above.

It must not be supposed that when it is mentioned that a certain function has a lead of so much over dead center or a lag of another quantity that it means that any great portion of the stroke is referred to, as the angularity of the connecting rod enters into the problem, and in the case of ten degrees past dead center on the flywheel only a little over nine-thousandths of the stroke, or with forty degrees about nine one-hundredths of the stroke. It is not a very profitable undertaking as a rule for the amateur to attempt to change the timing of the valves on a new automobile as soon as it arrives from the place of purchase; it is a fact, however, that a gain in power will result from a change after the motor has been in use for a length of time and has settled down to its work. It occasionally happens that a machine which, while not mis-timed, has not been set so that the greatest power possible is being derived; in this case it is possible to accomplish a gain by a series of carefully observed trials with different valve settings. It is of great importance that these trials be run off in logical sequence.

**SLOVENLY WIRING**—When it is such a simple matter to hold the wiring of the motor in such a position that it will not jump all over the engine in a series of wild gyrations while traveling a long a rough road, it is a great indication of either laziness or something else of similar nature on the part of the driver. A small T-shaped attachment as shown

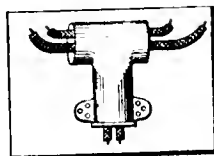

Fig. 5—T-fitting which may be used to hold wires so that they will not chafe

in Fig. 5 will do away to a great extent with the apparent desire on the part of the wires to jump through the hood.

The fitting may consist of an ordinary T-

pipe joint to which has been brazed a small flange for holding purposes. The wires are passed through the lower part of the T and out through the upper branches, whence they are conducted to the cylinders to which they belong. This will do away with any possible chafing which will be very apt to exist if the wires are allowed to fly around loosely. Another result of loose wiring is that in its working about it will tend to bend to and fro at the binding posts. This will inevitably result in its fracture. The wire itself may break within the insulation and a thing of this kind is exceedingly difficult to locate as the spark will be perfect when the wiring is in some particular position while if moved slightly it will throw the ends of the wire out of contact and cut off the spark from that particular cylinder.

**SIX-CYLINDER FIRING SEQUENCE**—If a variance of the order of firing in the different makes of six-cylinder cars may be taken as an indication, there has not as yet been any definite law evolved in regard to this matter. The wiring of the batteries and magneto are fairly well standardized and usually takes the form of that shown in the accompanying wiring diagram, shown in Fig. 6. The most marked difference in any case so far as the wiring is concerned will be the order in which the contact maker will send a current through to the succeeding cylinders. If the cylinders are numbered as shown in the cut, it may be interesting to note the order in which some of the leading makers of six-cylinder

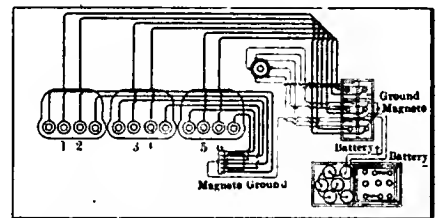

Fig. 6—Illustrating typical wiring diagram of six-cylinder motor

motors arrange their ignition. We will consider eleven makers. Of these eleven, five fired in this order: 1-4-2-6-3-5, three fired as follows: 1-5-3-6-2-4, and the others, 1-2-3-6-5-4, 1-3-2-6-4-5 and 1-3-5-6-4-2.

There are many factors which enter into the determination of the firing order, the greatest being that of getting the gas into the cylinders with as uniform distribution as possible. A manifold of a given design may give widely varying results when the firing takes place in different orders of sequence. It will be noticed that the largest percentage seems to be in favor of not allowing two succeeding cylinders to fire in succession. It is very important that the compression in each cylinder of a multi-cylinder motor should be equal, so that each crank receives the same turning moment. This is in reality much more important in most cases than the order of firing.

# Cooling Troubles—Their Symptoms

## Overheating Results from a Variety of Causes

*The cooling system of a car should be as carefully watched as any other part of the mechanism. Trouble is not always directly due to carelessness on the part of the driver, as poor design may be the guilty factor; however, it is often the indirect result of neglect on the part of those to whom the car is turned over after leaving the hands of its makers.*

**S**TARTING with the radiator and following the cooling system through its various phases, it is seen that there are a number of causes for the overheating of the motor, any one of which may give rise to at least several of the others since they are, to a large extent, dependent upon each other. For instance, if the fan is deranged so that the water in the radiator is not cooled sufficiently, it will lead to the deposit of scale on the walls or in the cells, due to the increased activity of the chemical agents within the water under the influence of the greater heat.

There are two types of fans which are in general use, that in which the fan is formed by the vanes of the flywheel and that in which it is driven off a belt from a wheel which is actuated by a reducing gear. In the case of the former, it is necessary that there be no leakage of air past the radiator, and in order to prevent it, the air is confined by means of a tight hood. The first cause of trouble is that the air finds other and easier methods of getting through to the fan than by means of the radiator. This cuts down the cooling ability of the radiator, since it is directly dependent upon the amount of air which passes through it in a given amount of time, so that in case where this type of fans are used the air-tight hoods should be inspected. Where the second mentioned type of fan is used the greatest troubles will be in the nature of its not being driven at sufficient speed, or that it has been twisted on its bracket so that it has come out of alignment. In this case the resulting

noise would soon lead to its detection. Occasionally after a belt has been used for a length of time it will stretch so that there will be a larger percentage of slip which will have to be taken up. This can be tightened by means of the adjusting device or by cutting the belt and inserting a new connection.



Fig. 2—Method of making a tight connection between the hose and the radiator. A metal clamp is fastened in place with a small bolt

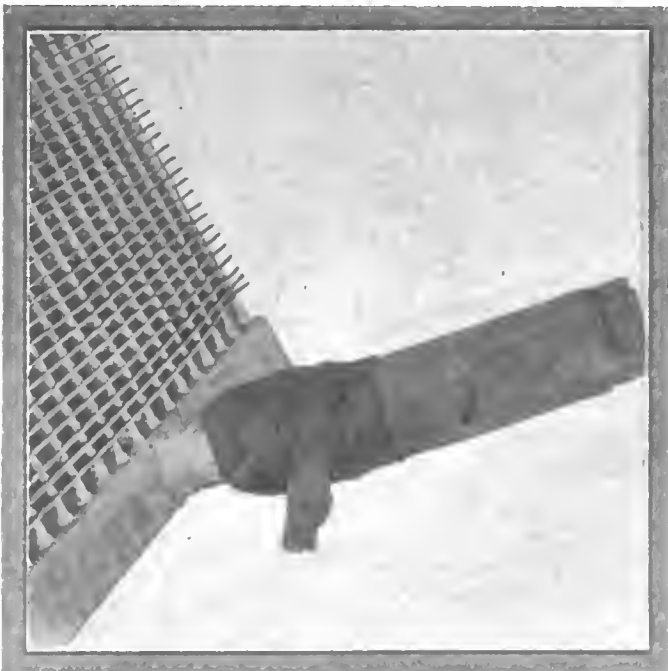

Fig. 1—Illustrating a temporary repair made on a hose connection, which, while satisfactory for a short time, should be immediately replaced by a permanent repair

The greatest damage to the system is caused by the various kinds of obstructions which clog the tubes and interrupt the circulation. The obstructions in the radiator are generally caused by deposits due to the use of impure water, while those in the other parts of the system are caused by imperfect pipe fitting or by foreign matter in the piping. The best way to keep out of radiator trouble is to use the proverbial ounce of prevention and wash the radiator frequently, both on the inside and outside, and in case the only water procurable is known to be very rich in calcium carbonate or calcium sulphate or any of the magnesium salts, some form of scale preventative of a chemical nature may be used which will go far in preventing the formation of scale. Water which contains these salts of calcium or magnesium to any extent is commonly classed as hard and may be detected by its inability to form a lather with soap. It may be remarked right here, however, that it is exceedingly dangerous and inadvisable to experiment with the many detergents which are on the market, as their action on the metal of the radiator is highly corrosive, unless it is absolutely necessary. Ordinary care and the occasional flushing out of the radiator with a small quantity of soda will generally keep it in good condition.

When the obstruction is in the water piping it is apt to be caused by careless fitting more than from any other cause. Where there is a pipe joint in which it is necessary to maintain absolute tightness there will be a gasket inserted to hold the joint tight. It is not an uncommon accident to have this gasket squeezed into the pipe so that it will choke the bore to such a degree that the capacity will be very largely cut down. In this case overheating will be a natural result and the case will be a most puzzling one, for no amount of radiator cleaning will remedy it, and the driver is very apt to think that the trouble lies in the carbureter adjustment or some other part of the mechanism which may be in a state of perfect adjustment. It is impossible to detect the defective washer or gasket until the piping is taken apart and inspected.

In the case of a thermo-syphon system the most common fault is not due to the carelessness of the driver as a rule, but to a lack of foresight in the design. This defect is that of not allowing the water in the cooler to be a sufficient height above the point at which the water re-enters the tank after having passed through the system. The water is circulated to a great degree by the steam generated above the top of the engine



Fig. 3—Showing a cracked water jacket which will allow the cooling water to run away

cylinder at the point of outlet from the waterjacketing; the flow, however, to be satisfactory, must be continuous and this is impossible if the water falls below the tube which carries the water into the cooler so in order that the water will not drop below this level after having run for a comparatively short distance, it should be a matter which is well attended to by the designer. He should be careful that the filler opening is at a good height above the top of the cylinder.

The matter of foreign material in the piping and waterjacketing is largely due to the same causes as those which have been named for the deposits of scale in the radiator. The deposit is to a great degree lime, although there is always a large amount of other matter present. The deposit will gradually accumulate, getting worse and worse until, if not attended to, it will very seriously affect the circulation and hence impair to a great extent the cooling of the motor. A reliable remedy for this as well as for the radiator trouble is hot soda, although there are several patent solutions for sale which are no doubt very good.

The water pump is very seldom the cause of any great trouble in the way of cooling, as a centrifugal pump, which is the type in general use, is so simple that it is not very liable to get out



Fig. 4—Broken water jacket which can be welded by the oxy-acetylene process if the missing part is not lost

of order in such a way that it permanently cuts off the water supply. The packing might start to leak or the pump may not be driven fast enough, but the former is merely a matter of adjusting the stuffing gland, while the latter is not very liable to ever happen since the correct speed of the pump has been determined in its relation to the engine speed.

The matter of small or contracted piping is another feature which if it were present would seriously affect the cooling system. The piping of a motor is, as a rule, designed to be of ample size to permit the required quantity of water to pass through at the correct velocity. It may be easily seen how a contraction in any part of the piping system would change the whole scheme of flow. The velocity of the water in any part of the pipe must vary inversely with the diameter of the pipe since the same quantity of water must pass through each section in a given time. Hence, the amount of water passing through the pipe in a unit of time would be governed by the amount which passed through the smallest opening in that length of time. If the piping is constricted by an indentation of more or less severe nature the required amount of water will not be circulated through the jackets and the motor will be bound to overheat.

It is, of course, very obvious that a leak in the water system will be responsible for the overheating of the motor. In this case it is not the leak which is directly responsible but the lack of sufficient water due to its having been wasted by flowing from the pipe in which the leak is taking place. Besides being in the piping the leakage may be due to a cracked waterjacket or to a punctured radiator. In the case of the piping it is very often the case that a slight leak has been repaired by the owner in an inadequate manner. An illustration of this is given in Fig. 1, in which tape has been roughly wound about the rubber tubing at the point where the water is taken from the radiator. This repair was no doubt made upon the road and intended to hold the joint until a repair shop was reached. This is often done, the only trouble is, however, that the owner generally neglects to go to the repair shop with his car after having made the temporary repair, but thinks he will take "just one more spin" before the repair is made. Many a time has the owner of a new car, or perhaps more often the new owner of an old car, started for the repair shop with the firm, but often reluctant intention of having a few minor repairs made. The temptation gradually steals upon him to "hit her up" a little before putting the car into



the tender hands of the repairman and, as a result, in a short time the driver finds himself far beyond the confines of the town with the motor perhaps running well and the temporary repair, to all appearances, as good as new. He may get through with it, but in a large percentage of cases he finds himself behind a two-horsepower country wagon trailing leisurely along by means of a rope. Human nature is naturally bound to assert itself, but incidents such as the above could, to a large extent, be eliminated by the installation of a few tools and a repair bench in the garage. The method of repairing a leaky hose joint is to cut off the worn end and fit a clamp as shown in Fig. 2. In case the hose cannot be cut off a new section will have to be purchased and the end fastened with the clamp as shown in the illustration just mentioned. It happens sometimes, though happily very rarely, that the lining of the rubber tubing used in this part of the system works loose and acts very much like a non-return valve in that it would allow the water to flow in the opposite direction, while it is washed across the hose by the water in its flow, thus sometimes closing the tube entirely. This is a very elusive mishap to locate and will often give a great amount of trouble, as the indications are the same as any other clogging and no one is apt to suspect the short piece of rubber pipe which, nevertheless, is at the source of the trouble.

When the water goes above the boiling point, which is about 212 degrees Fahrenheit, steam is given off which will cause trouble in many ways. The resulting expansion due to the latent heat of steam will give a pressure in the waterjacketing far above that ordinarily encountered. This will often find its way back into the pump and cause trouble. It may be detected by the steam which escapes from the radiator cap and other joints in the water system. When there is insufficient water in the system boiling will result and, as has already been stated, a deposit of lime with its accompanying evils will be the result. Another difficulty which, it may be happily stated, is not as common as it was at one time is the presence of air locks in the circulating system. This was caused by having large vertical reverse bends in the tubing or connecting pipes, and may be classed as a first cousin to that other trouble of somewhat the same nature, namely, that of kinks in the hose connections.

A note of warning often sounded but as frequently unheeded is to be careful that after cleaning a taken-down motor all the cotton waste is to be carefully removed and even the threads which are so frequently left upon a rough surface after having wiped it with waste are removed. These stray threads have the unhappy faculty of picking out the most pernicious spots in which to collect and clog small but important openings. Rags are often as bad in this respect and it is of great importance that care be exercised in removing any material of this nature to avoid unexpected trouble later on.

Water should not be left in the radiator or jacketing if the car is going to stand in a place where the water will freeze. In very cold weather it should be removed or else a good anti-freezing solution added to the water. The results of carelessness in this respect are a cracked water jacket as depicted in Fig. 3,

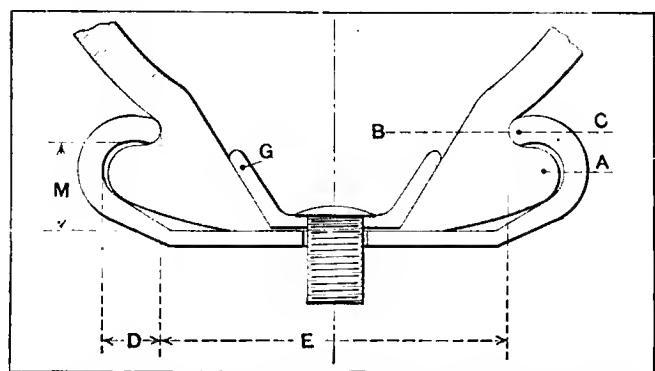

Section through the rim of an automobile wheel indicating various measurements

or in severe cases a break such as shown in Fig. 4. While these breaks can be welded, they are very nasty things to handle.

The illustrations herewith are taken from photographs which were secured by the courtesy of the Haynes Automobile Co., 1715 Broadway, New York City, who extended the privileges of their repair shop.

## Tires and Rims

*Tires are the means provided of transmitting the power from the motor to the road surface, and in a large degree the pleasure derived from a day's drive depends upon the amount of trouble given by the tires.*

**A**UTOMOBILING is nearly always exhilarating and as tires play such an important part it is a wonder owners do not pay more attention to them. There are certain things that the amateur has to be told in order that he may appreciate the service that certain parts have to perform. The weakest part of a tire is at the point where the side wall leaves the bead, and in order that the tires should give the maximum life it is necessary that they fit into the bead snugly.

The bead may be dented through running on a deflated tire or when passing over some obstacle. Passing over stone so that the bead receives a slanting blow is sufficient to cause the bead to become dented. This will unduly pinch the tire, with the result that the canvas at this point will be forced to undergo undue strain and in time give way.

Unless the tire fits the rim blowouts will not be at all unlikely. The following table shows the different dimensions of rims for various sizes of tires, and it would be well for the autoist if he has trouble with his tires to carefully measure the rims with a pair of calipers to ascertain if the dimensions are correct. It is false economy to try to fit a tire to a rim which was never intended to take it, because if the tire is too small the stretching that the tire undergoes spoils it, while on the other hand if the tire is too big for the rim it will not stay on properly. The dimensions in the table are in millimeters as it will be found, for people who are not used to working down to small fractions of an inch, that this form is simpler:

Tire Pressure.	90 lbs.	100 lbs.	120 lbs.	136 lbs.
E .....	51	62	67	77
D .....	8	9	11.5	12
M .....	12	15	16.5	16.5

The point E denotes the width of the rim at the lips, and it will be found that inside calipers are the best for making the measurement, or outside calipers may be turned, so to speak, inside out and used as inside calipers. The distance denoted by D may be best found by inserting a rule in the rim, and the same applies to M. One point that should be borne in mind is that although D may be correct as well as M, nevertheless it is necessary for E to be correct also, otherwise the tire will have a tendency to pull out of the rim.

**THE THERMO-SYPHON SYSTEM**—While it is common talk to the effect that the thermo-syphon system works by natural circulation, the fact remains that steam is generated at the hottest zone over the combustion chamber, and this steam, coming off of the surface in a slug, rushes away through the course of least resistance, and acts very much as the plunger of the pump. It has the potential force of the energy stored in it, and is perfectly capable of doing mechanical work in substantially the same way that the plunger of a pump drives water before it, or creates a depression into which water runs. In addition to the mechanical effect of the slugs of steam driven off during each power stroke, there is the natural difference in temperature between the water over the hot zones and that in the rest of the cooling system, and to some extent this difference is responsible for the circulation: this alone, however, would act sluggishly.

# Ramifications of the Maxwell

## Dealing Particularly with the "Special" Model

*It is proposed to show in this article the latest type of the Maxwell line and the distinctive features of the models, also some of the processes of manufacture. A department is set aside to the testing of the various parts before being assembled in the chassis.*

A NEW model has been added to the Maxwell line of cars manufactured by the Maxwell-Briscoe Motor Company, of Tarrytown, N. Y. It will be known as the Maxwell Special rated at 36 horsepower. In addition to this model the buyer's choice comprises the Maxwell Mercury, which is a roadster guaranteed to cover a mile a minute, rated at 30 horsepower; a 25-horsepower car known as the Maxwell Mascotte with either a touring or roadster body, ending up with the 16-horsepower runabout of the past season with certain refinements, now known as the Maxwell Messenger. The system of designating cars by name rather than by letters or numerals is a happy one, as it is more convenient to remember a car in this manner than by several meaningless hieroglyphics.

It is proposed in this article to deal more particularly with the Maxwell Special, and unless specific mention is made of any other model the description and details that follow will have reference to the Special. The motor is of the four-cylinder, four-cycle type, with the cylinders cast individually. The valves are placed on opposite sides of the motor as the cylinders have T-shaped heads. A general idea of the motor, together with the housing of the transmission and clutch units, can be seen by referring to Fig. 9, which shows the exhaust side of the motor, and Fig. 10, which shows the intake side, with the cover that encloses the timing gears, clutch and transmission removed. It will be seen in Fig. 9 that the flywheel is placed at the front extremity of the motor, and is cast from a special grade of iron, and is 19 inches in diameter. The face width is 2 1-4 inches, and in order to maintain a perfect balance both the sides and the face are ground, which operation is shown by referring to Fig. 18, from which it will be seen that the weight is carried at the periphery and the spokes form a fan to assist in inducing an air draft through the radiator. The bore of the Special model is 4 1-4 inches, and the stroke of the piston is 5 1-4 inches. The extreme length of the cylinders is 9 29-32 inches. The valves are of the mushroom type and the diameter of the valve seat open-

ing is 1 3-4 inches, and the lift allowed to the intake valves is 5-16 of an inch, while the exhaust valve is given a lift of 11-32 of an inch.

A point of which the average owner of a car is ignorant is the proper timing of his motor. In the Maxwell Special the intake valve opens 15 degrees after top dead center, or 2.487 inches on the rim of the flywheel, and closes 40 degrees, or 6.632 inches on the rim of the flywheel after the lower dead center. The exhaust valve closes 10 degrees, or 1.658 inches on the rim of the flywheel, after the top dead center and opens 40 degrees, or 6.632 inches on the rim of the flywheel before lower dead center. From this it will be seen that there is a period between the closing of the exhaust valve and the opening of the intake when the cylinder is in a manner creating a vacuum, and it has been found by the manufacturers of this car that this method of timing tends to induce a stronger depression in the carbureter, thereby filling the cylinders with a proportionately larger amount of mixture properly atomized.

The crankshaft shown in Fig. 1 has five main bearings, which are plain babbitt, and the diameter of the journals is 1 3-4 inches. The length of the front bearing, the extension of which carries the flywheel, is 3 1-4 inches long. The intermediate bearings are 2 5-8 inches, and the rear bearing is 2 13-16 inches long. It will be seen that a gear is attached to the end of the crankshaft and this forms the master pinion for driving the trains of half-time gearing. The clutch assembly is attached to the extension arm piece on the end of the crankshaft and the primary shaft of the transmission, which is of the square type, on which the sliding gears are attached, being a continuation thereof, terminating in a step type of journal, and the master part of the universal joint that is placed outside of transmission housing. The piston, together with the connecting rod, cap, bolts and shims, are shown in Fig. 21. The piston is first turned and afterward ground from a special gray iron, the grinding operation being shown in Fig. 18. The operator, in this illustration, cari-

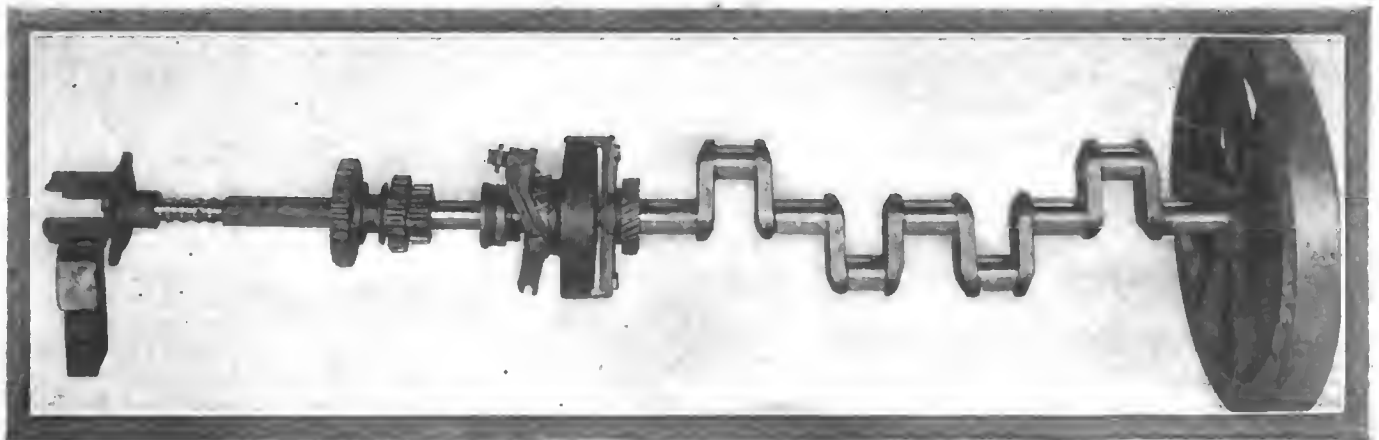

Fig. 1—Showing the assembly of the flywheel, crankshaft, clutch, primary shaft of the transmission, sliding gears and universal joint

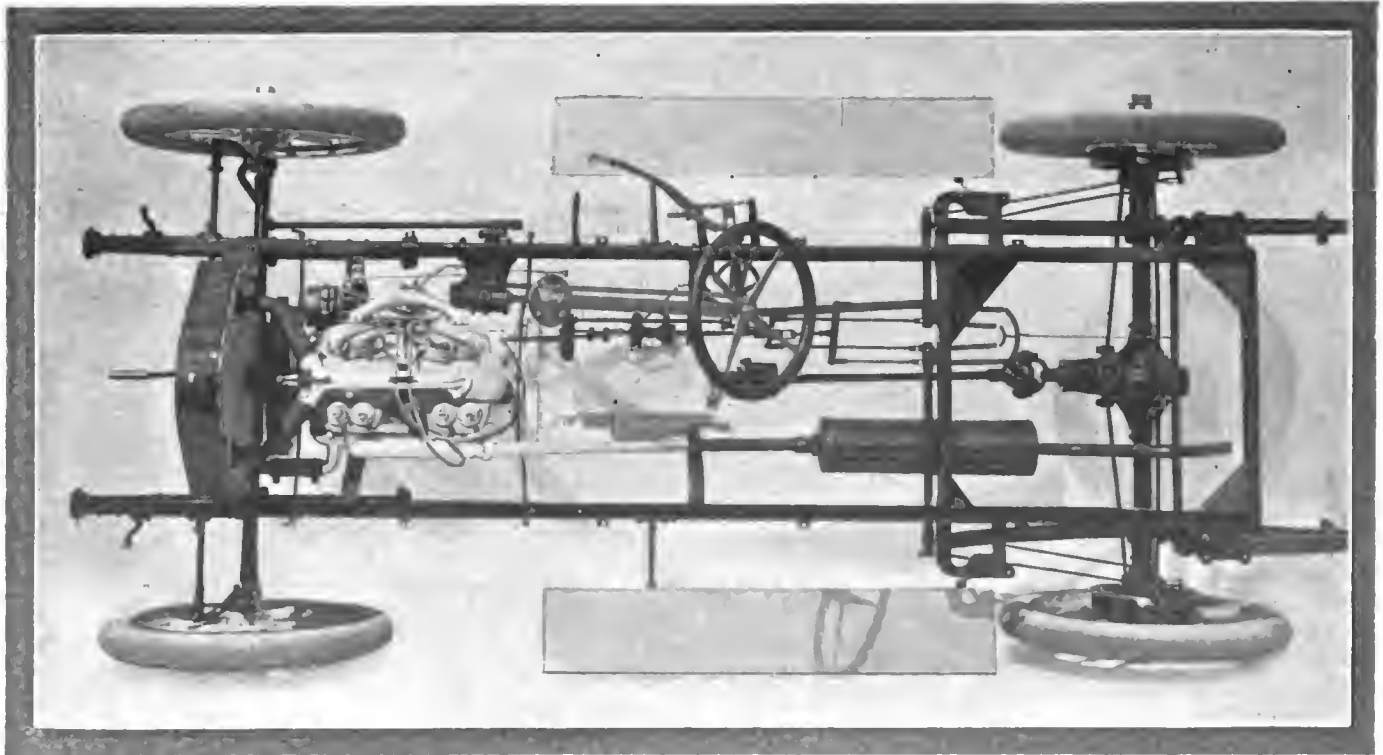

Fig. 2—Plan view of the Maxwell Mascotte chassis, showing the assembly of the motor with its three-point suspension and other details

be seen placing micrometer calipers on the piston to determine down to an infinitesimal small margin the necessary clearance for a good working fit. The cylinders are treated in a similar manner, only in this case a special cylinder grinding machine is used instead of the one illustrated in Fig. 17. Fig. 21 shows the piston P, which is fitted with four piston rings with diagonal slots. The ring R<sub>4</sub> is placed near the base of the piston, and while retaining a goodly quantity of lubricant between it and the ring R<sub>3</sub> serves, in a measure, to prevent an excess of oil escaping past it, which would thereby find its way into the cylinder spaces.

The lubrication system in this motor might be termed the semi-splash system. The actual lubrication of the reciprocating

part is dependent upon splash. Beneath each connecting rod a trough T, as shown in Fig. 21, is screwed in position by the four arms A<sub>1</sub>, A<sub>2</sub>, A<sub>3</sub> and A<sub>4</sub>, and the cap of the connecting rod is fitted with a knife-edge extension K seen in the same illustration, which churns the oil up at each revolution of the crankshaft.

Fig. 22 shows a sectional view of the base chamber with the two center connecting rods dipping into the scoops. Below the scoops the base chamber forms a reservoir for the oil that is poured in through the filler O, the correct level being ascertainable by opening the cock C<sub>1</sub> while the oil is being poured in. Should the oil, however, reach above the level of this drain-cock, the motor will not of necessity become over-lubricated unless the oscillations of an

uneven road were to cause the oil to be thrown up in larger quantities than was provided for by the makers. Fig. 9 shows the exterior of the base chamber and a gear-driven pump P driven by helical gearing from the exhaust camshaft. The oil is taken along the pipe P<sub>1</sub> in Fig. 22 into the pump and thence driven under pressure to a sight feed situated on the dashboard. In some makes of cars this feed is so small that, owing to the dirty state of the oil that is continually being passed through the motor, the sight feed becomes black and it is impossible to see whether the oil is circulating or not. This fault cannot be laid at the door of the Maxwell. Fig. 15 shows the size of the sight feed at O. After the oil has passed through the feed it returns along a single pipe which passes the whole length of the base chamber, and maintains a steady stream to each trough below the crank throws. The big ends of the connecting rod are lubricated by means of the oil that finds its way down the slot S, there being a hole drilled at the base of this into the bearing. The lower half of the bearing is also drilled so that each half of the journal receives its full quota of lubricant. The bearings are filled with an anti-friction metal and five shims of varying thicknesses are provided for each connecting rod so that an infinitesimally small amount of wear can be taken up as soon as it becomes apparent. Refinements of this description make the possessor of a car feel more confident in its maintenance. The length of the piston is 4.5-8 inches and weighs 61 ounces, and the diameter of the piston pin is seven-eighths of an inch. The camshafts of the motor are driven by helical-cut gears driven from the master wheel,

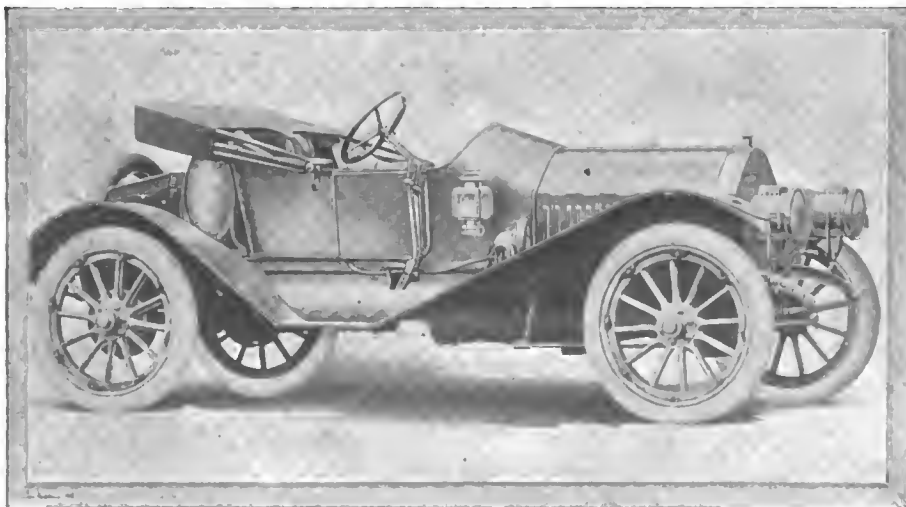

Fig. 3—General appearance of the Maxwell Mercury Roadster, with vestibule body

which is attached to the crankshaft. The diameter of the camshaft is three-fourths of an inch and is supported by five plain babbitt bearings which are driven into the aluminum housing, and afterward reamed to size. The cams are attached to the camshaft by means of taper pins. Fig. 14 shows the operation as carried out in Tarrytown of cutting the gears for the halftime wheels. Both sides of the motor, as can be seen from Figs. 9 and 10, are fitted with inspection doors which make it possible to readily inspect the working parts of the motor without taking same asunder. The crankshaft is held in position at its front and rear extremities by covers formed integral with sliding blocks that complete the housing fore and aft of the base chamber. This style of fitting is carried out in the transmission, which makes it possible after the cylinders have been removed to lift out the whole unit as shown in Fig. 1.

In Fig. 12 is shown the front end of the motor and the method in which the Splittorf magneto is held in position. The intake camshaft is extended through the base chamber and attached to it is a gear wheel which meshes with the gear attached to the armature shaft of the magneto, and being geared two to one, the magneto runs at engine speed. A cover is provided that fits over the gears and in order to eliminate noise the magneto gear wheel is made of compressed fiber faced on both sides with a sheet of steel to prevent any expansion under load. The extension of the crankshaft carrying the flywheel also forms the resting place for a pulley wheel which drives the fan belt. The ignition is obtained by means of a magneto in connection with a

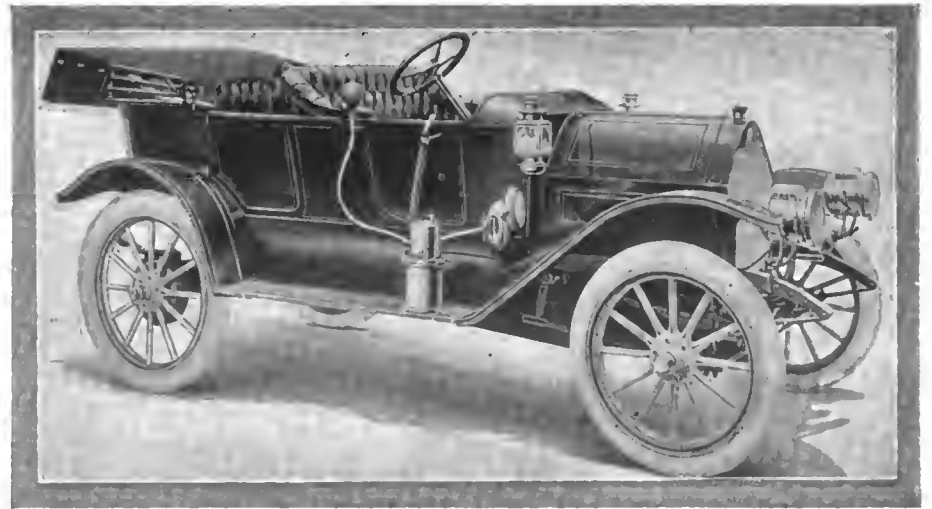

Fig. 4—Maxwell Mascotte 25-horsepower touring car with flush-sided fore-door vestibule body

non-vibrating coil and batteries for starting.

The location of the coil is well shown in Fig. 15, where it will be seen that a switch is provided upon the coil controlling both battery and magneto ignition. Fig. 9 shows the method adopted on this model of casting the cylinders and introducing the water to the lowest point of circulation at W1, W2, W3 and W4. The water is circulated on the thermo-syphon principle, the pipe conducting the water back to the radiator being of large diameter and bifurcated at the point where it leaves the forward cylinder, entering the radiator at two points a little over half way up, instead of at the top as is usual. A fan driven by a circular rawhide belt provided with a ready means of taking up slackness maintains a good

suction of air through the radiator at all speeds of the motor, and as it runs upon ball bearings little power is taken up in its operation.

The carbureter, of the float feed constant level type, is located on the right-hand side of the motor and placed sufficiently high to permit of easy adjustment if it should be found necessary at any time.

The clutch employed on this model is of the multiple-disc type, both sets of discs being made of steel with ground faces. The component parts of the clutch may be seen by referring to Fig. 6. The part A is attached to the crankshaft, and bolted thereto by means of studs S and S1 is a cross-head C. This has two protrusions upon which the part is resting engaging the jaws J and J1. The disc D with a castellated shaft

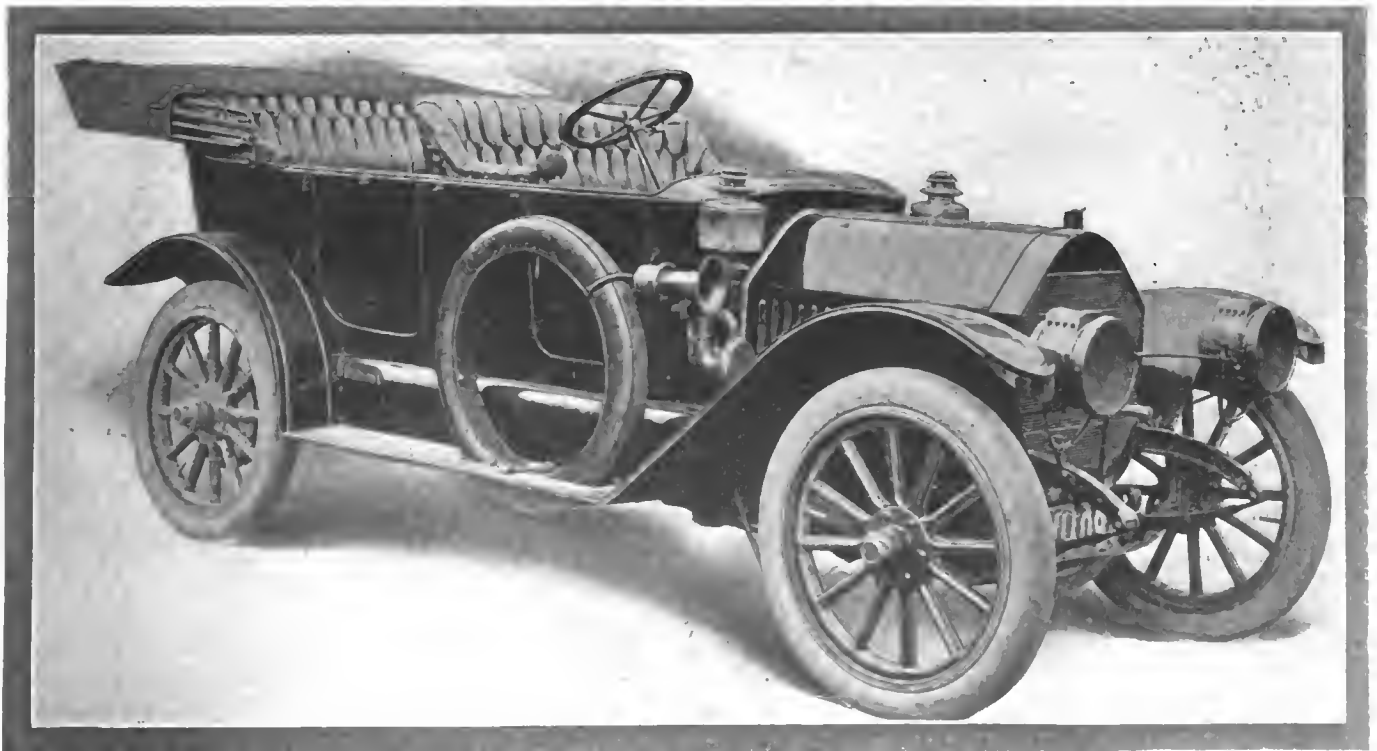

Fig. 5—Showing the Maxwell Special 36-horsepower fore-door touring car with full equipment



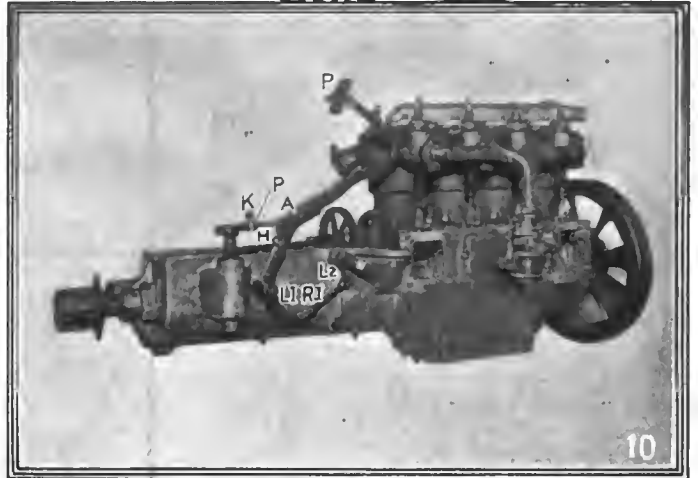
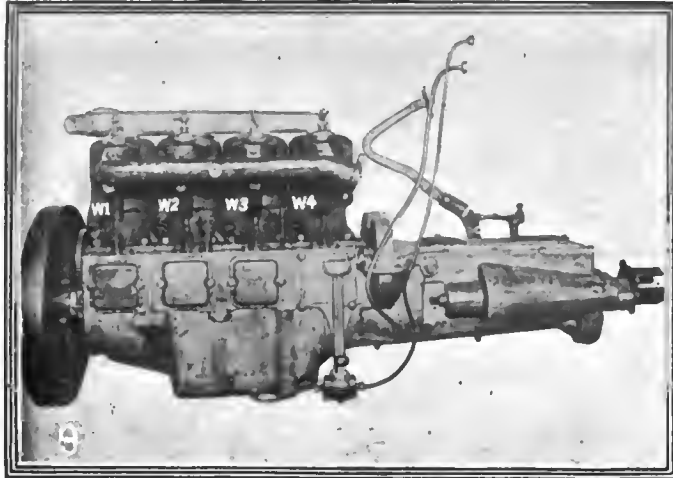
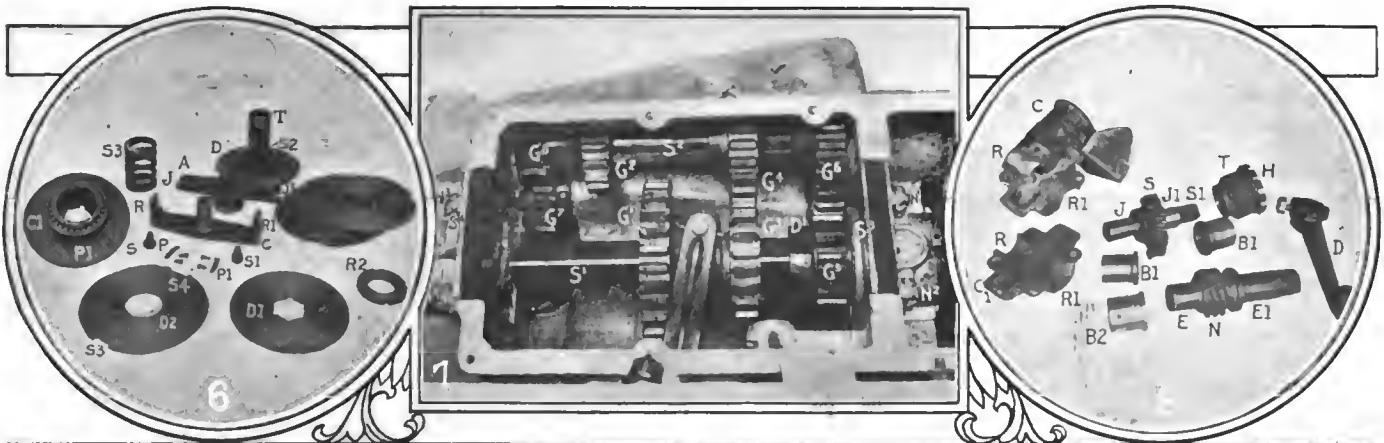

Fig. 6—Showing the various component parts forming the clutch assembly

Fig. 7—Plan view of the transmission as fitted to the Maxwell Special

Fig. 8—Various parts forming the general assembly of the steering mechanism

Fig. 9—Exhaust side of the Maxwell Special motor, showing the method of obtaining a three-point suspension and the lubricating pump

Fig. 10—Intake side of the Maxwell Special motor, showing the adjustable valve push rods, and half-time gearing and pedal control

S2 passes over the journal J2 and alternate discs of the type as shown at D1, which have six slots cut in them to correspond with the keys on the shaft S2, form the driving members. The ribs R and R1 engage with the slots S3 and S4 of the disc D2 which alternate with the discs of the type shown at D1. The plate P1, the inside of which is cut with keyways, engages with the keys on the shaft S2, and the pressure of the spring S3 maintains the plates in contact relation. The ring R2 is screwed on to the threads T, thereby providing adjustment in the case

of wear. A collar C1, which is at the same time a ball bearing, receives the engagement fork and compensates for the thrust when the clutch is disengaged. The parts P and P1 are attached to the ends R and R1 by the set screws, thus preventing the plates from expanding beyond a given limit. In order that the plates may properly disengage the driven plates of the D2-type they are cut at four points and the edges turned outward as a substitute for disengagement springs. The clutch is operated by a pedal P1, shown in Fig. 15, which, at the same time, serves to

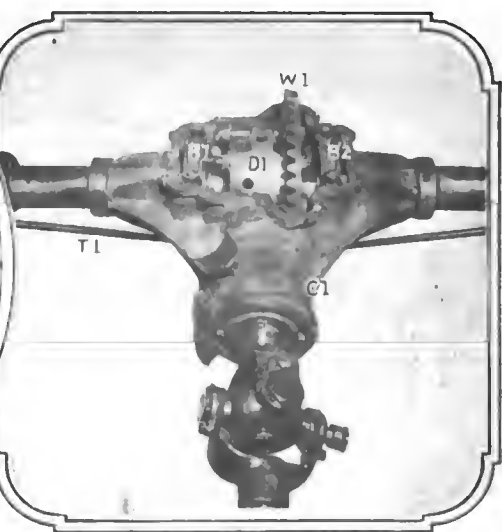
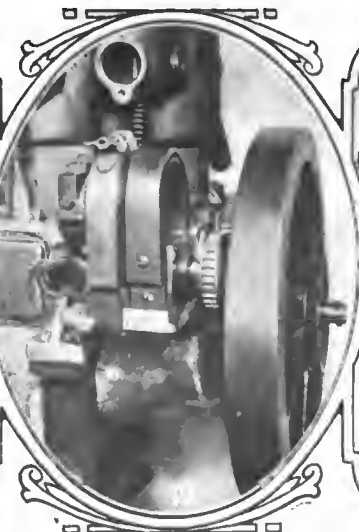
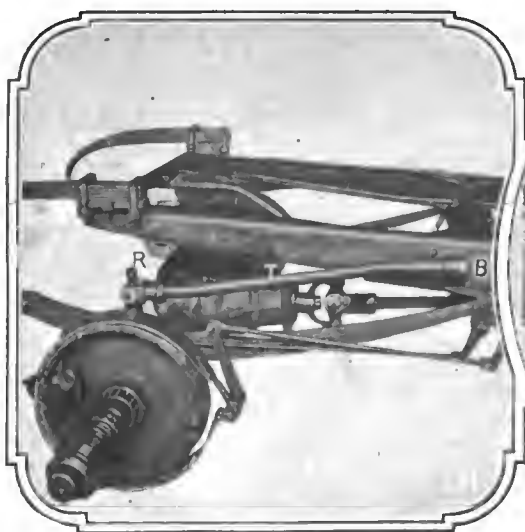

Fig. 11—View of the brakes of the Maxwell Special with the wheel removed showing the jackshaft, torque rod and spring suspension

Fig. 12—Magneto upon a ledge of motor casting and method of holding same in position

Fig. 13—View of the floating rear axle of the Maxwell Special, showing the rear propeller shaft, universal joint and the differential



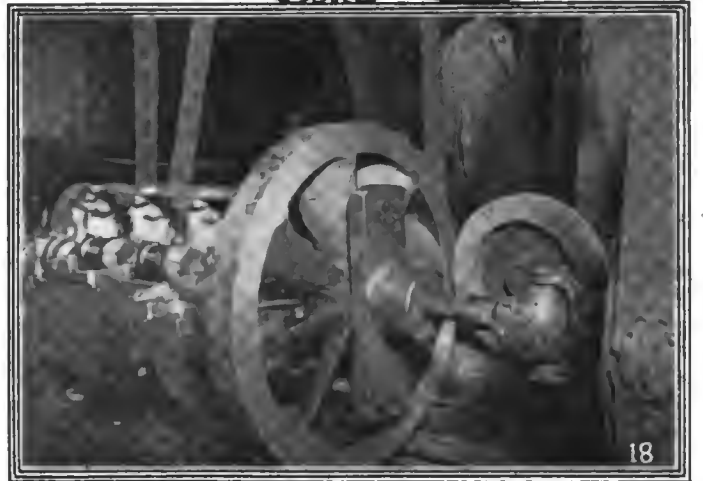
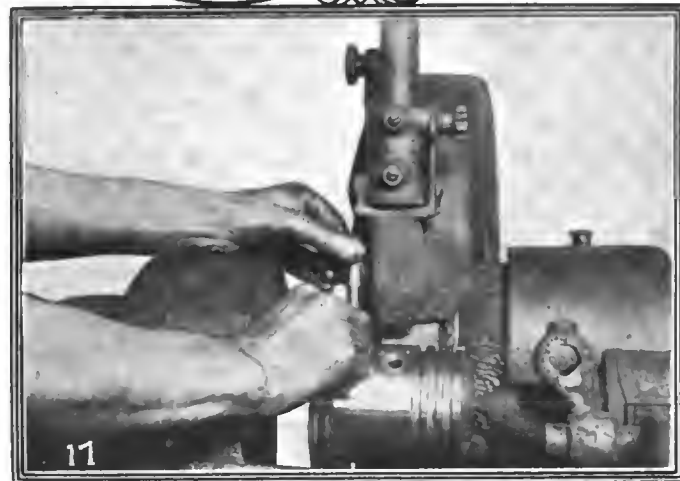
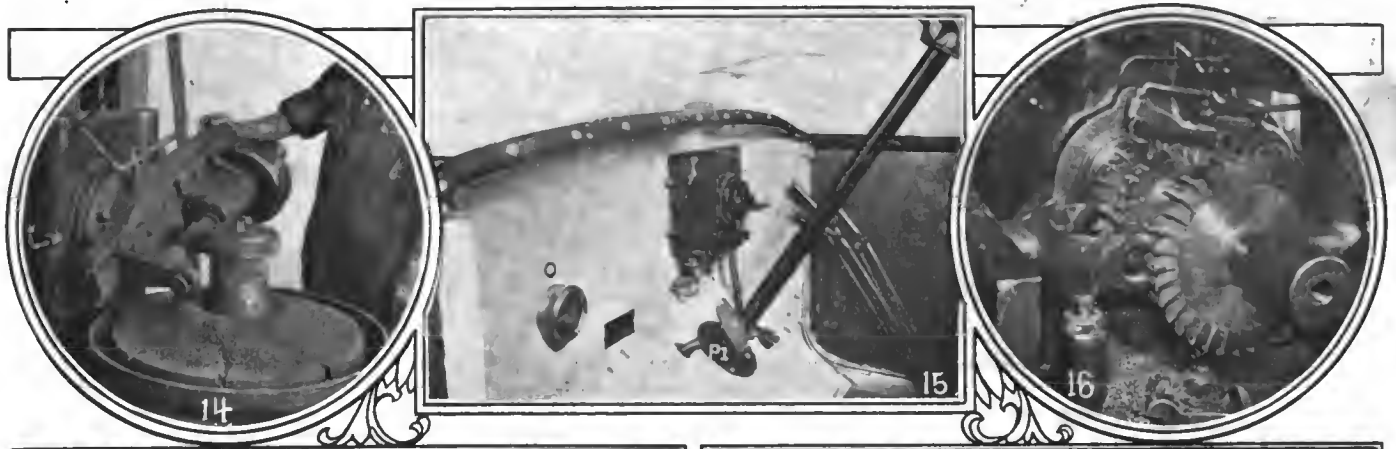

Fig. 14—Showing the method employed in Maxwell plant of cutting timing gears

Fig. 15—View of the aluminum floorboards and curved dash, showing the various control mechanisms

Fig. 16—Method employed of surfacing four sides of universal joint fork at once

Fig. 17—In order to obtain an accurate fit of the piston in the cylinder grinding to close limits is employed

Fig. 18—Showing the method of grinding the faces of a flywheel using a proper crankshaft and base chamber as a jig

apply the emergency brake when pushed right home. The general assembly of the pedal and interlocking mechanism is shown in Fig. 10. When the pedal P is depressed the lever arm L1 is drawn backward carrying with it the rod R1 and the lever L2. This lever is attached to a cross-shaft inside the clutch housing to which in turn is attached a cam. This cam forces the disengagement fork backward and an adjusting screw as provided serves to regulate the amount of disengagement. The hole H receives the rod that operates the emergency brake and by de-

pressing the pedal farther than is necessary to disengage the clutch the brake is brought into action. The knob K in Fig. 10 is connected to the change-speed lever, and a device is provided which makes it impossible to change speed unless the clutch is withdrawn, or to engage the clutch unless the gear lever is either in the neutral or one of the gear positions. This consists of a plate P which rotates with the knob K and fitted with slots and it is necessary for the arm A of the change-speed pedal to engage one of these slots otherwise the clutch is withheld. The

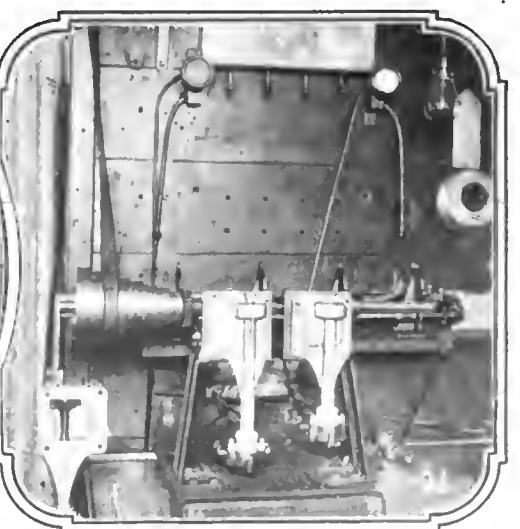
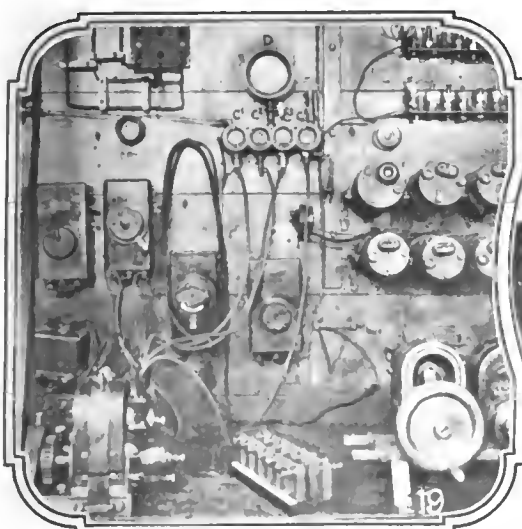

Fig. 19—Testing hench in the Maxwell plant for controlling all electrical equipment before going into the car

Fig. 20—Method employed in the Maxwell plant of testing for tension of piston rings

Fig. 21—Method employed of testing the lubricating oil pumps at various speeds by means of a belt and step pulleys

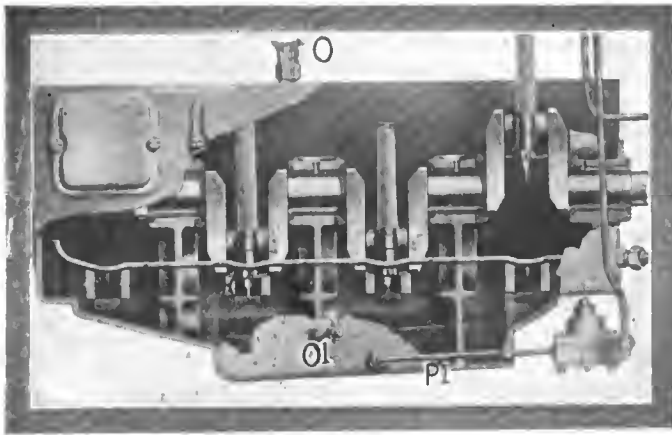

Fig. 22—Section through the Special motor, showing the connecting rods dripping in the troughs, the oil reservoir, oil pump and leads

emergency brake, which is operated by a lever placed on the right of the driver, also disengages the clutch in the same way as indicated by the emergency brake pedal, a separate cam being employed. Ignition and throttle levers are provided below the steering wheel, working on ratchet sectors, and a pedal is also employed to control the gases. The general control can be seen by referring to Fig. 15. The transmission is shown as seen from above in Fig. 7. The lever which operates the train of sliding gears works in a push-through type of quadrant. The gear  $G_1$  when meshing with  $G_2$  gives the first speed. When the gears  $G_3$  and  $G_4$  are in mesh, as shown in the illustration, the second speed is in operation. The high gear is obtained when the dogs  $D_1$  are caused to mesh with the corresponding members in the interior of  $G_3$ .  $G_5$  is attached to the extension of the clutch shaft and is in constant mesh with  $G_6$ . The gear  $G_5$  has a bronze bush within which the extension of the shaft  $S_1$  runs. The power is transmitted from  $G_5$  to  $G_6$  and thence to the several gears situated on the shaft  $S_2$ , and so back to the primary shaft  $S_1$  when the gears are caused to mesh by the shifting fork  $F_1$ . The reverse is obtained by meshing the gear  $G_1$  with the gear wheel  $G_7$ . In this case the power is transmitted from  $G_5$  to  $G_6$ , thence to  $G_8$ , which is in constant mesh with  $G_7$ , and so back to  $G_1$ .

The secondary shaft  $S_2$  is carried at its forward and rear extremity upon long roller bearings, and the primary shaft  $S_1$  on anti-friction white metal bearings. The slides  $S_3$  and  $S_4$  form the upper half of the bearings and are detachable by removing the nuts  $N_1$ ,  $N_2$ ,  $N_3$  and  $N_4$ . The cover that encloses the transmission is made in one piece together with the part that encloses the timing gears and clutch housing, and is readily removable for the purpose of inspection. The power is transmitted from the transmission to the live rear axle by means of a propeller shaft fitted at the forward and rearward ends with universal joints, the rear universal joint being shown in Fig. 13. The live rear axle is of the full-floating type and this is shown in Fig. 13 with the half cover removed. The driving pinion together with its bearings is housed in the part of the casing marked  $C_1$ , and the differential assembly comprising the crown wheel  $W_1$ , differential cage  $D_1$  and the supporting bearings are held in position by the braces  $B_1$  and  $B_2$ . When these are removed it is possible to lift the differential bodily from the housing should this be found necessary at any time, of course, after the jackshafts have been withdrawn. A tie rod  $T_1$  is placed beneath the axle with an adjustment at either extremity and serves as a strengthening member. Fig. 11 shows the assembly of the brakes, the jackshaft and the torque member, as well as the three-quarter elliptic springs, and the method of attachment of the latter. The torque tube  $T_1$  is attached at its rear extremity to an arm and at the forward extremity to a ball socket.  $B$  attached to the side member of the chassis. Rubber buffers are provided to prevent the chassis frame striking the springs, the forward ends of which are supported in a common bracket that

is used at the same time as the supporting member for the brake levers. Both the brakes operate upon the common brakedrum, the outside diameter of which is 12 inches, and the face being 1 3/16 inches. The friction surface thus obtained is 82 1/2 square inches per brake. The operation of milling the four surfaces of the universal joint is shown in Fig. 16 in which four cutters rotate at the same time and plane the interior and exterior surfaces of the fork. The rear springs are 50 1/2 inches long and 2 inches wide, and as it can be seen by Fig. 11, are of the three-quarter-elliptic type. The front suspension of the chassis is taken care of by semi-elliptic springs of the same width as the rear, but 36 inches in length. The front axle is an I-beam drop-forging and the wheelbase of the car is 114 inches having a tread of 56 inches. The wheels are 34 x 4 inches and are fitted with quick detachable rims. The steering assembly is shown in Fig. 8. It is of the worm-and-sector type, the sector fitting into the recesses  $R$  and  $R_1$  of the casing  $C$  and the cover  $C_1$ . The journals  $J$  and  $J_1$  run respectively in the bearings  $B$  and  $B_1$  which are turned from steel, case-hardened and ground to fit. The sector  $S$  engages with the worm  $W$ , which latter is held in position at its lower extremity in the bronze bushing  $B_2$ , which fits into a recess of the casing  $C$ . The upper end of the worm-shaft is held in position by the threaded cover  $T$  which is provided with a bronze liner. The adjustment of the worm and sector is effected by tightening of the slotted head,  $H$  of the part  $T$ . The drop arm of the steering  $D$  is attached to the square end  $S_1$  of the sector  $S$ , and a bolt which engages with a slot in one of the angles of the squares maintains the parts rigid.

The general appearance of the Maxwell "36" can be seen by referring to Fig. 5, in which it will be noticed that the shape of the radiator has been altered and is now made of the true honeycomb type. The front compartment of the fore-door body is provided with ventilators, thereby removing an objection that is sometimes made for this style of coach work, and in order to better carry the spare tire, a countersunk well is formed in the runningboard as shown in the illustration. Besides supporting the tire better, the reduction in height greatly improves the appearance of the car. It will be noticed that the side balances between the runningboard and the chassis frame entirely cover in such parts as spring shackles and brake levers, and give the car a very clear aspect. The Maxwell Mercury mile-a-minute roadster is shown in Fig. 3, with large capacity gasoline tank, waterproof baggage compartment and spare tire carried behind the bucket seats. The general appearance of the Maxwell Mascotte 25-horsepower touring car, having a 4 x 4-inch motor, is shown in Fig. 4, the chassis of which is shown in Fig. 2.

In order to ensure that the parts that are fitted in Maxwell cars have been thoroughly tested before being delivered to the chassis assembling department, a special force provided with the proper facilities makes a thorough test of the various assemblies in the first place. Fig. 21 shows the manner in which the lubricating oil pumps are attached by suitable means to an improvised camshaft. With the aid of the step pulleys it is possible to cause the pump to rotate at a speed equivalent to from 4 to 60 miles per hour. The oil is then forced to gauges which are placed on the testing board, as can be seen by referring to the illustration, and the flow thereby ascertained. It is not often that a leak in this type of pump occurs, but it may happen that the gears are either too tightly in mesh or not enough so, in which case all errors can be rectified before the car is handed over to the customer.

It is of vital necessity for any company who wishes to obtain the confidence of the buying public that it should make independent tests of all apparatus that it does not manufacture itself. A point that is sometimes overlooked by testers is that although a spark plug may fire perfectly under atmospheric conditions, nevertheless, when under the pressure of the compression in the cylinder, which, for example, may be 70 pounds, the plug would utterly fail. The method adopted in the Maxwell plant of testing all ignition apparatus that goes into the cars is shown in Fig. 19. The magneto is fitted to a base and rotated at varying

speeds by means of a belt. The spark plugs are screwed into small chambers C<sub>1</sub>, C<sub>2</sub>, C<sub>3</sub> and C<sub>4</sub>, provided with glass windows. Pressure is then introduced into these chambers, the amount being indicated by the dial D. A relief valve V placed in the air circuit regulates the amount of pressure in the small compartments and by turning this either to the right or left, in which case the pressure is varied, it is possible to ascertain if either the plug or the magneto which includes the step-up transformer coil are in working order.

In order that the compression of the motor in each of the four cylinders should be maintained uniform, it is necessary that the tension of the piston rings should be equal, for, unless this is so, a certain amount of compression will be liable to leak, thereby upsetting the carefully planned calculations of the designers. The method adopted can be seen by referring to Fig. 20. A bracket is provided in which the lower half of the piston ring is attached by means of a thumb-screw. The opposite side of the slot is then attached to a bracket having two arms, from which is suspended a hook which in turn carries a weight balance. The operator in this instance is seen placing an additional weight upon the balance, and a ready calculation of the weights imposed will give the tension of the ring.

### A Muddy Weather Tip

**S**TARTING a car on a muddy day is a most disagreeable undertaking, as the starting handle is usually besmeared with mud. This may in a measure be overcome by fitting a boot for the handle to rest in, but the leather soon becomes sodden with moisture and the consequences are almost as bad as if no protection at all were used.

Quite apart from the inconveniences that attend the starting there is another aspect that is more important. The mud that

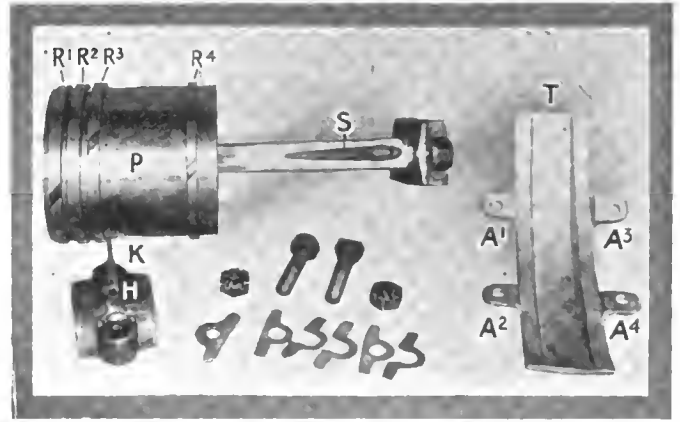

Fig. 23—Showing the piston, connecting rod, cap and shims and one of the troughs used in the lubricating system

is thrown up by the front wheels bespatters the face of the radiator and quite a large proportion is sucked between the interstices thereby restricting the flow of air that has to pass in order to effectively cool the water. Some of the foreign matter finds its way into the motor compartment and if allowed to remain will cause rust to set in, the disadvantages of such a state of things being obvious.

In order to overcome these inconveniences, a pair of leather flaps can be made so that they can be attached by strips extending sufficiently low to protect the starting handle and carried up slightly above the frame to protect the radiator. Being detachable and perhaps detracting from the general appearance of the car, they may be carried under the seat ready in case of need.

# Calendar of Coming Events

## Handy List of Future Competitive and Show Fixtures

Shows	
Jan. 1-5, 1912.....	New York City, Grand Central Palace, Annual Show, Automobile Manufacturers' Association of America.
Jan. 6-13.....	New York City, Madison Square Garden, Twelfth Annual Show, Pleasure Car Division, Automobile Board of Trade.
Jan. 10-17.....	New York City, Madison Square Garden, Annual Show, Motor and Accessories Manufacturers.
Jan. 10-17.....	New York City, Grand Central Palace, Twelfth Annual Show, National Association of Automobile Manufacturers.
Jan. 15-20.....	New York City, Madison Square Garden, Twelfth Annual Show, Commercial Division, Automobile Board of Trade.
Jan. 27-Feb. 10....	Chicago Coliseum, Eleventh Annual Automobile Show under the auspices of the National Association of Automobile Manufacturers.
March 2-9.....	Boston, Mass., Tenth Annual Show, Boston Automobile Dealers' Association, Inc.
Race Meets, Runs, Hill-Climbs, Etc.	
Sept. 6-9.....	Buffalo, N. Y., Grade I, Reliability Run, Automobile Club of Buffalo.
Sept. 8-9.....	Hamline, Minn., Track Races, Minnesota State Automobile Association.
Sept. 9.....	Augusta, Me., Hill Climb.
Sept. 9.....	Cincinnati, O., Road Race, Fern Bank Dam Association.
Sept. 9.....	Hartford, Conn., Track Races, Connecticut Fair Association.
Sept. 9.....	Port Jefferson, L. I., Hill Climb, Port Jefferson Automobile Club.
Sept. 9.....	Riverhead, L. I., Road Race, Port Jefferson Automobile Club.
Sept. 12-15.....	Omaha, Neb., Third Annual Endurance Run, Omaha Motor Club.
Sept. 13.....	Grand Rapids, Mich., Track Races, Michigan State Automobile Association.
Sept. 15.....	Knoxville, Tenn., Track Races, Appalachian Exposition.
Sept. 16.....	Syracuse, N. Y., Track Races, Automobile Club and Dealers.
Sept. 16-17.....	Kansas City, Mo., Track Meet.
Sept. 18-20.....	Chicago, Ill., Commercial Reliability Run, Chicago Motor Club.
Sept. 19.....	Burlington, Vt., Reliability Run, Merchants' Protective Association.
Sept. 23.....	Philadelphia (Point Breeze), Track Races, Philadelphia Automobile Trade Association.
Sept. 23-25.....	Detroit, Mich., Track Races, Michigan State Agricultural Society.
Sept. 25-30.....	Atlantic City, N. J., Convention and Exhibition of the Carriage Builders' National Association.
Sept. ....	Denver, Col., Track Races, Denver Motor Club.
Sept. ....	Steubenville, O., Hill Climb, Automobile Club of Jefferson County.
Oct. 6-13.....	Chicago, Ill., Thousand-Mile Reliability Run, Chicago Motor Club.
Oct. 7.....	Danbury, Conn., Track Races, Danbury Agricultural Society.
Oct. 7.....	Philadelphia, Fairmount Park Road Races, Quaker City Motor Club.
Oct. 7.....	Springfield, Ill., Track Races, Springfield Automobile Club.
Oct. 13-14.....	Atlanta, Ga., Track Races.
Oct. 14.....	Santa Monica, Cal., Road Races.
Oct. 14 (to 25)....	New York City, Start of the Annual Glidden Tour, en route for Jacksonville, Fla.
Oct. 16-18.....	Harrisburg, Pa., Reliability Run, Motor Club of Harrisburg.
Nov. 1.....	Waco, Tex., Track Races, Waco Auto Club.
Nov. 2-4.....	Philadelphia, Reliability Run, Quaker City Motor Club.
Nov. 4-6.....	Los Angeles, Phoenix Road Race, Maricopa Auto Club.
Nov. 9.....	Phoenix, Ariz., Track Races, Maricopa Automobile Club.
Nov. 9, 10, 12....	San Antonio, Tex., Track Races, San Antonio Automobile Club.
Nov. 27.....	Savannah, Ga., Vanderbilt Cup Race, Savannah Automobile Club.
Nov. 30.....	Los Angeles, Cal., Track Races, Motordrome.
Nov. 30.....	Savannah, Ga., Grand Prize Race, Savannah Automobile Club.
Nov. ....	Columbia, S. C., Track Races, Automobile Club of Columbia.
Dec. 25-26.....	Los Angeles, Cal., Track Races, Motordrome.
Foreign Fixtures	
Sept. 9.....	Bologna, Italy, Grand Prix of Italy.
Sept. 10-20.....	Hungarian Small-Car Trials.
Sept. 16.....	Russian Touring Car Competition, St. Petersburg to Sebastopol.
Sept. 17.....	Semmering, Austria, Hill Climb.
Sept. 17.....	Start of the Annual Trials Under Auspices of <i>l'Auto</i> , France.

# THE AUTOMOBILE

Vol. XXV

Thursday, September 7, 1911

No. 10

## THE CLASS JOURNAL COMPANY

H. M. SWETLAND, President  
A. B. SWETLAND, General Manager

231-241 West 39th Street, New York City

### EDITORIAL DEPARTMENT

GEORGE M. SCHELL

JAMES R. DOOLITTLE  
J. EDWARD SCHIPPER

HUGH P. MacCONNELL  
HANS WEYSZ

### ADVERTISING DEPARTMENT

W. I. RALPH, 1085 Old South Bldg., Boston  
C. H. GURNETT, 910 South Michigan  
L. G. VOGEL, Avenue, Chicago  
T. B. VAN ALSTYNE, New York and Phila.  
H. L. SPOHR, New York

LOUIS R. SMITH, New York  
FRANK B. BARNETT, 309 Park  
Building, Cleveland  
H. H. GILL, 627 Ford Building,  
Detroit

Cable Address - - - - - Autoland, New York  
Long Distance Telephone - - - - - 2048 Bryant, New York

### SUBSCRIPTION RATES

United States and Mexico - - - - - One Year, \$3.00  
Other Countries in Postal Union, including Canada - - - - - One Year, 5.00  
To Subscribers—Do not send money by ordinary mail. Remit by Draft,  
Post-Office or Express Money Order, or Register your letter.

### FOREIGN SUBSCRIPTION AGENTS

ENGLAND:—W. H. Smith & Sons, Ltd., 186 Strand, London, W. C., and all book-  
stalls and agencies in Great Britain; also in Paris at 248 Rue de Rivoli.  
FRANCE:—L. Haudry de Saunier, offices of "Omnia," 20 Rue Duret, Avenue  
de la Grande Armees, Paris.  
GERMANY:—A. Seydel, Mohrenstrasse 9, Berlin.

Entered at New York, N. Y., as second-class matter.  
The Automobile is a consolidation of The Automobile (monthly) and the Motor  
Review (weekly), May, 1902, Dealer and Repairman (monthly), October, 1903,  
and the Automobile Magazine (monthly), July, 1907.

### GREATER ACCESSIBILITY NEEDED

**A**CCESSIBILITY is more needed on many cars than any other feature at the present time. Accessibility is needed because it reduces cost of car operation. The lack of accessibility means expense. That car does not exist which will not give trouble sooner or later; it may have a clean sheet for a good many miles, but the day will come when an exhaust valve spring will weaken and a new spring have to be used; then comes the test of accessibility. It is a difficult task to change a valve spring on some motors. Often on the exhaust side the manifold is carried so low down that it is difficult to get an ordinary valve-removing tool into position without danger of getting the hands burned by rubbing against the hot manifold. Added to this complication is that of having the magneto mounted so that it is directly in the way of reaching one, or perhaps two, of the springs, and here is where more time and patience are lost.

The foregoing is but an introduction to the opening chapter of what might develop into a resumé on inaccessibility in motor cars. Go to the opposite end of the car and try to adjust the emergency or foot brakes on not a few machines. In some it is an impossibility to adjust them without getting on your back on the ground, with your head perhaps in advance of the axle. When in this position it is further necessary to work your entire arm up through a labyrinth of rods, etc., to some out-of-the-way wingnut or perhaps an ordinary nut with lock nut. These have to be turned by a special wrench; it would be bad enough if they could be worked by hand,

but demanding the use of a special wrench in such a restricted quarter adds to the misery. When the thought-to-be-right adjustment has been made the driver, owner or passenger, worms himself out from under the car and tries his brakes only to find that they have been over-adjusted or not adjusted quite enough. He repeats his laborious performance once again and, if good luck is not on his side, he may have to perform the task a third time. It takes a lot of patience for such gymnastics; it takes a lot of clothes also, and if the owner has put on a holiday suit it is ready for the cleaners, even although he has made use of a long duster in his work.

The majority of motors need to have the carbureter primed occasionally before starting. There are a score of cars at present on the market in which you run a big chance of getting three or four grease spots on the coat sleeve every time you reach in to press on the priming rod. This is expense to the owner. He may not charge it up to the operating expenses of the car for the year, but he should. It is just as much an expense as buying a new tire is; just as much an expense as having the brass work cleaned; just as much an expense as having the body polished from time to time, and just as much an expense as having the carbon removed from the cylinders. Car owners should be honest with themselves and keep the expense account correctly.

Every car owner should remember that inaccessibility is costly and particularly so when his car goes into the repair shop to have some part repaired or replaced. Every other part of the car that has to be removed before the broken part can be reached is adding to the cost of the repair. But this is only half of the story, as these inaccessible parts have to be put back in place again and the owner should bear in mind that he pays his 75 cents an hour for his inaccessibility. This is a part of the cost of operation. Not a few owners have wondered at the repairman's figures showing a certain repair on one make of car at a certain figure and the same repair on another car at nearly double the price. Inaccessibility is the answer. In buying a car the buyer should look to the costs of inaccessibility. He should look into the accessibility of the carbureter and its adjustments, to the brake adjustments, to the crankcase oil drains, to the clutch lubrication, to the lubrication of the universal joints, to the valve springs, to the fan adjustment, to the magneto, the water pump, the ignition wiring, the grease cups on the running gear in hidden places, as well as to a dozen or more details that will come up in the ordinary running of the car.

It would be a blessing to the industry if there were a reliability run every year in which the designing engineers were the drivers and mechanics. It would show to them the error of their ways in hundreds of cases. The points in question are often not engineering problems at all—the engineering design of the major part has been correctly carried out—it is the positioning of some appurtenance that gives the trouble. A carbureter may be of the best design obtainable, but if it is mounted with the needle valve or throttle adjustment between it and the motor crankcase it is entirely wrong. Cases of this kind are on record to-day; some makers who had such conditions a year ago have since altered them.

As a solution of the problem, or, better still, as a method of bringing accessibility more to the front, THE AUTOMOBILE suggests an accessibility contest for cars.



Instead of running the cars on the roads they are simply parked and the trial consists of removing parts from the cars and replacing them. Such a contest offers an unlimited field.

A few of its possibilities are: The time required to adjust each set of brakes; time needed to jack up a front or rear wheel; time to remove a carbureter; time to drain off water from a carbureter; time needed in changing a spark plug; time needed in draining the dirty oil from the motor crankcase and refilling; time needed to empty the gasoline tank and refill; time needed to ad-

just the clutch spring tension; time required to turn up all of the grease cups on the car; time that is taken to change a valve spring; time needed to put on a new fan belt; time required to adjust the lower bearing of a connecting rod; time to take off and replace the radiator; time for removing and replacing the magneto; removal and replacement of the water pump; putting on a new ignition terminal, etc., etc. The outcome of such a test would be most valuable, it would be an education to the car builders, and it would be a means of reducing cost of car operation to an amazing extent.

## Garden Spaces Drawn

THE first official act of the Automobile Board of Trade in connection with the 1912 show at Madison Square Garden took place at 4 o'clock yesterday at headquarters, it being the drawing for positions at the show. In all 58 manufacturers drew for positions. The order of drawing was determined by the total value of cars manufactured by the different makers for the fiscal year up to June 30. This output was determined from the figures of the recent A. L. A. M. organization and by sworn statements from the different makers for their product from January 1 to June 30. First choice fell to the Buick Motor Company, who selected position 14 on the main floor. This is immediately in front of the entrance on the right. Second choice went to the Overland, who took position 15 on the center on the left. The order of the remainder in the oval in the center of the Garden floor was: E-M-F, Cadillac, Packard, Maxwell, Pierce, Chalmers, Hudson. The drawings beneath the gallery on the first floor in order were: Mitchell, Reo, Stoddard-Dayton, Oakland, White, Peerless, Locomobile, Oldsmobile, Stevens-Duryea, Winton, Pope-Hartford, Lozier and Franklin. Marmon could have had the last space on the main floor but preferred a position in the first balcony, this giving Stearns the last available place on the ground floor. The order of drawing for the first balcony was: Thomas, Everitt, Alco, Brush, Knox, National, Autocar, Premier, Elmore, Columbia, Jackson, Pullman, Haynes, Moline, Moon, Selden, Corbin, Lambert, American and Matheson. The drawing for Exhibition Hall on the ground floor was: Mercer, Case, Cartercar, Inter-State, Simplex, Amplex. The Speedwell had the preference of drawing before the Amplex, but preferred a position on the second balcony. The others in the second balcony in the order of drawing were: Garford, Ohio, Palmer & Singer, Marquette, Daimler, Atlas and McIntyre. These will occupy but one side of the balcony, the other side being given over to motorcycles. The usual space will be devoted to accessories. The show will be a duplication of last year, namely an exhibition for pleasure cars and accessories the first week and the second week devoted to commercial vehicles and accessories.

In the drawing nearly all of the companies were personally represented. Colonel George Pope was in charge assisted by M. L. Downs, secretary of the show.

## List of General Motors Holdings

DETROIT, MICH., Sept. 4—An interesting document recently filed at Lansing gives what is believed to be the first authentic list of factories comprising the General Motors group. The list is as follows: Buick Motor Co., Cadillac Motor Co., Olds Motor Co., Elmore Manufacturing Co., Cartercar Co., Northway Motor and Manufacturing Co.; Marquette Motor Co., Randolph Motor Car Co., Rapid Motor Vehicle Co., Reliance Motor Truck Co., Welch Co. of Detroit; Welch Motor Car Co., Champion Ignition Co., Jackson-Church-Wilcox Co.; Michigan Auto Parts Co.; Oak Park Power Co., McLaughlin Motor Car Co., Ltd., and the Weston-Mott Co.

## Ask for Glidden Changes

BY far the most important feature that came up in conjunction with the meeting of the National Association of Automobile Manufacturers yesterday was a recommendation from this organization to the Manufacturers' Contest Association that a change be made in the 1911 contest rules of the A. A. A. governing reliability runs. The recommendation was to the effect that the rules be immediately changed so that a grade 4 reliability contest can be held without the entrants being registered stock cars. This recommendation was made at the request of President Hooper, Counsel Terry, and Chairman Butler, of the American Automobile Association, and was made so that the present Glidden Tour can be competed for by unregistered cars. The recommendation will be considered by the Manufacturers' Contest Association at its meeting tomorrow. The voting members of the N. A. A. M. were generally favorable to the change. If the change is made it will allow many private owners to enter the tour with cars which are not registered. This change if made will only affect grade 4 contests, which penalizes for lateness at controls only and does not take into consideration penalties for work done on the road or final technical examinations.

Another important matter was the receiving a recommendation from a special committee of the Manufacturers' Contest Association, headed by Howard Coffin and Howard Marmon, on the question of the future of contests. The M. C. A. Committee brought up the matter of the national organization financing the contest board, the contest board being merely a body for the sanctioning of contests. The matter was immediately referred to the contest committee of the N. A. A. M., which committee will report the matter at the October meeting.

Philadelphia representatives presented to the N. A. A. M. the outline of plans for the organization of an insurance company solely for the control of automobile insurance, which would cover every form of accident, fire, theft, etc. The proposed organization of such a company is the outcome of the dissatisfaction in settling present motor car insurance claims. No definite action was taken in the matter. The majority of the stock would be held by car and accessory manufacturers. One feature of the policies would be that cars damaged by accident or fire would be repaired at the agency or factory of said car.

## Annual Round-Up of Studebaker Dealers

DETROIT, Sept. 4—The present series of excursions being conducted by the Studebaker Corporation's E-M-F Company factories have taken a greater scope in introducing maker and dealer than anything of its kind. During the past week the Studebaker dealers from the Central and Western South have been present for two days each, as guests of General Manager Flanders. They will be succeeded by other delegations this week, as follows:

Sept. 5, Philadelphia and Washington; Sept. 6, Chicago, Ill.; Sept. 11, Dallas and Oklahoma; Sept. 14, Kansas City; Sept. 18, Indianapolis; Sept. 21, Minneapolis; Sept. 25, Fargo; Sept. 29, Des Moines and Sioux Falls.



## Fast Time at Old Orchard

OLD ORCHARD, ME., Sept. 5—World's records were established at old Orchard Beach this afternoon. Unless there is some dispute over the length of the course—and there cannot very well be, for the A. A. A. has a certificate that it was of proper length—new marks have been set up for 25 miles and 50 miles.

In the 25-mile race (ten laps for the necessary distance), Louis Disbrow, in his special Pope-Hartford, nosed out Jack Rutherford in his National, in the last 500 feet of the route, and won in the remarkable time of 15:25—thought to be the record for the distance. The last event of the day, a race of 50 miles (20 laps of the course), was won by Rutherford, in his National, in 30.06 1-5, which, if correct, beats the old record by more than eight minutes.

The famous racers who have been at the three days' meet declared that Old Orchard Beach offers the best race course in the world. W. T. Kincaid, chairman of the contest committee of the Old Orchard Automobile Association, announced that there would be more races next year, earlier in the season, for three prizes aggregating \$3,000. Following is a summary of Tuesday's events:

Pos.	Car.	Driver	Time
	Stanley	L. F. N. Baldwin	:40
<b>Mile Exhibition Against Time</b>			
	Pope-Hartford	Louis Disbrow	3:58
<b>Five Mile Exhibition</b>			
	Pope-Hartford	Louis Disbrow	15:25
1.	National	John M. Rutherford	15:26
2.	Buick	G. C. Jessup	15:26 1/2
4.	Pope-Hartford	C. L. Bowler	15:36 1/2
5.	Interstate	Harry Endicott	15:39 1/2
<b>Twenty-Five Mile Free-for-All</b>			
<b>Match Race Ten Miles</b>			
1.	Cole "30"	V. A. Neilson	7:56 1/2
2.	Interstate	H. J. Habich	7:56 1/2
<b>Fifty-Mile Race, Free-for-All</b>			
1.	National	John M. Rutherford	30:06 1/2
2.	Pope-Hartford	Louis Disbrow	30:15 1/2
3.	Pope-Hartford	C. L. Bowler	30:40 1/2
4.	Interstate	Harry Endicott	
5.	Jackson Flyer	Harry Cohe	
<b>SUMMARY OF MONDAY'S RACES</b>			
<b>Special Match Race, Five Miles</b>			
Car.	Driver	Time	
1.	Cole 30	Henry J. Habich	8.04
2.	Chalmers-Detroit	N. A. Mitchell	8.56
<b>Exhibition, Five Miles for Record</b>			
	Pope-Hartford	Louis Disbrow	3.03
<b>Free-for-All, One Mile Time Trials, \$50</b>			
1.	Stanley Steamer	L. F. N. Baldwin	42 seconds
2.	National 40	John M. Rutherford	47 seconds
3.	Buick 17	G. C. Jessop	54 seconds
4.	Interstate	Harry Endicott	54 seconds
5.	Pope-Hartford	C. L. Bowler	57 seconds
<b>Class D, Free-for-All, Ten Miles, \$100</b>			
1.	National 40	John M. Rutherford	6.15
2.	Pope-Hartford	Louis Disbrow	6.23
3.	Pope-Hartford	C. L. Bowler	....
4.	Interstate	Harry Endicott	....
<b>Exhibition Mile</b>			
	Stanley Steamer	L. F. N. Baldwin	44 seconds

### The First Day's Races

The first day's races were thoroughly successful and well contested. In the ten-mile contest there was a tough fight for honors. "Jack" Rutherford's National 40 finally won out. He got the lead at the start and maintained it throughout the route, though he was hard pressed by Louis Disbrow in the Pope-Hartford. The time of the winner was 6 minutes and 15 seconds.

Old Orchard beach, in being laid out for races, presented some difficulties at first. The whole beach is fully six miles long, but at the west end there are rocks and in the middle is the famous Old Orchard steel pier. Pillars from this structure were removed and a good course, two and a half miles in a straight line, was provided. Over this the five-mile races and the ten-mile races were run and the mile races were pulled off with a straightaway course for the distance covered. It was thought at first that some accidents might result because of the passage under the pier, but there was not even a semblance of a mishap. The fact that it was a holiday attracted fully 50,000 people on the beach to witness the races. On the beach, the

crowd extended for the full length of the course. The Seventh Company of the National Guard, under command of Capt. Goodier, of Biddeford, did patrol duty, and aided in keeping the crowd back from the course.

It looked for a while, though, as if the races would be called off for the people got too near the course and simply would not move, but they were finally forced back to proper limits.

In the mile time trials Baldwin, in his Stanley steamer, covered the course in 42 seconds, which was the best time. Rutherford closely approached him with a 47-second mile.

The really best time of the day was made by Louis Disbrow, in his Pope-Hartford, in an exhibition five-mile event. He covered the distance in 3.03, which was at the rate of better than 98 miles an hour. Rutherford, in the ten-mile free-for-all, did the course at the rate of 96 miles an hour.

## Seventeen Start in Buffalo Run

BOLIVAR, N. Y., Sept. 6—Seventeen contesting cars made the start from Buffalo this morning on the first stage of the second annual reliability tour given under the auspices of the Automobile Club of Buffalo. Heavy showers last night made the roads out of Buffalo unspeakably bad and as the result few cars escaped penalty. The morning's run was through very hilly country and extra water and gasoline were required by the majority of the cars during the morning.

The run is scheduled for four days, each day's run ending at the parking station established on the spacious lot on Main street, just south of the Pierce-Arrow establishment. The outer mark on to-day's run is to Bolivar, N. Y.; Thursday, Dansville, N. Y.; Friday, Warren, Pa.; and Saturday, North Java, N. Y.

The tour is being run under the management of the Contests and Runs Committee of the Automobile Club of Buffalo, composed of Orson E. Yeager, chairman; Arthur W. Kreinheder, E. C. Sutton, I. N. Stewart, J. A. Murphy, Augustus H. Knoll and W. E. Blair.

There were nineteen entries, as follows:

Number	Car.	Driver
8	Everitt	J. W. Gardham
27	Paige-Detroit	J. E. McFadden
26	Warren-Detroit	J. S. Mohrhardt
21	Ford	G. Morton Wolfe
14	Ford	{ M. B. Leahy
12	Ohio	{ F. L. Rockelman
5	Cole "30"	E. A. Glaney
6	Lion "40"	E. A. Green
11	Schacht	H. L. Blomstrom
24	Oakland	{ E. W. Werick
20	Krit	{ C. H. Werick
29	Hupmobile	Harold Harwood
3	Flanders	Howard A. Bauer
4	Flanders	{ C. A. Almendinger
9	Flanders	{ M. R. Birk
1	Maxwell	B. W. Scott
2	Maxwell	T. R. Bell
10	Maxwell	G. M. Herron
28	Abhatt-Detroit	Charles F. Monroe
		E. G. Gager
		Thomas Costello
		Frank H. Denny

## Good Racing at Salem

SALEM, N. J., Sept. 4—The happy combination of perfect weather conditions and a holiday, served to attract a throng of 5,000 enthusiastic spectators from Philadelphia and South Jersey towns to-day to witness the automobile races conducted under the auspices of the South Jersey Motor Club, at the organization's Labor Day matinee meet on the half-mile track here.

Although many of the races were not blessed with an overabundance of entries, interest was sustained throughout the afternoon and the crowd was well repaid by some clever and daring driving. All races were run off as originally carded with the exception of Event No. 3, which went by the board by reason of the failure of one of the cars entered to put in an appearance. In two other events the issue was settled without a struggle, two out of the three cars in one failing to finish, owing to mechanical trouble, and in the other, containing but two entries, one dropping out before the finish, the winners triumphing in hollow fashion.

The event that stirred up the most enthusiasm and which cre-

ated the most excitement was the trial against time for five miles. The former record for a half-mile track in New Jersey was 6:45, established at the Mt. Holly track, Mr. Harvey Ringler piloting a Mercer car, clipped two and one-fifth seconds from the old mark, the watches catching him as 6:37 4-5 seconds. Ringler was also successful in the first event, a five-mile affair, his opponent, Bob Morton, driving a Kline Kar, being forced to drop out. Tire trouble seemed to pursue the Kline Kar throughout the afternoon, as for one cause or another it failed to finish in any of the events entered.

The Velie car maintained its fine work of Saturday last at Pottstown and won both of the races in which it was entered, J. David at the wheel. Vincent Padula, of Philadelphia, had an easy time capturing the second event, five miles, neither of his opponents, a Kline Kar and a Metz, being able to stick.

In the concluding race of the day, a handicap event, the Abbott-Detroit, with Vincent Padula at the wheel, and the Mercer car, Harvey Ringler driving, the finish was so close that the result is in doubt, there being little to choose between the two cars.

### A.A.A. to Boost Good Roads

NEW YORK, Sept. 6—At to-day's meeting of the Executive Board, American Automobile Association, the National Good Roads Board was authorized to arrange for a Federal Aid Good Roads Meeting to be held in Washington, D. C., in September. The matter will be entirely in charge of Chairman Diehl of the Good Roads Board.

The North Dakota State Automobile Association was admitted into membership with the A. A. A. It is made up of three clubs and 200 individual members. This makes a total of 40 State associations in the parent body with an aggregate membership of over 50,000. The Bannock County Club of Idaho, and the Greensborough and Winston-Salem Clubs were admitted.

The matter of the Glidden Tour was taken up. At present there are thirty-five entries in hand and it is expected that seventy-five will be received by the closing date. This tour is to be a good roads boosting proposition and the majority of the entrants are private citizens of the South. In order to make the run more popular it is understood the Manufacturers' Contest Association will recommend the abolition of the stock car technical examination in conjunction with this run. This is being done in order to allow many private owners of unregistered stock cars to enter the tour.

### Seven Clean Scores in Lake Tahoe Run

SAN FRANCISCO, Sept. 1—The hardest endurance run ever held in Northern California has just been completed. It was a four-day endurance test between this city and Lake Tahoe and return, a distance of 520 miles, a great deal of which is through the Sierra mountains, rising to a height of 7,000 feet. About two dozen cars took part in the run, but only fifteen of these were officially entered as contestants. Of these fifteen seven secured perfect scores, as follows: American "Fifty" driven by Stanley Gawne; Buick "26," driven by Claud McGee; Buick "30," driven by Fred E. Gross; Elmore "30," driven by Bruce W. Aurandt; Flanders "20," driven by Stanley Jonas; Franklin "18," driven by A. S. Chisholm (official pilot car); and Winton "Six," driven by Harry L. Owesney.

### Preparing for Port Jefferson Climb

Sixteen events will make up the program of the Port Jefferson hill climb, which is scheduled for Saturday, September 9. De Palma's Fiat, which holds the present record of the course—20.48—will not be in evidence, although there will be no dearth of fast cars among the competitors. The work of resurfacing the hill and banking the elbow turn has been in progress for some time, and the prospects for cutting a liberal slice off the present figures are considered excellent.

## Westcott Wins 200-Mile

COLUMBUS, OHIO, Sept. 3—A crowd variously estimated at between 25,000 and 28,000 attended the 200-mile automobile race held under the auspices of the Columbus Automobile Club at the Columbus Driving Park Sunday, September 3. The race was one of the most successful in the history of automobile racing in Ohio and several records on a dirt track were broken.

Lee Frayer in a Firestone-Columbus went one of the miles in 54 seconds flat, which is a record in a contest on a dirt track. The time of Harry Knight in a Westcott, who won the race handily, was 3:45.00 flat.

There were three cars which finished the 200 miles out of the eight starters. Jackson No. 2 car driven by Max Borst and entered by J. P. Adamson, the local Jackson dealer, finished in 4:15.00 flat, while Jackson No. 1 driven by John Borst, a brother of the other Jackson driver, finished just 1 minute later, the time being 4:16.00.

The starters in the race were: Jackson, driver John Borst, entered by J. P. Adamson; Jackson, driven by Max Borst, entered by J. P. Adamson; Cino, driver William Fritsch, entered by Haberer & Company; Ford, driver W. G. Lake, entered by Ohio Auto Sales Company; Marquette-Buick, driver Frank Lawwell, entered by Leyman Buick Company; Westcott, driver Harry Knight, entered by the Westcott Motor Car Company; Firestone-Columbus, driver Lee Frayer, entered by Lee Frayer; Cole, driver G. Morris and John Jenkins, entered by Cole Motor Car Company.

The race was a sweepstakes with the purse of \$1,000 divided into three moneys, viz., first money, \$500; second money, \$300; third money, \$200. In addition the winners of the first three places received valuable trophies in the shape of loving cups.

The start of the race was made at 1:40 p. m., with the cars going at an estimated speed of 30 miles per hour. The lead was at once taken by Leo Frayer in the Firestone-Columbus, who kept it until the eighty-sixth mile when the car skidded while making a curve and went through a fence. Frayer was pinned under the car and was taken out after some trouble. He was not seriously injured and is expected to be around in a few days. The car was put out of commission by the accident which cannot be accounted for by Frayer.

The Westcott car driven by Harry Knight then took the lead and held it until the end. The car was never in danger and was compelled to stop only twice during the 200-mile race. The first stop was made after the car had made 114 miles and was for gasoline and oil; another stop was made later for one tire.

The Cino, driven by William Fritsch, only made 14 miles before it was compelled to leave the track because of magneto trouble. At the end of the thirty-first mile the Ford car, driven by W. G. Lake, was compelled to leave because of trouble with the water cooling system. The Cole entrant, driven by John Jenkins was compelled to leave at the end of the seventy-third mile because of engine trouble.

The accident that put the Firestone-Columbus car out of commission occurred at the end of the eighty-sixth mile on a bad turn in the track. The Marquette-Buick when in second place at the end of the 198th mile threw a tire and skidded into the inside fence. Frank Lawwell had given away to William Fritsch and Ben Lawwell was acting as mechanic. The latter was thrown high in the air but escaped serious injury and Fritsch was not scratched at all.

The winner of the race, Harry Knight, made the sixth mile of the distance in 58 seconds flat, which was his fastest mile.

### 24-Hour Race Announced for Brighton

During the running of the races at Brighton Beach on Monday, it was announced that application had been made to the Contest Board for a sanction for a 24-hour race to be held on that track between September 23 and 30. According to the announcement ten entries have been made.



More than two-score automobiles at one of the checking stations of the 100-mile Farmers' Sociability Run, at Kalona, Ia.

### Farmer's "Sociability" Run

One of the greatest advantages of the auto on the farm is the sociability it affords, and the farmers are finding out that the automobile is fast doing away with the isolation and disadvantage of farm life. It is also encouraging the young folks to remain on the farm and putting a stop to the influx to cities.

In this connection, it is of interest to learn that forty-three farmers of Kalona, Iowa, have just completed what is said to be the first "Sociability" run ever held by farmer motorists. The tour covered 100 miles, starting at Kalona. The route led through Washington, Brighton to Richland and return. Not a single one experienced any mechanical trouble, which added greatly to the pleasure of the trip.

When it is remembered that these forty-three farmers all live in the same locality some idea is gained of the extent to which farmers are purchasers of automobiles. In this particular instance every car used in this run was the "Dreadnought" Moline.

### Transcontinental Truck Arrives on Coast

SAN FRANCISCO, Aug. 26—The first half of a most remarkable motor truck test was completed yesterday, when the Packard three-ton truck arrived here from New York. While this is not the first time that a motor truck has crossed the continent, it is the first instance that such a test has been made a day-to-day affair. The time of the Packard was forty-six and a half days from the time the big truck started from New York. The number of days that the Packard was actually on the road was forty-one, the other five and a half days being spent in the larger cities along the route.

The car is in charge of W. T. Fishleigh, body engineer of the Packard Motor Car Company. Accompanying him are E. L. Burnett and A. Haener, of the experimental department of the Packard Company.

### Small Fields at Gearhart Beach

TACOMA, WASH., Sept. 2—Over 2,000 enthusiasts witnessed the races at Gearhart Beach on August 26. In the first race a Locomobile, driven by C. A. Barstow, won, covering the distance in 5 minutes 26 seconds. D. C. Reynolds, in a Pierce-Arrow, was second. The only other entry failed to finish. Carl R. Gray, president of the Hill lines in Oregon, presented a cup to the winner.

Robert Bearce, driving a Marion, won the second race in 5 minutes and 48 seconds. George Crab, in a Warren-Detroit, was second, and F. W. Perkins, driving an Overland, third. The race was for the Astoria Centennial Cup.

The third race was a handicap event and was captured by

D. C. Reynolds in his Pierce-Arrow in 5 minutes and 30 seconds. C. A. Barstow, in a Locomobile, was second and Robert Bearce, driving a Marion, third. The Gearhart Hotel presented the winner with a cup.

The number of entries in the three races scheduled were not as many as the committee had anticipated.

### Velie Stars at Pottstown

POTTSTOWN, PA., Sept. 2—The annual fair of the Montgomery County Fair Association was brought to a successful termination to-day by an afternoon of automobile racing conducted by the South Jersey Motor Club, the meet attracting more than 5,000 persons.

Interest centered in the attempt to lower the existing record for the mile circular track of 1 minute 21-5 seconds, hung up by the Mercer car last year, Harvey Ringler driving. William Mullin turned the track, clipping 1 1-5 seconds from the mark, negotiating the circuit in 1.01.

The carded events were five and ten-mile races in which Philadelphia pilots shone. Notwithstanding the fact that rain had continuously fallen for the preceding week or more and the sun had not put in an appearance until Friday, the track was in fine shape and the average time of the winners good. The fastest time made during the day was in event No. 6, won by the Velie car in 5.26 1-5 for the five miles, while the slowest was in the second event, 11.57 for the ten miles being the time taken by the Mercer car driven by Ringler.

Practically the same cars and drivers will take part in the races at Salem, N. J., on Labor Day. Summaries:

Position.	Car.	Driver.	Time.
<b>Ten miles, 161 to 200 cubic inches</b>			
1.	Abbott-Detroit.	V. Padula	11:50
2.	Regal.	F. N. Snader.	12:34
3.	Metz.	H. B. Baker.	....
<b>Ten miles, 201 to 300 cubic inches</b>			
1.	Mercer.	Harvey Ringler.	11:57
2.	Klinekar.	Bob Morton.	12:58 1/2
3.	De Tamble.	G. H. Hambly.	....
<b>Ten miles, 301 to 450 cubic inches</b>			
1.	Velie.	J. W. Davis.	11:38 1/2
2.	Fiat.	Sig. Isenberg.	12:04
<b>Ten miles, 161 to 200 cubic inches</b>			
1.	Regal.	F. N. Snader.	....
2.	Metz.	H. B. Baker.	....
No race, cars called off at end of second lap.			
<b>Five miles, special match race</b>			
1.	Velie.	J. W. Davis.	5:26 1/2
2.	Klinekar.	Bob Morton.	5:31 1/2
<b>Special handicap race for winners; ten miles</b>			
1.	Velie (hdcp. 30 sec.)	J. W. Davis.	11:30
2.	Abbott-Detroit (hdcp. 1 min.)	V. Padula	11:57
3.	Simplex (scratch).	William Mullin.	....
4.	Regal (hdcp. 1 min. 6 sec.)	F. N. Snader.	....
1.	Klinekar (hdcp. 30 sec.)	Bob Morton.	5:33
2.	Abbott-Detroit (hdcp. 10 sec.)	V. Padula.	6:17 1/2

### Sued for Appropriating Gasoline

AKRON, OHIO, Sept. 4—Automobilists of Ohio and Michigan who have had occasion to ship their cars by boat either from Cleveland to Detroit or vice versa are up in arms over what they declare to be unfair treatment they have been receiving from the Detroit & Cleveland Navigation Company. When autos are run aboard D. & C. steamers at either end of the line the gasoline is of course drained from their tanks, in compliance with a marine fire insurance regulation. Arriving at the other end of the line an arbitrary rule is enforced, by which the boat company replaces only three gallons at the Cleveland end or five gallons at Detroit. Sometimes as much as twenty-five gallons are taken from tanks at the beginning of the run, and autoists have naturally felt that they had room for complaint, but their objections have thus far brought no revision of the rule. B. P. Foster, a Cleveland manufacturer and member of the Cleveland Automobile Club, who claims that on several occasions he was relieved of much more gasoline than was returned to him, has authorized his attorneys to begin suit against

the D. & C. Company for the difference between the gasoline taken and the gasoline returned, or its equivalent in money. It has been estimated that the company has already benefited to the extent of thousands of gallons of gasoline by its rule.

### Big Month for Winnipeg Motorists

WINNIPEG, MAN., Sept. 2—The automobile racing enthusiasts of Western Canada will have their speed hunger appeased on Saturday, September 16, when the annual Fall race meeting of the Winnipeg Automobile Club will be held on the mile track at Kirkfield Park.

In addition to the track races the endurance run to determine next year's holder of the Oldsmobile trophy will be held September 29-30. This contest is held over a central Manitoba course of 455 miles, which includes roads of every variety. Some forty starters are expected to compete.

The race card for the Kirkfield Park meet includes the following events:

- Ten-mile race, for stock cars up to 160 inches piston displacement.
- Ten-mile race, for stock cars from 161 to 230 cubic inches displacement.
- Ten-mile race, for cars from 231 to 300 inches displacement.
- Ten-mile race, for stock cars, 301 inches displacement and over.
- One-mile open attempt for record.
- Five-mile open race for stripped cars.
- Dunlop trophy race, 25 miles. Open to any car or driver resident in the province.
- Ten-mile open race for stripped cars.

### Records Stand at Scranton

SCRANTON, PA., Sept. 5—Five efforts to break the record of 1.08 for a mile on a half-mile track failed at the Minooka Driving Park yesterday, Ralph De Palma making the trial twice, and R. A. Ammerman, Eugene Cusick, and Willie Haupt each once.

De Palma made the best time in his giant Simplex, a mark of 1.11 being credited to him. Two accidents marked the afternoon's sport. Eugene Cusick, of Scranton, in his Buick, driving in the five-mile, non-stock, class "C" free-for-all against De Palma and Haupt, had a narrow escape from death when he collided with the fence at the upper turn. A fence rail pierced the radiator.

Harry Kaufman, in a Buick, in the first event, two miles, non-stock, Class "C," likewise ran into the fence.

A crowd of 5,000 witnessed the races, which were under the auspices of the Scranton Racing Association. Summaries:

Pos.	Car.	Driver.	Time.
<b>Event No. 1—Two Miles</b>			
1	Buick	Ralph Ammerman	2:57
2	E-M-F	William Krise	
<b>Event No. 2—Three Miles</b>			
1	Mercer	Ralph De Palma	4:30
<b>Event No. 3—Three Miles</b>			
1	National	Willie Haupt	4:09½
2	Buick	Tom Jacobs	
<b>Event No. 4—Trial to Break Mile Track Record on Half-Mile Track Simplex</b>			
		Ralph De Palma	1:11
<b>Event No. 5—Five Miles</b>			
1	Mercer	Ralph De Palma	7:54½
2	Buick	Ralph Ammerman	
3	Buick	David Birtley	
<b>Event No. 6—Exhibition Mile</b>			
	Buick	Eugene Cusick	1:21
<b>Event No. 7—Amateur, Three Miles</b>			
1	Buick	Dr. E. F. McGinty	4:41½
2	Buick	Joe Willis	
<b>Event No. 8—Non-Stock, Class C, Free-for-All, Five Miles</b>			
1	Simplex	Ralph De Palma	6:39
2	National	Willie Haupt	
<b>Event No. 9—Exhibition Mile</b>			
	Buick	Ralph Ammerman	1:20½
<b>Event No. 10—Non-Stock, Class E, Free-for-All Handicap, Five Miles</b>			
1	Simplex	Ralph De Palma	
<b>Event No. 11—Exhibition Mile</b>			
	National	Willie Haupt	1:16½
<b>Event No. 12—Non-Stock, Class C, Free-for-All Handicap, Three Miles</b>			
1	Simplex	Ralph De Palma	3:41½
2	National	Willie Haupt	
3	Buick	Ralph Ammerman	
<b>Event No. 13—Exhibition Mile</b>			
	Mercer	Ralph De Palma	1:17½

### Record Crowd at Amarillo

AMARILLO, TEX., Sept. 5—The two-day race meet came to a close this afternoon in a highly sensational manner, when Carl Reeves, of Midland, Texas, driving a National "40" wrecked his car while going at a rate somewhat more than 70 miles an hour, caused by striking a soft earth roll at the inner line of the track. The machine was torn almost part from part, but one wheel retaining its spokes. The driver was thrown entirely across the track, sustaining a scratched elbow and bruised hip.

The first race of the afternoon was thirty miles, won by Staver-Chicago, driven by Nikrent, in 28 minutes and 27 seconds; second, Staver-Chicago, driven by Monckmeier, 28 minutes, 43 seconds; third, E-M-F, driven by Johnson, 30 minutes and 36 seconds; fourth, Cadillac, driven by Mullins, 30 minutes 56 seconds.

The second race, sixteen miles, was won by the E-M-F, driven by Johnson; time, 15 minutes and 55 seconds.

The 100-mile race was won by the National "40," driven by Wilcox; time, 96 minutes 56 seconds; second, Staver-Chicago, driven by Monckmeier, 103 minutes 15 seconds.

The 50-mile event went to the National "40," driven by Wilcox; time 46 minutes 59 seconds; second, Marmon, driven by Johnson. It was in this race that Reeves so narrowly escaped death.

On the first day the first event of twenty miles was won by the E-M-F 30, driven by Reeves, in 20 minutes 15 seconds, the Marion, driven by Day, finished second, and the Buick, driven by Triplet, third.

The second race, thirty miles, was won by Staver-Chicago, driven by Monckmeier, in 29 minutes and 6 seconds, with Staver-Chicago second and E-M-F, driven by Reeves, third.

The fourth race, at fifty miles, was won by a National 40, driven by Reeves, in 44 minutes and 37 seconds, with National 40, H. E. Wilcox, second.

### Setting Dates for Show Banquets

Dates for the big show banquets are being made and already it has been announced that the annual dinner of the Motor and Accessory Manufacturers will be held on the evening of Thursday, January 11, at the Waldorf-Astoria. A big attendance is already assured.

Tentative plans are also in process of formation with regard to holding a big combined banquet of the exhibitors and officers of the Automobile Board of Trade show at the Garden and of the National Association of Automobile Manufacturers show at the Palace. The function will probably be staged at one of the big uptown hotels and the date will probably be Tuesday, January 9.

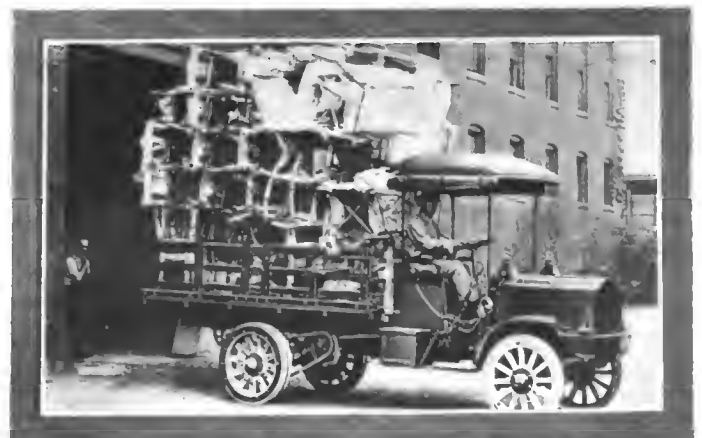

Showing the 1½-ton, 26.4-horsepower Packard truck delivering a huge load of furniture

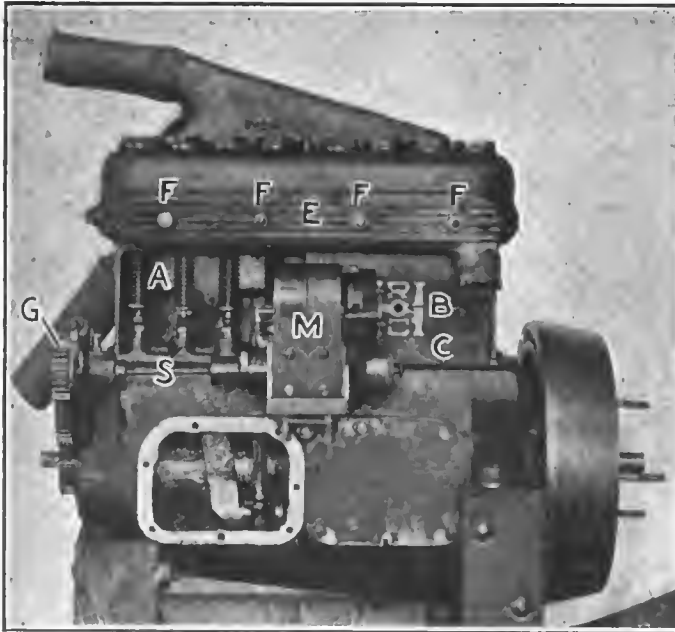

Fig. 1—Exhaust side of the motor with crankpit cover removed

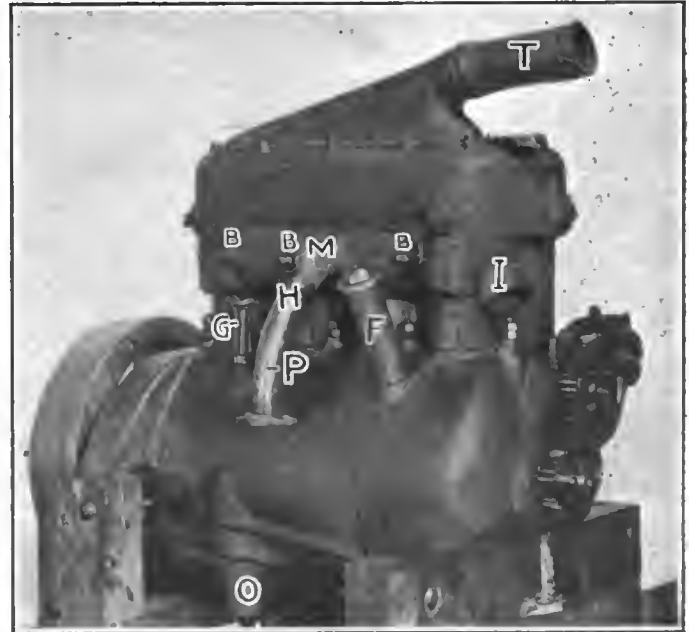

Fig. 2—General view of the right-hand side of the motor showing intake

## New Entry to Gasoline Field

### Hupp Corporation to Build Cars of That Type

*A runabout type of automobile is now being manufactured by this concern, which has been known formerly by its activity in the electric field, through its production of the Hupp-Yeats. Other types of body will be added to the line as the business develops, and the cars produced will be known as the R. C. H., after the initials of the president of the corporation, R. C. Hupp.*

THE announcement made by the Hupp corporation, of Detroit, Mich., during the first annual convention of this concern, brings to light the interesting fact that a new gasoline car known as the R. C. H. is about to find its way on the market. Heretofore this corporation has been known by the production of the Hupp-Yeats electric, to which it had confined its efforts.



Fig. 3—Showing the finished vehicle, known as Model F

It has been arranged at present to manufacture but one model—that being of the runabout type—and to add others as the business increases. This car will be known as Model F and has a rating of 22-horsepower, the body being of the completely enclosed torpedo type, with a seating capacity of two and a rear platform large enough for a tool box and a double rumble seat. The wheel base is 86 inches, the tread 56 inches and the tires 30 by 3 inches. The steering wheel is on the left and the change gear lever in the center, so that the car can be entered from either side. There is not any emergency brake lever; the gearbox is a unit with the rear axle.

The motor is of the long-stroke type, having a bore of three and one-quarter inches and a stroke of five inches; this is a ratio of 1 to 1.54. The cylinders are cast en bloc. The crankshaft revolves on two bearings, and the valve action, including the timing gears, is completely enclosed. In Fig. 1 the exhaust side of the motor is shown with one of the valve cover plates C removed. The action may be readily inspected by removing the bolt B, which holds this cover in place, and the crankpit may be examined by removing the inspection cover D. The exhaust manifold E is provided with air cooling flanges, and is held to the cylinder casting by means of four through bolts F, which terminate in bosses in the inner casting. The magneto M is driven by the shaft S, which is rotated by and connected to the gear G.

On the right side of the motor, Fig. 2, the carburetor is seen to be fitted within the base casting, the object being to preheat the mixture to insure vaporization. The short intake pipe P



is connected to the manifold M at H, the manifold being held to the cylinder casting by means of three studs, B. On this side of the engine the oil filler pipe F and the oil level glass G are located.

The cooling system is of the thermo-siphon type, with ample water jackets and fan in the flywheel. The intake is at I and the outlet at T. The radiator has a height of 23 inches and a width of 24 inches.

The lubrication is effected by means of the circulating splash system, the oil being maintained at constant level and circulated by means of a pump, the position of which is indicated by O, Fig. 2. The oil reservoir is in the lower part of the crankcase.

The clutch is of the cone type G, Fig. 5, with a self-contained thrust and an adjustable, grease-tight universal joint of hardened steel. A short shaft with a universal joint at each end connects the clutch with the forward end of the propeller shaft within the torsion tube, a considerable change in alignment being allowed by these joints. The propeller tube P is supported at the rear by the gearbox.

The gearset is of the three-speed, selective, spur-gear type, mounted on roller or plain bearings as specified by the purchaser. The gears are of chrome vanadium steel, and are hardened to prevent wear. The jackshaft and pinion shaft are of the same material as the gears. Upon the pinion shaft are mounted the sliding gears, which are held in position by four integral keys. The gearbox is divided vertically, so that the gears and shafts may be removed by simply unbolting the case. The rear half is integral with the axle housing.

The rear axle is of one-piece construction, with a cap at the rear which permits of the removal of the differential. Roller bearings support the differentials at either side and the thrust is taken by two ball bearings. The pinion and bevel gear are adjustable in both directions.

The steering gear, shown in Fig. 4, of the irreversible worm-sector type, is mounted on the left side of the frame. The steering wheel is 16 inches in diameter. The post is enclosed in a stationary black enameled tube. The right pedal R operates the external brake and the left pedal first disengages the clutch and then by a continuance of motion applies the internal brake, a slight forward motion of this pedal locking it in any desired position.

An accelerator pedal controlled by the right foot regulates the carbureter, and an adjustment just above the pedal determines the lowest speed possible when the foot is removed. The two brake rods extend from the control levers to the equalizers, located back of the axle, through the center of the chassis. This gives a concealed braking arrangement. The brake drums are 10 inches in diameter and 1 1/2 inches wide.

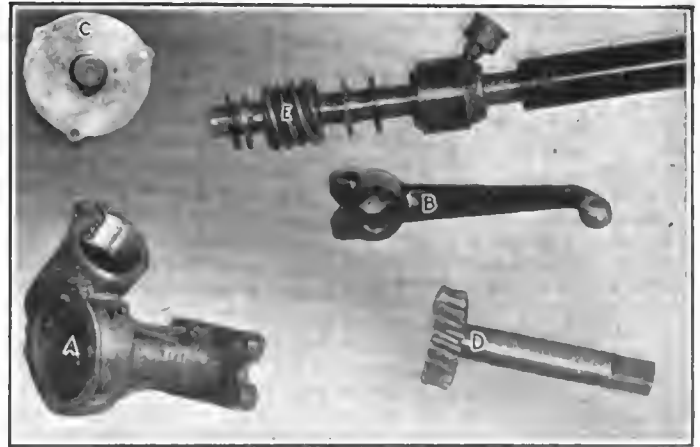

Fig. 4—Steering details: A, box; B, drop arm; C, cover; D, sector; E, shaft and worm

The front springs, 33 inches in length, one and one-half inches in width, are of the semi-elliptic form and are nearly flat. The rear springs, one and one-fourth inches in width and 37 inches in length, are of the elliptic style, tilted at the top toward the rear and hang under the axle. The passenger weight is well forward of the rear axle and the springs are mounted upon swivel seats to allow freedom under all possible conditions.

The equipment of the car is illustrated in Fig. 3, which shows the finished vehicle. It includes top, windshield, three oil lamps, two gas lamps, generator, horn and tool kit.

### Tire Pointer for the Automobilst

A motorist may find that an inner tube has been injured and perhaps ruined from no apparent cause. Upon examination small holes will be found in its surface, the only logical reason for their presence being apparently poor tube material. This, however, is seldom the cause, says a Michelin expert, the real trouble lying with the motorist. He has carelessly fitted the tube allowing small particles of mud and dirt to enter the envelope, the air pressure from within the tube and the external pressure combining to grind the foreign matter into the tube.

When fitting a tire it is not enough to simply clean the envelope and tube. Care should be taken to admit no mud or sand during the operation. The tire levers should not be left lying on the ground as they will collect dirt which may find its way into the envelope.

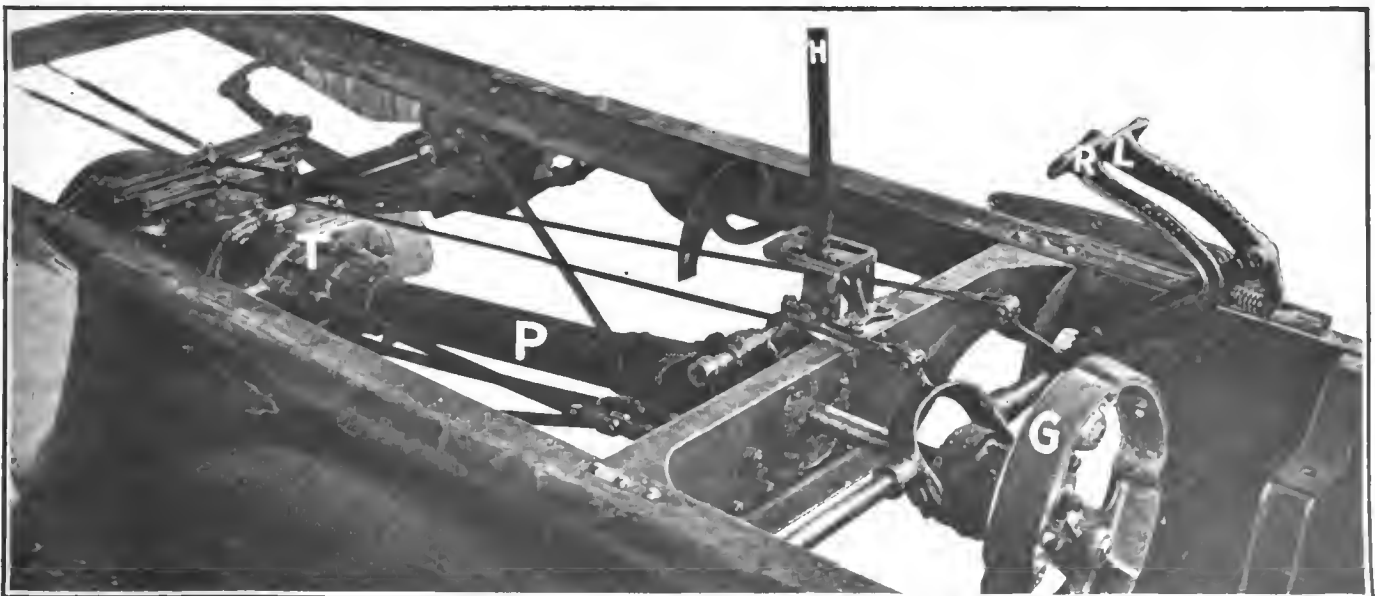

Fig. 5—View of rear end of chassis, showing clutch and transmission



**CHRISTCHURCH, N. Z.**—New Zealand's latest dreadnought, illustrated above, is built in this country by the Willys-Overland Company, of Toledo. The squadron of Overland cars that are following the dreadnought are also products of the same factory. The picture, which was taken during the carnival procession in Christchurch, represents a single shipment of Overland cars consigned to the New Zealand Farmers' Co-operative Association.

**LOUISVILLE, KY.**—The Wilder Motor Car Company has acquired the agency for the Everitt car in Kentucky.

**KENOSHA, Wis.**—Benjamin F. Windsor, president of the Windsor Spring Company, died last week at the age of 52 years.

**INDIANAPOLIS, IND.**—The Finch & Freeman Auto Company, which handles the Auburn, De Tamble, Clark and Richmond cars, has moved to 519 North Capitol avenue.

**WASHINGTON, D. C.**—Pending the selection of a salesroom in the down-town section, the Wilson Company, which handles the Cole and Krit lines, has taken temporary quarters at 1018 Connecticut avenue, N. W.

**BOSTON, MASS.**—E. P. Blake, who handles the McIntyre trucks, is dickering for the Corbin agency which was recently relinquished by the White, Ware & Leatherbee Company. Mr. Blake has also added the Blake car to his line.

**MILWAUKEE, Wis.**—Al. Reeke has succeeded A. W. Shattuck as sales manager of the local branch of the Thomas B. Jeffery Company. His territory will include, besides Milwaukee, practically all of Wisconsin and Upper Michigan.

**PHILADELPHIA, PA.**—The Gawthrop & Wister Company has recently secured the agency for the Brush car in the Quaker City.

**MILWAUKEE, Wis.**—The Smith-Hoppe Auto Company has completed arrangements for handling the Oakland car in Milwaukee and vicinity.

**AKRON, OHIO.**—The Miller Rubber Company has bought attractive land on the Manchester road in Kenmore, near here, to give room for factory expansion.

**INDIANAPOLIS, IND.**—One hundred employees of the Maxwell-Briscoe Motor Company have purchased 26 acres of land at Newcastle, Pa., upon which they will build cottages for their own use. The price paid for the land was \$500 an acre, the entire amount having been subscribed by the factory employees.

**RACINE, Wis.**—The Mitchell-Lewis Motor Car Company has filed articles of incorporation for four branch houses, at Seattle, Atlanta, Kansas City, and Philadelphia. The capital stock of each of the companies is \$10,000, and the incorporators in each instance are the same—C. A. Armstrong, G. V. Rogers and F. L. Mitchell.

**BOSTON, MASS.**—The Jackson car will hereafter be handled in the Hub through the agency of a factory branch, a company having been incorporated under the title of the Jackson Motor Car Company, of Massachusetts, with H. A. Matthews, treasurer of the Jackson Company in Michigan, as president. M. H. Bates, who formerly handled the car in Boston and Brockton, has been made treasurer, and J. L. Judd secretary and general manager. Ira Russell, formerly foreman of the Jackson factory, will have charge of the repair department.

**BOSTON, MASS.**—The Lowe-Howard Company, agent for the Krit and Correja cars, is preparing to give up the motor business. When the stock is disposed of the company will dissolve. The Krit line has been taken on by Willard M. Jenkins, who handles the Mitchell and Abbott-Detroit, in Boston.

**OMAHA, NEB.**—On account of the large number of Omaha dealers who desire to exhibit their cars at the Nebraska State Fair, the third annual endurance run of the Omaha Motor Club, which was originally scheduled for September 6-9, from Omaha to North Platte and return, a distance of 750 miles, has been postponed for a week, the new date being September 12-15.

**FINDLAY, OHIO.**—There is some trouble in conjunction with the present receivership of the Norwalk Motor Company. H. L. Stewart, who was appointed receiver by Judge Lee, has been succeeded by A. J. Schurr, of Cleveland, who was appointed by Judge Killits, at the instance of certain creditors. Some of the stockholders are now endeavoring to have Mr. Schurr removed and Mr. Stewart reappointed.

**LOUISVILLE, KY.**—Kentucky and Tennessee automobile dealers—120 strong—boarded a special Pullman train last Wednesday and went to Detroit where they were the guests of the Studebaker Corporation for two days. They made merry at luncheons, dinners, theatre parties, automobile rides and excursion trips and inspected the E-M-F and Flanders factories. W. W. Beeson, of this city, was in charge of the Kentucky delegation, which numbered fifty-four. The remainder of the dealers were from Tennessee and in charge of E. H. Jacoby, the Studebaker representative at Memphis.

WINNIPEG, MAN.—Last week 202 orphans of Winnipeg were treated to their annual automobile ride by members of the Winnipeg Automobile Club. They enjoyed a full day's outing with picnic and a programme of juvenile sports thrown in. Sixty cars were donated for the occasion.

BOSTON, MASS.—The Boston Automobile Dealers' Association is out with a booklet containing its preliminary announcement of the Tenth Annual Show, to be held in that city during the week of March 9-12, 1912. The booklet contains the rules and regulations governing the application for and allotment of space, including floor plans of Mechanics' Building and the necessary blanks.

INDIANAPOLIS, IND.—The Indianapolis Trade Association will make its ninth trade extension trip September 26 and 27. A special train will be used and about 150 members of the association and a brass band will make the trip, visiting retail dealers and distributing advertising matter. On the evening of the 26th the Fort Wayne Commercial Club will be host for the party. Places to be visited include Royerton, Shideler, Eaton, Hartford City, Montpelier, Keystone, Poneto, Bluffton, Kingsland, Ossian, Fort Wayne, Decatur, Monroe, Berne, Geneva, Briant, Portland, Ridgeville, Winchester, Lynn, Fountain City and Richmond.

CINCINNATI, O.—The second establishment representing Cincinnati automobile interests will soon be in operation in Canada—the pioneer having been the Schacht Company. The invader this time is the Ohio Motor Car Company, whose president and general manager, Charles F. Pratt, is now in Canada on a tour of inspection. He will probably locate and effect arrangements for the new plant to be in active working order in the very near future. Vice-President Schafer confirmed the report in regard to the mission of President Pratt and stated it had become almost a necessity by reason of the large and increasing Canadian business of the company.

NEW YORK CITY—The new United States Rubber Company building, now being erected at Broadway and Fifty-eighth street, was projected primarily to afford adequate quarters in a convenient uptown location for the main offices of the United States Rubber Company, as well as selling space in the automobile district for the United States Tire Company. The latter will occupy the store, with storage space beneath, while the United States Rubber Company will occupy the upper portion of the building.

The arrangement of offices is such that any number of offices may be thrown together, en suite, so as to meet any possible demands for floor space.

The construction of the building is in accordance with the best present day practice and particular attention has been paid

to the methods of fireproofing. The foundations of the building are fully water-proofed.

The mechanical equipment of the building includes complete independent heating plant with vacuum circulation, complete standpipe equipment for fire protection, vacuum cleaner plant for the entire building and electrically operated elevators of the gearless traction type.

Each floor contains approximately 6,300 square feet, if undivided. Subdivided, each floor provides seventeen offices, varying from the smallest single office of 280 square feet to the largest single office, 630 square feet.

## Automobile Incorporations

### AUTOMOBILES AND PARTS

ALBANY, N. Y.—Mobawk Valley Automobile Co.; capital, \$5,000; to make automobiles. Incorporators: Wm. E. Milbank, Agnes G. Waldron, Frank S. Weis.

COLUMBUS, OHIO—Toledo Annealing Charging Truck Mfg. Co.; capital, \$10,000; to manufacture freight automobiles. Incorporator: John J. Blum.

DETROIT, MICH.—Lozier Motor Co., increased its capital from \$2,000,000 to \$3,000,000.

GROVE CITY, PA.—Bessemer Motor Truck Co.; to manufacture automobile trucks. Incorporators: I. N. Lewis, J. E. Marquis, E. J. Fithian, L. M. Monroe, A. N. Allen.

HACKENSACK, N. J.—American Automobile Co. of Philadelphia; capital, \$50,000; to build motor cars. Incorporators: Ralph D. Earle, Geo. M. Brewster, John R. Ramsey, Wendell J. Wright.

HENDERSON, N. C.—Corbitt Automobile Co.; capital, \$250,000; to make automobiles. Incorporators: R. J. Corbitt, D. Y. Cooper, J. B. Owen.

SYRACUSE, N. Y.—Entries for the second annual Watson Cup run are pouring into the office of the Automobile Club of Syracuse, assuring the promoters that a record field will get away in the tour to Koenig's Point next week in competition for the handsome silver goblet presented to the club by B. F. Watson. The contestants are to leave the city at 8:30 a. m., driving to Koenig's Point, on Owasco Lake, where dinner will be served. The committee will award the \$100 trophy to the contestant coming nearest the secret time. The club also offers a silver trophy to the woman driving her own car who comes nearest to the secret time.

INDIANAPOLIS, IND.—Fisher-Gibson Co.; capital, \$50,000; to manufacture automobiles and accessories. Incorporators: Carl G. Fisher, Cecil E. Gibson, Will J. Dobyns.

JERSEY CITY, N. J.—Marquette Co.; capital, \$10,000; to manufacture automobile motors. Incorporators: B. S. Mantz, H. A. Black, John R. Turner.

LANSING, MICH.—American Motor Castings Co.; increased capital from \$200,000 to \$250,000.

MARTINSBURG, W. VA.—Norwalk Motor Car Co.; capital, \$300,000; to manufacture and sell automobiles. Incorporators: F. A. Minor, Gray Silver, S. P. Hopkins, H. L. Alexander, T. W. Martin, G. W. McKown, Leon H. Ware.

NEWARK, N. J.—E-M-F and Flanders Newark Sales Co.; capital, \$10,000; to sell pleasure cars.

NORFOLK, VA.—Coburn Motor Car Co., Inc.; capital increased from \$10,000 to \$50,000.

PITTSBURGH, PA.—Lang Motor Truck Co.; capital, \$25,000; to build freight automobiles. Incorporators: Edward L. Atkinson, Elias Lang, Rupert L. Border.

PORTLAND, ORE.—Braly-Dubois Auto Co.; capital, \$5,000; to handle automobiles. Incorporators: J. C. Braly, D. S. Dubois, Russell E. Sewall.

### AUTOMOBILE GARAGES, ACCESSORIES, ETC.

AKRON, OHIO—Standard Tire Protector Co.; capital, \$50,000; to make tire protectors. Incorporators: H. M. Coulter, B. O. Barber, O. J. Ballender, D. J. Kooneo, H. A. Lane.

ATLANTA, GA.—Mitchell Motor Co.; capital, \$10,000; to sell automobiles. Incorporators: C. A. Armstrong, G. V. Rogers, F. L. Mitchell.

CHARLESTON, S. C.—King Automobile & Repair Co.; capital, \$5,000; to buy, sell and repair motor vehicles. Incorporators: W. A. King, S. B. King, Jr., R. M. Lofton.

CINCINNATI, OHIO—Hayes & Havons Co.; capital, \$15,000; to operate a garage and rent automobiles. Incorporators: Gus L. Hayes, Geo. C. Kuhn, C. F. Havons, Louis M. Pink, Leo. R. Wise.

CLEVELAND, OHIO—Eagle Lubricant Mfg. Co.; capital, \$25,000; to make lubricating oils and grease. Incorporators: Cbas. F. Maybery, James Grabam, F. M. Potter, J. R. Ferguson, Oscar L. Tafe.

DAYTON, OHIO—Air Friction Carbureter Co.; increased capital from \$10,000 to \$20,000.

KANSAS CITY, MO.—Mitchell Motor Co.; capital, \$10,000; to sell automobiles. Incorporators: C. A. Armstrong, G. V. Rogers, F. L. Mitchell.

LIMA, OHIO—Lima-Overland Co.; capital, \$10,000; to sell automobiles and accessories and conduct a garage. Incorporators: Samuel Roeder, Howard W. Peers, George E. Bayley, Leo Roeder.

NEW ORLEANS, LA.—Kreber Auto Co.; capital, \$10,000; to sell automobiles. Incorporators: Charles Kreber; Bertha Kreber.

PHILADELPHIA, PA.—Mitchell Motor Co.; capital, \$10,000; to sell automobiles. Incorporators: C. A. Armstrong, G. V. Rogers, F. L. Mitchell.

PITTSBURGH, PA.—Mutual Wind Shield Co.; capital, \$25,000; to make wind shields and accessories. Incorporators: A. J. Kraber, Geo. F. Ferrier, Lorry Poffenberger.

PORTLAND, ORE.—Auto Painting & Exchange Co.; capital, \$25,000; to do a general business in automobiles. Incorporators: John Dumbell, Winnie Fleetwater, Henry O. Proebstel.

SEATTLE, WASH.—Mitchell Motor Co.; capital, \$10,000; to sell automobiles. Incorporators: C. A. Armstrong, G. V. Rogers, F. L. Mitchell.

ZANESVILLE, OHIO—Zanesville Central Delivery Co.; capital, \$10,000; to conduct a delivery business. Incorporators: E. B. Wadley, H. L. Garrett, B. V. L. Slack, William A. Frost, S. H. Sturts.



United States Rubber Company building now being erected in New York City

## OF INTEREST to the INDUSTRY

**PHILADELPHIA**—The United States Motor Company has purchased the salesroom and service building at 216-218-220 North Broad street, formerly occupied by the Packard Motor Company. The building is one of the show places of the automobile trade of Philadelphia. Immediate possession will be taken by the United Motor Philadelphia Company, which is the Quaker City branch of the United States Motor Company. It will become the home of the Columbia-Knight and Maxwell cars as well as Sampson freight and delivery motors. All departments will be enlarged, furnishing room for all the models sold by the branch. The floor space will be four times as great as in the present location at 207 North Broad street. The enlargement of all departments will be made immediately and a full line of parts for all the company's cars will be carried in stock in a spacious parts department. The repair department will embody a main shop 200 x 50 feet, and another floor of equal size will be available for the storage of finished repair work. The maintenance of Sampson trucks will be conducted on another floor.

**ZIONVILLE, IND.**—Marion & Stutz will represent the Cole line in this city during the coming twelvemonth.

**PITTSFIELD, MASS.**—The Cortland Motor Wagon Company is removing its plant from Cortland, N. Y., to this city.

**SYRACUSE, N. Y.**—The J. H. Valentine Motor Car Company has taken on the Syracuse agency of the Paige-Detroit.

**EVANSVILLE, IND.**—Harry P. Mammen, of this city, has been appointed sales manager for Cole cars in Eastern Indiana and Western Ohio.

**ST. LOUIS, MO.**—The General Motor Car Company, 3952 Olive street, has been appointed Missouri distributor for the Cole car for 1912.

**WASHINGTON, D. C.**—An agency for the Stutz car has been established in this city by J. H. Ebersole at 1521 Fourteenth street, N. W.

**READING, PA.**—The Park Garage, which handles the Cole line in this city, has moved to new quarters at Eighteenth street and Perkiomen avenue.

**CLEVELAND, OHIO.**—The Standard Welding Company will open a branch office in the Ford Building, Detroit, Mich., September 11, with C. E. Miller in charge.

**DETROIT, MICH.**—The district representation of the Westcott cars in Michigan, Northern Indiana and Northern Ohio, will in the future be looked after by A. K. McCluny, with headquarters in this city.



Philadelphia home of the United States Motor Company

**LOUISVILLE, KY.**—The United States Tire Company will open a wholesale branch at 904-906 South Third avenue, with H. G. Moesta in charge.

**MILWAUKEE, WIS.**—The Schreiber Motor Car Company has been appointed general distributor of the Stegeman motor truck for Wisconsin and the Central Western States.

**MILWAUKEE, WIS.**—G. P. Hewitt, former manager of the Buick branch in this city, has been appointed district manager of the Westcott Company in Minnesota, Wisconsin and Iowa.

**TACOMA, WASH.**—George A. Stewart, formerly sales manager of the Pacific Car Company, has been appointed district manager for the Everitt Northwest Company, with headquarters in Tacoma.

**DES MOINES, IA.**—H. B. Groves, manager of the United Motors Des Moines Company, has resigned. He will devote his interest to the Interstate Supply Company, of Sioux City, of which he is owner.

**NEW YORK CITY.**—C. F. Splitdorf has opened a branch office in Kansas City, Mo., at 1823 Grand avenue. E. A. Kelley, who for some years has had charge of the firm's San Francisco business, will be at the head of the new branch.

**SEATTLE, WASH.**—C. G. Arnold, formerly connected with the New York agency of the Pope-Hartford, and with the Keats Auto Company, of Portland, Ore., has become manager of the Olympic Motor Car Company, of Seattle.

**INDIANAPOLIS, IND.**—R. P. Henderson, formerly sales manager of the Parry Buggy Company, has assumed the vice-presidency of the Henderson Motor Sales Company, general agents for the Cole. Mr. Henderson is a brother of Charles P. Henderson, general manager of the Henderson Company.

**LOUISVILLE, KY.**—The Racine Auto Car Company, formerly located at 647 South Fourth avenue, has moved its salesroom and offices to Third avenue near Breckenridge street.

**INDIANAPOLIS, IND.**—The Empire Motor Car Company has decided to invade Japan, an agency having been established in that country with T. Laffin, of Yokohama, in charge.

**PHILADELPHIA, PA.**—The Jackson-Marion Sales Company, at 634 North Broad street, has closed a contract for the local representation of the Stutz car for the coming year.

**TACOMA, WASH.**—Having recently acquired the agency for the White cars in Southwestern Washington, J. F. Hickey has established the White garage at 750 South C street.

**ATLANTA, GA.**—The Long-Henderson Company, 226 Peachtree street, Cole distributors in the southeastern section of the United States, has changed its name to the Cole Motor Company, of Georgia.

**CLEVELAND, OHIO.**—The actual working force of the Peerless Motor Car Company now numbers over 2,200, not including office employees or executives. A number of departments are working day and night.

**BROOKLYN, N. Y.**—E. J. Montigny has closed a contract with the Abbott Motor Company of Detroit, Mich., as wholesale and retail distributor for the city of Brooklyn and Long Island. He has organized a company for the purpose of carrying on the business.

**RICHMOND, IND.**—The Westcott Motor Car Company has announced that the selling arrangements with the Henderson Sales Company of Indianapolis have been cancelled. Henceforth the sales of the Westcott will be handled from the factory, and an independent sales organization will be built up throughout the country.

**BOSTON, MASS.**—Morton H. Luce, former manager of the Boston Velie branch, will shortly assume the management of the company's Chicago branch, handling the sale of pleasure cars and trucks in Illinois, Wisconsin, Michigan, Indiana and Ohio. The Velie interests in New England will in the future be looked after by Harold D. Bornstein of the Boston branch.

**DETROIT, MICH.**—The Universal Motor Truck Company has appointed the Lindsay Motor Company, 3327 Locust street, distributors for the St. Louis territory. The Hodgins-Fosdick Motor Company, Inc., Chalmers dealers at Spokane, Wash., have taken on the agency for these trucks in Eastern Washington. Thomas Black will look after the interests of these vehicles in Winnipeg, Manitoba.





**CAR TRUCK**—Being a form of suspension for motor vehicle loads.

2. The patent covers a car truck (Fig. 1) having a frame with side bars, links pendant from the side bars and rigidly connected therewith, springs supported by said links, a cross bolster, longitudinally extending equalizing bars and means for pivotally supporting the bolster on the equalizing bars and the latter on the springs.

No. 1,000,480—To Walter S. Adams, Philadelphia, Pa., assignor to the J. G. Brill Co., Philadelphia, Pa. Granted August 15, 1911; filed May 19, 1909.

**CARBURETER**—Containing such features as prevent flooding of the carbureter while operating.

2. This patent relates to a type of carbureter (Fig. 3) having an enclosing casing in which the float chamber and a fuel valve casing are contained and which has an air inlet and a mixture outlet, means being provided to keep the fuel in the float chamber at the desired level. A valve rotatably mounted within the valve casing; the valve has a port adapted to register with an elongated slot communicating with the float chamber below the fuel level, and this slot and the port are adapted to communicate by means of a fuel passage. Through this connection the fuel flows from the float

chamber, being received by a cup-shaped member below the slot, the cup projecting above the fuel level existing in the float chamber, which arrangement prevents the carbureter from being flooded.

No. 1,000,518—To John Harris, Cleveland, O. Granted August 15, 1911; filed September 8, 1908.

**STORAGE BATTERY AND PROCESS OF TREATING SAME**—Specifies the constructive elements of an accumulator and chemical treatment therefor.

This patent protects the application of electrolytically active finely divided iron, or some other metallic material, intimately associated, with bismuth or bismuth amalgam. The process of treating the active metallic material consists in soaking the pockets containing it in a solution of bismuth trichloride in acetone.

Thomas A. Edison, Llewellyn Park, Orange, N. J., assignor to Edison Storage Battery Co., West Orange, N. J.; granted August 8, 1911; filed March 20, 1908.

**STARTING DEVICE**—Being a safety crank for starting internal combustion engines.

In Fig. 2 is shown the cranking mechanism consisting of a rotatable element or shaft, encircled by a coiled spring which in turn is encircled and connected to a sleeve, the spring having a ratchet disc connected

to one of its ends. The sleeve is encircled by a second spring to which is connected a rotatable member and this to a stationary one, the latter carrying a pawl which engages the ratchet disc above mentioned.

No. 1,001,303—To Samuel T. Reeves, Albany, Wis. Granted August 22, 1911; filed September 26, 1910.

**RESILIENT VEHICLE TIRE**—This is a tire to supplant pneumatics for automobile uses.

4. The patent covers a vehicle tire comprising a case tube formed with corrugations on its inner portion and split at its inner periphery. There are provided resilient walls having recesses open at their inner sides and forming a series of rounded cavities with the corrugations above mentioned. These cavities take up resilient balls which lend to the tire its elastic feature.

No. 1,000,165—to John B. Fischer, Chicago, Ill.; granted August 8, 1911; filed October 14, 1910.

**DRIVING MECHANISM**—Being of the friction wheel type.

3. The patents protect the combination, in a friction transmission, of a pair of opposed friction discs, a pair of friction wheels between the discs on a fixed common axis and means to bring the two wheels simultaneously into contact with opposite discs and on opposite sides of the disc axes.

No. 1,000,632—To Wilson Sprague, Portland, Me. Granted August 15, 1911; filed July 1, 1909.

**GRINDER**—Being a device for fitting valves in their places.

2. The valve grinder comprises a valve-engaging tool, a spiral shaft, an automatic clutch mounted on same, and actuator embracing the shaft, means for operating the actuator, including an adjustable crank, a momentum wheel on which the crank is mounted and transmission devices for operating the wheel mentioned and thereby the rest of the mechanism.

No. 1,000,553—To Peter Recconi, San Francisco, Cal. Granted August 15, 1911; filed February 23, 1911.

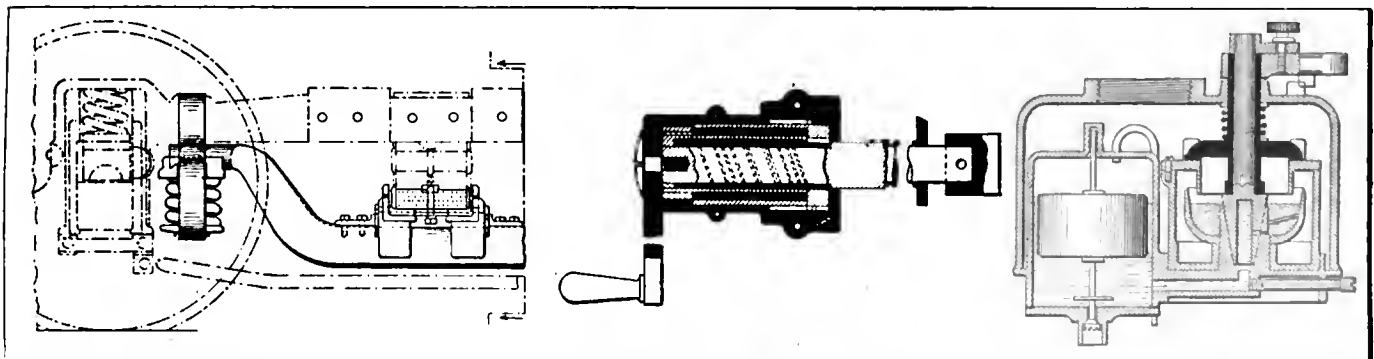

Fig. 1—W. S. Adams' car truck

Fig. 2—S. T. Reeves' starting crank

Fig. 3—J. Harris' non-floodable carbureter



## Seen in the Show Window

**T**HE Stryker muffler cut-out, which is shown in Fig. CM, is easily attached to the exhaust pipe. A round hole is cut into the exhaust lead, and the body of the cut-out, which is seen in the figure below the exhaust pipe, is brought to bear against the opening so that the exhaust gases may freely enter the cut-out space. Then the cap of the cut-out is fitted around the portion of the exhaust pipe directly above the hole cut in it, and cut-out cap and body are joined by means of cap screws, one of which is shown in the accompanying illustration. The cut-out pipe, under normal circumstances, is closed by a butterfly held in position through a spring, but when the lever attached to the butterfly valve is pulled toward the motor—to the right in the illustration—the metal plate forming the valve is brought into such a position as to permit the exhaust of the motor to pass through the cut-out, instead of flowing through the muffler. The Stryker cut-out is operated by means of a cable and snap, actuated through a bronze pedal from the driver's seat. The cut-out is the product of C. W. Stryker, of 314 E. Onondaga street, Syracuse, N. Y.

**A**T CN the Turner double-jet alcohol blowpipe is illustrated. The burner is mounted on a compound swivel so that the flame may be pointed in several divers directions. The tank is filled with alcohol which serves as the fuel, and instead of bellows being used, the air necessary to produce the needle-pointed flame is pumped into the flame by means of the hand pump arranged in the handle. The maker, Turner Brass Works, Sycamore, Ill., claims that a temperature of 3,000 degrees may be produced through the use of this torch.

**C**OMPRESSION is an indicator of some important engine conditions and to measure its amount the Edelmann compressometer, illustrated at CO, has been constructed. The principle of this meter is not unlike to that of the tire gauge. For testing the compression of a cylinder, the spark plug is removed therefrom and the compressometer, which comes in all standard spark plug threads, inserted in its place. Then with the ignition cut off the engine is once turned over by the flywheel, and the compression in pounds which shows on the dial is noted. The operation is repeated on all the cylinders, so that in case one of them is at fault the fact will become obvious. A red hand records maximum compression. E. Edelmann & Co., of 49 West Kinzie street, Chicago, Ill., manufacture this device.

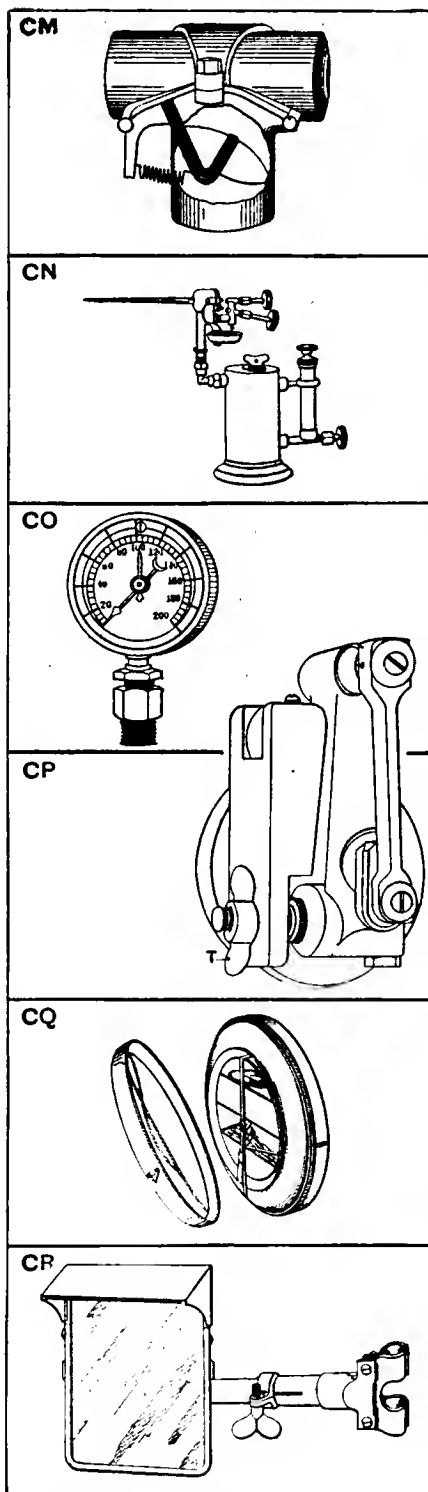

CM—Manner of Attaching Stryker Cut-out to Muffler  
 CN—Turner Double-Jet Alcohol Type of Blowpipe  
 CO—Edelmann Compressometer is Made in Spark Plug Threads  
 CP—Hart-Giant Tire Pump is Driven by the Motor  
 CQ—Argos Mirror Shows the Driver, the Cars Following Him  
 CR—Star Tire and Tool Case is of Large Capacity

**T**HAT it will pump a tire up to 90 pounds in a very short space of time with hardly any work on the part of the operator, is the claim made for the Hart Giant tire pump (CP). As the illustration shows, this pump consists of a cylinder in which a plunger is reciprocated by the action of a crankshaft rotated by a driving wheel. The pump is so mounted on the chassis frame by means of two brackets that the wheel of the pump comes in driving contact with the face of engine flywheel, if the thumb-screw T is given a turn. The 12-foot hose connection is connected up to the tire to be inflated, and the engine started and run at slow speed. A slight adjustment of the thumb-screw then brings pump wheel and flywheel into contact, whereby the plunger of the pump is reciprocated in its cylinder, compressing the air sucked therein, which is then led to the tire. The pump is made by Hart & Widder Co., 511 West Twenty-first street, New York.

**C**APACITY of the "Star" tire and tool case, made by the Merchant & Evans Company, of Philadelphia, Pa., is two shoes, two inner tubes in inflated state, in addition to from four to six folded tubes, and separated by a partition from a space for spare tools and like apparatus. The "Star," which is shown at CQ, is light of weight, its metal skeleton being covered with a waterproof fabric. The illustration shows the inner space divided for tubes above and tools below a partition, while the shoes are strapped to the body of the case in the manner shown. A hook and the bottom and two side latches, together with a lock on the top, keep the contents of the case protected from theft or loss.

**L**OOKING backward for the cars following one's trail is the chauffeur's work at times, but this work is as uncomfortable as it is fraught with risk. To enable the driver to see the rear of the road without turning his eye away from the portion before him, the Argos mirror, shown at CR, is attached to the windshield post by means of the positive-grip bracket seen in the figure made of brass. The shaft contains a ball-and-socket joint, permitting the mirror to be brought into and held in almost any desirable position. The glass is a high bevel plate and so fastened to the frame that it may be replaced without difficulty. One of the main features of this mirror is the ease with which the frame may be removed from its shaft, to which it is held by a thumb-screw. This mirror is made by the Motor Car Equipment Company, of 55 Warren street, New York.

# THE AUTOMOBILE



STARTING UP THE FIRST HEAVY GRADE OF THE LONG CLIMB ON BOSTON HILL WHERE MANY CONTESTING CARS CAME TO GRIEF

## Oakland Wins Buffalo Sweepstakes

### Flanders and Oakland Win Runabout Divisions

### Maxwell and Lion Win Touring Car Classifications



UFFALO, N. Y., Sept. 11—Oakland 24, a 40-horsepower runabout competing in Class 3A, proved the winner of the Laurens Enos trophy and the sweepstakes in the second annual reliability run of the Automobile Club of Buffalo, which was completed Saturday. The car was driven by Howard A. Bauer, contest driver of the manufacturing company, and had a clean score on the road and in the brake, clutch and motor tests. On final

technical examination, which was unusually thorough and searching, the car was given 8 demerits for five loose rivets and bolts, a loose fan pulley and a slight leak in a water connection.

Bauer drove the car with exceeding skill and care over a route of 855 miles, laid out over a series of hills that were unprecedented in reliability work, and the conditions were further complicated by intermittent showers and downpours that rendered some of the hills tractionless. There were three mountains included in the route, respectively and respectfully, Buffalo Hill, Boston Hill and Clarkesburg Mountain. Bauer nursed his car

over this trio and maintained his class schedule at every control. He of all the contesting drivers made a special effort toward uniform speed, varying only on the big hills, and making no effort to reach control ahead of time.

Flanders 4, driven by T. R. Bell, won the Class 1A division for runabouts with a total penalization of 48 points. Aside from its road penalties, which were the result of taking on water out of control, and lateness, this car was demerited 16 points on final examination. Four loose bolts, a broken fender and 5 points in the clutch test comprised the black marks. All were due to the bad roads, stiff hills and long schedule, and the showing of the car was most creditable.

Maxwell 2 won the 3A touring class with 51 demerits. These penalties were practically all accountable to troubles that had their origin in the carbureter and developed in greatest force immediately after a supply of high-proof gasoline had been taken on board at the noon control on the first day's run. This was different in quality than was appropriate for the carbureter adjustment, and resulted in considerable trouble for the car. In addition, the hills caused an extra drain on the water supply and gasoline consumption and renewals were necessary a number of times. In the final technical this Maxwell, which was driven



Maxwell "2," winner of the 3A class for touring cars and third in the general standing



Oakland 24, winner of Laurens Enos trophy in sweepstakes class



Oakland "24," the winner, being tested for brake efficiency by Chairman Edwards

by E. G. Gager, of the Pittsburgh branch of the United States Motor Company, was penalized 16 points. In the brake test the car slipped over the line 5 feet and Chairman Edwards, of the technical committee, discovered a broken lamp bracket, missing

ignition terminal, leaky gasoline connection and two loose rivets. The car showed fine speed on the roads and steadiness on the hills, but like every other contestant it was sharply tried by the first day's running.

Lion 6, winner of the 4A class, was heavily penalized through the breaking of a side member. This car was driven by Harry Blomstrom, from the Lion factory at Adrian, Mich., but was seriously handicapped throughout the run by a weak left rear spring. Blomstrom is an unusually skillful driver, but before the first day was over the car had laid the foundation for its ultimate demerits. The weak spring caused the car to pound on the rough roads, and this pounding loosened the drip pan under the engine. Blomstrom fixed it several times during the day and "took his points" for work. But the repairs could not be made in thorough fashion, and eventually, to make controls and stop the constant penalization, Blomstrom dropped the pan and went ahead. The second day was over comparatively dry roads and the car came through with few demerits, but on the third day water lay in pools on some sections of the route and, water splashing up past the place where the pan is held ordinarily, it short-circuited the magneto and led to considerable demeriting. On this day's run the Lion, at the head of the procession, picked up the pacemaker's flag at Levant, where a bridge had been washed out. The Pierce-Arrow pacemaking car, in going around the broken bridge, cut through the sod in a wet meadow and stalled for several hours. The Lion was obliged

TABLE SHOWING PERFORMANCE OF CONTESTING CARS IN BUFFALO CLUB'S RELIABILITY RUN

CLASS 1A RUNABOUTS—\$500 OR UNDER																			
No.	Car	Driver	First Day		Second Day		Third Day		Fourth Day		Road Tests			Tech. Ex.	Penalties Grand Total				
			Road	Tech.	Road	Tech.	Road	Tech.	Road	Tech.	Brake	Clutch	Motor			Total			
4	Flanders	T. R. Bell	0	3	0	0	0	0	0	23	6	32	0	5	0	5	11	48	
21	Ford	G. Morton Wolfe	0	0	0	0	0	0	5	0	43	48	5	0	5	10	15	73	
3	Flanders	B. W. Scott	0	3	0	0	0	0	0	Skidded and Withdrawn disabled		..	..	..	..	..	..	1,003	
9	Flanders	G. M. Herron	0	0	0	4	0	0	0	Skidded and Withdrawn disabled		..	..	..	..	..	..	..	1,004
CLASS 1A TOURING CARS—\$800 AND UNDER																			
14	Ford	{ N. Wilkinson } { L. J. Kinietz }	0	19	0	3	0	11	0	19	52	19	0	0	19	36	107		
CLASS 2A RUNABOUTS—\$801 TO \$1200																			
27	Paige-Detroit	J. E. McFadden	634	314	0	291	0	4		Withdrawn		..	..	..	..	..	..	2,243	
CLASS 3A RUNABOUTS—\$1201 TO \$1600																			
24	Oakland	Howard A. Bauer	0	0	0	0	0	0	0	0	0	0	0	0	0	0	8	8	
26	Warren-Detroit	J. D. Mohrhardt	0	6	0	1	0	0	0	0	7	41	0	0	41	31	79		
CLASS 3A TOURING CARS—\$1201 TO \$1600																			
2	Maxwell	E. G. Gager	6	12	0	14	0	0	0	3	35	5	0	0	5	11	51		
8	Everitt	J. W. Gardham	0	27	0	4	0	23	0	5	59	15	0	0	15	12	86		
10	Maxwell	Thomas Costello	0	46	0	58	0	2	0	0	106	5	0	0	5	6	117		
11	Schacht	E. W. & C. H. Werick	Hit wagon, damaging axle								Withdrawn		..	..	..	..	..	1,000	
1	Maxwell	C. F. Monroe	Disabled on account of collision								Withdrawn		..	..	..	..	..	1,000	
CLASS 4A TOURING CARS—\$1601 TO \$2000																			
6	Lion	H. L. Blomstrom	0	11	0	8	0	20	47	27	113	0	0	5	5	508	626		
CLASS 5A TOURING CARS—\$2001 TO \$3000																			
12	Ohio	E. A. Blaney	0	96	0	3	0	14		Withdrawn		..	..	..	..	..	..	1,113	

to go along at high speed and thus probably aggravated its troubles. The final day nearly brought the car to grief in climbing the two mountains that lay this side of noon control. It is said that a horse has not climbed these hills in forty years, although there is some little travel on the down grade. It took all the Lion's power to get to the top and a big spurt of speed was necessary to make control. There it was discovered that a side-member was cracked, and in that condition the rest of the run was made. The car checked in 47 minutes late and its total penalization was 626, all of which was traceable to a weak spring.

Everitt 8, driven by Joseph Gardham, made a spirited fight for the class trophy in 3A division. Like all the rest of the contestants, the Everitt was crippled by the first day's run. The jolting caused a leaky pump and the engine ran hot. This aggravated carbureter troubles and an accident bent a spindle, causing further penalties in the final brake tests. The car had rather less trouble on the hills than its competitors, but the first day made a clean score impossible for any of the cars and weighed heavily upon the Everitt.

Maxwell 10, driven by Thomas Costello, suffered carbureter trouble the first day after getting the 70-proof gasoline, and was heavily penalized for work done in clearing and adjusting the carbureter. The car showed up well in the finals and but for the incident of the carbureter would have been near the front.

Ford 14, a factory car equipped with a touring body, performed very creditably. It was penalized 107 points all told, and certainly would have been entitled to the class trophy in the 1A touring division if it had carried its full load on all four days.

Through some oversight, however, the car was entered with the runabouts and on the first two days did not carry its quota of passengers required by the rules governing touring cars.

Ford 21, in the runabout class, finished in good style, driven by a member of the Automobile Club of Buffalo, M. W. Wolfe. Its road score was clean for the first two days, but the terrific strain of those periods became manifest in the latter portion of the run and Ford 21 had difficulty in getting home. Chairman Edwards found fifteen loose rivets and brake and motor troubles.

The Warren Detroit 26 was the only other car to finish, and it was severely penalized on technical examination. A spring horn and spring clip were broken and the emergency brake failed to hold by 39 feet. The car made an astonishing showing on the road during the last two days, coming through with a perfect score.

Accidents eliminated most of the other starters. The toughest luck of the tour was experienced by Maxwell 1, driven by Charles F. Munroe, local representative of the United States Motor Company. Last year Mr. Munroe won the Enos trophy in the

WHYS AND WHEREFORES OF THE PENALTIES

2	MAXWELL	Lamp bracket broken.....	5	
		Broken magneto terminal.....	2	
		Leaky gas connection.....	1	
		Lamp bracket loose.....	2	
		1 rivet loose.....	1	
		Foot brake.....	5	16
4	FLANDERS	2 lamp brackets loose.....	4	
		2 mud apron bolts loose.....	2	
		Broken fender.....	5	
		Clutch.....	5	16
6	LION	Broken frame member.....	500	
		Lost mud apron.....	8	
		Cylinder misaing.....	5	513
8	EVERITT	Lamp bracket loose.....	2	
		Broken fender.....	5	
		2 pan bolts lost.....	4	
		1 pan bolt loose.....	1	
		Emergency brake.....	15	27
10	MAXWELL	Leaky radiator.....	1	
		Leaky gasoline line.....	1	
		2 loose rivets in cross member.....	2	
		Loose shock absorber.....	2	
		Foot brake.....	5	11
14	FORD	Loose muffler.....	2	
		8 nuts loose.....	8	
		Loose nut on strut rod.....	1	
		Broken strut rod.....	25	
		Emergency brake.....	19	55
21	FORD	14 rivets loose in motor support.....	14	
		1 rivet loose on cross member.....	1	
		Emergency brake.....	5	
		Motor missing.....	5	25
24	OAKLAND	Leaky water connection.....	1	
		2 mud apron bolts loose.....	2	
		2 mud apron rivets loose.....	2	
		1 rivet in cross member loose.....	1	
		Loose fan pulley.....	2	8
26	WARREN-DETROIT	Loose spring horn.....	15	
		Spring clip broken.....	15	
		Muffler wire broken.....	1	
		Foot brake.....	2	
		Emergency brake.....	39	72



Looking north from the summit of a stiff hill not far from Cattaraugus



Lion 6, class winner, with the pacemaker's flag on third day



Flanders 4, winner in its class and second in the sweepstakes.



Maxwell 10, swinging through one of the level spaces included in the route of the tour's second day, showing character of the roads traversed

tour with a Maxwell car, and this year with one of the new Specials he announced that he was going after it again. The car led the procession to within 50 miles of noon control, when it collided with an Abbott-Detroit racing machine that was accompanying the caravan as a non-contestant. The rear axles of both cars were kinked and the Maxwell was badly disabled. Mr. Munroe was making temporary repairs to get as far as the noon control when the Schacht 11, contesting in the same class, came careering along, striking a hay wagon and rebounding against the crippled Maxwell. When the mud had settled it was found that the axle of the Maxwell was sheered, while the Schacht was put permanently out of commission with a similar injury.

Flanders 3 and 9 succumbed on the fourth day's run. The latter had a clean score the first and third days, and was penalized only 4 points on the second day for a spark-plug adjustment. During the same time its teammate received 3 demerits the first day for taking on water, while on the second and third days its score was clean. But on that fierce fourth day both the little cabs withdrew. It was the Clarksburg mountain that put them out of the running, both skidding from the road and smashing into trees in such position that they could not be repaired or extricated in time to continue. It was a curious fact that the winning Flanders was much more heavily penalized on the road than the pair that withdrew, although a large part of these points came as a result of the last day's run.

Ohio 12 had a stormy journey. It was the biggest and most costly car in the run and consequently had to labor harder on



Warren-Detroit 26, which made a gallant showing and finished

the hills, and in addition was obliged to make a 20-mile-an-hour schedule. The first day brought it 96 demerits for work on clutch, carburetor and in taking on supplies. The route was unfair to such a big car despite the fact that the Pierce-Arrow and Thomas six-cylinder cars were able to negotiate it. It did better the next day, but began to go back rapidly during the tremendously long run of the third day. Boston Hill got the Ohio's scalp after the car had skidded across the road and lay helpless near the foot of the mountain.

Paige-Detroit 27, a rather old model of this make, developed the only downright mechanical defect during the tour. The Paige was equipped with differential pinions of unequal hardness. This resulted in disablement on the first day which rolled up an imposing number of demerits against the car. Nevertheless, McFadden worked industriously on the car at night and was ready to start the next morning, not having rested for a minute. The car was given nearly 1,000 points, and the second day produced 291 more. The third day was better and the entrant had hopes of finishing, when Clarksburg Mountain intervened and the Paige came back by freight.

It was a fierce contest over roads that would have furnished a tremendous test of stock automobiles under the best of weather conditions. But such conditions did not obtain. A deluge swept over the northern half of New York State on Tuesday night, and when the cars were called to the line at 6:30 Wednesday morning it was freely predicted that none would make night control within three hours of schedule. The course led to Buffalo Hill by a winding way. There is a sharp turn approaching the heavy grade and the cars had to proceed rather leisurely in the early part of the ascent. The hill is of flint, streaked with seams of blue clay, and in dry weather is simply a very steep, smooth mountain road over the hardest kind of bed. But on Wednesday it was different. The rain had dissolved considerable clay above the road and had washed it down upon the flint, so that when the cars approached the slippery bed had been covered to the depth of half an inch with this perfect lubricating substance. Chains were useless and all the cars fought it out on a basis of main strength. That they arrived at the top is a speaking testimony of the power of the modern stock automobile.

Beyond the hill were more hills, some of them quite as steep as Buffalo and some much rougher, but none like it. It was Buffalo that made clean scores impossible for such automobiles as contested, or, in fact, any others.

The first day's run was 207 miles, and four more were added by a detour. They were such miles as only Dai H. Lewis could select when he was in a selecting humor, and, to make



the situation worse, they were soggy and slippery and badly cut up in spots.

The second day proved to be the easiest of the tour, which is not saying much. The route was only 200 miles long, which required the Class 1A cars to travel 12 1-2 hours.

The third day was through some of the most magnificent road scenery in the world. From Buffalo to Bradford, Pa., the way was somewhat similar to that covered on the other days, but from Bradford to Warren, Pa., the landscapes deserve the attention of some master painter. The Automobile Clubs of Bradford and Warren take a just pride in the roads and see that they are maintained, but even with just ordinary roads the trip would be gorgeous.

But that is about all. From Warren back to Buffalo it was a grind and the day wound up with a mileage of 222. This was occasioned by two bridges being washed out. The first of these necessitated a change in route through the Iroquois reservation where the roads were trying, and the second brought the official pacemaker to grief. The Pierce-Arrow car that carried the referee stuck in the mud near Levant and the stiff wind that sprung up later in the day caused the confetti to be blown to the right side of a long stretch of good pike, thus leading the Lion, which had taken up the pacemaking, to make a wrong turn. All the cars followed, and as a result a big addition to the day's run was made.

The last day was the terror of the four. Weakened and racked by the strenuousness of the foregoing days, four cars bowed to the inevitable and retired during the morning.

The reason lay in the fact that Boston Hill and Clarkesburg Mountain are two of the stiffest ascents ever presented to automobiles for negotiation. Boston Hill came first on the itinerary. In the middle of summer, when no rain has fallen for a couple of weeks, Boston Hill might be used as a sort of ultimate test for hill climbing by automobile manufacturers. Few would even try to climb Clarkesburg. Each is long and 30 per cent. grades are not uncommon. In fact, several of the veteran drivers declared that the maximum grades were steeper. Over each of these hills is an arch of trees and the roadway, which is sometimes used for horse travel on the down grade only, is composed of blue clay. The tree arches serve to keep off the sun and keep in the moisture, and when the head of the procession reached the beginning of the Boston Hill there was no more traction to be had than there would be on the side of a house. Some tried it on low gear and others backed up the grade. Four cars failed to get up at all.

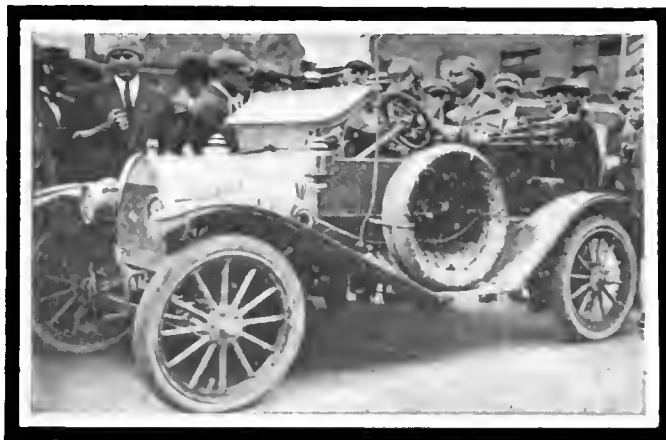

Ford "21," which looked like a winner in Class 1A until the final day of the tour

The clutch test was passed in good shape by all the cars, a few penalties of 5 points each being imposed.

Then came the final technical inspection by Chairman Edwards. It was of the fine-tooth comb variety and went clear to the vitals of all the cars.

It was a magnificent tribute to the sturdiness of stock automobiles of modern manufacture that as many as nine cars finished the run and that only six fell by the wayside.

SOME OF THE DETAILS OF THE CONTESTANTS

Class 1A, Runabouts					
No.	Car.	Motor.	Tires.	Carbureter	Ignition
3	Flanders	3 3/4 by 3 3/4	M. and W.	Flanders	Splitdorf
4	Flanders	3 3/4 by 3 3/4	M. and W.	Flanders	Splitdorf
9	Flanders	3 3/4 by 3 3/4	M. and W.	Flanders	Splitdorf
21	Ford	3 3/4 by 4	Diamond	King	Ford
Class 1A, Touring					
14	Ford	3 3/4 by 4	Diamond	King	Ford
Class 2A, Runabouts					
27	Paige-Detroit	3 3/4 by 4	Diamond	Mayer	Bosch
Class 3A, Runabouts					
24	Oakland	4 1/2 by 5	Goodyear	Schebler	Remy
26	Warren Detroit	4 by 4 1/2	Diamond	McCord	Voltamagneto
Class 3A, Touring					
1	Maxwell	4 1/2 by 5 1/4	Ajax	Stromberg	Splitdorf
2	Maxwell	4 1/2 by 5 1/4	Ajax	Stromberg	Splitdorf
10	Maxwell	4 1/2 by 5 1/4	Ajax	Stromberg	Splitdorf
8	Everitt	4 by 4 1/2	Diamond	Metzger	Bosch
11	Schacht	4 5-16 by 5	Diamond	Schebler	Bosch
Class 4A, Touring					
6	Lion	4 1/2 by 5	Firestone	Stromberg	Splitdorf
Class 5A, Touring					
12	Ohio	4 1/2 by 4 3/4	Goodrich	Schebler	Splitdorf



Maxwell Trio and Ford touring car in close order during the early part of the first day's running after passing East Aurora

# National Stars at Port Jefferson



National 17, which proved the winner of two events on Saturday, making the severe turn at the elbow; Donald Herr driving

**R**IVALRY, friendly but intense, marked the second annual hill-climbing contest of the Automobile Club of Port Jefferson. The hill, a measured 2000-foot course, with a 400-foot flying start, was lined with the residents of Port Jefferson and the vicinity, who had come to view the contests in spite of the weather conditions—rain threatening all the afternoon. Additional interest was given the well-contested matches by an elbow located at about the center of the course, and of such an angle that the approaching cars were concealed from those who clustered about the finish line until they had rounded the bend and were on the final stretch. The manipulation of the curve proved to be a great factor in determining the time of the climb, for in many instances where the time of two rival cars was close it was noticed that the winner proved almost invariably to be the one who had made the better turn.

The gradation of the hill ranges from 6 to 16 per cent. At the start there is a sharp rise for about 800 feet; the slope then becomes easier until the bend is reached, at which point it attains the maximum. There were very few instances in which the contestants dropped to second speed, and when they did they were in all cases badly defeated. The changes of gear were made just above the elbow by the smaller cars.

No accidents of any consequence marred the afternoon's sport, the nearest approach to a disaster being when the National car No. 17 went through a hedge fence after having passed the finish line and while still traveling at a rapid rate. The car was checked just before reaching the steps of the veranda of a private residence and was backed out without any damage hav-

ing been done except that to the shrubbery. The course was kept clear during the entire race by means of specially appointed police.

The events for small cars opened the races, the first car coming up the hill being one of the Fords. After this the different events were intermingled one with another, thus furnishing a variety. The first two events for stock cars were won by Ford cars, the second places in both these events likewise going to the Fords, four of which were entered by Messrs. Bishop, McCormick & Bishop. The Krit in the first event was the only car during the race whose official time stood over one minute, although there were several cars which went over this time in one of the two attempts which were allowed. The Krit car did not take a second trial in this event.

The National cars distinguished themselves by winning all the large events of the day, including the free-for-all for the beautiful Ardenrcraig trophy, besides the races in their class for sell-

## PORT JEFFERSON HILL CLIMB SUMMARIES

Gasoline Stock Cars, \$800 or Under			
No.	Car.	Driver	Time
13	Ford	Bishop	44.88
12	Ford	Bishop	55.27
42	Krit	Rud. Wehr	1:37.87
Gasoline Stock Cars, \$801 to \$1,200			
40	Ford	Moe Lawson	43.06
10	Ford	McCormick	46.61
19	Paige-Detroit	J. Craig	48.71
Gasoline Stock Cars, \$1,201 to \$1,600			
31	Lion	F. S. Appar	29.22
24	Correja	Joe Taylor	33.95
Gasoline Stock Cars, \$1,601 to \$2,000			
2	Corbin	H. B. Tucker	32.90
8	Cole	Walter Blair	43.55
36	Vetlie	A. M. Campbell	46.25
21	Colby	J. Craig	47.95
Gasoline Stock Cars, \$2,001 to \$3,000			
14	National	Donald Herr	*24.45
22	Mercer	Hughie Hughes	25.40
37	Mercer	Clifford Griswold	28.09
Free-for-All, Ardenrcraig Trophy			
17	National	Donald Herr	21.31
15	Knox	J. J. Coffey	21.57
1	Pope-Hartford Hummer	Louis A. Disbrow	23.87
16	Knox	Fred Belcher	24.04
27	Fiat "90"	R. W. Stuard	24.90
22	Mercer	Hughie Hughes	27.09
6	Mercedes-Simplex	D. M. Bellman	28.27
Cars of 161 to 230 Cubic Inches Piston Disp.			
31	Lion	W. Apper	27.57
60	Krit	W. Jones	36.20
51	Jackson	S. C. Hutchinson	28.26
28	Courier	Wm. Davis	42.24



The Mercer car driven by Hughie Hughes, winning the event for its class in piston displacement

# Record for the Hill Still Stands



The Ford T, which finished first in its class for selling price

The Lion 40, driven by Apgar, which finished first in two events

ing price and piston displacement. The amateur event, won by the National 14, driven by W. J. Fallon, was protested by E. B. Hawkins, a post-entry to this race. The protest was officially made in writing at the termination of the race, on the ground that the National car was not owned by the entrant for the required thirty days before the race. This matter will be decided later by the A. A. A., under whose auspices and rules the race was held.

The third event consisted of but two entries, a Lion car which won the race and a Correja which lost by about four seconds. Both these cars climbed the hill in far less time than that in which the climb was made last year by the winner of the corresponding event. In fact in every case except the free-for-all and that of stock cars selling from \$1,601 to \$2,000 last year's time was considerably bettered.

The fourth event was won by the Corbin, which had a margin of about ten seconds on its nearest rival, the Cole driven by Walter Blair. The Corbin was driven by the owner, H. B. Tucker. In this event the Velie car very nearly stalled its motor on the first attempt at the bend, taking over a minute and fifteen

seconds to climb the hill. On the second attempt, however, the Velie made the climb in 46.25 seconds, taking third place in the race.

Very fine time was made in the fifth event, the National No. 14, driven by Herr, proving to be the winner by less than one second over the Mercer driven by Hughes. The Mercer did not take the bend as quickly as the National, losing considerable time on the skid. The National car held closer to the crest of the road, making a much prettier turn and saving time.

The stock car events on the card were most carefully observed by the automobile owners and prospective owners in the assembled crowd and while the representatives of these classes did not make as much noise as the speed creations that competed in the free-for-alls, their performances attracted considerable discriminating attention.

The free-for-all excited the liveliest interest. The assembled crowd wanted thrills and they got them in this race. The first car, a Mercedes-Simplex with chain-drive, thundered up the hill, seeming to gain speed every instant. Just as it reached the finish line it swerved into the gutter, breaking the timing wire and sending a shower of pebbles about the judges' stand. No damage was done the car, however, and the excitement soon quieted down while the necessary repairs were being made. It was in this race that the best time was made. The National car climbed the hill in 21.31 seconds, which was the fastest time of the day. This did not upset the record made last year by Ralph de Palma in a Fiat car as his time was 20.48 seconds.

When the other drivers learned the time made by Donald Herr in the National a number of them resolved to take advantage of the second opportunity to which they were entitled under the rules. The Mercedes-Simplex was among those which tried the

## PORT JEFFERSON HILL CLIMB SUMMARIES

### Cars of 231 to 300 Cubic Inches Piston Disp.

22	Mercer	H. Hughes	25.55
34	Corbin	Al. Maisonville	27.32
9	Cole	Ernest Heyrel	29.12
5	Staver-Chicago	Fred. Wright	32.64
24	Correja	Joe Taylor	32.76
19	Paige-Detroit	J. Craig	47.07

### Cars of 301 to 450 Cubic Inches Piston Disp.

14	National	Donald Herr	23.19
1	Pope-Hartford Hummer	Fred Belcher	24.79
16	Knox	L. A. Disbrow	24.33
31	Lion	W. Apgar	33.14

### Cars of 451 to 600 Cubic Inches Piston Disp.

17	National	Donald Herr	21.37
15	Knox	J. J. Coffey	21.90
16	Knox	Fred Belcher	24.52
6	Mercedes-Simplex	D. M. Beilman	28.22
5	Staver-Chicago	Clifford Gresivold	35.42

### For Amateurs, Cars Selling Up to \$1,200

2	Corbin	H. B. Dueker	34.56
40	Ford	Moe Lawson	41.80

### For Amateurs, Cars Selling for \$2,001 or Over

14	National	W. J. Fallon	*25.30
52	Knox	E. B. Hawkins	34.23
56	Speedwell	R. C. Vandeventer	39.97
23	Acme	Wm. R. Brass	55.55

### For Amateurs, Port Jefferson Owners

26	Buick	Charles Bishop	33.43
5	Staver-Chicago	Clifford Gresivold	35.42
53	Pierce-Arrow	Donald Alvord	35.54
28	Cononir	Wm. Davis	41.52
4	Buick	R. Schmeltz	51.02

### Special Event, Match Race

3	Metz	Wm. Buehanan	38.50
13	Ford	C. M. Bishop	46.63

\*Protested.



The Corbin car driven by Maisonville, which finished second in its class, approaching the starting line



National car which will win three events if protest is not allowed



Belcher receiving starting instructions while seated in his Knox car

second climb, and it again distinguished itself by scraping the gutter and carrying away the finishing wire. After having torn down the wire the car continued gaily on its way, concluding its performance by very nearly ramming a touring car filled with innocent spectators. The National's time was not touched and stood as the day's record, and with it went the possession of the Ardenraig Trophy.

The other races which were graded by piston displacement were won by the Lion car, driven by F. S. Apgar; Mercer, driven by Hughie Hughes, and National by Donald Herr (two races).

The amateur events, open only to residents of Port Jefferson and vicinity, excited great interest, and the attempts of the rival drivers to better each other's time were cheered by their neighbors who were gathered on the hillside. It was in the amateur race for cars selling over \$2,001 that the protest was entered by E. B. Hawkins, who is postmaster of Huntington, a near-by town, against the National car driven by W. J. Fallon, the promoter of the race. Mr. Hawkins was second in his Knox.

A special event between a Ford and Metz 22 went to the latter rather handily.

The officials were as follows: Racing Committee, W. J. Fallon, A. O. Smith, G. E. Darling; Manager Parking Space, Paul B. Franklin; A. A. A. Representative, Frank G. Webb; Referee, A. R. Pardington; Judges, D. M. Gerard, Willard Bayles, Dayton Hedgess, Luther Chambers, C. B. Zabriskie, Carl S. Buer; Clerks of Course, W. J. Fallon, Tom Fallon, Arthur Burns; Starter, E. C. McShane; Assistant Starters, George Robertson, Jack E. Connell; Chief Timers, William Poertner, A. G. Inderreiden; Announcers, H. J. Fenn, H. J. Willetts, Will Robins, Jacob S. Dreyer; Technical Committee, A. F. Comacho (Chairman), Ben T. West, Henry Souther, A. F. Sammiss, J. H. Downer, F. C. Griswold, A. N. Randall, Thos. Fanning; Scorers, Steve Fallon, Leslie Davis, Chester Darling, Archie Graham, William S. Lawson; Entry Committee, William J. Fallon, George Darling. The timing was done by an electric trip wire and telephone made by Warner Instrument Company.

The race was a success in every way and will no doubt be repeated next year by the Automobile Club of Port Jefferson.

### Speed Rates of Port Jefferson Winners

Following is a table of speed rates made by the winning cars in each of the fourteen events of the Port Jefferson hill climb:

Event.	Car.	Time.	M. P. H.
1	Ford	44.83	31.1
2	Ford	43.06	31.7
3	Lion	29.22	46.7
4	Corbin	32.90	41.4
5	National	24.45	55.8
8	National	21.31	64.0
9	Lion	27.57	49.6
10	Mercer	25.55	53.3
11	National	23.19	58.8
12	National	21.37	63.9
14	Corbin	34.56	39.5
15	National	25.30	53.9
16	Buick	33.43	40.7
17	Metz	39.38	34.7

## Dealers' Week in Detroit

*Studebaker and Ford Agents in Conference*

DETROIT, MICH., Sept. 11—Dealers have been pouring into Detroit in a steady stream the past week, and the migration continues without any indication of waning interest or enthusiasm on the part of those who are doing the entertaining. This morning a delegation of nearly 200 E-M-F dealers from Texas and Oklahoma arrived in one of the Studebaker Corporation's specials for a two days' visit, and they will be followed, later in the week, by the Kansas City delegation.

More than 400 dealers were entertained by the Studebaker Corporation and the Ford Motor Co., alone, last week. The Ford visitors included dealers from Wisconsin and Iowa. The Badger State contingent was accompanied by six Milwaukee newspaper men. The visitors were entertained with a luncheon at the Log Cabin Inn, a spin to Grosse Pointe and a dinner at the Hotel Tuller in the evening.

Thus it has been one continual round of handshaking, explaining and entertaining, with luncheons every day and banquets every night. In addition to establishing a stronger personal relation between manufacturer and dealer, these visits have enabled the dealers to study the details of construction at first hand, and this knowledge, naturally, is bound to be a valuable asset in the selling of cars.

A party of 300 leading business men of the Upper Peninsula were the guests of the Detroit Board of Commerce, Wednesday and Thursday of last week, and were taken through the Packard and Chalmers plants, Thursday morning. The visitors were received by Lee Counselman, vice-president and general manager of the company, and they were escorted through the plant by officers and heads of departments. Each was presented with a souvenir in the form of a Chalmers watch fob.

The Cartecar Company is now occupying its handsome new building at Woodward and Hendrie avenues, which is a marked improvement over the company's old show rooms.

Harry Paxton and A. A. Crumley, both of whom are well known in local motor car circles, will go to Philadelphia as eastern distributors for the Warren Motor Car Co. They will do business under the style of the Paxton-Crumley Auto Co.

All doubt as to the Flanders 20, which recently won the St. Louis-Kansas City reliability run, being a stock car has been removed. George E. Lane, local representative of the American Automobile Association, made a thorough inspection of the car last week after personally breaking the seals of the freight car in which the machine had been shipped back to Detroit, and wired Chairman Butler, of the contest board, that the car was stock in every particular.

The McCord Manufacturing Co., whose business has grown to enormous proportions since the concern's removal to Detroit, has just let contracts for a one-story brick addition to its plant on the East Grand Boulevard.



Cars assembled near the starting line in Port Jefferson awaiting their turns to participate in the events

## No Records at Old Orchard

*Course Was Found to Be Short*

OLD ORCHARD, ME., Sept. 6—The feature of the three-day beach meet here, which closed this afternoon, was the bitter struggle for the honors in the 100-mile race between John Rutherford, in a National car, and Louis Disbrow, driving a Pope-Hartford. The former won the long grind in the fast time of 98:00 4-5, finishing 1 minute 17 1-5 seconds ahead of his rival. Had it not been necessary for Disbrow to stop during his fifty-first mile to replace a lost tire—an operation that cost him fully three minutes and a half—it is quite probable that the finish would have been of the blanket variety.

The National took the lead at the start, but in the tenth mile the Pope-Hartford swung into the lead, which it held until Disbrow came to grief in the fifty-first mile. Rutherford led from that point to the finish, although the Pope-Hartford cut a trifle off its opponent's advantage with each circuit. The time of the two contenders for each 25 miles was as follows:

Miles .....	25	50	75	100
National .....	22:36	45:12	65:35	98:00 4-5
Pope-Hartford.....	22:15	44:28	69:38	99:18

The time would have been much faster had it not been for the incoming tide, which drove the contestants farther up on the beach, where the going was much too soft for the fast work which had characterized the earlier stages of the race.

Besides the National and the Pope-Hartford there were four other starters—Pope-Hartford, driven by C. L. Bowler; Inter-State, Harry Endicott; Buick, C. G. Jessup, and Jackson, Harry Cobe. Bowler finished third in 109:37, and Endicott fourth in 110:37, the former getting the show position despite the fact that he covered the last few miles of the race on three tires. Jessup and Cobe failed to finish.

The 25-mile free-for-all was a sop to Disbrow, however, for he nosed out Rutherford by the small margin of one second, covering the distance in 15:25. The Jessup Buick finished third, followed by Bowler's Pope-Hartford and Endicott's Inter-State.

A match race at 10 miles between an Inter-State, driven by Neilson, and a Cole 30, piloted by Habich, resulted in a win for the former in 7:56 1-5, his opponent finishing one-fifth of a second behind.

In a mile exhibition against time a Stanley Steamer, driven by L. F. N. Baldwin, negotiated the distance in 39 seconds, lowering his best previous effort by an even second. A 5-mile trial by Disbrow in his Pope-Hartford was clocked in 3:58. The summaries are in the following column.

Regarding the remarkable times made by the contesting cars, and the early claim for records which were made as a result thereof, it has developed that such claims will not stand, owing to the wrong placing of the marker designating the easterly limit of the supposed 2 1-2-mile course. The official to whom was assigned the task of placing the marker fell shy of the required

distance by a considerable number of feet. Although the difference was slight it was sufficient to nullify the possibility of official recognition of any records that may have been made.

Arrangements have been made for races to be held at the beach in July of next year. Three thousand dollars in prizes has already been posted and there will be a longer and a better list of entries even than there was this year.

## Automobile a Feature of Country Fairs

MORRISON, ILL., Sept. 9—That the country fairs are becoming more or less automobile shows for the farmers was shown this week at the annual Morrison Fair, the big western Illinois State fair.

In the three days there were counted from 750 to 800 visiting cars each day and the booths and tents of the various exhibitors were crowded each day with farmers and others anxious to see what the new ideas would be for the coming season.

Each exhibitor had from one to three cars on the grounds either in the open or in tents. The Buick showed three new cars, including a truck which was demonstrated to the farmers; Regal three cars, including the new underslung; Overland, Oakland, Cadillac, Reo and Ford, one car each.

One of the most interesting features of the show was the loading of the Buick regular 1,800 lb. delivery truck with 32 men, places being provided for by means of planks, and making two laps of the half-mile track in excellent time. Sales reported showed that each exhibitor was well pleased with the show and that a great many future sales would undoubtedly result from the exhibition.

### Last Day's Summaries at Old Orchard

25-Mile Free-for-All		Time.
1. Pope-Hartford	Driver Louis Disbrow	15:25
2. National	John Rutherford	15:26
3. Buick	G. C. Jessup	15:26 1/2
4. Pope-Hartford	C. L. Bowler	15:36 1/2
5. Inter-State	Harry Endicott	15:39 1/2
Match Race—10 Miles		
1. Inter-State	V. A. Neilson	7:56 1/2
2. Cole "30"	H. J. Habich	7:56 1/2
Stanley Steamer	L. F. N. Baldwin	:40
Pope-Hartford X	Louis Disbrow	3:58
50-Mile Free-for-All		
1. National	John M. Rutherford	30:06 1/2
2. Pope-Hartford	Louis Disbrow	30:13 1/2
3. Pope-Hartford	C. L. Bowler	30:40 1/2
4. Inter-State	Harry Endicott	.....
5. Jackson Flyer	Harry Cobe	.....
100-Mile Free-for-All		
1. National	John Rutherford	98:00 4-5
2. Pope-Hartford	Louis Disbrow	99:18
3. Pope-Hartford	C. L. Bowler	109:37
4. Inter-State	Harry Endicott	110:37
5. Buick	G. C. Jessup	.....
6. Jackson Flyer	Harry Cobe	.....





Fiat, No. 9, Hearne driver, which captured first place in the race for the Cincinnati trophy



Eddie Hearne, who piloted the winning car in the big race

## Cole and Fiat Feature Fern Bank

CINCINNATI, O., Sept. 10—Cincinnati's first attempt at road races was carried through very successfully Saturday as a climax to the week's celebration of the opening of the Fern Bank dam across the Ohio River. The races

in starting and after sharp work by both driver and mechanic the car had covered 20 feet in the first fifteen minutes and was withdrawn. It was found when the car was examined later that a pin or key in the transmission had caught.

RESULTS OF THE RACE FOR THE CINCINNATI TROPHY

No.	Car.	Driver.	Bore.	Stroke.	Lap No.	1	2	3	4	5	6	7	8
9	FIAT	Hearne	5 1/2	5	Elapsed time	8:33	17:02	25:28	33:46	42:10	50:29	59:01	67:11
					Lap time		8:29	8:26	8:18	8:24	8:19	8:32	8:10
3	COLE	Jenkins	4 1/2	4 1/2	Elapsed time	10:56	19:47	28:28	36:56	45:26	53:48	62:09	70:30
					Lap time		8:51	8:41	8:28	8:30	8:22	8:21	8:21
10	WESTCOTT	Knight	4 1/8	5 1/4	Elapsed time	9:01	17:56	26:55	36:00	45:01	53:57	62:52	71:51
					Lap time		8:55	8:59	9:05	9:01	8:56	8:55	8:59
4	OHIO	Matthews	4 1/8 1/2	4 3/4	Elapsed time	9:38	18:56	28:34	37:56	47:17	56:21	65:46	80:41
					Lap time		9:18	9:38	9:22	9:21	9:04	9:25	14:55
6	CINO	Gilchrist	4 3/8	5	Elapsed time	10:34	19:00	28:48	38:26	47:57	57:12	66:29	75:59
					Lap time		9:26	9:48	9:38	9:31	9:15	9:17	9:30
5	OHIO	Thatcher	4 1/8 1/2	4 3/4	Elapsed time	8:55	18:08	27:53	37:12	46:22	55:39	64:56	74:12
					Lap time		9:13	9:45	9:19	9:10	9:17	9:17	9:16
2	SCHACHT	Jeffkins	4 3/8	5	Elapsed time	11:44	20:43	30:32	40:06	49:27	58:50	68:11	77:28
					Lap time		8:59	9:49	9:34	9:21	9:23	9:21	9:17
7	CINO	Burke	4 3/8	5	Elapsed time	8:52	17:44	26:46	35:03	Withdrawn, broken con-			
					Lap time		8:52	9:02	8:17				
8	CINO	Raimey	4 3/8	5	Elapsed time	Withdrawn, turned over							
					Lap time								
11	STUTZ	Anderson	4 3/4	5 1/2	Elapsed time	Withdrawn.							
					Lap time								
20	COLBY	Pearce	4 1/4	5 1/4	Elapsed time	Withdrawn, broken wheel.							
					Lap time								

were run over the Silverton-Blue Ash-Montgomery course near the town of Rossmoyne, about 15 miles out of the city. The course was a triangular one, with one very sharp turn. The length was 7.9 miles and the road none too well prepared for fast work.

Of the two races, which were run simultaneously, the big one was for a distance of 200 miles and the other was 150 miles. Eddie Hearne in the Fiat carried off the honors in the 200-mile event, winning the Cincinnati trophy at an average speed of 57.5 miles per hour. Jenkins in the Cole took second in this race and first in the 150-mile event, to which the Fiat was not eligible. Second place in the smaller race, for the Hamilton County trophy, was made by Thatcher in the Ohio.

All the cars but the Fiat, Stutz and Westcott, competed in both races, the relative position at the end of the nineteenth lap determining the standing in the 150-mile event.

Of the twelve entries for the two races all appeared at the starting point, but Mortimer Roberts in the Abbott-Detroit which held No. 1 showed up at the very last minute. The seating arrangement of the Abbott had been changed so that the mechanic was immediately behind the driver and Technical Executive F. E. Edwards refused to allow the experiment.

Things commenced to happen before all the cars had gotten away. The No. 11 Stutz, driven by Gil Anderson, had trouble

Two other cars met with disaster in the first lap. The first occurred when Raimey in the Cino No. 8 threw a tire and turned over near Blue Ash. Raimey suffered a slightly sprained wrist and the car was out of the race. Then the No. 20 Colby



Westcott, No. 10, Harry Knight driver, which finished third in the 200-mile race



Jenkins, who drove the Cole to a win in the small car race and second in the big event

Cole 30, driven by Jenkins, which after winning 150-mile race, went on and captured second in the 200-mile

went out with a broken wheel, Pearce, the driver, getting slightly scratched up in the wreck.

In the fifth lap the No. 7 Cino, with Andy Burke at the wheel, who had held his position right behind Hearne and was leading in the Hamilton County trophy race, lost its brilliant chance by breaking a connecting rod. The last accident was when the Schacht, driven by Jeffkins, was wrecked in its eightieth mile. A tire blew out on the left rear wheel where the road was soft

time, finishing 11 minutes ahead of the Cole. Burke, in the Cino, followed Hearne for the first four laps when he was put out from a broken connecting rod. Jenkins, in the Cole, was in seventh place for the first two laps. Then he commenced to spurt, passing Matthews, in the Ohio, on the third lap, and Harry Knight, in the Westcott, on the fifth lap. This put him into second place for the big race and first place in the little race, which position he held to the finish. In addition to his victory

FOR NON-STOCK CARS UNDER 600 INCHES, 200 MILES

9	10	11	12	13	14	15	16	17	18	19	20	21	22	23	24	25
75:39	84:08	91:22	99:24	107:28	115:38	123:55	132:04	140:39	149:27	159:04	167:31	175:59	184:30	192:52	200:45	209:03.20
8:28	8:29	7:14	8:02	8:04	8:10	8:17	8:09	8:35	8:48	9:37	8:27	8:28	8:31	8:22	7:53	8:18.20
78:50	87:12	94:25	102:37	110:53	120:00	128:36	136:47	145:19	154:01	166:29	177:26	186:13	194:38	203:05	211:38	220:04.27
8:20	8:22	7:13	8:12	8:10	9:07	8:36	8:11	8:32	7:42	12:29	10:56	8:47	8:25	8:27	8:33	8:26.27
80:32	88:23	97:14	105:56	114:34	123:11	131:45	153:44	164:56	173:29	182:03	190:36	199:06	207:34	216:03	224:39	233:38.75
8:41	7:51	8:51	8:42	8:38	8:37	8:34	21:59	11:12	8:33	8:34	8:33	8:30	8:28	8:59	8:36	8:59.25
90:42	100:08	109:20	118:39	127:52	137:07	146:38	155:47	164:42	173:34	182:22	191:14	200:04	209:22	218:21	227:19	236:11.58
10:01	9:26	9:12	9:17	9:13	9:15	9:31	9:09	8:55	8:52	8:48	8:52	8:50	9:18	8:51	8:58	9:00.58
85:37	93:56	103:22	112:50	122:29	132:00	141:49	151:24	161:00	170:45	180:29	190:05	204:59	214:22	223:47	233:06	241:59.60
9:38	10:19	9:26	9:28	9:39	9:31	9:49	9:35	9:36	9:45	9:44	9:36	14:54	9:23	9:25	9:19	8:53.60
83:28	91:38	100:46	109:56	118:39	127:35	136:11	145:18	154:27	162:55	171:19	Withdrawn, transmission trouble.					
9:16	8:10	9:08	9:10	8:43	8:56	8:44	8:59	9:09	8:28	8:24						

Withdrawn, wrecked.  
 ■ necting rod.

and the wheel broke. Both driver and mechanic were thrown out and Wilkie Meyers, the mechanic, received a cut on the leg.

From the beginning of the race Eddie Hearne in the big Fiat had everything his own way and was not really pushed at any



Ohio, No. 5, driven by Charles Thatcher, second in the small-car race

Jenkins had the honor of making the fastest lap of the day, negotiating the 7.9 miles in 7:13, an average speed of 65.7 miles per hour. Knight, in a Westcott, finished the first lap in the fourth place, then climbed up to third, and the accident to Burke put Knight into second place for one lap. Jenkins' spurt left Knight back in the third place until he dropped from third to sixth in the sixteenth lap, during a stop for oil, water and gasoline; then he climbed up to fourth place and the withdrawal of Thatcher, in the Ohio, put him into third place.

No. 6 Cino, with Gilchrist at the wheel, started out in the fifth place, dropped back to seventh in the third, and then was boosted to the fourth place by the withdrawal of the Schacht and the No. 7 Cino. In the sixteenth lap Gilchrist passed Knight and landed in fourth place, but was repassed by both Knight and Matthews in the next lap and finished in fifth place.

In the little race, which was decided by the position of the cars at the end of the nineteenth lap, neither the Fiat nor the Westcott was eligible, so that Jenkins, in the Cole, was leading from the fifth lap, and was closely followed by Thatcher, in the Ohio, throughout the race. Gilchrist, in the Cino, ran in third place nearly all the way. Thatcher immediately withdrew at the completion of the nineteenth lap on account of clutch trouble, declining to attempt to finish in the big race.



Scene at the start of the road races held near Cincinnati to commemorate the opening of the Fern Bank Dam across the Ohio River

The Cole came over the line a winner 5 minutes ahead of Thatcher, in the Ohio, who was 9:10 ahead of Gilchrist, in the Cino. The latter was spurring picturesquely on the last lap and was in a fair way to pass Thatcher when a tire was punctured by a spike on the road, but he finished third.

With the 150-mile race finished, the five racers continued the 50 miles still left in the 200-mile event. The Fiat was in the lead with the Cole close behind and Gilchrist in a Cino and Knight in the Westcott fighting for third place.

The race was very satisfactory from all points of view with, perhaps, two exceptions. One of these was the rather poor condition of the course, which was not well prepared for speedy work. As this was the first event of the kind it is probable that the promoters will make better road preparations for later events. The road had been well oiled, but was very soft in spots, a condition which was aggravated by the rains that occurred that morning. The policing of the track could have been very much improved upon. While there seemed to be plenty of the Ohio militia scattered around the course, there were not enough of the soldiers at the starting line, and their work in keeping the course clear during the races could have been more successful. It was necessary for the announcer on the judge's stand to notify the spectators that there was a car coming in order to awaken the militiamen to their duties. The policing of the course was a difficult affair at best, for both the electric and steam trains from the city discharged their passengers for hours during the races directly upon the side of the course in front of the grand stand, and there was no fence or other means of protection between the tracks and the race course. Not only did it require hard work on the part of the

guards to keep the track reasonably clear at this point, but the trains also obstructed the view of those in the grand stand. It was only by good fortune that many of the spectators were not killed or seriously injured, as some were running across the track in an irresponsible manner at all times.

There was one feature of the race that created comment among the officials, and that was the lack of stops for repairs, or for taking on gas and oil and water at the pits. There were only five stops at the pits during the entire four hours of racing, and only two stops for tire replacements. The first car to stop at the pits was the No. 4 Ohio which halted at the end of the ninth lap after running 91 minutes to replace with a new tire the one that had been put on at another point on the course. The next to stop was the No. 9 Fiat which drew up at the end of the eighteenth lap for one minute to take on oil and tighten up the shock absorbers. The only stop in which gasoline was taken on was when the Westcott No. 10 made a three-minute stay at the pits for oil, water and gasoline in the sixteenth lap. Water was taken on by No. 3 at the end of the twenty-first lap and it got away in 1½ minutes.

The following table shows the equipment of the contesting cars in the two races:

No.	Car	Carbureter	Magneto	Tires
2	Schacht	Schebler	Mea	Michelin
3	Cole	Schebler	Bosch	Michelin
4	Ohio	Schebler	Splitdorf	Michelin
5	Ohio	Schebler	Splitdorf	Michelin
6	Cino	Schebler	Remy	Michelin
7	Cino	Schebler	Remy	Michelin
8	Cino	Schebler	Remy	Firestone
9	Fiat	Fiat	Bosch	Michelin
10	Westcott	Schebler	Bosch	Michelin
11	Stutz	Schebler	.....	G & J
20	Colby	Rayfield	Remy	Michelin

TABULATION SHOWING STANDING OF CARS IN HAMILTON COUNTY TROPHY RACE, NON-STOCK, UNDER 300 INCHES, 150 MILES

Car & Driver	Time	1	2	3	4	5	6	7	8	9	10	11	12	13	14	15	16	17	18	19	
COLE.....Elap...	10:56	11:47	28:28	36:56	45:26	53:48	62:09	70:30	78:50	87:12	94:25	102:37	110:53	120:00	128:36	136:47	145:19	154:01	166:29		
Jenkins.....Lap...		8:51	8:41	8:28	8:30	8:22	8:21	8:21	8:20	8:22	7:13	8:12	8:16	9:07	8:36	8:11	8:32	7:42	12:29		
OHIO.....Elap...	8:55	18:08	27:53	37:12	46:22	55:39	64:56	74:12	83:28	91:38	100:46	109:56	118:39	127:35	136:19	145:18	154:27	162:55	171:19		
Thatcher.....Lap...		9:13	9:45	9:19	9:10	9:17	9:17	9:16	9:16	8:10	9:08	9:10	8:43	8:56	8:44	8:59	9:09	8:28	8:24		
CINO.....Elap...	9:34	19:00	28:48	38:26	47:57	57:12	66:29	75:59	85:37	93:56	103:22	112:50	122:29	132:00	141:49	151:24	161:00	170:45	180:29		
Gilchrist.....Lap...		9:26	9:48	9:38	9:31	9:15	9:17	9:30	9:38	10:19	9:26	9:28	9:39	9:31	9:49	9:35	9:36	9:45	9:44		
OHIO.....Elap...	9:38	18:56	28:34	37:56	47:17	56:21	65:46	80:41	90:42	100:08	109:20	118:39	127:52	137:07	146:38	155:07	164:42	173:34	182:22		
Matthews.....Lap...		9:18	9:38	9:22	9:21	9:04	9:25	14:55	10:01	9:26	9:12	9:19	9:13	9:15	9:31	9:09	8:55	8:52	8:48		
SCHACHT.....Elap...	11:44	20:43	30:32	40:06	49:27	58:50	68:11	77:28		Withdrawn wrecked.											
Jeffkins.....Lap...		8:59	9:49	9:34	9:21	9:23	9:21	9:17													
CINO.....Elap...	8:52	17:44	26:46	35:03	Withdrawn, broken connecting rod.																
Burke.....Lap...		8:52	9:02	8:17																	
CINO.....Elap...	Withdrawn, turned over.																				
Raimey.....Lap...																					
COLBY.....Elap...	Withdrawn, broken wheel																				
Pearce.....Lap...																					

## Fast Time at Hamline

**M**INNEAPOLIS, MINN., Sept. 11—Burman enjoyed a field day at the State fair automobile racing matinee Saturday. He made the fastest mile of the afternoon, 50 seconds flat, on a far from safe and sane track and was successful in defending his possession of the Remy brassard.

Heavy rains all week had placed the track in a treacherous condition. The surface appeared to be fairly dry, but below the top coating the fine soil of the track was soft and slippery. Soon after 8 o'clock in the morning the gates were thrown open, and the police rushed every motor car coming into the grounds out upon the track. Then began a long, tiresome milling of motors around the mile loop. Harrows stirred the soft mud and the process continued until nearly noon, when gasoline tractors from the exhibits of farm machinery were called into play to pull heavy drags. The surface of the track was literally pounded down by the multiple mileage of many machines. The stretches were in fair condition by noon, but the turns never dried out.

One feature of the meet which interested the spectators was an exhibition of speed driving with a tire change, as such changes are made in the big speed events, by Ray Harroun with the Marmon Wasp. This change, the taking off of a front tire and the replacing with a new tire, was accomplished in about 50 seconds. Harroun then drove out the remaining mile, making the three miles and the tire change in a total elapsed time of 4:45.

Charley Nyquist, in a Buick, won the second event, a 5-mile race, the time being 5:44 flat. Stubborn fighting marked the 15-mile race, one of the prettiest events of the day. In this event the Staver-Chicago withdrew on account of engine trouble, leaving the Buick and two Case cars to fight it out. Each had its turn in the lead, but the tenth mile found the white Case, driven by Jaggersberger, at the head of the procession, and it held that position to the end, with the Buick second. Time, 16:25 2-5.

Burman defended the Remy Brassard trophy successfully.

The final race, a five-mile handicap, free-for-all, developed some first-class handicapping. The Firestone went away first with a handicap of 50 seconds and the Cutting followed 10 seconds later. Nyquist sent his Buick away with 35 seconds lead over the scratch man and Heineman let the Case go five seconds later. Five more seconds elapsed, then the white Case car shot over the line with 25 seconds over the scratch car. The Hotchkiss was given 10 seconds to get clear of Burman and his Benz

at scratch. Burman started a terrific drive and on the third mile began overhauling the others, winning by a narrow margin.

McNay brought in the Cutting second with the Case, Jaggersberger, third, Heineman fourth, Kilpatrick fifth and Nyquist sixth. Burman's time from the scratch was 4:49 3-5. Summary:

Position	Car	Driver	Time
<b>Five Miles, Class C, Non-Stock, 231 to 300 Cubic Inches</b>			
1	Case	Jaggersberger	5:27
2	Case	Heineman	
<b>Five Miles, Class C, Non-Stock, 301 to 450 Cubic Inches</b>			
1	Buick	Nyquist	5:44
2	Cutting	McNay	
3	Firestone-Columbus	Sandell	
<b>Fifteen Miles, Class E, Non-Stock, 300 Cubic Inches and Under</b>			
1	Case	Jaggersberger	16:25 2-5
2	Buick	Nyquist	
<b>Exhibition, Three Miles with Tire Change</b>			
	Marmon Wasp	Ray Harroun	4:45
<b>Five Miles, Class D, Non-Stock, Free-for-All</b>			
1	Benz	Burman	5:06
2	Mercedes	Lee Oldfield	
3	Hotchkiss	Kilpatrick	
<b>Exhibition Mile (Track Record: 49 2-5)</b>			
	Blitzen Benz	Burman	First trial :50 3-5 Second trial :50
<b>Three Miles, Class D, Non-Stock, Free-for-All (Best Two in Three)</b>			
<b>For Remy, Grand, Brassard</b>			
<b>First Heat</b>			
1	Benz	Burman	3:01 2-5
2	Hotchkiss	Kilpatrick	
3	Mercedes	Lee Oldfield	
<b>Second Heat</b>			
1	Benz	Burman	2:53
2	Mercedes	Lee Oldfield	
3	Hotchkiss	Kilpatrick	
<b>Three Mile Exhibition Race</b>			
1	Marmon Wasp	Ray Harroun	3:58
2	Case	Lou Heineman	
<b>Five Miles, Class E, Free-for-All Handicap</b>			
1	Case	Heineman (15 sec.)	5:08 4-5
2	Case	Jaggersberger (Scr.)	
3	Buick	Nyquist (15 sec.)	
4	Cutting	McNay (10 sec.)	
5	Firestone-Columbus	Sandell (30 sec.)	
<b>Five-Mile Special Handicap, Class C, Non-Stock, 301 to 450 Cubic Inches</b>			
1	Firestone-Columbus	Sandell (40 sec.)	5:32
2	Buick	Nyquist	
3	Cutting	McNay (40 sec.)	
<b>Free-for-All Five Mile Handicap</b>			
1	Benz	Burman (Scr.)	4:49 3-5
2	Cutting	McNay (40 sec.)	
3	Case	Jaggersberger (25 sec.)	
4	Case	Heineman (30 sec.)	
5	Hotchkiss	Kilpatrick (10 sec.)	
6	Buick	Nyquist (35 sec.)	



View looking down the Fern Bank Dam course toward the press stand—the winning Fiat about to cross the line

## Short Items of News— Boston's Two Shows

BOSTON, Sept. 9—It is a settled fact now that Boston is to have two distinct motor shows, one for pleasure cars and the other for commercial vehicles. Some time ago the Boston Commercial Motor Vehicle Association voted that it would conduct such a show, but there was some talk about a change. The sending out of the application blanks for the regular pleasure car show, however, makes it clear that there will be a second exhibition for no provision is made for commercial vehicles. The pleasure cars will be exhibited in Mechanics' Building during the week of March 2-9, 1912, this being the regular period that the Boston Automobile Dealers Association holds its show. Then the week following the Boston Commercial Motor Vehicle Association will have its exhibition. As many of the dealers are members of both associations it will be an easy matter to turn from one show to another and Chester I. Campbell, who manages the motor exhibitions here each year, will be the man in charge of both next March. For the pleasure car show the diagrams provide for about 114,000 square feet space, but that amount will not be needed for the commercial show. With no business vehicles in the pleasure section it will allow a great many more exhibitors this season. In the past a number of dealers had no chance to get in and this led to abortive attempts from time to time to hold separate shows, but they were failures. The extra week for the commercial vehicles will now allow all types of wagons and trucks to be displayed, too, which was not possible in the past. And there will be no need of an annex now even though the agencies have multiplied a great deal in Boston since the last show.

### Seventeen Starters in Omaha Run

OMAHA, NEB., Sept. 11—The cars entered in the endurance run of the Omaha Motor Club for the World-Herald trophy, will leave at 6:30 A.M. to-morrow morning, on the four-day contest, intended as a dedicatory run over the newly improved North Platte route from Omaha to Colorado. The total mileage will be 656.9 miles.

The first night's stop is at Grand Island, 141.9 miles from Omaha; that on the second night being at North Platte, 168 miles farther. Returning, the cars will come back over the North Platte route to Kearney and then strike across to Hastings, the day's run being 174 miles. From here the South Platte route is followed to Omaha, going through Lincoln, the last day's run being 172.4 miles.

The following cars will start: No. 1, Lexington; No. 2, Ford; No. 3, Ford; No. 4, Ford, Glass & Evans, Grand Island; No. 5, Ford; No. 6, Velie; No. 7, Chalmers; No. 8, Kelley truck; No. 9, Case; No. 10, Maxwell; No. 11, Cartercar; No. 12, Marion; No. 14, Alco; No. 15, Paige-Detroit; No. 16, Paige-Detroit; No. 17, Lexington, and No. 18, Maxwell.

The pilot and Inter-State Auto Company official cars will be Inter-States, the Hupmobile, W. L. Huffman Auto Company, press car, a Hupmobile, and the judges' and press car, a Ford.

Ole Hibner is referee of the run, Otto P. Nestman chief observer, and George W. Coe chairman of the technical committee.

### Motor Exhibits at Milwaukee Show

MILWAUKEE, Wis., Sept. 9—Milwaukee motor car, motor, parts and accessory factories were well represented at the big Industrial Exposition held in the Auditorium, Milwaukee, from September 2 to 12, under auspices of the Merchants & Manufacturers' Association in commemoration of the fifteenth anniversary of its organization. The exhibits were confined to Milwaukee-made products and it was the first time an exposition of this kind was held in Milwaukee, which now ranks as the second largest manufacturing district in the United States. The Wis-

consin Motor Manufacturing Company exhibited a number of motors for trucks, pleasure cars and boats, including a six-cylinder, 50 horsepower motor, a 4-60 and a 4-45, in addition to rough and finished castings, crankshafts, etc. Other exhibitors in this line were: Davis Manufacturing Co.; Beaver Manufacturing Co. and A. O. Smith Co. The American Oxhydic Co., the Vilter Manufacturing Co. and the Western Fixture Co. exhibited welding and cutting apparatus. The Crown Commercial Car Co. was among the motor truck exhibitors. A feature of the display of The Falk Co. was a large one-cylinder kerosene engine which produced all power for lighting and working exhibits, and a number of sets of helical gear systems in operation. The Evinrude Motor Co. had a display of Evinrude motors which convert ordinary rowboats into launches or motor boats. The Milwaukee School of Engineering had a complete wireless outfit, together with a model airship, the motor of which was started and stopped by wireless nearly across the main arena of the Auditorium.

### Big Garage Fire in Boston

BOSTON, Sept. 10—A big garage fire started early this morning in the quarters occupied by Kenneth A. Skinner, who does a large garage and renting business, on Clarendon street. The fire started in one of the rear garage rooms from some unknown cause and before it was put out 45 machines were destroyed or badly damaged. Mr. Skinner estimated the loss first at \$150,000, but it is thought that this will be found to be too high when the cars are given a thorough inspection. He said that there were 50 machines in the building of which 40 were private cars, the rest being his renting cars. Only five machines were brought out, the fire made such rapid headway. The structure was formerly an old freight shed, and right behind it were the repair departments of several other motor concerns. It was thought that the fire would spread to these places and there was a rush to get the cars out of the buildings. In a short time the streets near the scene were filled with machines that had been run out and these also interfered with the firemen. Mr. Skinner was planning to move in a few days to the other end of the structure, to the quarters formerly occupied by the Winton company, and which had been vacated about a month. But for the fact that about 25 taxicabs which are garaged there were not due to be put up until about 3 in the morning the loss would have been far greater, as it would have been impossible to have gotten these out. Mr. Skinner said that his loss was covered by insurance, but he could not tell how many of the privately owned cars were insured.

### Iowans Visit Manufacturers' Plants

DES MOINES, IOWA, Sept. 9—C. L. Herring, Des Moines and Iowa agent for the Rambler and Ford cars, this week took 60 dealers from all over the state into the Detroit and Kenosha factories of the cars which the dealers handle.

At Detroit it was said that it was the biggest delegation of dealers which had ever been there from a single state. A 50-mile trip around Detroit and a banquet were among the entertainment features there and on the return trip Mr. Herring gave the dealers a dinner at the La Salle Hotel in Chicago.

The dealers in the party were J. E. Doze, Humeston; C. W. Bopp, Hawkeye; W. A. Wells, Sully; John Jons, Boone; George W. Bilbo, Creston; James F. Buxton, Creston; O. A. Repass, Dallas Center; B. O. Bufkin, Runnells; F. Sweitzer, Hudson; E. J. Miles, Newton; Charles D. Booth, Harlan; H. J. Van Vliet, Pella; S. E. Huff, Afton; A. H. Dale, Des Moines; Edward Van Gorp, Pella; H. S. Petty, Elliott; Dale Smith, Indianola; Harris Thornton, Ankeny; Charles C. Norton, Avoca; A. C. Ware, Oakland; W. H. Fowler, Pella; A. S. Workman, Glenwood; H. J. Lytle, Ottumwa; S. Schacht, Lime Springs; T. A. Mitchell, Council Bluffs; Bert Sanford, Atlantic; D. P. Hogan, Massena; L. L. Bybee, Knoxville; G. I. Coffman, Kinross; D. N. Hunt,



Osceola; L. A. Shearer, Montezuma; C. L. Seibel, Thayer; D. E. Moon, Birmingham; George De Mose, Germanville; George F. Taglander, Brighton; F. G. Hinegardner, Toledo; W. J. Courtney, Cedar Rapids; W. E. West, New Hampton; J. G. Herring, Atlantic; Lewis Scheller, Kellerton; John Connelly, Greenfield; Charles Robinson, Villisca; W. L. Morrison, Conway; C. A. Delano, Lone Tree; W. P. Brauch, Marengo; John R. Rude, Perry; Perry C. Rude, Perry; John Mace, Allerton; C. A. Bishop, Bedford; M. A. Gifford, Lewis; David Burkett, Dallas Center; J. P. Bowen, Ottumwa; A. Mickel, Walnut.

### Chicago's Contest Happenings

CHICAGO, Sept. 11.—Next on the Chicago Motor Club's calendar is the commercial motor vehicle demonstration which is set for Monday, Tuesday and Wednesday of next week. This will not be a contest but a demonstration in keeping with the desires of the truck makers, consisting of out and home runs of around 60 miles a day, each truck carrying its scheduled load. The total distance to be covered in the three days will be 159 miles. If the entry list warrants it, a horse-drawn vehicle will be sent out also over the same routes in order that comparisons may be made, the horses being required to go the entire distance even if it takes a week. The entries at present number twelve, but it is thought there will be at least twenty-five start. Those in at the present time are three Clarks, two Saurers and one each of the Alco, Buick, Old Reliable, Little Giant, La Moop, and Swanson.

Already an official report on the Elgin race attendances has been made by Philip Freiler, treasurer of the Elgin Automobile Road Racing Association. According to Mr. Freiler the association collected 14,007 general admission tickets the first day and 28,002 the second, while the parking space returns show 1354 cars the first day and 2480 the second day. The association distributed \$10,200 among the 75 farmers who own property around the course for their share of the receipts and on the guarantee that was made them. In addition to this the farmers received \$4,500 for work which they did on the road. An interesting item was the sum of \$10,500 which was spent by the Elgin association for widening, oiling and repairing the racing circuit.

### Baltimore's Last Toll Gate Doomed

BALTIMORE, MD.—The old toll gate on the Reisterstown road, near the northern entrance to Druid Hill Park, the only one left in the city, is now doomed to go. At a meeting held in the City Hall last Thursday the officials of the Reisterstown Turnpike Company agreed to accept \$70,000 for the portion of the roadway within the city limits.

### The Ostende Meeting

The races organized by the Automobile Club of Ostende, held over the Ostende-Nieuport-Snaeskerke-Ostende circuit on September 3, were very successful. The weather was favorable and the crowd that turned out to witness the racing was amply repaid. Next year will see not only a repetition of the races, but also a competition for commercial vehicles.

Four different events were run off, the mileage covered in three of the events being 207 miles, and in the other 248.5 miles. Three of the races were won by Lion-Peugeot cars and the results were as follows:

Coupe de Liederkerke, 248½ miles; winner, Fendu; driver, Veraeren; time, 6 hours 12 minutes 55 seconds.

Coupe d'Ostende and Coupe Williams, 207 miles; winner, Lion-Peugeot; driver, Boillot; time, 3 hours 28 minutes 33 seconds (average, 60.8 miles per hour). Second, Excelsior; driver, Coosemans; time, 3 hours 55 minutes 55 seconds.

Coupe des Voiturettes, 207 miles; winner, Lion-Peugeot; driver, Goux; time, 3 hours 52 minutes 38 seconds.

## Memos From All Points— Latest Contest News

DENVER, COL., Sept. 11.—The second annual Chalmers Owners' Consistency tour will be run on September 14 and 15, 1911, starting from the McDuffee Motor Company's salesrooms, 1517 Tremont Place, at 8.30 A.M. The management has taken great pains to provide everything necessary for the participants in the tour and ladies are especially invited to compete for the Chalmers trophy. The contest is not one of speed but of efficient car management.

SYRACUSE, N. Y., Sept. 9.—Motorists of Syracuse and Central and Northern New York are on the *qui vive* for the most pretentious race card ever offered locally, scheduled for Saturday, Sept. 16, the closing day of the New York State Fair, upon one of the fastest mile circular courses in the country and with President Taft as the guest of honor. Vice-President Sherman will also probably be here. Burman, in the Blitzen-Benz, will be one of a famous list of visiting drivers. He will endeavor to lower his mile world's record of 48.72 seconds on a circular track. Burman figures his opportunity is here, since drivers regard the Syracuse track as the fastest mile dirt track in the country.

GREENSBORO, N. C., Sept. 9.—The Greensboro Automobile Club has just been organized with a membership of 35—and good prospects for 100 or more. The officers are as follows: C. M. Van Story, president; Dr. J. T. J. Battle, vice-president; M. W. Thompson, secretary, and R. C. Bernau, treasurer.

The main object of the club is the promotion of good roads. The Glidden Tour is expected to pass through this city. If the schedule makes this city a night stop, the cars will be housed in the Auditorium. The county (Guilford), it will be remembered, captured the Good Roads prize of \$1,000 in November, 1909, offered by the *Atlanta Journal* and *N. Y. Herald*.

MILWAUKEE, WIS., Sept. 9.—The Milwaukee Automobile Club entertained 560 orphans, the largest number since it inaugurated an Annual Orphans' Outing day, on September 7, more than 100 touring cars being donated by members to carry the little unfortunates from the asylums to Washington Park, where a lunch was served on the grass. Frederick Gettelman was chairman of the outing committee and W. H. Pipkorn, through whose efforts the outings were first arranged and continued, acted as chief marshal. The supplies were transported in three trucks, a Stegeman, a White and a Pierce-Arrow. Mrs. Gustav G. Pabst, wife of the president of the Pabst Brewing Company, donated all ice cream and cakes, as has been her custom in past years.

### Indianapolis Abandons Grade Crossings

INDIANAPOLIS, IND., Sept. 11.—This city within the next few weeks will begin the abolition of all railroad crossings at grade in the central part of the city. It is the intention to let contracts for the entire work at one time, and it is believed that within three years all grade crossings in the center of the city will be eliminated, leaving grade crossings only on the outskirts.

Henry W. Klausmann, city engineer, is now engaged in preparing plans for the work, which, it is estimated, will cost approximately \$6,000,000, and work will start by January 1.

Under the law the railroad companies must pay 75 per cent., the city 16 per cent. and the county and street railroad company the remainder. At the last session of the Legislature the city was authorized to levy a special tax of 6 cents on each \$100.

### Rain Kills Hartford Races

Rain and bad weather at Hartford, Friday night, caused the abandonment of the race meeting that was scheduled to be held at Charter Oak park on the final day of the Connecticut State fair. Quite a program of races had been arranged with a number of local entries.

## S.A.E. Prepares for Active Winter

FOR the first time in its history the S. A. E. is planning a foreign trip. Indications point to a possible participation in the trip of about 100.

The members of the S. A. E. will leave this side of the water for England about November 1st. The first few days in England will be spent in examining the exhibits of the automobile show which will then be in progress at Olympia, London. The visiting engineers will be entertained by the Incorporated Institution of Automobile Engineers, which is the English Society corresponding to the Society of Automobile Engineers.

A trip will be made to Birmingham to see the factories of the Austin Motor Company and the Wolseley Motor Car Company as well as to Coventry to go through the plant of the Daimler Motor Company.

A run through some of the interesting country in the Warwickshire district, Stratford-on-Avon, and surrounding territory, has been arranged.

The Humber automobile factory, one of the largest in England, will also be visited.

It is planned to devote an evening to joint technical discussion by members of the Institution of Automobile Engineers and the Society of Automobile Engineers.

The S. A. E. members will be shown around the garages of one of the big London cab companies, and perhaps the plant of the London General Omnibus Company.

The party of engineers will probably go also to Newcastle-on-Tyne to see the Armstrong-Whitworth factory.

The Brooklands track will be visited, some racing cars being brought specially for the occasion.

The American motor car designers and producers will make a short trip to France to see some automobile factories there.

Autumn and winter schedules of meetings of the Society of Automobile Engineers have been announced. At a meeting of the society council held last week it was decided that the annual meeting of the society shall be held in New York City, January 18, 19 and 20. This is during the commercial vehicle division of the automobile show at Madison Square Garden. Scientific papers will be presented and discussed, as well as reports of the standards committees; and officers for the ensuing year will be elected.

The Philadelphia branch of the society held a meeting at the Engineers' Club in Philadelphia, September 13.

On September 28 the Metropolitan section of the S. A. E., in its session at 1451 Broadway, New York City, will discuss slide, rotary and piston versus poppet valves for gas engine service, and novelties in valve construction. Also brake-horsepower developed by automobile motors of various current sizes.

The next meeting of the Detroit section of the S. A. E. will be held in Detroit on Thursday, October 5.

First of the committee meetings ordered at the Dayton convention of the Society of Automobile Engineers, with reference to the Iron and Steel Division of the Standards Committee, was held recently at the headquarters of the organization at Broadway and Forty-first street.

This division has been in the habit of making semi-annual reports incorporating specifications for plain and alloyed steels and irons used in automobile manufacture, but at the Dayton general meeting it was determined to instruct the committee to take some further action than was incorporated in its accepted report.

The chief matter under discussion was as to whether chemical specifications or appropriate physical qualities should be the rule in ordering steel. Whether the buyer should specify the constituent alloys to enter into the manufacture of the steel or-

dered or whether he should state the purpose for which the steel was to be used and specify that it must have certain physical qualities rather than a fixed chemical composition.

The steel men insist that if a buyer specifies a certain chemical composition he should not incorporate into his order that the steel shall have certain qualities or vice versa. The position of the Iron and Steel division is that the chemical formula has the most apparent advantages.

At the recent meeting of the division the following were present: Henry Souther, Consulting Engineer, Chairman; W. P. Barba (Midvale Steel Company); E. L. French (Crucible Steel Company of America); F. W. Trabold (J. H. Williams & Company); Howard E. Coffin (Hudson Motor Car Company); M. T. Lothrop (Halcomb Steel Company); George L. Norris (American Vanadium Company); H. B. Bent (Pennsylvania Steel Company); S. V. Hunnings (American Locomotive Company); Joseph Schaeffers; A. R. Gormully (United States Motor Company); Thomas Towne (Union Drawn Steel Company; New York State Steel Company); Coker F. Clarkson, Secretary.

### Glidden Pathfinder En Route South

With the start of the Pathfinding Flanders car from this city on the afternoon of Friday, September 8, the Glidden Tour took on a new air of importance. The car has since then been making good headway and on Monday had reached Roanoke, Va., on the trip. Two days will be spent at Atlanta, Ga., and Jacksonville, the objective point of the trip, should be reached September 19.

The first day's trip was to Philadelphia; Saturday night Gettysburg was reached; Sunday night the car had reached Staunton, and next day it was in Roanoke. The roads to Philadelphia are good, the only trouble being the necessity of procuring Jersey licenses. Between Philadelphia and Gettysburg the chief difficulty will be in the toll-gate charges, \$4.75 being the maximum amount for a single car between these cities. The roads from Philadelphia to Gettysburg are excellent with the exception of the last 10 miles, which is a worn-out pike. From Gettysburg to Winston-Salem, N. C., the roads are also good.

Owing to the change of the dates of the tour and its conflict with the 1600-mile Reliability Run of the Chicago Motor Club it was impossible for David Beecroft, the referee officially selected to officiate, and P. J. Walker, member of the Contest Board, San Francisco, Cal., has accepted the position of referee.

To date 40 entries have been received. Of these 11 are factory entries, made up as follows: Maxwell, three cars; Flanders, three; Metz, three; Halladay, one; and McIntyre, one. The remainder of the entries are private owners who live in Atlanta, Ga., Jacksonville, Fla., and other Southern cities. Entries close October 1.

### Chicago Dealers' Open-House Week

CHICAGO, Sept. 11.—The Chicago Automobile Trade Association has decided definitely to stage its fall opening from September 30 to October 7 inclusive, a period of eight days, in which time the dealers will keep open house, displaying their 1912 models and decorating the row. It is planned to illuminate the street at night by means of strings of incandescents and each dealer is supposed to keep open evenings. Plans for financing the show call for assessing each dealer according to his frontage, the car dealers occupying the first floor paying \$2 a foot, with a minimum charge of \$5. Those on side streets are to pay 75 cents a foot. This, it is thought, will raise a fund that will enable Chicago to make a proper display.

# Peeps Thro' Goggles at Distant Lands

## What the Foreigners Are Doing in Automobiling

*Items of interest, gathered here and there in foreign countries, having special reference to the activities of motorists. Motoring in Italy; Irish improving roads; Canadian touring; Scotch oppose radical legislation; unique joy-ride case; English medicos take to the automobile.*

**M**OTORING in Italy affords some of the most enjoyable moments of the automobilist's series of tours. This is particularly the case when the route includes Florence; Urbino, the city of Raphael; Bramante and the gorgeous Frederico di Montefeltro; Perugia and Orvieto in Siena; lovely Montepulciano; Volterra, and other small hill towns of Tuscany and Umbria.

The Irish Roads Improvement Section of the Automobile Association and Motor Club is doing an amount of work that is winning praise from the country people. The section's work includes the advancement of reforms in the methods of constructing and maintaining the roads. Incidentally, the section is making a persistent effort to mitigate the very bad habit of patching roads with metal of unseemly proportions.

There are now several hundred automobilists in the Island of Java, about 500 machines having been imported into the Island in 1910. The Java Motor Club has the credit for accomplishing splendid work in the matter of establishing petrol depots in several sections of the Island.

There is not a finer drive in all of Canada than the roads found in Nanitoulin Island, which lies at the head of the Georgian Bay. These highways stretch over hundreds of miles. And yet there is not a single automobile on the island, nor is there a tram car line or a railway. But it is timely to say that the denizens of the island are by no means happy over the existing conditions of transit, as they lose days in travel while on business errands, horse-drawn vehicles being the only accommodation afforded. These people are seeking a means by which automobiles may be introduced into the island. Nearly all of the goods consumed are supplied by commercial travelers who wend their weary way over the island. There is a field there for passenger and freight motor cars, even though the market is limited.

Simcoe, Grey and Bruce Counties in Owen Sound are the fortunate possessors of splendid roads. A certain cement quality in the gravel and stone makes the highways quite equal to macadamized roads. Although there are but six motor cars in Owen Sound owned by private individuals, and one automobile for public hire, scores of touring parties head for Georgian Bay Summer resorts during the season and a great many automobiles are to be seen. One touring party made the distance of 162 miles from Niagara Falls to Owen Sound within the space of seven hours. They reported the roads as being in excellent condition, and as improving until they reach the bay. There are 200,000 inhabitants residing in the Owen Sound district, the towns including Markdale, Derham, Harriston, Hanover, Chesley, Southampton, Wiarton, Meadford and Collingwood. A big opening exists in that section of the country for passenger and freight automobile service, the towns now being wholly dependent upon teams to supply the local traffic. Owen Sound finds it impossible to take care of its trade without the aid of automobiles, for business men are chronically behind in their deliveries in spite of the fact that eighteen livery establishments are maintained there. The only months that the snow proves a serious impediment are from January to April. The remaining nine months of the year are favorable to automobile service. The people of the

country are beginning to ask if it is not wiser to adopt motor cars for passenger and freight service than it is to depend upon the two lame railway lines which are now in commission.

It has been decided to hold the next International Automobile Show in Berlin, from the 12th to the 22d of October. This will be the first exhibition of the kind given in Berlin since 1908.

Scotland is taking good care that her East and West Coast automobile routes are being admirably patrolled. Men are employed on duty continuously. Handbooks are published enumerating the location of all patrols, as well as the address of the nearest road-agent, in case repair parts are required by automobilists using the road.

The Legal and Legislative Committee of the Scottish Automobile Club declares the association opposed to the Motor Traffic Street Noises Bill recently introduced locally. The committee base their antagonism on the ground that automobile owners would be put to great inconvenience were they to comply with one of the most signal provisions of the bill, namely, that compelling a uniform type of horns to be used.

The miraculous growth of the Royal Automobile Club of London is a subject of general discussion throughout Europe. Applications for membership reached 1,483 in number during July.

A case in London recently came to trial where a chauffeur had taken out his employer's automobile for the purpose of indulging in a "joy ride"—the term was used in the Magistrate's court. At the end of the day in question the employer discovered that the chauffeur had used up an amount of gasoline sufficient to run the car one hundred miles. Determined that he would make an example of his driver, the employer caused him to be arrested on a charge of larceny of the gasoline. When the case came up in the police court the chauffeur was given the choice of being dealt with summarily or going for trial at the Sessions. The chauffeur took advantage of the latter prerogative. Without hearing any statement of the important points involved or listening to a hearing by the Court, the Grand Jury threw out the bill and the chauffeur went free. But this was not all. The Presiding Judge in endorsing the action of the Grand Jury compared the chauffeur's act of appropriating the gasoline with that of a groom feeding his employer's horse with his employer's oats, thereby exonerating the chauffeur.

English medical practitioners have gone in for automobiles to a great extent within the last twelve months. But in order that they may ascertain if the motor car is an economical factor compared with the old horse-drawn shay these doctors have indulged in some demonstrations. They have found out that the average cost of operating a 15-horsepower machine is but a little more than one cent per mile in excess of running a 6 to 8-horsepower motor car. They proved that the expense of operating a 20-horsepower machine is less than two cents a mile in excess of the average cost of running a small, single-cylinder vehicle. The average fuel consumption of a 15-horsepower machine proved to be one gallon for twenty miles, the same measure supplying a 25-horsepower car for a distance of seventeen miles. The doctors say these figures are less than the expense of keeping a horse.

# From Springs to Hard Coal Mines

## An Ideal Autumn Tour for Novelty Seekers

*How the automobilist may spend a few days in a rather unusual tour from the splendid resorts of New York and New England to the Anthracite region of Pennsylvania with all its richness and squalor and its foreign appearance and interesting details. The trip as scheduled is for three days' running time, but it should take four and ought not to be condensed into two.*

**T**HERE is a constant demand from motor tourists who are spending the early Autumn in the New York hill counties or at the New England resorts for something in the line of diversion. To such an automobile tour from, say,

issue of the *Blue Book*. Ballston is the first town of any size to be met. The first five miles is over excellent macadam which leads into a good dirt road two miles before reaching Ballston. The country through which this part of the route goes is strik-

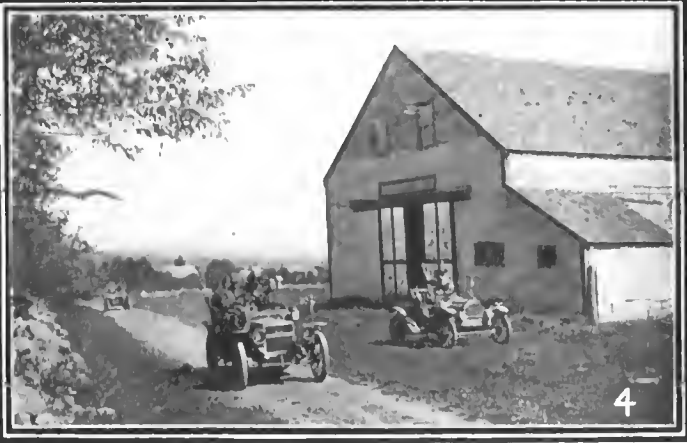

1—Riding over millions of tons of anthracite  
2—Beginning the climb from Binghamton to Wilkes-Barre

3—A typical country lane in Central New York  
4—Approaching the Susquehanna River near Harrisburg

Saratoga through Southern New York into Pennsylvania, and a swing around through the mountains of that State may serve the purpose of affording a little variety to the vacation.

There are numerous routes that may be followed, but the pleasure of such a tour is measured largely by the absence of difficulties to be encountered, and good roads and adequate hotel accommodations are among the things most devoutly to be desired. As the routes selected for the purposes of this article have been mapped out by the *Automobile Blue Book* and indorsed by the Touring Club of America it may be assumed that the tour will be over the best roads afforded by the sections traversed.

Starting from Saratoga the party will find an excellent route as far as Amsterdam in Route 229 of Volume 1 of the current

ingly beautiful and varied in its scenic setting and will be long remembered as a beautiful picture. Charlton, a small hamlet, is about eight miles farther along, and shortly after passing the village one of the worst stretches of road on the trip will be found. This, however, is not long, and after it is passed the roads will be found to be excellent except for some rather trying water-breakers after passing Glenville. From there to Amsterdam the road is macadamized and is in fine condition. The mileage to Amsterdam is 28.9.

At this point a change to Route 77 is advisable in order to travel for a distance on the main truck road up the Mohawk Valley to Herkimer. The roads out of Amsterdam are finely improved and the way passes Aiken Station, Fonda, Yost's Sta-

tion, Palatine Bridge, St. Johnsville and Little Falls before reaching Herkimer. This is 49.6 miles from Amsterdam, practically all of which is over improved roads. A left turn is made at Herkimer and a short run brings the party to Cooperstown.

From Cooperstown to Oneonta the proper route to follow is Route 289A, passing through Milford, Portlandville, Milford Center to Oneonta, a mileage of 12.4, making a total mileage for the tour so far of 96 miles. If the start from Saratoga has been early, this is a good place for the midday meal and rest, for there are several excellent places of refreshment for the members of the party and the car at Oneonta.

The first hour of the morning trip will be found to be the hardest and at the same time the pleasantest of the run, but every minute will be enjoyed.

The afternoon start may be delayed until 3 o'clock if desired, because the rest of the day's run into Binghamton is only 61.4 miles by Route 301. This takes the party down the valley of the upper reaches of the Susquehanna River and through a delightful Summer resort region. The chief places to be passed are Otego, Wellsbridge Station, where the Susquehanna is crossed, Unadilla, a noted resort, Bainbridge, Afton, Nineveh, Harpurs-

are narrow and crowded with children, something like the East Side of New York City.

Out from Binghamton the way leads upward via Route 361R of Volume 3 of the *Blue Book*. This route passes through Kirkwood, N. Y., and crossing the Pennsylvania State line touches Great Bend, New Milford, Harford, Glenwood, Fleetville, Wallsville, Waverley, Clark's Green, Clark's Summit and Providence into Scranton. This is 59.3 miles from Binghamton and has some heavy hills and a few rough spots in the roads, which are not sufficiently long to be annoying.

From Scranton to Wilkes-Barre is 17.8 miles via Route 365 of the same volume. This is the hard-coal region proper and there is nothing like it on earth. The millions of tons of anthracite that have been mined and used in the past constitute only a fraction of the wealth that still lies below the surface of the blue hills awaiting the call of the miner to serve a useful purpose in the advancement and comfort of humanity.

The road touches Hyde Park, Taylor, Old Forge Station, Duryea, Pittston Junction Station, Pittston, where a good macadam road is picked up into Wilkes-Barre.

Considerable time ought to be devoted to this day's run as



5—A fine bit of road near Oneonta, N. Y.  
6—In the heart of the anthracite region

7—Before meeting the State road into Binghamton  
8—A Glimpse of the Susquehanna near Wilkes-Barre

ville, Belden, Sanitaria Springs and Port Crane into Binghamton.

The roads are generally good and there should be no difficulty in reaching the objective point of the day's run by 6 o'clock. Binghamton has a number of creditable places of entertainment.

The second day's run will give the party a taste of hill climbing into the heart of the richest anthracite country in the world which lies between Wilkes-Barre and Scranton, Pa., high in the Alleghenies. It is almost like a trip to Poland or Hungary to traverse the coal mining towns of this section. Plain English is understood only by the children and a few adults and the character of some of the places is very similar to that of villages under the flag of Kaiser Wilhelm and the Emperor Franz Josef, to say nothing of Czar Nicholas. The streets in these villages

the grades are pretty stiff in spots and the roads are not marvels of construction. Then, too, a leisurely inspection of the anthracite region will repay all the time spent upon it. Besides these things, some of the scenery along the way rivals anything in the eastern part of the United States in rugged beauty and sylvan richness.

The third day of the trip is to Harrisburg, the capital of Pennsylvania, and, via Route 391, this is 108.8 miles through the heart of the Alleghany Mountains. It follows the valley of the Susquehanna River to Bloomsburg, Danville, Northumberland, Shamokin Dam, Port Trevorton to Harrisburg.

From Harrisburg the tourists may pursue any of a dozen different directions and can return by varied routes.



# Stresses and Strains in Tires

## Part I.

Translation of an article by Henri Petit, in *La Technique Automobile et Aérienne*

THE duty that the pneumatic tire—the connecting link between the car and the ground—has to perform, is very complex. So complex is it that no one has yet been able to completely analyze it, at any rate not sufficiently in order to be able to reconstruct an integral synthesis from the resultant analysis so as to evolve the elastic wheel.

It is possible to state affirmatively that the moment that anyone has discovered the exact manner in which the pneumatic cushion of an automobile wheel works, then the problem of the elastic or resilient wheel will be three parts solved.

It is not the intention here to solve the complex rôle of the pneumatic; the object of this article is more modest. It is proposed to show the nature of the efforts supported by the tires, their approximate direction in the order of sizes.

The proposed study about to be indulged in will not prevent tires from wearing out and bursting to the great despair of the owner. But it will allow him to get an insight into the different phases and multiple causes of wear and premature destruction.

The chauffeur will be able to see where his personal co-efficient comes in, and consequently be in a better position to give the tires all the cares that are dependent upon him in order to prolong their useful existence.

It is proposed to classify the efforts to which the tire is submitted in static efforts (these are the efforts that act upon the tire when the car is standing still) and dynamic efforts, that is to say, efforts that are caused by the diverse movements of the car.

### Static Efforts

It is presumed that the reader knows how a pneumatic tire is made, and in the following article it will be presumed that the inflated tire presents geometrically the exact form of a torus.\* This hypothesis is as near to the truth as it is possible to go and in every case the errors that may be made in adopting it are much less than approximation that we hope to attain.

It will be remembered that  $R$  is the mean radius of the torus,  $r$  the radius of the meridian circle. The dimensions by which tires are usually denoted are expressed by

$$2(R+r) \text{ (diameter of the parallel equator)}$$

and

$$2r \text{ (diameter of the meridian).}$$

Supposing  $p$  to represent the difference in pressures (expressed in kilog per square centimeter) between the air enclosed in the inner tube and the atmospheric air.

The figure  $p$  will be the reading on a manometer or pressure gauge applied to the valve.

$p_0$  will denote the initial pressure to which the tire was inflated, or to be more exact we will call  $p_0$  the value that  $p$  will take when the tire is not opposed to any exterior effort, the temperature of the air inside being the same as the exterior air at the moment of inflation.

$p_0$  will therefore be the theoretical pressure indicated by the makers, which are given as a guide for inflating tires.

Finally we will admit for the calculations of tensions supported by the canvas, that

1. That the tire is perfectly souple.
2. That the canvas does the work, the rubber of the inner tube and outer cover not supporting any effort.

\*A surface described by a conical section, a circle rotating about a straight line in its own plane. A solid of revolution included in such a surface sometimes called anchor ring or simply ring.—Webster.

3. That the canvas known as straight grain included in the arc are not affected by the effort due to the internal pressure.

### Superficial Tension

One knows that an elastic membrane separating two gaseous masses, the pressures of which are different, supports an effort of traction which is a component of the differences in pressure and of the curvature of the membrane.

If the radii of the principal curvatures are designated by  $r'$  and  $R'$  at any point of the inflated tire the surface tension will have a value at this point

$$A = \frac{P}{\frac{1}{R} + \frac{1}{r}}$$

It is interesting to note the variations of the radii of the principal curvature of the torus at the different points of the surface.

The minimum radius  $r'$  is evidently equal to the constant value of the meridian circle.

$$r' = r$$

The radius  $R$  maximum will vary according to the different points of a given meridian.

It will be as well to give it a positive value (in the same manner as  $r'$ ) when the curvature will have its concavity turned toward the interior. Taking Fig. 1 as an example denoting a meridian section of the torus.

At the point A we have

$$R' = R + r$$

Considering the displacement from A to B the curvature diminishes until it becomes nil at B.  $R'$  will grow indefinitely from A to B while remaining positive.

In displacing from B to C the curvature becomes negative and augments the absolute value. The radius of the curvature varies from  $O$  to

$$-(R-r)$$

The surface tension  $A$  varies therefore between the two values

$$\frac{p}{\frac{1}{r} - \frac{1}{R-r}} + \frac{p}{\frac{1}{r} + \frac{1}{R+r}}$$

and

It is easy to see that the maximum will be at the point C. In fact the denominator is maximum when  $R'$  is negative and equal to  $R-r$ .

The maximum surface tension is therefore

$$A_M = \frac{p}{\frac{1}{r} - \frac{1}{R-r}} = p \frac{r(R-r)}{R-2r}$$

It will be interesting to see how this compares with different

sizes of tires. First of all it should be noted that R is always much greater than r. We have therefore for the current dimensions of tires of cars the following:

For casings:

700 × 90	R = 30.5 cm.	r = 4.5	$\frac{R}{r}$ = about 7
			$\frac{R}{r}$ = " 7.5
			$\frac{R}{r}$ = " 9
790 × 90	R = 38.5 cm.	r = 4.5	$\frac{R}{r}$ = " 6
			$\frac{R}{r}$ = " 6.8
			$\frac{R}{r}$ = " 5.5
820 × 120	R = 35 cm.	r = 6	$\frac{R}{r}$ = " 6
			$\frac{R}{r}$ = " 6.8
			$\frac{R}{r}$ = " 5.5
895 × 135	R = 38 cm.	r = 6.8	$\frac{R}{r}$ = " 5.5
			$\frac{R}{r}$ = " 6
			$\frac{R}{r}$ = " 6
990 × 90	R = 41 cm.	r = 4.5	$\frac{R}{r}$ = " 9
			$\frac{R}{r}$ = " 6
			$\frac{R}{r}$ = " 6

The pressure p to which tires should be inflated varies, as everyone knows, with the diameter of the tire. That is why tires of 90 millimeter section should be inflated to 5 kilogrammes, 120 m.m. section to 6 kilos and 135 m.m. sections to 7 kilos.

It is easy to see how far the same section and also for the same pressure the maximum surface tension will vary.

It is expressed by

$$A_M = p r \frac{R - r}{R - 2r}$$

$$A_M = p r \frac{R}{R - 2r}$$

For the same section the product p r is constant.

The fraction

$$\frac{R}{R - 2r}$$

$$\frac{R}{r}$$

is greater than unity, and will decrease when r

increases. From which it is possible to draw the following conclusion:

The surface tension is proportionately smaller for

a given section of the tire as the diameter of the wheel increases.

If we consider the various sections of casings we can find out that the surface tension is proportionately greater as the tire increases in size.

In fact, in the product

$$A = p r \frac{R}{r}$$

the term p will increase when r increases.

This table will show that  $\frac{R}{r}$  diminishes when r increases.

$$\frac{R}{r}$$

The three factors p, r,  $\frac{R}{r}$  will increase with r.

$$\frac{R}{r}$$

That is why a 700 × 90 tire will have a superficial maximum tension:

$$A_M = 5 \times 4.5 \frac{7 - 1}{7 - 2} = 27 \text{ kilogrammes.}$$

A<sub>N</sub> 875 × 135

$$A_N = 7 \times 6.9 \frac{5.5 - 1}{5.5 - 2} = 61 \text{ kilogrammes.}$$

It is for this reason that tire makers manufacture the tires with a proportionately greater number of layers of canvas as the diameter increases.

Ninety millimeter section tires usually have 4 layers of canvas, while 135 m.m. sections have 7 layers of canvas.

The proportion indicated by the calculation does not seem to have been followed. This is accounted for by the fact that in all tires efforts independent of the diameter must be taken into

consideration, which will be explained later. So that if the number of layers of canvas to be used is denoted by n and a the tension to support each one of them, n must be calculated from the formula

$$n = \frac{A}{a}$$

which would seem rational if the surface tension were not taken into consideration, but it must be calculated from the following:

$$n = n_0 + \frac{A}{a}$$

(To be continued)

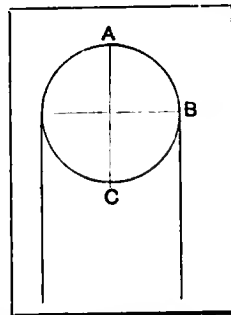

Fig. 1—Diagram denoting the meridian section of the tire

## Harking Back a Decade

THE American Bicycle Company is preparing to move its headquarters for motor vehicles from Toledo, Ohio, to New York City.

The Crestmobile, long since relegated to the lumber room of the past, comes into the limelight by virtue of an announcement that, owing to costly improvements incorporated in the new model, \$50 had been added to its selling price of \$500.

The New York-Buffalo endurance test, with its seventy-seven entries, of which twenty-six were steamers, occupies not a little space in the secular and trade press.

Commercial vehicles are doing stunts, as is evidenced by an account of a Locomobile delivery wagon climbing Nelson's Hill

(north of Peekskill) without a stop, despite its 800-pound load.

Editorials have much to say regarding the stopping of the Newport races, the general tone of the comment being hostile to the motorists and favorable to those who succeeded in spoiling the proposed sport.

This week ten years ago a party of tourists from the Chicago Automobile Club were on the road en route to the Pan-American Exposition at Buffalo.

A writer in *The Motor Review* of August 12, 1901, deprecates the practice of crossing the spokes in the effort to attain rigidity in wire wheels, such procedure, in his opinion, hastening the disintegration of the wheel.

# The Upkeep of the Car

## When the Owner Is His Own Repairman

*The automobile enthusiast derives a large proportion of his enjoyment from a thorough acquaintance with every part of his automobile. This knowledge is only picked up by doing the repair work which lies within the scope of the garage, whether it be upon the motor, chassis or body of the automobile.*

FOR the automobile enthusiast who lives out of town, or in such a location that he is able to have his own private garage, nothing furnishes such a great diversion as attending to the needs of his car. In the same manner as the average amateur photographer finds half his enjoyment in the

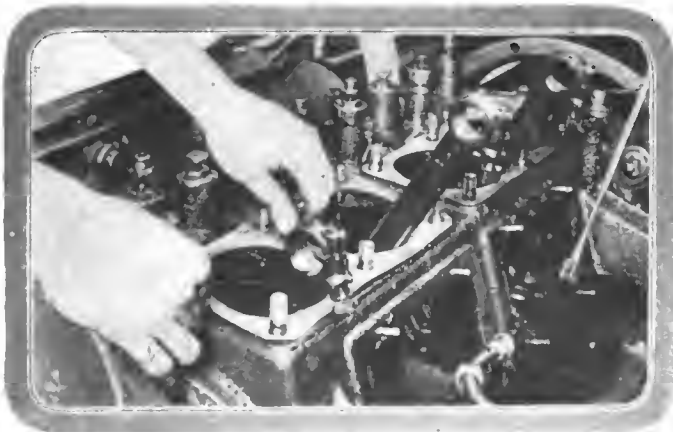

Fig. 1—Illustrating method of fitting gasket between cylinder and crankcase castings

making of his own pictures, so does the average automobilist, who has entered the game for the love of it, find his greatest pleasure in the knowledge that he knows his car from spark plugs to tires. He will know the meaning of the slightest sound which is distinct from the ordinary rhythm of the engine.

The garage will gradually accumulate the necessary tools as each job comes up until about the time that the second car is due to arrive, it will generally be found that Mr. Owner has his well-defined notions as to what kind of tools he wants and where he wants them kept. The character of the work turned out by the proprietor of the garage may be very closely determined before the work is completed by a casual inspection of the manner of keeping the tools. If the gasoline torch is found to be kicked into the farthest corner of the building because it did not happen to be needed in the last piece of work which was performed at the bench, an entirely accurate and correct idea of the manner in which the repair was carried out may be formed.

After the manner in which the garage is kept comes the despatch and neatness with which the actual work is done. It is assumed that the automobilist has some slight leaning toward things mechanical or he would have given up the attempt to be his own repairman a very short time after he first conceived the idea. Note the manner in which an experienced workman will go about making a repair. For one thing, there will be no lost motion. Lost motion is lost efficiency in any machine, whether the piece of mechanism be a man or an engine. There will be no misguided haste, but a continuous march toward the completion of the work.

A few customary repairs which may be easily carried out in

even the most meagerly equipped repair shop are here taken up and described by way of illustrating the correct method of procedure as compared with that in which the inexperienced man would go about the same work. A gasket is to be fitted, for example, between the cylinder block casting and the crankcase. The leakage between these two castings has been detected by a wheezing sound, and then on inspection the driver notices signs of oil having leaked through the joint. It is decided to replace the gasket, so the bolts which hold the cylinders in place are removed and the castings pried apart by means of a fine chisel lightly tapped upon with a mallet. This will disclose the crankcase after the cylinder castings have been lifted clear of the pistons and the same allowed, along with the connecting rods attached to them, to rest gently against the edge of the casting. The pistons are then removed from the connecting rods, leaving them in the position shown in Fig. 1. The method of removal will depend entirely on the manner in which the wrist pins are fitted. If it is easier to remove the caps of the connecting rods from the crank end, this may be done and the rods lifted out of the crankcase.

The old gasket is then thoroughly removed. This has to be done carefully by means of a scraper, as it will be found that the old one will adhere very closely to the metal surface and it will require the application of considerable force and a like amount of the proverbial elbow grease before this part of the work can be declared finished. The surface of the metal is then filed until it is entirely clean and bright when it is ready to receive the new gasket. If the cylinders are cast in pairs the



Fig. 2—Illustrating the method of filing the burr from clutch key

gasket is better when made in two pieces for a four-cylinder motor, as shown in the illustration. In other words, each block of cylinders should have a separate gasket. The new gasket will be bought accordingly in pieces, which are large enough to cover the parts to be fitted. It is first cut to the approximate size and allowed to rest upon the bolts which project as shown. The hammer is then called into service and a few light blows are dealt the material above each bolt until an impression has been made which will accurately determine the relative position of each. During this time the gasket is not allowed to shift its position. It is then removed and the holes for the bolts are cut in the positions shown by the marks which were impressed during the hammering. A slight allowance in size is made in the hole so that it will clear the bolt all around, thus taking up any inaccuracy there may be in centering.

After the holes for the bolts are cut in the gasket material it is slipped down over them until it fits flush against the surface of the metal to which it is to be fitted. It is at this point that the novice is often puzzled. Two holes have to be accurately cut, which will be of the same diameter as the cylinder and accurately centered in relation to the bolt holes. The amateur will often betray himself by starting to work with a rule and compasses. This, however, is not necessary; the correct and shortest method of procedure is to use the same method as that employed in cutting the bolt holes, that is, by means of the hammer. The gasket is tapped gently around the edge of the circle and around the outside where it is to be cut when finished; when removed it will be seen that the bounding edges of the gasket will be clearly defined and that the actual cutting will be easy.

In fitting keys the matter of experience again enters into the question to a large extent. Fig. 2 illustrates the act of removing the burr from a clutch key which was taken from the clutch as shown in Fig. 3. In removing irregularities from metal care should be taken that a bad fit does not result due to having filed away material in such a manner that the part no longer fits tightly. This is especially so in the case of a key held in the manner illustrated in Fig. 4. The other key shown above is fitted with two pins which keep it in the correct relative position. In fitting the key shown in Fig. 4, if it is desired to have the gears placed upon the shaft in a certain relative position, the shaft may be set in the vise as shown. The gears are then slipped over the shaft, the key inserted and hammered into place.

Besides the repairs mentioned there are numerous others



Fig. 4.—Method of driving key into keyway when it is desired to hold gears in correct relative position

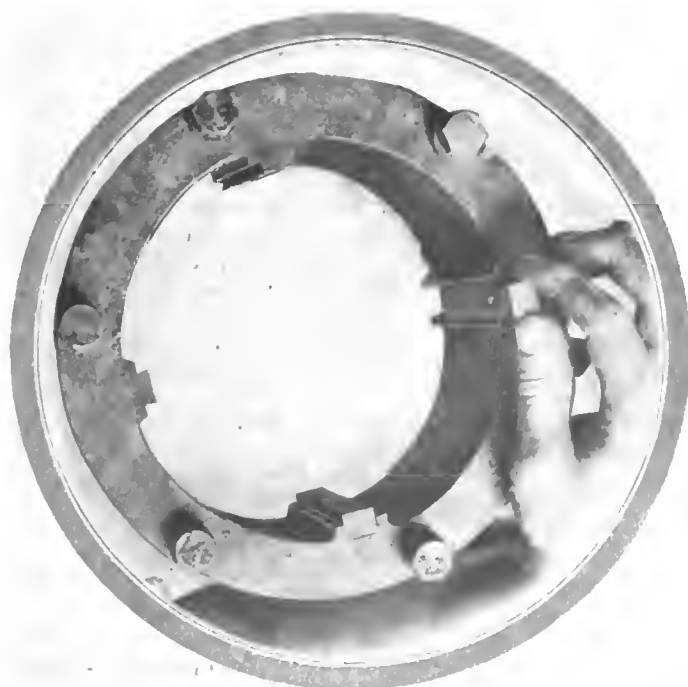

Fig. 3.—Showing position of key in clutch. This key is fastened by two pins

which will present themselves from time to time embracing every part of the motor, chassis and even the body of the car, until the owner will become so thoroughly acquainted with the various parts that, except in case of unlooked-for accidents, the matter of upkeep will resolve itself into a mere matter of schedule. Parts will need replacement from time to time on the best of cars, but with the care which a man who likes the work will give his own car the life of every part may be prolonged.

Whatever the work which is carried on in the garage the owner will find that the arrangements which were made in building it will always, so far as convenience goes, be a factor in the economical upkeep of the car. The finish on the body of the car is always more or less a matter of pride with the owner, no matter in what part of the country he may live. In the case of one who lives within the confines of the city or very close to its borders this upkeep of finish is a very important item. Mud may do a large amount of damage to a car, and here again the danger from this source may be practically eliminated by care and foresight. The only care really required is to take the mud off before it has time to harden. If the mud has once hardened and is then broken off, it will be found that the varnish has evidenced a penchant for adhering more strongly to the mud than to the body of the car. If a mild stream from a hose is turned on the car before the mud has hardened the deleterious effects will be entirely prevented and the life of the finish materially increased. A point to remember is that the temptation to turn the nozzle so that a hard stream will be projected against the delicate surface of the car must be overcome. It is true that the mud and dirt will come off much more quickly under the influence of this sort of stream, but the varnish will do the same, and hence care must be used.

Soft water is better than hard not alone for cleaning a car, but for the circulating system and the radiator. It is for this reason that many wise automobilists are fitting a rain-water trap to their garages, thus storing sufficient water for these purposes. The radiator should be washed weekly by allowing the engine to run for about three minutes with a soda solution in the water circulating system. Clear water is then run through and drained once and the system refilled.

# Letters Answered and Discussed

## Rubber Is Porous

EDITOR THE AUTOMOBILE:

[2,818]—I note in your issue of August 17 an editorial on the air pressure maintenance of tires. While I am not prejudiced in the matter, I am interested in the question of the maintenance of air pressure. While you have considerable to say against your correspondent's assertion as to the making of better tires you have absolutely nothing to say about a tire maintaining a constant pressure. Why not? I have had an experience similar to that of your correspondent. Where does the air go if the tubes are properly made, and why?

WILLIAM B. ELY.

Pittsfield, N. H.

## Wants Combination Tool

EDITOR THE AUTOMOBILE:

[2,819]—Perhaps you could tell me in an early issue whether at any time since last January a combination tool of six or seven uses has been noticed in THE AUTOMOBILE.

C. F. G.

See page 1416, issue of June 22, 1911, and page 241 of the issue of January 19, 1911.

## Not Enough Clearance

EDITOR THE AUTOMOBILE:

[2,820]—In order to increase the clearance of my car I wish to raise the springs a considerable distance above the live rear axle. I am not quite sure as to the manner of proceeding with the work, and I would esteem it a great favor if you would give me directions. I am a subscriber to your paper and follow the discussions with great interest.

OLD SUBSCRIBER.

Grand Rapids, Mich.

A block of fiber of the required thickness may be inserted as shown in Fig. 1. The block is placed upon the spring plate and the bolts passed through as shown. Care must be taken in this work that a good fit is made.

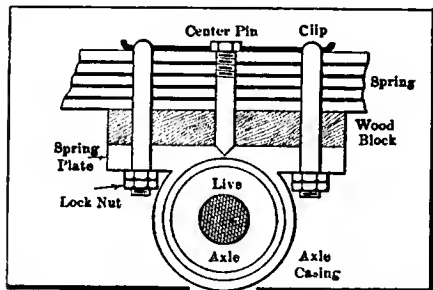

Fig. 1—Showing method of inserting block of wood to increase car's clearance

The Editor invites subscribers to communicate their automobile troubles and personal experiences, stating them clearly on one side of the paper. If the nature of the case permits, send a sketch, even if it be rough, in order to assist to a clearer understanding. Each communication will receive attention in the order of its receipt, if the writer's signature and address accompany it as an evidence of good faith. If the writer objects to the publication of his name, he may add a nom de plume.



## Engine Vibrates

EDITOR THE AUTOMOBILE:

[2,821]—As a reader of your magazine I take the liberty of asking your opinion on a problem which confronts me, my experience not having been sufficient to place the trouble.

My motor truck engine is a four-cylinder, 28-horsepower type. The cylinders are cast in pairs; three-bearing crankshaft timing gears in front; flywheel fairly heavy; cone clutch; double ignition;

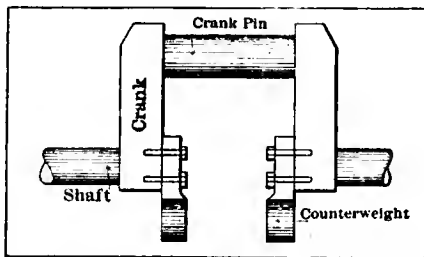

Fig. 2—Method of attaching counterweights in order to balance motor

double spark plugs in double caps on left (intake) side; exhaust on right side; extra heavy crankcase. The engine runs very fair at a medium speed, but when running, say, 30 miles per hour the vibration is terrific. Will you please give me your idea of the trouble?

LELAND A. KING.

New York City.

The engine is probably balanced well enough at low speeds, but when the piston speed increases the forces set up are not properly met. A plan which may be tried is to bolt counterweights on the crank as shown in Fig. 2. The weights should be carefully fitted in order to avoid lost motion, as the result would be a knock, very likely something worse. In fitting the weights take out each connecting rod with piston and rings and weigh them. If there is one which appears lighter than the rest favor that with the weights, which should all be the same shape and fitted on each crank. The gear ratios may not be suitable for the engine speed so that when the car is traveling at 30 miles per hour as you state the engine is really racing.

## Jerky Rim Motion

EDITOR THE AUTOMOBILE:

[2,822]—Being a subscriber to your paper, I take the liberty of asking a few questions.

(1) I find that when I am driving my car below 20 miles per hour the motor runs with a jerky motion. I have cleaned the air valve and have the right adjustment; have filed and set the magneto points, and also inspected the spark plugs, but still the trouble remains.

(2) The transmission, instead of running with a steady noise, sounds as if it were jerking, although the car does not jerk.

(3) What harm is likely to come from having excessive oil in the crankcase?

J. E. HORTON.

Hartford, Conn.

Questions 1 and 2 depend, probably, one upon the other. Lift the hood of the motor and open the compression cock of one cylinder at a time to determine whether they are all firing properly, or if the trouble is confined to one of them. If it is confined to one cylinder close the gap between the sparking points of the plug a trifle, or test if the insulation is leaky. If the trouble is common to all the cylinders there is probably a shortage of gas at low speeds, or the magneto has become demagnetized.

In the event of too much oil in the crankcase the motor will smoke and carbon will be deposited in the cylinder. The deposit of carbon leads to a variety of troubles, chief among which are overheating and pre-ignition.

## Automobile Improvements

EDITOR THE AUTOMOBILE:

[2,823]—I have a couple of improvements in automobiles, but don't know what to do to be sure of getting any profit out of them.

Would you advise me to patent them or to offer them to a maker of high-class cars?

I am an engineer and expert machinist.

N. W. K.

Aberdeen, Wash.

Patent first, then sell.

## Carbon in Cylinders

EDITOR THE AUTOMOBILE:

[2,824]—I would like to have some information in regard to soot in my cylinders. I purchased a new car five months ago and I now find that the cylinders are



heavily coated with soot. Any advice you can give me will be greatly appreciated.

SUBSCRIBER.

Lancaster, Pa.

Use kerosene or any reliable decarbonizer in removing the deposits. It would be well to let the kerosene remain in the cylinder over night in order to thoroughly soften the carbon before scraping it off. Care must be taken not to scratch the cylinders.

### Spark Plug Too Short

Editor THE AUTOMOBILE:

[2,825]—After reading your article on the position of spark plugs in a recent issue of THE AUTOMOBILE I took the cap and plug out of my car to see if it was right. I found that the plug did not go through by 3-16 of an inch. Would you kindly tell me what to do?

C. D. MCGEEHN.

New York City.

The difference in length can best be remedied by buying a longer plug, which will probably be too long. The difference in length on the longer plug may be taken up by means of washers above the spark plug cap.

### Insert a Ball Thrust

Editor THE AUTOMOBILE:

[2,826]—The thrust on my clutch continually overheats. It is of the plain type and will not remain cool in spite of ample lubrication. Would you kindly tell me what to do? Any advice which you may give me will be greatly appreciated.

CHARLES PETERS.

Wading River, N. Y.

The installation of a ball thrust would no doubt eliminate the trouble. A type of ball thrust is shown in Fig. 3, and to have it installed it would be necessary to send the car to a well-equipped shop.

### Clutch Jerks and Pounds

Editor THE AUTOMOBILE:

[2,827]—I am a subscriber to your magazine and would like to know what is wrong with my transmission or clutch. When running on high there is a jerking and pounding sound in the clutch or transmission. This sound is only when I am running slowly. By partly throwing my clutch out the noise stops to some extent. By giving the engine more power at the same time that I disengage the clutch the noise stops altogether. I have a cone clutch and it does not slip except on hill climbing.

J. R. B.

Paragould, Ark.

If the trouble is in the clutch and not in the ignition, as is very possibly the case, reface the cone with new leather.

The leather will in time rot if it has not been cared for in life. Test the alignment before going to the expense of a new leather.

### Wants to Brighten Brass

Editor THE AUTOMOBILE:

[2,828]—Being a constant reader and a subscriber to THE AUTOMOBILE I am taking the liberty to ask a question. Do you know of any preparation or acid which will restore tarnished brass to its natural color? If you would publish the information in an early issue of the paper it would be greatly appreciated.

LOUIS ULLMAN.

New York City.

So far as we know the best method to rejuvenate brass which is covered with verdigris is to use what is commonly known as bath brick and oil plentifully backed up by a supply of elbow grease. If the verdigris coating is not too thick a good brass polish may be used; this will, however, only be of use in cases where the dirt has not penetrated the surface to any great extent. If the parts to be polished are very delicate, they can best be taken care of by a buffing machine.

### Puncture-Proof Tire

Editor THE AUTOMOBILE:

[2,829]—I would like to get some information in regard to a device for rendering a tire absolutely puncture-proof. Has there ever been anything invented and put into practice which would render it impossible

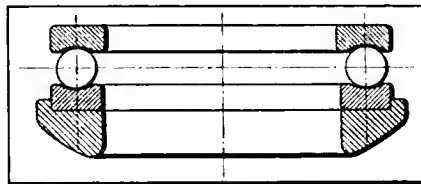

Fig. 3—Showing type of ball thrust to take up thrust on a clutch collar

to puncture the inner tube of a tire? What are some of the appliances that are placed between the inner tube and the outer casing? Have they proved to be a success? I would be very pleased if you would furnish the information.

S. POLITZY.

New Orleans, La.

There have been various devices placed upon the market from time to time which have been very successful in prolonging the life of the tire. As far as we know none have made puncture absolutely impossible.

### Piston Ring Sticks

Editor THE AUTOMOBILE:

[2,830]—Could you tell me how it would be possible to prevent the top piston ring from sticking, and how to release it without breaking it? The engine is a two-cycle air-cooled motor and is lubricated by putting the oil into the cylinder with the gasoline. I am using one quart of oil with five gallons of gasoline.

Any information you may give through your letter department will be appreciated.

Topsfield, Mass.

A. E. LAKE.

The reason the top piston ring sticks is probably because there is a thick deposit of carbon in the cylinder. Try using one pint of oil to six or seven gallons of gasoline in order to reduce the carbon deposit. There should be ample lubrication in this quantity of oil, as the proportion generally used is about one pint of oil to five gallons of gasoline.

There is no rough-and-ready method of releasing the ring from the piston. Remove the piston from the cylinder and allow the top ring to rest immersed in a bowl of kerosene over night. In the morning it will be found that the carbon deposit that has found its way behind the rings and perhaps along the sides of the grooves will have become soft and the piston ring can be removed in the ordinary manner. It stands to reason that the top ring will be more inclined to stick than the others as it is subjected to more heat than the others, which causes a quicker precipitation of carbon at this point.

The ring should be a good fit in the groove so that when it expands it will have just sufficient clearance to prevent it binding. If there is too much clearance the carbon easily finds its way behind and causes the trouble you complain about. Never touch the rings with a file. Use a surface plate on which a piece of fine emery cloth has been attached and, holding the ring in the hand flat, a slight rubbing will true the ring and remove all traces of carbon.

### Internal Brake Broken

Editor THE AUTOMOBILE:

[2,831]—Would you kindly tell me what to do to repair my brake? The internal brake on one of the wheels does not work and rattles continually, while the other is in good condition. The trouble happened suddenly when a sound as if something had snapped in the drum took place. Since then I have been unable to manipulate the brake.

E. F. G.

New Orleans, La.

The accompanying cut, Fig. 4, shows an assembly of an internal brake. The trouble with yours may be determined by an examination. It is very possible that the spring has slipped from the shoe.

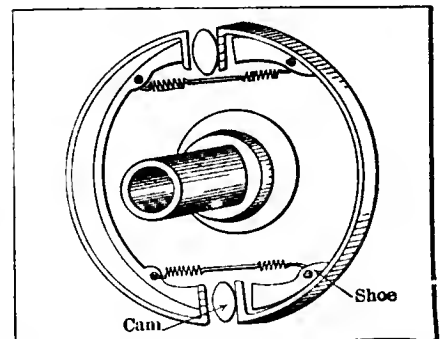

Fig. 4—Showing how the springs are generally held in an internal brake

# My 1912 Automobile

## Some Conceptions of What the Ideal Car Should Be

### Six-Cylinder Car for \$1,500

EDITOR THE AUTOMOBILE:

The following is a description of a car which I think would meet my ideal for a 1912 design:

The motor should be of 40-horsepower, silent-Knight type, six cylinders, cast in pairs, and a gear-driven eccentric shaft. The bore would be about 4 1-4 inches and the stroke 5 1-4 inches. The engine should have large bearings and plenty of hand holes for inspection purposes. Crankshaft should be of electro-manganese nickel steel.

The ignition should be double, with high-tension magneto and batteries, adjustable spark. Lubrication, positive force-feed and splash. Carburetion, heated with automatic double jet. The drive should consist of a cone clutch, four-speed selective sliding gear set with a worm-gear drive shaft. Cooling water should be circulated by means of a gear-driven centrifugal pump, the radiator being square tube, efficient and durable.

The front springs should be semi-elliptic, long and wide, with oil cups. The rear springs should be three-quarter elliptic, fitted with oil cups, and of good length and width. The wheel base should be from 116 to 120 inches in length. Tires, 34 x 4 or 36 x 4 1-3 inches. The rear axles floating, the front axles of I-beam section. The brakes should be on the hub and transmission, the first set connected with the clutch. The universal joints should be on drive and cone shafts. The differential and drive should be adjustable and accessible, with ball bearing change speed gears amidship, of best material. Tie rod should be in front of front axle. Car should have brake eveners, torsion rods, twelve spokes in wheels all around, distance rods and the frame should be strong and well braced and contracted back of front wheels.

The equipment should be complete, with control parts on top of steering wheel, tire pump, self-starter, gas tank, oil side and tail lamps, acetylene headlights, horn, complete tool and repair equipment, good cleanable muffler with cut-out, automatic speedometer, shock absorbers, roller and ball bearings and everything that will tend towards a state of being dustproof and silent. All parts should be interchangeable.

The weight of the car should not be above 2,400 pounds when equipped, and the speed ought to be up to sixty miles per hour. The gear and brake handles must be in easy reach, and the steering so arranged that it is possible to take up lost

motion. A price list of parts should accompany the car, and prompt repair service should be made a feature. The automobile should be made by a concern who intends to stay in the business. A neat appearance should be made an object, the car being clean-cut and not loaded down with junk and dust catchers. I believe in a four-passenger torpedo body, with a place to carry all necessities, as well as a spare tire. Price, \$1,500 to \$2,000.

N. T. G., Md.

Turbotsville, Pa.

### A Rational Buyer

EDITOR THE AUTOMOBILE:

After several years of experience with cars of different makes ranging from 3 1-2 horsepower to nominally 100 horsepower, the ideal car of my choice would be one of approximately 25 horsepower. I consider that it is possible with a car of this size to do anything that a car of 50 horsepower or more can accomplish, and, what is more, the reduction in weight would materially assist in the keeping down of tire expense. The motor should be a bloc motor either of the best design of poppet valve or with some accepted valveless design. Perhaps I might have a slight inclination to the latter, as it is something new, and taking care of my car as I would of a thoroughbred horse, it would have all the attention lavished upon it that I understand this type of motor requires.

The bore should not be more than 4 inches with a stroke of from 4 1-2 to 5 inches. The ignition system I prefer is a plain straight high-tension magneto in which the armature and pole pieces are capable of being rotated at the same time so as to give maximum power at all engine speeds. I would like the crankshaft to have five main bearings and instead of drilling it hollow for the entire lubrication I would feed a pipe to each cap of the bearings at its bottom side so that oil could be forced into the bearings under a pressure of, say, 5 pounds per square inch. The oil pump should be of the positive plunger type driven by an eccentric strap off the half-time shaft, but so situated that it would be readily removable. I would do away entirely with under-trays and have the sides of the crankcase cast with integral webs that would answer the same purpose. The clutch would be of the conventional cone type with the male boss made from pressed steel slotted at various points so that the leather would not be

compelled to fit tight against the entire face of the flywheel. The spring operating the clutch should be of the enclosed type with simple adjustment and ball thrust so that there would not be any thrust on the crankshaft while the motor was running with the clutch in.

Three speeds and reverse are sufficient for this size of car if properly designed, but I should prefer another gear for the fourth with an over-direct drive so that the direct drive would be about 3 1-2 or 4 to 1 on third speed. The final drive would be by full-floating live rear axle, the propeller shaft enclosed in a tubular casing terminating at the forward end in a forked joint. I should prefer worm drive.

As regards suspension it would depend upon the weight of the chassis, which in my opinion should not exceed 1,800 pounds. The dimensions of the chassis would have some bearing on the length of wheelbase. The chassis should be 80 inches behind the dash to the rear end of the frame and the radiator should be set 2 or 3 inches behind the front axle. With a monobloc motor the hood would not take up a lot of room so that the wheelbase would not exceed 110 inches. The car should be fitted with worm and block steering and be capable of turning in a 32-foot street. The gasoline tank would be placed in the cowl of the dash so as to leave the compartment under the driver's seat free for tools, and access thereto would be had by three doors, one at the driver's heels and one on either side of the body. The running boards would be entirely free from all encumbrances and the tires would be set in a sunken well behind the rear seats. The body would be a two-seated coupé with a leather top so that the passengers would be sitting amidships. I cannot see any advantage in left-hand control, so would have the control on the right side. Some people like to have the dash free from all fittings, but I would like to use it for as many as I could conveniently get there—not useless ornaments, but fittings that would tell how the oil and water were circulating, cylinder testing cutouts, etc., in short what the market afforded that would help in cutting down costs in upkeep. This may sound foolish, but it is better to spend a few dollars on a fitting that will positively save in gasoline consumption than to put money in the pockets of the oil company.

Some people want a car that will run without trouble, and so do I; but instead of kicking at the bills I am prepared to try to reduce them. One cannot expect a

manufacturer to tune a car up to the pitch that it will require no further work on the part of the owner. The running in of 500 to 1,000 miles makes all the difference, and to take advantage of the bettered condition it is necessary to do something oneself.

The price of the car with the necessary material for longevity would be about \$1,700 without extras, and if such a car were turned out and the advantages were placed before a discriminating public there is no reason why it should not meet with the same success as the cheap imitation of the same power. M. P. H. New York City.

Sleeve-Valve Motor

Editor THE AUTOMOBILE:

I am sending herewith a description of a car which, if it could be made for the specified sum, ought to set the world on fire. I do not know the cost of manufacturing Knight motors or the royalty required upon them, but I am sure that this car would prove a world-beater.

The engine should be of the Silent-Knight type having upward of 28 horsepower, a bore of 4 1-4 inches and a stroke of 5 1-4 inches. It should be equipped with dual ignition and lubricated by the mechanical force-feed system. The number of the cylinders should be four and they should be cast in pairs.

The car should be shaft-driven, with a cone clutch with cork inserts and a selective type gearset located in the center of the chassis.

The suspension should be on semi-elliptic springs forward and three-quarter-elliptic springs rear.

The wheels should be arranged so as to give an 118-inch wheelbase with 36 x 4 1-2-inch tires of the best quick-detachable demountable type.

The axles should be equipped with roller bearings, both front and rear.

The control should consist of clutch and brake pedals, emergency pedal and accelerator pedal.

The equipment of this car ought to be perfect and entirely complete, the electric lighting being by means of the Gray & Davis dynamo or the entire electric system by means of the Delco Company's product, including self-starter and all the other refinements accompanying the system. A good speedometer-clock combination must accompany the car and the switch equipped with a Yale lock. The rear springs should be fitted with shock absorbers to ease the motion of the car, and for the comfort of the passengers a foot rail should be placed in the tonneau as well as a robe rail. A wind shield and top should be provided. Adequate license holders must, of course, be in place.

The mechanical fittings throughout should be of the best, all oiling places convenient and grease cups large. The gasoline tank

should be equipped with a gauge as well as a lock. The tool box, located on the running board, should be provided with a full set of tools, including jack, etc.

This car ought to weigh when completed about 3,200 pounds, the body being of the five-passenger touring style, and should sell for \$2,000 to \$2,500. K. P. HEINTZ. Cumberland, Md.

Comfort the Main Idea

Editor THE AUTOMOBILE:

I have read with much interest your letters on the 1912 car, and it seems to me that many of your readers are wasting space on items of car construction that are not of real importance to the car owner. Two inches longer or shorter in the matter of wheelbase do not make any difference in the running of a car; one magneto is often as good as another and troubles with that adjunct are not very numerous. The big question that does concern every car owner is the matter of arrangements for carrying the tools and extra baggage. This is a department in which every 1912 automobile can be improved.

In carrying tools it is common to carry the tire repair outfit under the rear seat. This is very awkward. Supposing a valve leaks and the tire does flat, it is necessary to get the jack and tire pump from under the back seat. There may be three women in the tonneau and it may be raining.

The entire comfort of all three has to be upset. They have to get out of the car, because the rear seat cushion is so big and awkward that one cannot possibly get at the jack and pump until the cushion is removed. It is not very pleasant to ask women to get out of a car onto a muddy road on a cold, wet day. But once the women are out the task has but just begun. The jack and tire pump are generally the heaviest tools in the compartment and are usually placed at the bottom of it. In order to get them one must first take out some inner tubes, perhaps a side curtain or two (if they are not already in use) and there may be some other tools to remove before the jack can be got at. The net result is that everything, including the cquanimity of the party, is upset simply in order to get a jack and a tire pump.

There is a remedy: Tire tools, including jack and pump, should be carried in the same place, and it should be in a convenient position. If there is no room on the running board a compartment should be provided under the chassis midway of the car on the left side. This may be just in the rear of the gearbox. Access can be had through the left tonneau door by means of a hinged door in the floor immediately inside of the tonneau door. Raising this door will not interfere with the tonneau passengers, and it is as convenient a place as can be found. F. J.

Elgin, Ill.

THE AVERAGE CAR

The invitation to our subscribers to describe their ideal 1912 car has struck a popular chord. The responses show a wide appreciation of the salient points of car design and a knowledge of the points which tend to reliability and comfort. THE AUTOMOBILE hereby continues the invitation to its readers to mail in their conception of the features which should be embodied in next year's car. The information given should include such points as:

Horsepower	Stroke	Drive	Front axle
Cylinder type	Ignition	Springs	Control parts
No. of cylinders	Lubrication	Wheelbase	Body features
Cylinders, how cast	Clutch	Tire sizes	Equipment
Bore	Gearset	Rear Axle	Price

In addition to giving these details the reasons for your points of selection should be stated concisely and clearly.

As a benefit in the matter of comparison some details of the average cars for 1911 are given below.

Each communication must be legibly written on one side of the paper only; it must be properly signed with the writer's full name and address, and if the writer does not wish his own name to appear in print he may request the use of any nom de plume.

Any reader desiring to make line drawings, showing details of his ideas of his car or some of its parts, is requested to do so.

Editor THE AUTOMOBILE.

DETAILS OF AVERAGE 1911 CARS WHICH WILL ENABLE READERS TO MAKE COMPARISONS IN DISCUSSING 1912 MODELS

	\$1,000 and there- abouts	\$1,500 and there- abouts	\$2,500 and there- abouts	\$4,000 and there- abouts
Horsepower	20.5	29.525	35	43.66
Bore	3.98 inches	4.19 inches	4.40 inches	4.875 inches
Stroke	4.12 inches	4.64 inches	4.98 inches	5.39 inches
Wheelbase	100 inches	114 inches	119 inches	124 inches
Front tires	31.4 x 3.3	33.1 x 3.8	35 x 4	35.7 x 4.27
Rear tires	31.4 x 3.3	33.1 x 3.8	35 x 4.1	36.7 x 4.55
Number of cylinders	Four	Four	Four	Four
Cylinder type	L-Head	L-Head	L-Head	T-Head
Cylinders cast	Pairs	Pairs	Pairs	Pairs
Ignition	Dual	Dual	Dual	Dual
Clutch	Disc	Multiple disc	Cone	Multiple disc

# Little Bits of Motor Wisdom

## Pertinent Pointers for Repairman and Driver

*A series of short stories that will tend to keep the automobilist in touch with matters mechanical and otherwise—quick soldering jobs, the use of the dowel pin, necessity for methodical inspection, aid to selection of proper-size tires, how to calculate clearance in per cent., amount of vapor in air, etc.*

**S**MALL SOLDERING JOBS—It very often occurs that the automobilist will reach the determination to do a small soldering job rather than send it out and suffer the delay which such a proceeding generally entails. With very few exceptions more disappointments have resulted from attempted soldering, all because a few trifling but necessary preliminaries were not observed.

The first and perhaps the most important precaution to be observed is that the parts to be soldered are absolutely clean. Not apparently clean, as that will never suffice, but thoroughly, mechanically and chemically clean. Every slightest particle of grease, dirt or rust, as well as any other foreign matter, should not only be carefully removed but kept away by means of an application of what is known as flux.

After the primary or mechanical cleaning has been accomplished by means of a scraper, file or alkali solution, or perhaps by all three, apply the flux immediately so that the oxide film cannot regain a hold on the metal. If a liquid flux is used the metal to be soldered should be first heated and then the liquid applied. If the flux employed is borax or resin in solution it may be applied to the metal before it is heated.

The parts to be soldered are then heated until they are of sufficient temperature to keep the solder at melting point for the length of time required to finish the work if the parts are fairly small; or in any case until a fair quantity of work is done. The correct temperature varies with the different materials treated and may only be well learned by actual experience or by watching the work of others. Very good

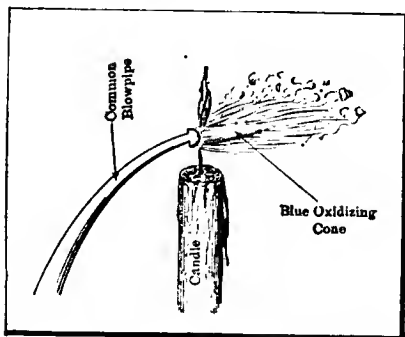

Fig. 1—Method of using ordinary blowpipe with candle flame for small soldering jobs

results will, as a rule, be obtained even by the novice if it is remembered that the metal should not be too hot. If the work is carried on at too high a temperature the oxides of the metal will form on the surface in spite of the flux and the result will be disastrous as far as a good soldering job is concerned. Sufficient temperature for the average work may be obtained with the ordinary blowpipe and candle flame shown in Fig. 1. In soldering large pieces the metal surrounding the part to be soldered will carry the heat away from the joint too rapidly owing to the high conductivity of metal; hence in a case of this nature it is necessary to use a kerosene or gasoline torch.

The solder itself performs the office of a metallic cement and is generally composed of tin, lead or a combination of both. It is placed upon the joint and smoothed down by means of the soldering iron or bit, which is of different materials, generally having a copper head. In soldering aluminum a pure nickel soldering iron should be used to avoid discoloration of the metal. Before starting to solder the bit is tinned with the solder to be used, or with pure tin. This tinning process lends much to the certainty of a good result and is carried on as follows: The bit is first scraped with a piece of emery or a file until all particles of the scale with which it will generally be found to be covered have been removed. It is then plunged into zinc chloride and heated to the working temperature, which must be below redness. A stick of tin is held against the bit and will be found to adhere to it if it is not too hot.

When determining whether a certain piece of work should be soldered or welded it must be remembered that the solder is not very strong so far as tensile strength is concerned and that while furnishing a very cheap and good connection a soldered joint is not to be depended upon where any great strains are to be endured.

**CYLINDERS REQUIRE REBORING**—The metal in the cylinder walls is too soft to stand continuous service. Designers desiring, in the first place, to have the weight efficiency as high as possible take advantage of the fact that white metal is dense, hard and strong. Gray iron, on the other hand, is

soft and is likely to be of varying texture. White metal in a cylinder is induced by so regulating the charge that it will take on the property technically known as "chill." This "chill" is not to a great depth in good cylinder metal, so that in order to preserve the white metal surface the finish must be restricted. It will be remembered that all finished metal is machined off, and what is wanted in completed cylinders is just enough finish to permit of making a smooth bore without cutting through the white metal coating into the gray iron texture.

**USE OF DOWEL PIN**—Where two surface plates are to be placed one upon the other

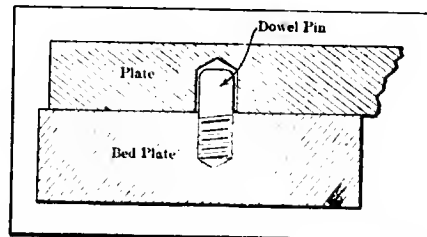

Fig. 2—Illustrating a dowel pin used to secure proper relative positions of two flat plates

and have always the same relative positions a pin known as a dowel is employed. The usual form of this pin is shown in Fig. 2, which shows a section through the two surface plates and the manner of fitting the pin. The bed plate is tapped and the pin screwed in for about one-half its length. The other plate is then drilled in the proper position so that there is no possibility of misplacing the plate.

In drilling the plate which fits over the pin care must be taken that the hole is not too large, as otherwise it would be possible for the plate to slip in any direction, and this would defeat the purpose of the pin. One pin does not entirely fix the relative positions of the two plates. It takes two to obviate any possibility of rotation. One pin would fix the position if there were guide plates on either side of the plates to prevent rotation.

**DOGS MUCH USED**—One of the useful appliances in the way of securing cover plates, manifolds, etc., in their proper positions is the dog. The form that this takes in automobile practice is shown in Fig. 3.

There are two faces which bear against the manifold flange or against the part to be held in place. The bolt passes through the center of the arm and into a tapped hole in the part to which the manifold is to be connected. There are endless variations to the shape of the dog, even at times taking the form of a flat plate, but the purpose fulfilled is the same, namely, that of holding various pieces of metal in place, which it would be unsuitable to hold by means of separate bolts. Since one bolt is performing the duty of several, it should be of sufficient strength to sustain the strains to which it will be subjected in this case; therefore the diameter should be relatively large.

From an inspection of the illustration it is evident that the dog will be subjected to a large bending stress, and hence will have to be of strength in this direction where any strain is to be placed upon the bolt. A permanent set in the dog would result in a leaky joint since the faces would not bear equally against the flange.

**METHODICAL INSPECTION NECESSARY—**

Even the latest convert to the world of motoring recognizes the necessity of an occasional tour of inspection about the various parts of the car. Inspection in itself, while a *sine qua non*, is not sufficient to fully determine the fitness of the

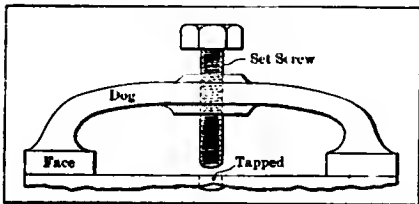

Fig. 3—Type of dog often used in motor construction to hold manifolds in place

car on all occasions. The motorist should observe a certain routine which will suggest itself by experience or preference, rather than make a random inspection which, while it may accomplish the desired end ninety-nine times out of a hundred, will be sure to result in the overlooking of some important detail sooner or later.

A good method to pursue, for the man who owns his own garage and enjoys the work which must be done about the car, is to post a schedule on the wall of the garage. Oiling charts are generally furnished by the makers of the car with directions as to how often each part is to be lubricated and what sort of grease or oil to use. Follow this advice closely and remember that a new car requires more oil than an old one. A wiring diagram is also a valuable adjunct, and will aid the motorist to a large extent in his occasional survey of the car ignition system.

A list of parts which are apt to become clogged may be also made up and will consist of the gasoline piping, water jacketing, radiator, carbureter needle valve, etc. The weekly washing-out of the radiator with

soda solution will obviate the dangers of scale. Leaks, knocks and squeaks must be sought for and remedied as soon as they appear, always remembering that where a repair is of a temporary nature it should not be allowed to remain long without being replaced by a permanent one. After some experience has been gained the habit of methodical inspection will be deeply ingrained and the rapidity of the work will be markedly increased.

**TO SELECT THE RIGHT SIZE OF TIRE—**The first point to take into consideration is the weight of the car, and this is a matter that seldom occurs to the owner. By weight is meant the complete weight of the car loaded with full equipment of passengers, tools, luggage and full tanks. Even before the question of sizes of tires is considered this should be found out and a certain margin for safety allowed in case additional weight is carried from time to time.

The way to ascertain the weight is to place the front wheels on the scale first and the rear wheels afterward to find what weight is carried on each axle. This amount halved will give the proportion of the total weight each wheel has to carry.

The following table shows the weight a given size tire is made to carry and the pressure to which it should be inflated:

Diameter of tire in inches	Max. allowable weight on wheels	Air pressure in pounds per square inch
2 1-2	225 pounds	50
3	350 "	60
3 1-2	600 "	70
4	750 "	80
4 1-2	1,000 "	90
5	1,000 "	90 to 100
5 1-2	1,200 "	100 to 105

If the flexure of one tire is greater than another for the same pressure it is as well to reduce the pressure of the highest to correspond with the other to equalize the flexures. There is danger of extra tire depreciation if one tire is blown up stiffer than another.

**CUSHIONING THE BODY.**—In order to take up the shocks which will be transmitted through the office of the chassis to the body of the car, a rubber insert is often placed in such a way that there is no direct contact between the two. A manner of installing the rubber cushion is illustrated in Fig. 4. The angle iron bracket which takes all the weight is equipped with a box-like cover which contains the rubber insert. The box is continued to a sufficient height to hold the body in position besides holding the rubber. This box is shown to be cut away in the illustration in order to indicate the relative positions of the parts.

**WEIGHT OF VAPOR AIR WILL HOLD AT 32 DEGREES FAHRENHEIT—**Primarily the weight of any vapor that air will hold will depend upon the temperature to which it is raised, and the higher the temperature the greater

will be the volume, and the lower the weight of the air. A state of saturation will follow for each temperature, and while the volume of air will increase with increasing temperature, thus decreasing weight, so that the capacity of the air for vapor will increase. The weight of vapor per hundred pounds of air, at different temperatures, may be determined in the manner as follows:

$$W = \frac{62.3 \times E}{29.92 - E} \times \frac{29.92}{p}$$

When,

E=elastic force of the vapor at the given temperature, in inches of mercury.

p=absolute pressure in inches of mercury, = 29.92 for the pressure of the atmosphere as ordinarily taken.

w=weight, in pounds, of vapor, for complete saturation, at the given temperature, at which elastic force is determined.

The vapor-carrying ability of the air is of the utmost importance in connection with carburetion, since, if the air is not in a state to hold vapor of gasoline to the desired extent, the results will fall off accordingly. The accompanying table will serve to render comparison potent, as well as to clearly indicate the reasons why atmospheric conditions influence the performance of cars in practice.

Capacity of Atmospheric Air for Vapor at Different Temperatures.

Temperature in degrees Fahrenheit	Pounds per cu. ft. dry air	Pounds of vapor in one pound of air	Weight in pounds cu. ft. saturated air	Weight in pounds cu. ft. vapor in air	A/V
32	0.0807	0.00379	0.0802	0.000304	263.7
42	0.0791	0.00561	0.0784	0.000440	178.18
52	0.0776	0.00819	0.0766	0.000627	122.
62	0.0761	0.01179	0.0747	0.000881	85.
72	0.0747	0.01680	0.0727	0.001221	59.5
82	0.0733	0.02361	0.0706	0.001667	42.3
92	0.0720	0.03289	0.0684	0.002250	30.3
102	0.0707	0.04547	0.0659	0.002997	22.

The ratio A to V clearly indicates the rate at which the air changes in its ability to sustain a vapor, and also the effect produced on the weight of vapor per cubic foot of the air. A close inspection of the table given above will also explain the great advantages of using preheated air for vaporizing the gasoline that is to be burned in the motor, as this air is able of absorbing a comparatively high amount of fuel.

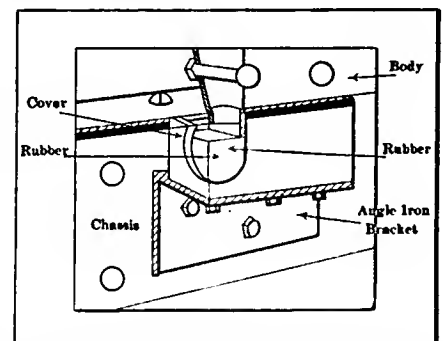

Fig. 4—How rubber insert is used between body and chassis to secure easy riding qualities



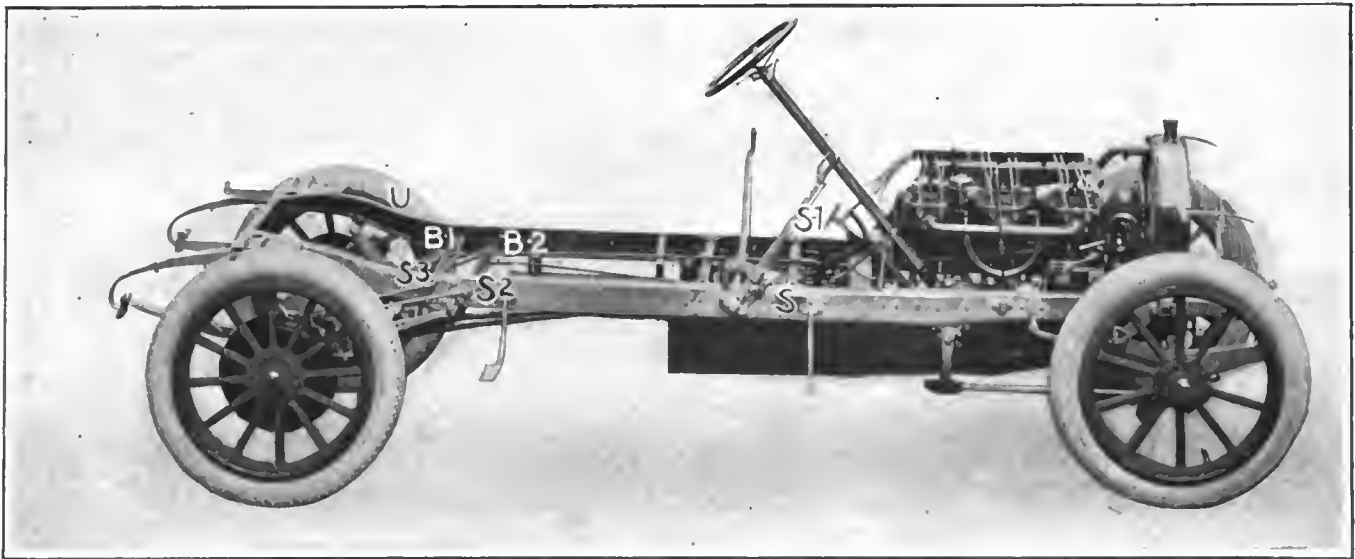

Fig. 1—General appearance of the Pierce-Arrow six-cylinder chassis

## Pierce-Arrow 1912 Models

### Few Material Changes in the Smaller Cars

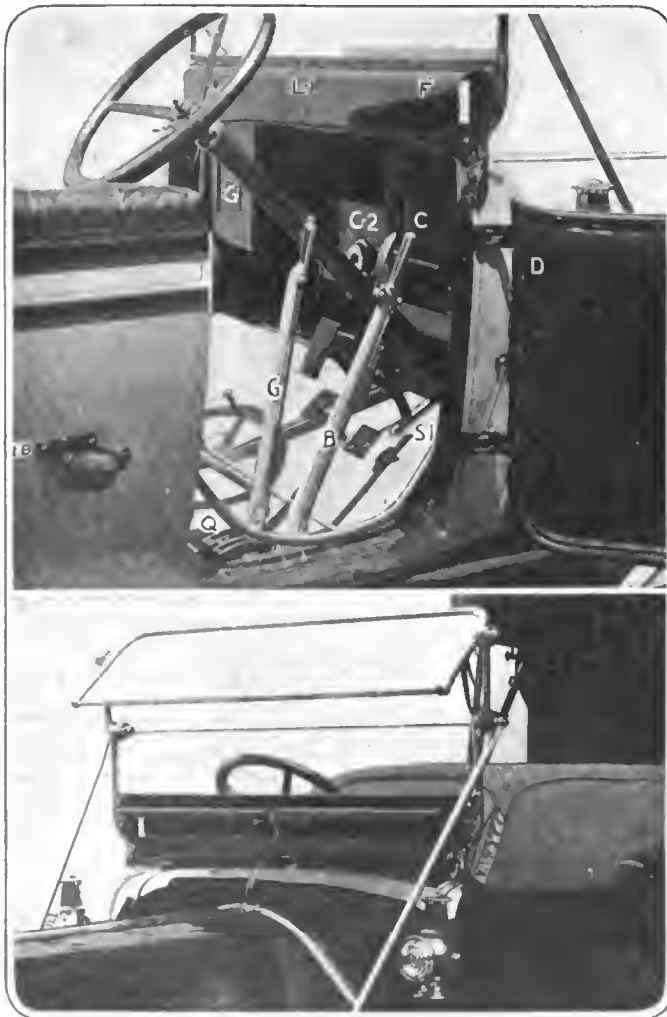

Fig. 2—All doors are made to open, showing how the levers are placed entirely within the body. The new ventilator can also be seen  
Fig. 3—Showing the new type of windshield, the open flaps of the ventilator and the neat side lamps

TO place concisely before purchasers of cars the offerings of the Pierce-Arrow Motor Car Company of Buffalo for the ensuing season it is here proposed to deal with the various models separately in order to avoid confusion. But as a general introduction it may be mentioned that the new models are not characterized by any radical changes. The principal change of note is found in the largest model manufactured by this concern.

For the sake of clearness it is necessary to refer to the dimensions of last season's models to enable the reader to draw a comparison with the new model. Much discussion has taken place in technical circles relative to the rating of gasoline motors in the endeavor to come to some tangible solution of the present puzzling situation. The tendency of the last year or two among designers seems to point to a penchant for the long-stroke motor, and an instance of this is found in the new "66" Pierce-Arrow. The past season's model had a bore of 5 1-4 inches with a piston travel of 5 1-2 inches. According to the accepted rating adopted some years ago this would give a horsepower rating of 66, but in the new motor the bore has been decreased by 1-4 inch to 5 inches and the stroke increased by 1 1-2 inches to 7 inches, and according to the formula the motor would appear to be less powerful. This is due to the fact that the piston travel is taken at 1,000 feet per minute irrespective of stroke. A more rational manner of viewing the situation is by considering the comparative piston displacement, which is in reality the main factor. The piston displacement of the new model is 770.67 cu. ins., while the displacement of the model of last year was 714.36, which shows an increase of 56.3 cu. ins. for the 1912 motor.

The piston travel per minute being presupposed, according to the formula, to be 1,000 feet per minute, it is interesting to see how this compares with the motors under consideration. The 1911 motor required 1,143 revolutions per minute to attain the above-mentioned piston travel, but in contrast to this the new long-stroke motor with its 7-inch stroke requires but 857 revolutions per minute to accomplish the same piston travel. Block tests of the new motor have been carefully carried out and show that the new motor has an advantage of 15 horsepower over last year's model at 1,000 revolutions per minute.

The general appearance of the different models of Pierce-Arrow cars as far as it relates to the chassis details can be seen by referring to Fig. 1, which shows the right side of the chassis.



Fig. 4—48-horsepower seven-passenger touring car with fore-door flush-sided body

The rear end of the chassis is given a slight up-sweep to take care of the three-quarter elliptic suspension, and the method of controlling the brakes is also shown.

The rods from the pedal or side lever pull upon the cross bars B1 and B2, which are attached to the side rods that operate the brakes by means of universal-jointed swivels, S2 and S3. As the brakes may not both have the same adjustment the slots in the chassis are cut sufficiently long to allow the cross bars to pull more on one side than the other if necessary to permit of equal braking effect on both of the rear wheels. With the present tendency for flush-sided bodies, which necessitates a wider framework for the upper structure, the side runners of the body rest upon the brackets S and S1 shown in Fig. 1. The method of shackling the front springs can be seen as well as the method of supporting the cross-arm of the steering after leaving the box beneath the chassis frame.

Figs. 2 and 3 show two interesting innovations to this line. All doors are made to open in the manner shown in Fig. 2, and the new method of placing the levers B and G entirely inside the body is also depicted. The body is wider both front and rear, thereby giving greater comfort to the occupants of the tonneau.

The dash is formed in the shape of a cowl, the inside of which is fitted with closets provided with locks to facilitate the storage of such parts as may be most often wanted, such as goggles, maps and the like. The spark coil for the supplementary ignition is placed between these two boxes in the manner shown and a new switch is provided thereon with a connection that gives both battery and magneto ignition at the same time. Alongside the coil is a lighting attachment which permits the gas headlights being turned on from the seat, the spark being furnished automatically.

A new glass front with a rain vision fold has been adopted and the new front and fenders are dished to give greater rigidity and are made of steel, the bolts and rivets not being in evidence. In order to maintain perfect ventilation without causing a draft to the forward compartment of the car a ventilator unique in design has been incorporated in all the open models. Fig. 2 shows the rear view of the windshield and it will be noticed that the lower part is fitted with a metal flap F in the center of which is a lever L1. This lever controls two windows which are plainly shown in Fig. 3. The air that passes through these windows, when open, is caused to descend to the lower part of the front compartment, owing to the shape of the flap inside the body, which has the effect of expelling the heated air that rises through the floorboards. Another new point in next year's models may be seen by referring to Fig. 3, which shows the new side lamps that have been adopted.

The general lines of the three models of Pierce-Arrow cars

are almost identical as far as appearance goes, the variations in dimensions constituting the main differences.

The 48-horsepower, seven-passenger touring car can be seen by referring to Fig. 4, which shows very clean design. Inside guards are fitted to the mudguards both front and rear, and the valances fitted between the chassis and the running boards add

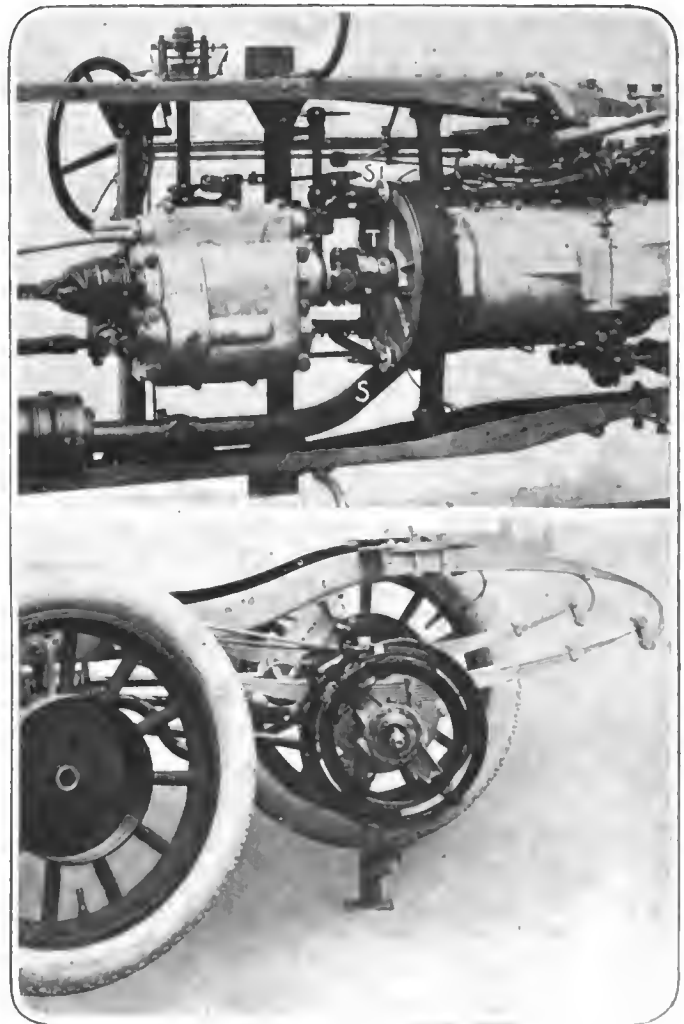

Fig. 5—View of the Pierce-Arrow chassis from below, showing the new clutch stops and the brackets on which the body rests

Fig. 6—Suspension of the rear of the chassis which has been slightly modified, showing the braking mechanism

materially to the cleanliness of the general appearance. Exterior door handles have been done away with, small levers set in the top of each door taking their place.

**The 36-Horsepower Model**

The engine will be the same size as last year, the bore being 4 inches and the stroke 5 1-8 inches. Referring to the illustration of the motor shown in Fig. 9 the general arrangements of the left side of the motor will be seen. The motor is supported by the cross members C and C1, which are attached to the crank chamber by long through bolts, the upper lips of the supports resting upon the side members. The cylinders are cast in pairs with T-shaped heads and the internal details of the motor are shown in Figs. 8 and 12.

The train of half-time gears is placed in front of the motor and enclosed in an aluminum housing. The shaft that drives the pump carries at its forward extremity immediately after leaving the casing a gear which is used to drive the air pump P shown in Fig. 9. The gears G1 and G2 are caused to mesh by the use of a small lever not shown in the illustration. A sectional view of the air pump is shown in Fig. 8. The water flows to the intake pipe of the centrifugal pump P1 and is forced to the bases of the cylinders at the points W1, W2, W3, a universal joint U of the Oldham type being inter-

posed in the driving shaft to take care of alignment and permit of easy assemblage. The rear end of the pump shaft is extended through the casing of the pump and is fitted with a tongue joint C2 so that an electric generator may be driven direct where such and outfit is desired. The crankcase has four bosses, B1, B2, B3 and B4, already provided with bolts so that the generator can be bolted on. The cylinders are on this and both of the other models will be tapped for S. A. E. standard spark plugs, 7-8 inch in diameter and 18 threads.

The internal and external brakes, the design of which can be seen by referring to Figs. 6 and 7, are much larger, the brake drums being 14 inches in diameter and 3 inches wide. The rear springs have less arch, the upper portion of the half springs being clipped on the under side of the gusset plate instead of on the top. The springs, being almost flat, constrain the rear axle to move in an almost vertical path, thereby eliminating the action of the brakes going on when the car bounces or when there is a difference of position owing to the car being loaded or unloaded.

Fig. 5 discloses a new feature on Pierce-Arrow cars for the coming season. In order to facilitate the changing of the gears two friction pads are fitted at S and S1 which form clutch stops checking the rotation of the male member of the cone clutch when this is withheld. A ball thrust collar T is used on all the new models and the transmission cover has had to be altered to accommodate the gear shift, which has been placed 2 inches inboard. The details of the gear shift are shown in Fig. 11, in which an interlocking device is seen preventing the engagement of the clutch with the gears half in or with two sets of gears in mesh at the same time. The shafts have been considerably

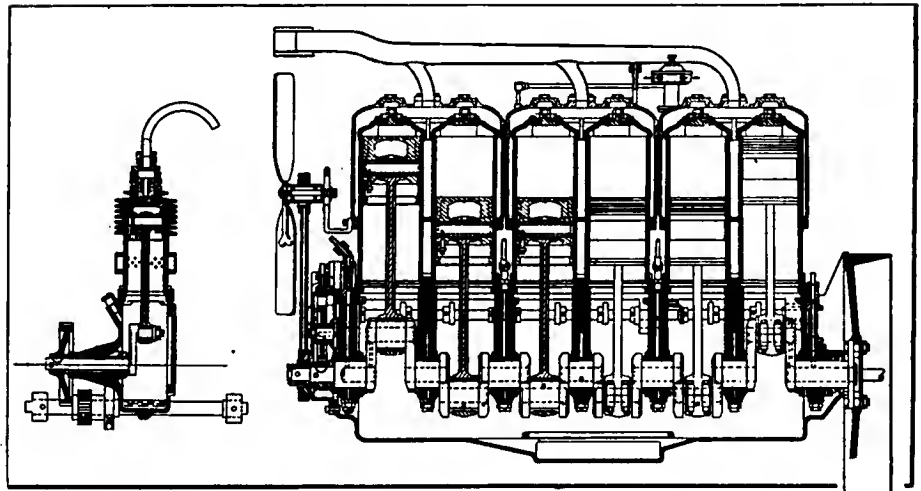

Fig. 8—Lateral cross-section of a Pierce-Arrow motor with seven-bearing crankshaft and the section of the air pump for tire inflation

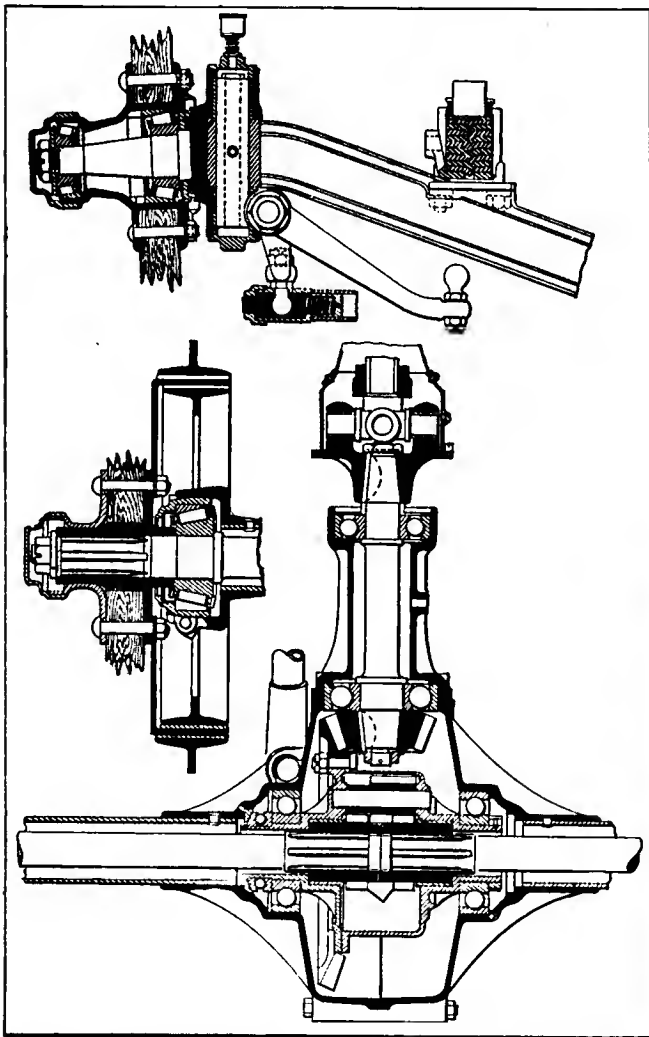

Fig. 7—Front and rear axle of the Pierce-Arrow, showing the details of the general assembly of the differential and front knuckles

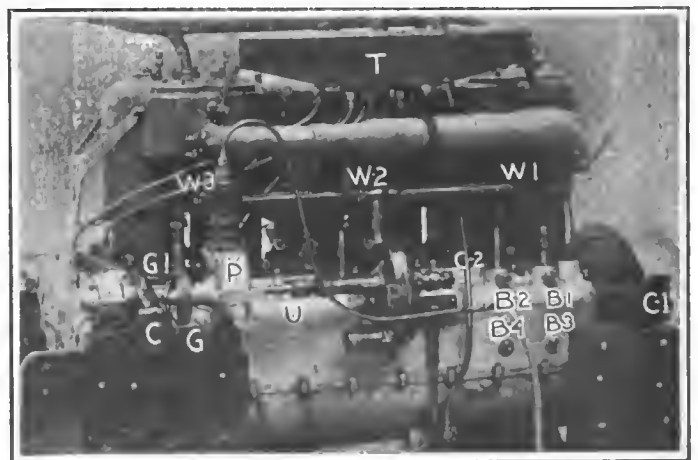

Fig. 9—View of the left side of the Pierce-Arrow motor, showing the air pump, water and oil pumps, lubricating oil tank and leads

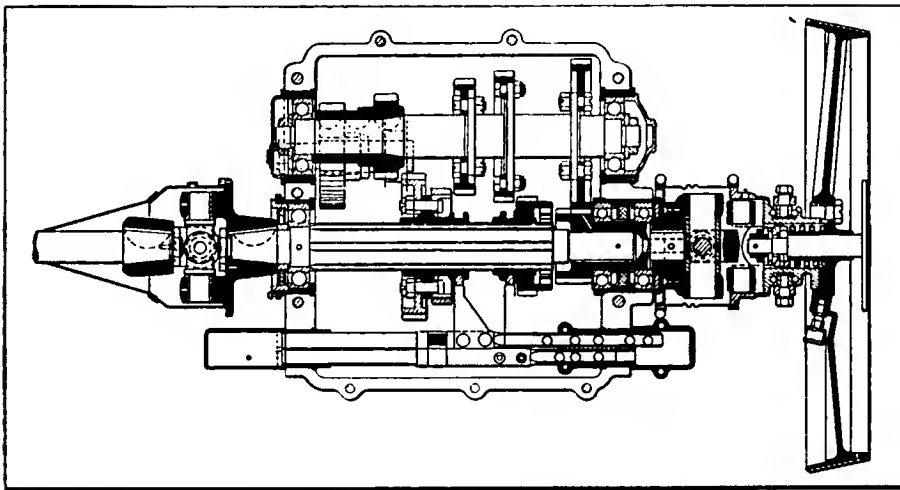

Fig. 10—Sectional view of the clutch and transmission assembly showing the method of assembling the parts

strengthened and the primary shafts on which the gears slide are milled with six feathers or splines instead of four as heretofore. The rear springs are 4 inches longer and have less arch. A gasoline gauge is fitted on the dash which shows at a glance the amount of gasoline in the 28-gallon tank.

**The 48-Horsepower Model**

The size of the 48-horsepower motor remains the same as last year, viz., 4 1-2-inch bore with a stroke of 5 1-2 inches. The general details are similar to the motor of the "36" in all essential features. Clutch stops are fitted in the manner shown in Fig. 5 and the same remarks that were made in respect to the transmission of the smaller car apply to this model also.

The internal and external brakes are 2 inches larger in diameter, and the faces are 1-4 inch wider. The rear springs are 4 inches longer and have less arch, and the half springs are attached to gusset plates in a manner similar to that which obtains in the 36-horsepower chassis. In other respects the chassis is identical with last year's models, but the bodies are entirely of new design. The general appearance of the seven-passenger touring car fitted to the 48-horsepower chassis is shown in Fig. 4. The rear seat of this body is 54 inches wide and 21 inches deep; the height from the floor to the top of the cushion is 16 1-2 inches. The distance between the back of the front seat and the back of the rear seat is 40 1-2 inches, while the width of the front door is 20 1-2 inches and that of the rear door 22 inches. New folding extra seats in the tonneau are provided with arm rests. The additional space inside the body adds to the comfort of the occupants without in any way spoiling the appearance, which is decidedly clean-cut, as may be seen from the illustration.



Fig. 11—View of the new change speed sector and gear shifting mechanism, including the interlocking device

An interesting point in the body design of the new models lies in the fact that the running boards have been cleaned and the battery box is now slung under the body, the tools having been placed in a compartment built into the apron.

**The 66-Horsepower Model**

Mention has already been made of the new motor in this model, and suffice it now to mention that the bore is 5 inches with a stroke of 7 inches.

Two features on all Pierce-Arrow models have been retained, viz., the seven-bearing crankshaft and the lubricating system with the tank placed above the cylinders in the manner shown in Fig. 9.

In the new model there will be used larger diameter live rear axle jackshafts with fluted ends for attaching to the driving wheels and compensating pinions. It

will be possible in this model only to withdraw the live rear axle without taking the casing apart after withdrawing the hub and unscrewing the caps containing the bearing on the ends of the rear axle case. The brakes are 2 inches larger in diameter and the faces are 1-4 inch wider.

As in the other models the rear springs have been lengthened 4 inches. The radiators and hoods on all three models have been made higher, the "36" and the "48" being 1 1-2 inches and the "66" 1 inch higher than last year.

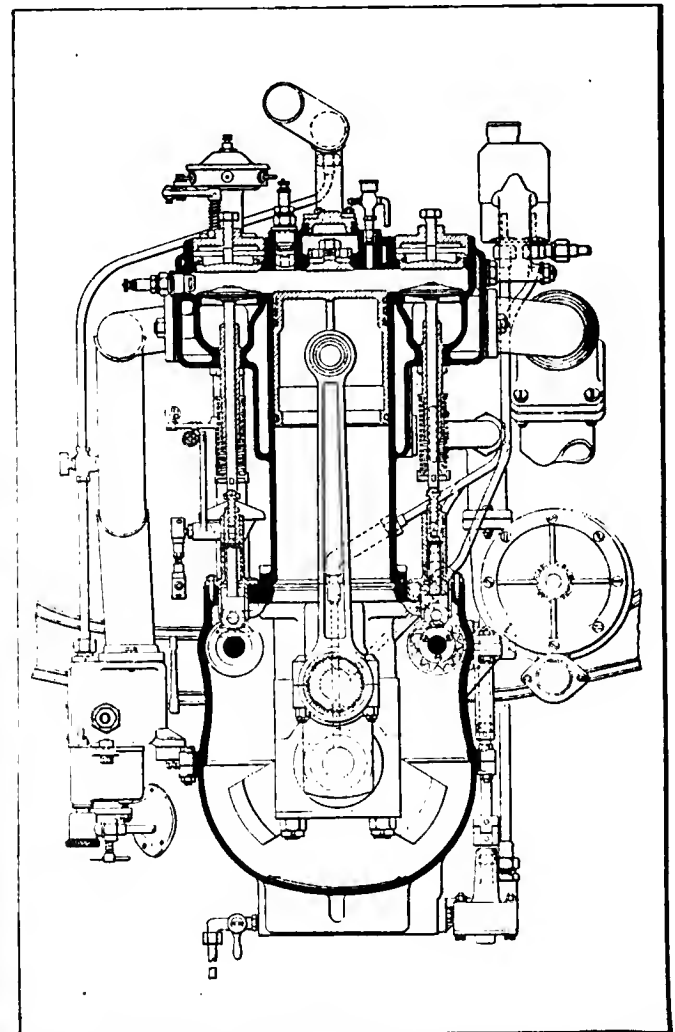

Fig. 12—Transverse section through the front cylinder of a Pierce-Arrow six-cylinder motor

# Refinements of 1912 Locomobile

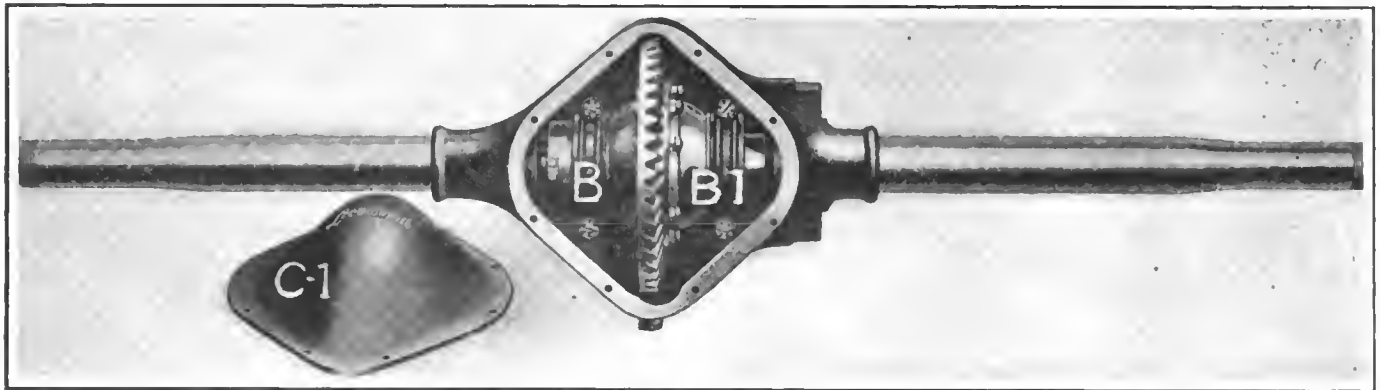

Fig. 1—View of the new live rear axle fitted to the Locomobile six with cover removed

WITH the exception of a few refinements, that would not be noticed by the casual observer, there has been no material difference in the new models of the Locomobile car, manufactured by the Locomobile Company of America, Bridgeport, Conn. The personal comfort of the occupants and the general appearance of the coachwork has received marked attention, with the result that the new models have been improved equally as regards the lines of the body, the interior finish and the upholstery.

To pass from the coachwork to the mechanical features of the car, the power plant of the 1912 Locomobile six differs but little from its predecessor. The same type of  $4\frac{1}{2} \times 4\frac{1}{2}$  T-head cylinders, cast in pairs, is used, and the motor, although rated at 48.6 horsepower, is claimed by the makers to develop somewhere in the neighborhood of 65 horsepower. The crankcase has

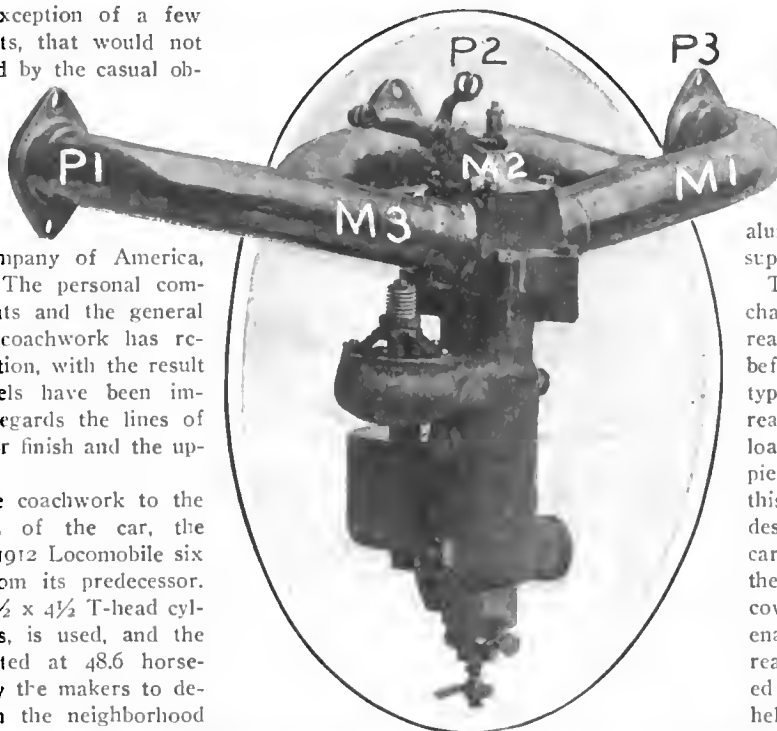

Fig. 2—General view of carbureter and manifold

been somewhat lengthened to accommodate slightly longer bearings for the pump and magneto shafts, and the attachment of the timing gears to their respective shafts has been modified. The magneto coupling has been enclosed in an aluminum cover to maintain a constant supply of grease to this part.

The most radical change of a mechanical nature is to be found in the rear axle and differential housing. As before, the live axle is of the floating type, which serves only to turn the rear wheels, carrying no part of the load. The axle housing is now a one-piece steel casting. In former years this was a two-piece axle. In the new design shown in Fig. 1 the weight is carried upon a single casting, whereas the large opening at the rear, ordinarily covered with an aluminum cover, enables the differential to be easily reached. The bearings, that are mounted on the extremities of the cage, are held in position by strap bars B and B1, which are secured by four bolts. By



Fig. 3—View of the interior of the limousine, showing the upholstery and extra seats folded away



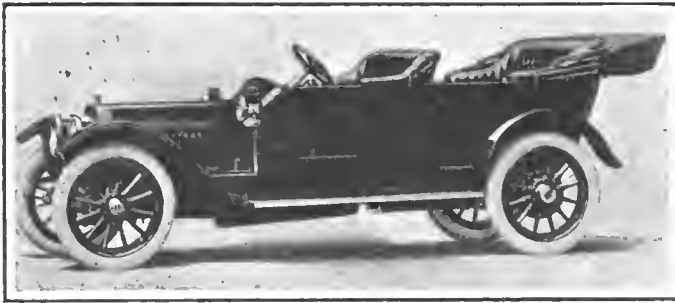

Fig. 4—Fore-door torpedo body to seat four passengers fitted to the Locomobile six chassis

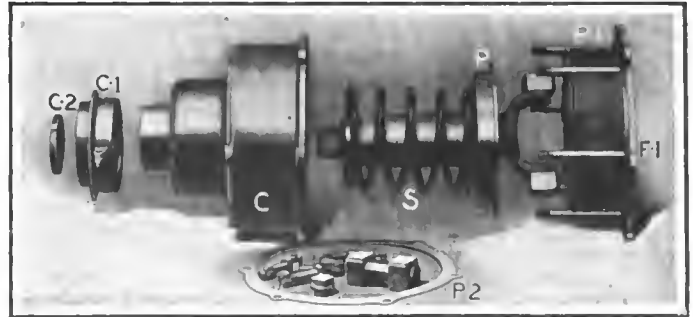

Fig. 5—Showing the various component parts constituting the Locomobile clutch

removing these bars the differential can be removed bodily from the casing after the axle driveshafts have been withdrawn sufficiently far through the axle tubes. Alloy steel tubes are pressed into the ends of the axle housing to form the weight-carrying portion of the dead axle. A pressure of several tons is used to force these into place, and rivets fasten tube and casing together.

The general appearance of both sides of the power plant of the six-cylinder motor can be obtained by referring to Figs. 13 and 14. Fig. 13 shows the exhaust side of the motor in which the exhaust manifold M is attached to a single port on each pair of cylinders. To heat the air before mixing with the gasoline an aluminum box B surrounds the manifold from which a pipe leads to the base of the carbureter. The water pump P takes the water from a large radiator placed in front of the motor and delivers it to two pipes P1 and P2. In order to maintain a steady flow to each pair of cylinders these pipes are attached to a central collecting pipe P3 so that the water passes to the cylinder bases W1, W2 and W3 at approximately the same pressure. One of the difficulties to be overcome in six-cylinder construction lies in the fact that each cylinder, or, as in the case of the Locomobile motor, each pair of cylinders, has to be fed equally both as regards cooling water and combustible mixture.

The use of spiral gears, made from chrome nickel steel, has been continued

for the timing gear wheels, with a slight improvement in the method of attaching them to the ends of the camshafts. Owing to the fact that the teeth are not parallel with the axis, large spiral gears when run under load produce a slight end thrust on the bearings. In other words the angle of the teeth creates a resultant force which does not act in the plane of rotation of the gear. The method employed in the new models of the car under notice is to finish off the ends of the camshafts with large face plates flanged so as to coincide with corresponding recesses in the hubs of the gears. The gears are then attached to the flanges on the camshafts by means of four cap screws which have a continuous wire passing through holes drilled in the heads of each to prevent them from shifting as a result of the engine vibration.

The crankshaft is mounted on seven main bearings, B1, B2, B3, B4, B5, B6, B7, as may be seen by referring to Fig. 11, and the upper half of the crankcase which carries the bearings is made from rigid and heavy government manganese bronze, which is a feature of Locomobile construction. To the bottom of this crankcase is attached the aluminum pan shown in the lower half of Fig. 11. Therein is contained the main oil reservoir. A spiral gear at the rear end of the exhaust camshaft drives a vertical shaft which operates the rotary pump P4 in Fig. 13. The oil flows by gravity from the well in the motor to the pump,



Fig. 6—View of the interior of the limousine, showing extra seats

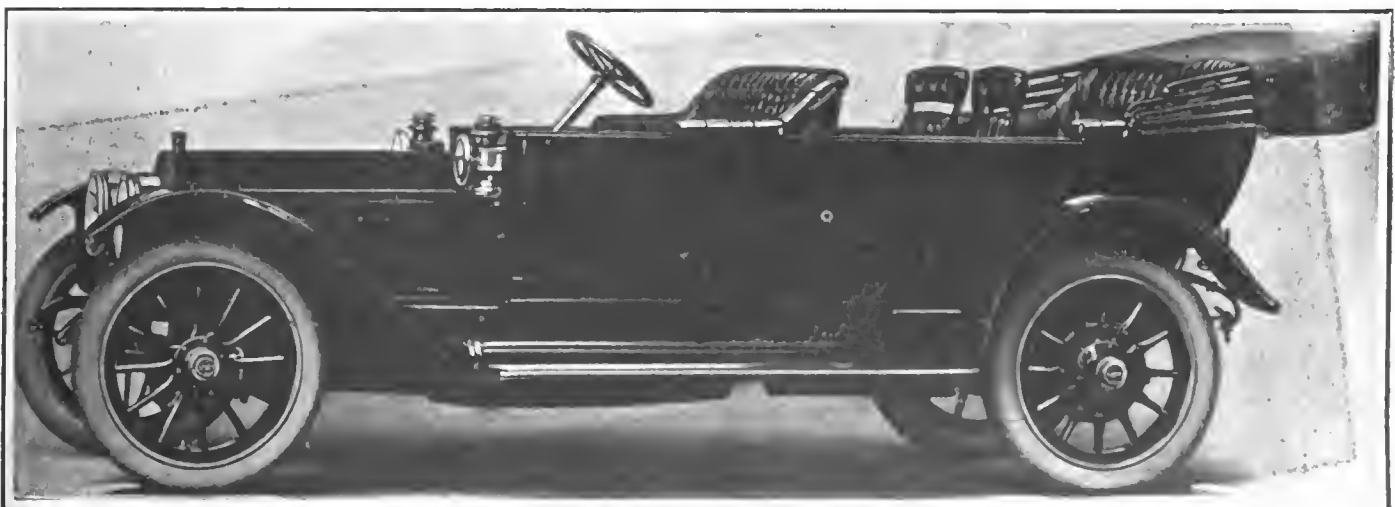

Fig. 7—General appearance of the new flush fore-door six-cylinder Locomobile seven-passenger touring body

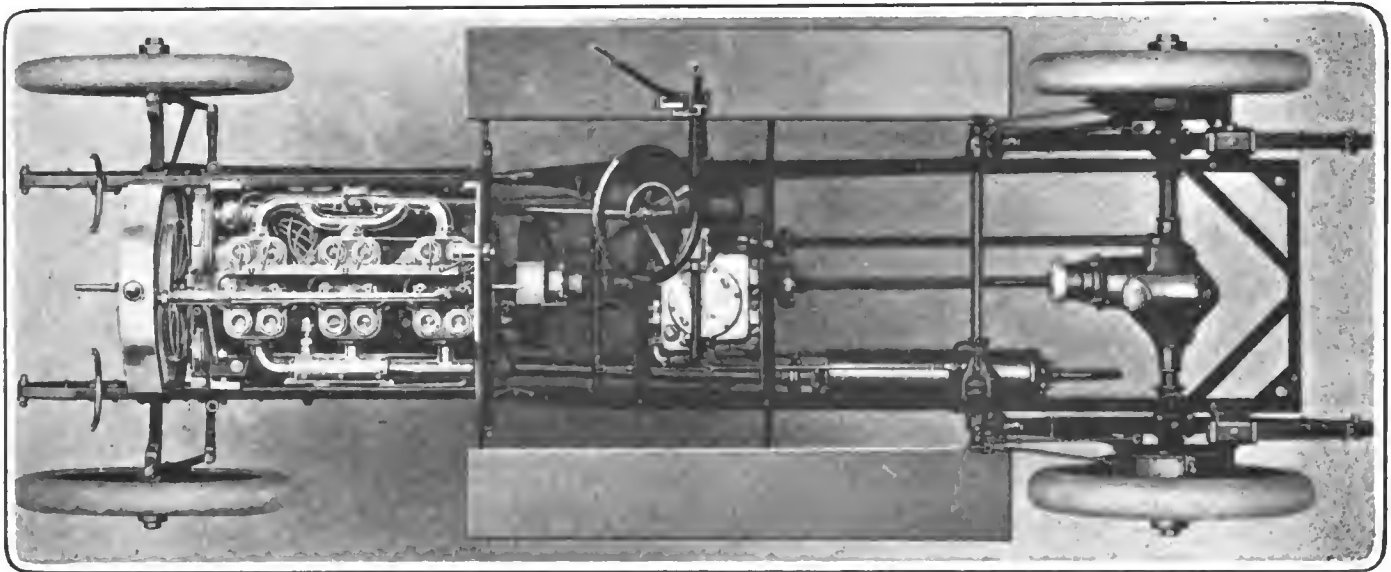

Fig. 8—Plan view of the Locomobile six, showing the arrangements of the various units

whence it is delivered under pressure to a T-connection. One end of this connection is attached to the main feed pipe O which passes along the side of the crankcase. Individual leads O1, O2, O3, O4 and O5, feed each crankshaft bearing as well as the camshaft bearings.

The second branch of the T connects with a pipe inside the base of the motor shown in Fig. 11, where the troughs T1, T2, T3, T4, T5 and T6, are situated. A hole in the oil feed-pipe keeps the troughs constantly filled with oil and the lower ends of the connecting rods being fitted with scoops, the oil is churned up sufficiently to lubricate the piston and cylinder. In order to prevent an undue amount of oil from reaching the cylinders, baffle plates are provided over the openings through which the connecting rods reciprocate. Inasmuch as the oil in each trough, into which the scoops dip, cannot exceed a certain depth, and as the baffle plates limit the size of opening through which the oil is sprayed, smoking troubles and their attendant consequences are minimized.

Part of the intake side of the motor is shown in Fig 14 from which it may be seen that the magneto rests upon a ledge cast integral with the upper part of the crankcase, and is held in position by means of a steel band and an easily removable connection. The coupling of the magneto in the new models is of the universal jaw-type as heretofore, but it is now encased in an aluminum covering which is packed with grease sufficient for a season's running. The leads to the sparkplugs are carried in the tube B and the method of attaching the intake manifold is also shown. The arm M3 leads to the rear pair of cylinders, and the lead M1 to the front pair. In order to equalize the flow the connecting arm of the manifold M2

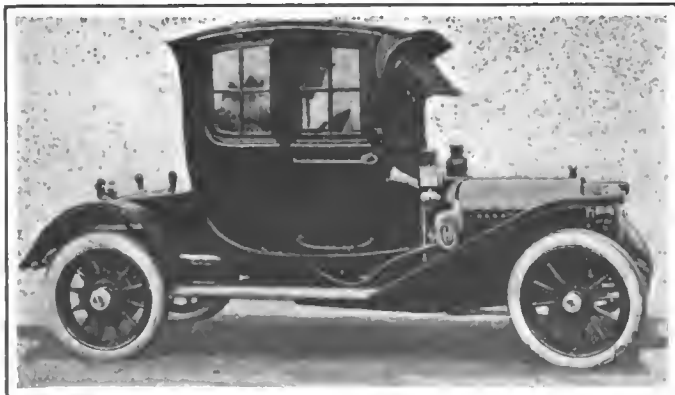

Fig. 9—Coupé body fitted to the Locomobile four



Fig. 10—Method of carrying baggage in waterproof-covered suit cases on the running boards

is attached midway in the forward and rearward arms and may be clearly seen in Fig. 2.

The carbureter, of the float-feed, constant-level type, employs a single tube through which passes the gasoline for all speeds of the motor; in other words, the functions of the needle valve and the auxiliary gasoline supply are performed by a single tube. In addition to the cone-shaped nozzle at the end, the pipe is perforated at the center of the strangling tube, and thus the supplementary openings for the low speeds are furnished.

The action of the auxiliary air valve V is simple and is controlled by a dashboard lever which serves as a convenient and efficient adjustment while the car is running. The action of the lever is to compress a second spring which opposes the action of the main spring so that the tension of the latter can be regulated to suit all conditions of weather. To assist the vaporization the mixing chamber is water-jacketed.

The gearset affording four ratios of gear is located amidships, and is of the selective type. Like the motor base the housing is of manganese bronze. The power of the motor is transmitted by means of a multiple-disc clutch, shown in Fig. 5, the flange F1 being attached to the mating boss on the flywheel. The pressure needed to keep the plates P1 and P2 to-

gether is furnished by the spring S, and the whole is enclosed by the cover C, the tension of the spring and the adjustment thereof being taken care of by the ring C2.

Two radius rods are attached at their rear ends by means of discs to the rear axle housing, forming covers for the brake drums, and at their forward extremities to the spring brackets. The torsion rod is of pressed steel mounted at the forward end in a vertical cylinder between two heavy springs. The combination of radius rods and torque member is intended to relieve the springs of pull and twist, permitting them to perform, unhindered, their work of supporting the weight of the car.

The suspension of the chassis is taken care of by semi-elliptic springs, at the front, 38 inches long and 2 inches wide, and at the rear by means of three-quarter elliptic springs 48 inches long and the same width as the front springs. When the car is loaded practically straight-line drive between the gearset and the differential obtains, as the propeller shaft revolves at an angle of about one degree with the crankshaft. Four universal joints are provided—two between the clutch and gearset and two between the gearset and live rear axle. The gasoline tank is situated below the driver's seat and has a capacity of 25 gallons. An auxiliary oil tank is placed alongside the gasoline tank and is provided with a shut-off cock.

The wheel base of the six is 135 inches, and the tires are 36



Fig. 12—View of the fore-door limousine fitted to a Locomobile six

x 41-2 for the front, and 37 x 5 inches for the rear wheels, fitted to demountable rims.

Figs. 3 and 6 show the upholstery of the limousine, which has been made very luxurious, particular care having been paid to the folding seats in order to make them as comfortable as possible. It is better to pay more attention to the upholstery of a car and fit ample cushions, thus relieving the passengers from road shocks, than to fit "soft" springs and thereby weaken this vital organ. The cushions of the rear seats are 10 inches deep and there are three rows of 8-inch springs in each of the three sections composing the back. The back of the rear seat is two inches higher than that of the one in front, and neither projects more than five inches above the sides and doors that form a continuous straight line from dash to rear of tonneau. The concealed hinges on which all doors are mounted serve to keep the exterior of the body free from any metal projections that would tend to destroy the color scheme or symmetry of the outline of the car. The lock on each door is operated only by means of a top lever, handles being thus eliminated from the outer surface of the body.

The running boards have been kept clear of all equipment or attachments. This has been brought about by carrying the two spare tires at the rear of the body, held in place by brackets against the back of the tonneau; by stowing the tools and battery under the floor boards at the back; and by placing the gasoline tank under the front seat. This arrangement not only adds greatly to the appearance of the car, but leaves the running boards, which are unusually long and commodious, free to carry such suit cases, trunks, or other baggage as may be required by the members of the touring party.

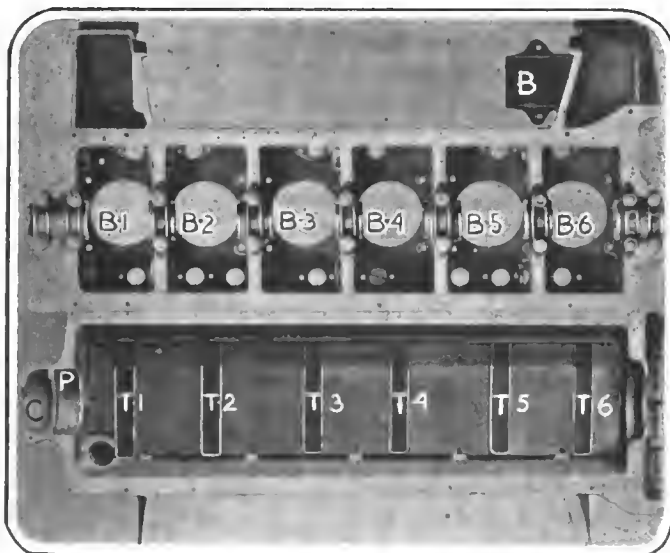

Fig. 11—Two views of the crankcase of the Locomobile six

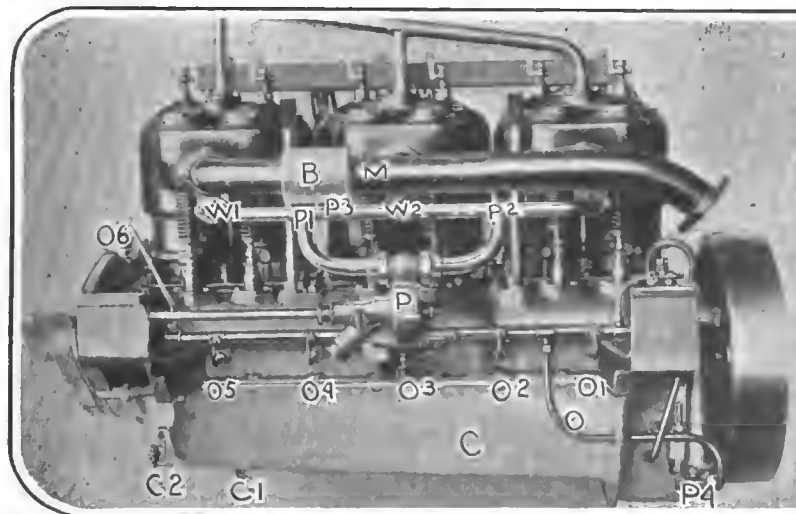

Fig. 13—View of the exhaust side of the Locomobile six motor

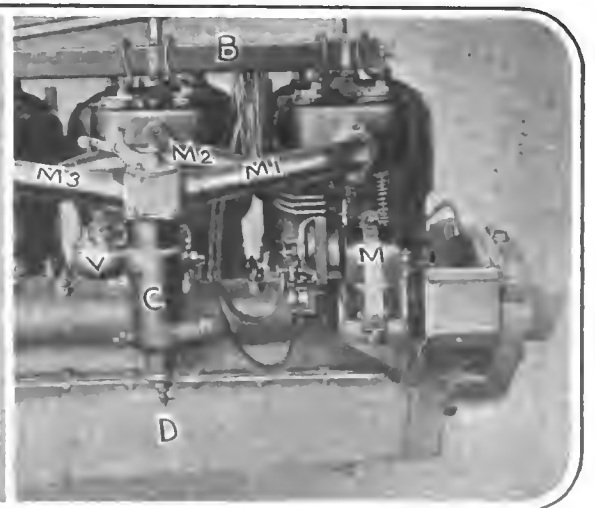

Fig. 14—Part of the intake side of the motor showing the magneto

# Automobile Scores in British Strike

LONDON, Sept. 6—The past fortnight has witnessed England disturbed in every quarter by the labor struggle—the carefully planned strike of railroad and transport workers which was calculated to disorganize every trade and thereby to hasten along the granting of the men's full demands. Unfortunately for the strike-leaders, they had forgotten to take into account the development of the automobile, and hence, in great measure, came the failure of their schemes. Now that the trouble is all over, it is consoling to reflect on the benefits that have accrued, to the public, in that the railway monopoly has been proved to be unimportant, and to the automobile industry, in that the value of the commercial vehicle has been demonstrated in the most thorough manner conceivable. Already, the results are showing themselves in a steady rush of orders from transport companies and from traders of all classes for trucks, vans and haulage tractors.

Undoubtedly, the strikers scored well at first, for the shortness of the warning notice caught the motor vehicle owners unprepared and the gasoline supplies were at a low ebb. However, within a week the motor services were in full swing, and, by dint of careful management, the fuel was made to last. At the first signs of the outbreak, the available reserves were bought up by the omnibus and transport concerns, and the main sufferers were thus the pleasure car and small van owners. As much as \$2.50 per gallon was regularly charged for gasoline at certain places, instead of the usual 25 cents, and resort had frequently to be made to kerosene, naphtha, alcohol and other possible, though undesirable, fuels. Here is another lesson which has been learned; everyone is now storing gasoline reserve supplies, and in case of further labor troubles or a war outbreak, there will be sufficient motive fuel for six months running.

A week before the railway stoppage commenced, the London carters ceased work, and they expected to paralyze the trade of the metropolis by their action. They were making a big mistake, for, at all the markets, the lumbering two-horse wagons were at once replaced by swift-moving motorvans, private cars, motorcycles and trailers, and, in short, every conceivable type of power vehicle. The work was carried on without any delay. The speed limit was abolished by general consent and it was possible to average over twenty-five miles an hour right through London. Under ordinary conditions, with the obstruction of horse-drawn vehicles, the speed would be little better than half. London has had its first experience of purely mechanical traffic, and so universally satisfactory have been the results that serious proposals are afoot for the limitation of the use of horsed vans and wagons to the evening and night hours.

Still another use for the automobile was found in Liverpool, where riotous happenings were experienced. Both the police and the military were severely damaged by the missiles—bricks, bottles and occasional bars of iron—thrown by the hooligans from the shelter of houses on the line of march. Accordingly, half a dozen three-ton goods trucks were equipped with substantial sides and tops of wood barricading, the radiator and all vulnerable parts were cased in, and these armored wagons then patrolled the disaffected areas with armed men on board. Quite a useful purpose was served by these vehicles, which were able to convey the majesty of the law right through the mob to the center of all disturbances, and yet to protect the police from cowardly assaults from the housetops.

Few as were the special road services instituted during the strike, they all, without exception, proved their utility in a remarkable way, demonstrating to the general public that, in a

country like England, where 200 miles is almost the longest normal journey for goods traffic, the power wagon and the road train can compete openly with the railway service.

To transport food supplies and perishable goods from the bas.s of supply to the distributing centers at a time of need would require at least ten or fifteen thousand motor vehicles. Such a number of trucks and lorries could not be mustered together and a proposal has therefore been brought forward, by Lord Montague, that *motorists should combine together in a big public service league, which would be so organized that when the time came, a sufficiency of cars and drivers would be available to meet any emergency.* The two British Clubs—the R. A. C. and the Automobile Union—have a membership of 50,000 *between them, and there would probably be not much difficulty in enrolling the required number of patriotic car owners.*

The strike has proved a godsend to the commercial motor vehicle industry, and all the well-known manufacturing firms are now booked right up for at least six months to come. Meanwhile, inquiries are pouring in and there is clearly enough available business to keep the whole of the trade well employed for a year or two to come.

As the existing firms are all fully occupied, the pleasure car manufacturers are hurriedly completing the plans which they have for several seasons been developing and the majority of the most important touring car firms will have their commercial vehicle section fully working by the Spring time. The one, three, and five-ton trucks are the popular fancies; the small pneumatic-tire van business is only attempted in a desultory sort of way—generally as a means of using up last year's pleasure car chassis. In this section, right away, there seems quite a good opening for the American manufacturer. Incidentally, it is interesting to note the comparative sales figures of commercial vehicle progress, obtained by one of the technical weeklies by confidential reports from the manufacturers. Taking the 1905 output as a basis with 100 as the figure, the 1907 figure is 201; by 1909 it slowly had increased to 315, while the estimated total for this present season is 620. Next year, according to the present outlook, should give a figure well over the 1,000 mark.

## Alco Rests on Its Laurels

The following self-explanatory statement has been issued by the American Locomotive Company:

"The American Locomotive Company has decided to withdraw from racing. Our reason for this action is that racing takes more time and attention on the part of our organization than we feel justified in devoting to it.

"This decision will not apply to commercial vehicles if properly arranged contests for such are planned in the future.

"The six-cylinder stock car with which Mr. Grant won the last two Vanderbilt Cup races has been presented to him by the company as an expression of our appreciation of his services to us."

## Wilby Reaches Chicago

CHICAGO, Sept. 11—Thomas W. Wilby, driving an Ohio car, who is on a 12,000-mile pathfinding tour in the interests of the Office of Public Roads of the Department of Agriculture at Washington and the Touring Club of America, reached Chicago Saturday, having come from New York. Reporting on the first leg of the journey, Mr. Wilby says: "As for the eastern sec-

tion of the transcontinental route, I found that New York State is macadamizing the whole of the Albany post road and the Mohawk Valley route. When completed they will make a fine system of highways. Ohio hasn't done much yet with its gravel highways, and we found very little macadam in Indiana, but the last-named State has some wonderfully straight, broad gravel roads, extending for miles across the level prairie-like country. They would make ideal highways at very little expense and trouble. Indiana certainly would confer a public boon upon motorists if it would put its road-making machines into operation. We were surprised to find what were little more than sandy trails near Michigan City on the way into Chicago."

### Grand Rapids' Motor Fire Equipment

GRAND RAPIDS, MICH., Sept. 9—Following its general policy of substituting motor-driven fire apparatus for the old style pulled by horses, the Board of Police and Fire Commissioners has awarded the contract for a new auto hosecart to the Seagrave Company, of Columbus, Ohio. The new machine is to cost \$3,950 and will be stationed at the new No. 12 engine house. The Michigan Hearse and Carriage Company of this city now is engaged in constructing the bodies for two chemical automobile machines to be installed at No. 1 and 3 engine houses. At No. 5 engine house there is a combination chemical hosecart and truck, Battalion Chief Walker has an official runabout and the board is figuring on letting a contract for a hook-and-ladder truck. It is the policy of the board to purchase the chassis from the automobile manufacturer and then have the body made in this city according to specifications made by the board. The police department at present has a motor-driven ambulance and patrol.

### See Pickens' Hand at Kansas City

According to officials of the Contest Board of A. A. A., the race meeting hitherto sanctioned for Kansas City, September 16-17, was declared off for rather a different reason than the one

announced. It was said that the track was in impossible shape for racing and that the reason for withdrawing the sanction was founded in that fact. It is now stated with some show of authority that the redoubtable "Bill" Pickens was the actual promoter of the meeting, using the name and personality of some person who was not in the had graces of the authorities. It is further stated that one or more of the racing cars owned or controlled by Pickens are being held on attachment in Kansas City because of certain preliminary obligations of a financial nature alleged to have been contracted by the promoter.

Pickens is quoted as saying that he had no intention of actually holding a race meeting, but merely wanted to show the public that he could get a sanction from A. A. A. The action of that body shows that "Bill" was wrong.

### New Homes for Everitt and Oakland

Announcement has been made that the Shepherd Motor Car Company which has handled the Oakland line in New York for several years, has taken on the Everitt. The full line of the Metzger company's production will be handled in the way of passenger vehicles and the new six-cylinder creation of the company will be on hand within two weeks.

The Oakland cars will be sold in New York by a factory branch which will be installed about October 1. The branch will be located on Broadway near the salesrooms of the Shepherd company.

### Riess Company to Move North on Row

C. E. Riess & Co., handling the Marion and American lines, will remove to the quarters formerly occupied by the New York branch of the Thomas at Sixty-third and Broadway. The change will be accomplished about October 1. Business has been extraordinarily good for the type of cars represented by the Marion during the past season, and the 1911 allotment has been oversold. Mr. Riess personally is at the factory trying to secure another shipment of cars.

## Calendar of Coming Events

#### Shows, Meetings, Etc.

- Sept. 25-30.....Atlantic City, N. J., Convention and Exhibition of the Carriage Builders' National Association.
- Jan. 1-5, 1912.....New York City, Grand Central Palace, Annual Show, Automobile Manufacturers' Association of America.
- Jan. 6-13.....New York City, Madison Square Garden, Twelfth Annual Show, Pleasure Car Division, Automobile Board of Trade.
- Jan. 10-17.....New York City, Madison Square Garden, Annual Show, Motor and Accessories Manufacturers.
- Jan. 10-17.....New York City, Grand Central Palace, Twelfth Annual Show, National Association of Automobile Manufacturers.
- Jan. 15-20.....New York City, Madison Square Garden, Twelfth Annual Show, Commercial Division, Automobile Board of Trade.
- Jan. 18-20.....New York City, Annual Meeting of the Society of Automobile Engineers.
- Jan. 27-Feb. 10....Chicago Coliseum, Eleventh Annual Automobile Show under the auspices of the National Association of Automobile Manufacturers. Pleasure cars, first week. Commercial vehicles, second week. Accessories, both weeks.
- March 2-9.....Boston, Mass., Tenth Annual Show, Boston Automobile Dealers' Association, Inc.

#### Race Meets, Runs, Hill-Climbs, Etc.

- Sept. 12-15.....Omaha, Neb., Third Annual Endurance Run, Omaha Motor Club.
- Sept. 15.....Knoxville, Tenn., Track Races, Appalachian Exposition.
- Sept. 16.....Syracuse, N. Y., Track Races, Automobile Club and Dealers.
- Sept. 18-20.....Chicago, Ill., Commercial Reliability Run, Chicago Motor Club.
- Sept. 19.....Burlington, Vt., Reliability Run, Merchants' Protective Association.
- Sept. 23.....Philadelphia (Point Breeze), Track Races, Philadelphia Automobile Trade Association.
- Sept. 23-25.....Detroit, Mich., Track Races, Michigan State Agricultural Society.

- Sept. 30.....Guttenburg, N. J., Track Races.
- Sept. ....Steubenville, O., Hill Climb, Automobile Club of Jefferson County.
- Sept. ....Denver, Col., Track Races, Denver Motor Club.
- Oct. 6-13.....Chicago, Ill., Thousand-Mile Reliability Run, Chicago Motor Club.
- Oct. 7.....Danbury, Conn., Track Races, Danbury Agricultural Society.
- Oct. 7.....Philadelphia, Fairmount Park Road Races, Quaker City Motor Club.
- Oct. 7.....Springfield, Ill., Track Races, Springfield Automobile Club.
- Oct. 13-14.....Atlanta, Ga., Track Races.
- Oct. 14.....Santa Monica, Cal., Road Races.
- Oct. 14 (to 25)....New York City, Start of the Annual Glidden Tour, en route for Jacksonville, Fla.
- Oct. 16-18.....Harrisburg, Pa., Reliability Run, Motor Club of Harrisburg.
- Nov. 1.....Waco, Tex., Track Races, Waco Auto Club.
- Nov. 2-4.....Philadelphia, Reliability Run, Quaker City Motor Club.
- Nov. 4-6.....Los Angeles, Phoenix Road Race, Maricopa Auto Club.
- Nov. 9.....Phoenix, Ariz., Track Races, Maricopa Automobile Club.
- Nov. 9, 10, 12....San Antonio, Tex., Track Races, San Antonio Auto Club.
- Nov. 27.....Savannah, Ga., Vanderbilt Cup Race, Savannah Automobile Club.
- Nov. 30.....Los Angeles, Cal., Track Races, Motordrome.
- Nov. 30.....Savannah, Ga., Grand Prize Race, Savannah Automobile Club.
- Nov. ....Columbia, S. C., Track Races, Automobile Club of Columbia.
- Dec. 25-26.....Los Angeles, Cal., Track Races, Motordrome.

#### Foreign Fixtures

- Sept. 10-20.....Hungarian Small-Car Trials.
- Sept. 16.....Russian Touring Car Competition, St. Petersburg to Sebastopol.
- Sept. 17.....Semmering, Austria, Hill Climb.
- Sept. 17.....Start of the Annual Trials Under Auspices of *l'Auto*, France.
- Nov. 3.....London, Eng., Olympia Show.





Vol. XXV Thursday, September 14, 1911 No. 11

THE CLASS JOURNAL COMPANY

H. M. SWETLAND, President

CONDE NAST, Vice-President and General Manager

E. M. COREY, Secretary and Treasurer

231-241 West 39th Street, New York City

Cable Address - - - - - Autoland, New York
Long Distance Telephone - - - - - 2046 Bryant, New York

SUBSCRIPTION RATES

United States and Mexico - - - - - One Year, \$3.00
Other Countries in Postal Union, including Canada - - - - - One Year, 5.00
To Subscribers—Do not send money by ordinary mail. Remit by Draft,
Post-Office or Express Money Order, or Register your letter.

Entered at New York, N. Y., as second-class matter.
The Automobile is a consolidation of The Automobile (monthly) and the Motor
Review (weekly), May, 1902, Dealer and Repairman (monthly), October, 1903,
and the Automobile Magazine (monthly), July, 1907.

The Winter Automobile

MORE attention is being paid among automobile makers this fall to the winter body than ever before. Some years ago many automobile makers built nothing but open touring or runabout bodies. Then a demand grew for an enclosed type, and the limousine came into being. This was soon followed by the landaulet, which came as a combination open-closed type. Following this came the coupé. At present much attention is being bestowed on a special type of enclosed car for the owner-driver who wants to sit at the steering wheel himself for his winter trips, but who does not want to be separated from his family by a plate glass partition. The demand for this style of car will be a most appetizing one in a year or so. Such a car type is the limousine for the middleman, the owner who does not want a chauffeur, but who wants to take his family to the theatre, to church or for an outing. The body is a one-compartment type, with room between the two front seats for a passage to said seats.

The chief objection in the past to this type of body has been the entrance to the front seats. It has demanded a double set of doors—one for the front seats, the other for the back seat. This has been expensive, too expensive to be exploited in the medium-price field. The solution has been in the wider body for the front seats. Some builders are making the body at this point as wide as the tonneau at the rear. This has been made possible by adding body plates which project out from the frame members at each side and on which the body rests. This extra width allows of two wide front seats with a good passage between them. With this design but two doors are customary, but one only is actually essential; it should be on the right side, as in all the larger cities the traffic ordinances require a vehicle to stop with the right side to the curb.

With modern body constructions every possibility in the way of individuality of seating is obtainable in a one-compartment winter body. The interior arrangements depend entirely on the owner's requirements. Small supplementary seats for children can be located in

almost any part of the compartment. A common practice is to arrange one folding seat at the left end of the dash, where ordinarily there is plenty of room for it.

One detail overlooked in many winter cars is the heating arrangements. No provision is made for heat in the majority of the types, and in cold weather it is necessary to use heaters which are placed on the floor. These are good; but, in addition to them, there is no reason why a part of the exhaust cannot be utilized for this work. The automobile is a heat machine; the engine must keep very warm to work well. At present much of this heat goes off through the muffler, and a portion could be used to keep the compartment at any desired temperature. Some makers have put small exhaust radiators in the car floor: others have hot-air-jacketed a part of the muffler and led the air through this jacket before getting it into the compartment. All are good, yet it seems that the good work has not been carried far enough. The man buying an enclosed winter car for \$2,000 or less wants a little heat as well as the owner in his \$4,500 limousine. The extra cost has not been the prohibition; rather it has been the fact that the maker has not done it. He has reasoned that it has not been demanded, and then why should he install it? This is short-sighted logic; it is the same logic that some makers used in conjunction with the fore-door body; they did not install it until demanded and then found out that they were six months behind the times. In heating winter bodies, the car maker should keep up with the times, and if he errs let him err in being ahead of the times rather than in being in the rear.

It is not entirely with enclosed cars that the critic sees the comforts of the car owner being looked after more than ever in the 1912 cars. Many makers have taken up the matter in open touring cars and runabouts. Not a few factories have enhanced the luxuriousness of the upholstery almost 100 per cent. for the coming season. This administers directly to the comfort of the owner and his family. The upholstery has been inadequate on many cars; it has sufficed at the start, but soon became hard.

There is yet much room for improvement in the comfort-administering details of the car body. Who has not ridden in the rear seat of a seven-passenger car and had his legs cramped in order to get his feet on the inside or on the outside of the supports for the extra seats? It frequently happens that if the passenger sits at the right end of the rear seat he has to constantly cramp his feet to the inside of the auxiliary seat rest, whether the seat is folded away at the side of the tonneau or in use. If the designer of the seat would take a 100-mile ride some day in such a car he would immediately get back to the factory to design a rational extra tonneau seat. In other cases the extra seat is so close to the rear seat that the rear-seat passengers have not room enough and their shins are constantly rubbing against the back line of the extra seat. This is equally bad and it is astonishing that body designers will allow such body jobs to be sold to the public. It is almost a certainty that the designer has never taken a long trip in such a seat. It may be argued that such seats are not intended for long trips, but any man with experience in long-distance touring will agree that it is more comfortable to ride all day in a comfortable extra tonneau seat than it is in the tonneau seat itself.

## Gossip of the Coming Shows

**A**LLOTMENTS of space at all the shows sanctioned by the Motor and Accessory Manufacturers will be made October 7 when that organization assembles in New York. The M. & A. M. has sanctioned the Garden Show of the A. B. of T.; the Palace Show of the N. A. A. M.; Boston pleasure and commercial shows and the Chicago National Show.

The organization now has 222 members and has on file about a score of applications for membership. It is expected that practically 150 of these concerns will have space at the New York shows and about the same number at Chicago. The Boston shows always have a large number of locally made accessories that are not shown elsewhere, but the indications are that there will not be more than 150 M. & A. M. concerns there.

Drastic action against independent manufacturers who have exhibited at unsanctioned shows in the past has not been contemplated and in fact the independents will have a chance to exhibit their wares at the big shows.

The basement of the Garden will be used largely by exhibitors who are not members of the M. & A. M. and there will also be some space in the galleries for such concerns. There is no reason why those who have exhibited at unsanctioned shows may not take advantage of the open-door attitude that exists among the authorities.

While the drawings for space have been made as far as the A. B. of T. show are concerned, there are so many alterations to be made in the interior arrangement of the Garden that there may be a number of changes in spaces. This matter is now in

the hands of the architects and the final arrangement may not be absolutely fixed for several weeks.

The drawing for space for the Palace Show will take place October 4. It is predicted that this affair will prove the largest and most complete automobile exhibition ever held under the designation "Palace Show."

The independents who exhibited at the unsanctioned show last year are eligible for reinstatement or have been reinstated and several of the more prominent companies that took part have applied for space. The rule of the N. A. A. M. was that suspension for 18 months must follow violation of the rule against participation in unsanctioned events, but this rule has been so modified that nobody shall be barred.

The show contemplated by the Automobile Manufacturers' Association of America, and which was tentatively scheduled for the Palace, is shrouded in some uncertainty. Secretary Longendyke and the association have offices at Forty-fourth street and Fifth avenue, but on Tuesday noon, when a representative of THE AUTOMOBILE called there, the door was locked and the elevator starter imparted the information that Mr. Longendyke was out of town.

Nothing definite has been announced recently about the show and it is pretty widely rumored that the original date for holding it has been postponed. In the absence of Mr. Longendyke this could not be confirmed.

It is freely predicted that the show season of 1912 will be larger and better than any of its predecessors.

### New N.A.A.M. Members

**A**T its recent meeting the N. A. A. M. elected the following to membership:

J. I. Hanley, representing American Motors Company, Indianapolis, Ind.

G. A. Matthews, representing Jackson Auto Company, Jackson, Mich.

C. H. Walters, representing DeTamble Motors Company, Anderson, Ind.

F. H. Dodge, representing Ohio Electric Car Company, Toledo, Ohio.

A. B. C. Hardy, representing Marquette Motor Company, Saginaw, Mich.

George E. Daniels, representing Oakland Motor Car Company, Pontiac, Mich.

T. A. Campbell, representing Imperial Auto Company, Jackson, Mich.

T. F. Hart, representing Inter-State Automobile Company, Muncie, Ind.

Charles D. Hastings, representing Hupp Motor Car Company, Detroit.

D. A. Shaw, representing Simplex Motor Car Company, Mishawaka, Ind.

W. J. Groves, representing Mack Bros., Motor Car Company, Allentown, Pa.

Fred W. Haines, Regal Motor Car Company, Detroit, Mich.

R. C. Hupp, representing Hupp Corporation, Detroit, Mich.

Rauch & Lang Carriage Company, Cleveland, Ohio.

Thomas Henderson, vice-president of the Winton Motor Carriage Company has resigned as a member of the Executive Committee of the N. A. A. M. Charles W. Churchill was elected in place of Mr. Henderson. Suitable resolutions of regret were ordered engrossed and spread upon the minutes of the organization and Mr. Henderson was unanimously chosen to be an honorary member of the committee.

### To Test License Right

**R**EGARDING the basic principles involved in licensing of automobiles, the N. A. A. M. has issued the following official statement with regard to its intentions to have the legal status established:

"It was decided that what has been known as the New Jersey Test case shall be carried to the Supreme Court of the United States. This is a case instituted five years ago, designed to show that no State or any other power may constitutionally demand that an automobilist take out a license. The case was started in the lower courts and has progressed step by step, the decision in each case being adverse. This was expected, and indeed hoped for, so that the question might, in due course, reach the highest court."

### M. C. A. Defines Grade 4 Contests

When the Active Rules Committee of the M. C. A. met last week it was decided to amend the contest rules so that the Glidden Tour this fall could be entered with other than registered stock models. At the Detroit meeting of the M. C. A. a resolution was recommended to widen the field for Grade 4 contests by making registration unnecessary in that grade on and after January 1, 1912. The recent action of the Rules Committee merely advances the date of the rule's operation.

### Winter Show for Worcester

WORCESTER, MASS., Sept. 11—Owing to the success of the Licensed Dealers' show, recently held in this city, arrangements are being made to hold a larger and more complete exhibition in the Worcester Auditorium during the coming Winter. A feature of the recent show, which was held under tents at the New England fair, was the exhibit of commercial vehicles, given in a specially constructed tent.



Start of the Flanders 20 Glidden Pathfinder from New York City en route for Jacksonville, Fla.

**NEW YORK**—The practicability of inter-city trucking service was demonstrated recently by the run which a brand new Commer truck made from Brooklyn to Philadelphia. The fully loaded Commer left Brooklyn at midnight, September 6, and arrived at its destination at 9 in the morning, two stops being made on the way. The average running time was 14 miles per hour.

**MILWAUKEE, WIS.**—A. McNeil, 161 Michigan street, has been appointed distributor of the Liberty Brush.

**SHEBOYGAN, WIS.**—The Erie Garage Company has been appointed district agent for the Hupp-Yeats electric line.

**GRAND RAPIDS, MICH.**—The name of the Buick Sales Company has been changed to the Grand Rapids Auto Company.

**PORTLAND, ORE.**—E. W. Vogler, president of the Northwest Auto Company, Portland, has added another agency to his long list. His latest acquisition is the Stearns.

**SPOKANE, WASH.**—Vance Wolverton, C. E. Lane and J. A. Munson are associated in the Spokane Everitt Motor Company, the latest invader of Spokane's auto row.

**SACRAMENTO, CAL.**—The city of Sacramento, Cal., has purchased two motor cars for use in its fire department service. This makes five purchased by that city in the last four years.

**SPOKANE, WASH.**—Harry Olive, formerly connected with Norman Church, the Southern California Stoddard-Dayton distributor, will hereafter handle the Overland cars in Spokane, Wash.

**SYRACUSE, N. Y.**—J. A. Seitz, head of the Abbott-Detroit agency in Syracuse, is having a large new building put up, corner Jefferson and Warren streets. He will move into this about December 1.

**SAN FRANCISCO, CAL.**—The U. S. Tire Company has opened temporary quarters at 414 Van Ness avenue, San Francisco. A new building is being erected for this company at 636-646 Van Ness avenue.

**BOSTON, MASS.**—Stanley G. Martin is now in charge of the Decatur truck branch in Boston, and he has had the business moved to the new maintenance department the company has opened in Cambridge.

**BOSTON, MASS.**—Arthur G. Johnson, formerly with D. P. Nichols & Co. when it handled the Frayer Miller trucks, is now sales manager of the Eastern Motor Truck Company, distributors for the Kelly truck.

**MILWAUKEE, WIS.**—An ordinance has been passed by the Common Council of this city forbidding the practice of cutting out the muffler in the city limits. The penalty for violation is a fine of \$25.

**MILWAUKEE, WIS.**—The Franklin Auto & Supply Company, 321-323 Fourth street, agent for the Franklin and Regal, has been appointed State agent for the Curtis, Farman and Bleriot type of aeroplanes.

**BOSTON, MASS.**—The Hollander Automobile Company has opened salesrooms at 169 Huntington avenue, where it is handling the Metz car, made in Waltham. The local agency has the New England field for this make.

**COLUMBUS, OHIO**—J. B. Hoover, who has been operating a stamping works and machine shop at 619-621 North High street, has taken the Central Ohio agency for the Nyburg automobiles, manufactured in Anderson, Ind.

**LOS ANGELES, CAL.**—John W. Swan, who for the past three years has been connected with the Leon Shettler Company, of Los Angeles, has taken the position of sales manager for the Reo Pacific Company in San Francisco.

**YORK, PA.**—W. Archie Miller, West Market street, has opened an automobile garage and repair shop in the brick building at 308 West Mason avenue. Mr. Miller was formerly employed by the Snyder Auto Company, this city.

**DELAWARE, OHIO**—D. F. Boston, of Bowling Green, Ohio, has opened a vulcanizing plant in the Pickering block. Boston had been conducting a similar business in Bowling Green, but sold out to open the shop in Delaware.

**GRAND RAPIDS, MICH.**—A new fireproof garage has just been completed at 249 Lake avenue for Ed. Mosher. The basement is fully equipped for repair work, while the first and second stories will be used almost exclusively for storage.

**COLUMBUS, OHIO**—The Main estate has begun the construction of a large garage in the rear of the Neil House, Columbus, Ohio, which will be leased to an operating company to be announced later. The garage will be 63 x 96 feet.

**COLUMBUS, OHIO**—H. R. Leach & Co., located in the Exchange Building on Taylor avenue, have taken the Central Ohio agency for the Lambert friction transmission trucks, manufactured by the Buckeye Manufacturing Company, of Anderson, Ind.

**SAN FRANCISCO, CAL.**—Two more new cars are to be represented in San Francisco. The Pathfinder and Parry are the new entries in the California field. They will be handled in San Francisco by the Motor Car Manufacturers' Sales Agency.

**TOLEDO, OHIO**—H. P. Robinson, of Toledo, has been placed in charge of the general agency of the Packard Motor Truck Company, with headquarters at Milwaukee, Wis. He was formerly connected with the New Era Paint & Varnish Company, of Toledo.

YORK, PA.—Bids for the manufacture of the State automobile license tags will be opened on September 19 by the State Highway Commissioner. Close to 42,000 tags have been issued this year and it is estimated that fully 50,000 will be required for next year.

BRISTOL, CONN.—The New Departure Manufacturing Company is sending out to all those who desire data sheets regarding ball bearings. The sheets also include stress tables and diagrams and are of such size that they can be inserted in the S. A. E. handbook.

COLUMBUS, OHIO—A contract has been made with the Ford Automobile Company to rent five of its runabouts to mail collectors of Columbus, Ohio, for the purpose of collecting mails. The cars will be placed in service as soon as they can be properly equipped and manned.

MILWAUKEE, WIS.—The Stegeman Motor Car Company has appointed the Schreiber Motor Car Company, 180 Fifth street, as Western distributor and local representative. The company builds a line of trucks from one to six tons capacity, with a guarantee of 25 per cent. overload.

FOSTORIA, OHIO.—Henry J. Adams and four other members of his family, including two children of two and four years of age, encircled Lake Michigan in a Reo, 1911 car. Their trip of 1,700 miles has just been completed and the whole party of five greatly enjoyed the unique experience.

TOLEDO, OHIO—The McLeary Engineering Company, of Toledo, has closed a deal which gives it the exclusive selling rights in Toledo territory on the Mais motor vehicle. X. D. Johnson, formerly with the Croxton-Keeton Company, will have charge of the automobile department of the company.

PHILADELPHIA, PA.—A. M. Pearson, of this city, will soon assume the management of the St. Louis Franklin branch. Mr. Pearson originally handled the truck business of the Packard Motor Car Company, of this city, and was later manager of the truck department of the White Company in Boston.

GRAND RAPIDS, MICH.—Since Messrs. Stratton & White have decided to handle the Hudson as well as the White cars, they have changed the name of the concern from the White Motor Company to the Stratton & White Auto Company. The entire floor space will be devoted to the storage of cars.

INDIANAPOLIS, IND.—A. E. Creeger, of Cleveland, Ohio, has been installed as manager of the new factory sales branch of the White Automobile Company. The Archey-Atkins Company, of Indianapolis, has been appointed agent for the Hudson "33," succeeding the agency held by the Indiana Automobile Company, which has taken on the Reo.

COLUMBUS, OHIO—Harry Joseph, who formerly operated a livery stable at the corner of Champion avenue and Oak street, has reconstructed the building into a modern garage. The second floor will be used for the storage of cars, while the garage proper and repair department will be on the first floor. The main entrance to the building is on Champion avenue.

INDIANAPOLIS, IND.—Stockholders of the Mais Motor Truck Company held their annual election of directors a few days ago, the following new directors being selected: Dr. Albert E. Sterne, John T. Sautler, A. W. Markham, C. L. Chandler, W. H. Roberts and Albert Mais. H. W. Moore, formerly cashier of the Capital National Bank, has been appointed assistant treasurer of the Mais Company.

MILWAUKEE, WIS.—The Rambler garage at 455-457-459 Broadway, Milwaukee, Wis., will cease to be a public garage as soon as Alfred Reeke, sales manager of the Milwaukee branch of the Thomas B. Jeffery Company, is able to make the arrangement. The policy of the Kenosha Company is to make all of its branches Rambler service stations exclusively, with no side lines.

SAN FRANCISCO, CAL.—A three-ton Kissel truck was used recently to transport grapes from Globe, Cal., to this city. The distance is 315 miles and the run was made in 31 hours. Fears were entertained that the 7,240 pounds of grapes could not be transported in the motor truck without bruising them, but they arrived in perfect condition, although the roads encountered were very rough and difficult.

## Automobile Incorporations

### AUTOMOBILES AND PARTS

BAY CITY, MICH.—National Motor Truck Co.; capital, \$300,000; to manufacture and sell freight automobiles.

BIRMINGHAM, ALA.—Birmingham Automobile Company; capital, \$10,000; to make motor vehicles. Incorporators: John B. Ransom, Geo. Beinnie, B. J. Banks, Jr.

CANTON, OHIO—Wise-Green Motor Car Co.; capital, \$25,000; to make automobiles. Incorporator: K. P. Wise.

CLEVELAND, OHIO—Yale Cycle and Supply Co.; capital, \$10,000; to manufacture, sell and repair motor vehicles and accessories. Incorporators: C. H. Ferguson, Laura A. Ferguson, Edward E. Tompkins, H. S. Jackson, H. E. Tiggle.

DETROIT, MICH.—Morton Motor Car Company; capital increased from \$5,000 to \$10,000.

DONALDSONVILLE, LA.—Donaldsonville Auto Company, Ltd.; capital, \$10,000; to make and deal in automobiles. Incorporators: K. A. Aucoin, Dr. S. Moore, Dr. V. Painhaud.

JOLIET, ILL.—Joliet Auto Truck Co.; capital, \$10,000; to manufacture and deal in automobiles and accessories. Incorporators: Phil F. Carroll, Milo M. Case, Wilbur O. Dayton.

PIQUA, OHIO—Piqua Motor Co.; capital, \$50,000; to manufacture automobiles. Incorporators: L. H. Wessel and others.

### AUTOMOBILE GARAGES, ACCESSORIES, ETC.

ANDERSON, IND.—J. H. Cloud Top Company; to manufacture parts; capital, \$10,000. Incorporators: J. H. Cloud, W. A. Hester, P. B. O'Neil.

BUFFALO, N. Y.—Eureka Seat Company; capital, \$10,000; to manufacture automobile parts and seats. Incorporators: Joseph H. Morgan, Maurice J. Cogan, Norbert C. Kropp.

BOSTON, MASS.—Richmond Garage & Motor Company; capital, \$15,000; to conduct a general garage business. Incorporators: Henry L. Richmond, Benj. V. Stevenson, Geo. W. Boland.

CLEVELAND, OHIO—Jepson Brothers Company; capital, \$5,000; to deal in automobiles and motorcycles. Incorporators: James E. Sayne, Peter G. Jepson, Anna D. Jepson, Richard J. Jepson, Minnie A. Jepson.

ELKHART, IND.—Brown Sales Co.; to deal in accessories; capital, \$5,000. Incorporators: Walter Brown, Beryl Brown, E. A. Skinner.

INDIANAPOLIS, IND.—Auto Lighting & Electric Company; capital, \$3,000; to make vehicle lights. Incorporators: G. S. Monfort, C. R. Brown, F. C. Parker.

JERSEY CITY, N. J.—Mechanical Rubber Tire Company; capital, \$100,000; to manufacture tires and other rubber goods. Incorporators: Wm. T. Wheeler, Frank B. Crawford, Frederic Carter.

KANSAS CITY, MO.—Lawrence Automobile Brake Company; capital, \$2,000. Incorporators: R. E. Bowen, Virgil Lantz, W. O. Sonum.

MONTPELLIER, IND.—Automobile & Supply Company; capital, \$5,000; to deal in automobiles and supplies. Incorporators: E. E. Helm, J. F. Ireland, L. Ireland.

PHILADELPHIA, PA.—Detroit Electric Car Company, of Philadelphia; capital, \$25,000; to buy and sell electric vehicles. Incorporators: A. M. Garrison, I. Morgan Russell, Amos S. Flowers.

SPRINGFIELD, ILL.—Packard Motor Car Co.; capital, \$50,000; to manufacture and sell automobiles. Incorporators: Leslie L. Ayer, William Fogel, William L. Barnum, Jr.

UTICA, N. Y.—Utica Auto Supply Company; to manufacture and deal in auto supplies; capital, \$10,000. Incorporators: Howell D. Crim, Chas. S. Burrows, Oscar J. Brown.



The Packard special camping motor truck

# OF INTEREST *to the* INDUSTRY



New R. C. H. car starting on long demonstration

**DETROIT, MICH.**—The R. C. H. runabout, a new creation of the Hupp Corporation, has started on its initial trip over the roads of Michigan. In the first three days the car covered 598 miles without developing any defects, making the run from Detroit to Grand Rapids, a distance of 162 miles, against the hilly and sandy roads between these points in good shape.

**CHICOPEE FALLS, MASS.**—O. C. Curtis, formerly of the Franklin Motor Car Co., will represent the Stevens-Duryea Co. in the South.

**PORTLAND, ORE.**—The Braly-DuBois Co., dealers in Franklin cars, will move to Nineteenth street, north of Washington street, on Sept. 15.

**NEW YORK.**—A new entry to the auto supply field, under the name of A. J. Picard & Co., will be located at 1720 Broadway after Sept. 22, 1911.

**WASHINGTON, D. C.**—W. C. Vliet, formerly assistant sales manager of the Buick Motor Co., has been appointed manager of the local branch of the E. M. F. Co.

**AMESBURY, MASS.**—The Graves & Congdon Co., manufacturers of the patent luxury automobile folding seat, have been reorganized under the name of the Hodge & Graves Co.

**PORTLAND, ORE.**—F. T. Bolton, formerly superintendent of the repair department of the Portland Automobile Company, has been promoted to the position of manager, taking the place of Ross B. Cooper, resigned. Mr. Bolton has been in the employ of the Winton Company for a number of years.

**CHICAGO, ILL.**—The Colby Motor Co. has opened a branch at 2009 Fullerton avenue. It will be under the management of W. H. Ogren, formerly of the Logan Auto Garage Co.

**PONTIAC, MICH.**—The estimated output of the Oakland Motor Car Co. will be between 5,000 and 6,000 of the 1912 model. No shutdowns or layoffs are expected during the ensuing year.

**BRISTOL, CONN.**—Samuel B. Dusenberre, formerly with U. S. Motors Co., is now Western sales manager for the New Departure Manufacturing Co., makers of ball bearings. He will be located in the Ford Bldg.

**ADRIAN, MICH.**—Leslie B. Sanders, until recently sales manager of District B, United States Motor Co., has accepted a position in the same capacity for the Lion Motor Co. and has just entered upon his duties.

**DETROIT, MICH.**—P. W. Hood, formerly Western representative of the American Distributing Co., will shortly take up his duties as a sales representative of the Timken concerns. He will probably operate in Chicago territory.

**DETROIT, MICH.**—A camping car of the prairie schooner type has been built by the Packard Motor Co., for the use of Henry B. Joy, the president of the concern. The car has been designed and built to suit sportsmen who wish to make an extended hunting trip in deserted country and to remain independent of hotels. There is plenty of room for provisions and dogs, besides the regular camping equipment. The body is mounted on a standard Packard 30 chassis.

**SYRACUSE, N. Y.**—L. A. McKay, Western sales manager for the Franklin Automobile Co., is on a business trip through Wisconsin, Minnesota, North Dakota, Montana, Idaho, Utah, Wyoming, Colorado, Nebraska, Alberta and Manitoba.

**ST. LOUIS, MO.**—A. M. Pearson, of Philadelphia, has been appointed manager of the St. Louis branch of the Franklin Automobile Co. Previous to his appointment with the Franklin company he had charge of the truck department of the White Company in Boston and the Packard in Philadelphia.

**CHICAGO, ILL.**—Lafayette Markle, formerly in charge of the Buick interests here, has been appointed general branch manager and supervisor of the E. M. F. Co.'s agencies throughout the United States. He will make his headquarters in Detroit. H. S. Johnston and C. B. Weaver, also of the Buick Co., will travel for the E. M. F. Co.

**DE KALB, ILL.**—Clinton F. Cook, formerly associated with C. B. Broughton in the general garage business, has purchased the interests of C. B. Broughton and will continue the business under the name of the West End Garage. C. B. Broughton will maintain a show and salesroom in the garage and will handle Buick cars in the greater part of De Kalb County.

**DETROIT, MICH.**—A branch of the Sheldon Axle Co. has been opened at 1215 Woodward avenue, the Sheldon company having felt a necessity of a branch in this city to take care of the rapidly increasing commercial vehicle business. C. H. Gleason, David Landau, consulting spring engineer, and W. M. Hogle, formerly with the Alden-Sampson Co., will handle the business.

**SYRACUSE, N. Y.**—The factory force of the H. H. Franklin Manufacturing Co. is being increased as rapidly as skilled mechanics can be obtained, so that during the coming month an increase of several hundred men will be made. The object is to prepare for an increased commercial and taxicab output. A two-ton truck will be added to the line when the essential details in construction have been decided.

**CHICAGO, ILL.**—The business of the Chicago Motor Car Co., Packard agents, has been taken over by the newly organized Packard Motor Car Co. of Chicago. It is located at Twenty-fourth and Michigan avenues, with H. M. Allison, former secretary of the Chicago Motor Co., in charge. The reorganization was made necessary by the accidental death of William L. De La Fontaine, vice-president of the Chicago Motor Car Co.



**C**ONTROL MECHANISM.—A speed-change lever construction.

2. This patent (Fig. 1) relates to the combination of a shaft which may be turned or made to reciprocate by means of a lever, on the outside of which is provided a brake lever having a sleeve oscillating on the shaft mentioned to operate the brake mechanism. The sleeve which surrounds the shaft is provided with an actuating arm and extends beyond the last-mentioned lever. A guide for the levers is adapted to fulcrum the control lever in reciprocating the shaft, and another guide to confine it to any one of several paths of movement in turning the shaft, allowing the lever to oscillate in reciprocating the shaft.

No. 1,002,188—to Horace T. Thomas, assignor to Reo Motor Car Co., Lansing, Mich. Granted August 29, 1911; filed November 8, 1909.

**RESILIENT WHEEL.**—A mechanical wheel in which elasticity is insured by the use of tubular springs.

1. The wheel (Fig. 2) comprises a hub and felloe having apertures, the outer tire-carrying rim being provided on its inner side with a series of cups having central studs or posts. Tubular springs are seated at their outer ends in the cups with the studs entering their bores, while the inner ends of the springs are fitted with centrally apertured cups. Through these and the apertures of the wheel felloe radial bolts extend into the bores of the springs, the bolts being secured by nuts at inner and outer faces of the felloe as well as against the outer face of the apertured cup. The end of the bolts and rim studs or posts are spaced apart and disconnected to allow the springs to yield laterally as well as longitudinally.

No. 1,001,714—to Enos A. Wall, Salt Lake City, Utah. Granted August 29, 1911; filed February 25, 1911.

**REGULATING VALVE.**—A device to regulate the flow of liquids.

4. This valve has a high and a low



pressure chamber with a partition between them and having an opening therethrough. The opening is lined with a different material shaped to form an upper and a lower valve seat between the two chambers. Within the liner a pair of valve members are operatively mounted so as to engage the seats, a second liner of larger diameter being located within the chamber above the opening and a piston mounted in this liner serves to operate the valve members.

No. 1,001,620—to George W. Collin, assignor to the Collin Valve Co., Bridgeport, Conn. Granted August 29, 1911; filed November 18, 1908.

**WELDING OR CUTTING TORCH.**—A burner producing a long, hot flame, using two gases under various pressures for the purpose.

2. The torch includes a chambered head having passages delivering to the chamber thereof from sources of gas supply, a tip with an injector nozzle of reduced area communicating with one of the said passages. The injector nozzle delivers into a mixing channel communicating by means of a duct with the other passages and de-

livering to the mixing channel at a point closely adjacent the point of delivery of the injector nozzle, the tip having another duct also delivering from the last-mentioned passage to the mixing channel at a point removed from the point of delivery of the injector nozzle, which is illustrated in Fig. 4.

No. 1,001,136—to John B. Burdett, assignor to the National Pneumatic Co., Chicago, Ill. Granted August 29, 1911; filed December 24, 1910.

**LIFTING-JACK.**—Worm-gear type of automobile-lifting device.

4. The jack consists of a standard or column containing a lifting rack which engages with a pinion solidly mounted. A worm wheel is rigidly mounted, meshing with the pinion and having a common axis therewith and being driven by means of a worm. A frame which carries pinion, worm wheel and worm is pivoted to the column and adapted to move in one direction in order to bring pinion and rack out of engagement.

No. 1,000,140—to Herbert Austin, Bromsgrove, England; granted August 8, 1911; filed December 5, 1910.

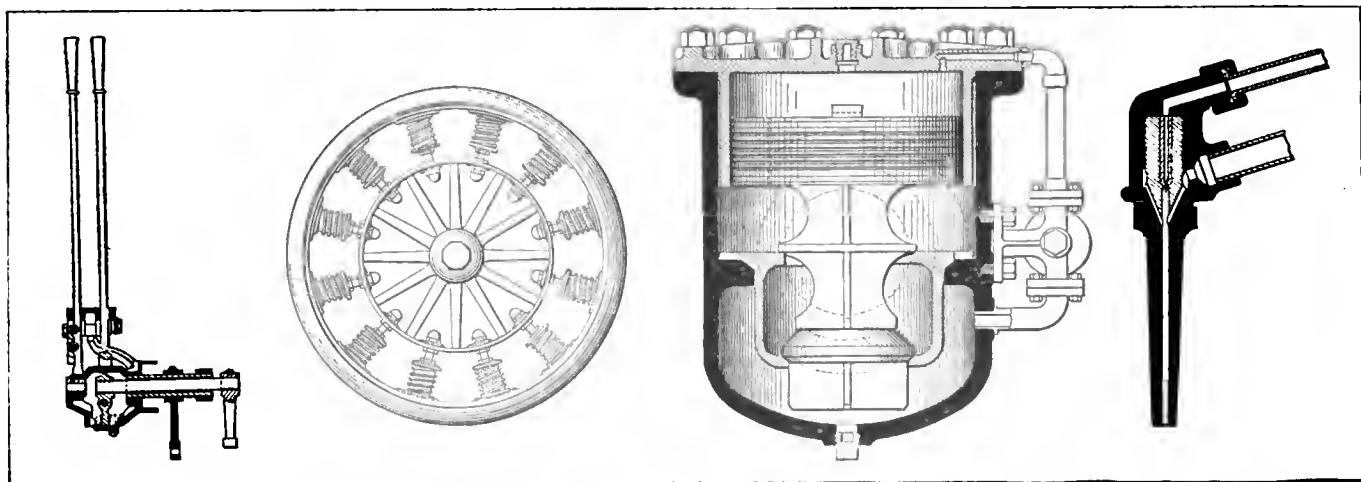

Fig. 1—Thomas control mechanism. Fig. 2—Wall spring wheel. Fig. 3—Collin regulating valve. Fig. 4—Burdett welding torch

# Newest Ideas Among the Accessories

## Cause of Blowouts

THE B. F. Goodrich Co., of Akron, Ohio, has supplied to us the following information in regard to the nature of the most frequent tire trouble, viz., blowouts:

Occasionally a tire will blow out from no apparent cause whatever. The tread seems to be in the best of condition, hardly worn, and yet, without warning, sometimes while standing in a garage, a bad blowout will occur.

The true condition, as shown in the cut, is that the tire has had a hard blow from a large smooth stone while running at high speed. Such a blow may cause the fabric to break seriously on the inside without leaving any mark on the outside. After that, it is only a question of time until the blowout occurs. Sometimes the break will allow a few plies of the fabric to pinch the inner tube, and the tire will deflate gradually.

It is because tire users do not understand such mysterious accidents as this that tires are so often misused, and the resulting breakdown blamed to faulty construction. The series of folders which is now being distributed by the B. F. Goodrich Company will help tire users to increase their mileage by having a better knowledge of the conditions which their tires are having to meet.

## Brown Power Pump

Pure air is pumped into tires inflated by means of the Brown Impulse tire pump (Fig. 2), which is driven by the compression in one cylinder of the motor, a spark plug being removed to allow screwing the end of the pump into the valve cap. The pump is furnished with such interchangeable nipples of A. L. A. M. standard which permit of attaching it to any gasoline

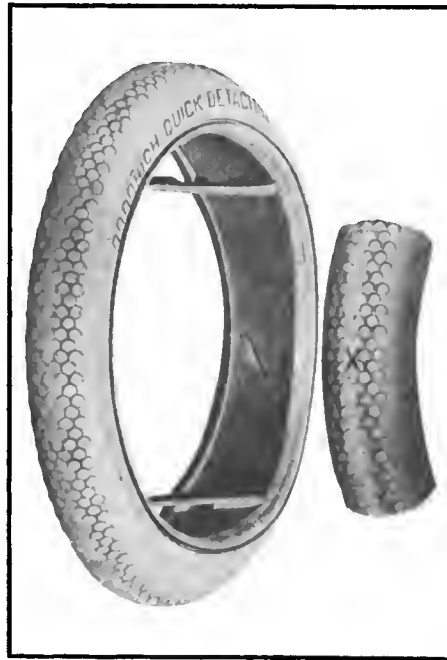

Fig. 1—Showing the tread of a Goodyear tire, as well as portion of it doomed to puncture

motor. The piston in the pump carries lapped iron piston rings. The whole apparatus is of small dimension and weight. It takes from one to four minutes to inflate a tire by the use of this pump, which is the product of the Brown Company, whose factory is located at Syracuse, N. Y.

## Tuto Electric Horn

The Tuto, Fig. 3, is an electric signal with the sound produced by a diaphragm, which is vibrated by an electromagnet. The device is composed of a double coil and armature, a metal rod attached to the latter and a diaphragm located in front of and vibrated through the action of the double coil. The energy needed to pro-

duce the signaling sound is furnished by a set of dry cells, which are brought into play by pressing upon a push button. A slight pressure thereon closes the circuit, the current passing through a resistance. The double coil serves to make and break the circuit, thereby vibrating the diaphragm, which by this motion is made to strike the metallic rod extending toward it from the armature. This produces the sound, which is of a low but clear sort. The horn may also produce a high piercing note. The Dean Electric Co., of Elmira, Ohio, makes this signal.

## Manco Safety Lock

The Manco safety lock is an accessory of manifold use for locking up change-speed lever, magneto and throttle controls, etc. It consists of two jaws (Fig. 4), hinged together. The jaws are capable of moving freely when the cam in the head is not in frictional engagement with its mating member, but when they are brought into engagement and the lock in the head is given a turn by the key, they are locked. The teeth of the two jaws are rounded. The lock will serve well in locking speed-change and emergency-brake levers together, in securing the throttle and ignition levers to the steering wheel or attaching the handle of a suit case to the railing of the car. Since the locking of the device is done on a friction basis of two members, it is possible to use the lock in fastening a coat or like article to a brass railing, thereby closing the lock as tightly as possible on the goods to be secured and then locking the accessory through the office of the key. The form of the teeth prevents their injuring the fabric of the material thus fastened to the car. The M. A. N. Manufacturing Company, of Providence, R. I., is the maker of this lock.

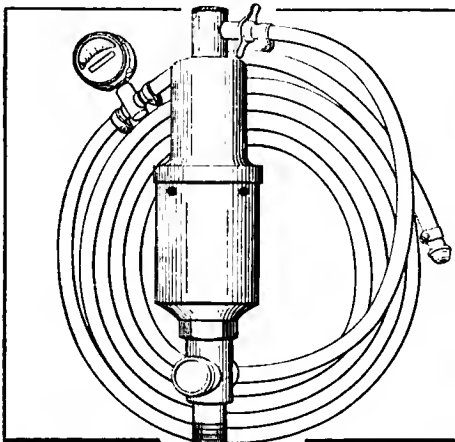

Fig. 2—Brown impulse tire pump

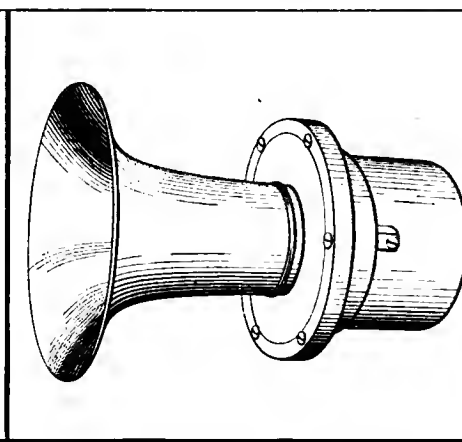

Fig. 3—Tuto electric horn

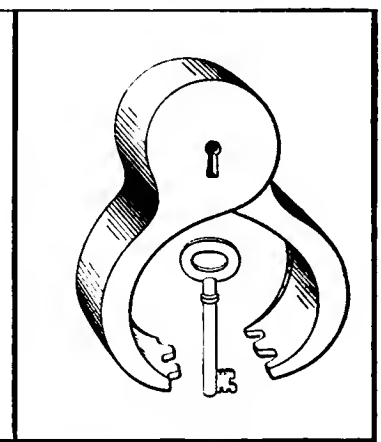

Fig. 4—Manco safety lock

# THE AUTOMOBILE

## Psychology of the Showroom

How Beauty and Harmony of Surroundings Help Sell Cars



1—HOW A MODEL SHOWROOM LENDS ITSELF BY LIGHT, ORDER AND BEAUTY TO THE AUTOMOBILE

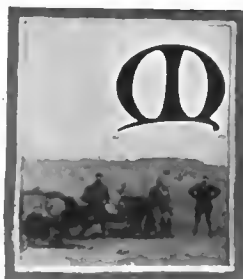

ANY more sales will fall to the lot of the automobile salesman whose wares are displayed in a light, roomy, well-ventilated, artistic, clean and comfortable showroom than can be made by the same man under opposite conditions. Of two men equally equipped and selling cars of the same class, the one that enjoys the better salesroom surroundings will sell more cars.

Psychology plays a most important part in the selling of automobiles. There are scores of different methods in use by salesmen and selling organizations, all of which are based upon the study of the human mind and its operations, with abstract and incidental application. Psychology reduced to its simplest term is the science of human nature and

every salesman is obliged to take it into consideration if he is destined to make any marked success in his side of merchandising.

It has been truly said that there are no two human beings exactly alike and consequently no absolute rule can be laid down to govern salesmen in their relation to customers. In fact the same individual is rarely the same on two successive days and as a result the methods that might be acceptable one day would not answer the purpose at all on the second. But there are some general principles that apply to automobile selling that may be designated as axiomatic or fundamental, and these apply with almost equal force to any other line of salesmanship.

Advertising, under whatever guise it may be presented, lays the foundation for sales. It is the bait that attracts the buyers or possible buyers, and with that phase of the situation this article has nothing to do.

Assuming that an advertising foundation already has been laid



2—Salesroom in the middle of "Gasoline Row," where artistic and utilitarian features spell a big distribution and typical patronage

and that customers have been attracted, the next step is to justify the advertising expense by interesting prospective buyers in the line handled by the company. The personality of individual salesmen is an important point to be considered, previous acquaintanceship with the prospective is another, general reputation of the line is of necessity in the front rank, but quite as necessary as either of these is the setting of the car itself.

The day when it was possible to sell any kind of a car in any kind of surroundings is past. The customers of automobile selling establishments are growing more and more discriminating and the "hoo-row" element has been eliminated to a large extent by automatic selection.

Of course, the business is still in a formative period, but it has progressed sufficiently to take it out of the "game" classification and place it among the great industries.

Therefore, as the business has grown to be keenly competitive the necessity for artistic and effective surroundings for cars

offered for sale has grown to be more and more important until to-day it is regarded as essential.

If a line of well-advertised automobiles is displayed in cramped quarters it may succeed, but it is certain that it cannot obtain the degree of success that it would if it had been shown in the midst of effective surroundings. Just what that means is susceptible of many constructions.

The day of the automobile "store," which was so popular a few years ago, has passed and in present-day practice the store idea has been abandoned. The greatest care is now observed in the arrangement of the showroom so that the line may be displayed to the utmost advantage. There are automobile establishments in New York City that rival anything in their class in the world and there are others that make one wonder how the cars they sell ever managed to obtain any considerable vogue.

On the one hand, there are salesrooms such as several shown herewith that have been built with the single purpose in view of displaying the car, and there are others, as indicated in some of the accompanying pictures, that would appear to handicap sales by reason of crowded conditions and such a multiplicity of models as to distract the attention of prospective buyers.

There are some gorgeous rooms, the interiors of which are like palaces, that seem so supremely attractive as to distract interest from the cars by centering it in the magnificence of the furnishings. Such rooms, of course, are not available for the sale of low or medium-priced cars and but rarely for housing even the highest grades of automobiles.

In New York City there are a number of highly ornate and ornamental rooms devoted to the automobile industry, but the most artistic and expensive of the lot was specially constructed to display its line of automobiles in the same way that the platinum setting of a blazing gem lends itself to



3—Cramped quarters and the dark and crowded store here shown will be exchanged shortly for a magnificent establishment in the same neighborhood



additional lustrousness of the gem itself.

There are other types in which the element of luxury is subordinated and efficiency of display is emphasized. This type probably represents the highest development of the automobile showroom from the general viewpoint of results. There is no limit to price of the cars that may be economically sold amid such surroundings. For instance, one line of medium-priced automobiles recently has been moved into an unusually fine showroom in the heart of "Gasoline Row." The place is big and roomy, well furnished for the comfort of customers and is so arranged as to bring out the artistic lines of the cars in a way that was entirely impossible in the quarters formerly occupied by this concern.

On the other hand, some of the most expensive of the automobiles manufactured in America are handled in large scientifically built structures that are similar in furnishings and equipment in many ways to the quarters of this cheaper car.

It would seem as if the forces engaged in selling automobiles were striving to reach some sort of a standard for salesrooms.

There are a number of successful companies that occupy cramped quarters at present. This is accountable to the fact that they are progressing in size and importance and they have really outgrown their establishments. Several of the illustrations herewith indicate crowded conditions and in each case the company involved has either made arrangements for more commodious rooms or intends to do so in the near future.

One big concern leased what was considered an amply adequate store for its requirements, making the arrangement several years ago when its business in the metropolitan district was small. At that time it was possible to show two models in such a way that access could be had to them from all sides and from various

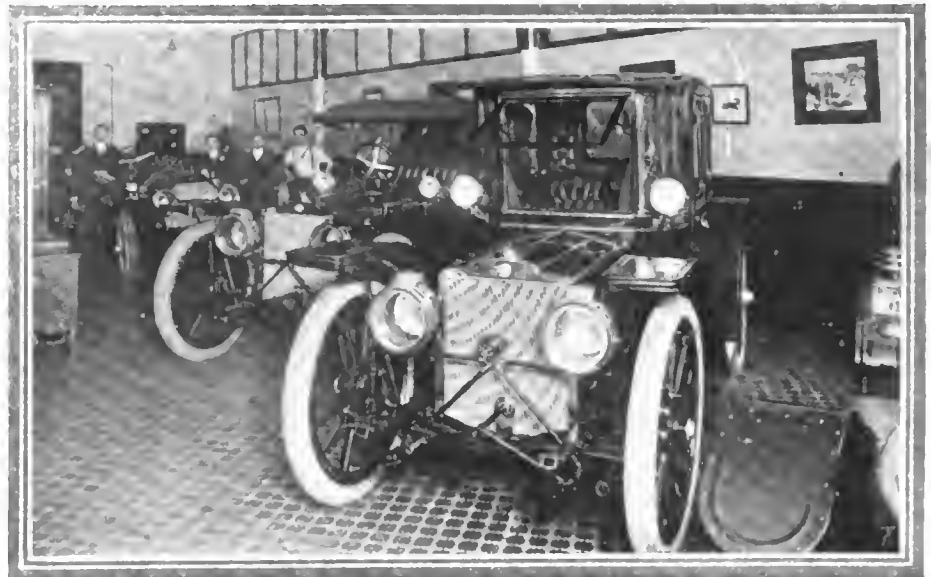

4—Conditions as displayed here have proved so trying to this big concern that it will move to a spacious location where opposite conditions obtain

angles. The price was moderate and the car gave due service. The manager was fortunate in securing good salesmen and the combination proved successful. As business grew it became necessary to show another model and then another and as a result the showroom, ample for two cars, has proved much too small for four or more.

Consequently this company will remove in the near future to quarters nearly ten times as large as those occupied at present and it is safe to say that four cars will be the limit number of those displayed at the same time on the floor.

For quite another reason the quarters of the company shown in another figure seem to be crowded. This concern handles a double line of automobiles and is the eastern distributor for them in a territory that is very wide. Until recently it had quarters facing on a busy corner, but changes in the line of merchandise led to a change in location with the result that undue crowding

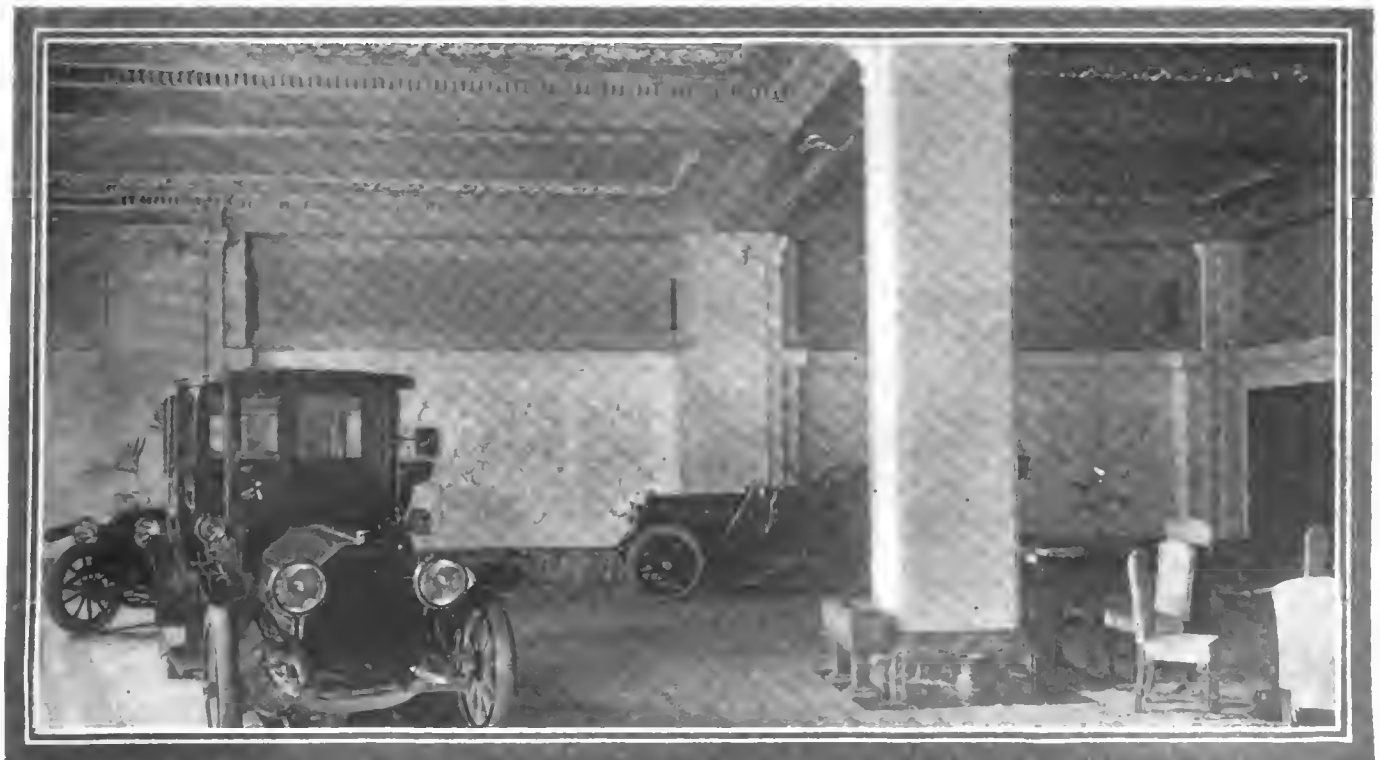

5—One of the most beautiful salesrooms in the world, where luxury and richness blend harmoniously to set off the merchandise





6—How a small room may be used advantageously to emphasize the attractive points of a single model

was experienced. This company will move shortly into a magnificent location further north on Broadway where it will have two floors of 10,000 square feet each, lighted with vast plate glass windows extending from floor to ceiling. In this place the same number of models that crowd the salesroom shown can be displayed in their individual beauty and attractiveness. As it is at present, it would endanger clothes to inspect all the models and by no chance could a proper perspective be reached. The new quarters will change all that.

In a number of the pictures it will be seen that a single car forms the focus of attention. Even where a concern handles a line consisting of a dozen or more models, it has been found advantageous to display only one, according to the aspect of some of these pictures. There is an element of psychology involved in this practice. The automobile salesroom in one sense is a store, inasmuch as the buyer is supposed to go there to purchase from its stock. But the selling of automobiles is somewhat different from selling groceries or cotton goods, because the customer rarely buys the identical car shown on the floor. Of course, he may do so in extraordinary instances, but as a general thing his purchase is made after observing a "sample" car.

Only in unusual cases is the company able to make delivery of a car to its purchaser on the same day the transaction is closed, for the reason that it takes time to get the car out of the warehouse or to have it shipped from the factory. Some of the companies do not promise delivery under thirty days.

For this reason a single attractive model, shown amid surroundings that harmonize with it and make for the comfort of



7—Vast expanse of plate glass and a businesslike showroom is sometimes used to exhibit one automobile with excellent results

the purchaser and the ease of his inspection, is considered better than the display of many models under any other conditions.

One of the most successful sales managers on the "Row" explained how he handled his business, particularly with reference to the assistance lent or obstacles imposed by the arrangement of his salesroom.

"In the first place," said he, "the physical aspect of the showroom in the automobile business is quite as important for the sale of cars as the appearance of a jewelry store or a furrier's establishment in the sale of diamonds, silver fox and sables. No matter what car is handled, its surroundings should be in harmony with it. To my mind it would seem the height of folly to crowd a room full of cars so that inspection would be difficult even in moderate degree. The place must be clean and bright. There is nothing so thoroughly out of place in an automobile salesroom as disorder. The car is a bit of mechanism, representing the last word in the development of transportation and deserves, first of all, to be clean in its surroundings. Second, the matter of light should be considered. If the showroom has a polished floor and the windows extend close to the floor, there will be an added quality to the light that will go a long way toward making sales. Third, there should be an understanding and intelligent arrangement of the interior of the room.

"If the establishment is large enough to handle a number of models, there is room for the display of considerable ingenuity



8—This picture shows the exception that goes to prove the rule, and still if more space and light were used the sales might be even greater

in their arrangement. Six cars backed against the wall with only just room enough to pass between them is not nearly as good as three models so placed that the customer has a chance to see them from all sides and to reach them from both ends.

"It is to be assumed that ventilation, heating and a reasonable degree of artistic merit in the decorations have been provided.

"In a showroom of only medium size which would be sufficient to house possibly eight cars, it is my idea to cut the number in half. I place one of the big cars, equipped with a striking top and attractive coloring, at an angle to the show window. This is to catch the eye of the casual visitor or passer-by to a certain extent, but in the main the object is to create a pleasant impression upon the prospective buyer who visits the establishment seeking an automobile.

"After passing the show window to the front door and seeing the big car nicely displayed, the visitor walks by this model and his interest is taken up with other things. Perhaps the car we have been pushing is one of smaller size and possibly we might have trouble in making prompt delivery of replicas of the big car, at any rate the buyer has a chance to see the first car and gain an impression of size and power from it. I have found it most effective to place the special object of our selling in the middle of the room where its lines will show to advantage and its points will be easily observable.

"I make it a point to have only a little furniture in the room so that nothing can detract from the cars themselves by distracting the attention of the customer. Naturally there must be a few chairs and settees and a little greenery is not amiss, but in my opinion these may be reduced to the minimum.

"The salesman should never meet the customer at the door, it gives a wrong impression of eagerness and has spoiled many a sale. Let him advance toward the caller a little less than half way, thus making the customer take the attitude of the inquirer. With the picture of the big car in his mind it is easier to direct the customer toward the leader of the line which may be of less cost, than it would have been if the positions of the models had been reversed.

"I have seen sales lost through over-eagerness on the part of salesmen, but I recollect no case of the kind that resulted from thoughtfulness in this particular.

"There is no element of misrepresentation in placing a big, expensive car in the most prominent place in the showroom as viewed from the street, even though your advertising campaign has all been directed toward the sale of some other model. Automobile buyers of to-day are not children and in the vast majority of instances I have found that they have a pretty general idea of what they want before they start out to make their purchases.

"After the interest of the customer has been aroused in the car it is time to explain the mechanical features as shown in a



10—A little crowded, but effectively arranged. This room would look better with only two cars on the floor

actual buyers in the best of the shops at 15 per cent. of those who inquire and at the poorest establishments at 8 per cent, it will be seen that there is a vast amount of business that is accountable to good surroundings, or in the converse attitude, lost to some concerns because of opposite conditions.

Now that the automobile is on a strict dollar value basis, it behooves selling concerns to recognize the utility and necessity of conforming to the best practice as regards the setting of their merchandise. Only a few lost sales would represent the actual added money expenditure necessary to convert a "sow's ear into the proverbial silken purse," and on the other hand a few additional sales each season would balance the augmented expenditure.

Under sharply competitive conditions as they obtain now and as they will probably be accentuated in the future, additions to the business of a concern, even when achieved at the expense of a greater investment, must be reckoned as an important element in its life. Consequently the importance of scientific showrooms is of sufficient force to deserve even greater attention than has been given this feature so far in the development of the automobile industry.



9—Ordinarily three models are shown in this room, which is a model in its way, but stocks are low at this time of the year

cut-out chassis. I find that it is not necessary to place the chassis in the most prominent place in the room. Let it be off to one side, because the customer will have to be led to it in any event. In many of the best salesrooms no chassis is provided for ocular demonstration, that part of the sale being accomplished at the garage.

"Another thing that I would call particular attention to is to criticise the rather common practice of displaying used cars in the same place with the current stock. Automobile buyers are a sensitive lot. The bulk of them are business and professional men of wealth and importance in the community and as such they do not wish to throw themselves open to the charge that they are contemplating the purchase of a second-hand car. On the other hand, there are many estimable persons who do wish to buy second-hand cars and they, too, might have some little delicacy about examining the stock of used machines in the same room with their neighbors who may be buying new cars. Thus, there is nothing to gain and everything to lose by showing both varieties in the same room."

The whole matter may be summed up in a few words. From 5 to 30 per cent. of all inquirers for automobiles purchase cars. The percentage is much higher in the fine roomy establishments than it is in those where the cars cannot be displayed to the best advantage. Reckoning the average of

CONCERNING TIRE DURABILITY—The life of a tire, other things being equal, is proportional to the square of the section diameter. The square of 4 is 16 and the square of 3.5 is 12.25. The life of the 4-inch tire from this point of view will be as 16 is to 12.25 comparing it with a 3 1-2-inch tire.



11—One of the most scientifically arranged show rooms in New York, the home of a concern that outgrew its old quarters on upper Broadway

## Fatalities Mar Syracuse Meet

SYRACUSE, N. Y., Sept. 18—A day of splendid motor racing sport, upon what visiting cracks declared is the premier dirt mile track in America, was shadowed to-day by a tragedy in the special 50-mile event which cost eleven lives and the injury of half a score. In the forty-third mile of this race, watched breathlessly by a throng of 75,000 persons that jammed the giant stands and stretched many deep about the fences clear around the track, a front tire on the Knox machine, driven by Lee Oldfield, blew out upon the turn leading into the back stretch, the driver losing control and the car shooting diagonally across the track and into the outer fence, behind which were massed many spectators. The car plunged through the crowd, flinging mangled human forms high in air, and ploughing through a bed of soft cinders, turning over and over and stopping far beyond the scene of impact, a dismantled wreck. When the final toll was taken Saturday, it was found that eight

men and one nine-year-old boy, who was found clinging to his dead father's hand, had been killed and eight others had been injured, some fatally. Two others died on Sunday.

Despite the seriousness of the accident the contest continued, and at its close Ralph De Palma in his Simplex finished without a stop on one flat rim and with the new world's figure of 47:21.65 for 50 miles done on a dirt circular track to his credit. When the first half of the race was done he had negotiated a new 25-mile world's mark of 23:15.15. His division in this merged race was Division B, for cars 300 to 600 cubic inches displacement. In Division A, the Abbott-Detroit, driven by Mortimer Roberts, which plugged through without stopping, was the winner.

After the death-dealing crash occurred the drivers looked toward the officials as the machines came around the home stretch. Apparently the pilots expected the signal to stop. But none was given, and they kept on. It was by a miracle, seemingly, that others were not killed during the remainder of the race, for the track at the scene of the accident was half filled with people. In taking that turn for the remainder of the race, De Palma and the others reduced speed appreciably and threaded their way with wonderful dexterity among the reckless groups that had encroached upon the track.

With the conclusion of this race two more events—the second heat of the Remy Grand Brassard and the 5-mile open class—remained to be run. Starter Wagner lined up the contestants for the second heat of the Brassard event, but there was a menacing growl of dissent from the crowds. After a hurried consultation in the officials' stand the remainder of the program was called off. It was a ghastly finale to the most exciting day of motor racing sport this city has ever seen.

Shortly before the start of the fatal race, President Taft, the guest of honor for the closing day of the New York State Fair and the honorary referee of the automobile events, had been driven in an automobile and with a military escort past the stands.

From the standpoint of racing, the day was a complete success. Earlier in the afternoon Burman broke the track record for a mile, flying start, with the Blitzen Benz, despite a broken piston. When his car began to wobble after the breakdown Burman worked like a Trojan at the wheel and managed to keep the car away from the fence. He lowered the track record of 48:92, made by De Palma in his Fiat here in 1910, by 1-10 second, and had it not been for his mishap, he would undoubtedly have bested the Brighton mark of 48:62, made on Labor Day.

In the event for the Remy Brassard and trophy there lined up De Palma in his "50" Simplex, Burman in a Jenatzy Mercedes and Kilpatrick in his 200-horsepower Hotchkiss. De Palma won the race in 2:54.57, though Burman finished close to him.

In Division 2, Class C, 161 to 230 inches displacement, the Ford, driven by Frank Kulick, and the Abbott-Detroit, Mortimer Roberts, had a stubborn battle that brought the great crowd to its feet. Roberts succeeded in nosing out his opponent by half a car's length, and as he won again in his class in the 50-mile event, with the same car, he was one of the stars of the day.

The most sensational finish of the day was furnished in the 5-mile event for cars with piston displacement from 301 to 450 cubic inches, when Burman, in the Opel, trailed Turner in the Amplex for the entire distance till the last turn into the home-stretch, then sent his car down the stretch like a bullet, just nipping the honors at the wire by a nose.

The event for cars of piston displacement from 231 to 300 cubic inches proved to be a struggle between two speedy Mercers, and Hughie Hughes, out for blood, succeeded in beating De Palma, doing the 5 miles in 4:57.22.

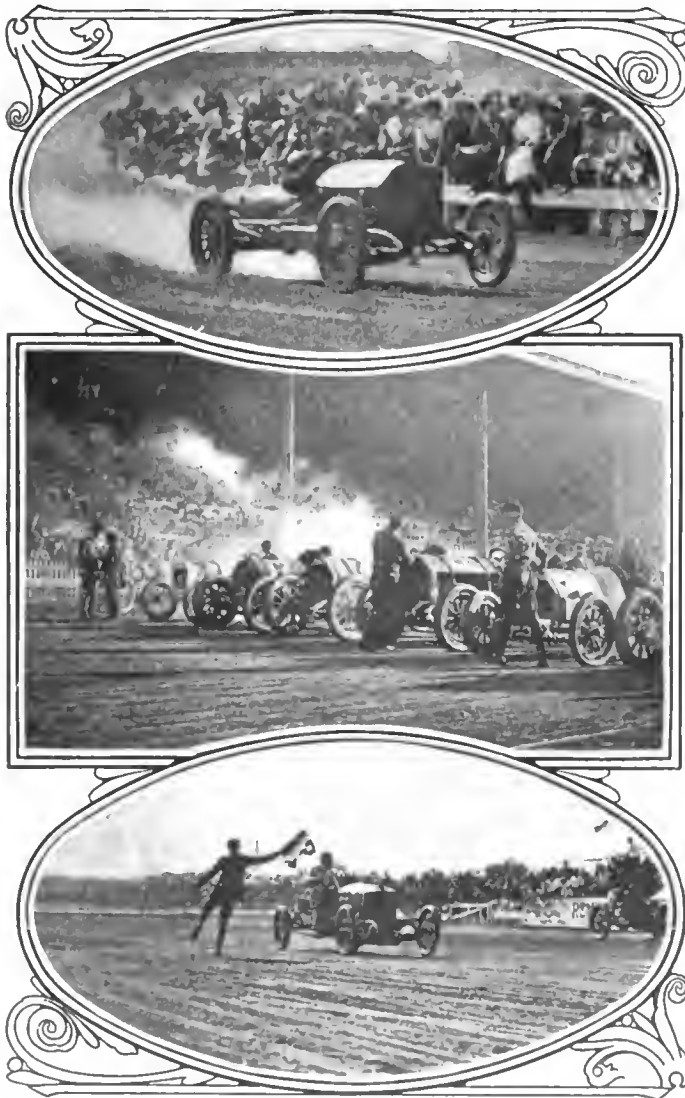

Ralph De Palma in Simplex on last lap of 50-mile race, in which he established new records

Start of 50-mile race, run in two classes simultaneously, Simplex winning in Division B, and Abbott-Detroit in Division A

Close finish in the 301 to 450 race between Burman in an Opel and Turner driving an Amplex

In the seventh event, for cars 600 inches in displacement and less, with a minimum weight of 2,100 pounds, De Palma scored his first victory of the afternoon. Besides his Simplex and Burman's Opel, the other starters were the Amplex, driven by Bill Turner; the Knox, Fred Belcher, and the Cino, John Raimey. Belcher stalled his engine at the pistol's crack and was out of it without moving. At the end of the first mile Burman dropped out because of tire trouble. The Cino car retired during the next mile for a similar reason. At the end of the fourth mile the Simplex had a quarter-mile lead over the Amplex, the only other car left in the race. De Palma completed the tenth mile a half-mile in the lead in 9:39.56.

Just previous to the Remy Brassard event the Presidential party and escort passed around the track, preceded by a "water-wagon." Someone, in the desire to avoid the inhalation of dust into the Taft lungs, had given orders for a sprinkling cart to precede the parade. The entire homestretch was soaked and slippery and the starters for the Remy Brassard properly refused to endanger their own necks and those of the crowd till the track should dry. So there was an hour's delay, while everyone watched the aviator's flights and the balloon ascension.

When the race was finally started three cars leaped away in a flying start for the three-mile flight. Burman drove the Mercedes car which Lee Oldfield had been scheduled to drive. De Palma was at the wheel of his Simplex and Kilpatrick guided a Hotchkiss. The race was all between De Palma and Burman, though the Italian was never headed. The Mercedes came up to close quarters several times, but the Simplex leaped away, and in the final rush it captured first honors by 200 feet in 2:24.57.

There was another delay before the 50-mile race was under way. A big field from the combined divisions faced the starter, including Burman's Opel, De Palma's Simplex, Oldfield's Knox and Turner's Amplex in Division B, while in Division A there were Hughes, Roberts, Morton and Raimey driving, respectively, a Mercer, Abbott-Detroit, Kline Kar and Cino. At the start of this ill-starred event the Simplex, next the rail, leaped away in the lead, and when the tangle had unsnarled the Opel was found in second place, close to its rival's wheel. Third was the little Kline Kar. The crowd in the stand cheered frantically as the cars came around the first time, and at the end of the second mile the order was unchanged. With the third mile, however, Burman had dropped back to third place, and soon afterward had to quit because of engine trouble.

De Palma's car continued to sweep around in splendid style, continually increasing its lead. The Knox grabbed second place for several miles, when Turner's Amplex headed it. And, by the way, in the programme Fred Belcher was scheduled to drive the Knox, and Oldfield was substituted without any announcement to that effect being made from the official's stand. This Knox car was sent here for the races from Springfield, Mass., the home of the Knox Automobile Company. It is the car which Belcher drove in the 500-mile Indianapolis race. Belcher drove it here from Springfield and it was then turned over to Lee Oldfield.

While the higher-powered cars were struggling, the sturdy little Abbott-Detroit kept plugging on. Other cars in its class ahead of it had to stop frequently to replace tires and the final result was that, without having to halt for any accident, it won.

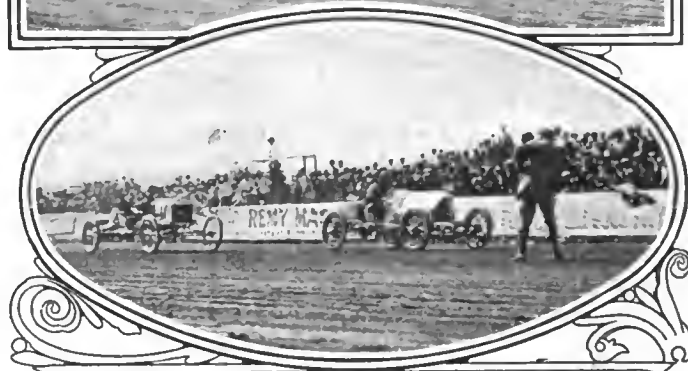
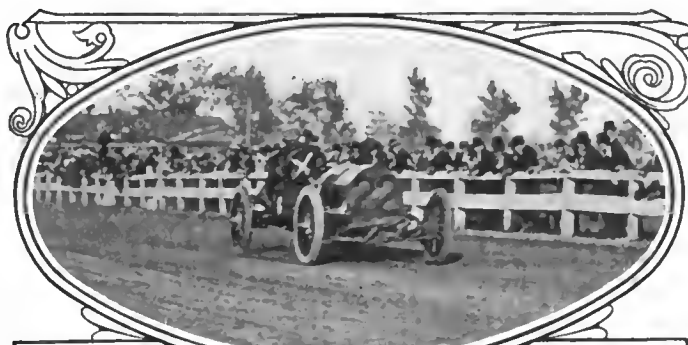

Mercer No. 22, driven by Hughie Hughes, which captured first place in the race for cars of 231 to 300 cubic inches

Line-up for the start of the Remy Brassard, won by Simplex, De Palma, from the Benz and Mercedes

Abbott-Detroit, driven by Mortimer Roberts, winning the race for cars of 161 to 230 cubic inches

The race had drawn well toward its finish, and De Palma had long since annexed a new world's record for 25 miles, when the Knox and Amplex, which had been in close rivalry, tacked into the car of the flying De Palma, Oldfield in the lead. De Palma was then just a lap ahead of them. For circuit after circuit the race continued. Suddenly, in coming down the homestretch, a yell broke from the crowd. There was a loud report and the tread of one of De Palma's tires flew high in the air. He kept on and the rubber was immediately ripped in pieces by the crowd for souvenirs. On the second lap thereafter the accident occurred.

SUMMARY OF THE EVENTS HELD IN CONNECTION WITH THE STATE FAIR AT SYRACUSE, N. Y.

Pos.	Car.	Driver.	Time.	Pos.	Car.	Driver.	Time.
161 to 230 Cubic Inches, Five Miles							
1	Abbott-Detroit	Mortimer Roberts	5:05.79	Remy Grand Brassard Race, First Heat, Three Miles			
2	Ford	Frank Kulick		1	Simplex	Turner	2:54.57
231 to 300 Cubic Inches, Five Miles							
1	Mercer	Hughie Hughes	4:57.32	2	Mercedes	Burman	
2	Mercer	Ralph De Palma		Hotchkiss also started. (Second heat declared off, after accident.)			
301 to 450 Cubic Inches, Five Miles							
1	Opel	Burman	5:01.34	Special Race, Fifty Miles (Two Classes Simultaneously)			
2	Amplex	Turner		Division A, Cars Under 300 Cubic Inches			
Record Trial to Beat Track Record (48.92)							
	Blitzen Benz	Burman	48.82	1	Abbott-Detroit	Mortimer Roberts	
600 Cubic Inches and Less, Ten Miles							
1	Simplex	De Palma	9:38.56	2	Mercer	Hughie Hughes	
2	Amplex	Turner		Kline Kar and Cino also started.			
Opel, Knox and Cino also started.							
Division B, Cars 300 to 600 Cubic Inches							
	Opel, Knox and Amplex also started.			1	Simplex	Ralph De Palma	47:21.65





Durable Dayton, No. 27, being given the word by the starter



The Mais entry, No. 24, in Division 7-K, 4,001 to 5,000 pounds



Lauth-Juergens, No. 17, about to start away on the four-day journey



The Saurer representative in the big division, 10,001 to 15,000 pounds

# 32 Vehicles Start in

CHICAGO, Sept. 18—The first commercial motor vehicle test run under the system evolved by the rules committee of the Manufacturers' Contest Association, which makes the affair a demonstration instead of a contest, is now on, with the Chicago Motor Club acting as master of ceremonies. Complying with the wishes of the truck makers, the event is designed to show the business world just how the power vehicles operate in business service. The three routes chosen are mostly in the city or include adjoining towns which really seem to be parts of Chicago; the trucks carry their catalogued loads in the shape of sand; they are allowed ample time in which to make the trips and the penalizations are imposed only for replacements, taking on supplies outside of controls, for lateness and for damaged or lost parts as shown in the examination at the end of the test.

The routes selected for the affair aim to take in the entire commercial and manufacturing districts of Chicago and adjacent suburban cities. To-day the trucks went to Hammond by way of Whiting; to-morrow they run north to Evanston in the morning, stop at noon at the stock yards to allow the packers to inspect the cars and in the afternoon go to Oak Park and return; Wednesday the journey is a trifle more strenuous, being to Chicago Heights and return. The running schedules vary from 5 to 11 miles an hour, according to class.

As a means of comparison, the club has arranged to send out a two-horse truck carrying two tons of sand to-morrow, with Chicago Heights as its turning point. It is calculated that it will take at least two days for the horses to make the round trip, which will make them finish at the same time as the motor trucks, which, however, do not go to Chicago Heights until Wednesday.

In the entry line the club has made a record. In the first place it secured thirty-two nominations representing twenty-three concerns, which is a bigger entry list than the Chicago-Detroit run had and at five times the entry fee; in the second place every truck nominated started this morning from the White garage at Wabash avenue and Twenty-sixth street.

The first day's run eliminated only three of the perfect scores, one of them being a withdrawal, another a minor penalty for taking on oil and the third a big demerit which probably will put the car out of the running for a prize. The Swanson was the

### ROSTER OF STARTERS IN CHICAGO TRUCK RUN

Division 2-K, 501-1000 Pounds						
No.	Car.	Driver.	Weight Full.	Weight Empty.	Weight Load.	First Day.
1	Mercury	Alkofer	2850	1810	1040	Perfect
2	Mercury	Lott	2890	1840	1050	Perfect
Division 3-K, 1001-1500 Pounds						
3	Clark	Odin	4770	3175	1595	Perfect
4	Buick	Easterday	4460	2680	1780	Perfect
5	Sampson	Krankey	4365	2860	1505	Perfect
6	McIntyre	Thomas	4225	2830	1395	Perfect
7	Crown	Hollnagel	4335	2680	1655	Perfect
8	Krickworth	Worth	4425	2710	1715	Perfect
Division 4-K, 1501-2000 Pounds						
9	Clark	McCue	5500	3400	2100	Perfect
11	LeMoon	LeMoon	5480	3400	2080	Perfect
10	Clark	Wallwork	5640	3520	2120	Perfect
12	Little Giant	Aplin	4860	2780	2080	Perfect
14	Adams	McLean	5860	3785	2075	Perfect
15	Swanson	Severin	4925	2840	2085	Out
16	Lauth-Juergens	Juergens	5620	3500	2120	Perfect
17	Lauth-Juergens	Herrick	5430	3330	2100	Perfect
18	Decatur	Mattoon	5990	3940	2050	Perfect
19	Monitor	Barnikow	5010	2940	2070	668
20	Chase	Mraz	4700	2630		Perfect
Division 5-K, 2001-3000 Pounds						
21	McIntyre	Smith	6720	3675	3045	Perfect



# Chicago Truck Run

one to pull out, its withdrawal being caused by a skid which broke a radius rod on the run home this afternoon. The Monitor first had clutch trouble, then rear axle trouble, which brought 338 points penalty, to which was added 300 more for being late at the night control. The veteran Reliance, known as old Adam and which is declared to be the oldest truck in Chicago from a service standpoint, having been running for a local brewery for 5 years, had to take on oil, for which it was assessed 3 points. The oiler on old Adam is a small one, fitted years ago when no one expected the trucks to do their 60 and 70 miles a day.

The run to Hammond and back to-day was more of a strenuous test than had been anticipated when the route was laid out. Ordinarily the trip would have been an easy one but Sunday night Chicago was deluged by a downpour of rain that "raised Cain" with the country roads. Of course the trucks could not run on the boulevards and to add to the trouble it was forbidden to strew confetti inside the city limits, which made the drivers go carefully in order to avoid losing the course. On top of this the contestants on their way back found a big gang of workmen tearing up the street car tracks at South Chicago avenue and Stony Island avenue, where the road is not too good anyway. This caused a congestion that looked serious for a time, but eventually the tangle was straightened out and everyone got through.

The noon stop at Hammond found every truck there on time. The 1-ton Decatur, pneumatic shod and carrying a ton of sand, made a remarkably quick run of it, covering the 20 miles in 1 hour and 18 minutes. It was demonstrated, however, that a pace of 11 miles an hour is a trifle too fast for the lighter vehicles over such roads while the big fellows are not asked to go fast enough on a 5-mile an hour rating.

It is interesting to note that the thirty-two vehicles carried in all 61 tons of sand which shows that the average load capacity of this representative field runs close to 2 tons per car—a very high average indeed.

## Six Penalized the First Day

CHICAGO, ILL., Sept. 19—The second day of the commercial motor vehicle demonstration saw five penalizations and of this number two withdrew—No. 32 Alco and No. 21 McIntyre. The former burned out a bearing, while the latter hit a beer wagon,



McIntyre, No. 21, only starter in 2,001 to 3,000-pound class



Clark No. 10, Wallwork, driver, one of a pair in 1,501 to 2,000-pound class



Stegeman, No. 30, which started in the 7,001 to 10,000-pound class



Sampson and Buick, two starters in 1,001 to 1,500-pound division

### ROSTER OF STARTERS IN CHICAGO TRUCK RUN

Division 6-K, 3001-4000 Pounds						
No.	Car.	Driver.	Weight Full.	Weight Empty.	Weight Load.	First Day.
22	Stegeman	Stegeman	9320	5050	4270	Perfect
23	Reliance	Carney	9975	5830	4145	3
Division 7-K, 4001-5000 Pounds						
24	Mais	Davies	11835	6720	5115	Perfect
Division 8-K, 5001-7000 Pounds						
25	Alco	O'Mara	15900	8745	7155	Perfect
26	Old Reliable	Kline	15165	7975	7190	Perfect
27	Durable Dayton	Haines	13510	7450	6060	Perfect
28	Pope-Hartford	Russell	13440	7330	6110	Perfect
Division 9-K, 7001-10,000 Pounds						
29	Saurer	Atwell	15930	6790	9140	Perfect
30	Stegeman	Stegeman	16340	8215	8125	Perfect
31	Sampson	Shires	20900	10800	10100	Perfect
32	Alco	Rooney	20430	10370	10160	Perfect
Division 10-K, 10,001-15,000 Pounds						
33	Saurer	Berger	21525	8380	13145	Perfect



Pope-Hartford, No. 28, which will strive for the honors in Division 8K

demolishing the steering gear. Besides this, No. 2 Mercury, was penalized 72 points for coil trouble; No. 14 Adams, 6 points for taking on oil outside of control, and No. 23, Reliance, which was penalized yesterday 316 points for replacing a bearing. No. 19 Monitor, heavily penalized yesterday, did not start to-day.

The run to-day was to Evanston in the morning, returning for the noon stop at the stockyards, where the trucks were held an hour and a half in order that they might be inspected by the packers, while in the afternoon they went to Oak Park and back, making a day's journey of 61 miles. The stockyards stop was a happy idea, for great interest in the trucks was shown by the packers, and it is expected that considerable business will result.

The horse-drawn truck, loaded with two tons of sand, made its getaway this morning and to-night is at Homewood, 20 miles out.

No one wanted No. 13, so it was given to the horse rig, which is expected to finish to-morrow afternoon, using two days for a journey the truck will make in one.

With two-thirds of the run over there are two-thirds of the contestants left with perfect scores. It looks as if there will be at least 20 clean to-morrow night. Thursday morning there will be a mild sort of a final examination, in which only the steering gears, brakes and transmissions of the contesting vehicles will be examined.

### Good Roads Congress in Chicago

CHICAGO, Sept. 21—The fourth annual international good roads congress and exposition opened in Chicago yesterday for a lengthy run, with representative men from all sections of the country in attendance. The congress is being held at the La Salle Hotel, and will continue to October 1. Governors of many States have promised to attend and it is hoped to have one of them preside each day of the congress. Arthur C. Jackson is president of the congress, and among the weighty propositions he has mapped out for discussion are the Jackson memorial highway, a national turnpike from Los Angeles to New York, and the proposed Lincoln memorial highway. The congress also is expected to strongly advocate the employment of convict labor on the roads.

### Chapin Named as Good Roads Delegate

DETROIT, Sept. 18—Roy D. Chapin, of the Hudson Motor Car Company, is one of the five Detroit men named by Governor Osborn to represent Michigan at the Fourth International Good Roads Congress, to be held in Chicago September 18 to October 1. The others are: Edwin S. George, Horatio E. Earle, father of the good roads movement in Michigan; Ben Otto and H. S. Nimmo.

## Chalmers Owners Tie

DENVER, Sept. 18—The second annual Chalmers Owners' Consistency Tour, run on Thursday and Friday last, from Denver to Estes Park and return, resulted in a tie between Allen DeBerry Bowen, driving car No. 3, and Dr. Edward Lazelle, driving car No. 18. The result was in doubt throughout the entire race. Twenty-four cars entered the event, and, although all were driven by amateurs, there was not a single instance of mechanical trouble in the entire distance of 200 miles, and the tire troubles were confined to the one car driven by E. B. Field, Jr. Within the coming week the two leading cars will decide the tie by a run to Colorado Springs and return, and it is expected that a number of other auto enthusiasts will act as escorts.

Messrs. Bowen and Lazelle had only two points charged



Alco pair, both of which finished with a perfect score on first day

against them, and the third car, driven by F. C. Dreher, was charged with only three points. The showing is remarkable inasmuch as the drivers were comparatively unskilled in tour driving and that there were nine secret controls along the road, a penalty of two points being made against any car passing the control either two minutes behind or ahead of schedule.

The twenty-four competing cars left the starting point at 8:30 Thursday morning. They were started off one minute apart, the schedule being so arranged that the average speed of the first car was 17 miles an hour, the second 18 miles, the third 19 miles, the fourth 17 miles, and so on.

### Fairmount Park Race Comes Next

Eight entries have been received so far for the Fairmount Park road race, the classic automobile event staged each Fall at the Quaker City. The event is scheduled for October 7 and in the past has always developed a picturesque contest. The entry list is limited to thirty cars and the experience of the past has been that the bulk of them come in late. Usually the list grows to about ten until a week from the date of the race when the box is swamped.

The race is to be held under the auspices of the Quaker City Motor Club and will be run in Class C, Divisions 3C, 4C, 5C and 6C. The entry fee is \$500 and the winner in each division will get \$1,000. The grand prize for the fastest time will be \$2,500 in addition to the class prize that goes with it. The distance of the race will be 25 laps of an 8-mile course laid out on the west side of the park. The police arrangements this year will be practically the same as they were last, when nearly 2,000 men guarded the course.

F. E. Edwards, chairman of the Technical Committee, will be in charge of the examination of the cars. Fred C. Dunlap will act as referee and Fred J. Wagner will line up and start the contestants.

## Ford Wins Omaha Run

OMAHA, NEB., Sept. 18—A Ford car won the third annual *World-Herald* automobile run, under the auspices of the Omaha Motor Club. A Marion was second.

The Ford was entered and driven by Max Gottberg of Columbus, and the Marion was entered by the Marion Auto Company of Omaha. The prizes were \$250 and \$150, given by the *World-Herald*.

The four-day run, Sept. 12-15, was from Omaha to North Platte and return, a total of 666 miles.

The scores of the cars follow:

No.	Car.	Technical Score.	Road Score.	Total.
5.	Ford	13	1	14
12	Marion	33	perfect	33
6	Velie	35	3	38
1	Lexington	25	17	42
27	Paige-Detroit	50	perfect	50
10	Maxwell	54	perfect	54
3	Ford	37	22	59
14	Alco	98	perfect	98
7	Chalmers	195	perfect	195
9	Case	139	57	196
4	Lion	192	17	209
16	Paige-Detroit	115	138	253

No. 8, a two-ton Kelly truck entered by Andrew Murphy & Son, made the complete trip in but little longer time than the touring cars, and with perfect road score.

Velie No. 6, which was penalized 35 points as a result of the technical examination, had but three demerits on the road.

Ford No. 2, entered and driven by Ed. Brown, sustained a cracked steering housing near Lincoln, but arrived in Omaha ahead of scheduled time. Aside from this it had few points against it, but was withdrawn from the contest. The other cars in the run were the Inter-State pilot car, the Inter-State official car, Hupmobile and Ford press cars.



Old Reliable, No. 26, prominent contender in 5,001 to 7,000 pound division

## Seeks to Enjoin R. C. Hupp

DETROIT, MICH., Sept. 19—Following close upon the retirement of R. C. Hupp from the Hupp Motor Car Company, of Detroit, a bill of complaint was filed to-day by that company in the Wayne County (Mich.) Circuit Court, asking for a permanent injunction restraining Hupp and others associated with him in a new company called the Hupp Corporation from using the name "Hupp" in connection with the manufacture and sale of gasoline automobiles, or in any other manner that would injure the business of the Hupp Motor Car Company; and especially in connection with the manufacture of a small car which, according to announcement, is to be placed on the market by the Hupp Corporation.

The bill alleges that R. C. Hupp and brother, together with the Hupp Corporation, have violated the rights of the Hupp Motor Car Company by the use of the name "Hupp" in the automobile business, inasmuch as the Hupp Motor Car Company used that name at the request of Mr. Hupp when the company

was incorporated, and has made the name well known to the trade and to the public in general; that the use of the name "Hupp" by Mr. Hupp in the new company, the Hupp Corporation, has been, and will be, a source of confusion and embarrassment to the Hupp Motor Car Company and its dealers, to manufacturers and the general public with whom it does business; and that such use of the name "Hupp" as already made on the part of Mr. Hupp and his associates in the company called the Hupp Corporation is an attempt to trade illegally upon and benefit by the reputation and standing of the Hupp Motor Car Company.

## Moline Factory to Be Doubled in Size

MOLINE, ILL., Sept. 18—Contracts providing for the erection of three buildings have been let by the Root & Van Dervoort Engineering Company, a subsidiary concern of the Moline Automobile Company. This will double the output of the plant. Work on the new buildings has already been commenced. The company is far behind on orders, due to inadequate facilities and expansion was absolutely necessary. The new buildings are:

Assembling building, brick construction, one story high, lantern roof, block floor, ground dimensions 85 x 258.

Testing and painting building, ground dimensions 70 x 375, one story basement and floor of concrete construction, lantern roof.

Casting storage building, ground dimensions 70 x 80 feet, one story. After the new buildings are completed assembling work will be carried on in the new building for that purpose instead of the machine shop as is now the case. A large amount of new machinery has been ordered.

## New Officials for Mais Company

INDIANAPOLIS, IND., Sept. 18—At a recent meeting of the stockholders of the Mais Motor Truck Company, H. W. Moore was appointed assistant treasurer. The directors appointed for the ensuing year are: John Saulter, Dr. A. E. Sterne, A. W. Markham, C. L. Chandler, W. H. Roberts and Albert Mais. President Brown contemplates establishing a school for drivers at the factory in the near future.

## Promoters Must Protect Public

While no definite announcement of a change in sanctioning contests on dirt tracks has been made by the Contest Board, it is pretty generally understood that it will be exceedingly difficult to gain official recognition for such race meetings in the future.

For the events already sanctioned to be held on dirt tracks, the Contest Board is insisting that due precautions be taken to prevent any recurrence of such disasters as befell at Syracuse last week.



The Saurer and the Stegeman entries in the 7,001 to 10,000 pound class



Showing the caravan leaving Pittsfield for Lenox on the first day

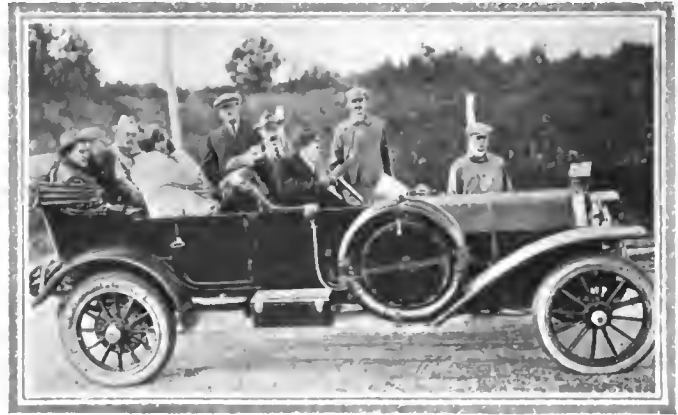

New York Commission, Director Page and Col. Sohier at top of Jacob's Ladder

## Highway Experts Inspect Roads

REPRESENTATIVES of the road departments of New York, Massachusetts, Connecticut, New Hampshire, Washington and of the United States completed on Tuesday a three-day inspection of New York and New England road construction, under the auspices of the Touring Club of America. The party started from Albany Sunday morning and proceeded to Pittsfield and then to Springfield, Mass. On Monday they circled around Springfield and then went south to Hartford and Old Saybrook, finishing the day's run at Waterbury. On Tuesday local inspections were made and the tour was concluded.

Banquets and informal discussions on practical, theoretical and actual road-building were held at Springfield, where the party was entertained at the magnificent New Kimball, and at Waterbury, where the road commissioners stayed at the Elton.

The purpose of the tour was not the interchange of ideas between the road authorities so much as bringing into personal contact the men who have charge of road improvements. A most astonishing condition was developed at the banquet held at Springfield, where, under the direction of Dr. Logan Waller Page, Director of the office of Public Roads of the Department of Agriculture, all the road commissioners and experts outlined present and past practice in their art and told of experiments and their result. Each speaker in taking the floor specifically denied that he had discovered the ideal road from the viewpoint of the user and stated that there was an element of doubt as to the utility of any of the various practices in use to-day.

Commissioner Kemp, of Massachusetts, made a characteristic speech in which, after stating that he knew little of road building, he went on to give a detailed account of some of the Massachusetts roads in which he, as a member of the commission, has direct supervision. Mr. Kemp described the highway followed by the party from the New York State line, taking it mile by mile, and told how eight different types of roads were included in this short route. He said that each mile presented its own problem and that the same type of construction, used by the same volume of traffic, often produced widely different results, while different methods of road building always resulted in some variance of service, durability and maintenance cost.

He said that his State took little pride in the new road which has been constructed around "Jacob's Ladder," but indicated that the time is not far off when road-building will assume a more settled attitude. This, he said, was shown by the offer of one of the Massachusetts division engineers, who agreed to take the contract for maintaining the roads in his district and give a bond to insure this service for less than \$400 per mile, per year. As a condition, this engineer required that the roads should be properly built and crowned and treated with a blanket preparation of oil and fine stone.

Mr. Kemp drew the unavoidable conclusion from his observations that automobile traffic does not wear out the roads with anything like the speed and certainty that follows horse traffic. He pointed out that on several stretches of highway where the crown was in the proportion of 3-4 of an inch to the foot, or more, so that the road was not usable for horse-drawn traffic,



The party leaving Hotel Kimball, Springfield, Mass., on Tuesday morning



Inspecting a new-laid road en route to Springfield, Mass.





Commissioners at luncheon stop in front of the Wendell, Pittsfield

it stood up for years under the automobile travel, while other roads where the crown was not so pronounced, disintegrated, ravelled and were destroyed by the combined traffic.

Dr. Page presided over the session, which was addressed by Mayor Lathrop, Commissioners Sohier, Catlin, Hill, President Whiteside of the Stevens-Duryea company and numerous others of the tourists and local enthusiasts.

On Sunday the tour started from the Hotel Ten Eyck, Albany. Noon control was at the Wendell House, Pittsfield, Mass. On Monday the investigations were so prolonged in Massachusetts that the mid-day stop scheduled for Old Saybrook did not take place until late in the afternoon.

A fine banquet attended by about forty, was held at the Hotel Elton at Waterbury, at which Road Commissioner MacDonald, of Connecticut, made an interesting speech with regard to his sixteen years as a conservator and builder of roads.

The tour was a remarkable success in every way, the members making a careful study of road conditions, but best of all becoming acquainted with one another so that in future there will be more exchanging of views and data, to the profit of motor-dom.

Great praise was extended to the Touring Club of America for its enterprise in bringing the road experts together and for its care in arranging the details of the trip.

The following took part in the tour: Logan Waller Page, Paul D. Sargent, United States Government; William H. Catlin, New York State Superintendent of Highways; John A. Bensele, State Engineer; Charles E. Treman, State Supt. Public Works; Gordon Reel, Highway Department; A. H. Rennie, T. C. A.; J. D. Barnhill, Treasurer T. C. A.; Henry MacNair, Blue Book; F. H. Elliott, Secretary T. C. A.

Massachusetts: Highway Commission: Harold Parker, William D. Sohier, Frank D. Kemp; L. J. Minahan, T. C. A.; William M. Kimball, T. C. A.; John A. Coulthurst, vice-president T. C. A.; Mayor E. H. Lathrop, William H. Whiteside, presi-



Showing an ideal wide macadam driveway in the Berkshires

dent Stevens-Duryea; H. C. Tenney, T. C. A.; W. M. Stevenson, T. C. A.; Albert E. Lerche, President Automobile Club of Springfield; H. A. Brooks, T. C. A.; C. P. Pierce, Arthur Adams.

Connecticut: State Highway Commission: James H. MacDonald, Almon C. Judd, President New England Hotelmen's Association.

New Hampshire: State Engineer, H. C. Hill.

Washington: L. J. Hewes.

### City Sued for Oiling Streets

WALTHAM, MASS., Sept. 16—The question of whether a city or town has the right to oil its streets instead of watering them will be settled by the Massachusetts courts in the future as a result of a suit filed against Waltham on behalf of Mrs. Henry Endicott, of Boston. She was being driven through Waltham some time ago when her motor car skidded and she and her two children, her mother and the chauffeur were thrown out when the car struck a pole.

The contention is to be raised that the street had just been oiled, and that too much oil had been used, thereby making the roadway slippery and dangerous, and that through no fault of the driver the accident happened, but that the surplus of oil constituted a defect in the highway. The progress of the suit will be watched with interest by good roads advocates.

The accident happened at a curve and it is claimed that the motor car was running slowly, but it skidded so sharply it got beyond control of the chauffeur. All the occupants were injured, Mrs. Endicott sustaining a broken knee cap, her mother, Mrs. Francis P. Sears, was cut on the head and the children were bruised and unnerved. The car was badly damaged, too. The family is one of the most prominent in Boston society and so the case will be pushed.



Resurfacing old roadway with a coat of tar oil and stone screenings



The party leaving Stockbridge on the road to Lee, Mass.



## Trade Is Booming at Detroit

**D**ETROIT, MICH., Sept. 18—With the Studebaker Corporation adding another plant, to be known as No. 10, to its Detroit industrial group, with work well under way on the Continental Motor Manufacturing Company's extensive new factory out in the Fairview district, and with plans either completed or nearing completion for at least two more mammoth automobile plants in the north end, the local outlook for the immediate future of the industry is anything but discouraging.

The big event of the week in local motor circles was the purchase by the Studebaker Corporation, through Walter E. Flanders, general manager of the Detroit factories, of the Ford Motor Company's old plant on Piquette avenue, directly east of the No. 1 plant of the E-M-F division. This gives the Studebaker interests two square blocks in this vicinity and adds greatly to their facilities. The plant had been practically deserted for some time, the Ford Motor Company having abandoned it as an auxiliary factory. New machinery will be installed at once and the factory put in operation as soon as possible with a force of 1,000 men. As already indicated, it will be known as E-M-F plant No. 10.

With regard to the purchase, Mr. Flanders said: "Our only purpose in acquiring the old Ford plant is to facilitate the extensions of our business. We propose to build 50,000 cars for the 1912 season. Of these 30,000 will be the Flanders "20" and 20,000 the E-M-F "30." One of the main purposes in bringing our dealers from all over the country to Detroit is to show them that we are going ahead just as fast as we can in the work of increasing our facilities. Within 60 days we will be manufacturing 250 cars a day."

Ground was broken last week for the Herreshoff Motor Company's new factory on Woodward avenue, between Belmont and Trowbridge avenues, the site occupying an entire square. The property immediately adjoins Boston Boulevard, one of the most exclusive residence streets in the city.

The company aims to make the new plant, because of its prominent location, as attractive as possible, a model in fact. The separate administration building, fronting on Woodward avenue, will be of red brick and cement, with ornamental tiling in front and sides. The interior will be finished in white enamel and mahogany. This building will contain, besides the offices, spacious showrooms and a reception room for out-of-town customers. The factory will conform to the administration building in exterior appearance. The power plant will be separate from the rest of the institution and will be located in the furthest corner of the lot.

W. C. Durant, formerly head of the General Motors Company, and the "man behind" the recently organized Chevrolet Motor Company, is the reported purchaser of 40 acres of land on Woodward avenue, north of the car barns, in Highland Park, which was sold by the Highland Park Land Company last week. Mr. Durant will neither affirm nor deny the report, but it is taken for granted in motor car circles here that he is the buyer and that he has acquired the property for the Chevrolet Motor Company as a site for a factory. The price paid was about \$160,000.

While its plans have been kept well under cover, it seems to be pretty generally understood by men in the business that the company is preparing to manufacture two models, a "four" and a "six," both of French design and right up to the minute in the matter of equipment.

The Highland Park Land Company, from whom the site for the Chevrolet plant is reported to have been purchased, is composed largely of men closely identified with the Ford Motor

Company, including Henry Ford, James Couzens, H. H. Rackham and others.

Work on the big plant of the Continental Motor Manufacturing Company, on Jefferson avenue, just east of the Hudson plant, is progressing rapidly, and an effort will be made to have it in operation by January 1. From 1,000 to 1,500 men will be employed. It will comprise eight buildings and a power plant. All of the buildings will be two stories high, except the machine shop (which will be a saw-tooth affair, 200 x 280 feet), and will be of steel and concrete construction, with steel sash. The factory at Muskegon will continue in operation, but the general offices of the company will be here. The present officers are: President and treasurer, B. F. Tobin; vice-president, R. W. Judson; secretary, H. J. Warner.

Detroit is to become the headquarters of the Mexico Latex Company, which manufactures rubber from the milk of the castilla plant. Louis F. Newman, of this city, is president.

A new sales company, known as the Marquette Company, has been organized as a subsidiary of the General Motors Company, and will handle the product of the Marquette Motor Company, manufacturing the Rainier and Welch-Detroit cars and the new Marquette. The officers are: Thomas Neal, president; O. C. Hutchinson, vice-president and manager; James T. Shaw, treasurer; Standish Backus, secretary; T. S. Merrill, assistant secretary and assistant treasurer. Headquarters have been established at 1302 Jefferson avenue. The merger of the Marquette Motor Company and the Welch-Detroit Company was announced some time ago.

A \$1,000,000 company is being organized by Detroit and Lansing capitalists to manufacture a new motor fire chemical engine, the distinctive feature of which is that it pumps water from the mains like any other fire engine, the water being charged with a chemical as it passes through the engine. The engine, as designed, has a capacity of 350 gallons of chemicalized water per minute. A plant is to be erected either in Detroit or Lansing as soon as the organization plans are completed.

The directors of the General Motors Company have declared a dividend of 3 1-2 per cent. on the preferred stock, to be paid on October 2 to the stockholders of record on September 22.

At the annual stockholders and directors' meeting of the Abbott Motor Company, held last week, the officers were all re-elected for the ensuing year, as follows: President, C. W. Jamieson; first vice-president, F. M. Knapp; second vice-president, H. M. Preston; secretary, Wade Millis; treasurer and general manager, M. J. Hammers; assistant general manager, B. C. Spitzley; sales manager, W. T. Bush.

### Pullman Company Builds Taxi

**YORK, PA., Sept. 18**—The Pullman Motor Car Company has gone in the taxicab building business, and this new type of car has been added to its line of models. About thirty of these cars are for the Pullman Taxicab Company, Philadelphia, and six were shipped last week to the Quaker City. The cars will be mounted on a regular Pullman chassis, Model O, 30 horsepower.

### Norwalk Company Settling Affairs

**NORWALK, OHIO**—The affairs of the Norwalk Motor Car Company, which have been in the hands of two receivers, appointed by the Common Pleas and Federal Courts, have now reached Attorney Ben B. Wickham, referee in bankruptcy for Huron county. The referee will call a meeting of the creditors to give them an opportunity to select a trustee.

## 907 Miles in 12 Hours

LONDON, Sept. 11—In a recent test carried out on the Brooklands track a particularly noteworthy feat was accomplished by the Sunbeam car. It consisted of driving a car fitted with a six-cylinder motor of 90-millimeter bore and 115-inch stroke (3 2-5 inches x 4 3-5 inches), for one round of the clock, averaging approximately 80 miles per hour. As a precautionary measure the tires were changed every two hours. It is estimated that the motor had to turn over at 1,800 revolutions per minute in order to attain the speed. The motor had the cylinders cast in two blocks of three, with all the valves placed on the same side, slightly inclined towards the combustion chamber.

The mixture was conveyed to the cylinders from the carbureter by means of a manifold bolted to the side of the motor opposite to that on which the valves are located, core-ways being cut in the cylinder casting, thereby heating the gases before being aspirated by the piston. Double distributor magneto with two sets of spark plugs were employed and the oil was fed to the various parts of the motor at a pressure of 30 pounds per square inch.

## Power Fire Engines in Parade

YORK, PA., Sept. 18—The first automobile combined pump engine, chemical engine and hose wagon owned in Pennsylvania was one of the features of the large firemen's parade last Thursday in this city at the convention of the Pennsylvania State Firemen's Association. The fire apparatus is driven by a six-cylinder, 90-horsepower engine and has a speed of 60 miles an hour. The car cost \$9,000.

H. G. Louser is chief of the Lebanon fire department which has the apparatus. There were three other automobile chemical apparatuses in line, one from Hose Company No. 3, Bristol, Pa., another from the Radnor Fire Company, Wayne, Pa., and the new chemical engine of the Reliance Fire Company, West York Borough. The latter was built by the Martin Carriage Company, York, Pa., and is the first in the local fire department. There were over 100 fire companies from different parts of the State, and over 7,000 men in the parade.

## Detroit Sees First Show

DETROIT, Sept. 18—A most complete and attractive automobile show is the one at the State Fair this year, opening today. Many of the local manufacturers, notably the Chalmers Motor Company and the Warren Motor Car Company, are showing their complete lines for 1912. The commercial car interests are also well represented.

One of the interesting exhibits is the Colonial electric, manufactured by the newly organized Colonial Electric Company, of this city. The car on exhibition is the first one completed and is being shown for the first time. Its distinctive features are an unusually long wheelbase and an extra width of body. It is of the five-passenger brougham type, with semi-elliptical springs forward and full elliptical in the rear. It has a bevel-gear shaft drive with full floating type rear axle and a Westinghouse motor and controller. The car is richly upholstered in dark blue broadcloth.

The new Chalmers "Thirty-six," which made its appearance about two months ago, is featured in the Chalmers exhibit. This car is shown in both fore-door touring car and fore-door pony tonneau types.

Other exhibitors are: The Annette Automobile Garage, Jackson Automobile Company, Cole Motor Sales Company, Cunningham Automobile Company, showing the Flanders electric, E-M-F "Thirty" and Flanders motorcycle; Rapid Motor Vehicle Company, Brush-Detroit Motor Company, Pratt-Carter-Sigsbee Company, Detroit Hupmobile Sales Company, Detroit Motor Wagon Company, Commerce Motor Car Company, Elmore Automobile Company, Brady Automobile Company, showing the Hudson line; Day Automobile Company, Lion Motor Sales Company, General Motors Company, Abbott-Detroit Automobile Company, Cartercar Automobile Company, Regal Automobile Company, Oakland Automobile Company, Poss Motor Company, Grant Bros. Automobile Company, Cadillac Motor Car Company, Buick Automobile Company, Overland Automobile Company, United Motor Detroit Company, showing Columbias and Maxwells; Seitz Motor Truck Company, Mitchell-Lewis Company, Flanders Manufacturing Company, Pontiac; W. A. Patterson Automobile Company, Miller Motor Car Company, Foster Motor Sales Company and the White Motor Company.

# Calendar of Coming Events

### Shows, Meetings, Etc.

- Sept. 25-30.....Atlantic City, N. J., Convention and Exhibition of the Carriage Builders' National Association.
- Jan. 1-5, 1912.....New York City, Grand Central Palace, Annual Show, Automobile Manufacturers' Association of America.
- Jan. 6-13.....New York City, Madison Square Garden, Twelfth Annual Show, Pleasure Car Division, Automobile Board of Trade.
- Jan. 6-20.....New York City, Madison Square Garden, Annual Show, Motor and Accessory Manufacturers.
- Jan. 10-17.....New York City, Grand Central Palace, Twelfth Annual Show, National Association of Automobile Manufacturers; also Motor and Accessory Manufacturers.
- Jan. 15-20.....New York City, Madison Square Garden, Twelfth Annual Show, Commercial Division, Automobile Board of Trade.
- Jan. 18-20.....New York City, Annual Meeting of the Society of Automobile Engineers.
- Jan. 27-Feb. 10....Chicago Coliseum, Eleventh Annual Automobile Show under the auspices of the National Association of Automobile Manufacturers. Pleasure cars, first week. Commercial vehicles, second week. Accessories, both weeks.
- March 2-9.....Boston, Mass., Tenth Annual Show, Boston Automobile Dealers' Association, Inc.

### Race Meets, Runs, Hill-Climbs, Etc.

- Sept. 21-22.....San Francisco, Cal., Commercial Reliability Run. San Francisco Examiner.
- Sept. 23.....Philadelphia (Point Breeze), Track Races, Philadelphia Automobile Trade Association.
- Sept. 23-25.....Detroit, Mich., Track Races, Michigan State Agricultural Society.
- Sept. 30.....Guttenburg, N. J., Track Races.
- Sept. 30.....Bridgeton, N. J., Track Races, South Jersey Motor Club.
- Sept. 30.....Flint, Mich., Track Races.
- Oct. 6-13.....Chicago, Ill., Thousand-Mile Reliability Run, Chicago Motor Club.

- Oct. 7.....Danbury, Conn., Track Races, Danbury Agricultural Society.
- Oct. 7.....Philadelphia, Fairmount Park Road Races, Quaker City Motor Club.
- Oct. 7.....Springfield, Ill., Track Races, Springfield Automobile Club.
- Oct. 9-13.....Denver, Colo., Reliability Run, Denver Motor Club.
- Oct. 10.....Bedford, Ind., Hill Climb.
- Oct. 11.....Oklahoma City, Okla., Reliability Run, Oklahoma State Automobile Association.
- Oct. 12-13.....Peoria, Ill., Track Races, Peoria National Implement and Vehicle Show.
- Oct. 14.....Santa Monica, Cal., Road Races.
- Oct. 14 (to 25)....New York City, Start of the Annual Glidden Tour, en route for Jacksonville, Fla.
- Oct. 16-18.....Harrisburg, Pa., Reliability Run, Motor Club of Harrisburg.
- Oct. 21.....Atlanta, Ga., Track Races.
- Oct. 31.....Shreveport, La., Track Races, Shreveport Automobile Club.
- Nov. 1.....Waco, Tex., Track Races, Waco Auto Club.
- Nov. 2-4.....Philadelphia, Reliability Run, Quaker City Motor Club.
- Nov. 3-4.....Columbia, S. C., Track Races, Automobile Club of Columbia.
- Nov. 4-6.....Los Angeles-Phoenix Road Race, Maricopa Auto Club.
- Nov. 9.....Phoenix, Ariz., Track Races, Maricopa Automobile Club.
- Nov. 9, 10, 12....San Antonio, Tex., Track Races, San Antonio Auto Club.
- Nov. 27.....Savannah, Ga., Vanderbilt Cup Race, Savannah Automobile Club.
- Nov. 30.....Los Angeles, Cal., Track Races, Motordrome.
- Nov. 30.....Savannah, Ga., Grand Prize Race, Savannah Automobile Club.
- Dec. 25-26.....Los Angeles, Cal., Track Races, Motordrome.

### Foreign Fixtures

- Oct. 1.....Gaillon, France, Hill-Climb.
- Oct. 12-22.....Berlin, International Automobile Exhibition.
- Nov. 3-11.....London, Eng., Olympia Show.

### Expert Reports on Aluminum

WASHINGTON, D. C., Sept. 18—Not over a generation ago aluminum was little more than a curiosity. It was worth \$15 a pound and its total production in the United States was less than 100 pounds a year, notwithstanding the fact that aluminum is the most abundant of all the metals in the earth's crust, of which aluminum oxide forms about 15 per cent.

The great progress made in the industry is noted in the fact that a report on bauxite and aluminum for 1910, just published by the United States Geological Survey, shows a consumption in this country in that year of 47,734,000 pounds, valued at nearly \$12,000,000. The price has dropped from \$1 an ounce to about 23 cents a pound.

W. S. Phalen, author of the report, states that although aluminum has in recent years become a most important economic metal, it is at present produced only from bauxite, a comparatively scarce mineral, and that even the great discovery which made this possible is only the first stage of wresting the metal from its various rock and earth combinations. Aluminum is an essential constituent of all important rocks, except sandstone and limestone, and is found in all clays. The supply is therefore practically limitless, awaiting only the perfection of a process for cheap extraction.

There are a number of recently patented processes which show progress in the cheap extraction of the metal from the common sources of supply:

### Colonels Must Show Double Numbers

LOUISVILLE, Sept. 18—An opinion from the Attorney-General of Kentucky has been received by the Louisville Automobile Club on the disputed question of numbers on automobile lamps. The Attorney-General quotes the last half of Section 4, Chapter 81, of the Acts of 1910, which act is entitled "An act defining motor vehicles, providing for the registration of the same and uniform rules regulating the use and speed thereof," which reads as follows:

"Upon each of the glass fronts of the two first mentioned lamps showing white lights shall be displayed in such manner as to be plainly visible when such lamps are lighted, the number of the certificate issued aforesaid by the Secretary of the State, and in addition thereto the letters 'KY,' such figures to be in separate Arabic numerals not less than 1 inch in height."

"My opinion," says the Attorney-General, "is that this section of the statute is mandatory and that every owner or person using or operating an automobile upon the public highways, streets, etc., of the State or any city must comply with the provisions of Section 4 of the act. In view of the provisions of Section 3, which seem to fully provide for the identification of the car, the requirements of Section 4 seem to be superfluous, but thus the law is written, and so long as the statute remains unrepealed, or until amended, it should be obeyed by those owning and operating automobiles."

### Indianapolis Seeks City Automobiles

INDIANAPOLIS, IND., Sept. 18—After considerable deliberation, the Indianapolis Board of Public Safety has awarded contracts for four new pieces of motor fire apparatus for the fire department. These contracts are as follows:

Squad wagon, carrying eight men, 250 feet of chemical hose and 35-gallon chemical tank, Meridian Auto Company, representing Packard Motor Car Company, \$5,277.40; ladder truck, carrying 130 feet of ladders, Mais Motor Truck Company, \$4,800; combination hose and chemical wagon, \$5,000, and pump engine pumping 600 gallons of water a minute, \$7,500, to American Le France Engine Company, Elmira, N. Y.

The board of school commissioners has received the following bids on a truck for the school supply department: Mais Motor Truck Company, chassis, \$2,500; J. E. Burkhart, representing General Vehicle Company, 2,000-pound truck, \$2,700 and

\$3,390, according to batteries; 4,000-pound truck, \$3,450 and \$3,820, according to batteries.

Thomas A. Winterrowd, building inspector, has asked the Board of Public Safety to buy two gasoline runabouts for the deputy building inspectors under him. The Board of Health is asking bids on a new gasoline ambulance for the city hospital, which already has one such ambulance in service.

### Motorizing Lansing's Fire Fighters

LANSING, MICH., Sept. 18—It is expected that by January 1 Lansing will have a fire department consisting almost entirely of automobile apparatus. The Board of Police and Fire Commissioners has decided to make the combination wagon at station No. 4 into an automobile combination truck. The board has taken similar action in regard to the combination wagon at station No. 3. The work will be done by the Olds Motor Works.

This will leave only one piece of horse-drawn apparatus in the whole department and that probably will be supplanted shortly.

### Trunk Line Will Tap Desert Country

PORTLAND, ORE., Sept. 18—Burns, Ore., and the city of Portland are to be brought eight days nearer together, and Portland given a lever which should mean the securing of the immense central Oregon business as the result of the establishment of automobile freight truck service between the cities of Bond and Burns, Ore. The total distance over which the big freight trucks will run is 138 miles, practically all of which is over a desert country, as accessible in the Winter as in Summer.

Negotiations pending for some time between the merchants of Burns and the Central Oregon Trucking Company, of which Clifford C. Harrison, of Portland, is the head, were brought to a close the past week. Practically all of the freight received by the Burns merchants will now be routed through Bond, and thence over 138 miles of desert country into Burns.

### Will Race This Week at Hartford

HARTFORD, CONN., Sept. 18—After having been indefinitely postponed, the auto races which were to have been held at Charter Oak Park September 9 and which were called off on account of a muddy track, will be held September 21, the Automobile Club of Hartford having decided to promote them.

The races were arranged by the Connecticut Fair Association as the closing feature of the State Fair held Labor Day week.

### Reo Company Plans Big Production

LANSING, MICH., Sept. 18—According to General Superintendent Richard H. Scott of the Reo Motor Car Company a conservative estimate is that the production of the 1912 model will amount to 9,000 cars.

The capacity of the Reo plant is 1,000 cars a month, but that capacity cannot be reached in October, November or December. But by January the company hopes to have its raw material pushed far enough along through the various departments so that the capacity of the factory will be reached. For eight months the departments will be operated to their full extent. During some of these months it is expected the factory will exceed its normal capacity.

### Insurance Company Fights Bar

DES MOINES, IA., Sept. 18—The American Fidelity Company, an insurance concern with headquarters in Montpelier, Vt., has filed suit against John Bleakly, auditor of State of Iowa, asking that the auditor be restrained from preventing the company from operating in Iowa its business of insuring automobile owners against injuries in accidents, and being made defendant in damage cases.

## Tire Situation in Great Britain

**A**UTOMOBILE tire manufacturers in America may profit by digesting the following points relative to the motor car in the United Kingdom: First, the popularity and usefulness of and, consequently, the increased demand for taxi motor cabs are potent factors in the life of Britishers, for these taxis are rapidly taking the place of the horse-drawn hansom cab even in the remotest corners of Great Britain. This not only means more taxi-cabs and automobiles, but a corresponding increase in the demand for tires. Secondly, there is a growing market for the freight automobile throughout the United Kingdom. Third, it is evident that American automobile manufacturers are daily increasing their exertions relative to the acquirement of a share of the British motor car and tire trade. These facts have awakened the people to a sense of the really good quality of the American-made automobile and they are beginning to talk about the product in a favorable spirit. But shall they assert that the American manufacturer would sell more machines and tires if he were to emulate the trade methods of the British and even of the Continental European manufacturer and merchant, who make it the invariable rule to advertise extensively, insist strenuously upon being represented at all of the motor car shows, and to so conspicuously display their products that they shall at all times be within view of the public. Frequently, the outlay involved is prodigious, but the British manufacturer contends that expenditure of capital is imperative if he would keep in the limelight with his competitors. The same policy is incumbent upon the American manufacturer who would get his motor cars or tires before the eyes of the people. The head display agencies for British and Continental European-made cars are London and Manchester, sub-agencies being maintained in the smaller Provincial cities, such as Leeds, Liverpool, Birmingham and even Southampton. But so far as the manufacture of rubber tires is concerned, Manchester is the British center. Not alone are English firms in this line eminent, but all of the leading Continental European manufacturers of tires maintain depots in Manchester for the display of their product. While American-made tires and automobile accessories are sold to some extent in the vicinity of Manchester, none of the American manufacturers have depots there, they apparently regarding London a sufficiently near-of-access goods depot from which to supply the trade of the middle counties.

The proper way for American manufacturers to secure a share of the British tire trade would be to establish a headquarters, say, in London, where, provided a great variety of goods was displayed, orders could be filled promptly. Sub-agencies in Manchester and Liverpool might do well. But when a dealer carrying on business in a provincial town finds himself in need of automobile accessories, London is first in his mind. Therefore, local agents in towns like Leeds and Sheffield might not prove to be any material benefit to the manufacturer, except under special conditions. For example, Sheffield local dealers are supplied from the manufacturer's agent, or from the manufacturer direct with a stock sufficiently large to accommodate the trade in the immediate vicinity. Settlement is made for all goods sold at the end of each month. Twice during the twelve months an account of stock is taken. Upon these occasions slow-selling goods are exchanged at the London headquarters, the manufacturer giving ready-sale stock in its place. American-made tires are not as much in demand in Sheffield as are French and British-made tires. French manufacturers have established headquarters in London. British manufacturers are experimenting daily in order to find out if possible a tire which will run without the danger and the terrorizing effect of the side slip. And there is

nothing that is quite as slippery as London's South American red-cedar paved streets on a dirty day. To this end a new disposition of rubber and steel is used in the tire. The finest grade of Para rubber is employed, forming a tread containing a network of the finest steel fiber; which resembles hairs. This combination produces a tread whose resiliency equals that of rubber alone, while it is also said to be practically impenetrable. It contains a non-skid surface, which causes it to adhere to the roadbed.

Discounts, as allowed by various manufacturers in Great Britain, differ considerably, ranging all the way from 10 to 50 per cent., as an inducement for pushing sales of automobiles and accessories. A rebate, in addition to the ordinary cash discount and based upon the amount of business transacted, is made at the end of the season, in the event of the terms of the contract regulating the sale price to the public not having been violated. A leading Continental European manufacturer is credited with allowing from 10 to 20 per cent. along the same lines of sale as stated.

In Edinburgh and vicinity local agents of British manufacturers of tires supply the automobile trade. Foreign manufacturing companies are represented by agents who serve in the capacity of distributors in London. Motor cars in Scotland are sold by firms who deal in automobiles and accessories. Agents handle the products of numerous manufacturers. There are nine firms in Edinburgh selling one particular type of British-made motor car tire. Commercial travelers sent out by British manufacturers are to be met with in all sections of the United Kingdom, going among dealers soliciting trade. The manufacturers supply the tires and every thirty days the stock is checked up until at the end of six months or twelve months the manufacturers take back the stale stock, replacing it with fresh goods. Catalogues contain but one price for each article listed, and upon this price to the trade all discounts are based. A 25 per cent. discount on list prices, 5 per cent. on cash sales (payment within seven days is regarded as cash) or 2 1-2 per cent. at thirty days are the prevailing terms.

Scotland has shown a kindly disposition toward French and German manufacturers of rubber tires, the sales of which are on the increase, while American-made tires also receive favorable comment, although the latter have not been as extensively displayed as the custom of the country calls for. In order to get a foothold it is necessary that goods should be placed with local agents or factors, and the terms of sale must need be quite as favorable as those which are granted by French, German and British makers, the latter controlling a goodly portion of the Scotch trade in tires, as well as in automobile accessories. The British firms expend for advertising such sums as the importance of the market warrants.

**ACETYLENE LAMPS IN WINTER**—Since lamps are used much less frequently in Winter than in the regular touring season, they are often neglected, the generator being left with stale or partially used carbide in the chamber, and the residue being allowed to clog up the water port and the waste ports. The rubber lamp connections and gasbag suffer also by deterioration as well as the burners and gas valves. For the proper maintenance of the system, strict cleanliness should be maintained at all times and the various parts should be examined and replaced from time to time as necessary. The results of neglect are seen every spring in lime deposits which have to be removed by means of a cold chisel, in porous connections and in clogged burners which resist the cleaning wire and necessitate the scraping of the burners.



1—Over a stretch of fine dirt road, southward bound  
 2—Scene on the Cow Pasture River, taken from bridge over the gorge  
 3—The far-distant hills rise and fall like billows on the sea  
 4—The winding Potomac narrows as Harper's Ferry is approached

## Up the Shenandoah

WITH the approach of cool weather there seems to be a tendency on the part of the compasses of motor tourists to point southward. Although little pleasure travel has as yet headed for the extreme South, many motorists have cast an attentive eye upon the Virginias at, say, a point approximating Hot Springs.

Travelers from New York City who contemplate such a tour may well go via Morristown, Easton, Reading and so on, as is very graphically represented in the trunk line chart which is one of the unique features of the *Automobile Blue Book*, Volume 3, covering New Jersey, Pennsylvania and the South-east, should be used on this trip.

Tourists from Pittsburgh and the West may well follow the trail of the *Blue Book* official scout who went directly south from Cumberland on a very nice shale road to Monterey and then crossed the mountains on a fairly good dirt road which is being improved. The trip is delightful and the scenery such as to arouse enthusiasm. This trip is 88 miles shorter for tourists from the Pittsburgh section, who might otherwise go by way of Winchester and Staunton to Hot Springs.

Whichever way the tourist approaches the region, let him recall the fact that he traverses one of the richest fields of history in America. This statement does not apply particularly to the battlefield of Gettysburg and the many scenes of Civil War conflict. This is also the great region of colonial activity.

How true this is appears when one remembers that Philadelphia was the leading city of the country in the early days. All roads led to Philadelphia. All the colonists who started west long before Horace Greeley was alive to point the way made their exit from the coast and entrance into the great beyond by way of Lancaster and Bedford, or Cumberland and Uniontown. These places bore different names in those days. When General Braddock planned the road that bore his name, or when Forbes' Road took the all-Pennsylvania route to the strategic point of Fort Duquesne, settlements were few and far between. Indian trails fit only for pack trains were the chief "highways."

That the old "National Highway" of this section should have marked the beginning of the good roads movement in this country is also not without significance. The time is coming very shortly when this section will reassert its interest in good highways. Pennsylvania has been very devoted to the Cumberland Pike and is making considerable improvements. Virginia has evidenced an awakening in this respect also, especially in the vicinity of Richmond. The work of the Touring Club of America in connection with the American Association for Highway Improvement is already bearing fruit; and the Good Roads Congress to be held at Richmond the week of November 20-24 will focus public attention upon this very important subject.

Undoubtedly, this region will one day rival New England as an automobile touring ground. It is crowded with scenes of varied interest. Nature here is ever attractive. The coast is bordered by a wide belt of rich agricultural land. Up to the foothills



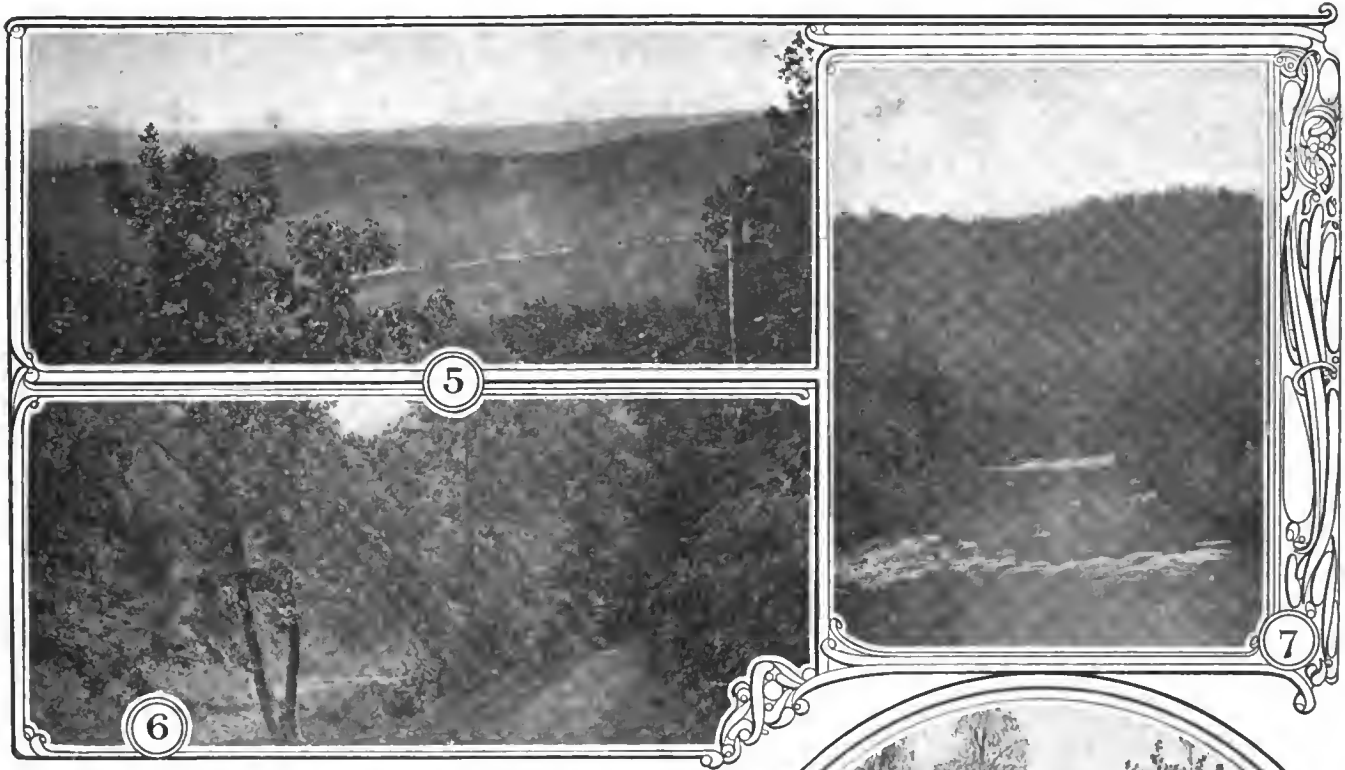

5—The view from Virginia Hot Springs is unsurpassed  
 6—Glimpse of virgin country en route from Cumberland to Hot Springs  
 7—Cow Pasture River is decidedly more glorious than its name  
 8—The road from Cumberland to Hot Springs is now aglow with crimson



## Valley to Hot Springs

of the mountains sweep the fields of grain; and then the vast mountain ranges rise in great billows from the Blue Ridge to the Ohio.

At the present time fords constitute one of the chief obstacles to completely satisfying motor travel in Virginia. The route to Hot Springs via Monterey, for instance, has some fords that might be bad in very wet weather. Nor can one deny that there are such well-known features as ditches and waterbars, but they are not bad. The 150 odd miles are covered on a good dirt road and the scenic delights make the trip in itself well worth taking.

From Cumberland one goes 13.1 miles to Frankfort, crossing the iron bridge over the Potomac River, 7.8 miles beyond. There are several sharp curves in the next score of miles, also several iron bridges and several small hamlets. The inhabitants of these queer places are just beginning to appreciate the increasing volume of motor travel, and, if there be any value in modern civilization, will quickly gain the polish that has already begun to shine in the small towns of the North. It is an undoubted fact that the growth of motor touring has brought many a village into the current of modern life, from which it dropped when the stage coach stopped and the railway went some other way.

Petersburg is entered on Keyser avenue. Crossing the long iron bridge, the traveler comes to a winding, hilly road from which the views are splendid. When the odometer reads 103 or thereabouts the route crosses the Virginia State line, shortly winding through the virgin woods. Monterey and Vanderpool are reached in quick succession. Monterey is 112 miles from Cumberland. Hot Springs is 36 miles beyond. At Warm Springs (143.5) one strikes a stretch of macadam, and 4 miles farther is a tollgate, which it costs a quarter to pass.

One has now reached the wonderful thermal springs, known all over the world and annually visited by many wealthy people. The valley is from 2,000 to 2,500 feet above the sea level.

The return trip to the northward should not be begun without remembering that to the south between Lexington and Roanoke is the Natural Bridge, 215 feet high, 100 feet wide and 90 feet clear span. Many prominent men before you have visited the bridge, including George Washington, who just naturally carved his name high up on the rock.

Another great natural wonder of this region is the Luray Cavern, reached over fair roads east from New Market on the route from Staunton to Winchester. It is a wonder spot rivaling the Kentucky Mammoth Cave. En route to Staunton, the tourist should take advantage of the new bridge over Cow Pasture River. As the pictures indicate, the views are very pretty, and the travel is better and 6 miles shorter. The National Highway is in fine shape to Winchester and to Hagerstown, according to official reports just received by the Touring Club of America. Road conditions in many parts of the country vary almost as the weather varies, so that the tourist should get the latest information before he starts.

# Stresses and Strains in Tires

## Part II.

Translation from an article by Henri Petit, in *La Technique Automobile et Aérienne*

THE warp and the woof threads in pneumatic tires are placed at an angle of approximately 45 degrees in the principal plane of the surface. As the resistance of the canvas is none other than that of the warp and the woof it is interesting to look for the resistance imposed on the threads.

In articles that have appeared on the manufacture of tires we find that the angle of the threads, which is about 90 degrees at the bead, comes down to 70 degrees at the center portion of the tire.

It is proposed to first of all calculate the tensions following the principal planes at the points A and C in Fig. 1.

Supposing the tire is cut in a meridian plane. The layers will have to withstand a resistance as follows in order to remain stuck together:

$$\frac{p \cdot \pi r^2}{2 \pi r}$$

which equals  $\frac{p r}{2}$ .

This is the tension in the equatorial plane which can be designated by  $T_E$ .

If we now cut the tire in the equatorial plane the force which will tend to sever the two halves will be equal to

$$p [\pi (R+r)^2 - \pi (R-r)^2]$$

that is to say,

$$4 \pi R r p$$

The tension for unity of length along the equatorial circle of the greatest radius will be:

$$T_M \text{ Min.} = \frac{4 R r \pi}{2 \times 2 \pi (R+r)} p$$

$$= \frac{R r}{R+r} p$$

and the tension for unity of length along the small circle will be:

$$T_M \text{ Max.} = \frac{4 \pi R r}{2 \times 2 \pi (R-r)} p = \frac{R r}{R-r} p$$

Let these meridian tensions be called  $T_M$  Min. and  $T_M$  Max.

Near the beads the threads of the canvas are at an angle of 45 degrees to the direction of meridian and equatorial tensions.

The tension  $t$  following these threads will be (see Fig. 2):

$$t = \frac{\sqrt{2}}{2} (T_E + T_M \text{ Max.})$$

that is,

$$t = \frac{\sqrt{2}}{2} p r \left( \frac{1}{2} + \frac{R}{R-r} \right)$$

$$= \frac{p r}{2 \sqrt{2}} \frac{3 R - r}{R r}$$

At a point of the great equatorial circle where the threads form between them an angle  $\alpha$  ( $\alpha < 90^\circ$ ) the tension of these threads will be, according to Fig. 3,

$$T = \frac{1}{2} \left[ \frac{T_M}{\cos \frac{\alpha}{2}} + \frac{T_E}{\sin \frac{\alpha}{2}} \right]$$

that is,

$$T = \frac{1}{2} p r \left[ \frac{R}{R+r} \frac{1}{\cos \frac{\alpha}{2}} + \frac{1}{2 \sin \frac{\alpha}{2}} \right]$$

Let us apply these formulæ to some standard sizes of covers.  
1° 760 × 90 R = 33.5 r = 4.5

Tension at the Bead of the Cover

$$t = \frac{5 \times 4.5}{2 \sqrt{2}} \cdot \frac{33.5 \times 3 - 4.5}{29}$$

= 26.5 kilogrammes approximately.

The tension at the running tread [angle of the threads  $\alpha$  = about 80°].

$$t = \frac{5 \times 4.5}{2} \left[ \frac{33.5}{38 \cos 40^\circ} + \frac{1}{2 \sin 40^\circ} \right]$$

= about 21 kilogrammes.

The tension is appreciably less at the tread, as can be seen.

This explains why when a tire bursts (unless the burst is due to a cut) the tear generally takes place at the side wall. Near to the point of attachment, where the tension is greatest, the tire is reinforced by the two small layers. Generally the tire bursts just below these layers.

The tensions that have just been calculated show what is supported by the general body of canvas.

Each layer is subjected to  $n$  times less tension.

For the sake of argument we will suppose the tension on all the layers to be equal, as this is what makers strive for in making the tires.

For the example taken above of a 760 × 90 tire the tension is supported by at least four layers of canvas.

Near the rim the two layers must be taken into consideration as well and the total tension divided by 6.

$$\frac{26.5}{6} = 4.5 \text{ kilogrammes.}$$

Canvas of good quality should not break unless submitted to an effort of 56 kilos per square centimeter. The coefficient of security is therefore 12.

Another interesting point is at what part of a tire the work of each layer of canvas is greatest, granted that their number is variable.

Near the point B in Fig. 1 it can be seen that the tensions in the main planes are respectively.

Tension in the perpendicular plane to the meridian:

$$t = T_E$$

$$= \frac{p r}{2}$$

Tension in the meridian plane:

$$T_M = \frac{\rho \cdot 2\pi R \times 2r}{2 \times 2\pi R} = \rho r$$

The angle that the threads make being  $a$  at this point, the forces that will act upon them can be expressed by (Fig. 3)

$$T = \frac{1}{2} \left[ \frac{T_M}{\cos \frac{a}{2}} + \frac{T_E}{\sin \frac{a}{2}} \right]$$

continuing to call  $T_E$  the tension in the main plane perpendicular to the meridian plane.

But in replacing  $T_M$  and  $T_E$  by their values

$$T = \frac{1}{2} \rho r \left[ \frac{1}{\cos \frac{a}{2}} + \frac{1}{2 \sin \frac{a}{2}} \right]$$

The angle of the threads for the 760 x 90 tire that we have chosen is, for example, about 85 degrees.

From which the value of  $T$ :

$$T = \frac{1}{2} \times 5 \times 4.5 \left[ \frac{0.737}{1} + \frac{1}{2 \times 0.676} \right] = \text{about } 22.5 \text{ kilogrammes.}$$

This tension is not much greater than that which exists at the rolling tread.

At the point B (in Fig. 1) the number of layers of canvas is only 4. The tension of each thread of the canvas has a value  $\frac{22.5}{4} = 5.5$  kilogrammes.

More, therefore, than the tension of the bead.

The tension increasing when a displacement is made from B to C, it can easily be seen that the tension of each stand or thread will be maximum following along the border of the bead strip.

This is borne out by practice. When a tire bursts prematurely it generally takes place at this point

II° 820 x 120 tire  $R = 35$   $r = 6$ .

$$\frac{R}{r} = \text{about } 6.$$

In applying the formulæ we have:

1. Tension at the bead for the entire canvas structure ( $\rho = 6$  kilogs.).

$$t = \frac{\rho r}{2\sqrt{2}} \frac{3R-r}{R-r} = 44 \text{ kilogs.}$$

which for each layer equals:

$$\frac{44}{8} = 5.5 \text{ kilogs.}$$

taking the side strip into consideration.

2. Tension at the running tread ( $a = 70^\circ$ )

$$t = \frac{1}{2} \rho r \left[ \frac{R}{R+r} \frac{1}{\cos \frac{a}{2}} + \frac{1}{2 \sin \frac{a}{2}} \right]$$

with

$$\begin{aligned} \frac{a}{2} \cos \frac{a}{2} &= 0.819 \\ \frac{a}{2} \sin \frac{a}{2} &= 0.574 \\ t &= 34.5 \text{ kilogs.} \end{aligned}$$

3. Tension at the walls ( $a = 80^\circ$ ).

$$T = \frac{1}{2} \rho r \left[ \frac{1}{\cos \frac{a}{2}} + \frac{1}{2 \sin \frac{a}{2}} \right]$$

with

$$\begin{aligned} \frac{a}{2} \cos \frac{a}{2} &= 0.766 \\ \frac{a}{2} \sin \frac{a}{2} &= 0.643 \\ t &= 38 \text{ kilogs.} \end{aligned}$$

Which is equivalent for each thread:

$$\frac{38}{6} = 6.3 \text{ kilogs.}$$

III. 935 x 135 tire

$$R = 40 \quad r = 6.8 \quad \frac{R}{r} = 6$$

1. Tension at the bead ( $\rho = 7$  kilogs.).

$$t = \frac{\rho r}{2\sqrt{2}} \frac{3R-r}{R-r} = 57 \text{ kilogs.}$$

which is equivalent for each stand  $\frac{57}{9} = 6.33$  kilogs.

2. Tension at the running tread ( $a = 70^\circ$ ).

$$t = \frac{1}{2} \rho r \left[ \frac{R}{R+r} \frac{1}{\cos \frac{a}{2}} + \frac{1}{2 \sin \frac{a}{2}} \right]$$

with

$$\begin{aligned} \frac{a}{2} \cos \frac{a}{2} &= 0.819 \\ \frac{a}{2} \sin \frac{a}{2} &= 0.574 \\ t &= 4.55 \text{ kilogs.} \end{aligned}$$

3. Tension at the walls.

$$T = \frac{1}{2} \rho r \left[ \frac{1}{\cos \frac{a}{2}} + \frac{1}{2 \sin \frac{a}{2}} \right]$$

with

$$\begin{aligned} \frac{a}{2} \cos \frac{a}{2} &= 0.766 \\ \frac{a}{2} \sin \frac{a}{2} &= 0.643 \\ t &= 50.25 \text{ kilogs.} \end{aligned}$$

which for each thread equals

$$\frac{50.25}{7} = 7.2 \text{ kilogs.}$$

It will be seen from the foregoing that the tension for each thread proportionately increases with the increase in diameter of the tire. But in all cases the coefficient of security remains superior to 8.

(To be continued.)

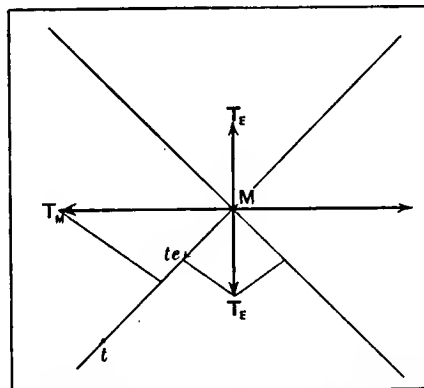

Fig. 2—Diagram showing the tension of the threads at a 45-degree angle

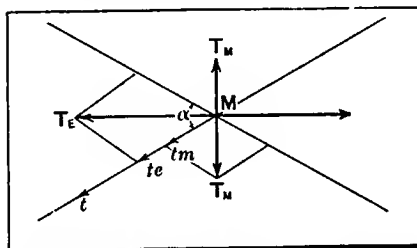

Fig. 3—Diagram showing tension of the threads at an angle less than 90 degrees

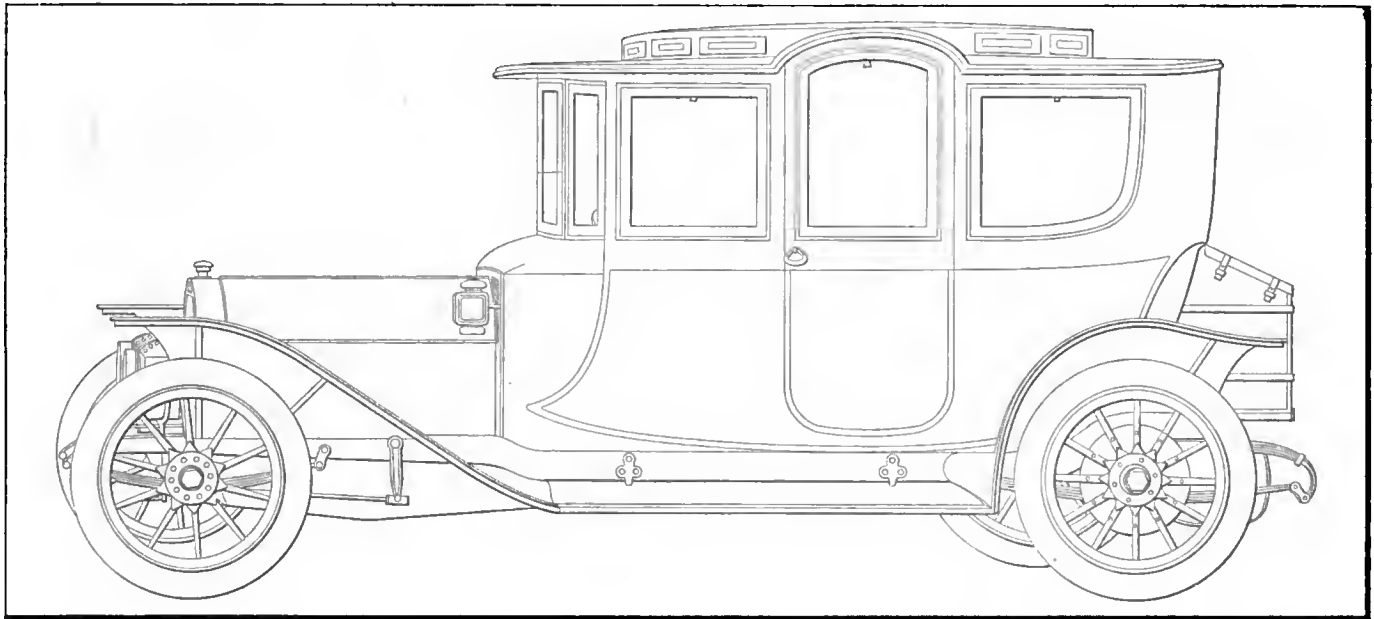

Fig. 1—Illustrating a new design of single-compartment limousine, showing generous proportions of arched door and maximum inside height

# New Single Compartment Limousine

BY GEORGE J. MERCER

THE maximum amount of comfort for the occupant should seem to be the slogan of the automobile body designer, if one would form his deductions from the appearance of the new designs of bodies that are coming out for Fall and Winter use. There is a general tendency to increase the thickness of the upholstery wherever possible and particularly in the seat cushions, which are not only made thicker but are being made with more slope toward the rear. There are novelties in appointments and in trimming designs, the addition of fore doors for the protection of the driver and the low-hung chassis with the drop center that allows of low entrance way are here.

Chief among the conveniences, or more properly speaking one of the necessities of a well-designed body, is the provision made for generous door width and ease of entrance and exit. These should be such as to suit the widest range of persons, and particularly those that occupy the rear seats of the car.

Figs. 1, 2, 3, 4 and 5 illustrate a new design, single-compartment limousine, having accommodations for seven passengers

and in which the entrance way is ample and commodious. These five illustrations show a body with arched doors and ventilator dome in the roof. Both of these features have individually found favor with the public and their use collectively, as here illustrated, makes possible the maximum height for door entrance and also the maximum standing height inside the body, without distorting the body dimensions or taking from the general attractiveness of the design. The actual gain in height is  $3\frac{1}{2}$  inches in this instance and it is possible to make still further gain if it were required.

Fig. 1 illustrates the body with a slight perspective and mounted on a low-center chassis, having the gasoline tank at the rear, below, and the drive is on the left side. The trunk compartment is shown at the rear of the body. Figs. 2, 3, 4 and 5 show in detail the working out of the design and the arrangement of the interior seating. The dimensions are indicated.

The arched door, which is one of the distinctive features of this design, is placed about midway of the body and there is a

single entrance on each side, in line across and directly facing; this entrance gives ample and free access to the rear and the small side seats, and the entrance to the front seat is made by tilting up the right half as illustrated by dotted lines on front view, Fig. 5. In Fig. 2 is shown the back of the seat dropped down preparatory to raising the seat cushion. The back of this seat is divided in the center and either half can be made to fold down, making possible for the driver to leave by first lowering the back of his seat and then stepping over the seat to the floor at the rear. The ventilator dome is carried sufficiently forward to give the maximum walking height as far as the front of this seat.

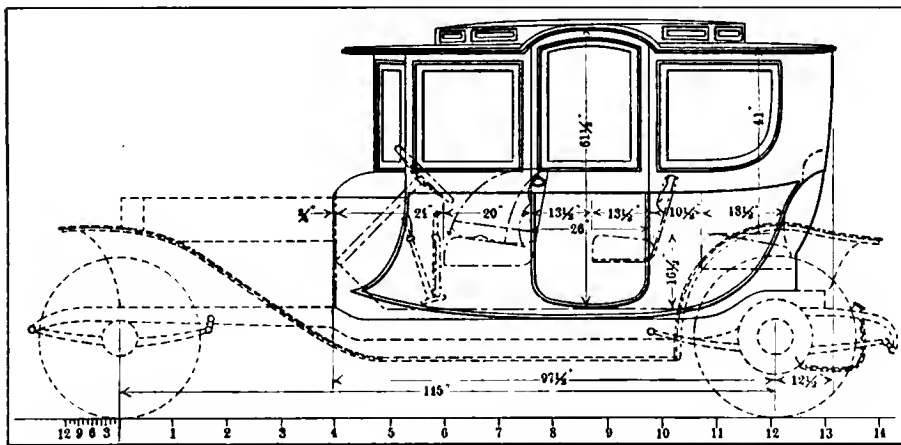

Fig. 2—Diagram showing the dimensions of single-compartment limousine body

The overall body dimensions of the design illustrated are no more than the average seven-passenger limousine, exclusive of the dome in the roof. This latter not only gives extra height inside and permits of a higher doorway, but the glass frames are made to open so that a perfect ventilation of the car is assured, without the disadvantage of a strong wind blowing onto the car occupants. For warmer weather, it is possible to entirely open up the car by dropping the glass frames in the doors and at the back and front of the doors on the sides, as well as open up the front or wind shield glass; in addition there are small screen ventilators in the dash at each side of the bonnet. The single-compartment body permits of the maximum room inside lengthwise, as the division is cut out or done away with and it also permits of a clear vision ahead for all the occupants of the car; and in the design illustrated the front corner windows are rounded slightly to better accommodate a view ahead for those seated at the rear.

Body designs, as here illustrated, are gotten up for a specific use and it is intended to be used during that part of the year when the weather is cold and disagreeable; every occupant of the car is comfortably housed and if it was desired the body could be heated from the exhaust. The trimming, the appointments and the general tone of the finish and the painting should be of the very best that money can purchase, for whereas bodies that are intended for Summer use are made to look light and attractive for the hot weather, such a design as here shown can be made to carry all the weight of luxurious fittings that the wish of the purchaser can desire.

Another feature that is becoming quite common among the owners who possess more than one car is, wherever it is practicable, to have the chassis duplicate. This has been brought about by the need of having any body fit the car that for the

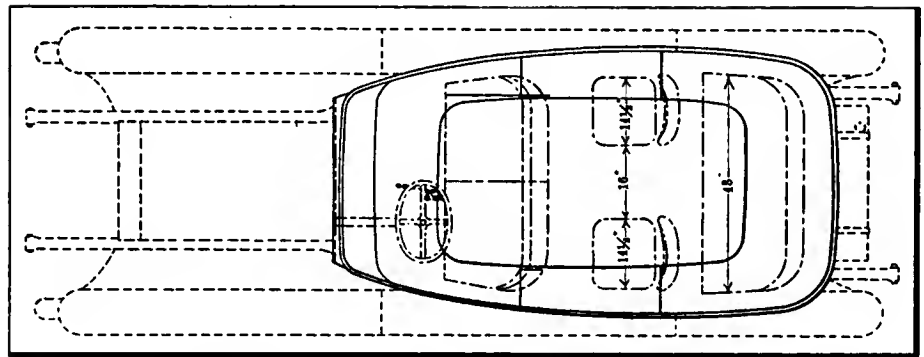

Fig. 3—Plan view showing the roomy arrangement of seats and location of steering wheel

time is in commission, and as during the early Winter and late Spring season the bodies for both Summer and Winter use are liable to be wanted, the feature of having any body fit any chassis helps to facilitate the smoothness of the running of things.

**CYLINDERS REQUIRE REBORING**—The metal in the cylinder walls is too soft to stand continuous service. Designers desiring, in the first place, to have the weight efficiency as high as possible take advantage of the fact that white metal is dense, hard and strong. Gray iron, on the other hand, is soft and is likely to be of varying texture. White metal in a cylinder is induced by so regulating the charge that it will take on the property technically known as "chill." This "chill" is not to a great depth in good cylinder metal, so that in order to preserve the white metal surface the finish must be restricted. It will be remembered that all finished metal is machined off, and what is wanted in completed cylinders is just enough finish to permit of making a smooth bore without cutting through the white metal coating into the gray iron texture. In the primary design of the cylinder a re-boring factor is always allowed if the bore of the motor is above 3 inches.

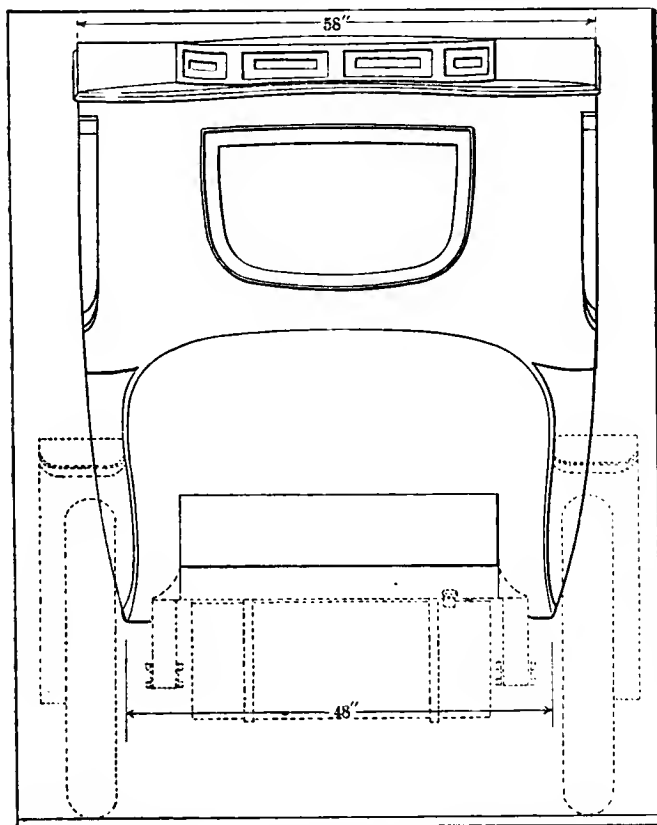

Fig. 4—Rear elevation of the new single-compartment limousine body, showing trunk

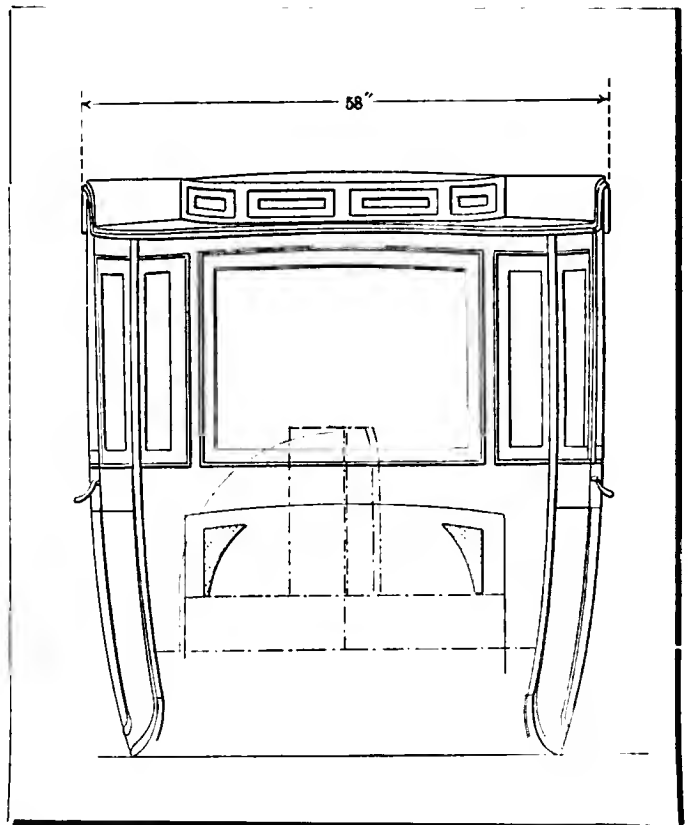

Fig. 5—Front elevation of limousine showing screen ventilators at either side of bonnet



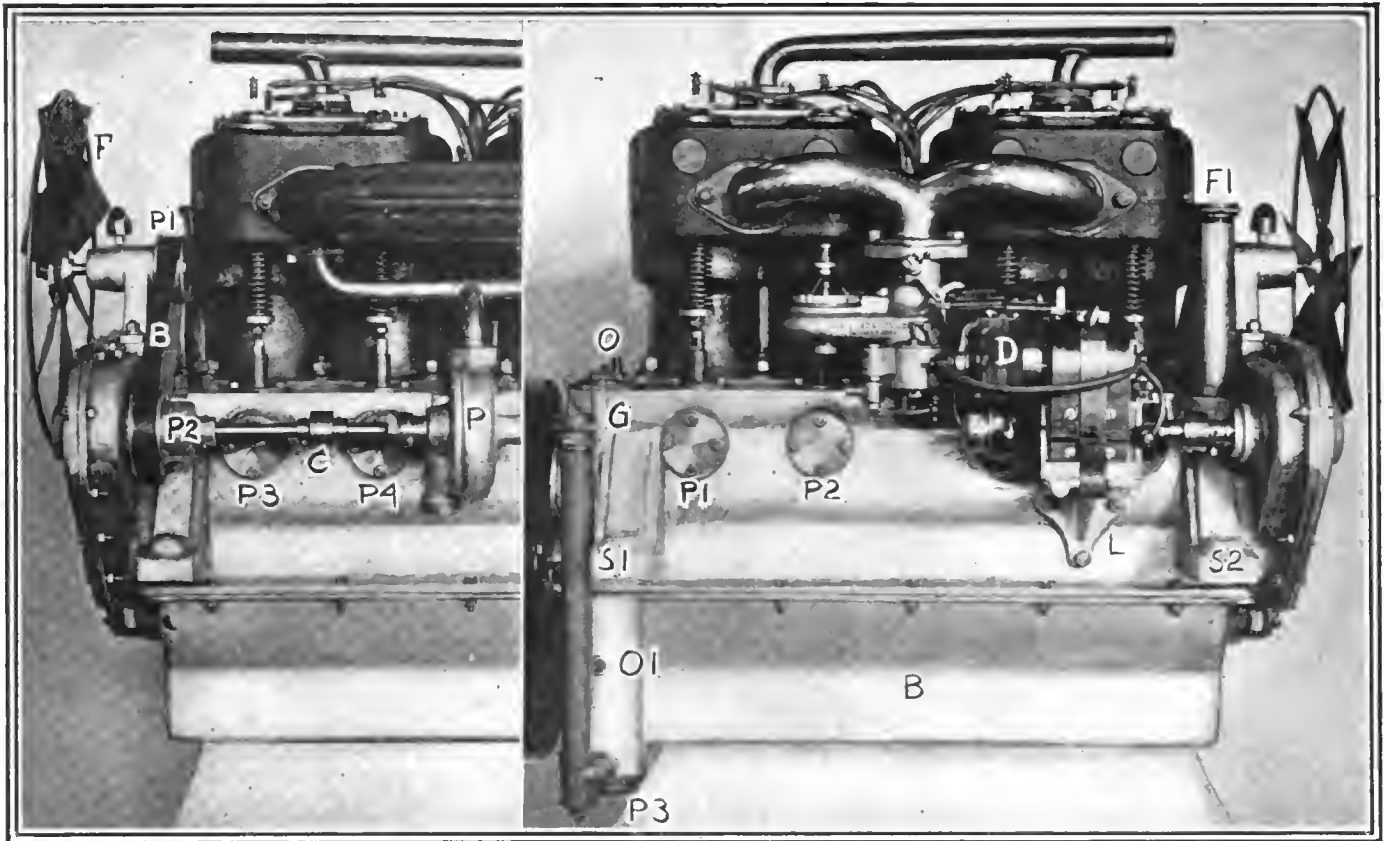

Fig. 1—Part of exhaust side of the Mercer motor

Fig. 2—Intake side of motor, showing the carbureter and double distributor magneto

## Mercer Thirty-five in Detail

THE leader of the coming season's line of Mercer cars, which are manufactured in Trenton, N. J., will be the 35-horsepower model. The motor of this model is shown in Figs. 1 and 2. Fig. 2 shows the intake side of the motor,

which is of the four-cylinder, four-cycle type, with cylinders cast in pairs. The valves are located on either side of the motor, the cylinders being cast with T-heads. The diameter of the intake valve is 2 inches, and the seat is given an angle of 45 degrees. The valves have a lift of 7-16 inch, and the valve setting can be seen by referring to Fig. 7. The motor has a bore of 4.3-8 inches and a stroke of 5 inches.

The ignition is furnished to two independent sets of spark plugs from a magneto with a double distributor, whereby two sparks take place simultaneously in the firing cylinder. Fig. 2 shows the magneto in position, resting upon a ledge L which is attached to the upper half of the base chamber by three bolts.

The carbureter is of the float-feed, constant-level type, bolted to a flange of a bifurcated intake manifold; the air adjustment has been simplified so as to give a separate adjustment for high and low speeds. Fig. 2 also shows the two arms S1 and S2, which rest on and are bolted to a sub-frame of the main chassis. Oil is poured into the base chamber through the large vent pipe FI and the level of the oil in the base chamber can be read upon the gauge G.

The water cooling is taken care of by means of a cellular radiator placed in front of the motor supported on ball trunnions, whence the water is delivered to the centrifugal pump P and thence to the base of the exhaust valve chambers. In order to render the dismantling of the pump as easy as possible, an Oldham coupling C is interposed between the shaft attached to the half-time gears and the pump shaft. An aluminum pulley P2 is attached by means of a taper pin to the pump-driving shaft and the fan F is driven by a flat belt B through the pulley PI.

The plates P3 and P4 carry the lever arms which are interposed between the cams and the valve pushrods. Referring to Fig. 14, the internal arrangements to operate the valves may be seen. The arms of the plate PI carry the pivot pin A1 upon which the arm A2 reciprocates. The lower part of the slipper

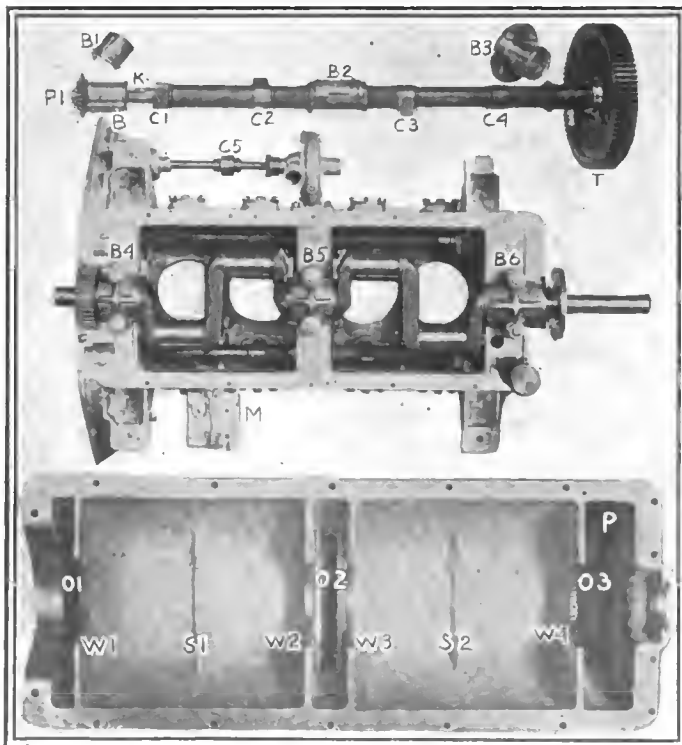

Fig. 3—Showing the base chamber and its components

S3 rides the cam, and the part S4 contacts with the pushrod R1. This is fitted at its upper extremity with a means of adjusting the lift of the valves, and in order to maintain the rod R1 stationary for this operation, flats are cut upon it at F. The nuts N1 and N2 form the adjustment.

Fig. 6 shows the method employed in securing the connecting rod to the hollow wrist pin. The connecting rod is made in the shape of an H instead of the conventional I-section, as may be seen from Fig. 14, which also shows the piston P, which is fitted with four concentric rings, all placed at the upper extremity. The lower part of the piston has a clearance between it and the cylinder of 0.008 of an inch, while the part situated above the top ring is given a clearance of 0.015 of an inch.

The crankshaft is carried on three main bearings, B4, B5 and B6, shown in Fig. 3, the lower caps of the bearings being held in position by 12-inch bolts which pass through the upper half of the base chamber. The timing gear T attached to the camshaft has a 1 1/4-inch face, the teeth being cut with a shaper. The camshaft is stamped integral with the cams C1, C2, C3, C4 from 7 per cent. carbon steel, which is annealed and hardened, the cams being ground to size. It runs on three main bearings B1, B2, B3 and the rear extremity is fitted with a key K which engages the collar carrying the pinion P1. The bearings B1 and B2 are split and lined with anti-friction metal.

The oiling system of the Mercer car has been carefully thought out and has been found to be most efficacious. In short, it is a combination of pump-feed and splash. Fig. 3 shows the lower half of the base-chamber, in which there are two compartments subdivided by the separators S1 and S2, forming troughs into which the lower half of the connecting rods dip. The oil that is carried in the sump shown at O1,

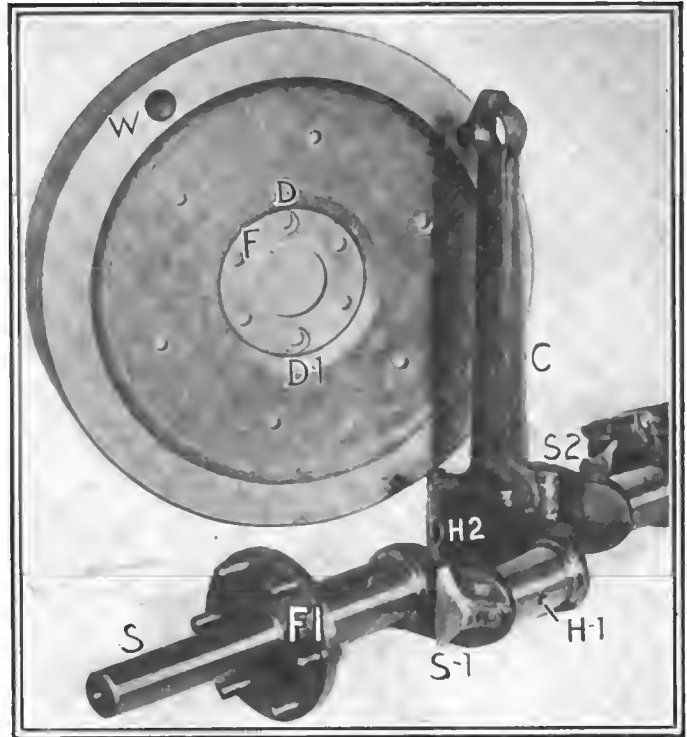

Fig. 5—Showing part of the crankshaft, together with oil cups and flywheel O2 and O3, extending the whole length of the base-chamber, is taken by a pump and delivered to the three main bearings

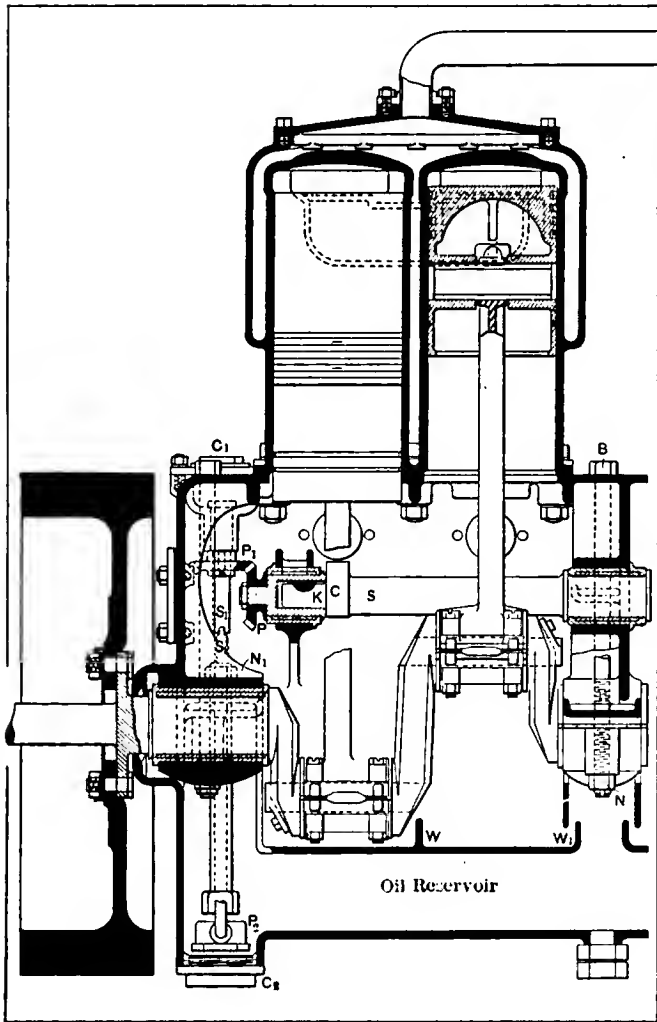

Fig. 4—Section of two rear cylinders, showing cam and crankshafts

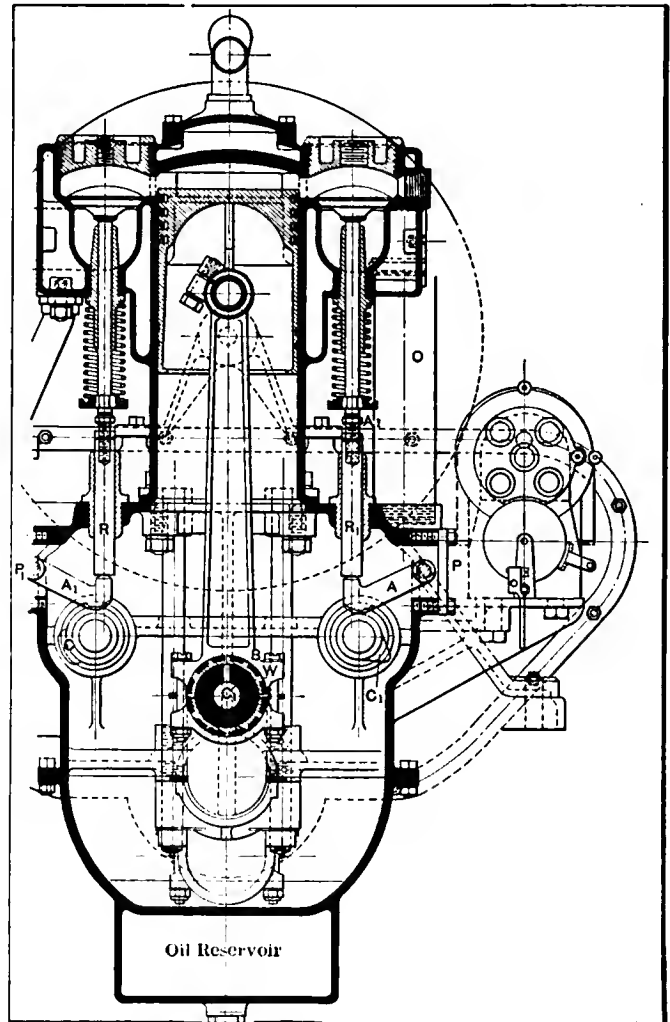

Fig. 6—Transverse section of the third cylinder of the motor

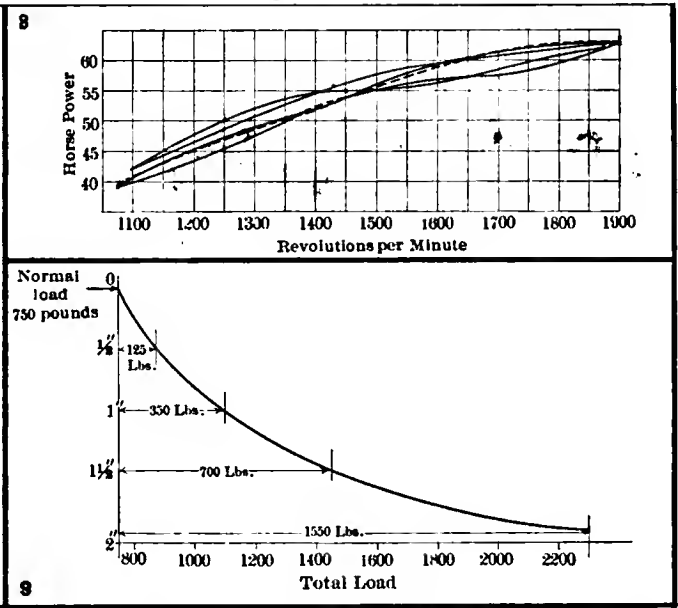
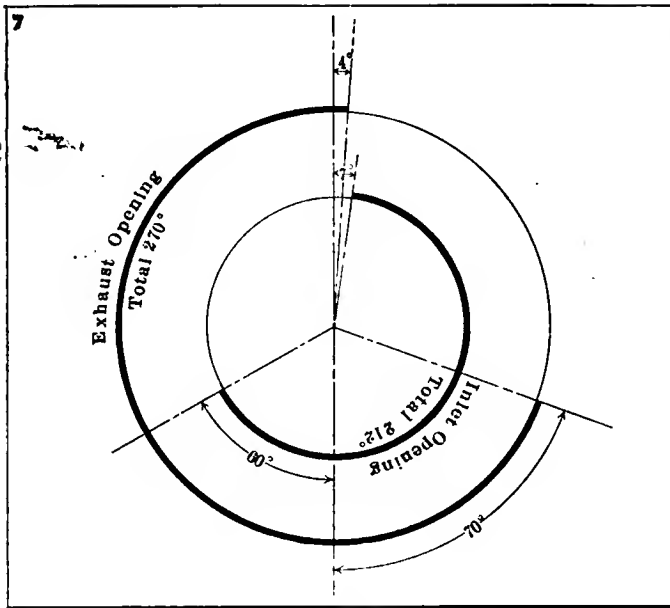

Fig. 7—Timing diagram of the Mercer motor, showing valve openings.

Fig. 8—Horsepower curves of five Mercer motors taken indiscriminately.  
Fig. 9—Chart showing deflection of the rear springs of the Mercer "35"

of the motor. As the crankpins are drilled hollow, as shown at H2 in Fig. 5, the oil that is delivered to the main bearings is thrown out of the extremities of the bearings by centrifugal force into the cups S1 and S2. The oil then passes through the hollow crankshaft out into the big-end connecting rod bearings by the hole H1. The shims that are interposed between the two halves of the big-end bearings are wide enough to allow of sufficient gap between the upper and

lower caps. The connecting rods strike into the oil in the troughs beneath them, thereby lubricating the cylinders, pistons and wristpins, as well as the camshaft bearings. As soon as the oil in these troughs reaches a certain level it overflows into the sump.

The details of the pump may be seen by referring to Fig. 10. The cap C is bolted into the upper half of the base-chamber and carries the shaft to which the bevel pinion P1 is attached. This meshes with a pinion P2, which is attached to the exhaust camshaft in the manner shown in Fig. 3. The shaft S has a slot cut in it in order to accommodate the tongue T3, which is integral with the shaft S1. The lower extremity of the shaft also has a slot cut in it, T2, in which the U-piece R slides. The pin P on the cap C1, placed slightly eccentric thereto, is placed in the hollow of the U-piece R, and as the shaft S1 rotates inside of the body B1 the part R carries the oil that enters at I and forces it out of the exit O. The general assembly of the pump is shown at the left, a gauze screen S encircling the base of the pump, thereby filtering the oil and preventing impurities from being returned into the circulation.

An auxiliary oil tank is provided and oil is delivered to the base-chamber by means of a hand pump when required. On the dash is a sight-feed through which the oil from the pump passes to the bearings. This is of such construction that the flow may readily be seen.

A new design of gearset is being incorporated in next season's models, in which the clutch and gears are housed in the same aluminum casting, located amidships and bolted to the extension of the subframe that carries the motor. The clutch is of the multiple-disc type and the service brake, which is located at the rear of the transmission, has a diameter of 10 inches and a width of 3 inches. The friction surfaces are cast-iron shoes

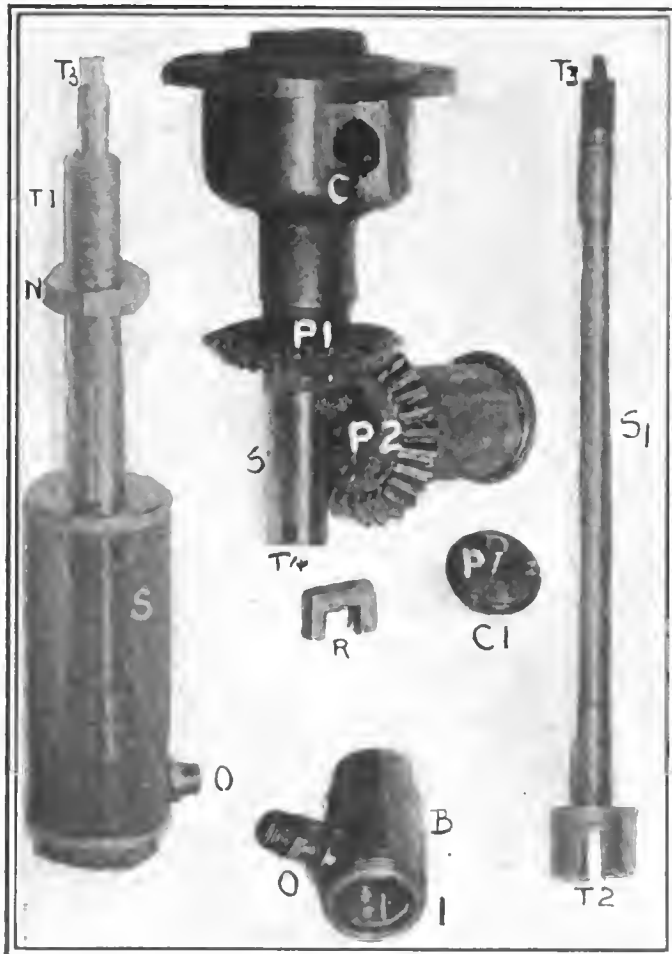

Fig. 10—Complete and detail assembly of the oil pump

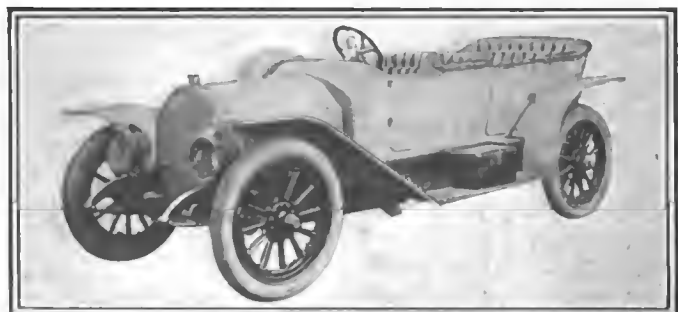

Fig. 11—General appearance of the Mercer fore-door torpedo

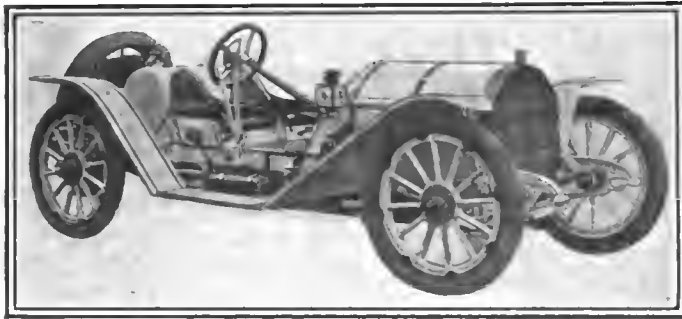

Fig. 12—Mercer raceabout, showing method of carrying gasoline tank and tires

to the steel drum. Three speeds forward and one reverse are furnished on the raceabout and runabout while four speeds forward and one reverse are fitted in the case of the four or five-passenger cars.

The general scheme of the live rear axle may be seen by referring to Fig. 12. The housing is formed by two pressed steel members welded together and the tubes T, which carry the weight of the load, are swedged into the main body and afterward riveted as an extra security. The shaft S, which is connected to the propeller shaft by means of a universal joint, is carried on two annular ball bearings and the end thrust is taken care of by the thrust bearings T2 and T3. The housing H1, to which the crown wheel is bolted, is carried on annular ball bearings, side-thrust bearings being employed as well. A torque member is attached at T1, which is part of the front end of the casing.

The rear cover of the differential casing is removable and after the live rear axle shafts have been sufficiently withdrawn it is possible to remove the differential unit. The wheel hubs are fitted with two annular ball bearings which slip over the tube T and are locked in position by means of the ring R, and the dogs at the ends of the shafts fit into corresponding slots in the hub. The driving member is attached to the ends of the shafts upon four keyways cut therein, but the ends that fit into the differential body are squared. The interior of the emergency brake may also be seen in Fig. 12. The drum is 14 inches in diameter, 2 inches wide, the shoes being faced with asbestos fabric liners.

The suspension of the raceabout and runabout is taken of

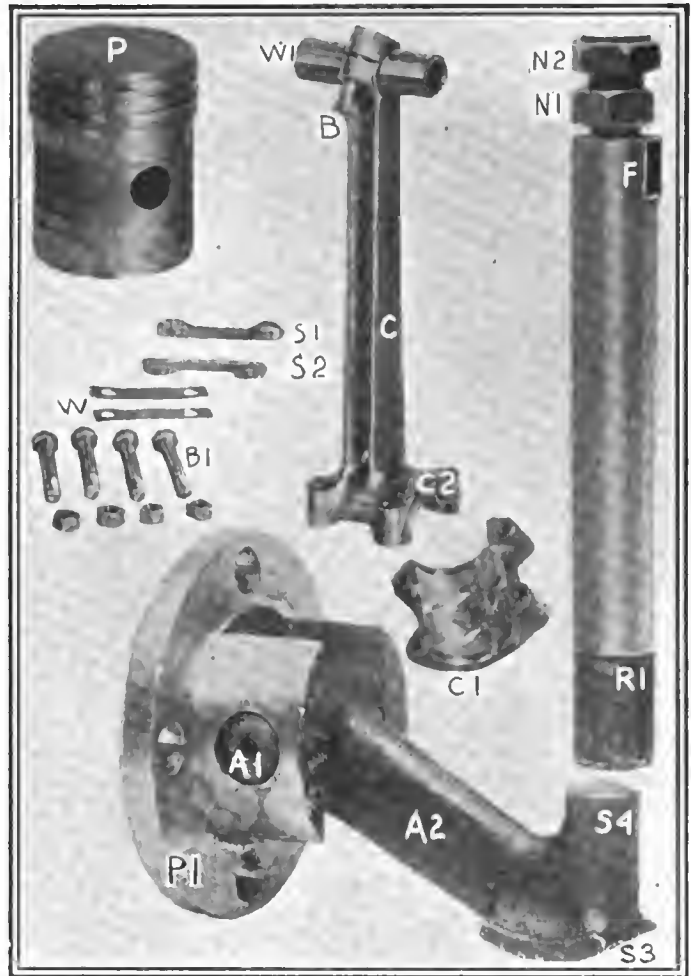

Fig. 14—Showing the piston-connecting rod assembly, also valve operating parts

semi-elliptic springs all around, but the touring cars have three-quarter-elliptic springs at the rear. Fig. 9 shows the degrees of deflection of the springs for various loads, and it will be seen that as the weight increases the deflection decreases.

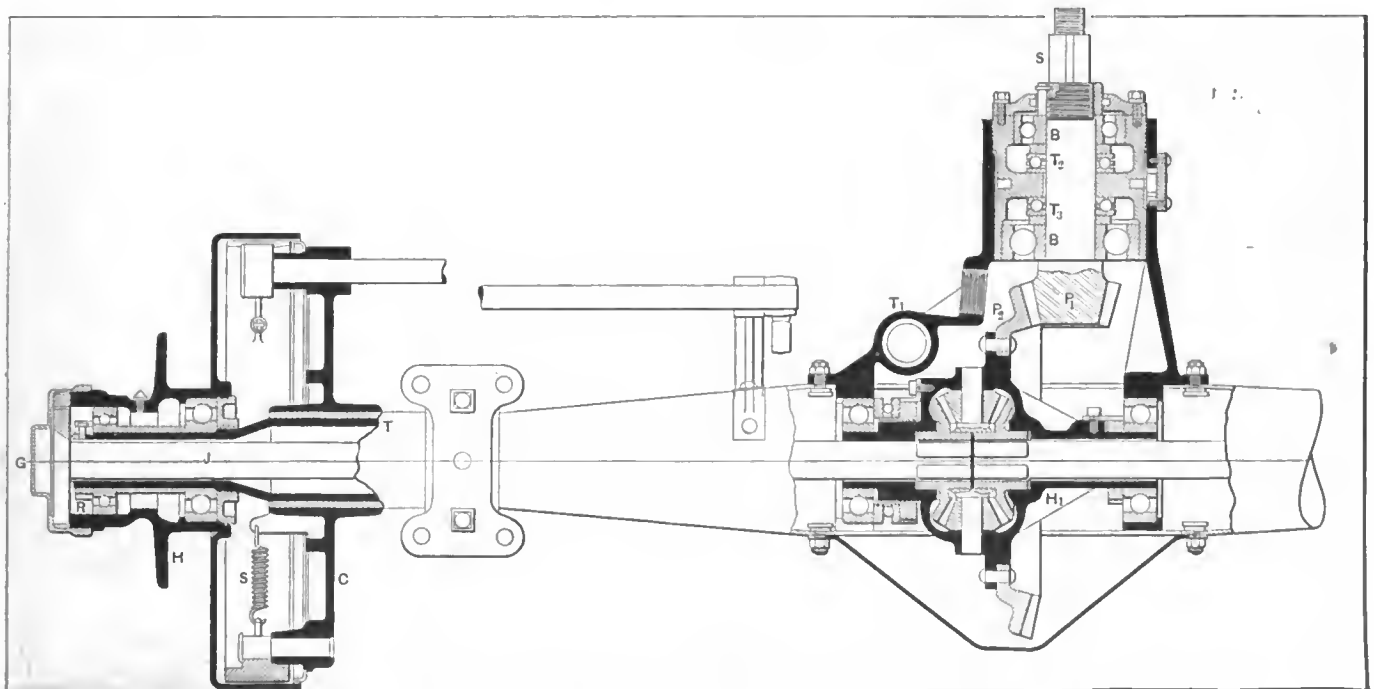

Fig. 13—Sectional view through rear axle, showing differential, driving wheel and driving shaft ball-bearing supports

# Letters Answered and Discussed

## Measuring Compression

EDITOR THE AUTOMOBILE:

[2,832]—As a subscriber to your valued paper I am taking the liberty of asking you a question in regard to the measuring of the compression of a motor. I have tried in vain to estimate it by various means and have not obtained satisfactory results. You would be doing me a great favor if you would let me know if there is any accurate means of measurement and, if there is, how it is done.

Oakdale, Cal. JAS. CARLTON.

The compression may be accurately measured by attaching a gauge as shown in Fig. 1. The spark plug is removed and the gauge screwed in position. The engine is then turned up slowly against compression and the pressure noted. Cold compression as determined in this manner will be slightly different from the running compression, as the pressure in the cylinder will not be atmospheric when the engine is operating with fuel.

## Believes in Accessibility

EDITOR THE AUTOMOBILE:

[2,833]—I have just been reading your editorial on the subject of accessibility and an accessibility contest, and I heartily agree with everything you have said. As I understand, and believe, automobiles are and must be for the people and general use, and therefore, unless they are to be run and thrown away at the end of each year (and such a condition of affairs is quite impossible), every owner must expect to overhaul his car about once a year.

The question then is, Are the wearing parts so put together that they can be replaced as conveniently as possible? If not, then unnecessary expense and loss of time must be the part of the automobilist.

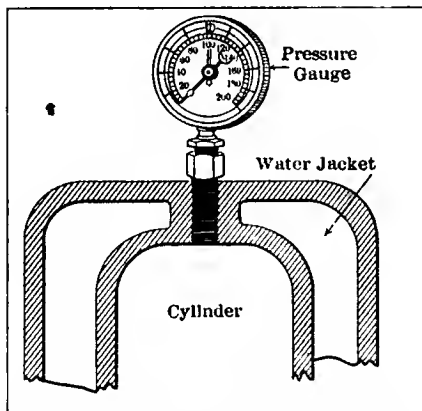

Fig. 1—Manner of inserting the pressure gauge in spark-plug hole to measure compression

*The Editor invites subscribers to communicate their automobile troubles and personal experiences, stating them clearly on one side of the paper. If the nature of the case permits, send a sketch, even if it be rough, in order to assist to a clearer understanding. Each communication will receive attention in the order of its receipt, if the writer's signature and address accompany it as an evidence of good faith. If the writer objects to the publication of his name, he may add a nom de plume.*



Besides this there are many adjustments which must, for one cause or another, be made on the road.

I also agree with you regarding designing engineers. If a yearly contest was had in which they, personally, were to drive, adjust and repair over a route, say, one thousand miles long, it would show them the error of their ways in hundreds of cases, and might, if they were willing to

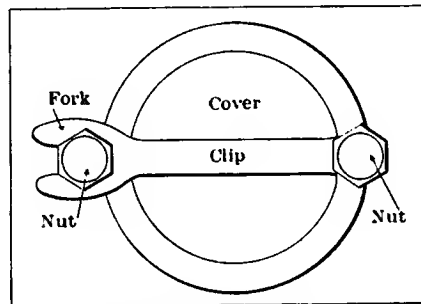

Fig. 2—Clip placed over screw cap to prevent it from falling off when subjected to vibration

accept the suggestions, result in making many cars what they should be, at little, if any, increase in cost.

It seems to the writer that the leading ideas for a designer should be suggested by the initials D. A. R., viz.: Durability, Accessibility, Reliability. I further believe that if the manufacturers of automobiles would send the users of their cars a set of questions regarding apparent faults and suggested improvements (as the publishers of several magazines have done), these answers (the result of natural and practical experience) would, if viewed in an intelligent and unbiased way, be of greater benefit to the manufacturer than any information he can get. Of course many answers and suggestions would be valueless for one good reason or another, but many would prove the way to great and lasting improvements. EXPERIENCE.

Kingston, N. Y.

The question of accessibility is now of timely interest and comments of this nature on the part of actual car users go a long way in showing the opinion prevailing and are therefore of exceptional interest.

## Holding Down Cap

EDITOR THE AUTOMOBILE:

[2,834]—I have a screw cap on the gasoline tank of my car which is continually jarring loose. After running about 50 or 60 miles the cover will fall off owing to the vibration of the car. Is there any way that you know of to remedy this? I would greatly appreciate an answer at an early date in your letter columns.

ED. MURPHY.

Mt. Vernon, N. Y.

A handy way of stopping trouble of this nature is to take a brass clip of the shape shown in Fig. 2. Two bolts are passed through the tank as shown and held by means of nuts on the inside and the outside of the tank. The clip is then placed over the bolts and another nut (preferably winged) placed over the top in such a manner that the clip is held tightly to the cap.

## Steering Knuckle

EDITOR THE AUTOMOBILE:

[2,835]—As a subscriber to your magazine I would like information on the following point: I recently saw a 1912 car of a prominent make on which the front axle, instead of being square with the floor on which the machine rested, was slightly inclined forward at the bottom so that the bottom bearing of the steering knuckle was very perceptibly in advance of the upper bearing. What is the reason for this? Will a car steer better if the knuckle is inclined that way than if it were perfectly plumb? R. O. BOGART.

Pluckamin, N. J.

A car will steer easiest when a line through the vertical center of the tires—that is, passing from the topmost point of the tire through the point of contact of tire and road—intersects at that point the line which is the continuation of the axis of the steering pivot. If these two lines intersect at some other point, or do not intersect at all, the steering will be harder. There is no gain in steering efficiency, so far as we are aware, in the suspension of which you speak.

## Variety of Information

EDITOR THE AUTOMOBILE:

[2,836]—As a subscriber to your paper I would like to ask the following questions:

(1) What is a triple-seat valve, such as is used on the "Blitzen-Benz"?

(2) What is the bore, stroke and horsepower of the car which won the Grand Prize in 1910?



(3) I have heard that a carbureter will work very well with a car of one make, while with another it will perform very poorly. If this is so, kindly tell me the reason.

SUBSCRIBER.

N. Y. City.

(1) A triple-seat valve is one in which the seat, instead of having one angle of seating, has three, which intersect each other at the valve seat.

(2) Bore, 155; stroke, 200 mm.; horsepower by American rating, 63; by makers' rating, 120.

(3) The different types of manifolds used on cars of different makes require a change of adjustment in the carbureter when it is shifted from one car to another. The carbureter itself should work just as well on one car as another provided it is of adequate size for either car. A large high-powered car will require a larger carbureter than that used on smaller motors.

### No Scoop Necessary

Editor THE AUTOMOBILE:

[2,837]—My motor is lubricated by means of the splash system—that is, the connecting rods dip into the oil. There is no scoop on the bottom of the rod and I am not sure that it has not been left off by mistake, as a friend of mine has a machine which is lubricated in the same manner and he has a sort of copper spoon on the part of the rod which splashes into the oil. Is this fitting necessary? I would esteem a reply through your columns a great favor.

CHAS. COFFEY.

Tarrytown, N. Y.

The scoop is not necessary, as there are several cars using the splash system which are without it. There is generally a hole in the bottom of the connecting rod in which the oil is caught up and thrown over the cylinder when the scoop is not fitted.

### Oil Leaks from Crankcase

Editor THE AUTOMOBILE:

[2,838]—My car has the oil reservoir in the base casting, and since there seems to be a space between the flanges of the two parts of the crankcase casting the oil leaks through and runs down the side of the base chamber. Would you kindly tell me how to stop the waste of oil? I do not mind the small amount of oil wasted so much as the dirty appearance of the motor on account of the leakage.

E. H. S.

Clarksville, Tenn.

Take out the bolts which hold the upper and lower parts of the crankcase together and with a V-chisel cut a groove along the flange to take the packing, as illustrated in Fig. 4.

The bolts are tightened up after the packing, consisting of lead wire, has been put in place. When the bolts are tightened the lead will be squeezed into the groove and effectually stop any leakage.

### Wedging Up Car

Editor THE AUTOMOBILE:

[2,839]—I have a very small car which I use for going about the country on business calls. Several times I have been obliged to stop on account of tire trouble and have been caught without a jack. The last time I tried to wedge the car off the ground, but found that the wedge would not slip along the rubber shoe. I have written you to find if there is any simple way of lifting the car without the aid of a jack.

TROUBLED.

Vandalia, Ill.

It seems in a case of this nature the best advice is to carry a jack, as such a tool is usually very small and compact. If it becomes necessary on some occasion to wedge the car from the ground, it is useless to attempt to drive a wedge beneath one of the wheels. Two wedges and a plank should be used as is shown in Fig. 3. The plank is laid upon the ground with one of the wedges upon it. The car is then run or pushed upon the plank and rolled up the wedge for a short distance. Before the car can roll back the other wedge is laid upon the first, between that and the wheel.

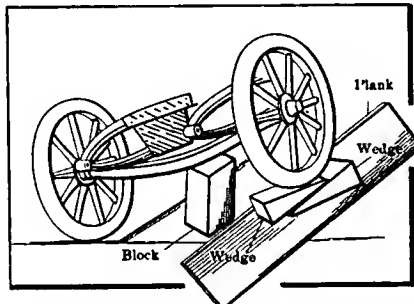

Fig. 3—Sketch showing the manner of placing wedges beneath wheels of automobile

The car will then take up the position shown in the illustration. The lower wedge may be driven in a little way to lift the wheel still higher. A block of wood is then inserted as shown and the wedges withdrawn to allow of the work being carried on. In lowering the car the wedges are replaced and hammered out gradually, thus allowing the car to be placed upon the ground without jar.

### "Waterlogged" Float

Editor THE AUTOMOBILE:

[2,840]—For some time I was very much troubled by getting too rich a mixture at low speeds. This trouble kept getting worse until finally the motor could not be operated at all without getting a cloud of smoke and a large amount of carbon deposit on the cylinder walls. After attempting to remedy the trouble by making various adjustments on the carbureter and grinding the needle valve, which I strongly suspected to be the source of trouble when I first started to examine it, I have come to the conclusion that the cork float is soaked

full of gasoline and has lost all its buoyancy.

How do you go about remedying a trouble of this nature? Is it necessary to buy a new float, or can I repair it at home? I have a garage which is very well fitted up with the various tools.

AMATEUR REPAIRMAN.

Bath, Me.

In a case of this nature it is not necessary to buy a new float or even send the carbureter out to be repaired, as it may be very easily fixed at home. The float is removed and placed in an oven which is not too hot, and allowed to remain there until thoroughly dried out. It is then removed and given a coat of shellac and one of thin varnish.

### Regarding Air Compressors

Editor THE AUTOMOBILE:

[2,841]—Would you kindly answer the following questions:

(1) What percentage of piston displacement will a 6-inch x 3-inch air compressor have if the compression space is ten cubic inches and the machine runs at 500, 1,000, 1,500, 2,000 and 3,000 revolutions per minute?

(2) What percentage of piston displacement with a 3-inch x 3-inch compressor having a port 3/8 inch x 4 1/2 inches opened by the piston at the bottom of the stroke, the air being drawn in through a 1 1/2-inch pipe 18 inches long, running at the same speeds as the above?

W. M. BAUMHECKLE.

Cincinnati, O.

(1) The compression space will be 23.6 per cent. of the piston displacement. The piston speed does not affect this quantity.

(2) In order to determine the percentage of the compression space the volume of the same must be known, or, in designing a compressor, the desired compression must be ascertained.

It is difficult to calculate the volume of the compression space in some instances owing to the pockets and irregular valve openings.

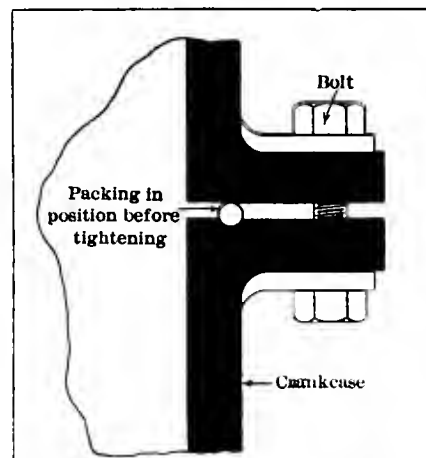

Fig. 4—How packing is placed to prevent leakage of oil from the crankcase

# My 1912 Automobile

## A Conception of What the Ideal Car Should Be

### EDITOR THE AUTOMOBILE:

My conception of an ideal automobile is as follows: Price \$2,500, fully equipped with top, glass front, two extra tires on demountable rims, either Dorian or Firestone Q. D., and with some kind of power pump for blowing up the tires.

The wheelbase should be 114 inches, with 56 inches tread and the car should comfortably seat five. The wheels should be 36 inches and the tires  $4\frac{1}{2}$  inches. Bearings should be roller for the wheels, babbitt for the engine and ball bearings in the transmission.

The transmission should give four forward speeds and reverse. The gear ratios should be approximately 12 to 1 on low and reverse; 7 to 1 on second; 4 to 1 on third and 3 to 1 on high. Direct gear should be on the third speed. This gearing, although very low for the third speed, would enable one to handle the car easily at slow speeds in the city, over the majority of roads and over hills without gear changing.

Steering should be by irreversible worm and sector gear.

Motor should be  $4\frac{1}{2}$  bore by 6-inch stroke, 4 cylinders T-shaped, cast separately, with  $2\frac{3}{4}$ -inch poppet valves, with lifts fixed so as to be adjustable.

Radiator should be on dash, with thermo-syphon system. This protects the radiator from strains and allows good water circulation without a pump. Radiator can be placed higher without interfering with view of driver. Fan should be bolted on flywheel edge. Hood should be of sloping type and it should be made practically dust-tight when closed.

The crankcase bottom should be removable without disturbing the crankshaft and all engine bearings should be then easily adjusted. The case should be tight so no dust could get

to the engine, thereby doing away with usually inaccessible dust-pans.

Brakes should all be contracting, emergency on wide drums on rear wheels and foot brake on a very wide drum on the propeller shaft, all to be designed to adjust readily without tools.

Clutch should be multiple disc running in oil; about 60 plates should be used.

Ignition by magneto arranged so that it also charges a storage battery which furnishes current for lights and for auxiliary system.

Carbureter should be best actuated by throttle on wheel and foot control also, while the needle valve or the auxiliary air valve should be adjustable from the driver's seat.

Weight of car would probably be about 3,000 lbs. Road clearance ought to be about one foot.

Springs ought to be long and limber, with straps and rubber bumpers to prevent spring breakage.

Lubrication should be by splash from oil trough, oil reservoir to be in crankcase base. Oil should circulate through two sight feeds on dash and should be by two pumps, so if one became disabled the car would still be properly lubricated.

The price of a car such as above described might be brought down to about \$2,200 and would give one an all-around car capable of going anywhere and easily handled in congested traffic.

A self-starting device similar to the one used by cars now on the market would be appreciated by the majority of people using machines.

MARTIN J. D. ALBERTSON.

Glen Head, N. Y.

## Harking Back a Decade

IN the issue of *The Motor Review*, September 19, 1901, the following items of interest to motordom appeared:

Secretary S. M. Butler, of the Automobile Club of America, has issued an order from the Board of Governors of the organization abandoning the scheduled Erie-Buffalo road race, the week of sports and the one-mile record race, all on account of the assassination of President McKinley.

Announcement is made that among the chauffeurs entered for a race meeting scheduled for October 10 at Providence, R. I., are the following: W. K. Vanderbilt, Jr., Foxhall Keene and Henri Fournier. Cups were offered for electric, steam and gasoline automobiles.

A big automobile show, to be held at the Coliseum, Chicago, under the auspices of the Chicago Automobile Club, has been given dates from March 1 to 8, 1902. The big West is thirsty for automobiles.

The projected automobile show at the Wisconsin Fair failed to materialize. The excuse is made that horses are an older institution than automobiles and consequently more popular.

The great Buffalo Endurance run, which started from New York with 79 entries, and was called off at Rochester after the shooting of President McKinley, was a great success. It was pointed out that 41 vehicles reached Rochester; thus only 38 fell out en route. The daily mileage was less than 80 and repairs and replacements within controls were allowed. Secretary Butler

followed the column from place to place by train so as to insure reaching the night controls.—*Editorial.*

"A foot-pound saved in transmission is a foot-pound earned at the motor. 'Just as good' and 'practically as efficient' are but excuses for the weakness of making things good enough, rather than as good as possible."—*Technical filler.*

Among those who drove cars in the Buffalo run were the following: Elmer Apperson, David Ferguson, R. H. White, Herbert H. Lytle, J. W. Packard, Percy Owen, S. D. Waldron, A. L. McMurtry, John Jacob Astor, A. L. Riker and C. W. Wridgway.

The floral parade at Cleveland proved to be an unqualified success. George S. Waite won first prize for the most artistic decoration. His car was covered with flowers, carnations on the wheels and gladiolas and carnations in the body. Six white pigeons ornamented the front of the car while the rear was a blaze of red, white and blue flowers.

An effort has been made by the Board of Trade of Middletown, Conn., to locate the Fisher Horseless Vehicle Company in that city. The company has been employing 300 men at Hoboken, N. J.

John Towns, of Hamilton, Ohio, has purchased an 8-seated automobile bus from the Haynes-Apperson Co., Kokomo, Ind.

The Century Motor Vehicle Company has shipped a two-seated surrey to Germany.

## Digest of Leading Engineering Papers

**M**ATERIALS for light-weight construction fall into two groups, those of extraordinary strength, particularly the chrome-nickel and the non-corrosive high-nickel alloy steels, and those of low specific gravity with the strength as high as obtainable. Where construction forms run to mass and rigidity, without severe alternating or local strains, those metals which are both lighter and stronger than aluminum are gaining a place for themselves. Electron, made by the Griesheim-Electron Chemical Works, has a specific gravity of 1.8 and a tensile strength up to 3,500 kg. per square centimeter. It is not yet patented in Germany, but the American patent, 965,485, July 26, 1910, gives the alloy as 80 to 99.5 per cent. magnesium and 0.5 to 20 per cent. aluminum and other metals. The principal method used for removing injurious salts from this alloy consists, according to other Griesheim patents, in melting the alloy together with an alkaline chlorid, or mixture of such, whose fusion point lies considerably higher than that of the pure alloy. In the cooling the chlorid thus congeals first, and the molten alloy can be drawn off. It is kept molten for some time, preferably isolated from the atmosphere, or a neutral gas, such as hydrogen, is injected in the molten mass, whereby the last remnant of the chlorid is evaporated. To avoid porosity in castings of aluminum-magnesium alloys a similar method is used, under German patent 228,962 (Class 31, c), October 1, 1909. It was found that the molten metal at about 700 deg. C. takes up hydrogen and does not throw it off till just before congealing. The hydrogen comes either from the hygroscopic salts referred to or from the water vapors of the fuel gases, the water vapor being split by the molten magnesium, making  $Mg + H_2O$  into  $MgO + H_2$ . To remove the gas completely, the metal is kept for some time at the temperature at which the gas is thrown out, which is only a few degrees above the melting point of magnesium, and this may be done while the metal is in the crucible or after it is in the mold. The gas escapes in bubbles, leaving a perfectly dense alloy.

The French patent, No. 407,814, with supplementary patent No. 11,905, gives the method of Walter Ruebel for producing a magnesium alloy. Zinc or copper and zinc or copper and aluminum are the admixtures used for binding the magnesium and obviating the many chemical reactions to which it is subject in its pure form. An alloy of 96 per cent. magnesium and 4 per cent. zinc has a tensile strength of 1,500 to 2,000 kg. per square centimeter, but rolled the same alloy reaches 2,500 to 3,500 kg. tensile strength and an elongation of 8 to 12 per cent. The zinc may be increased to 10 per cent. without reducing these figures, or 6 per cent. copper and 4 per cent. zinc may be used, or 9 per cent. copper and 1 per cent. of aluminum. The magnesium, however, must not fall below 90 per cent. or exceed 96 per cent. The production takes place in a wrought iron crucible, well covered, and in an ordinary coal fire. The zinc is added as soon as the magnesium melts and is absorbed at once. If copper pieces are added, they also melt at once despite the much higher fusion point of copper.

The oxidation in pouring is slight and the casting shows a perfectly smooth surface. It can be forged and rolled and does not tarnish in air or water. It can be machined like brass or bronze.

A similar alloy, made by Basse & Selve, in Altona, Germany, with a specific gravity of 2 when cast gives a tensile strength of 1,200 to 1,500 kg., but when drawn has a density of only 1.772 to 1.780, but a strength of 2,700 to 3,000 kg. A British-made alloy, known as cork-metal, is composed of magnesium with only 0.5 per cent. zinc, and its specific gravity is 1.762. Very recently the French firm, Esnault-Pelterie, of Billancourt, has obtained

German patent No. 230,995 for an alloy composed of 80 to 85 per cent. aluminum, 5 to 10 per cent. of silver or another precious metal and 5 to 15 per cent. of a metal belonging to the iron group, such as cobalt, chromium, nickel or manganese. The silver has the effect of preventing the segregate crystallizing of the other metals, and a tough alloy is the result. In the production, the silver and the chosen metal of the iron group are first separately melted, then mixed in the desired proportion, and the mixture is then added to the molten aluminum.

The Ferro-Nickel company of Paris holds German patent No. 231,060 on a composition of 94 to 98 per cent. aluminum, 1.5 to 4 per cent. copper, 0.25 to 1.25 per cent. manganese and 0.25 to 1.25 per cent. silver. The total of the three admixtures must be between 2 and 6 per cent. These alloys can be drawn, stamped, forged and rolled, both cold and hot, and reach 2,800 kg. tensile strength per square centimeter with 1,400 elastic limit and 16 per cent. elongation in rolled and annealed strips 1 mm. thick. Rolled but not annealed, the tensile strength rises to 3,700 kg., but the elongation drops to 1 to 2 per cent.—Dr.-Ing. A. Sander in *Dinglers Polytechnisches Journal*, August 19.

**QUALITY TEST FOR FINISHED STEEL AND METAL PARTS.**—As the strength and other important qualities of an article made from steel depends to a considerable extent upon its shape and dimensions, if it has been subjected to heat treatment as well as in the case of castings, tensile tests applied to standard test pieces are not always available or practicable, and at all events they would not answer the question which is frequently the most important and which relates to the strength or hardness and resiliency in various portions of the same article. In this respect the method for determining hardness by indenting the article at various points of its surface by means of a steel ball of given diameter to which a given amount of pressure is applied and then measuring the indentations, has evident advantages. These the author has investigated through a series of experiments. He finds that the different portions of the same article usually show considerable variations under the ball-pressure test, but that the variations which should be ascribed to uncertainties in the testing method represent less than 10 per cent. of the variations which are actually existent in the tested article, provided proper scientific precautions are observed, and that the method therefore possesses a genuine value. It was found that the indentations are always accompanied by a conical rise or swelling of the adjacent metal and that the rapidity with which pressure is applied affects the result considerably, rendering it necessary to establish a uniform and slow action of the pressure levers for purposes of comparison. Other matters which were considered in the experiments related to the shape of the surface at the spot where pressure was applied and the direction of the "grain" of the metal, as determined by rolling or forging. No mention is made of the scleroscope, in the use of which the rebound of a steel ball allowed to drop from a certain height upon the article to be tested is measured in order to determine hardness and resiliency.—Capitaine Grard in *La Technique Moderne*, June and July.

**THE WHIP AS AN ACCESSORY.**—In Germany the whip is becoming an accessory for automobile tourists, according to *Allgemeine Automobile Zeitung*. It has been found that cows, though they refuse to get out of the road in front of an automobile until bumped into, respond at once to the persuasion of a whip, and an enterprising firm has consequently placed an automobile whip in the market. It is of such dimensions that it can conveniently be put away under the seat until there is need for its services.

# Little Bits of Motor Wisdom

## Pertinent Pointers for Repairman and Driver

**THE FACE SPANNER**—It very often happens that a screw cover is placed in such a position that it is impossible to have a projecting nut on the outside of the cap. In this case the difficulty is generally surmounted by having a face plate cover in which there are two holes to take corresponding projections on the face spanner. The face spanner and the cover plate are illustrated in Fig. 1. In making this type of cover a depth will have to be allowed that will permit of the insertion of

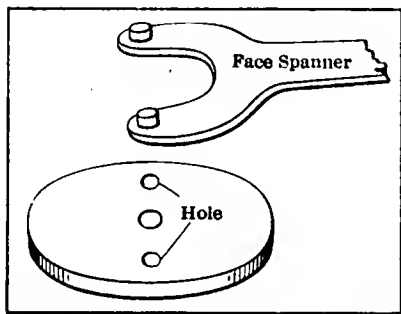

Fig. 1—Face spanner and face nut, showing holes in nut and projections on spanner

the wrench, for if the holes are too shallow it will not take much of a pull to tear them so that the cover will be worthless. Another method of making this type of spanner is to have it arranged so that it will fit around the cover plate, with a projection on the inner edge of the curve to fit into the corresponding hole in the disc.

A tool of this nature is generally sent with a piece of machinery in which there are nuts of this type, but in case it is ever necessary to turn them and the wrench is not accessible it is very easy to do it by hammering upon the slots. A piece of hard wood should be placed against the hole and the end can be hit with a hammer or mallet. The object of using the hard wood is that the use of metal would be injurious to the edge of the hole and hence the next time the wrench was called into service it would slip out.

**THE INDUCTION COIL.**—When the high-tension system of ignition is used with dry batteries an induction coil is used to transform the low-tension current of the batteries to the high-tension current which must be sent to the spark plug in order to jump the gap between the sparking points. The low-tension make-and-break ignition is effected by the electric arc described when two points break contact. The high-tension current, however, owing to its high

pressure, will jump across a gap to complete its circuit.

The coil consists primarily of a soft iron core which is wound with coarse wire, this winding being placed around the tube which insulates the core. This winding is known as the primary winding and it is to this wire that the batteries are connected. The various turns of the primary or battery coil are insulated so that they are never in contact with each other.

After the primary coil has been wound about the core the secondary coil is placed about it. The secondary coil consists of very fine wire with a great number of turns, each insulated from the other in the same manner as the primary coil, great care being taken that there shall be no electrical connection between the primary and secondary windings. The greater the number of turns on the secondary coil, the greater the electromotive force produced by the coil, and naturally the higher the price of the coil.

The ends of the primary wire are led to the outer casing of the box in which the coil is always packed, one end being attached to a binding post, while the other is connected to the current interrupter, generally known as the vibrator or trembler, and then to a binding post. The ends of the secondary winding are attached to binding posts on the coil box, one fastening being made to the same binding post as that to which the end of the primary

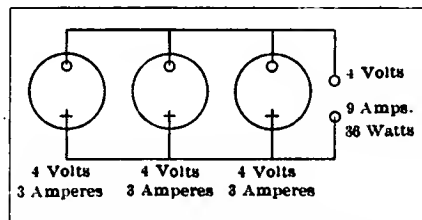

Fig. 2—Showing voltage and amperage at the terminals when connected in parallel

wire was attached, while the other is connected to a separate binding post. In coils not intended for ignition purposes the terminal of each winding has a separate binding post.

The battery is connected to the primary coil in such a way that the flow of the current is through the coil, trembler and back to the battery through a ground connection made to the engine frame. The trembler is a thin flat piece of metal which is held away from the core of the primary winding by means of a weak spring. At the other end of the flat trembler there is a

fixed connection with the ground and a contact point with the primary winding, which is fixed as long as the trembler is in its normal position. When it is moved so that the contact points do not touch each other there is no electrical connection between the ground and the primary winding, or, in other words, the primary or battery circuit is broken. When the switch is closed a current passes from the battery through the primary coil, magnetizing the soft iron core. This magnetism draws the trembler to the core against the resistance of the weak spring, but in drawing the trembler towards the core the circuit is broken and the soft iron loses its magnetism, allowing the vibrator to return by means of the spring to its original position. The circuit is then closed again and the core remagnetized, whereupon the interruption of current again takes place and the trembler flies back into its original position, going through the same process repeatedly. These actions and reactions take place so rapidly that when the tension on the vibrator spring is properly adjusted a continuous humming sound caused by the vibration of the metal may be heard. The sound forms a means by which the practiced ear can distinguish the correct and incorrect trembler adjustments.

Each time the current through the primary winding is interrupted a counter-current of high voltage is induced in the secondary winding. The secondary winding is connected to the ground and to the spark plug, which is so constructed as to take the ground current and the direct wire without short-circuiting. The high-tension current thus induced leaps the gap between the points of the spark plug and produces a spark. Since the number of vibrations (and hence interruptions of the primary circuit) is so great, the high-tension current is likewise interrupted at the same speed and with the same frequency, so that instead of a single spark being sent across the gap in the sparkplug a continuous stream of fire is passing between these points, producing a hot and effective form of ignition.

In order that the sparks will not be continuously passing between the sparking points in the plug at the wrong time, a timer is inserted in the line, which switches the current to the cylinder at which it is needed at any given time. The timer is driven directly from the engine and may be advanced or retarded on its shaft from the driver's seat to correspond to the different positions of the throttle.

**VOLTAGE AT BATTERY TERMINALS.**—Up to a certain point, which is measured by the magnetic capacity of the soft iron core of the induction coil, the spark in a high-tension system will increase with the voltage sent through the primary coil. When the batteries are attached in serial form as shown in Fig. 3, where three batteries are connected for the purpose of illustration, the total voltage amounts to 12, while the amperage is 3. That is, where the batteries are connected in this manner, the effect is that of adding the voltage of each until the total at the terminals is equal to the sum of the voltage of all the batteries. In the case taken for illustration each battery had a capacity of 4 volts, so that at the terminals the electro-motive force was equal to 12 volts.

In connecting in series, the carbon point of each cell is connected to the zinc of the succeeding battery until the batteries are all joined together, leaving a carbon terminal free at one end of the chain and a zinc at the other. It is not true that when additional batteries are put on the circuit in connecting in this manner that the current is increased in the same proportion as the number of cells, but when used with the high external resistance given by an induction coil, the increase is very nearly proportional to the increase in the number of cells.

When connecting in parallel, as shown in Fig. 2, the current given off is just about equal in voltage to one battery if the external resistance of the circuit is high, while the amperage is equal to the sum of that of all the batteries. The watts in both cases are the same, 36, being, of course, the product of the voltage and amperage.

**NECESSARY TO WATCH BEARINGS.**—Whether the bearings be roller, ball or plain they are without doubt the most necessary parts of the car to watch. Every car owner or driver should know, after he has had his automobile for even a short time, the location of every bearing throughout the car. The symptoms of bearing trouble are always very evident, but the mere fact of their prominence suggests that they come when it is generally too late to avoid trouble.

When traveling along smoothly a grinding or grating noise of somewhat mysterious origin will sometimes make itself heard to the driver. The car will continue to run smoothly for a while until the grinding noise is followed by a breakdown which will nearly always be beyond the scope of roadside repairs. The general symptoms of bearing trouble are a grinding sound or in plain bearings a squeak, the latter generally being accompanied by heat. In other parts of the car there will be an excessive side play and a variation in the tightness of adjustment between one side of the bearing and the other. A plain bearing which has been allowed to become superheated will often seize.

The principal enemy of any bearing, if it has the proper care so far as lubrication is concerned, is grit. Grit will often be carried into a bearing by the lubricating oil, so that it is necessary in the first place to ascertain that the oil which is used for lubrication is of such quality that it is reasonably sure to be clean. To prevent the collection of grit, the bearings should be occasionally taken down and cleaned out. At these times the adjustment should be carefully examined and an excessive amount of play not allowed. Too tight an adjustment of any bearing is as serious a fault as too loose, as the oil will not be able to prevent the bearing from overheating on account of the increased friction. Ball bearings should be frequently examined for wear, since when the adjustment becomes loose the chances of the balls being fractured are greatly enhanced. A slight amount of wear can be taken up on the adjustment of the bearing, but where it is excessive the balls should be replaced at once.

Roller bearings give evidence of wear by a rattling noise which gradually increases as the wear becomes greater and the rollers are fractured. If taken down the rollers which are affected by the wear will be noticed to have grooves which have been worn into them. Roller bearings, like ball bearings, are very seriously affected by grit, and it is very necessary that they be examined occasionally in order to ascertain if they are perfectly clean.

If a bearing runs hot while on the road and the driver is fortunate or skilful enough to detect it before seizure or serious damage occurs, the car should be stopped and allowed to stand while the bearing is cooling. The cooling should not be hurried by pouring cold water on the heated metal, as the result is very liable to be disastrous to either the shaft or bushing. A limited

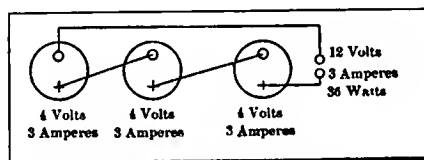

Fig. 3—Showing voltage and amperage when connecting batteries in series

amount of oil may be poured on the warm bearing if it is desired to cool quickly, but even this practice is not as good as to allow the bearing to cool slowly.

If a ball bearing should fail through the breakage of one of the balls it is necessary to stop and carefully remove every piece of broken metal from the ball race, for if this is not done the other balls will be ground to pieces after having run for a very short distance. The ball should be replaced by one which is exactly the same size. If too large a ball is used the results would be much worse than if the car were run on a bearing which consisted of one ball less than the original number.

**WHEN HEATING GLUE.**—The purposes for which glue is used are so numerous that it is often called into service around the garage as well as in other work. It requires heating after it has stood for any length of time, so that it is often necessary to wait until it is sufficiently heated in an uncovered water pot, since the glue cannot well be placed directly upon the fire. There is a form of glue pot which is much used among wood workers which would be a handy adjunct to the outfit of any garage where repair jobs are done. It is illustrated in Fig. 4, and consists of two

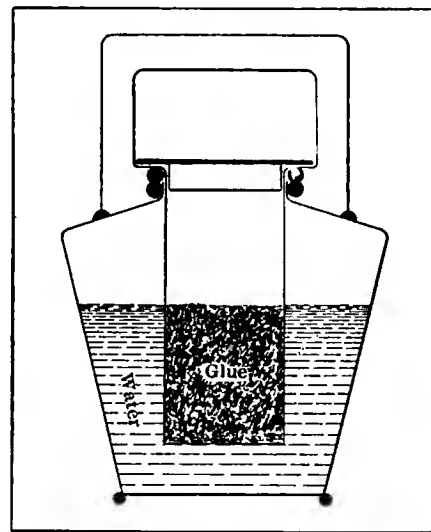

Fig. 4—Form of glue pot often used among wood workers. Adaptable to garage work

pots, an inner and an outer, which fit together.

The outer pot contains water while the inner fits directly into it, being supported by the top as shown. Since the inner pot is suspended in this manner the water is free to circulate about it and when placed upon the stove all the heat will be concentrated upon the glue in the inner pot. The cover prevents the escape of vapor from either the water or the glue pot, thus doing away with the unpleasant odor which generally accompanies the process of heating glue. The glue will be kept warm for a longer period of time, as the heat will be contained within the closed vessel instead of being given off to the surrounding air.

There are two handles on the pot. The outer handle will lift the entire outfit in case it is desired to keep the glue surrounded by the hot water, while the inner handle is for carrying the glue receptacle alone.

**CARE IN FITTING SPARK PLUGS.**—When screwing the spark plug into the cylinder care must be used so that the porcelain insulation on the outside is not cracked. An elusive misfire may frequently be traced to this cause. The current leaks from the grounding in the cylinder and creates an intermittent short circuit. There are several devices which have lately been placed upon the market for detecting just such a state of affairs.





Fig. 1—Filing manifold flange to receive a new gasket properly, after the old one has been scraped off

**T**O the automobilist who takes care of his own car the words "tuning up" express the very essence of careful inspection of the machine and the elimination of the slightest imperfection in any part of the running gear. It is a process which is something beyond the ordinary inspection which the car is given before being taken out for a run in the country, and expresses a greater refinement of every part of the mechanism than that given in the average overhauling. The elimination of noise goes hand-in-hand with the promotion of efficiency, and it may be said, in fact, that the elimination of all noise would mean the attainment of the highest degree of efficiency possible. Friction produces noise and heat which are both forms of energy and hence represent the dissipation of the power which might have been through better mechanical arrangement, added to the propelling force of the vehicle.

It is, of course, understood that it is impossible to prevent the loss of mechanical energy which takes place through the friction of joints and bearings any more than it is possible to eliminate giving away part of the power of the motor by throwing heat into the cooling water to keep the cylinder walls at a temperature at which they will work to the greatest advantage. All these heat losses and other losses are to a large extent necessary, but in the car which has been properly tuned up they have been reduced to a minimum. In the matter of bearings, for instance, an adjustment may be made which, while allowing a small amount of play, still holds the bearing properly to its work. Such an adjustment may be made in the universal joint, as shown in Fig. 2, where the act of making the adjustment is depicted. In this case the block B can be allowed a little play and the efficiency of the joint still be maintained with a slight gain in flexibility. The play given must be very slight—in fact, so slight that it can hardly be detected, but if the adjustment be correctly made, it will be found that the resistance to the free movement of the block in the fork will be practically nothing. Breakage of the universal joint, while not a common occurrence, will sometimes happen where the shaft has been considerably thrown out of alignment on account of some accidental derangement of the drive. Such a case is illustrated in Fig. 3, where B is the casing ring, F the collar, C the clip which has been bent

## Careful Inspection

### Look for and Remedy Leaky

back, and R the spindle about which the missing roller revolves.

Leaky manifolds are encountered at times and the hiss of the loose exhaust is unmistakable. In this case the joint is generally found to be defective owing to the gasket having been burnt or worn out. A very satisfactory repair may be quickly made by merely cutting a new gasket and fitting it in place of the old one. This is not the kind of repair, however, that is made in carefully tuning up the motor to secure the highest efficiency in all its parts, as very often at least a part of the old gasket will find its way into the manifold and cause trouble eventually. If the exhaust pipe is carefully removed and clamped in a vise, as shown in Fig. 1, and the file worked over the surface of the flange after the old packing has been carefully scraped away, a much more satisfactory job will be made and the man who performs the work will have classed himself with those whose automobiles far outlive the cars which receive nothing more than the average care. In filing the flange in the horizontal manner depicted in the illustration referred to above, a burr will be raised on the inner edge of the flange which should be removed. This is done by filing vertically, as shown in Fig. 4, where the operation of removing this burr is depicted.

Besides the matter of manifolds and bearings there are many others which should claim the attention of the automobilist if he entertains the idea of maintaining his car at the highest state of efficiency, either as a matter of economy or pride, or both. One of these points which require the attention of the motorist who aims at the attainment of the highest power possible from his engine and yet is very frequently overlooked is the muffler. A muffler is designed for the purpose of silencing the exhaust, which without it would be very noisy. To silence



Fig. 2—Manner of adjusting for play in universal joint with a wrench and screw-driver

the exhaust a certain amount of power must be sacrificed by increasing the back-pressure against the exhaust of the motor. After a time, especially if the motor has been running with a superabundance of lubricating oil, the muffler becomes clogged with soot and dirt, thereby increasing the back-pressure against the exhaust. The loss of power occasioned by the resistance to the free exhaust is very large, and hence care should be taken to remove the muffler casing from time to time to remove the deposit.

A slipping clutch is an evil that should be corrected as soon

# Will Pay the Owner

## Joints, Slipping Clutches, Etc.

as it manifests itself, for each time that the clutch slips an additional glaze is given the leather if it is a leather-faced cone clutch, and the trouble which at first seemed very unimportant may result in disaster on a steep, slippery hill. The life of the clutch can be prolonged if care is used in driving the car and an occasional dressing with neat's foot oil is applied.

The needle valve on the carbureter will occasionally need grinding in the same manner as the valves in the cylinder head. If it is noticed that too much gasoline is fed to the motor at low speeds the trouble is often at this point. It is, of course, frequently due to the presence of a piece of foreign matter which has found its way from the gasoline tank into the carbureter, but occasionally it will be found that after having driven the car for a long time with the same carbureter the needle valve will require this adjustment. When the valve is ground the attachment of the float will have to be inspected and perhaps regulated in order that the gasoline level in the float chamber will be correct; that is, about 1-32 of an inch below the spray nozzle.

Another feature which may be given attention in the final tuning up of the car is the distance between the points of each spark plug and whether they are choked with soot or are bright and clean. A considerable falling off in power will be the result of a dirty spark plug, and the same may be said to be true of one in which the gap is not great enough. When the gap is too wide the explosions will be irregular or the particular cylinder in which the defective plug is located will be "dead" entirely.

The constant vibration and jar of the car will loosen the battery and other terminal connections after the car has been

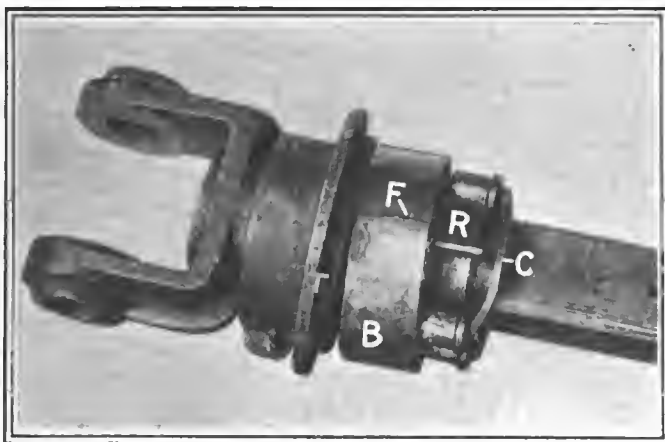

Fig. 3.—A universal joint which has been broken by being knocked too far out of alignment

operated over rough and difficult roads. These should be examined from time to time in order to ascertain if they are tight as well as to determine whether any deterioration has resulted from contact with acids or other materials which would be apt to affect the wiring. If the contact points of all the wiring are first scraped and then rubbed with a piece of emery paper before the binding posts are screwed into position the contact will be much better than if the connection were carelessly made, and the spark will be hotter and hence more satisfactory. Badly-made connections form a resistance against the flow through the elec-



Fig. 4.—Removing the burr after having filed the manifold flange to take the new gasket

tric circuit and hence cut down some of the electro-motive force that might have been used in producing a good spark. A very good plan that is sometimes used in careful wiring is to slip a piece of rubber tube over the wire and the terminal. This will tend not only to protect the wiring from galvanic action, but also to hold it in position in spite of vibration.

The maintenance of a clean radiator and circulating system is of prime importance. When the radiator is designed for a certain motor the area of cooling surface and the quantity of cooling water required for various engine speeds are determined. A factor of safety over the required area is allowed so that in case of an overload or other unforeseen condition the radiator will be able to adequately care for the motor. These calculations are all based on a clean radiator and not on one which has been fouled and clogged through neglect. A monthly cleansing will go far in creating a condition of high efficiency and economy in the motor.

Tire troubles are the bugaboo of the automobilist. The high price of rubber and the necessity of using the purest and highest grades in the manufacture of tires, have brought about this condition. If it were realized that the proper way to take care of a tire is not to place it on the car and then forget it until the much-dreaded blow-out occurs, methodical and frequent inspection of the outer casing would be the rule of every automobilist who desires to have the maximum pleasure from his car at the smallest monetary output. There are many very satisfactory vulcanizing outfits on the market which make it easy for the work to be carried out in a garage which is not overstocked with tools. A car cannot be said to be properly put in condition if it is allowed to go out with the tire casings cut. One of the greatest causes for the rapid deterioration of tires is the fact that water will work through the cuts and rot the fabric. This will eventually lead to a burst which could easily have been prevented with a little energy and foresight. In the points mentioned, as well as in all the other details which will present themselves at different times to the car owner and driver, a careful supervision will be rewarded by a prolongation of the life of the car and increased comfort in driving.



Vol. XXV

Thursday, September 21, 1911

No. 12

## THE CLASS JOURNAL COMPANY

H. M. SWETLAND, President

CONDE NAST, Vice-President and General Manager

E. M. COREY, Secretary and Treasurer

231-241 West 39th Street, New York City

Cable Address - - - - - Autoland, New York  
 Long Distance Telephone - - - - - 2046 Bryant, New York

### SUBSCRIPTION RATES

United States and Mexico - - - - - One Year, \$3.00  
 Other Countries in Postal Union, including Canada - - - - - One Year, 5.00  
 To Subscribers—Do not send money by ordinary mail. Remit by Draft,  
 Post-Office or Express Money Order, or Register your letter.

Entered at New York, N. Y., as second-class matter.  
 The Automobile is a consolidation of The Automobile (monthly) and the Motor  
 Review (weekly), May, 1902, Dealer and Repairman (monthly), October, 1903,  
 and the Automobile Magazine (monthly), July, 1907.

## Track Racing Danger

THE accident that happened last Saturday at the track meet at Syracuse when eleven lives were taken is one that might happen at any track meet where the spectators are not kept in proper bounds. The outer and inner fences, which may be entirely safe for horse racing, are most inadequate when automobiles engage in speed contests, and wherever spectators are allowed to stand close behind such fences, whether on the stretches or on the curves, they place themselves in great danger, for should a tire go at such points there is a chance that the car may dash through the fence. The safety precautions that are adequate for horse racing are not to be even considered as possessing a shadow of what is required for automobiles. The only safety precaution that is adequate for racing cars is a low cement wall such as is used on the Indianapolis speedway; or low plank fences just high enough to catch the hubs of the racing cars and prevent them from leaving the track. Such fences are used on the motordrome in California, and similar precautions were taken on the Atlanta speedway and at the recent Elgin races in front of the repair pits extending along the grand stand.

Track race promoters and owners of horse tracks have been complaining all summer that the American Automobile Association has been placing undue, or unnecessary, restrictions on track races; as a matter of fact they have not been placing half enough restrictions upon them. A track owner imagines that because his track, with fences, paddock and spectator arrangements, is safe for horse racing, it is similarly so for automobile racing. This is as far from the real situation as can be imagined. Spectators must be protected no matter what the cost, and if the automobile sport-governing body does not make its promoters, to whom sanctions have been issued, furnish that protection, then the courts will step in and demand the protection or legislate against track events. What is needed most of all in track races is a safety wall along the outside and the inside of the track where spectators are bound to gather. If this costs too much money then the ground surrounding the

track should be so fenced off that spectators cannot get within 75 feet of the side of the track—that is, the inner or the outer fence. This neutral zone would give the driver a chance to reduce the car speed and give spectators a chance for safety. Such fencing would not be a hardship because with all of the spectators that distance back from the track a better general view of the contest would be afforded. Quick action of this nature should be taken by the American Automobile Association, and the Manufacturers' Contest Association should be ready to back up the A. A. A. in such work. Human life must be protected; the spectator has to be looked after; the driver knows he is engaged in a dangerous occupation and takes his chances, but this does not apply to the spectator.

\* \* \*

## Practical Road Work

GETTING the different road commissioners of various States together for joint conferences and making an inspection of the roads in their respective States, as was done this week with the co-operation of the Touring Club of America, is a commendable enterprise. Good roads conventions are generally held in hotel parlors, or in the auditorium of a theater or music hall; but here is an example of where the meeting has been taken onto the highway, where the roads are on exhibition. It is the most practical, common-sense scheme that has been worked out along the good roads line and should be most productive of results. It is one thing to talk the construction and maintenance of good roads in a nice warm room at a convention, and it is another thing to get into a line of automobiles and go over the roads in rain and shine and see at close quarters just what are the conditions.

If there is any department of the automobile industry that needs the practical seed sown—and good roads must be considered such a department—it is this one. Many good roads conferences are based on road construction ideas of ten years ago under the horse régime. This is wrong. What the road commissioner has to do is to build a road for the automobile and study from present conditions what are the defects in existing highways. When the automobile road is finished the commissioner must see how it stands the traffic. He can best study this by travelling over the road in the automobile.

Other States would do well to imitate the example that some of the New England States have set. It is better for the commissioners of several States to get together and compare notes. The road chiefs of one State may imagine they have the entire world at their feet in the matter of road building, but when they meet with commissioners from other States they may find that there are other chapters to the good roads ritual. Unanimity is most essential in good roads work. The automobile is an interstate vehicle of travel; each automobile owner has more or less interest in the acts of the road builders in adjoining States. For this reason the interstate scheme of inspection is preferable to the State system. Continue the State system; where it has not been instituted, start it at once. But by no means end here; take the additional step of getting several States to unite. This will be of great assistance when it comes to the matter of mapping out and building as well as caring for interstate road systems.

## Gossip of the Coming Shows

**A**RRANGEMENTS for both National automobile shows that will be held in New York in January, are progressing satisfactorily. While no definite official announcement has been made that the third show has been called off, nevertheless it will not be held. The reasons for this are twofold. In the first place the Columbus Buggy Company, Geneva Wagon Company, Seitz Automobile and Transfer Company, Maytag-Mason Motor Company, Lion Motor Sales Company, Alpena Motor Car Company, Roder Car Company, Vandewater and Company, Crawford Automobile Company, Warren Motor Car Company, James Cunningham and Son, McFarlan Motor Car Company and the Michigan Buggy Company, all of which were represented at the show held under the auspices of the A. M. C. M. A. E. last year at the Palace, have been reinstated to good standing in the N. A. A. M. and will show at the exhibition of that organization at the Grand Central Palace from January 8 to 19.

The N. A. A. M. show is looming larger every day and in the accessory line it will probably be of such size as to compare favorably with the display in Madison Square Garden. The news was announced to-day that no dates had been given for the third show which was to have been held at the Palace. The management of the Palace would say nothing further and Mr.

Longendyke, secretary of the A. M. A. A., was not available for a statement.

Aside from the twenty odd concerns members of the N. A. A. M. and not members of the Automobile Board of Trade, all of which will show at the Palace, the list given above will constitute an imposing array of exhibitors at the N. A. A. M. show.

At the offices of the Motor and Accessory Manufacturers it was announced that circulars had been issued to its members asking that applications be made for space at either of the national shows. Drawings will be held October 4. In some cases the same concerns will exhibit at both shows and it is estimated that the total number of members of the organization will approximate 150 at each. Independent manufacturers will have an opportunity to display their wares at all the automobile exhibitions this year.

With regard to the Garden exhibition, which will be of two weeks' duration, the car exhibitors will include only members of the organization. But there will be numerous companies outside its membership which will show other lines than automobiles. The motorcycle section, which will be housed on the Twenty-seventh street side of the Garden, will be far more complete than ever before.

### New Motor Speedway

**E**ARLY last week was incorporated in Trenton, N. J., the Metropolitan Motor Speedway Association, whose object, as stated in the incorporation papers, will be to conduct races, contests, exhibitions with automobiles, balloons, airships, etc. The incorporators named in the articles are I. Newton Quimby, Francis V. Dobbins and Edmund S. Johnson. The capital named is \$1,500,000.

The location selected for the speedway, which will be a two-mile circuit, is on the meadows between Newark and Jersey City. The ground is at present a swamp, but the amount named in the articles of incorporation would seem to be quite sufficient to float the venture, for the ground is absolutely useless as it stands at present, and will be for years to come for any other purpose than that contemplated in the new incorporation. It is located about five miles west of the Hoboken Ferry, and could be reached from Columbus Circle in less than a half hour.

The course as planned will have but two real turns. On the south side, there will be a straightaway of 3,421 feet with two smaller straightaways on the backstretch—one 1,280 feet and the other 1,745 feet long. The track will be of sufficient width to accommodate large fields of starters, and so banked at the turns as to combine speed with safety.

The total amount of land involved is 330 acres, giving ample room for stands to accommodate 100,000 people and parking space for 10,000 automobiles. As regards accessibility, the new speedway is on the lines of the Pennsylvania; Delaware, Lackawanna & Western and Erie railways, including the new line from Manhattan Transfer into the Pennsylvania station at 33d street and 7th avenue. The Newark and Jersey City turnpike is on the south side of the proposed speedway, and the Belleville turnpike touches its northeastern corner, the trolley line of the Public Service Railway Company following the former from Jersey City to Newark.

### Glidden Has 50 Entries

**A**BOUT two weeks from the date set for closing entries for the 1911 Glidden tour, the list contains 50 names and from present indications will be increased to at least 75 before the time limit has elapsed. The additional names that have been placed on the list during the past week include the following: E. R. Brackett, Jacksonville, Fla., Stoddard-Dayton; Atlanta Ad Men's Club, Atlanta, Ga., Corbin; R. S. Hall, Ocala, Fla., Cadillac; J. Epps Brown, Atlanta, Thomas; Charles Crook, Atlanta, Ga., Packard; Bob King, Anderson, S. C., Mitchell; K. P. McNeil, Jacksonville, Fla., Cadillac; L. C. Brown, Atlanta, Ga., Mitchell; St. Elmo Massengale, Atlanta, Ga., Garford, and Griffith Implement Company, Athens, Ga., Schacht.

The pathfinding Flanders has finished its course and is in Jacksonville, after a pleasant and speedy trip. The worst roads of the tour were found the last day and at present a big gang of men is engaged in making improvements.

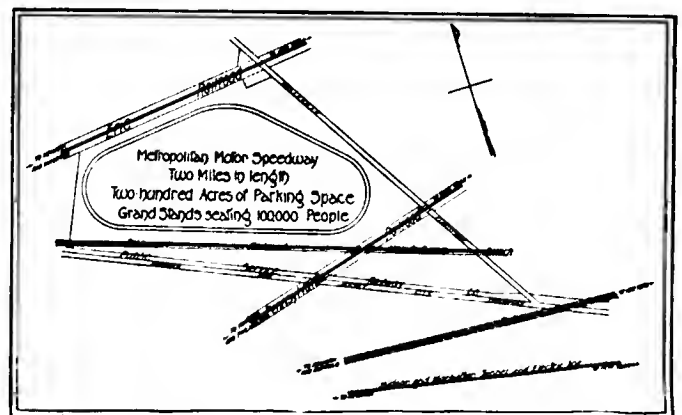

Plan of the proposed Metropolitan motor speedway on the meadows between Jersey City and Newark



Bird's-eye view of the new and modern plant of the American Simms' Magneto Company at Bloomfield, N. J.

**B**LOOMFIELD, N. J.—The main building of the new plant of the American Simms Magneto Company, occupying 4 1-2 acres. A unit type of construction has been employed, consisting of reinforced concrete beams and girders. The walls contain 18,942 square feet of glass with a wall surface of 16,500 square feet. There are 15,500 panes of glass, 3,100 feet of partition, about 1,400 electric lights, 1,000 steel lockers and 650 shaft hangers used for the support of shafting.

The power house is a separate building in close proximity to the main plant, and contains 6,000 square feet. There is an artesian well which goes down 560 feet on the premises, and supplies 65 gallons of water per minute for the boiler feed and drinking water. Between the power house and main plant is located a reservoir of 90,000 gallons capacity to collect the rain water for the purpose of neutralizing the artesian well water.

LOUISVILLE, KY.—The Dunham Auto Company has taken the agency for the Fiat car.

HARTFORD, CONN.—Kilby & Barrett have taken the local agency of the Bassel truck for this section.

GRAND RAPIDS, MICH.—The Ignition Starter Company has decided to remove its factory to Detroit.

LOUISVILLE, KY.—The Glenn - Bauer Motor Company has acquired the agency for the Broc electric.

LOUISVILLE, KY.—Oscar Erni, of New Albany, Ind., is the new agent for Inter-State cars in Louisville.

LOUISVILLE, KY.—The Wieland Company, 217 South Ninth street, has closed a contract to handle the Elmore car.

MINNEAPOLIS, MINN.—The Foster-Lawrence Company has been formed in St. Paul and will handle the Stearns car at 142 West Fifth street.

BOSTON, MASS.—The agency for the National car in Boston has been dropped by Frederick Randall, who has been handling it for some months.

TRACY, CAL.—C. A. Howard has taken the agency for Marion cars in San Joaquin County and will maintain salesrooms in Tracy and Stockton.

KANSAS CITY, Mo.—On Wednesday last the entire stock of the McFarlan Six Sales Company was destroyed by fire. The loss is estimated at \$5,000.

MANITOWOC, WIS.—Hagen & Van Akin have been appointed local agents for the Rambler and intend to build a garage and salesroom in the Spring.

COSHOCOTON, OHIO—The City Council of Coshocton, Ohio, has enacted an ordinance prohibiting the use of any excepting rubber-bulb auto horns within the city limits and making it a misdemeanor for an autoist to leave his muffler open on the city streets.



The new Gray & Davis factory building, Boston, which is devoted exclusively to the manufacture of dynamos for use in automobile lighting. The factory is constructed entirely of cement brick



WASHINGTON, D. C.—The DeTamble agency has been given to the Ohio Motor Sales Company, who also handles the Ohio at 302 Sixth street, N. W.

BOSTON, MASS.—The Henry Motor Car Company that handles the Henry for New England is being reorganized so that it will have a larger working capital.

MILWAUKEE, WIS.—The Simplicity Steam Vulcanizer Company has opened a Milwaukee office at 403 Grand avenue under the management of A. S. Pierce.

SACRAMENTO, CAL.—J. L. Whitmore, proprietor of the Central Auto Company, of Stockton, Cal., has taken on the Chalmers agency for Sacramento and vicinity.

MILWAUKEE, WIS.—The Putnam Automobile Company has taken occupancy of the garage formerly owned by the Mau Automobile Company at 312 Twelfth street.

MILWAUKEE, WIS.—John S. Collins, of Saginaw, Mich., has been appointed manager of the Wisconsin branch of the Buick Motor Company to succeed George P. Hewitt.

BOSTON, MASS.—The F. R. Parker Company that handled the Elmore in Boston for several years has gone out of business and the Elmore is temporarily without an agency in the Hub.

LOUISVILLE, KY.—Edwin H. Chase, Jr., is the new manager of the local branch of the Olds Motor Works. He succeeds T. F. Smith, who returns to the factory at Lansing, Mich.

PHILADELPHIA, PA.—Announcement has been made of the removal of the Central Auto Supply Company to larger and better equipped quarters at the southwest corner of Broad street, Ridge and Fairmount avenues. The company deals in automobile tires, accessories and supplies, and motor-ing apparel for men and women. Frank Stehle is manager.

MILWAUKEE, WIS.—The George W. Browne Motor Company, factory distributor of Overland and Marmon cars, is now located in its new garage and salesrooms at 458-460 Milwaukee street.

STEVENS POINT, WIS.—G. A. Gullickson, of Iola, Wis., and P. W. Holton, of Nelsonville, Wis., have formed a partnership and will handle Ford business in this territory, with headquarters in the McDonald building.

COLUMBUS, OHIO.—The Rusk & Hallock Automobile Company, located at 244 North Fourth street, Columbus, Ohio, has closed a contract to handle the DeTamble in thirty counties in central and southeastern Ohio.

MILWAUKEE, WIS.—The Goodyear Tire & Rubber Company, of Akron, Ohio, has opened a Milwaukee branch at 134-136 Oneida street, in charge of H. B. Ziegler, formerly traveling representative in this State.

BOSTON, MASS.—The latest concern to establish itself in the Hub is the Boston Motor Wagon Company. Salesrooms have been opened in the Motor Mart, Park square. G. Frank Davenport is manager of the new company.

SAN FRANCISCO, CAL.—The Oakland cars will hereafter be represented here by the Consolidated Motor Car Company, with G. A. Boyer as manager. This concern is also northern California representative of the Pope-Hartford.

MINNEAPOLIS, MINN.—Motorists in St. Paul want the fire department to standardize its warning signals on apparatus and then they will be willing to keep that style of sirens off their cars. They protested against a proposed ordinance prohibiting the use of sirens and other horns on all motor vehicles except those belonging to the fire department, hospital ambulances, police and fire insurance patrols.

SAN FRANCISCO, CAL.—The northern California agency for the Oakland car has been taken by the Consolidated Motor Car Company. The latter for the past two years has been distributor of the Pope-Hartford car exclusively.

MILWAUKEE, WIS.—The Oakland Motor Car Company, of Pontiac, Mich., has established a Wisconsin branch at 116 Mason street, Milwaukee, in charge of R. A. Creek. The local agent is the Smith-Hoppe Auto Company, 116 Mason street.

COLUMBUS, OHIO.—Frank J. Girard, who was connected with the Curtin-Williams Automobile Company, of Columbus, Ohio, for eleven years, has taken the central Ohio agency for the Peerless. The agency is located at 174 North Fourth street.

SEATTLE, WASH.—F. A. Bardshar, manager of the Stevens-Duryea and Marion agency, has recently added the Maxwell car to his line. His territory will include the State of Washington west and north of the Columbia river.

KANSAS CITY, MO.—The Bond Motor Company, distributor for the Franklin, Everitt 30 and Krit cars, will erect a three-story building at 1615-1617 Grand avenue, in the heart of automobile row. The building will cost \$60,000.

PHILADELPHIA, PA.—New and larger quarters have been established by the Century Automobile Sales & Supply Company at 520 North Broad street. The company will be the agent in Philadelphia and vicinity for the Pathfinder automobile.

SEATTLE, WASH.—George E. Johnson, manager of the Mitchell Motor Car Company, Seattle branch, was elected president of the Seattle Auto Dealers' Trade Association at the annual election held the past week. P. R. Sands, of the Flanders agency, was elected vice-president; Ira D. Lundy, of the Stoddard-Dayton agency, treasurer, and E. J. Strelau, secretary.

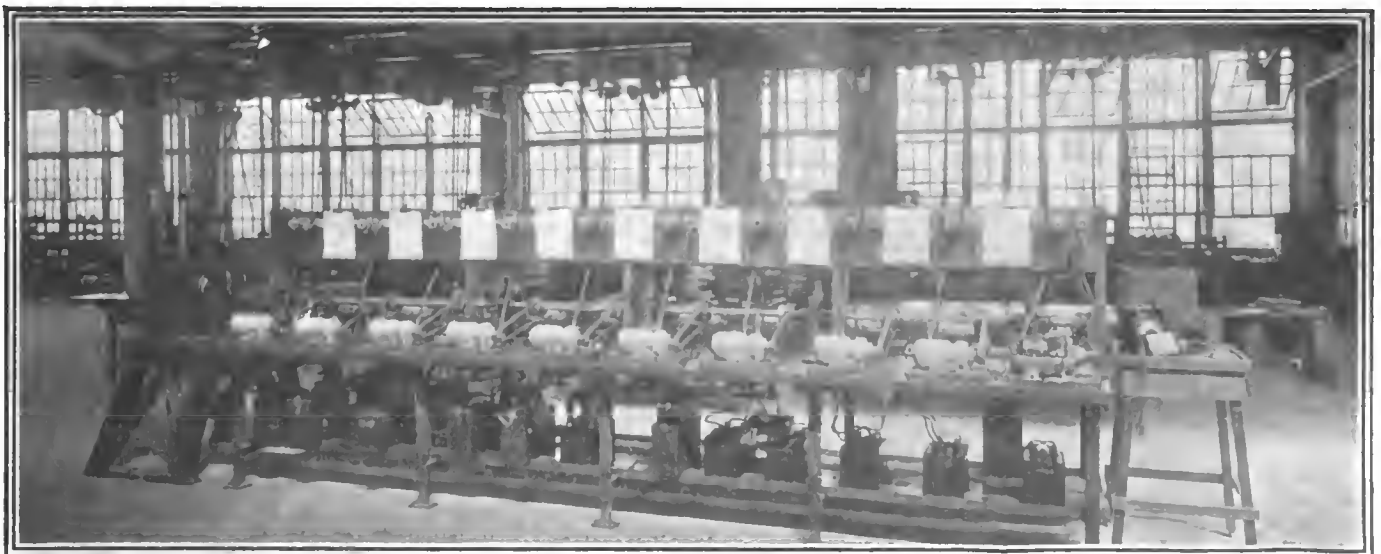

Test bench where dynamos for car lighting are tried out and checked to insure uniformity of service. Careful records are kept of the performance of each instrument during the trials

MILWAUKEE, WIS.—Walter S. Shawvan, who has been associated with the McDuffie Automobile Company, Wisconsin agent for the Stoddard-Dayton for several years, has been appointed Milwaukee agent for the Thomas Flyer.

SAN FRANCISCO, CAL.—B. F. Jacobs, sales manager of the Motor Car Manufacturing Company, of Indianapolis, has placed the northern California agency for the Pathfinder and Parry cars with the Motor Car Manufacturing Sales Company, of San Francisco.

KANSAS CITY, Mo.—A change of managers has been made in the local United Motors branch. George W. Jones, former manager, has taken charge of the Des Moines branch and C. E. Hathaway, brother of the district manager, is now in charge of the local branch.

MILWAUKEE, WIS.—The Hichman-Lauson-Diener Company, 222-224 Fourth street, Milwaukee, Wisconsin distributor of the Ford, has leased the big garage and salesrooms of the McDuffie Automobile Company, Wisconsin agent for the Stoddard-Dayton, at 141-145 Eighth street.

LOS ANGELES, CAL.—There will be no auto show this year under the auspices of the Los Angeles Motor Car Dealers' Association. Final action on the proposition was taken at a meeting of the officials during the past week. The show was voted down by 19 against and only 8 for a show.

SAN FRANCISCO, CAL.—The local branch house of the Lozier Motor Company, of Detroit, is now permanently located in its magnificent new quarters on Van Ness avenue, close to the corner of Golden Gate, which is regarded as the center of automobile trade activities in San Francisco.

COLUMBUS, OHIO—The E-M-F & Flanders Sales Company is the name of a new concern organized to handle the E-M-F, Flanders and Flanders Electric in Columbus, Ohio. George R. Thomas is general manager. The salesroom and repair department is located at 264 North Fourth street.

LOUISVILLE, KY.—Exhibitors at the Kentucky State Fair this week included the following: Wilder Motor Car Company, Everitt car; Banks Motor Car Company, Ford car; Studebaker Corporation, E-M-F and Flanders cars; Louisville Auto Supply Company, accessories; Racine Auto Tire Company, Racine tires.

MINNEAPOLIS, MINN.—A deal for a three-story garage and sales building at 1629 Hennepin avenue was closed last week by L. W. Place, assistant general manager of the Olds Motor Works, of Lansing, Mich., with L. H. Fawkes. The structure, including property on which it is to stand, will cost nearly \$100,000.

COLUMBUS, OHIO—The Broad-Oak Automobile Company, 622 Oak street, Columbus, Ohio, has taken the central Ohio agency for the Chalmers and Pierce-Arrow for the season of 1912. The territory covered for the Chalmers consists of eight counties surrounding Columbus and the territory covered by the Pierce-Arrow is ten counties.

APPLETON, WIS.—Kenneth W. Brewer, formerly principal of Appleton High School and more recently traveling representative of the Baker Motor Vehicle Company, has organized the Brewer-Baker Company to distribute the Baker electric in Indiana and Kentucky. Headquarters have been established at 426-428 North Capitol avenue, Indianapolis.

GRAND RAPIDS, MICH.—The former Grand Rapids Overland agency and the Economy Garage have been merged and will henceforth be known as the Overland Motor Company, with salesrooms in the newly built garage on Island street. Repair rooms and day and night garage service will be maintained in the old fire engine house on Lagrave street between Island and Oak streets.

WASHINGTON, D. C.—Plans are under way to organize a sociability run from Washington, D. C., to Winchester, Va., on October 16, at which time the Glidden tourists will pass through that historic town. Winchester is the nearest point to Washington the Glidden tourists will touch and the run is being planned to give the national capital motorists a chance to see the big Glidden caravan.

WILMINGTON, DEL.—The T. C. Bradford Company, at Tenth and Tatnall streets, and the Wilmington Automobile Company, nearly opposite on Tenth street, have announced that they will handle new lines, the former having taken the agency for the Premier, and the latter for the Chalmers car and Alco truck. The Gomery-Schwartz Motor Company has established a Hudson-Garford agency at Fifth and Orange streets.

GRAND RAPIDS, MICH.—The automobile exhibit at the West Michigan State Fair was the largest in the history of that exposition. There were seven exhibitors as follows: Grand Rapids Auto Company, E-M-F and Flanders 1912; Moran Auto Sales Company, Maxwell; Overland Motor Company, Overland; John Vlasblom, 1912 Mitchell; S. A. Dwight, Everett; W. S. Farrant, Chalmers and Studebaker electrics; Becker Auto Company, Ford.

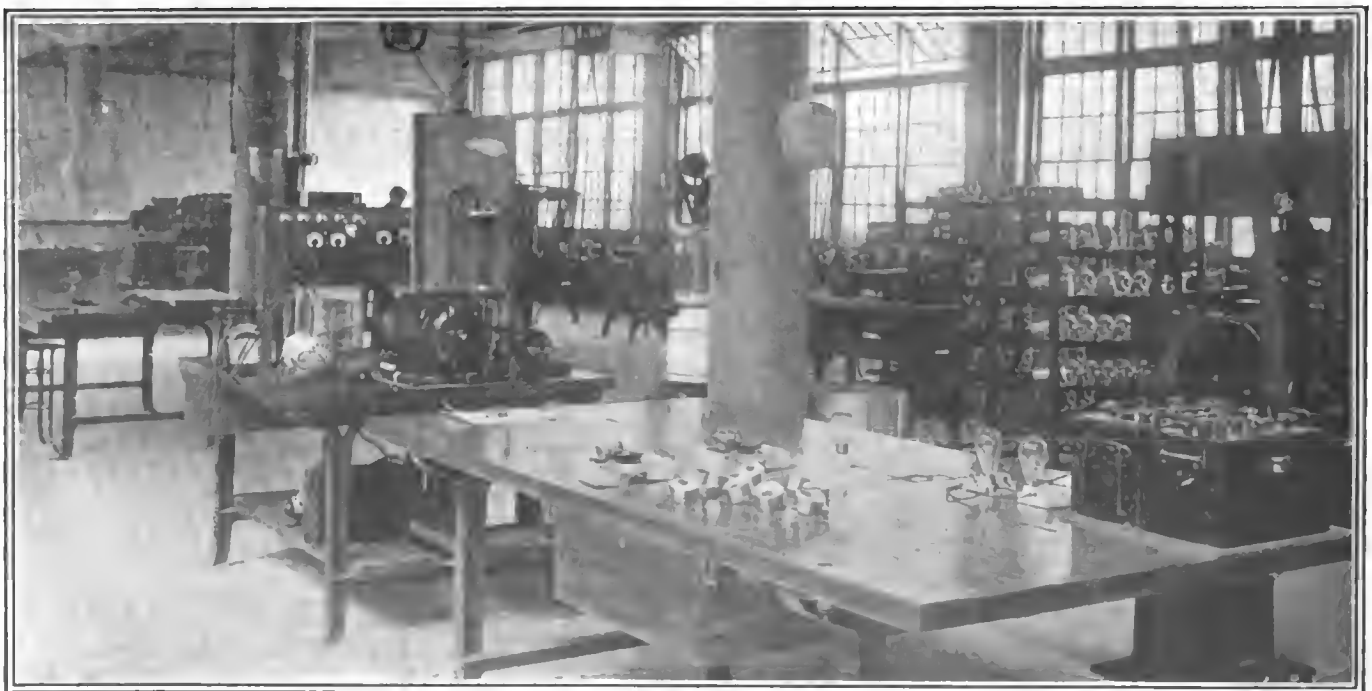

Where the inspections and tests are performed upon meters, instruments, cutouts, etc., at the Gray & Davis factory. The first bench is for general inspection and the second is used for the running tests

MILWAUKEE, WIS.—Jay E. Morehouse, State distributor of the Cole, has been appointed Wisconsin distributor for the Hupmobile, succeeding the Hearne Motor Company, Chicago and Milwaukee. Mr. Morehouse has leased the large garage at 82-84 Farwell avenue. The headquarters of the Wisconsin branch of the Winton Motor Carriage Company, which have been located with the Hearne branch at Eighth and Wells streets, have also been transferred to 82-84 Farwell avenue.

COLUMBUS, OHIO.—The Hudson Motor Car Company, of Columbus, Ohio, 243 North Fourth street, agent for the Hudson and American in thirteen counties in central Ohio, has made the following contracts for subagencies for the coming year: W. L. Gage Automobile Company, Logan, Ohio; Madison County Automobile Company, London, Ohio; Charles W. Stevens, Newark; The Mader Auto Company, Circleville, and the Gaither Automobile Company, Springfield, Ohio.

SAN FRANCISCO, CAL.—A complete rearrangement of the agencies handling the tires of the United States Tire Company in northern California has just been effected. The distribution of the Morgan & Wright and Hartford lines has been taken over by a direct branch of the United States Tire Company, with headquarters at 414 Van Ness avenue. The G & J line is placed with Weinstock-Nichols Company, who until now have handled the Morgan & Wright line, and whose vice-president, A. D. Nichols, was the inventor of the Nobby tread. The Continental line goes to the Gorham-Revere Rubber Company. Chanslor & Lyon, former distributors of the Hartford tires, have taken the Pacific Coast agency for the Kelly-Racine tire.

NEW YORK CITY.—The American Express Company has just placed its fifth repeat order with the American Locomotive Company for Alco trucks. This order calls for three more 3 1-2-ton trucks. With these three trucks the American Express

Company has thirty-one Alcos in its service. Twenty-five of these are used in New York City and three in Chicago. The trucks just ordered will be placed in the New York service, and will be used for transfer work.



## Automobile Incorporations

### AUTOMOBILES AND PARTS

BOSTON, MASS.—Paddon Motor Co.; capital, \$3,000; to deal in automobiles. Incorporators: Samuel N. Paddon, John Wilbur Paddon, Charles R. Codman.

CAMDEN, N. J.—Auto Chemical Fire Engine Co.; capital, \$1,000,000; to manufacture self-propelled fire equipment. Incorporators: F. R. Hansell, I. C. Clow, John A. McPeak.

CHARLESTON, S. C.—King Automobile & Repair Co.; capital, \$5,000; to deal in motor cars and repair them. Incorporators: S. B. King, Jr., W. A. King.

CHICAGO, ILL.—Packard Motor Car Co., of Chicago; capital, \$50,000; to manufacture and deal in automobiles. Incorporators: Leslie J. Ayer, William Fogel, William L. Barnum, Jr.

CLEVELAND, OHIO.—Joseph Cormier Co.; capital, \$2,000; to deal in automobiles, parts and accessories and to do a general machine and repair business. Incorporators: R. M. Calfe, J. G. Fogg, John F. Wilson, Joseph Cormier, Charles M. Selling.

COLUMBUS, OHIO.—Motorette Co., of Columbus; to sell Motorettes in its territory. Incorporator: H. B. McElroy.

DALLAS, TEX.—Munger Automobile Co.; capital, \$2,500; to sell automobiles. Incorporators: S. I. Munger, Sr.; S. I. Munger, Jr.; L. R. Munger.

DAYTON, OHIO.—Heatherman-Solliday Motor Co.; capital, \$20,000; to manufacture and deal in automobiles, parts and accessories. Incorporators: Frank B. Heatherman, Charles H. Solliday, Grace B. Heatherman, Zora Solliday, Joseph D. Chamberlain.

LIMA, OHIO.—Blevins Motor Sales Co.; capital, \$5,000; to deal in automobiles. Incorporators: H. W. Blevins and others.

NEWARK, N. J.—Commercial Car Sales Co.; capital, \$5,000; to sell automobiles. Incorporators: Joseph J. Rafter, John T. Walsh, John W. Phillips.

NEWARK, N. J.—Commercial Motor Truck Construction Co.; capital, \$125,000; to make trucks. Incorporators: Wm. Dimond, J. True, W. Turton.

NEW YORK CITY.—Beasley Company; capital, \$150,000; to manufacture, sell and store automobiles, machinery, etc. Incorporators: Robert F. Pratt, Albert E. Beasley, Thomas Moynam.

NEW YORK CITY.—International Auto Sales Co.; capital, \$25,000; to sell automobiles. Incorporators: Henry J. Levy, David Schwartz, Aaron Klein.

Morgan Sales Co.; capital, \$15,000; to deal in automobiles and accessories. Incorporators: Pierre A. Proal, Chas. A. Duerr, Edgar B. Lynch.

RIDGEFIELD PARK, N. J.—Ridgefield Engineering Works; capital, \$125,000; to manufacture engines, machinery, etc. Incorporators: Robert Burns, Jr., Samuel J. Katzberg, Daniel W. Steele, Jr.

ROCHESTER, N. Y.—Overland Rochester Co.; capital, \$30,000; to manufacture engines, etc. Incorporators: Edward D. Creed, Royal R. Scott, Clifford F. Cribb.

YOUNGSTOWN, OHIO.—Cutting Motor Sales Co.; capital, \$5,000; to deal in automobiles. Incorporator: J. B. Ditchon.

### AUTOMOBILE GARAGES, ACCESSORIES, ETC.

BUENOS, OHIO.—Punctureless Tire Co. of Ohio; to deal in Dabl punctureless tires.

CAMDEN, N. J.—Stone Harbor Garage & Marine Railway Co.; capital, \$55,000; to operate garages and marine railways. Incorporators: Charles L. Large, Louis H. Matthez, John D. Yarrow.

CHICAGO, ILL.—Sberidan Park Garage Co.; capital, \$5,000; to deal in motor vehicles and conduct a general garage business. Incorporators: Harold H. Hart, James P. Doane, Marie Phillips.

JESSEY CITY, N. J.—Mechanical Rubber Tire Co.; capital, \$100,000; to manufacture tires and other rubber goods. Incorporators, William T. Wheeler, Frank B. Crawford, Frederick Carter.

JESSEY CITY, N. J.—Metropolitan Motor Speedway Association; capital, \$1,500,000; to conduct races, exhibitions and contests with automobiles, airships, etc. Incorporators: I. Newton Quimby, Francis V. Dobbins, Edmund S. Johnson.

LOUISA, KY.—Hays Oil Co.; capital, \$10,000; to make and refine lubricants, etc. Incorporators: Tom Hays, G. R. Burgess, H. C. Sullivan, D. J. Burchett, J. L. Carey.

NEW YORK CITY.—Endurance Tire & Rubber Co.; capital, \$10,000; to manufacture tires and other rubber goods. Incorporators: W. G. H. Randolph, Edward W. Tabor, James E. Bennett.

NEW YORK CITY.—J. H. Simms Co.; capital, \$10,000; to manufacture and deal in automobile accessories, supplies, etc. Incorporators: J. H. Simms, C. F. Oscar Arthur Meyer.

SIOUX CITY, IA.—E. C. McCormack Co.; capital, \$10,000; to conduct a general garage business. Incorporators: E. C. McCormack, H. W. Hope-well.



Machine toolroom and assembling floor of the factory, showing a general scene in the interior of this important section of the new plant. Light is plentiful and space has been arranged with a view to efficiency

# OF INTEREST *to the* INDUSTRY



New Franklin racing car recently built for Ralph C. Hamlin, of Los Angeles, Cal.

**LOS ANGELES, CAL.**—The Franklin Automobile Company has shipped to Ralph C. Hamlin, its local dealer, a racing car built on a model D chassis which Ralph C. Hamlin is to enter in the Los Angeles-Phoenix Desert Race November 4-6. The car may also be entered in the Los Angeles Motordrome and Santa Monica races. The chassis is stripped, bearing only the seats, gasoline tank and tool box.

**ST. LOUIS, MO.**—The Bond Motor Car Company, which has represented the Franklin Automobile Company in 26 of the 115 counties in Missouri, is to cover the entire State this coming season.

**TOLEDO, OHIO**—A deal was this week consummated by which H. H. Dennis, manager of the Rambler Motor Sales Company, of Toledo, will have the exclusive agency of the well-known Detroit Electrics in that territory.

**CALGARY, ALBERTA**—The Austin - Dick Company, of Calgary, Alberta, has been signed up as a dealer by the Franklin Automobile Company, succeeding the Alberta Franklin Company. The territory is the entire province of Alberta.

**RACINE, WIS.**—The Racine Manufacturing Company, one of the largest builders of motor car bodies in the country, has been obliged to establish a 24-hour-per-day schedule in most departments and by the end of the month will be working its entire plant all hours of the day and night.

**ANDERSON, IND.**—The Remy Electric Company has closed a contract whereby the Russel Motor Car Company, of Melbourne, Australia, will become general agent of Remy devices in that country. The Russel Motor Car Company is a large Toronto firm, with branches in the principal cities in Canada and Australia.

**TOLEDO, OHIO**—The local branch of the Buick company will be closed out on October 1, according to information given out by Manager George P. Dowling, and the northwestern Ohio business will thereafter be handled on an agency plan.

**DETROIT, MICH.**—Claude S. Briggs has resigned as general manager of the Brush Runabout Company to head a new motor car concern in Detroit. The new car will be named the "Detroit" and will be built in two models—five-passenger tourist at \$700 and a two-passenger roadster at \$650.

**DETROIT, MICH.**—W. A. Crowe, of Detroit, Mich., who recently placed on the market a new car known as the "Crowe 30," is negotiating with the Industrial Association of Grand Rapids, Wis., for the establishment of the plant in the Wisconsin city. The car is designed by W. W. McIntyre.

**DETROIT, MICH.**—To market the product of the Marquette Motor Company, a sales company, known as The Marquette Company, has been incorporated as a subsidiary to General Motors Company. The officers are as follows: Thos. Neal, president; O. C. Hutchinson, vice-president and manager; James T. Shaw, treasurer; Standish Backus, secretary; T. S. Merrill, assistant secretary and assistant treasurer. The Marquette Company will handle the Rainier and the Welch-Detroit cars, likewise the new car which will be produced under the name Marquette. Branches of The Marquette Company have already been established in New York, Boston and Chicago. The management of the company is in the hands of Mr. O. C. Hutchinson, who is also vice-president. The headquarters of the company are 1302 Jefferson avenue, Detroit, Mich.

**LIMA, OHIO**—The following officers have been elected by the stockholders of the Gramm Motor Company: President, A. L. White; vice-president and general manager, B. A. Gramm; treasurer, W. T. Agerter; secretary, F. E. Lamb. The stockholders also authorized an increase in the capital stock from \$500,000 to \$1,250,000.

**PHILADELPHIA**—What is undoubtedly the most handsome and complete structure of its kind in Automobile Row has just been completed at No. 319 North Broad street and will henceforth be the Quaker City home of the Packard Motor Car Company, of Philadelphia. The new building is eight stories in height and built of steel and reinforced concrete, affording every facility for promptly and effectively handling the increasing business of the company and for rendering a most complete service to Packard users. The company owns the whole block on which the structure stands, 302 feet deep, upon which, should business development warrant it, the present building could be duplicated. The building is handsomely furnished.

**FINDLAY, OHIO**—The Gramm Motor Car Company, which removed from Bowling Green to Lima early last Spring, held its first annual stockholders' meeting at Lima last Wednesday and elected the following directors: A. L. White, B. A. Gramm, F. E. Lamb, W. T. Agerter and M. Bernstein. The capital stock of the company has been increased to \$1,250,000. Of this amount \$750,000 is common and the balance is 7 per cent. cumulative stock. The directors held a meeting immediately after the stockholders' meeting and elected the following officers: President, A. L. White; vice-president and general manager, B. A. Gramm; treasurer, W. T. Agerter, and secretary, F. E. Lamb.

**NEW YORK CITY**—Thomas Neal, president of General Motors Company, arrived in New York on Saturday on the White Star liner "Cedric," after spending the month in Europe in the interests of the company. While in London arrangements were consummated whereby the Bedford Motors, Ltd., passed completely into the ownership of General Motors Company. Prior to this time General Motors Company owned a part interest in the English concern, but through the new arrangement the Bedford Motors, Ltd., will be operated under the exclusive control of the big Detroit company. It will be used largely for the purpose of placing the Buick car on the foreign market. The Buick chassis will be exported directly from the Flint plant and completed in the London factory of the Bedford company, whence the cars will be distributed all over the transatlantic market.



# PATENTS GONE TO ISSUE

**COMPENSATING MECHANISM**—A balancing gearset for the driving axle of motor vehicles.

4. As Fig. 3 shows, this mechanism for a two-section axle consists in principle of a drive member loosely sleeved over both of the meeting axle ends and provided with an internal divided chamber, a friction rim mounted on each of the ends mentioned within the internal chamber, and means within these rims to make separate locking engagement thereof with the drive member above referred to.

No. 1,000,870—to John Frank Rogers, Cleveland, Ohio. Granted September 12, 1911; filed August 10, 1908.

**TWIST DRILL**—New and singular form of drill.

5. The drill is formed from a flat bar and has a tapered shank which is twisted alternately in opposite direction a number of times.

No. 1,002,846—to Frederick W. Hoefler, assignor to Hoefler Manufacturing Company, Freeport, Ill. Granted September 12, 1911; filed January 20, 1910.

**MEANS FOR ENGINE COOLING**—A system proposed for internal combustion engines.

3. The invention covered by this patent (Fig. 2) refers to the combination of an internal-combustion engine cylinder, with a water reservoir, a blower receiving water in minute quantities from that reservoir so as to form moistened air, and a mantle around the cylinder where the moistened air is led to cool the surface of the cylinder. The reservoir is encased and communicates with the blower space, and means are provided connecting the mantle around the cylinder and the casing.

No. 1,003,290—to Roberto Fritz Emil Okrassa, Antigua, Guatemala. Granted September 12, 1911; filed May 13, 1910.

**CLUTCH**—The combination of two members with a pawl.

1. This clutch is composed of a continuously rotating drive part and a driven member carrying a pawl movable to engage thrust portions of the driving member. The pawl is normally coacting with means for holding it back from engagement with the thrust portions mentioned and having a cam surface; a projection revolves with the driven member and at each revolution cooperates with the cam surface to move the above-mentioned means to normal position, a mechanism being also provided to shift the means retaining the pawl.

No. 1,002,853—to William H. Lanning, Jr., Toledo, Ohio. Granted September 12, 1911; filed June 12, 1911.

**OIL CAN**—A positive-working oiler.

1. The oil can comprises a receptacle and spout, a spout-closing valve seated in the end of the spout, a valve for admitting air to the oil receptacle, means for opening both valves simultaneously, means for keeping both normally closed and locked.

No. 1,002,995—to August Ivar Johnson, Concord, N. H. Granted September 12, 1911; filed December 19, 1910.

**RADIATOR**—Water-cooling apparatus of the cellular type.

3. The radiator has a vertical rear wall provided at its edge with a bead which projects laterally and rearwardly from the wall and which is provided at its rear edge with a rearwardly projecting flange adapted to support an engine hood, a peripheral wall being provided at its rear edge with a bead which projects laterally and rearwardly and which is secured over the head of the rear wall above referred to.

No. 1,002,978—to John M. Fedders, Buffalo, N. Y. Granted September 12, 1911; filed May 27, 1911.

**VARIABLE-SPEED GEARING**—A combination of two shafts carrying stepped gears.

2. This patent relates to the combination in a variable speed mechanism, Fig. 1, of two parallel shafts, one driven and the other driving, oppositely stepped gears on these shafts, slides located intermediate these shafts adjacent the ends of the stepped gears and a bar slidably supported in the gears. On this bar is mounted an intermediate gear adapted to mesh with the opposite stepped gears, means being provided to shift the slides in order to move the bar laterally to bring the intermediate gear into or out of mesh with the stepper gears.

No. 1,003,221—to Gustav Wagner, Reutlingen, Germany. Granted September 12, 1911; filed July 15, 1909.

**STEERING GEAR**—A steering equipment of the worm block type for automobiles.

4. The patent refers to the combination with a steering wheel of a rotary stem on which the wheel is mounted and having its lower end journaled in a casing. A longitudinally movable member having a screw and nut engagement with the stem and slidably engaging with the casing mentioned is cut away at one side intermediate its ends. Through the aperture in the movable member a stationary tubular member within the rotary stem is secured to the casing, a stationary segment being mounted on this tubular member above the steering wheel; the tubular member contains a rotary shaft connected with a control lever. Through the cutaway portion of the longitudinally movable member passes a laterally extending shaft which is connected with the rotary shaft within the steering stem.

No. 1,001,258—to George W. Dunham, Detroit, Mich., assignor to the Hudson Motor Car Co., Detroit. Granted August 22, 1911; filed March 4, 1910.

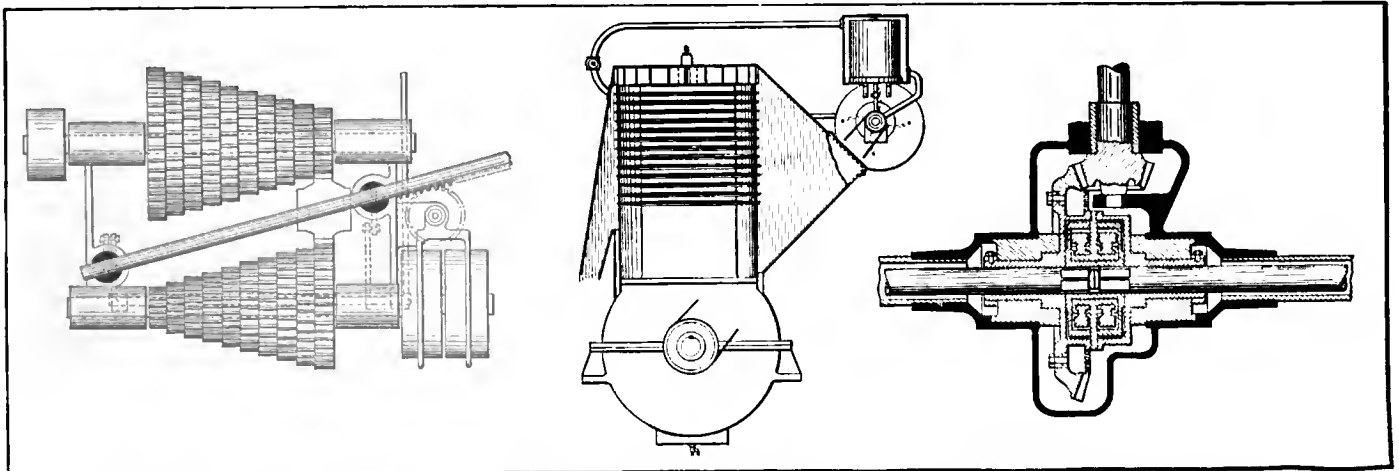

Fig. 1—Wagner variable speed gearing

Fig. 2—Okrassa engine cooling system

Fig. 3—Rogers compensating gearset



# Newest Ideas Among the Accessories

## Norma Bearings

**N**ORMA bearings, which are being manufactured by the Norma Company, Stuttgart, Germany, are now being introduced in the American market

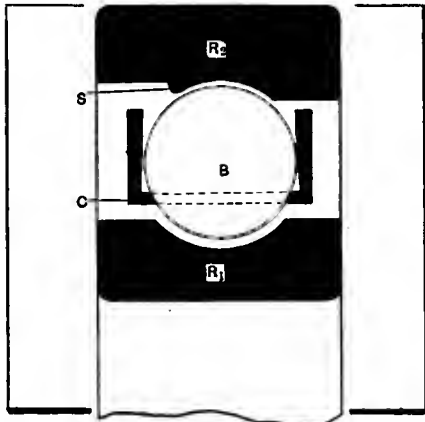

Fig. 1—Section of Norma annular ball bearing

by the Norma Company of America, 20-24 Vesey street, New York City.

The Norma annular ball bearings, illustrated in Figs. 1 and 3, have the outer race  $R_2$  open on one side, permitting of disassembling the bearing altogether. It is possible to mount all parts independently of one another, they being of standard sizes and interchangeable. The outer race with its open side makes it possible to mount the bearing in inaccessible places, either with or without allowance for lateral play.

As the parts of the ball bearing in Fig. 3 show, the outer circumference of the inner race  $R_1$  is shaped with an annular cavity  $C$  into which the balls fit. The cage is of brass, the walls having indentations to accommodate the steel balls which project through openings into the inner race, where they rest in the concave annular space. As the section, Fig. 1, shows, the inside

of the collar is stepped off so as to take up end thrust if necessary. Norma ball bearings are made in standard dimensions for light, medium and heavy service.

The Norma roller bearings are shown in Figs. 2 and 4, and like the ball bearings are made with a high degree of accuracy, using the Hirth minimeter for the manufacture of the parts. The outer race  $R_2$  of the roller bearings is open-sided, giving it the same advantages as those noted in the case of the Norma ball bearing. Short cylindrical rollers  $R$  which take the load are held and guided in a substantial steel cage by means of pins, being secured against skewing. The outer race is provided with a slightly convex track for the rollers; the inner race  $R_1$  is a hollow cylinder, both races being securely fastened when mounted.

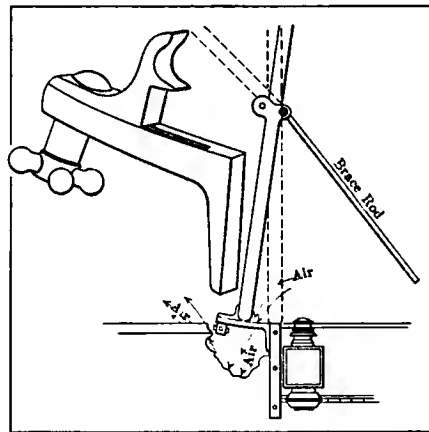

Fig. 5—Cyclone ventilator windshield and special brackets

The shaft of the roller bearing is capable of being axially displaced, but the bearing is not intended to take up thrust.

The dimensions of these roller bearings make them interchangeable with ball bearings of standard measurements.

## Cyclone Ventilator Shield

In Fig. 5 is depicted the Cyclone Ventilator wind shield, made by the Sprague Umbrella Company, of Norwalk, Ohio. The construction of this shield permits of

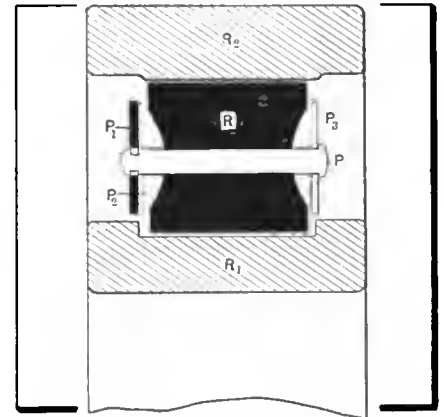

Fig. 2—Section through Norma roller bearing

placing it in such a position that the air current met by an advancing car is deflected below the cowled dash. The shield is attached to the dashboard in the manner shown in the cut, and while the position of its upper portion may be regulated by means of the brace rod illustrated, the entire shield may be moved forward or rearward owing to the special construction of the bracket shown in the upper left portion of the accompanying illustration, Fig. 5. The two feet of the windshield are rigidly fastened to such brackets, two of them being provided, and, as the illustration shows, mounted on a holder securely bolted onto the dashboard. This holder has a guideway cut in it in which slides a finger-wheel serving to hold the windshield in the desired position; it is loosened to move the shield and locked when it is desired to keep the shield in place.

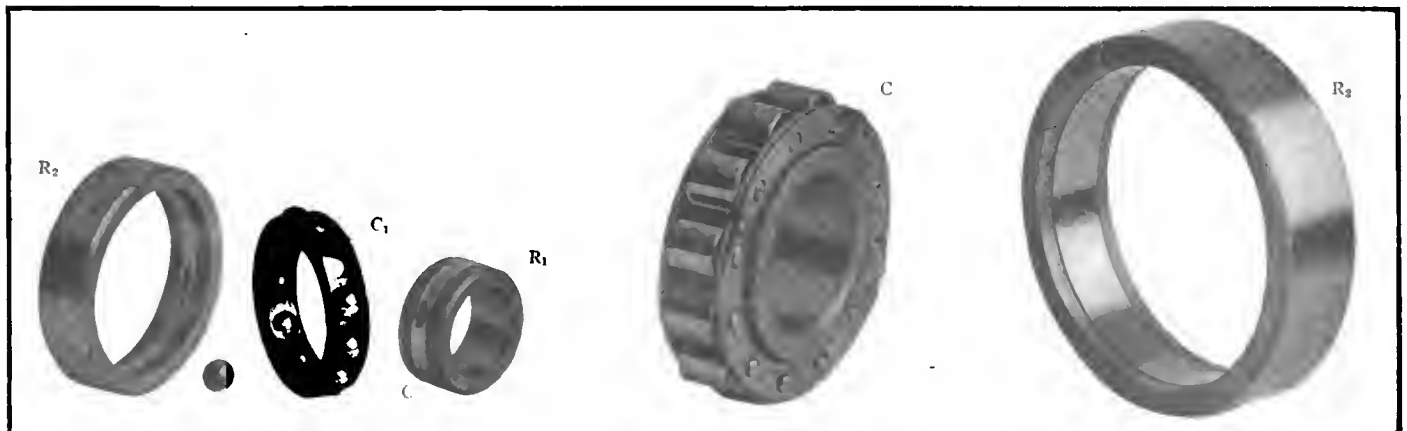

Fig. 3—View of disassembled Norma annular ball bearing

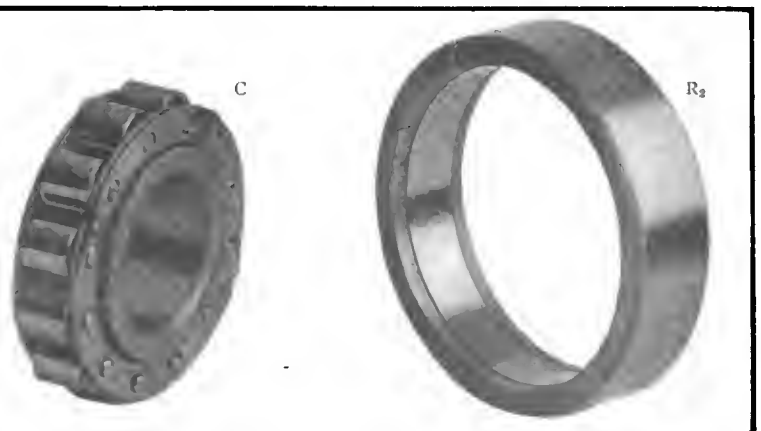

Fig. 4—View of component parts of Norma roller bearing

# THE AUTOMOBILE

## Good Roads, Keynote of Prosperity

Automobile Has Forced Issue of Improved Highways



THE LAST WORD IN BRIDGE CONSTRUCTION AS IT APPLIES TO MODERN GOOD ROADS



**T**RANSPORTATION measures the civilization of the world to-day, just as it has always done since the beginning of mankind. Each successive step upward that has been taken by mankind is founded upon speed and ease and the betterments of each in their relation with communication between more or less widely separated communities or individuals. The automobile is the highest form so far assumed by the idea of transportation, but in order to get the

best results from the motor car good roads are essential.

Next to the automobile itself the most important part of motor-ing is the road. In the broadest possible sense good roads mean prosperity and bad roads mean the reverse.

Of two communities equal in size and natural resources of surrounding territory, the one which has good roads will be found to be far in advance of the one where opposite conditions obtain, in every particular and factor that go to make up human well-being.

The automobile has forced the issue of good roads, as can be readily seen by one sweeping glance over conditions five years ago and as they are to-day.

At a banquet given in the New Kimball, Springfield, Mass., recently, during the inspection of New York and New England highways under the auspices of the Touring Club of America, Logan Waller Page, director of the Office of Public Roads, who acted as toastmaster, said that there were in the United States 2,155,000 miles of road and that \$250,000,000 could be saved annually on the haulage of the three principal crops produced in the country if the roads were improved. On that basis the total



Two-thirds of this road is crowned so stiffly that horses are forced to the right. It is three years old

saving on the single item of agricultural haulage would amount to a staggering sum each year.

That is just one item of the advantages that would follow general road improvement. The others include practically everything that may be grouped as factors in human happiness, health and prosperity.

If the automobile never does anything more than center the attention of mankind on the roads, it has performed a mission that will surely have a high place in the history of civilization.

Five years ago a good country road was such a highway as could be traveled over in wet weather. Outside of a few boulevards and paved streets within the limits of certain cities there was no such thing as pleasure to be experienced in passing over the roads in any sort of a conveyance. To travel 10 miles in one hour behind a good horse would have been considered just cause for action by the authorities pledged to the protection of animals from cruelty,

or from the point of view of a large part of the citizenship, just grounds for the appointment of a lunacy commission upon the driver.

This year practically \$1,000,000 a day has been expended in building and maintaining highways, and in the future a still larger sum *per diem* will be devoted to this prime essential of civilization

State Aid, a system by which the various state governments assist by supervision, direction and by actual money appropriations in the improvement of county and township roads, has been adopted pretty generally throughout the country. The most progressive of the States have gone into the work with earnestness and some of the most astonishing results have been attained.

The federal government is mightily impressed with the importance of good roads, and, according to the annual reports of the Office of Public Roads, hundreds of object lessons in construction and good practice

have been given to scattered communities.

The result of these labors is to be felt in the awakened interest of the general public in the subject of good roads. From every quarter of the land appeals for more education in the matter of road building and maintenance are pouring in upon the Government.

For five years practically every section of the country has been trying to improve its highways. In the East, Massachusetts, New York, Connecticut and New Jersey have made notable progress, but everything that has been done so far may be regarded in a broad sense as experimental.

It was a pioneer movement in which fundamental principles had to be discovered and applied to conditions that were amazingly complex. Some of the earlier specimens of road building in the United States are still in existence, while others have long since disintegrated. The fact that two specimens were made of identical materials and by the same process and subjected to the same volume of traffic was no good reason for the expectation of an equal return of service. It was discovered that slight differences in grades, drainage and the angle of the crown caused one road to go to pieces and the other to "stand up." But, on top of this, it was also found that the road that was destroyed in a single season in one locality proved satisfactory in another.

As a result the highway engineers are still considerably confused as to the lessons conveyed by these experiments. What one may consider as an established principle of road building another will regard as still to be classed among the experiments. The reason for this confusion lies in the variance of conditions covered by the road builders.

The experts and engineers confess frank-



Splendid view of machine used in Massachusetts for spraying hot oil under pressure upon roads

ly that the ideal road has not been found so far in their investigations, and most of them will add "and it is not likely to be found." By this they mean that a standardized and uniform method of road building, suitable for all conditions and all traffic, cannot be discovered.

However, that admission is not nearly as important as it might seem at first glance. The time, money and energy expended in road work have not been wasted. An immense mileage of splendid, serviceable roads has been produced and is now in heavy service.

No man would appear at a formal social function, as a guest, clad in overalls. Neither would he work a pneumatic riveter high in the skeleton of a new skyscraper attired in the costume of the banquet hall. He would not promenade during a blizzard clothed in white duck, and he would not go to Coney Island on the Fourth of July in a bearskin overcoat.

There is a sense of the inflexible fitness of things that prevents the ordinary, sane human being from wearing clothing manifestly unfit for the occasion, time and season. And thus it has been found with regard to roads.

But during the time that these experiments have been carried on the engineers have come by a vast mass of data having a distinct bearing upon the subject. They have been impressed with the necessity for good drainage, so that fine new roads may not wash out on the surface or break through into soft material which had been undermined by water.

In the widest sense good drainage is necessary for good roads. The use of tile pipes to carry off superfluous water has proved out excellently as far as subsurface work is concerned. Of course this is neces-



Culvert building has been revolutionized since the automobile stimulated the good roads movement

sary in only limited degree, but where it has been given an adequate trial it has demonstrated its effectiveness.

After a road has been surveyed, levels and grades established and such preliminary work as drainage has been performed, the next step, according to the conclusions of highway experts, is to lay the foundation. As a general thing, the foundation is spread upon a prepared bed; it may consist of coarse broken rock that has been screened to remove dust and minute divisions of the stone. Trap rock is a popular favorite, but in many cases where road-making material is at hand in quantity almost any other kind of rock is used. Unbroken gravel, screened to the proper size, is also a favorite material for surfacing the roads.

This foundation rock is spread to varying depths upon the prepared bed. These depths range from 4 to 9 inches and in some cases are even less. If the road is to be 12 feet wide the engineer directs that

the lateral center of the road be raised slightly above the outside edges. This rise toward the center is called the crown of the road and serves the purpose of shedding water that falls or runs upon the surface.

It is usually from about one-quarter of an inch to the foot (or 1 1-4 inches at the crest of the crown) to 1 inch to the foot, which in a 12-foot road would produce a crown elevation of 6 inches.

The next step in construction may be the application of tar, heavy oil or some form of binder. This step need not necessarily be taken at this stage of the procedure, but present practice varies so widely that it may as well be referred to here.

The binder may be spread on cold or distributed over the surface under high pressure and at high temperature. Tar naturally requires some heat, but heavy oil may or may not be heated. The results, as far as the heat or its lack are concerned, appear to be about the same.



Fine example of New York highway crossing scientific culvert; note loose surface, which is practically dustless and easy on tires





Excellent example of modern practice in making retaining walls to protect road surfaces

This should be several days at the shortest period or several months if it be possible to keep the road closed that long. When the work is taken up again there should be another oil treatment and the final surface of the road, consisting of peastone or some other material rolled into it to form a monolith, securely bound by the asphaltic oil, or whatever binder is used. Finer material is then rolled into place and the road is complete.

In a general sort of way the procedure as above describes the chief processes of modern road building. Such a road subjected to a reasonable amount of both automobile and horse traffic ought to last many years if properly maintained. In fact, almost any kind of construction is good if repairs are made when needed. There are some roads in Massachusetts that have been down four years and are still in good condition; some of them conform on general lines with the practice outlined above.

It costs about \$400 a year to maintain a mile of properly built country road at

A magnificent example of the application of hot oil under pressure was afforded the visiting road officials during their recent trip through Massachusetts. A complete road outfit was at work making a stretch of improved highway a short distance out of Springfield and the party watched the progress with intense interest. The device that spreads the oil consists of a tractor engine, equipped with roller wheels, so that the surface to be oiled is first subjected to the pressure of the wide rollers. The tractor draws the sprinkling device, which includes a trailer tank wagon and a pump driven by steam for forcing the hot bituminous liquid through a line of flare sprays, directed toward the roadway. The oil is heated to about 220 degrees and is expelled upon the road surface at a pressure of about 80 pounds to the square inch.

About 7 feet in width of road surface can be treated with oil in this manner. After the passage of the machine an examination of the broken rock shows that each individual piece has been covered on all sides with the black, steaming fluid. In this stretch of road the large broken rock had been covered with stone of smaller size and the binder then been applied. Following the passage of the oiling machine, shovelers swept the oiled surface with

gravelly sand. Hand rakes were employed to remove large stones.

Rolling immediately after sanding a new road has proved to be of only mildly debatable utility. The road commissioners



The modern fence is a thing of beauty and utility, being visible at night and nearly indestructible

seemed to agree that, if the crushed stone of various sizes could be laid and the binder applied, it would be better if the road could be allowed to remain undisturbed until the oil had a chance to properly penetrate.

high efficiency. Thus the cost of maintaining 100,000 miles of excellent highway, such as some of the roads traversed by the inspection party, would be \$40,000,000 a year.

It has been estimated that 100,000 miles of perfect roads would save much more than their maintenance cost each year in actual money, thus leaving the enhancement in value of farm property; the improvement in living conditions in districts that are now considered to be isolated; and the sheer pleasure of using the roads for all purposes, as clear profit.

Among the associated problems that are intimately connected with road building are bridge and culvert construction, guttering and ditching, as well as the erection of fences to guard the right of way. Of the first of these incidents to road making nothing need be said at this time, as the engineering problems involved belong to another school. There has been a revolution in culvert construction within recent years. Where a small stream is to be



The small road roller and drag that are used in preparing roadbeds for their top dressing



crossed and the spans not sufficient in size to require a real bridge the road engineers of to-day span the stream with a concrete culvert. This is securely founded and then built much the same as was its predecessor, the old stone culvert. The difference between the ancient and modern bridge of this description lies in the latter's strength, beauty and utility, which is about as much as can be said for anything that is made with human hands.

In any hilly country culverts are very frequently necessary and in Massachusetts there are literally hundreds of them included in the highway system. Some are as large as small bridges, while others are only large enough to allow the seepage of a stream a few inches in width.

Gutters are used largely where the prepared roadway extends the full width of the highway. Their use will probably be much more extended in the course of a few years, when the art of road making has progressed one step further. The best examples of guttering are found within



One type of curbed and guttered highway that is probably a good example of the road of the future

place such position has a tendency to prevent rotting by forcing the rain and melted snow to drain away and secondly no tramp has ever been able to solve the problem of sitting on the upturned edge.

into a ditch or off a culvert because of missing the road that is protected by them.

The chief lessons that have been learned in the past 5 years of experimentation and trial are these: The importance of maintenance; the significance of the angle in construction of the crown; the width and depth of road material, and the advantages that attend separation of the various classes of traffic.

It has been shown that nearly all of the methods of road building are good if the roads are maintained, and New York State has grasped the meaning of the lesson with a tremendous grip. There are some new highways in the State that are under the patrol system in more perfect form than it has assumed anywhere else in the country. This system consists in stationing a man in each 6-mile stretch of the highway under patrol. Material for mending the road is placed at intervals along its whole length and the man is furnished with a horse, tank-wagon and tools. It is his duty to keep his 6 miles of highway in perfect condition at all times.

As is shown in three of the illustrations, this process is perfectly practical. The man keeps on the road every working day in the year. When he finds a spot that gives signs of raveling he picks out the



Old-style fences such as this one are out of place on the modern road and dangerous to traffic

the limits of some of the cities. Classed along with the stone gutters are the retaining walls, where cuts into the sides of hills have been necessary. They both serve the same purpose in different ways by protecting the road surface.

There has also been marked progress in the building of fences at dangerous points along the highways. The old style included nearly everything in the way of a fence from the proverbial snake and rider to dangerous barbed-wire; but the modern examples, such as may be found along any of the recently improved roads in New York and New England, are businesslike structures made with the rail in the form of a 6 x 6 beam, one angle of which is pointed upward and the opposite angle is set into sockets in the posts. These fences are whitewashed and the joints between the beams are covered in some sections with pieces of tin to protect the wood from the action of the weather. The reason for pointing one angle of the beams upward is twofold. In the first

The whitewash is an excellent idea as it helps the traveler to keep the road at night and warns him of possible dangers. These fences seem to shine out of the darkness and no cautious traveler ever need plunge



Tractor roller, drawing hot oil tank and pressure oil-spraying machine

damaged surface and resurfaces the spot. This may require him to dig clear into the lower strata of the road surface and the replacement of all the smaller material that was bound in originally by the builders. Then he oils and surfaces the spot, using tamper and rolls, and when he leaves it the repaired place is hard to find.

It has been found that the patrolmen take a great pride in the character of their work and seek to excel others employed in the same line. If the cost of maintenance is placed at \$400 a mile per year, and the material costs the State \$150 a mile per year, the income of the patrolman from his 6 miles of highway would exceed that of the average skilled artisan.

The result of the system is delightful to the automobilist who is fortunate enough to travel over patrolled roads.

Next among the cardinal lessons that have been learned is that which has to do with the angle at which the crown of the road should be constructed.

According to Frank D. Kemp, of the



When the horseshoe calks penetrate the macadam, the end of the road is in sight:

Mr. Kemp drew his conclusions from observing several stretches of State road under his personal supervision. One typical piece of highway was crowned in the proportion of about three-quarter inch to

traffic and as a result the wagons proceeded along the side of the improved roadbed. This caused considerable raveling of that edge, but it left the high-crowned road to the exclusive use of the automobiles. At this particular point several important transverse roads lead into the main highway, and for a space of 6 miles this single road represents the only artery of travel to several populous local centers as well as the through travel. The road was improved 3 years ago and has not been touched since.

Of course, where the horses and wagons have broken down the edge of the macadam, the damaged surface extends well toward the center of the crown, but where the cars run the road is in excellent condition. This proves to Mr. Kemp that automobiles operated within the speed limit are not an important factor in wearing out the roads used only by themselves.

But it is a different story where the travel is mixed. So far in the progress of good country road building nobody has discovered a surface that will withstand heavy mixed traffic. Of course, granite block laid in concrete will support anything that has ever been devised in the way of traffic, but aside from the expense of such pavement its disadvantages are too appar-



Note the effect of horse traffic on this newly repaired surface

Massachusetts State Highway Commission, the travel of automobiles alone does not wear out road surfaces with anything like the rapidity of destruction that follows horse travel, or, worst of all, the combined effects of horse and automobile travel. It has long been recognized that the horse cannot draw a load over a road that is steeply crowned, especially in wet or cold weather. If the proportionate rise toward the center of the highway exceeds one-half inch the horse has his troubles in using the road. He slips and flounders from side to side and makes a bad job of it when the surface is wet or frozen. With only a slight rise in the crown the horse does well enough.

On the other hand, the road crown, even as stiff as is represented by 1 inch to the lateral foot will not stop the motor car. As long as the grades are not too heavy and the crown is not so high and pointed as to strike the underpinning of the car, the automobile can use such a road to advantage.

the foot. This road was 12 feet wide; consequently the crown in the center was 4 1-2 inches higher than the outer edges of the roadbed.

This proved to be too much for horse

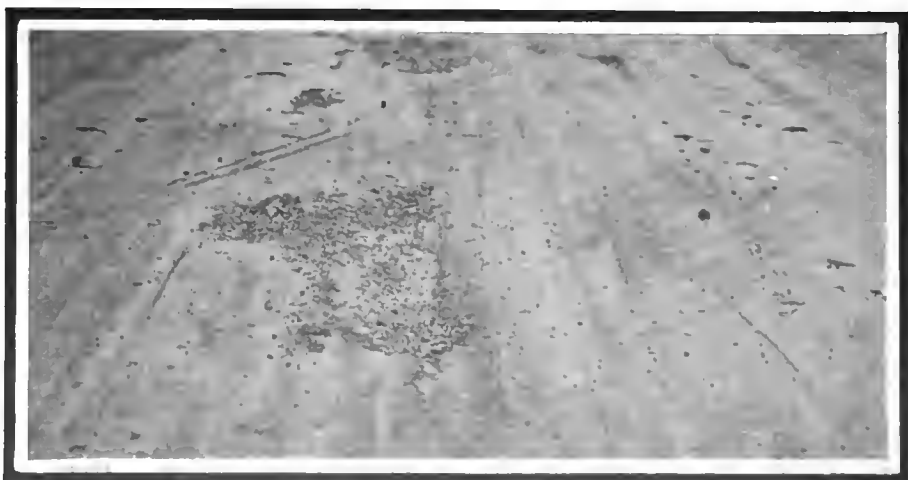

Where a calk wound has allowed water to penetrate, causing destruction of the road surface



One of New York's highway patrolmen working to keep his section in good condition

ent to dignify by consideration. The problem is country roads, and so far the mixed traffic of horses and automobiles has proved too strenuous for existing types, unless some such system of maintenance as the patrolmen of New York may be expected.

There are literally thousands of examples of the truth of this in each of the New England States. Given a stretch of highway, constructed of approved material under approved methods, and if the crown is low enough to admit horse traffic along with the automobiles the life of that road is short. The effect of horse traffic is this: The calks with which horseshoes are equipped, to prevent the animal falling on slippery surfaces, dig into the new road surface. This is necessary from the horse's point of view, but exceedingly bad as far as the road and the automobilist are concerned. The effect of the calks is to loosen the surface, and when this process takes place in the fall it spells disaster to the road.

The rain and snow descend upon the road surface and after soaking into it come to a stop above the waterproof oil and tar except in such spots as have been pierced by the calks. There the water trickles through to the under layer of the

road material and in the course of a considerable wet spell the lower strata adjacent to the calk wound are filled with water. Then when frost strikes hard and deep the damage is done. Water expands nine



Material for resurfacing and barrels of oil are distributed along patrolled highways in New York

per cent. of its volume when converted into ice, and road material is not strong enough to withstand the fierce pressure of the swelling ice. There can be but one result, and that is for the surface of the road

to bulge up, torn from its binder and separated into its integral parts.

When the Spring comes on and the roads dry the material pushed out by the frost is caught by the rapidly turning wheels of automobiles and soon decorates the surrounding country in the form of dust or is rolled into the ditch and carried away by the next rain. In its place is a hole that may cause a puncture or blow-out at any time and which gives the springs a twinge every time a vehicle passes over it. Let the process be repeated in the same place and it would surprise no road commissioner to find a hole there that penetrated to the roadbed.

In a word the lesson learned from this phase of road building is that it is undesirable at the present stage of the art to allow automobiles and horses to use the same country roads. But as this is impossible to bring about under existing conditions, and as no road material will stand up under the mixed traffic unless carefully and constantly patrolled, the conclusion

is either to install a patrol system or to build the roads wider, with the crown to one side of the center. If the crown were high enough this would be sufficient to bar horse traffic from that side of the road. Then the question of keeping the automobiles on the high crowned part would present quite a problem.

The engineers believe that the most durable and satisfactory road of the immediate future will be one fully 9 inches deep and extending from one side of the right of way to the other. The road may be of almost any kind coming within the general classification "water-bound" and should be curbed and guttered. If some means could be devised to separate the automobiles from the horses, by crowning one side of the road higher than the other, or by making the apex of the crown approximately one-third of the distance from the right curb, or by putting in a low, stone curb, one-third the lateral distance from the left curb, the problem might be solved.

(Continued on page 551.)



The patrolman is obliged to go through all the processes of road building and repair

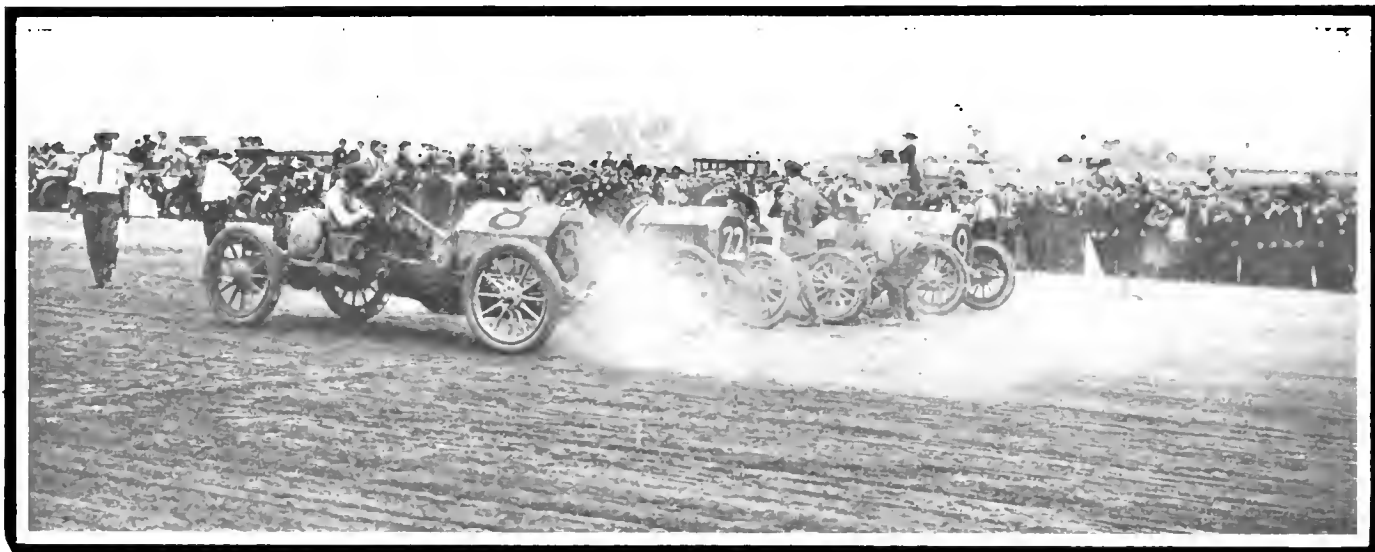

Start of the 25-mile race—Klinekar, Buick, Simplex, Klinekar—won by the Simplex, driven by De Palma

## Simplex and Cino Win at Point Breeze

PHILADELPHIA, Sept. 25—De Palma, piloting a Simplex at the Point Breeze meet Saturday, smashed the mile track record of 58 4-5 seconds in the record trials, setting a new mark of 57 7-10 seconds; won the 10-mile open race, carded as Event No. 5, incidentally reducing the 5-mile track record of 5 minutes 45 seconds to 5 minutes 27 seconds, and setting a new mark of 10 minutes 42 seconds for the 10 miles; romped home a winner in the following event, a 5-mile free-for-all race, and finished up a good afternoon's work by winning the 25-mile special race with ease. In a special event, free-for-all handicap, however, he was forced to be content with third position, the winner of the contest having nearly a minute's start, almost a mile, a lead De Palma was unable to overcome.

Profiting by the unfortunate circumstances attending the race meet at Syracuse, N. Y., last Saturday, exceptional care was taken to avoid even a semblance of repetition of anything of the kind. The regular force of police that usually take care of the crowds was supplemented by extra forces on motorcycle, mounted and on foot, and spectators were roped off at a respectful distance from the track to prevent the more venturesome from letting their enthusiasm get the upper hand and straying too near the track for safety. As a consequence the races were void of the slightest mishap, without detracting in the slightest from the comfort and enjoyment of enthusiasts. The

meet was the first one ever conducted by the Philadelphia Automobile Trade Association and the Contest Committee of that organization made a perfect job of it.

Only one event originally scheduled failed to come off—the ten-mile match race between Ralph De Palma, Simplex, and



Cino, driven by Raimey, which won two races in impressive style

Louis Disbrow, Opel, due to the latter's machine being crippled while in transit to the track.

The record trials brought out three competitors—J. R. Raimey, Cino car, a newcomer to Philadelphia; Erwin Bergdoll, Benz, and Ralph De Palma, Simplex. The first two mentioned failed to cross the tape under the minute mark, and De Palma lowered the mark of 58 4-5 seconds established by Bob Burman in the Blitzen Benz recently.

Four cars competed in the second event, 5 miles. This race was notable for the fact that it marked the reappearance of Willie Haupt in racing. Haupt drove a Buick, but the car worked badly and he was forced to quit early. The race subsequently developed into a two-car affair, the E-M-F, Jack Tower driving, winning, with the Metz "Humming Bird" runner up. The next event was a repetition of the second insofar as the winner was concerned, the E-M-F again passing the judges' stand in the lead, the Klinekar, W. D. Morton driving, a good second, and the Abbott-Detroit third.



Line-up in the 10-mile race—Benz, Knox, Simplex—won by the Simplex



Only two cars finished in the fourth event, the Cino, J. R. Raimey driving, and Willie Haupt in a Buick. The former car started out in the lead and never relinquished it, although the Buick was always a dangerous factor and was in a good position to jump into the lead upon the slightest sign of a let-down on the part of the Cino. The latter won by about 100 yards.

Event No. 5, a special race with two starters, De Palma, Simplex, and Bergdoll, Benz, was provocative of daring racing and a great deal of excitement from the fact that the two machines were rarely more than 10 yards apart at any time during the 10 miles. A Knox car that had been entered in this event was ruled off on account of bad tires. It was during this race that De Palma set a new mark of 5.27 for 5 miles and 10:42.07 for 10 miles. Bergdoll also was well under the old record of 5.45 at the 5-mile mark, and although the crowd rooted hard for him to win, he finished a scant 3 seconds too late.

The Simplex also captured the following event, a free-for-all,



Start of \$1000-and-under race—Hupmobile, Buick, Metz, E-M-F—won by latter

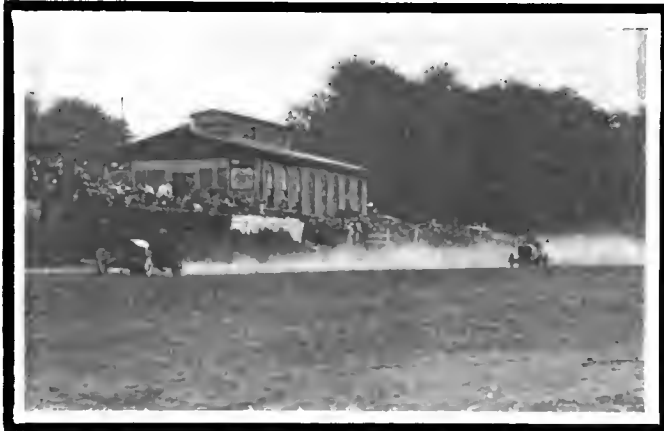

Simplex (De Palma) finishing ahead of Benz (Bergdoll) in 10-mile event 5 miles, with four starters, although it had its work cut out from the start.

In a free-for-all 10-mile handicap George Parker, a Philadelphian, driving an Ohio car, was returned a winner against four other contestants. Parker made good use of his allotted handicap of 55 seconds and after the fourth lap was never headed. The other cars in this event were Simplex, De Palma; Buick, Haupt; Klinekar, Seachrist; Cino, Raimey, and another Klinekar.

Two 25-mile races were an important feature of the afternoon, in one of which De Palma scored his third win of the day, the Cino being the winner in the other.

**SUMMARIES OF THE POINT BREEZE RACES**  
Record Trials, 1 Mile

Pos.	Car.	Driver	Time
1	Simplex	De Palma	57.70
2	Cino	J. R. Raimey	1:03.76
3	Benz	Erwin Bergdoll	1:04.70
<b>Class E, for Cars \$1,000 and Under—5 Miles</b>			
1	E-M-F	Jack Tower	6:30.40
2	Metz	H. B. Baker	8:59.80
Hupmobile and Buick did not finish.			
<b>Class E, for Cars \$1,500 and Under—5 Miles</b>			
1	E-M-F	Jack Tower	5:53
2	Klinekar	W. S. Morton	6:03
3	Abbott-Detroit	M. Roberts	6:06.40
<b>Class E, for Cars \$2,000 and Under—10 Miles</b>			
1	Cino	J. R. Raimey	11:35
2	Buick	Willie Haupt	11:59.41
<b>Class E, Special Event, 451 to 600 Cubic Inches—10 Miles</b>			
1	Simplex	Ralph De Palma	10:42.07
2	Benz	Erwin Bergdoll	10:45.18
<b>Class D, Free-for-All, Non-Stock Cars—5 Miles</b>			
1	Simplex	Ralph De Palma	5:24.18
2	Benz	Erwin Bergdoll	5:26.05
3	Cino	J. R. Raimey	5:28.45
<b>Class E, Special Event, Free-for-All, Handicap—10 Miles</b>			
1	Ohio	George Parker	11:07
2	Buick	W. Haupt	11:52
3	Simplex	De Palma	11:53
Handicaps: Ohio, 55 seconds; Buick, 1 minute 10 seconds; Simplex, scratch.			
<b>Class E, for Cars 161 to 300 Cubic Inches, Non-Stock—25 Miles</b>			
1	Cino	J. R. Raimey	28:25.18
2	Ohio	George Parker	28:28.91
3	Klinekar	E. Seachrist	30:11.95
<b>Class C, Special Event, 25 Miles, 301 to 600 Cubic Inches</b>			
1	Simplex	De Palma	27:22.55
2	Klinekar	Morton	31:46.16
3	Buick	Haupt	32:52.25



Despite the mediocre programme Philadelphians poured into Point Breeze track by the thousands. Looking toward clubhouse from paddock





On the second day of the Chicago Truck Run the contestants stopped for several hours at the Stock Yards for demonstration purposes

The Big Saurer broke through a bridge on the third day of the test

# 20 Clean Scores in Chicago Truck Run

CHICAGO, Sept. 25—In a nutshell, the story of the three-day truck demonstration of the Chicago Motor Club is this: Thirty-two power wagons started; twenty-eight finished; four were penalized in the road test; four more went out under the technical examination; one was penalized in the brake test and two in the clutch test, leaving twenty of the contesting cars with perfect scores in every department.

So far as the road work was concerned, the test came to an

end Wednesday night, when the run to Chicago Heights and return was finished. Then the trucks were garaged until yesterday, when the technical committee inspected them. The brake and clutch tests took place in the alley in the rear of the White garage. Paced by a pleasure car, the trucks were called upon to speed down the alley at the limit of their class pace. Each was given 50 feet in which to stop and every foot over that meant 1 point. Only one of the power wagons failed to do this, that being No. 3 Clark, which slipped 3 feet past the line while the hand brake was being used.

An interesting feature in connection with this test was furnished by the horse-drawn rig, No. 13, which made the trip to Chicago Heights and return in 2 days, while the motors made it in 1 day. It was decided by the technical committee that No. 13 should go through with all the formalities so far as possible and the two horses were driven into the alley and put to the brake test. Of course the driver could not use brakes, for in Chicago horse-drawn rigs do not have them, but the horses were called upon to show in what distance they could stop at a walk and again at a trot. Gravely they went through the stunt and in the walk they had the wagon at a standstill in 15 feet and in the trot they checked the vehicle in 28 feet.

The clutch test came next. In this each truck was called upon to demonstrate the condition of its clutch by facing an 8-inch curb. With the motor running at its maximum speed the clutch was dropped in and either the rear wheels had to spin or the motor kill to escape penalty. Two failed to come up to the requirements, one being No. 5 Sampson and the other No. 14 Adams, each being given 5 points. Of the three penalized in these two departments, two already had suffered on the road, the Adams and the Sampson, but the Clark lost its chances of a perfect score.

Following this the trucks were garaged and turned over to the technical committee for a final inspection. This was not anywhere near as rigid as in the case of the pleasure cars, the committee contenting itself by looking only at the essentials—the running gear, transmission mechanism and steering apparatus. No search was made for loose nuts or bolts or things of that sort which ordinarily bring penalties in pleasure car runs.

This examination robbed three of the cars of perfect scores. The greatest sufferer was No. 3 Clark, to whose score, already blackened by the 3 points in the brake test, were added 105 points—5 points for a broken spring leaf and 100 points for a

## COMPLETE RESULTS OF THE CHICAGO TRUCK RUN

Division 2-K, 501-1000 Pounds								
No.	Car.	Hand Brake	Emergency Brake	Clutch	Gear set	Road	Technical	Total
1	Mercury	0	0	0	0	0	0	0
2	Mercury	0	0	0	0	72	0	72
Division 3-K, 1001-1500 Pounds								
4	Buick	0	0	0	0	0	0	0
6	McIntyre	0	0	0	0	0	0	0
7	Crown	0	0	0	0	0	0	0
5	Sampson	0	0	5	0	10	0	15
8	Krickworth	0	0	0	0	0	100	100
3	Clark	0	3	0	0	0	105	108
Division 4-K, 1501-2000 Pounds								
9	Clark	9	0	0	0	0	0	0
10	Clark	0	0	0	0	0	0	0
11	LeMoon	0	0	0	0	0	0	0
12	Little Giant	0	0	0	0	0	0	0
16	Lauth-Juergens	0	0	0	0	0	0	0
20	Chase	0	0	0	0	0	0	0
17	Lauth-Juergens	0	0	0	0	0	10	10
14	Adams	0	0	5	0	6	0	11
18	Decatur	0	0	0	0	0	30	30
15	Swanson	Withdrawn						
19	Monitor	Withdrawn						
Division 5-K, 2001-3000 Pounds								
21	McIntyre	Withdrawn						
Division 6-K, 3001-4000 Pounds								
22	Stegeman	0	0	0	0	0	0	0
23	Reliance	0	0	0	0	319	0	319
Division 7-K, 4001-5000 Pounds								
24	Mais	0	0	0	0	0	0	0
Division 8-K, 5001-7000 Pounds								
25	Alco	0	0	0	0	0	0	0
26	Old Reliable	0	0	0	0	0	0	0
27	Durable Dayton	0	0	0	0	0	0	0
28	Pope-Hartford	0	0	0	0	0	0	0
Division 9-K, 7001-10,000 Pounds								
29	Saurer	0	0	0	0	0	0	0
30	Stegeman	0	0	0	0	0	0	0
31	Sampson	0	0	0	0	0	0	0
32	Alco	Withdrawn						
Division 10-K, 10,001-15,000 Pounds								
33	Saurer	0	0	0	0	0	0	0



Not a few of the bridges had to be taken very gingerly by the heavier vehicles

The brake tests were held in a brick-paved street where the crowd was small and traction excellent

broken brake connection. No. 8 Krickworth was penalized 100 points—75 for a broken spring horn and 25 for a bent tie rod. The Krickworth had a good excuse, all the trouble being brought about by a skid into the ditch. Another perfect score went when No. 17 Lauth-Juergens was discovered to have two broken spring leaves, also caused by a ditch adventure. No. 18 Decatur was given 30 points for two broken spring shackles.

No. 1 Mercury won class 2K and its only opponent was another Mercury. No. 22 Stegeman won class 6K, in which the Reliance was the other contestant. No. 24 Mais had a walkover in class 7K, while No. 33 Sauer was alone in 10K.

Class 3K returns three cars as cup winners, No. 4 Buick, No. 6 McIntyre, and No. 7 Crown. In 4K No. 9 Clark, No. 10 Clark, No. 11 Le Moon, No. 12 Little Giant, No. 16 Lauth-Juergens and No. 20 Chase are tied with perfect scores. None finished in 5K, the McIntyre, the only starter, having quit the second day when it damaged its steering gear in a collision with a beer wagon. Class 8K, for the 2 1-2 and 3 1-2 ton trucks, was remarkable in that all four of the cars had perfect scores.

In Class 9K, in which four 5-ton trucks started, three went through with perfect scores, those being No. 29 Saurer, No. 30 Stegeman and No. 31 Sampson; No. 32 Alco, the other starter, was eliminated the second day by a burned-out bearing. No. 33 Sauer had a walkover in the big class.

The last day of the test, Wednesday, resulted in the elimination of only one perfect score, that being No. 5 Sampson, which was penalized 10 points for replacing a bolt in the torsion rod.

The routes included Whiting and Hammond, Ind.; Evanston, Oak Park and Chicago Heights, Ill.; but were largely within the limits of Chicago.

Lessons Drawn from the Run

The experience gained in the traffic zone within the loop appealed to the makers of 1-ton trucks more than to builders of 2-ton, 3-ton, 5-ton or 6.5-ton trucks, because the big trucks can make as rapid headway through traffic as the 1,000-pound delivery wagon.

The big trucks ran on a slow schedule of 5 or 6 miles per hour; this is the average speed through zones of congestion; but the smaller vehicles, running on a schedule of 11 miles per hour, found it impossible to average this speed in the traffic zones. They were held back at every corner by the policemen who allow the traffic to go one way at each crossing for a period of 1 minute and then let it go in the opposite direction.

Before the experience of one day in traffic, many of the makers of smaller trucks were guaranteeing as high as 15 miles per hour anywhere in the city for their trucks; but after 1 day of official demonstration they were willing to cut the guarantee to 10 miles per hour. One maker said that he would not guarantee over 10 miles per hour on his vehicles for con-

gestion zones. It may be noted that when these little trucks got into semi-traffic-congestion areas, they were able to make an average of 15 miles per hour with ease.

This speed experience is one of the most valuable of the demonstration. Speed has been going against the commercial vehicle for months. The inexperienced salesman will guarantee any speed to 25 or 30 miles per hour and in addition would guarantee the truck for life. Such would-be guarantees are absurd;

RESULTS OF BRAKE TESTS

No.	Car	Foot	Hand
1	Mercury	18	25
2	Mercury	32	23
3	Clark	28	53
4	Buick	20	27
5	Sampson	24	35
6	McIntyre	41	32
7	Crown	29	49
8	Krickworth	27	31
9	Clark	28	20
10	Clark	43	30
11	LeMoon	24	25
12	Little Giant	45	50
14	Adams	35	40
16	Lauth-Juergens	25	34
17	Lauth-Juergens	24	27
18	Decatur	18	36
20	Chase	26	25
22	Stegeman	11	15
23	Reliance	10	23
24	Mais	4	13
25	Alco	7	10
26	Old Reliable	7	13
27	Durable Dayton	10	13
28	Pope-Hartford	11	16
29	Saurer	9	13
30	Stegeman	11	11
31	Sampson	8	20
33	Saurer	4	3
13	Horse	Walk	Trot
		15	28

WEIGHT IN POUNDS

No.	Car	Empty			Loaded			Total Carried
		Front	Rear	Total	Front	Rear	Total	
1	Mercury	955	955	1810	1040	1830	2850	1040
2	Mercury	875	975	1840	1000	1845	2890	1050
3	Clark	1350	1875	3175	1500	3310	4770	1595
4	Buick	1400	1325	2680	1830	2600	4460	1780
5	Sampson	1515	1385	2860	1770	2630	4365	1505
6	McIntyre	1475	1475	2830	1675	2530	4225	1395
7	Crown	1365	1425	2680	1610	2635	4335	1655
8	Krickworth	1635	1135	2710	1890	2490	4425	1717
9	Clark	1635	1800	3400	2000	3540	5500	2100
10	Clark	1700	1900	3520	2310	3460	5640	2120
11	LeMoon	1575	1850	3400	1750	3770	5480	2080
12	Little Giant	1350	1500	2780	1780	3020	4860	2080
14	Adams	1925	1925	3785	2025	3770	5860	2075
16	Lauth-Juergens	1875	1515	3330	2195	3205	5430	2100
17	Lauth-Juergens	1995	1600	3500	2210	3460	5620	2120
18	Decatur	2055	1950	3940	2295	3740	5990	2050
20	Chase	1250	1425	2630	1670	3210	4700	2070
22	Stegeman	2350	2825	5050	2560	6760	9320	4270
23	Reliance	3500	2525	5830	4530	5534	9975	4145
24	Mais	3030	3720	6720	2970	8950	11835	5115
25	Alco	4550	4430	8745	6575	9470	15900	7155
26	Old Reliable	3510	4680	7975	4460	10770	15165	7190
27	Durable Dayton	3925	3550	7450	5365	8170	13510	6060
28	Pope-Hartford	3450	4040	7330	4330	9390	13440	6110
29	Saurer	2670	4250	6790	3600	12500	15930	9140
30	Stegeman	3250	5200	8215	3540	13000	16340	8125
31	Sampson	4500	6355	10800	6375	14815	20900	10100
33	Saurer	2850	5640	8380	4100	17455	21525	13145



Contestants held up trying to get around a gang of street repairers

they injure the business; they spoil sales instead of making sales; and they will eventually put the dealers out of business.

The one trouble which evidenced itself during the demonstration was that of hard tires. The solid rubber tire is imperative for heavy trucks, say from 3 tons up, and the trouble with it is in its coming off. When a solid rubber tire comes off, the wheel has to go to the tire repair shop before a new tire can be attached. The driver cannot put on a new tire on the road the same as with a pleasure car. Should a 5-ton truck lose a tire when 5 or 6 miles from the point of delivery, it would be necessary to get another wheel to the truck. This means that the truck owner should carry extra wheels, shod with tires, in stock. To get the wheel out to the truck takes time and time means money. From this demonstration it would seem that the demountable solid rubber tire is the only solution of the problem. It should be easier to supply a satisfactory demountable rim for a truck than for a touring car, because a solid tire is used. Some of the makers have such tires and rims but more of them are needed. On a 5-ton truck fitted with dual solid rear tires, the wheel with its two tires will weigh anywhere from 700 to 840 pounds. To carry an extra wheel around on the truck means quite an extra load in itself. To carry a single rubber tire with its rim would not be much over one-quarter of such a load. For trucks in which the motor is carried under a hood, the same as in a touring car, a single front tire of the same size as one of the dual rears could be used, so that one extra tire, carried on the truck, would be enough for all exigencies. On



Reliance truck plugging through mud one mile out of Chicago Heights

the other hand where the motor is carried under the seat, the seat being up in front, a heavier front tire is needed and this would make it necessary to carry two sizes of spare tires, which would be much preferable to carrying two extra wheels.

The truck must operate on schedule. If it does not, it loses money for the owner. It delays the shipment of merchandise to out-of-town places; it may cause cancellation of orders; it may do a dozen other things, solely because it loses a tire and has to be hung up on the street until a new wheel arrives.

From the table of truck weights, printed on another page of this issue it is apparent that some of the trucks are very heavy for the useful load they carry.

Examination shows that for loads of 1-ton and under, the truck weight approximates one-third more than the load it carries. In some of these, the truck weight is almost double that of the load capacity of the machine. In the 2-ton and 2.5-ton trucks, the truck weighs about 25 per cent more than the load it can carry. In the 3-ton and 3.5-ton classes the truck weight is not more than 14 per cent in excess of the load carried. As the truck capacity increases the weight of the load and the weight of the truck approach one another, thus the Sampson No. 31 weighs 10,800 pounds and carries a load of 10,100, or 700 pounds less than its own weight. The two Saurer trucks were the only examples of the truck being much lighter than the load carried, thus the 4.5-ton truck, No. 29 weighed 6,790 and carried a useful load of 9,140, or more than 40 per cent in excess of its own weight. Again in the 6.5-ton vehicle, No. 33, the



McIntyre, No. 6, which finished with clean score in Division 3K

truck weighed 8,380 and carried 13,145 or more than 50 per cent over its own weight.

Many of the trucks are too heavy for the work they do. Much weight can be cut out in places. It takes motor power to carry the truck's own weight along, and if 2,000 pounds can be cut off the weight of a 5-ton truck, it should make the carrying capacity of that truck commensurately greater; it should reduce the tire upkeep on that truck; and it should reduce the general wear and tear. It is poor economy to load up with heavy parts if smaller ones will do. If ordinary steels will not give adequate strength without using enormous mass, then the natural solution is to use better steels and cut down the size of the parts. There is much to be done in this respect.

With the small delivery the proportion of car weight to load will never be as favorable as with the big truck, on the ground that a small truck requires almost as many pieces in its make-up as a big truck does. There is not much difference in the weight of a magneto needed on a small car and that needed on a big truck. The same holds true with many other parts.

As the brake table on another page shows, most of the contesting trucks were well braked. The rules allow 50 feet as a stopping distance in the brake tests. This is too much. For trucks of 5-tons or over and traveling at 6 miles per hour, 20 feet is distance enough. Some of them stopped in the amazing

distance of 3 feet, others in 4, 7, 8, or 9 feet, with only one set of brakes used at once. Trials were not made to show what distance would be required when both sets were used together.

In the brake tests, with lighter trucks, the distances ranged from 20 to 50 feet. Many of the 1-ton trucks using large wheels, but not large enough drums, should have larger brakes.

The inadequacy of the brakes on the lighter vehicles was proven by the number of accidents these vehicles suffered by running into street cars, heavy horse trucks and into one another. Many of the accidents were due to the brakes locking the wheels and the truck skidding on the car tracks into street cars. This suggests the necessity of additional brakes.

When being operated in congested city traffic zones a 1-ton truck traveling 10 miles per hour should be able to stop in a distance of 20 feet, and if brakes cannot be fitted to accomplish this, then some additional form of brake, which would contact with the street pavement, might be introduced.

Locking of the wheels is the most dangerous factor in a brake for a solid tire and the designers should aim at a brake which will take hold gradually and not lock the wheels. Once the wheel, shod with a smooth solid rubber tire, is locked it loses obedience to all laws and simply skids. If in a street car track it will skid along a terrific distance; and if on a pavement it will wreck itself against the curb or some other vehicle. Larger brake drums will aid in accomplishing this end. The maker



A sample of the street conditions met with in South Chicago on the first day

### Georgians to Tour State and See Races

ATLANTA, GA., Sept. 25—Final plans for the Tour Around Georgia were made at a meeting held here recently. According to present plans the tour will start November 22 and last 11 days. Only 6 days, however, will be spent on the road. The rest will be in Savannah where the tourists will be on hand for both the Grand Prize and the Vanderbilt races.

The exact list of prizes has not been announced, but already \$3,200 has been subscribed for this purpose. The city of Savannah has made a special prize offer of \$600 to the town or city sending the greatest number in proportion to its population.

The scheme is to start the tour from Atlanta, November 22. The first day's run will be to Americus, 149 miles, with a stop at Zebulon for lunch. The next day the tourists will journey to Valdosta, covering 137 miles. There will be a stop at Albany and a lunch at Thomasville. The third day's touring will get the tourists to Baxley, 133 miles; a noon control at Waycross.

The exact route of the fourth day's run, which is to Savannah, will be the subject of further scouting. The route is 105 miles.

In Savannah the tourists will have 5 days to view the two big races and to tour over Chatham County's excellent roads. After the running of the Grand Prize the tourists will take up their journey again. The first noon control out of Savannah will be Statesboro and the night control Dublin, 125 miles. The following morning the tourists will run to Macon and that night will complete their journey to Atlanta, 152 miles.



Little Giant, No. 12, came through the entire test without a single demerit

must not be satisfied with a brake that will simply lock the wheel, this is not the acme of brake perfection by any means, it must do more—apply gradually and retard the wheel, without destroying that friction condition between tire and street surface.

#### MOTOR STATISTICS OF THE COMPETING VEHICLES

No.	Vehicle	No. of Cylinders	Bore	Stroke
1	Mercury	2	4 3/4	4
2	Mercury	2	4 3/4	4
3	Clark	4	3 3/4	5
4	Buick	2	4 1/2	5
5	Sampson	2	4 3/4	4 3/4
6	McIntyre	4	4 3/4	5 1/2
7	Crown	4	3 3/4	4 1/2
8	Krickworth	2	5	5
9	Clark	4	3 3/4	5
10	Clark	4	3 3/4	5
11	LeMoon	4	4	4
12	Little Giant	2	5	4
14	Adams	4	3 3/4	5
15	Swanson	2	5 1/4	4 3/4
16	Lauth-Juergens	4	4	4
17	Lauth-Juergens	4	4	4
18	Decatur	4	4	4
19	Monitor	2	5 1/4	4 3/4
20	Chase	3	4 1/2	4
21	McIntyre	4	4 5/16	4 3/4
22	Stegeman	4	4 1/2	5 1/4
23	Reliance	2	5	5
24	Mais	4	4	5 1/4
25	Alco	4	5	6
26	Old Reliable	4	4 3/4	5 1/2
27	Durable Dayton	4	4 3/4	5 1/4
28	Pope-Hartford	4	4 1/2	5
29	Saurer	4	4.3	5.5
30	Stegeman	4	4 1/2	5 1/2
31	Sampson	4	5	5 1/2
32	Alco	4	5	6
33	Saurer	4	4.3	5.5



The heavy trucks weathered the mushy streets without great difficulty



Immense crowds witnessed the test of motor fire pumps at Milwaukee during the recent exhibition

## Fire Chiefs See Apparatus Tested

MILWAUKEE, WIS., Sept. 22—Motor-driven fire apparatus was the feature of the thirty-ninth annual convention of the International Association of Fire Engineers which closed here to-day. In fact, it was generally remarked that the parades and the exhibition at the Auditorium were as much a show of automobiles as of strictly fire-fighting rigs. Of the twenty exhibits of fire-fighting apparatus there was only one that was not gasoline propelled and only two pumping engines that were not operated by gasoline. One of those was a steamer which had been converted from a horse-drawn rig to a modern form by the substitution of a motor for the horses. In the pumping engine tests only gasoline-driven pumps took part.

Following is the official report of the tests:

Test No. 1. American-LaFrance Fire Engine Company, Elmira, N. Y. Double motor (six cylinder each) pumping car: horsepower of motor, 200; cylinders, 5 1-2-inch bore 6-inch

stroke; pump capacity, 300 to 800 gallons per minute. Discharged 262 gallons per minute through 1,000 feet of 2 1-2-inch hose and 1 1-4-inch ring nozzle; pump pressure, 270 pounds; suction pressure, 5 pounds; net pressure, 275 pounds; nozzle pressure, 56 pounds. Duration of test, 7 minutes.

Test No. 2. American-LaFrance Fire Engine Company, Elmira, N. Y. Same machine as in test No. 1. Discharged 322 gallons per minute through 1,000 feet of 2 1-2-inch hose and 1 1-2-inch smooth nozzle; pump pressure, 275 pounds; suction pressure, 5 pounds; net pressure, 280 pounds; nozzle pressure, 23 1-4 pounds. Duration of test, 15 minutes.

Test No. 3. American-LaFrance Fire Engine Company, Elmira, N. Y. Same machine as in tests Nos. 1 and 2. Discharged 645 gallons per minute through two 500-foot lengths of 2 1-2-inch hose, with one 1 1-8-inch smooth nozzle and one 1 1-4-inch ring nozzle; pump pressure, 225 pounds; suction pressure, 5 pounds;



Robinson pump and hose wagon, a compactly arranged combination



Ahrens-Fox pumping engine with pump located in front of radiator



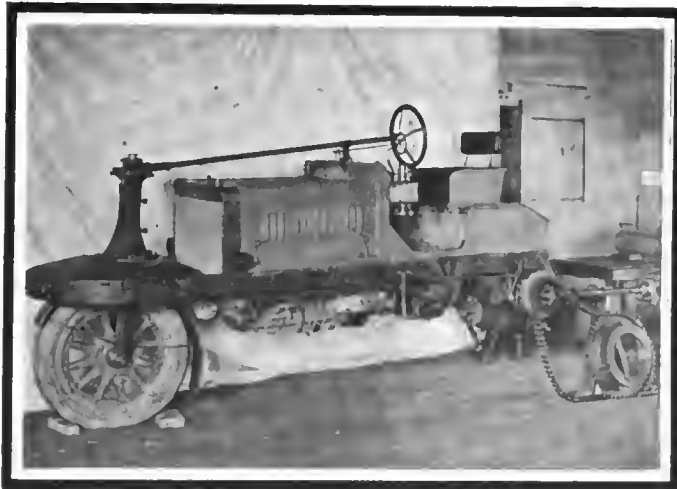

The Martin tractor, for drawing various forms of fire apparatus

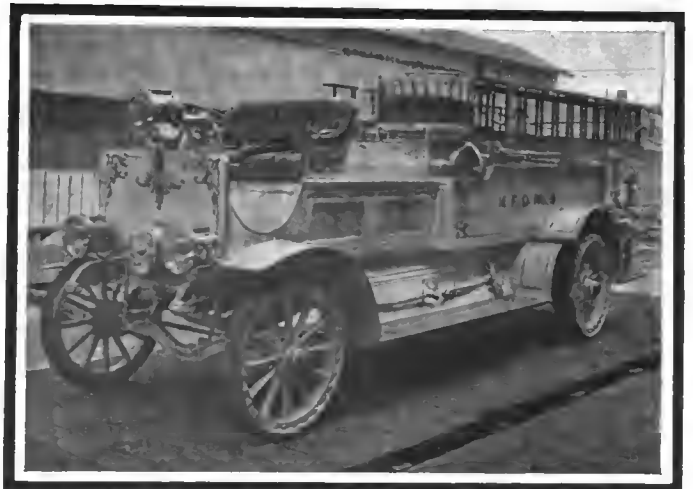

The Seagraves combination hose and chemical wagon

net pressure, 230 pounds; nozzle pressure, 79 pounds. Duration of test, 5 minutes.

Test No. 4. American-LaFrance Fire Engine Company, Elmira, N. Y. Same machine as in tests Nos. 1, 2 and 3. Discharged 825 gallons per minute through four 100-foot lines of 2 1-2-inch hose, siamesed into a deluge set with 1 3-4-inch nozzle; pump pressure, 100 pounds; suction pressure, 7 pounds; net pressure, 107 pounds; nozzle pressure, 82 1-2 pounds. Duration of test, 5 minutes.

Test No. 5. American-LaFrance Fire Engine Company, Elmira, N. Y. Four-cylinder motor-pumping car. Horsepower of motor, 70; cylinders, 5 1-2-inch bore, 6-inch stroke. Pump capacity, 450 to 500 gallons per minute. Discharged 264 gallons per minute through 1,000 feet of 2 1-2-inch hose and 1 1-8-inch smooth nozzle; pump pressure, 216 pounds; suction pressure, 5 pounds; net pressure, 221 pounds; nozzle pressure, 49 1-2 pounds. Duration of test, 5 minutes.

Test No. 6. Same machine as test No. 5. Discharged 444 gallons per minute through two 500-foot lines of 2 1-2-inch hose, each with 7-8-inch smooth nozzle; pump pressure, 166 pounds; suction pressure, 6 pounds; net pressure, 172 pounds; nozzle pressure, 96 pounds. Duration of test, 5 minutes.

Test No. 7. American-LaFrance Fire Engine Company, Elmira, N. Y. Six-cylinder motor pumping car. Horsepower of motor, 100; cylinders, 5 1-2-inch bore and 6-inch stroke. Capacity, 600 to 700 gallons. Discharged 249 gallons per minute through 950 foot of 2 1-2-inch hose and 1 1-8-inch smooth nozzle; pump pressure 188 pounds; suction pressure, 3 pounds; net pressure 191 pounds; nozzle pressure, 44 1-2 pounds. Five minutes.

Test No. 8. Same car as test No. 7. Discharged 425 gallons per minute through two 500-foot lines of 2 1-2-inch hose and 7-8-inch smooth nozzle; pump pressure, 153 pounds; suction pressure, 3 pounds; net pressure, 156 pounds; nozzle pressure, 89 pounds. Duration of test, 5 minutes.

Test No. 9. The Ahrens-Fox Fire Engine Company, Cincin-

nati, Ohio. Six-cylinder motor pumping car. Horsepower, 72; pump capacity, 400 to 500 gallons per minute. Discharged 244 gallons per minute through 1,000 feet of 2 1-2-inch hose and 1 1-8-inch smooth nozzle; pump pressure, 185 pounds; suction pressure, 5 pounds; net pressure, 190 pounds; nozzle pressure, 42 1-2 pounds. Duration of test, 15 minutes.

Test No. 10. Same machine as test No. 9. Discharged 340 gallons per minute through two 500-foot lines of 2 1-2-inch hose, with 7-8-inch smooth nozzles; pump pressure, 93 pounds; suction pressure, 4 pounds; net pressure, 97 pounds; nozzle pressure, 56 1-2 pounds. Duration of test, 5 minutes.

Test No. 11. Webb Motor Fire Apparatus Company, St. Louis, Mo. Six-cylinder motor pumping car. Horsepower, 80; pump capacity, 600 gallons per minute. Discharged 246 gallons per minute through 1,000 feet of 2 1-2-inch hose and 1 1-8-inch smooth nozzle; pump pressure, 170 pounds; suction pressure, 3 pounds; net pressure, 173 pounds; nozzle pressure, 43 pounds. Duration of test, 3 minutes. Test of this car discontinued on account of lubricating device not working satisfactorily.

Test No. 12. Same company. Another car, six-cylinder, horsepower, 80. Pump capacity, 600 gallons per minute. Discharged 224 gallons per minute through 1,000 feet of 2 1-2-inch hose and 1 1-8-inch smooth nozzle; pump pressure, 157 pounds; suction pressure, 4 pounds; net pressure, 161 pounds; nozzle pressure, 36 pounds. Duration of test, 5 minutes.

Test No. 13. Same car as test No. 12. Discharged 361 gallons per minute through two 500-foot lines of 2 1-2-inch hose and 7-8-inch nozzle; pump pressure, 113 pounds; suction pressure, 6 pounds; net pressure, 119 pounds; nozzle pressure, 63 1-2 pounds. Duration of test, 7 minutes.

Test No. 14. Same car as tests Nos. 12 and 13. Discharged 589 gallons per minute through two 100-foot lines of 2 1-2-inch hose, siamesed into a deluge set with 1 3-4-inch nozzle; pump pressure, 68 pounds; suction pressure, 9 pounds; net pressure, 77 pounds; nozzle pressure, 42 pounds. Duration of test, 5 minutes.



The Seagraves aerial ladder, with four-wheel drive and steer, one of the interesting exhibits at the Milwaukee show

# In the Making of Poppet Valves

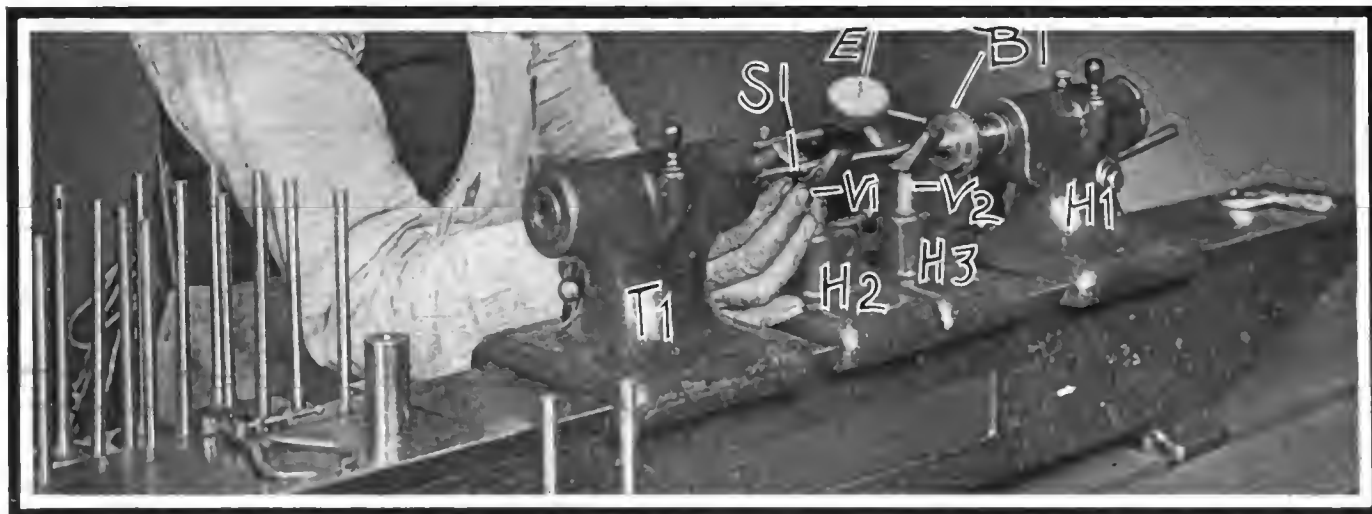

Fig. 1—Method of calibrating valves in order to determine the truth of the seats in relation to the stems



Fig. 2—Components of the built-up valve, showing the various stages of development of valve stems and mushroom welded to it

It is proposed here to show the various stages of manufacture of the poppet valve from the rough material to the finished product. It may surprise some to know that eleven operations are necessary to make a valve, without counting such operations as calibrating and transporting from one machine to the other.

Much has been written of late of different types of valves other than the poppet, which may have created in some people's minds the impression that the death-knell of the poppet valve has been sounded. There does not seem to be any abatement on the part of manufacturers in the use of this type of valve, and one has but to think of the marvelous results that have been achieved with it in the last few years to make it apparent to the veriest tyro that if anything is to come along to supplant

it the innovation will have to possess merits out of the ordinary.

A few years ago, when makers were still groping around in the dark without any fixed purpose, except perhaps to make the cars that were turned out run passably well, it was more or less a case of follow-my-leader, and the errors that were made by one manufacturer were copied by the plagiarists of that particular car. It is still within the memory of many that certain cars were taken as prototypes and were copied, lock, stock and barrel. Since the science of building automobiles has developed and the difficulty of making cars run has been overcome, the attention of designers was directed to silencing the road locomotive.

In the earlier days not a little noise emanated from the valve mechanism and this was one of the first things to be attacked in a serious manner. With the poppet valve of the present day, properly made and its operating mechanism carefully designed, there is no reason why noise should be in evidence. The little extra touches of finesse that are added to racing cars deprives them of silently operating valves, as the cams employed for such machines have a different contour from valves used on touring cars. The reason for this is that the valves that control the flow of the gases are in a measure responsible for the amount of gas that is taken into the cylinders; a slow-closing valve which may be quiet will not give the snap to the machine that is the desired quality of a racer. The weight of the reciprocating parts is another point to be considered, but this will be dealt with later. Before dealing with the operation of the valves it will be as well to show how the part is manufactured, taking the various operations seriatim. The finished valve does not look so formidable that it should be requisite to spend

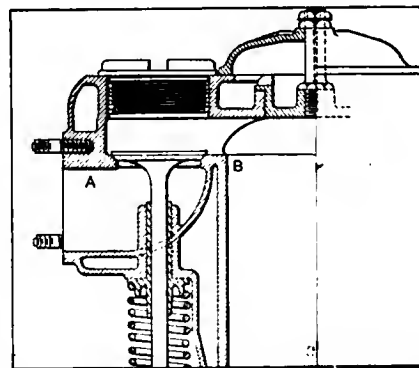

Fig. 3—Section through the cylinder of a motor in which the water-cooling area is bad

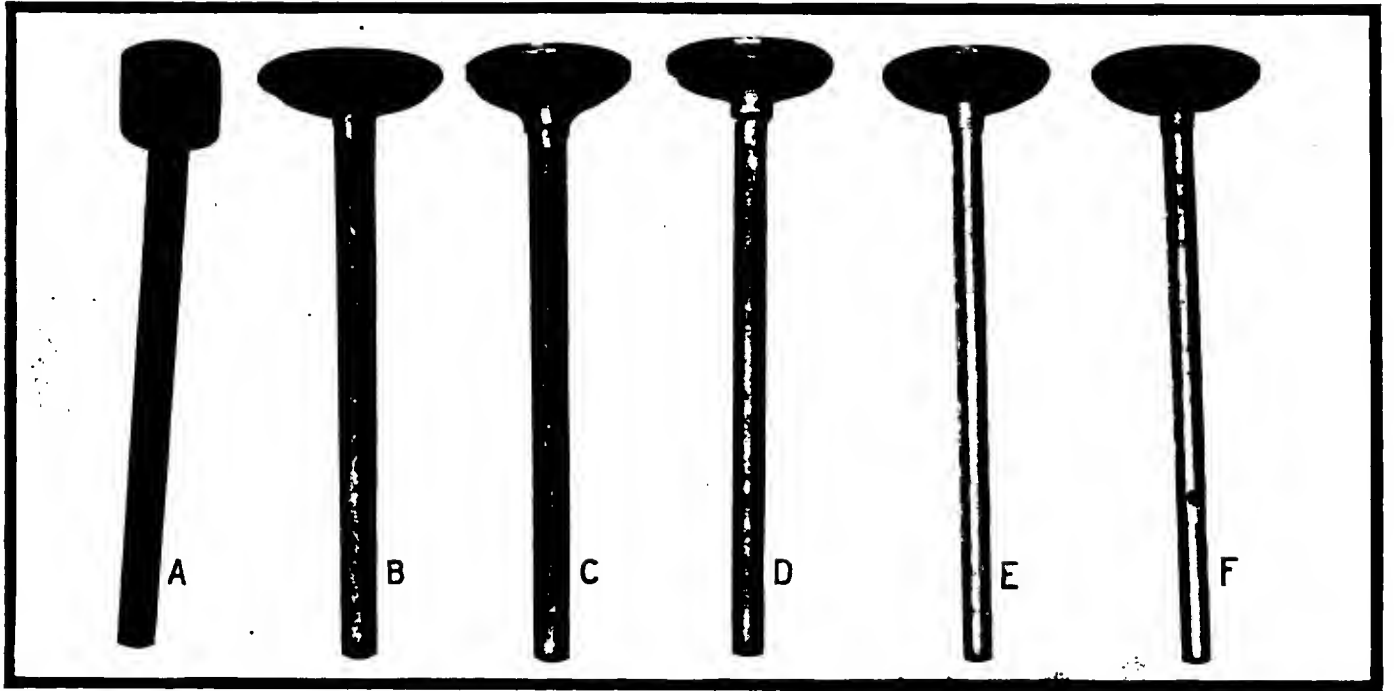

Fig. 4—Showing the appearance of a valve at its different stages of manufacture from the solid rod

much work upon it, but it is not always the part that looks simple that is the easiest to make.

There are two types of poppet valve in vogue at present in gasoline motors. The difference lies in the seat of the valve. The majority of motors have valves with cone seats, but some prefer the flat-seat type. The advantage claimed for the cone type is that it is less liable to pit at the seats, owing to the angularity of the seat being better swept by the flow of the exhaust gases. In case a valve cannot seat there will be a gap on one side and not on the other.

Referring to the question of gap, this may be caused by the deformation of the valve itself, due to improper water-cooling area around the seat. Unless this area is uniform the seat will heat at one point more than another and prevent the valve from properly closing. In the case of the intake valve this may cause a blow-back in the carbureter, but as the heat of the burnt gases passing out of the exhaust passageway materially increases the temperature of the ports the trouble above-mentioned is more likely to obtain in the case of the exhaust valve than with the intake. The consequence would be that owing to the improper seating of the exhaust valve part of the compression would leak past and the motor would not be able to develop its full power. A comparison of two motors in which the difference in the water cooling around the valve is shown in Figs. 3 and 5. In Fig. 3 is shown a solid wall around the valve seat at the point A, while B is bathed by the cooling water.

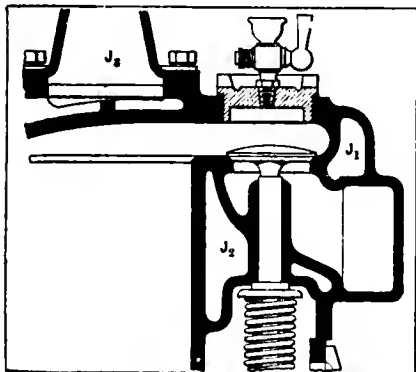

Fig. 5—Section through a valve pocket showing how the entire seat is properly cooled

Fig. 5 shows a uniformity at J1 and J2, which will keep the temperature balanced.

Besides the methods about to be illustrated there are others that apparently give good results; but those shown being the more commonly employed, it is proposed only to deal with them. In order to differentiate between the two methods of manufac-

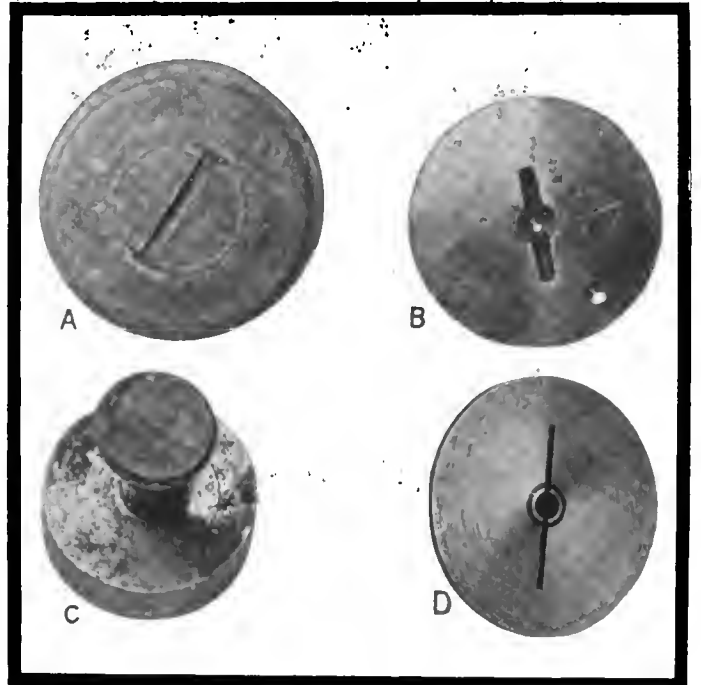

Fig. 6—A and B show the rough and finished valve stamped from one piece; C shows the metal before stamping, and D the finished valve

ture it may be as well at the outset to designate them as the "stamping" and "building up" processes. Dealing with the stamping process, if reference be made to Fig. 4, the different forms that the valve takes during the various stages of manufacture will be seen. A shows the first stage in which a piece of rod is drawn on the hammer in order to form the stem. This operation is very simple and does not need any particular care, with the exception that the metal should not be overheated. The same applies to the next process, when the part as shown at A is heated before being placed in the die, shown in Fig. 9. In this illustration the head of the red-hot valve (V1) may be seen in the die (D1). The weight is allowed to drop twice, the upper half of the die (D2) battering the metal and forming the mushroom. The appearance of the valve as it leaves the

steam hammer is shown at B, in Fig. 4, and in order to save one operation, viz., that of slotting the head of the valve to receive a screwdriver to facilitate grinding, the upper part of the die has a protrusion which slots the head of the valve in a manner similar to that shown at A in Fig. 6. The head of the valve at B in this illustration shows the manner in which it is centered for the various machines into which it has to be inserted, as well as a small hole for the pointer which holds it in position and prevents it from slipping while being turned.

The head is then ground and the seat cut rough on the lathe, the correct contour being given to the fillet, as shown at C in Fig. 4. The next operation consists in placing the valve in the lathe in the manner shown in Fig. 8 in order to turn up the stem to the required thickness. The valve is centered in the chuck (C) and the tool (T) held in the tool-holder (H). When the valve leaves the lathe it is practically in the rough—that is to say, unfinished. It is possible by using other cutters to finish the valve so that it would be ready to place in a motor, but the present-day methods of grinding are preferred by most manufacturers.

The valves are next transported to a machine where boys drill three holes in the stem of each valve preparatory to the

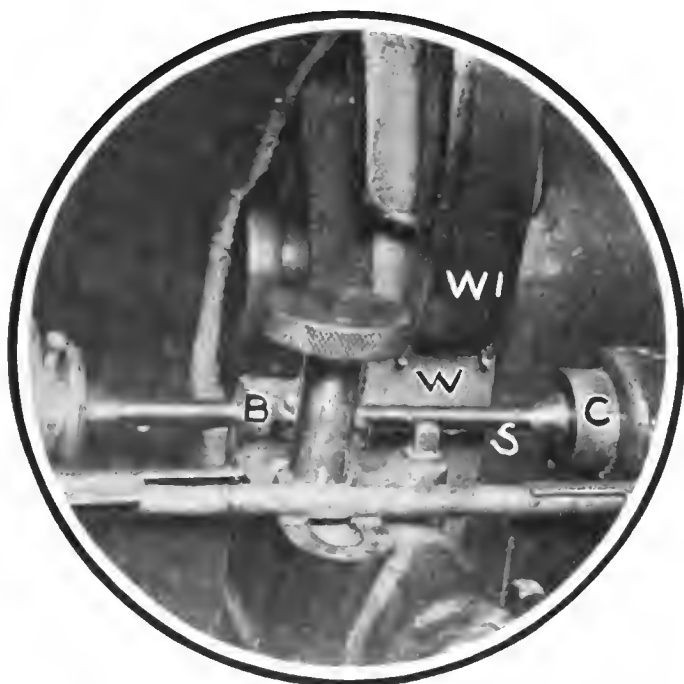

Fig. 7—Showing the grinding operation for the stems of valves

operation of cutting the slots for the cotter pins. The latter operation is shown in Fig. 11. The valve (V) is placed in the receptacle in the plate (P), which has a slot cut therein at S. The chuck (D) of the hammer is furnished with a slotting tool (C) held in position by the setscrew (SI). As the weight falls the slotting tool cuts the metal between the holes that have been previously drilled, but the blow is apt to slightly bend the stem of the valve.

It is a simple matter to rectify this and the operation of straightening the stem is shown in Fig. 10. The operator is furnished with a tool that has two centers into which the valve is placed and sufficient tightness is furnished by the milled nut (N) to hold the valve in position. The valve lying alongside the machine shows the amount of disalignment that has to be corrected. The operator spins the valve and with the aid of a piece of chalk (C), held in his left hand, the high spot can be located. Usually a single blow with the hammer (H) at this point will be sufficient to correct this, but it may require several blows before the valve is again true. The operation does not call for a great amount of skill, consequently un-



Fig. 8—Method of rough turning the valve after having both ends centered

skilled labor is employed for this work with satisfactory results.

The next operation, that of grinding the valve stem (Fig. 7), may be performed in the same machine that is used for grinding the seat, but at the Maxwell plant, where the illustrations of the stamping process were made, the operation is carried out in two stages. The valve head is placed in the lathe center (C) and a lathe carrier causes the valve to rotate. In order to avoid any whip in the spindle when the pressure of the grinding wheel (W) is brought to bear upon it a split block (B) forms a rest for the spindle. The valve stem rotates in a clockwise direction, while the grinding wheel (W) revolves in an anti-clockwise sense, a steady stream of water being meanwhile fed through the pipe (WI) to the part being ground. The valve, after the stem has been ground, is shown at E, in Fig. 4. The last operation in the manufacture is illustrated in Fig. 12, in which the valve (St) is centered in the head of

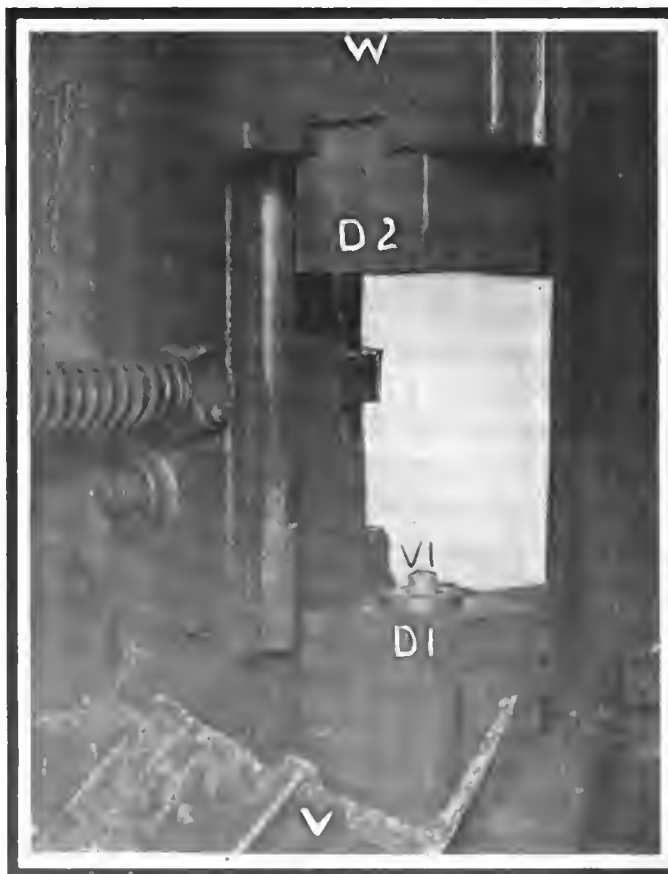

Fig. 9—Showing the hammer with the valve in position ready to be stamped

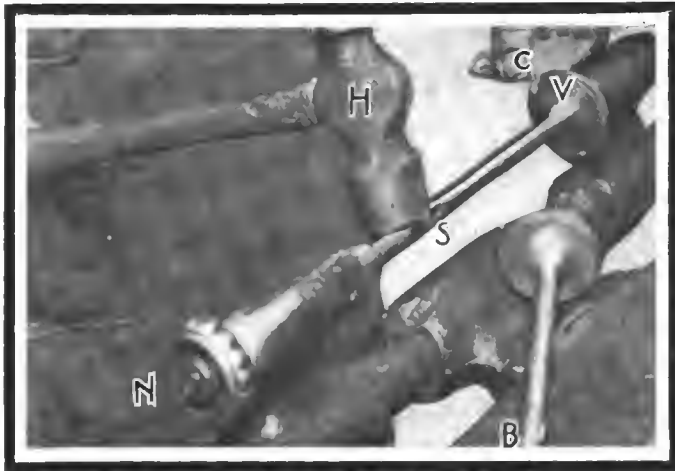

Fig. 10—Truing up the stem of a valve after cotter pin slot is stamped

the lathe (C) and attached to the chuck (C1). The valve is caused to rotate in the opposite direction to the grinding wheel (W) and water is fed, as in the stem grinding operation, through the pipe (W1). The finished valve is shown at F, in Fig. 4.

The method of building up the valve from two parts instead of stamping it from the solid, as already described, may be seen very clearly by referring to Fig. 2. In the case of the stamped valve it is of a necessity that the entire valve be of the same material, whereas in the built-up valve a different material may be used for the seat to the stem. In the illustration referred to the process is as follows: The stick of .15 carbon steel G is compressed at the top extremity so as to present a form similar to H, in Fig. 2. A disc I, 11-16 of an inch thick and 1.3-4 inches in diameter, is cut from .05 nickel steel stock, drilled with a 1-2-inch hole and placed over the

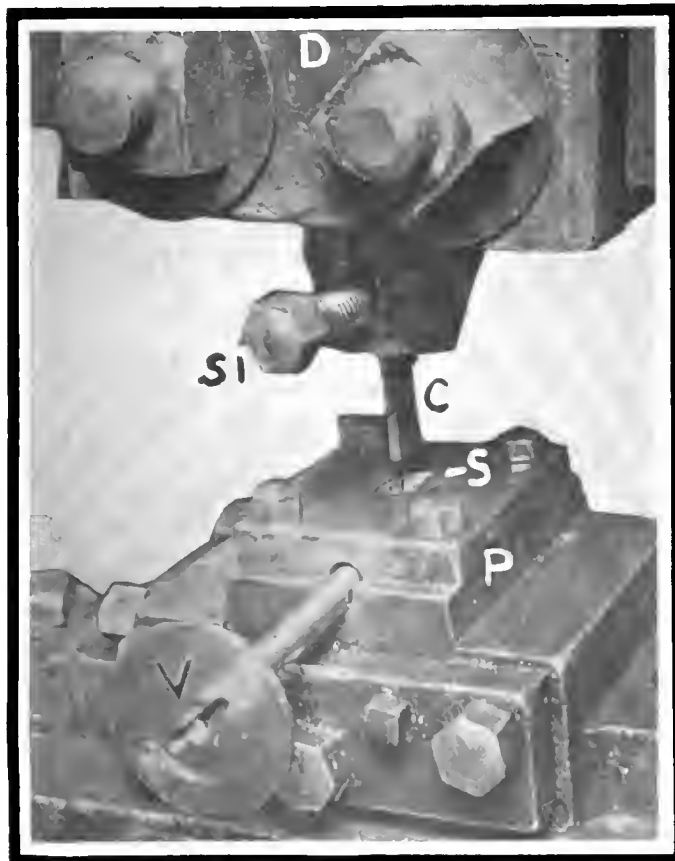

Fig. 11—Slotting machine with which the slots in the valve stem are cut

stem in the manner shown at C, in Fig. 6. The assembly is then heated and placed in a die in a manner similar to that shown in Fig. 9, and the two parts are thus welded together. The form that they take is shown at J, in Fig. 2. The thickness of the head after welding is reduced to 7-16 of an inch, and the width increased to 2.3-4 inches. The finished valve is shown at K, in which the thickness of the head, after turning, is 9-32 of an inch and the diameter of the upper face 2.15-1.6 inches. D, in Fig. 6, shows the head of the valve after being turned and slotted. The illustrations of the assembly process were taken at the Mercer plant, and it will be noticed in K, in Fig. 2, that the base of the stem is slightly smaller in diameter in order to accommodate a split ring for holding the valve spring in place.

Fig. 1 shows a process sometimes resorted to in order to determine whether the stem and seat are absolutely concentric. The valve is chucked and rests lightly on the holders (H2 and H3), and by rotating the valve by hand, it is possible to read on the dial of the instrument (E1) the most minute fault in the manufacture. A valve may seat quite well on one of the valve seats, but as all valves at the present day are being made interchangeable, it is necessary that all shall be alike.

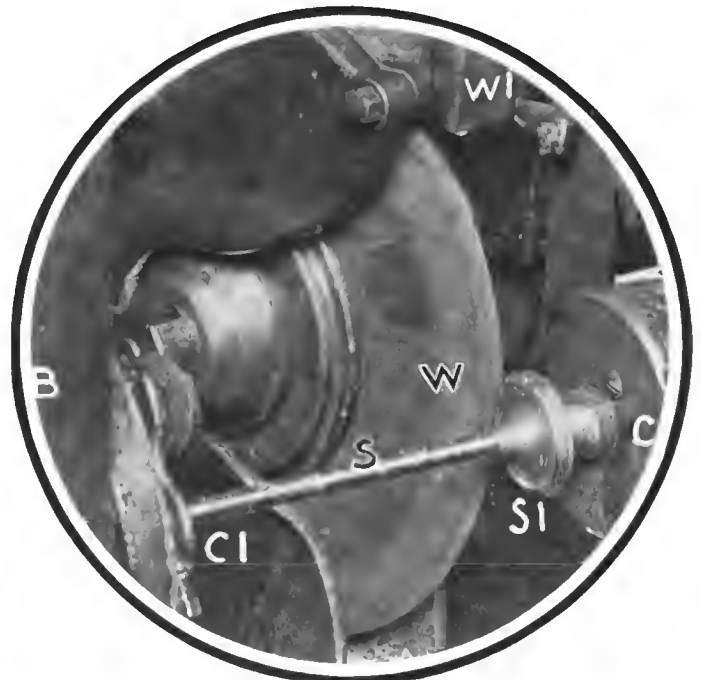

Fig. 12—Grinding the seats of valves, thereby giving a true surface

### Steel Should Be Tested for Nitrogen

Steel of unknown origin should be tested for nitrogen rather than for phosphorus. The popularly accepted idea that phosphorus and an excess of sulphur cause brittleness—an idea which finds expression in most specifications for steel materials—should be corrected as promptly as possible by placing under ban nitrogen first of all, as this substance may be found in all kinds of steel while phosphorus and sulphur are unlikely to exceed 0.06 per cent. in either acid or basic open-hearth steel. That nitrogen is the impurity to which the comparative brittleness of Bessemer steel is mainly due was first pointed out by Braune, a Swedish chemist living in Paris, but while it is always present in unrefined Bessemer steel it may be found in open-hearth steel as well. Nitrogen in excess of 0.06 per cent. should never be admitted for boiler plate, for example. (The boiler explosions in the French navy have made this subject one of national importance in France.) The author has repeatedly argued the question of the cause of brittleness in steel before the British Iron and Steel Institute since 1885.—C. E. Stromeyer in *La Technique Automobile et Aérienne*, February and March.



# Stresses and Strains in Tires

## Part III.

Translation of an article by Henri Petit from *La Technique Automobil et Aérienne*

THIS high coefficient of security shows that a tire cannot burst under normal conditions through an additional excess of pressure.

The tension of the canvas being always proportional to the internal pressure it can be seen even in the most unfavorable case, viz.: that of a 135 m.m. tire that it would be necessary to raise the internal pressure to 56 kilos to arrive at a tearing point of the canvas. In practice the tire will probably burst before this limit is reached, owing largely to the inevitable imperfections of manufacture due to the unequal tension of the canvas.

But the fact remains, however, that practical tests that have been carried out by the simple means of increasing the internal pressure in order to burst a tire have been without result; in nearly all cases the rims become deformed, allowing the beads of the tire to fly out before the tire shows signs of weakness.

The fears possessed by certain chauffeurs of having their tires burst in the sun are mere myths, in most cases. The amplification "most cases" is used because it is evident that if a tire is old and the canvas has been subjected to the action of the humidity to the point of becoming rotten (which is a state that exists more often than one would think, for although the tire looks to be in good condition) a burst can very easily take place.

### Action of the Temperature

It is interesting to note the influence of the temperature on the internal pressure in tires. Suppose a tire to be inflated at 0° to a regular pressure of 10 kilos. During the course of the day, under the simultaneous action of the sun and especially the speed and weight of the car, the imprisoned air can attain a temperature of 80° Centigrade, consequently producing an increase of pressure.

The pressure  $p$  attained at this moment will equal:

$$p = p^{\circ} (1 + \alpha t)$$

that is to say,

$$p = p^{\circ} \left[ 1 + \frac{80}{273} \right] \\ = p^{\circ} \times 1.3 \text{ about.}$$

The pressure will only rise in the third of the primary value. The proportional increase of the tension on the canvas for a tire in good condition is more or less a negligible quantity.

Further, when one talks of the causes of deterioration of tires it will be seen that the action of the heat on the rubber is more important than on the internal pressure.

### Action of Weight on Tension of Canvas

All that has previously been stated refers to a tire simply inflated and not carrying any weight.

There is nothing to be modified in the conclusions drawn if one only passes to a practical case where the tire rests upon the ground and carries a weight  $P$ . (It will be remembered that we are only interested at the moment in static efforts—that is to say, the case when the tire is stationary.)

Under the influence of the charge the tire will flatten out until the force exerted by the internal pressure on the surface of contact equilibrates the weight supported.

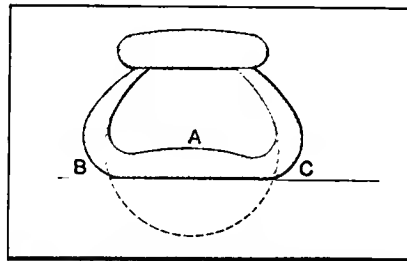

Fig. 4—Showing change in form of meridian section of insufficiently inflated tire

Allowing for the stiffness of the canvas it can be seen that we will have the equation

$$ps = P$$

calling  $s$  the surface of contact of the tread with the ground and measured in square centimeters.

This contact area is not in the form of a well-defined geometrical form. It can be likened to an ellipse, the greater axis of which lies in the lateral plane of the wheel. This ellipse will be proportionally lengthened according to the narrowness of the tire and the increase in diameter of the wheel.

It can be seen that the work necessary for the propulsion of the car is dependent on the form of this surface, and is greater according to the relation of the large and smaller axis being smaller.

The flattening of the tire produces a depression in the interior of the casing and the volume thereof diminishes slightly due to this flattening. The increase in pressure is quite insignificant and need not be considered. The point which must be borne in mind, however, is the change in the form of the meridian section of the tire at the point of contact with the ground. Fig. 4 shows in an exaggerated form what takes place.

If the tire were very narrow or, on the other hand, formed of a single layer of canvas this deformation would not be of great importance. But as the various layers of canvas present a considerable thickness, it follows that to pass from the normal form to the form represented in Fig. 4 the layers of canvas will slide on one another. This displacement is possible owing to the layer of rubber compound interposed between each layer; the rubber stretches at the points extended and contracts at the others, permitting a small relative displacement.

It is clear that this sliding should be as small as possible; the tensions that are developed between the layers of canvas and their coating of rubber develop, as a matter of fact, values proportionately greater as the displacement increases, tensions which could in time cause the rubber to become detached from the canvas.

On the other hand, on account of the hysteresis that accompanies all physical phenomena, in the present case the deformations of the rubber, during the movements of the revolutions of the wheel successive deformations of the diverse sections are accompanied with a considerable production of heat.

In a large measure it is due to this that a tire that is insufficiently inflated (or overcharged, which comes to the same thing in the case under notice) heats more than the same tire submitted to the same charge, but inflated to a greater degree. Another cause of heating lies in the friction of the tire with the ground; this will be dealt with later.

### Method of Attachment

The tire is held in position in the rim by the pressure of the air on the beads.

It is interesting to form an idea of the greatness of the force that holds the tire in position. The tire in the vicinity of the sides of the bead is submitted to the action of two forces: the one  $\Phi$  (superficial tension) tends to draw the bead outward, the other  $F$  (arising from the internal pressure) has on the contrary action of forcing the bead into the base of the rim (Fig. 5).

On account of the form of this latter, it is possible for the bead to turn around the point A (allowing for the resistance of the canvas). Then the force  $\Phi$  is applied at the middle of the thickness  $e$  of the tire at this point. Its moment in relation to the fixed point A is equivalent to

$$\frac{\Phi \times e}{2}$$

The force  $F$  is applied at the middle of the interior width of the bead. It is normally at the surface. Its moment in relation to A is

$$\frac{Fl}{2}$$

In order that the bead should be maintained in position, one must have

$$Fl > \Phi e$$

For the unity of the length of the tire the force  $F$  is equal to:

$$p \times l$$

The force  $\Phi$  is the maximum meridian tension of the tire. It is expressed by

$$T_M = \frac{Rr}{R-r} p$$

From which

$$p^2 > p e \frac{Rr}{R-r}$$

The resultant couple, which we will call the couple of security, will be equal to the difference of the components

$$C = \frac{p}{2} \left[ p^2 - e \frac{Rr}{R-r} \right]$$

It should be positive and have as large a value as possible.

Let us calculate this value for current dimensions of tires (90, 120, 135).

The value of  $C$  can be written

$$C = \frac{p}{2} \left[ p^2 - e \frac{R}{r} \right]$$

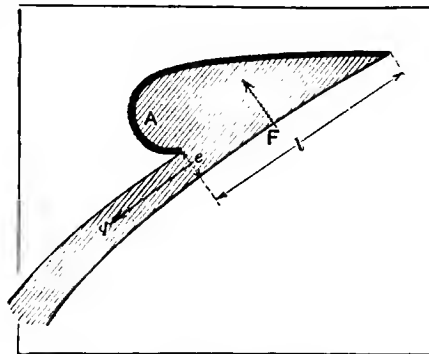

Fig. 5—Showing forces acting on bead of tire

From the foregoing it becomes at once apparent that  $C$  will be proportionately smaller as  $\frac{R}{r}$  decreases in size.

The values of  $\frac{R}{r}$  are given in the table earlier in the article.

The minimum values are:

- 7 for tires 700 X 90
- 6 for tires 820 X 120
- 5.5 for tires 895 X 135

It will be remembered that for each section  $\frac{R}{r}$  is proportionately smaller as the size of the wheel is smaller.

The corresponding value of  $\frac{R}{r}$  are respectively

- 3.5
- 6.3
- 8.5

The thickness  $e$  is approximately equal to 1 millimeter per layer of canvas as:

- 6 millimeters for a tire of 90 m.m. section.
- 8 " " " 120 " "
- 9 " " " 135 " "

But for a 90 m.m. section tire the width of the bead is about 23 millimeters.

From which for  $C$

$$C = \frac{p}{2} \left[ 2.3^2 - 0.6 \times 3.5 \right] = p \times 1.6$$

8 kilo-centimeter per centimeter.

It is necessary, therefore, that the width of the beads increase with the tire width.

To obtain a like value for  $C$  with a tire 895 X 135 (taking into consideration the internal pressures) it is necessary to make the beads 33 millimeters wide.

These figures, though seeming to be void of interest in themselves, nevertheless should be borne in mind.

## Harking Back a Decade

THE *Motor Review* of September 26, 1901, contained the following items indicating the growth of the new automobile industry:

Announcement is made that an American factory for the Charron was to be installed with a capacity for the 1902 season of 100 cars a month.

The Washington Auto-Vehicle Company was incorporated for \$1,000,000 to manufacture pleasure cars and parts, and it was announced that in the future the company would take up the manufacture of army automobiles, fire apparatus and cars for various kinds of municipal and government work.

It is noted that Ray MacDonald and Howard Freeman, former bicycle stars, had taken jobs as chauffeurs with the Automobile Company of America.

A. J. Eddy, of Chicago, who completed a trip from his home to Boston and New York in a single-cylinder Winton, two weeks before the publication date, expressed himself as being confident that American automobiles were better for cross-country touring than foreign machines.

Exports of automobiles and parts from the United States for the week ending September 18, 1901, amounted to \$24,000. Dur-

ing July, 1901, the automobile exports were valued at \$72,000.

Announcement was made that W. D. Gash, of the Waltham Manufacturing Company, had been made sales manager for the Searchmont Motor Company.

W. B. Felker, of Denver, recounted his experience in climbing Pike's Peak, using the abandoned wagon road up that mountain. The round trip required over fifteen hours, using his steam Locomobile. At that time the climb represented a new altitude record for the automobile.

Great preparations were being made for the Fort Erie race meeting, which project had been revived after being called off on account of McKinley's assassination. The Automobile Club of Buffalo hung up silver cups for the winners in the various classes, for which twenty-one entries were made.

The Consumers' New York Rubber Tire Company, incorporated by W. H. Seaich, John W. Horner, Alfred D. Moulton, Hooper C. Barrett and Andrew C. Farnsworth, was announced.

The leading patent outlined in that week's issue was No. 682,194, granted to Henry K. Hess, of Philadelphia, on a steam automobile using charcoal or other carboniferous fuel in solid form instead of liquid hydrocarbon.

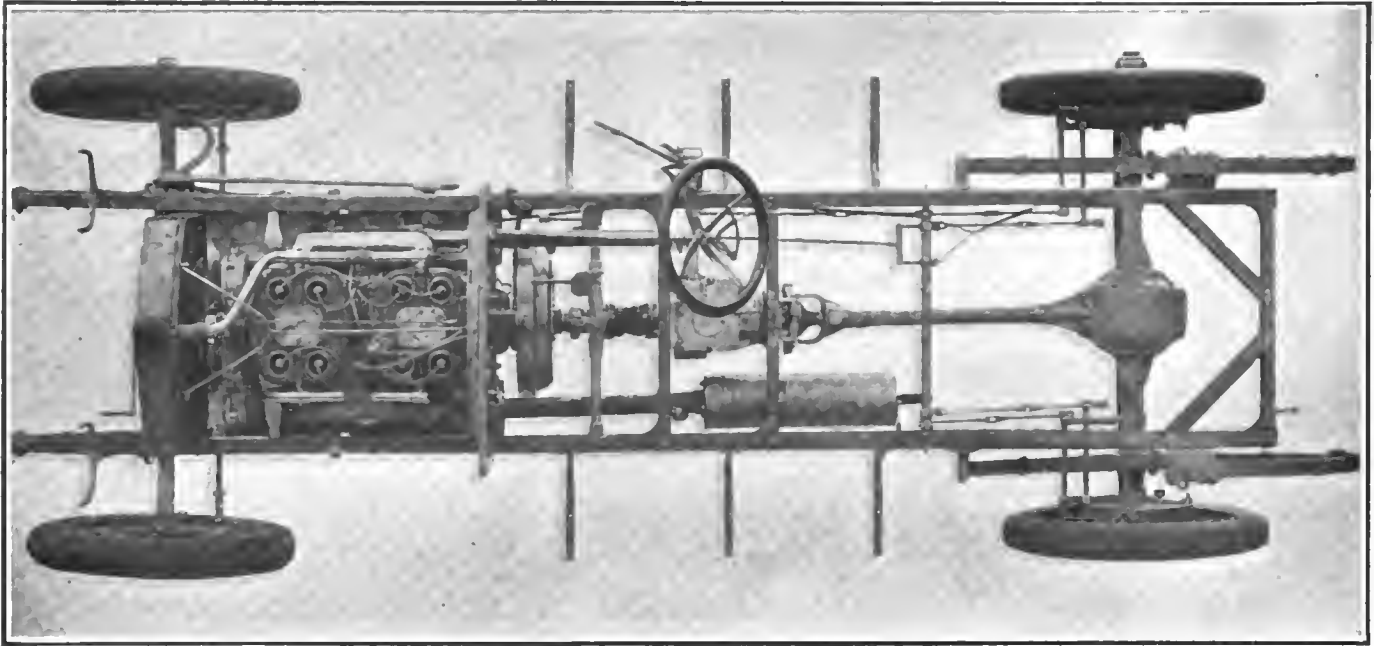

Fig. 1—Looking down on the National chassis, showing power plant, suspension and assembly of units

## Details of National Construction

NO marked changes characterize the new season's models of the National Motor Vehicle Company, of Indianapolis, Ind. The new models will be known as the National "40," Series S, and a numerical suffix will be used to designate the particular style of body. The changes that will be made will be along the line of refinements, in view of a year's experience, both on the road and in the racing field. Improvements in manufacturing operations designed to eliminate wear and noise have been carefully studied and nothing has been left undone to render the car satisfactory in every way.

The general appearance of the chassis may be seen from the plan view shown in Fig. 1, which discloses a four-cylinder motor attached to the main frame, cone clutch, three-speed transmission, and live rear axle drive. The method of operating the brakes is also shown in this illustration.

The motor has four cylinders, cast in pairs, and thoroughly

annealed, the bore being 5 inches and the piston travel  $5\frac{11}{16}$  inches. Fig. 5 shows a front transverse section through one-half of a cylinder together with the base chamber. The cylinders are cast with T-heads and the intake and exhaust valves, which are made of nickel steel, are placed on opposite sides. The valve V has a cone seat S<sub>1</sub> and reciprocates in a bushing B which is inserted into the cylinder casting. The cam operation may be seen by referring to the cam C<sub>1</sub>, upon which a roller R rides. The push-rod P<sub>1</sub> is fitted at its upper extremity with adjusting nuts N, and the roller R is held in constant contact with the cam C<sub>1</sub> by means of a spring S<sub>2</sub>.

The method of attaching the exhaust manifold E and the water manifold W is unique. The yoke Y has a forked end F and a single arm A so that when the nut N<sub>1</sub> is tightened upon the stud S both manifolds are maintained firmly attached to the cylinders, thereby eliminating a large number of connections.

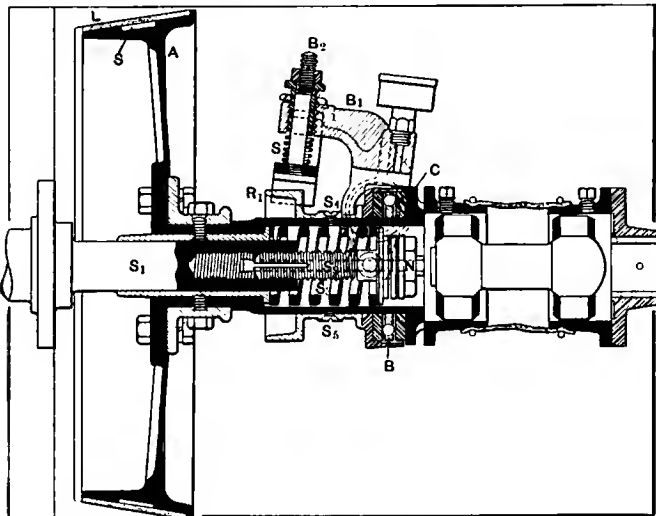

Fig. 2—Detailed view of the National cone-type clutch and universal joint

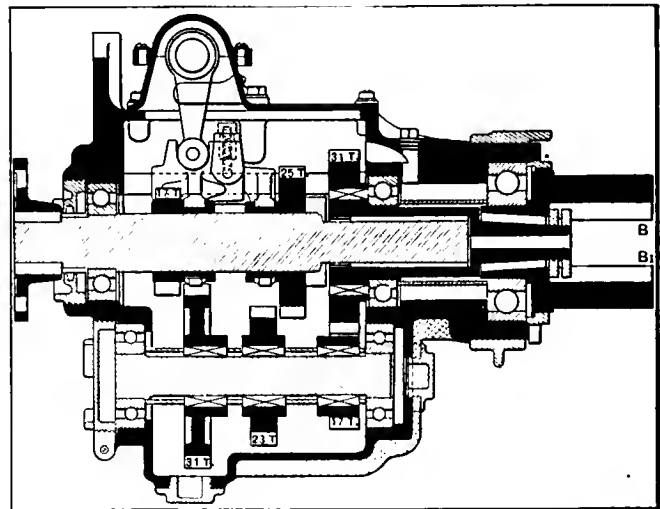

Fig. 3—Horizontal section through the three-speed and reverse selective transmission

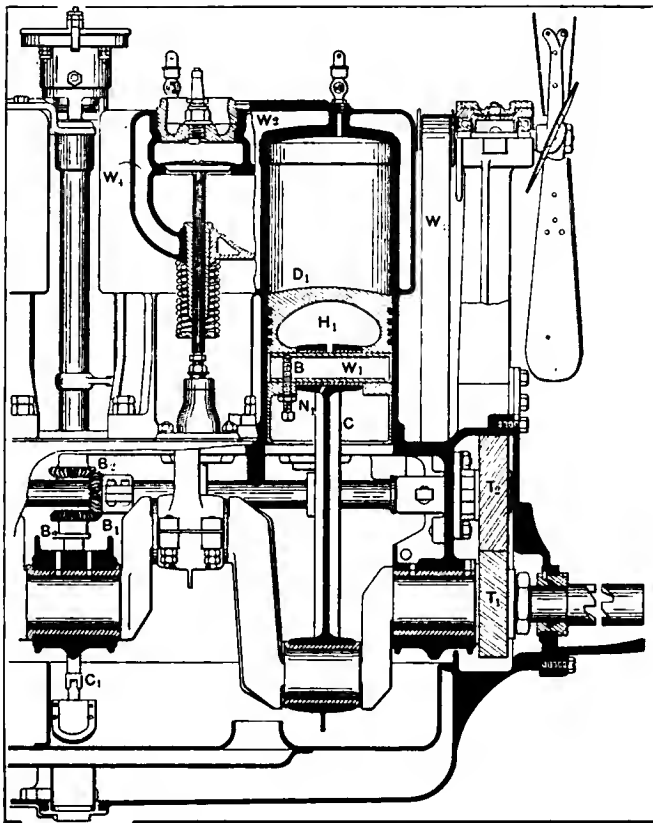

Fig. 4—Plan section of National motor, showing oiling, ignition and cooling systems

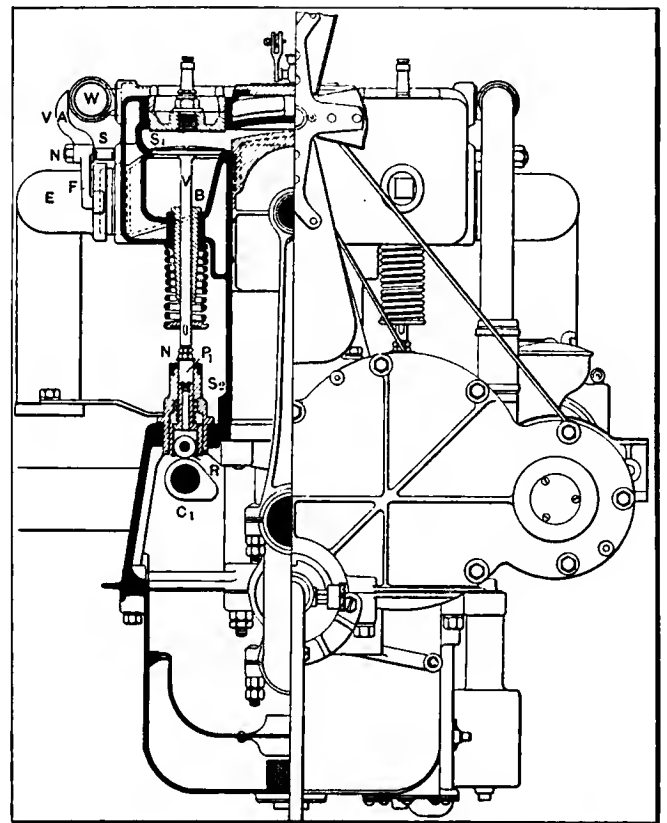

Fig. 5—Front transverse section through an engine cylinder and part of the base-chamber

The plan section of the motor, Fig. 4, discloses the method of operating the oil pump and distributor by means of bevel gearing B1, B2 and B3. The pistons have a slight dished top D1 and the wrist pins W1 are hollow. The method of mounting the piston wrist pin and connecting rod is shown in this illustration, and it will be seen that the wrist pin and piston are united by means of the bolt B and locked in position by the nut N1. This allows the connecting rod C to oscillate upon the wrist pin W1 and the small end of the connecting rod has a hole drilled above in order to permit the lubricant to enter. The oil pump being driven by the shaft attached to the bevel gear G2 can be removed from the lower half of the base chamber without disturbing the position of

the above-mentioned gear wheel, as there is a tongue joint C1 interposed between the pump shaft and the operating shaft. The water jacketing of the motor is shown at W2, W3 and W4, which illustrates the manner in which the cylinder is cooled to the point where the heated gases obtain.

The timing gears T1 and T2 are skew-cut, a practice which has been found to eliminate a considerable amount of noise from these parts. The crankshaft is mounted on three main bearings, made of Parsons white bronze.

Fig. 6 shows the exterior view of the motor. From this it will be seen that the support S1 by means of which the motor is attached to the frame at its forward extremity is bolted to the upper half of the aluminum base chamber instead

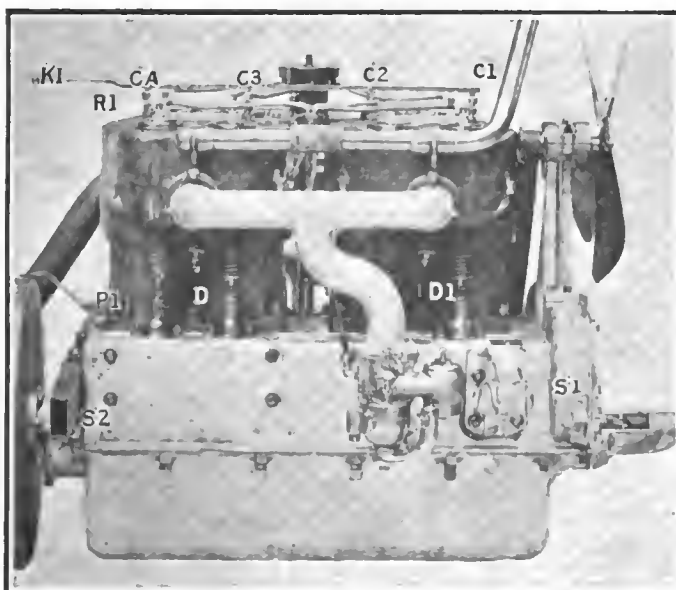

Fig. 6—Intake side of motor, showing substantial supporting members, carbureter and cocks to drain water from jackets

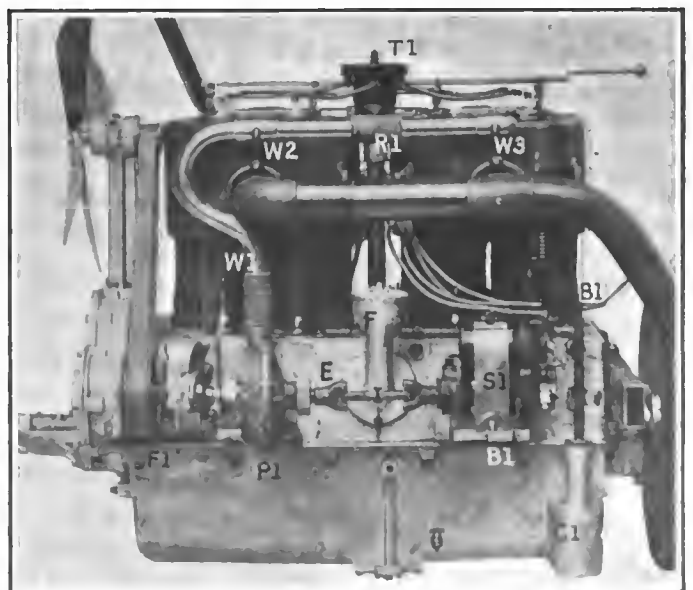

Fig. 7—View of the exhaust side of the motor, showing magneto, water pump, oil filler hole and cork-float indicator housing

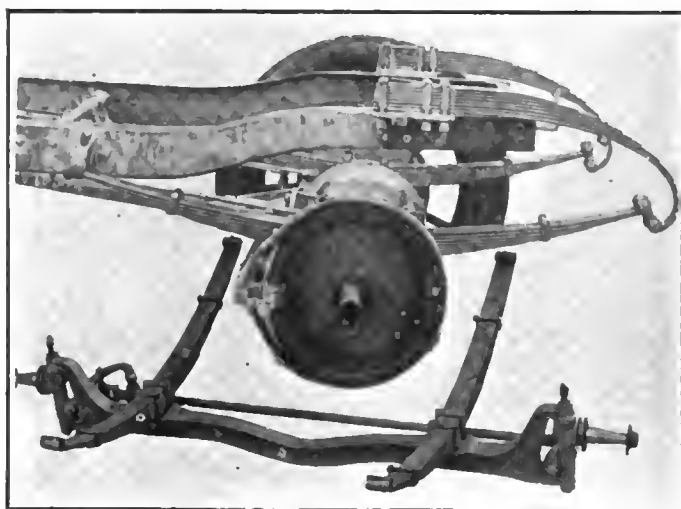

Fig. 8—Showing suspension of National front and rear axle, as well as brake construction and differential in perspective

of being cast integral therewith and the rear support S<sub>2</sub> is attached to the motor by means of long through bolts. Drain-cocks D and D<sub>1</sub> are provided, thus rendering it possible to drain off the water entirely from the cylinders. The compression cocks C<sub>1</sub>, C<sub>2</sub>, C<sub>3</sub> and C<sub>4</sub> are placed in the heads of the cylinder and can be operated by the knob K<sub>1</sub>, which passes through the dashboard and is attached to the rod R<sub>1</sub>, which in turn is attached to the arms of the cocks. In order to facilitate the timing of the motor a pointer P<sub>1</sub> is provided and the flywheel is marked with the various settings for the valves and the ignition.

The exhaust side of the motor is shown in Fig. 7, in which the timer T<sub>1</sub> can be seen. The fan pulley F<sub>1</sub> and water pump P<sub>1</sub> are driven by gearing from the half-time shaft, and the water is conveyed from the pump, which is of the centrifugal type, to the pipe W<sub>1</sub> and enters the cylinders at the points W<sub>2</sub> and W<sub>3</sub>, a piece of rubber tubing R<sub>1</sub> being placed between the two pipes to take care of any vibration. Tapered nipples are used on the intake, exhaust and water pipes, thereby doing away with all packing joints.

The pump shaft carries an extension E which drives the intermediate shaft I, which in turn drives the magneto. By undoing the strap S<sub>1</sub> it is possible to remove the magneto from its base B<sub>1</sub> and all alignment between magneto and pump is taken care of by the shaft I. Oil is poured in the base chamber through the large filler F, a cork float within the housing C<sub>1</sub> serving to indicate when the correct level has been attained by means of a small ball which is attached to the float.

Two sets of spark plugs, located in the valve caps, are provided, and besides the magneto ignition a separate and independent ignition is provided by means of storage battery, single vibrator coil and distributor. Either or both systems may be used at will. A double distributor, Splitdorf magneto, with two sets of plugs and storage battery is used on the roadster model, and this system fires both sets of plugs simultaneously, either battery or magneto. The carbureter is of the float feed type, with a 1 $\frac{3}{4}$ -inch connection on all models, except the roadster, which has a 2-inch connection. A metal strap attached to the base chamber holds the body of the carbureter rigid.

Oil is taken from the base by a pump and delivered to the sight feed on the dash, whence the oil is returned to the main bearings. A false bottom is fitted inside the base, forming troughs for the connecting rod scoops to dip into. A continual flow occasioned by the pump fills these troughs to a level sufficient to insure proper lubrication and prevent over-lubrication. When the level of the oil becomes higher than the standpipes it overflows and returns to the sump. The pistons and cylinders are lubricated by the splash of the con-

necting rods and above the main bearings cups are provided to maintain a constant flow of oil to these parts.

The clutch is a cone type and is shown in detail in Fig. 2. The aluminum member A is faced with a leather covering L, beneath which six flat springs are provided. These cause the leather to bulge at six points, thereby insuring an easy engagement. The spigot S<sub>1</sub> is drilled and tapped and accommodates the bolt S<sub>2</sub>; the spring S<sub>3</sub> is held in tension by the locking nut N, and disengagement is brought about by causing the collar C<sub>1</sub> to recede. A ball thrust B is provided to take care of the thrust during the disengagement. Attached to the disengaging arm there is a bracket B<sub>1</sub> which is fitted with a through bolt B<sub>2</sub>, the lower extremity of which is provided with a leather-faced surface. As the disengaging arm is operated by the clutch pedal the bracket B is caused to descend and to come into contact with the ring R<sub>1</sub>, which is attached to the main body of the clutch by set-screws S<sub>4</sub> and S<sub>5</sub>, thus preventing continued spinning of the clutch when disengaged and facilitating changing from one speed to another. The spring S prevents any gripping action of the clutch brake.

The transmission is of the selective type, giving three speeds forward and reverse. The shafts, as may be seen from Fig. 8, are carried upon annular ball bearings, and packing glands are provided so that oil can be used for lubrication instead of grease. A universal joint, shown in Fig. 2, is placed between the clutch and transmission, taking care of any disalignment that may be occasioned by the bending of the chassis frame, due to inequalities of the road surface as well as slight faults of assembly. The gear is supported upon two cross members of the chassis frame, as may be seen by referring to Fig. 1.

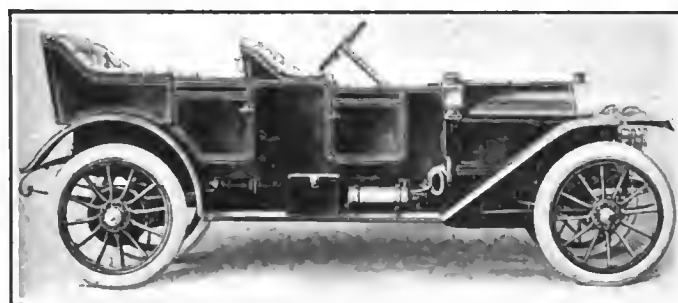

Fig. 9—Side view of seven-passenger, fore-door type of touring car and neat arrangement of accessories on footboard

Power is transmitted from the gearbox to the live rear axle by a 1 $\frac{3}{8}$ -inch propeller shaft enclosed in a casing extending from the rear axle housing to a forked joint at the forward extremity. This fork is hinged upon a bracket attached to a cross member of the frame, and the torque is taken up therein. A section of the live rear axle, which is of the full floating type, is shown in Fig. 11, from which it will be seen that roller bearings are employed throughout. This illustration also shows the method employed for operating the brakes, acting upon the rear wheel drums. By removing the cover over the rear axle it is possible to remove the differential parts.

The suspension in the National is taken care of by means of semi-elliptic springs at the front, attached to an I-beam axle, as shown in Fig. 8; the rear suspension, however, is of the three-quarter elliptic type and the method of attaching the springs to the chassis frame is shown in the same illustration.

The wheels are fitted with 36 x 4-inch tires, but the buyer has the option of choosing 34 x 4 1-2-inch on the speedway roadster and 37 x 4 1-2-inch upon the touring cars and the limousines.

MANY of the Sheffield, England, physicians have abandoned their horses and carriages and gone in for automobiling for practical use. Fifty per cent. of the cars in use in Sheffield are of the high-power touring type. The same rule prevails throughout the United Kingdom.



## To Fit Car to Buyer

(Extract from a paper read before the British Institute of Carriage Manufacturers in London, Sept. 4, 1911, by Mr. Herbert Austin.)

IF at the commencement of the automobile era it had been possible to realise the extent of its use to-day, and of the demand for speed and luxury, closer attention would no doubt have been paid to the creation of a vehicle designed to meet the entirely different conditions caused by the advent of the new means of locomotion. This evolution is going on every day, and perhaps the gradual change is for the best, as had it been too sudden the public might have objected more strongly than it did, and the conditions appertaining to the use of the automobile would have been so much more difficult to cope with.

The demand to-day is for seats to be low, and they must, therefore, be sloped downwards toward the back. This means taking up more room lengthwise on the chassis, and unless the accommodation at the back can be curtailed the body must overhang more or the chassis will have to be lengthened to conform with the requirements.

To be able to provide for variations in the dimensions of drivers and the positions they wish to be fitted, an adjustable seat has been designed by the author. This seat can be placed in any position that could possibly be required, and attached to it is a steering column and pedals. All the holes for adjustment are marked so that a record can be taken of the position most convenient to the customer and enabling the manufacturer to copy the dimensions found in the car delivered to the buyer.

Of course, the positions allowable with a standard body are limited, and these limits are noted on each design. Some provision would have to be made in the steering column and

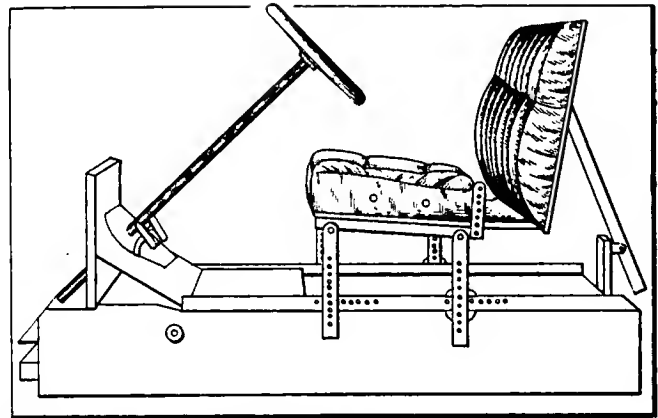

Adjustable seat, with dummy steering wheel and pedals, to enable the builder to fit the car seat to the buyer

## Heat Due to Combustion

ACCORDING to accepted authority, the fuel values in British thermal units per pound of the contents of gasoline are as follows:

Carbon burned to carbon monoxide.....	4,100 B.t.u.
Carbon burned to carbon dioxide.....	14,500 B.t.u.
Hydrogen burned to water.....	62,032 B.t.u.
Hydro-carbons burned to carbon dioxide.....	20,000 B.t.u.

From the above it will be seen that a small proportion of hydrogen in the exhaust products of combustion of a motor represents an enormous weight. It will also be noted that unburned gasoline in the exhaust represents a very considerable waste, and that carbon monoxide, if it exists instead of carbon dioxide, lowers the thermal value of the fuel as used from 14,500 to 4,100 British thermal units.

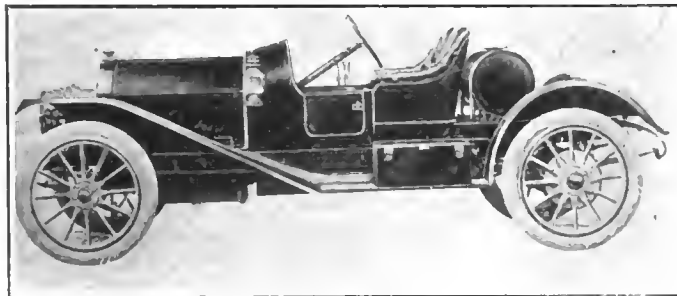

Fig. 10—Showing the National speedway roadster, indicating comfort for the driver and showing large gasoline tank

## Correct Tire Pressures

There is great variation in the pressures recommended by the different tire manufacturers. The following is probably a fair average for ordinary loads on the wheels:

Diameter of tire, Inches	Air pressure in tire, Lbs. per sq. in.
2½	45
3	55
3½	65
4	75
4½	85
5	90
5½	95

Lower pressures are used by some, especially for light loads. The pressures run considerably higher in several cases for heavy loads.

pedals for each make of chassis, but this would not be a big matter.

The space between the seatboards and the footboards was always considered a convenient place to put spares and tools in, but this is gradually disappearing, the total height of the seat being now much lower and the cushions much thicker than they were formerly.

On a long journey when driving a car having a low-confined seat considerable discomfort is sometimes experienced in being forced to keep to one position, and in hot weather the discomfort is accentuated. With the higher seats and more upright steering column formerly used, one could move about a little, and in this way prevent to some extent the fatigue arising from continued driving.

An adjustable driving seat is no novelty on a horsed-carriage, and as it is infinitely more necessary to be able to sit in a suitable position to drive a car, an adjustable driving seat will become popular on some types of automobiles as soon as the public awakes to their advantages.

Where both the brake and change-speed levers, or only the former are outside the front seat panel, the height of the arm rest to driver's seat is important, particularly on some makes of chassis. Even an extra inch will make it extremely uncomfortable to operate the levers which are outside the confines of the car body.

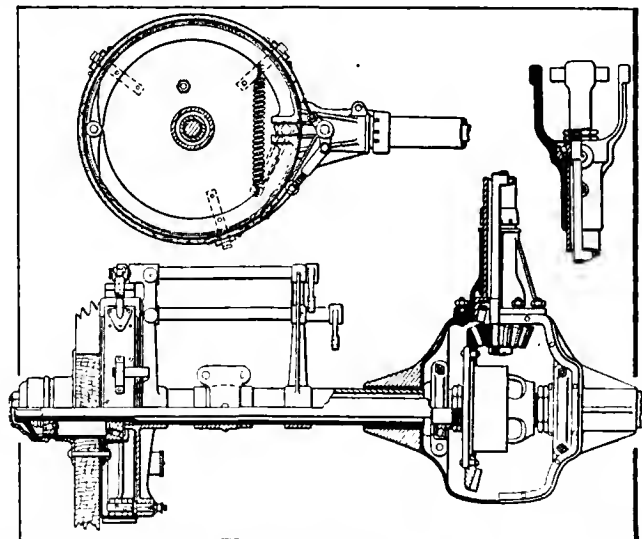

Fig. 11—Transverse section through National rear axle assembly, showing details of brake construction and differential

# Letters Answered and Discussed

## Hole in Throttle Valve

EDITOR THE AUTOMOBILE:

[2,842]—Would you please inform me how to fit a set screw or other device on the throttle valve of the motor so that when the throttle is closed as far as it will go the engine will still turn over at slowest speed. The valve is of the butterfly type.

CHAS. SINGER.

New York City.

With a butterfly valve the simplest way of making the adjustment you speak of is to cut a small hole in the valve, as shown in Fig. 1. The hole may be made very small at the start and gradually increased in size until the engine will just carry the car at the lowest possible speed on level ground.

It would be too much of an undertaking to go about fitting a set screw in the case of a valve such as this, and while it would have the advantage of being adjustable at any time this advantage has not enough weight to overbalance the difficulty of making a home-made fitting of this nature.

## Engine Loses Power

EDITOR THE AUTOMOBILE:

[2,843]—Since THE AUTOMOBILE offers to give its opinion to subscribers as to the nature of the trouble and the remedy therefor, when the motor or other working parts of the car are out of order, I am taking the liberty to ask a question.

There are a number of car owners besides myself who are troubled by the fact that the engines will run very well while new, but after they have been run for a short time the advancing of the spark fails to augment the speed of the engine, and the throttle alone is of use. Consequently

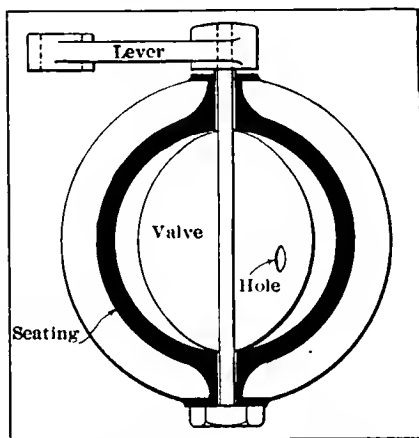

Fig. 1—Butterfly throttle valve with hole cut in valve to permit of slow running

*The Editor invites subscribers to communicate their automobile troubles and personal experiences, stating them clearly on one side of the paper. If the nature of the case permits, send a sketch, even if it be rough, in order to assist to a clearer understanding. Each communication will receive attention in the order of its receipt, if the writer's signature and address accompany it as an evidence of good faith. If the writer objects to the publication of his name, he may add a nom de plume.*



the engine has not the full power it had at the beginning.

PHILIP NADIG.

Allentown, Pa.

Any motor will run at its best if the spark is advanced as far as possible without the slightest sign of a knock being ob-

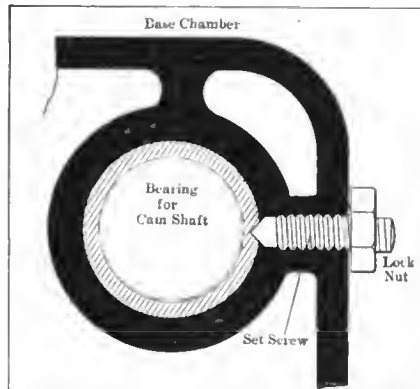

Fig. 2—Manner of fitting set screw to hold camshaft bushing in place

tained. If the spark is at this point while running on level ground the greatest effort possible from the engine is being put into driving the car. When ascending a hill, however, the spark will be considerably retarded owing to the slower motion of the motor. The reason that an engine falls off in power after it has been run awhile is that the compression has become leaky owing to piston or valve leaks. The latter are often caused by a particle of carbon which has become lodged beneath the valve. A pitted valve will often be the cause of a considerable loss of power, and the defective member cannot well be remedied by grinding, as the pits will be deeper than it is advisable to grind. In a case of this kind it is best to purchase a new valve at once, or if within the makers' guarantee have them replace it.

Insufficient lubrication is another cause of the loss of power. A new car always requires more lubrication than a car which has been run for a length of time.

Worn gears on the camshaft drive often cause a loss of power owing to the fact that they alter the valve timing.

## Loose Bearing Bushing

EDITOR THE AUTOMOBILE:

[2,844]—The camshaft bearing bushing on my car is loose and shifts its position while the engine is in motion. The trouble is not at all serious, as I am well aware; still I would like to fasten the bushing in position, as I am afraid it will wear considerably if left as it is. I am therefore taking the liberty of asking you the best way to remedy it. Do you think a pin should be driven into the bushing?

L. T. MOOSE.

Canton, Pa.

A pin would not be so advisable as a set screw, which could be fitted in the manner shown in Fig. 2. The screw is so slotted as to be turned by a screw driver, a lock nut is then placed over the screw in order to hold it in place while the engine vibrates. In drilling for the set screw care must be taken that the indentation in the bushing is not made so deep that it penetrates the metal. The correct distance is shown in the illustration.

## To Darken Brass

EDITOR THE AUTOMOBILE:

[2,845]—I would like to have you inform me if there is any coating which could be applied to the brass parts which would eliminate the necessity of so frequently polishing it. In one of your recent issues you told of a coating which applied to such parts as could be removed from the machine and heated, but this of course is not applicable to windshields, etc. Any information you care to give me will be appreciated.

F. D. MARTIN.

New York City.

Prepared as here given lacquer will prove efficacious in renovating the bright work, but it is necessary to prepare the surfaces to be lacquered if the results are to be satisfactory. For the surfaces what is needed is a high polish and absolute freedom from grease. The lacquer may be prepared thus: Bleached shellac, 60 grams; Manila copal, freshly powdered, 60 grams; gum mastic, 60 grams; absolute (grain) alcohol, 1 kilogram; coarsely powdered glass, small quantity; allowed to stand for (frequently shaking), 14 days; boracic acid, 1 gram. Filter and use, the best plan being to apply repeated thin coats.

Any desired color may be given to the lacquer by adding aniline dyes. A very little of the dye of the color selected will serve for the purpose. Red and blue will form clear solutions; green must be han-

died cautiously; it may have to be filtered; yellow is a good dye to handle. In applying lacquers it is desirable to go about it in the same way as shellac is applied—thin coats, deftly applied by means of a suitable brush, with very little rubbing; it will become tacky if it is fussed with very long.

### To Open Crankcase Drains

Editor THE AUTOMOBILE:

[2,846]—Kindly tell me of a fitting which could be attached to the drain pipes on the crankcase of my automobile so that they could be opened without getting beneath the car. The way they are fitted at present makes them annoyingly inaccessible, especially if one has a good suit of clothes on at the time.

The drain cocks are fitted to standpipes which rise to the correct splash level, and hence when these drains are opened the excess oil will drain away. Any information you gave me would be greatly appreciated.

Chicago, Ill.

SUBSCRIBER.

A handy method of opening the drain cocks is to have them arranged so that they are all opened at once. This is done by connecting all the cock handles to a rod and fitting a ring at the end, as in Fig. 3. To this ring a wire is fitted which is run to the front end of the car, terminating just below the radiator. In case it is desired to drain off the surplus oil, the ring on the end of the wire below the radiator is pulled and all the cocks will be opened. The wire is stiff enough so that the cocks can be pushed back to their closed position, which will be determined by means of a stop. If it is desired a spring may be fitted which will hold the rod in a closed position unless there is a pull on the wire.

### Raises Magneto Question

Editor THE AUTOMOBILE:

[2,847]—What advantage has a high-tension magneto over the low? As I understand it, an engine will run just as well with a low-tension magneto as with a high, and at the same time one can crank on a low and not on a high. If the low is just as good, why the greater cost of the high?

Bango, Texas.

J. K. STONE.

The high-tension magneto is practically nothing more than a low-tension magneto with a coil in the same casing. Hence the high-tension will cost more than the low since it is more complicated. Low-tension ignition, such as is used with the make-and-break system, is not as simple as the spark plug used with the high-tension system. In order to use a plug with a low-tension magneto a coil is necessary to produce a high-tension current.

The engine can be cranked when fitted with a high-tension magneto.

### Air Cock on Intake

Editor THE AUTOMOBILE:

[2,848]—Several automobile drivers of my acquaintance have fitted a small pet-cock in the intake pipe, about 4 inches above the carbureter. After starting the engine with this pet-cock closed, and then opening it to obtain more air, a very noticeable increase in the speed of the engine will result. Again when a car is running at a speed of 20 miles per hour on the road, when this pet-cock is opened, the speed will increase from five to seven miles per hour.

The device has been tried on a variety of cars and in all cases the results have been practically the same—a greatly increased mileage per gallon of gasoline.

Kindly advise what you think of the idea and whether any bad effects will arise from its use.

FRED A. MOORE.

Croswell, Mich.

That the device works well after having

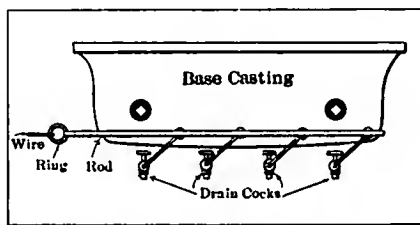

Fig. 3—How cocks may be connected so that they can all be opened at one time

been tried on several cars seems to indicate that it is of some merit, and it is natural when the reasons for it are examined. The modern carbureter, although a marvel of automatic flexibility, has to be adjusted so that all speeds will be equally well taken care of. If the carbureter were set so that the highest possible efficiency were obtained at high speeds it would probably be impossible to start the engine.

The auxiliary air valve was invented for the purpose of supplying more air to the mixture after the engine gathered speed, but even with this valve the maximum efficiency cannot be obtained at every speed.

One objection to the cock fitted as you suggest is that the dust in the air will be drawn into the cylinder and will do some harm after awhile. If gauze were fitted to the cock and a handy means of varying the opening were placed on the dash so that it could be operated by the driver, it would be a useful adjunct in the hands of an able operator who desired to get all the good possible out of the car.

### Gets Too Much Oil

Editor THE AUTOMOBILE:

[2,849]—I would be greatly obliged if you would tell me how to lessen the supply of oil given by the plunger pump in the oiling system of my new car. The supply is just enough greater than what is necessary, to make the motor smoke very

unpleasantly. If you could help me out of the difficulty by publishing a solution of the problem in an early issue of your valued paper it would be appreciated.

Tuckahoe, N. Y.

H. W.

Remembering the fact that it does not harm a new car to receive a little excess of oil, the adjustment may be made on the pump itself by regulating the length of the stroke. On nearly all plunger pumps there is a nut which may be turned down, thereby shortening the stroke. Since the amount of oil delivered by the pump is exactly proportional to the length of the stroke of the pump, this regulation will correct the fault.

### Clutch Is Fierce

Editor THE AUTOMOBILE:

[2,850]—Would you kindly tell me how to remedy a clutch which picks up very suddenly? The clutch is of the leather-faced cone type and instead of picking up easily, as a clutch should do, it will grip with a very jerky pull as soon as it is engaged. If there is anything I can do to make the clutch less fierce I would appreciate it if you would direct me.

Tottenville, N. Y.

L. K. H.

The repair can be very readily made at home if the garage is equipped with the average amount of tools, or if they can be borrowed or bought in the neighborhood. Referring to Fig. 4, a drilled piece  $P_1$  is bolted to the male member of the clutch in such a way that  $P_1$  is parallel to  $M$ . A tube  $P$  is placed about the bolt which passes through  $P_1$  and a spring is inserted, so that the leather  $L$  is held against the flange  $B$  of the flywheel  $F$ . The bolts  $B_1$  and  $B_2$  are fastened tightly in order to prevent any working loose, while the bolt which passes through  $P_1$  is held in position by a lock nut  $L_1$  by means of which any adjustments may be made permanent. There should be at least four of these inserts placed upon the clutch in order to secure a uniform effect.

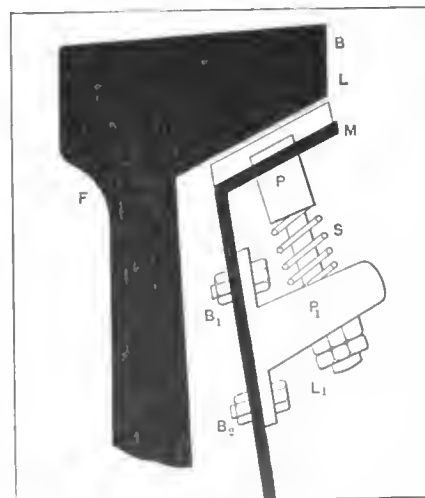

Fig. 4—Showing method of inserting springs in clutch to give easy engagement

# Little Bits of Motor Wisdom

## Pertinent Pointers for Repairman and Driver

**USE OF FEATHER OR KEY**—Where one shaft is forced to slide upon another and it is not desired to go to the expense of squaring the shaft for the length that the slide is required, a key or feather of the type illustrated in Fig. 1 is fitted. With a fitting of this nature the outer or sliding piece may work in either direction with very little resistance to its motion if the slide be well lubricated. This piece of mechanism is used to a large

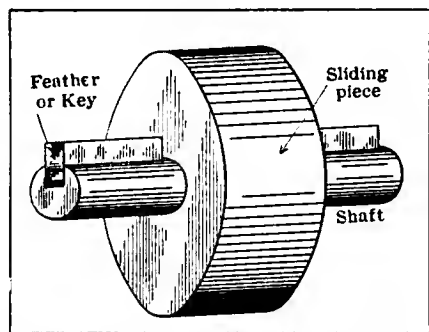

Fig. 1—Showing method of arranging feather or key as a guide for sliding piece

extent in change gear devices, the loose collar slipping along the shaft in either direction according to the motions of a hand lever which is fitted in such a manner that the operation of moving the different gears in mesh is in accordance with the conditions under which the automobile is traveling.

In operating the sliding sleeve by means of a lever, the usual method is to have a forked arm which touches a collar so that the sleeve may be moved in any direction. At the same time the fork is free to have the sliding component which will naturally be a part of the motion where the arm turns about a pivot and, at the same time, imparts a straight-line motion to another shaft.

**THE GEAR PUMP**—In place of the plunger pump with its ball check valves, the gear pump is finding favor with many manufacturers. It is very simple to arrange a satisfactory drive for the gear pump, since it is driven with a rotary instead of a reciprocating action. Instead of the necessity of an eccentric arrangement to produce the straight line or reciprocating motion necessary in a plunger pump, the gear pump can be driven directly from the camshaft or other rotating part by means of simple gearing.

The pump is shown in Figs. 3 and 4,

which illustrate the exterior and a section through the dotted line shown on this cut. The oil enters through the port marked "suction" in the sectional view, and is taken around by the wheels to the delivery side; the oil cannot pass between the teeth in the quantity that it is drawn in by the suction, so it is squeezed out through the delivery port.

With the method of delivery employed in this type of pump it is evident that a large head could not be overcome, as would be the case if the oil were to be lifted to any great height. For the requirements of an oil pump, however, the method is very satisfactory for all cases, as the pressure required does not as a rule amount to more than three or four pounds where the force-feed system is used.

If the rotary gear pump is driven off the camshaft by means of a gear and straight shaft, it is a very desirable feature to insert a spring connection in the shaft so that, should the pump jam, the spring release will work and allow the pump to remain at rest without any of the parts having been broken. This is effected by putting in a spring which will be strong enough to hold the shaft while turning, but which will, in case the pump should jam, break or in some cases slip, so that it is no longer a means of rigid connection, but allows the upper part of the shaft to turn freely.

Where the gear pump is used it is very customary to fit a by-pass as a means of regulating the quantity of oil delivered to the various bearings. The by-pass is so constructed that by turning a lever a greater or less amount of oil may be allowed to pass through it; but when all the oil that can possibly be directed through the by-pass is allowed to flow through this outlet, there will still be a sufficient quantity passing through the oil leads to lubricate the bearings at slow speed. This is done as a matter of precaution so that all the oil will never be accidentally shut off from the engine while the latter is running.

The pressure on the gauge, where such is fitted, in conjunction with this type of pump should be allowed to register a little more with a new car than with one which has been run long enough for the bearings to have worn themselves to a good running fit. The pressure required in city driving will be about a pound less than for the country, as an average. Very often the overflow from the bearings lubricated by the force-feed system forms the basis of an auxiliary splash system.

**TREMBLER POINTS OUT OF LINE**—It will sometimes happen that the contact points on the magneto timer are not properly in line, and unequal wear will result which will greatly hinder the delicacy of adjustment which is such a necessary feature in this part of the coil. In the accompanying illustration, Fig. 2, C is the primary core, T the trembler, P and P<sub>1</sub> the contact points, N and N<sub>1</sub> the lock nuts and S the set or adjusting screw. The trembler is held at the post H. In a case of this nature a small piece of metal should be brazed on the trembler and then filed square so that when vibrating there will be equal wear on all parts of both contact points.

The adjustments on the set screw S should be made so that when the circuit is closed a continuous droning hum will be given forth by the vibrator. A rattling sound is an indication that the vibrator is working too slowly against the spring. If the latter is the case the tension on the spring should be relaxed by loosening the adjusting screw. When the proper adjustment is made as regards the contact points and the spring tension the lock nuts are tightened into position so as to secure a

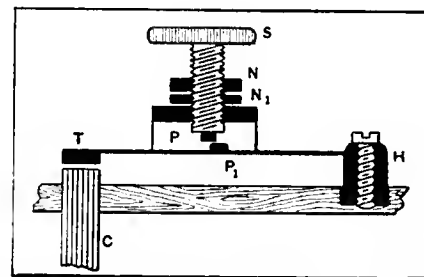

Fig. 2—Illustrating a case where the trembler contact points were out of line

permanent adjustment. The lock nuts are very necessary here, as the continual vibration would soon loosen the set screw if there were no method of securing it in place.

**SHORT CIRCUITS**—A spark, in leaping the gap between the two sparking points of the spark plug, overcomes a large resistance even if the operation takes place in the open air; but when the air is charged with hydrocarbonic gas this resistance is increased. A slightly compressed charge of gasoline and air may be fired by a spark which would be too weak to fire a charge which has been compressed to the 70 pounds per square inch pressure which

is the general rule in automobile engine practice. It is therefore evident that the resistance is higher in the compression space of the motor than it is in the open air, so that an apparently good spark may not be a spark at all after it is enclosed within the cylinder. This loss of the spark when acting through the compressed medium is due to a short circuit which is caused by the fact that the current, seeking the path of least resistance, finds a way of passing into the ground without crossing the spark gap. The insulation might not leak at all under atmospheric conditions, but just below the pressure at which the spark crosses the gap the current finds a spot in the insulation which offers less resistance than that encountered at the sparking points.

If this leak takes place in the coil it will generally be beyond the scope of the amateur to make his own repairs. A new coil will have to be bought if the damage has gone far, as the internal spark will burn out the surrounding insulation in a very short time. If the leak is at the spark plug, as is very often the case, owing to a cracked porcelain or defective mica insulation, a new plug will quickly eradicate the difficulty. Defective insulation is apt to cause a short circuit at any place along the line. This is especially the case in high-tension wiring, which should be carefully watched, as a little dampness or chafing against moving parts of the motor may be responsible for the damage.

A fault which occurs with dry batteries at times, if they are not carefully packed, is that they are likely to rub together owing to the vibration of the car and thus wear the cardboard boxes which hold them and

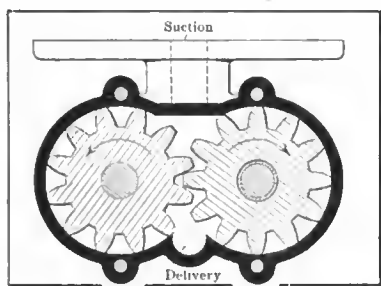

Fig. 3—Section through gear pump at dotted line shown in exterior view

allow the zincs to come in contact with each other. This, of course, does not happen very often, as the batteries as a rule are held in a tight box, which does not permit any chafing action to take place between them.

**KEEP BREATHER PIPES CLEAR**—As the piston descends, the air beneath it is compressed and hence offers a resistance to the motion of the engine. In order to reduce this resistance breather pipes are fitted on the motor to allow of a free passage of the air in either direction. The air will flow in and out of the crankcase according as it

is sucked in by the ascending piston or blown out by the descending. When the breather pipes become choked, resistance is offered to the free passage of the air and hence work will have to be done by the motor in overcoming this resistance. This work is a direct loss since it is put into something which is not necessary and is no factor in driving the car.

The breather pipes are generally fitted with a strainer to keep dirt from entering the crankcase. Very often the strainers fulfill the double duty of keeping the crankcase clean and straining the oil which is put into the crankcase, as the oil is often supplied by this means where the splash system is used. A periodic cleaning of this part would add to the efficiency of the engine.

**FIRING AT CORRECT TIME**—Next to having the cylinders all firing at the same relative piston position, the greatest item of importance in the motor is to have the charges ignited at the proper time, or when the piston is at the point most suitable for developing the greatest power.

The ideal position for the maximum explosive effect would be at top dead center; but since the internal combustion engine revolves so rapidly, this is a condition which can never obtain even in the best designed engines. When the gas is first ignited, it rapidly expands owing to the heat of its own combustion. The flame is taken up by the surrounding particles of gas and is passed through the whole charge. This takes place very rapidly, but not rapidly enough to obtain the expansion at constant volume which would be the ideal state of affairs. Besides the lag in the explosion there is an appreciable lag in the passage of the electric current through the secondary winding, and therefore when the engine is traveling at high piston speeds the spark lever will have to be advanced a certain amount on the quadrant to allow for this lag. The sooner the charge is ignited, the sooner the maximum pressure will be developed in relation to the stroke and hence the greater the power that will be produced by the motor.

The condition of the mixture and the intensity of the spark are very large factors in determining the proper and most effective firing point. In driving the car the proper position of the spark lever will vary with the conditions under which the car is working, and it is largely a matter of experience on the part of the driver to have the spark in the proper position to obtain all the power of which the motor is capable. As a general rule the greatest power is obtained with the greatest spark advance possible, without having the slightest sign of a knock. In special cases, as in hill climbing or in starting the motor, where the engine turns over very slowly, the spark is retarded, as a back-fire in either of these cases would have had results. In cranking the machine if the

spark has not been sufficiently retarded a serious accident may occur that would result in a broken or severely strained arm. Cases have been known where death was caused by this same occurrence. In the case of a hill, if the charge should be ignited too soon the power would be expended on the piston at the wrong time and hence would be apt to stop the engine.

When firing too late the exhaust pressure is far above what it should be; and since the temperature of the gases depends directly on the pressure, they are also far too hot. This heats the cooling water of the engine to such an extent that it frequently boils, escaping in the form of steam from the radiator cap and other points where such leakage is possible. Besides the overheating there is a loss of power in running the engine with the spark too late, as the high terminal pressure re-

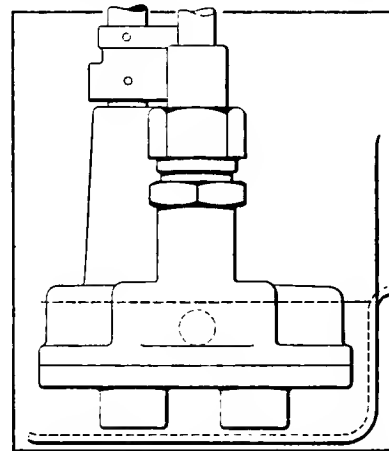

Fig. 4—Exterior of gear pump often used in connection with force-feed oiling

duces the mean effective pressure and hence the horsepower produced by the motor.

**WORN AND LOOSE GEARS**—Where gears have been allowed to wear it is very often the case that they are not in the same relative position with each other that they were when the parts were first assembled. An instance of this kind may be taken in the case of a camshaft whose driving pinions have become so badly worn that in revolving the camshaft lags far behind the position taken when the machine was new. The same may be said of a gear which is loose or a cam which has worked loose and hence is in a different relative position from that formerly occupied.

Where the gears have worn to any extent the action, instead of being smooth and unbroken, may proceed in a series of jerks. This will result in a rattling noise which will readily make itself heard above the sounds given forth by a smooth-running car. The timing of the operation which depends upon such worn or loose parts is very sure to be incorrect. In the case of a camshaft the opening and closing would both be late.



# My 1912 Automobile

## Some Conceptions of What the Ideal Car Should Be

### Illustrates His Ideal

#### EDITOR THE AUTOMOBILE:

The "1912" automobile should be about 40-50 horsepower, having an en bloc T-head motor with a 4 1-2-inch bore and 6-inch stroke. All valves should be enclosed with dust-proof covers. Magneto, oil pump and water pump should be mounted on a cross shaft at the front. The fan should be bevel gear driven, thus doing away with all possible belt troubles. Ignition should be by means of high-tension magneto and storage battery. Lubrication should be of splash type with an oil pump to raise the oil to the top of the crankcase. An ample sized float-feed carbureter with an air and gas adjustment on dash would be required.

The clutch should be of the contracting band type, thus doing away with thrust against motor and other bearings, and permitting of easy adjustment. The gearset should be of the type where gears are always in mesh, thus doing away with possibility of stripping gears and permitting of a comparatively noiseless shift of gears. The transmission shafts should be mounted on roller bearings, and case to be cast with arms to bolt to rear arms of motor, thus making a unit power plant. Drive should be by shaft with two universal joints.

The wheelbase should be about 120

inches, allowing ample leg room and giving easy riding effect. The springs should be semi-elliptic front 42 x 2 1-2 inches and three-quarter elliptic rear 44 x 2 1-2 inches. The tires should be 36 x 4 inches front and rear, Q. D., on demountable rims.

The front axle should be of drop-forged I-beam type with roller bearings in the wheels, and steering connections above and behind the front axle. The rear axle should be full floating with all roller bearings, and be of a single piece of pressed steel with removable cap to permit of easy access to the differential and bearings.

The control should be by means of an 18-inch steering wheel and adjustable worm and sector. The gear shift to be operated by a lever at right side in H quadrant. The pedal arrangement is standard. Spark and gas operated on top of wheel and foot accelerator. The emergency brake to be worked by side hand lever which releases the clutch when applied, thus lessening wear on transmission shafts.

The body should be fitted with seats having high backs and low bottoms and long leg room provided for, thus making touring more comfortable. (Other details can best be seen from the accompanying drawings.)

The car should be equipped with full set of electric lamps and lighting system, electric signal, top, windshield, shock absorb-

ers, spare rim, tools and other minor conveniences.

This car, weighing probably not more than 2,500 pounds, and with first-class materials used throughout, should cost about \$2,500 f.o.b. the factory.

Passaic, N. J. JOSEPH A. LANGE.

### Working Parts Enclosed

#### Editor THE AUTOMOBILE:

The following is my ideal for a 1912 machine:

The motor should have four cylinders with 4 1-2-inch bore by 5 1-4-inch stroke giving a conservative rating of 32 horsepower. The cylinders should be cast en bloc with valves in the head operated by a single overhead camshaft driven by means of a silent chain from the crankshaft. The ignition should consist of high-tension magneto and storage battery, each system being entirely separate. The lubrication should be of the force feed type through hollow crankshaft. The crankshaft could be carried on two large ball bearings.

All working parts of the motor should be enclosed and protected from dirt. A large cap could fit over the valve mechanism and protect it from grit.

The clutch should be of the multiple-disc type and should run in oil. The clutch should be in the same housing as the transmission and should be located amidships.

The transmission should be four-speed selective type, with direct on third, and should be fitted with ball bearings.

The drive should be by shaft, with two universal joints to a full floating rear axle with nickel steel driving shafts. The front axle should be of I-beam section and should have generous steering knuckles. In fact, all the steering parts should be made strong and easily adjustable for wear.

The wheels and differential should run on large ball bearings.

The frame should be underslung and in-swept in front. It should be supported by long, flat, semi-elliptical springs both front and rear and the springs should be fitted with shock absorbers.

The tires should be 36 x 4 front and 36 x 4 1-2 rear and mounted on demountable rims. The wheelbase should be 115 inches.

Control should be within easy reach and should be on the right-hand side.

The body should be of the two-passenger torpedo type with gasoline tanks and room for tires on rear deck.

The equipment should consist of top,

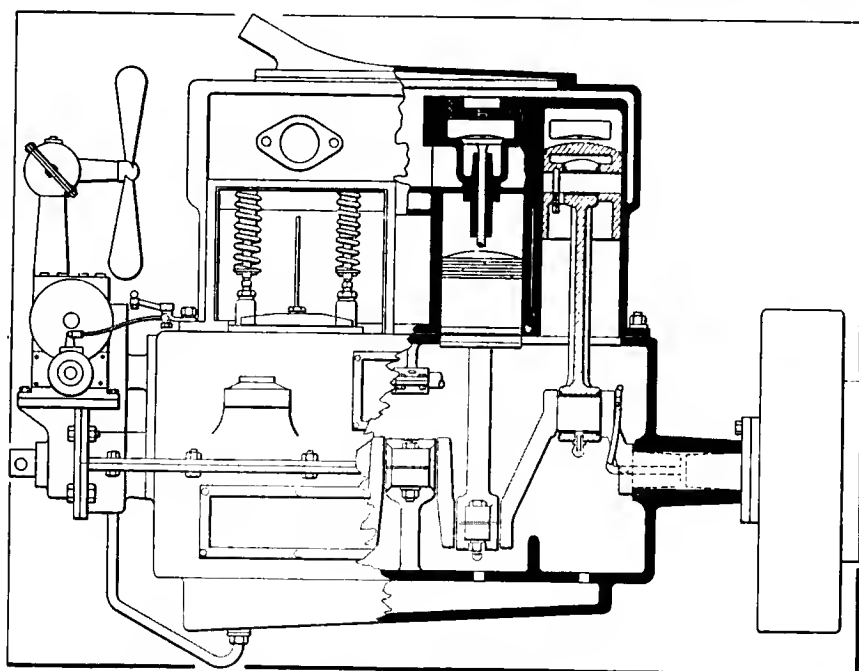

Fig. 1.—View of motor as drawn by an "Automobile" reader in illustrating his ideal car

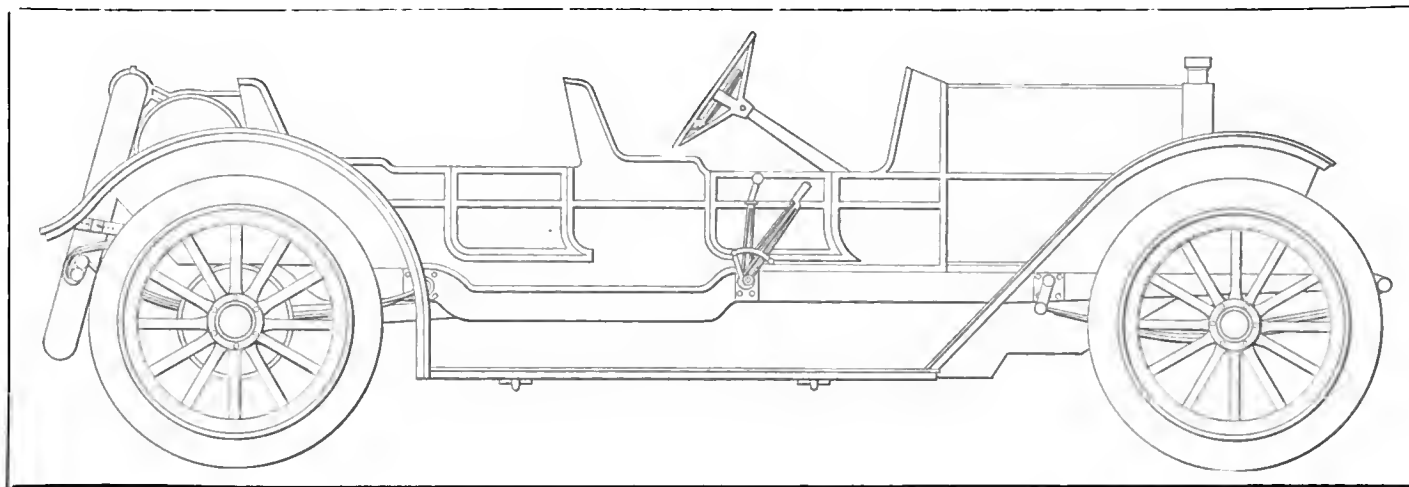

Fig. 2—Type of body suggested by a reader of "The Automobile" in describing his ideal 1912 car

windshield, speedometer, clock, five electric lamps, electric horn, generator and battery for horn and lamps, shock absorbers, and demountable rims with two extra rims.

As this car should be of the very highest grade its price could scarcely be below \$3,750.

MARTIN BURKELMAN.

New York City.

### Want Five Speeds

Editor THE AUTOMOBILE:

This is, in brief, my conception of the 1912 model car. The motor should have four cylinders cast in pairs with a bore of 90 mm. and a stroke of 180 mm (3 1-2 x 7 1-2 inches) and a nominal horsepower of 20.

The ignition should be by means of high-tension dual magneto system and the lubrication of the force-feed type, the pump being integral with the motor and with no connecting splash. Each part should be oiled separately. The motor should be equipped with either a Zenith or Claudel carbureter and should deliver its power through a leather-faced cone clutch.

The body should be supported upon semi-elliptic springs and I-beam frame members, the rear axle being of the semi-floating type. The wheelbase would be specified as 137 inches. Transmission should give five forward speeds and a reverse.

The motor should be equipped with a self-starter and motor-driven tire pump, while the steering wheel should be fitted with a locking device. A speedometer should also be carried and the brakes controlled by pedal and hand lever.

The body should be a four-passenger type fitted with an external exhaust pipe (without muffler) running along the foot-board. Right-hand drive should be fitted, with the levers outside the torpedo body. The hood and body should be in exact alignment, and the door should have the fastening locks inside. The gasoline tank should be located partly under the front seat and partly in the tonneau, furnishing

a foot rest for the passengers in the rear compartment. The rear seat foundation should be located directly on the chassis, with tool boxes under the floor of the rear platform of the car, one on each side of the drive shaft. A double extension hood should be fitted with two headlights, two sidelights and a rear lamp—all of the electric type. The glass front should be in two pieces, coming over the steering wheel. Price \$2,000.

Here are some reasons for my choice: Long-stroke motors (to my mind it ought to be 1 to 2), are nervous motors; they pick up speed much quicker than the

short-stroke type. I own a motor with an 80-millimeter bore and 160-millimeter stroke and it performs extremely well. I consider detachable wire wheels a luxury and believe their worth has been frequently demonstrated. Leather cone clutches are the smoothest for starting in city traffic. The five-speed transmission is a 1911 innovation which has made good in the Boulogne light car races, especially for long-stroke motors. External exhaust pipe (which can be made so as to avoid all noise) would prevent heat invading front of torpedo.

R. DE BEAUDIGUES.

Natoye, Belgium.

### THE AVERAGE CAR

The invitation to our subscribers to describe their ideal 1912 car has struck a popular chord. The responses show a wide appreciation of the salient points of car design and a knowledge of the points which tend to reliability and comfort. THE AUTOMOBILE hereby continues the invitation to its readers to mail in their conception of the features which should be embodied in next year's car. The information given should include such points as:

Horsepower	Stroke	Drive	Front axle
Cylinder type	Ignition	Springs	Control parts
No. of cylinders	Lubrication	Wheelbase	Body features
Cylinders, how cast	Clutch	Tire sizes	Equipment
Bore	Gearset	Rear Axle	Price

In addition to giving these details the reasons for your points of selection should be stated concisely and clearly.

As a benefit in the matter of comparison some details of the average cars for 1911 are given below.

Each communication must be legibly written on one side of the paper only; it must be properly signed with the writer's full name and address, and if the writer does not wish his own name to appear in print he may request the use of any nom de plume.

Any reader desiring to make line drawings, showing details of his ideas of his car or some of its parts, is requested to do so.

Editor THE AUTOMOBILE.

### DETAILS OF AVERAGE 1911 CARS WHICH WILL ENABLE READERS TO MAKE COMPARISONS IN DISCUSSING 1912 MODELS

	\$1,000 and there- abouts	\$1,500 and there- abouts	\$2,500 and there- abouts	\$4,000 and there- abouts
Horsepower	20.5	29.525	35	43.66
Bore	3.98 inches	4.19 inches	4.40 inches	4.875 inches
Stroke	4.12 inches	4.64 inches	4.98 inches	5.39 inches
Wheelbase	100 inches	114 inches	119 inches	124 inches
Front tires	31.4 x 3.3	33.1 x 3.8	35 x 4	35.7 x 4.27
Rear tires	31.4 x 3.3	33.1 x 3.8	35 x 4.1	36.7 x 4.55
Number of cylinders	Four	Four	Four	Four
Cylinder type	L-Head	L-Head	L-Head	T-Head
Cylinders cast	Pairs	Pairs	Pairs	Pairs
Ignition	Dual	Dual	Dual	Dual
Clutch	Disc	Multiple disc	Cone	Multiple disc

## Digest of the Leading Foreign Papers

**M**OTOR CULTIVATORS, HARROWS AND HOES must pay for themselves during the short season when there is need for their services, but in a large country with a single language the season may be considerable lengthened if the owners of such agricultural machines travel with them from South to North, as is now done with threshing machines in the United States. Under different circumstances it is highly desirable from an economical viewpoint that the motor element in the machines be detachable and applicable to other purposes. Their utility generally depends mostly upon the possibility of performing a great deal of work with them while the weather is favorable and with a minimum of human labor. In the case of beet culture and for other crops where each plant should preferably be isolated, the machines can never do as thorough work in weeding and hoeing as may be done by human hands, as they cannot work so near to the plants, but, as compared with machines drawn by animals, they destroy a great deal less of the desirable growth in passing through a field, and the scarcity of human labor in the country, the world over, has made the mechanical problems involved in the application of the motor principle to this class of work as important as any which are encountered in the automobile industry. Taking this view, a number of local automobile clubs in France in conjunction with several agricultural societies arranged for a competition of motor hoeing machines in the fore-summer of 1911 with the co-operation of the syndicate of French sugar manufacturers. The trial took place in a beet field of 11 hectares adjacent to a highway lined with trees, and a heavy rain on the preceding evening had left the soil very wet and slippery, especially under the trees. Nevertheless, the three machines which were entered for the competition performed the work expected of them so nearly satisfactorily that a few changes in their construction should suffice for introducing them broadly in agricultural work. The largest machine in the trial was one made by the Bajac Machine Company, of St. Quentin. It works six rows with a two-cylinder motor of 8 horsepower, weighs 1,400 kilograms and requires two attendants, one who steers the machine from a seat and another who operates the right-angled hoeing irons according to the requirements in the field. For the turns, where every other machine in this class is difficult to manage so that the rows of plants are not injured or the soil upheaved, this machine has a special arrangement whereby the inner wheels turn on metal sheaves which after the turn are again raised and secured to the frame. The field in this case had been prepared with a four-row drilling machine and planter, and the six-row hoeing machine did not fit into this work, but apart from this trouble, which calls attention to the need of standardization in construction, the machine demonstrated its practicability and showed that even the isolating of the plants could be conveniently taken care of.

The second machine was one designed and built by Mrs. de Mesmay, of St. Quentin. It is driven from a single-cylinder motor of 5 to 6 horsepower located above the rear wheels. The front wheels are close together, separated by only a single row of plants. The weight is 900 kilograms and the machine is conducted by one man. The trial showed that the rear wheels of this machine were too narrow, cutting into the soft soil and giving insufficient adhesion where the soil was wet, and, while the operation by one man was considered an important advantage economically, it was observed that the driver could not conveniently regulate the depth at which the hoe blades should work, especially where the surface was uneven. The motor in this machine is, on the other hand, so located that it can be used for all sorts of stationary work on the farm without being dismounted. The third machine was one made by Pruvost-Gandas,

of Aireennes. It works four rows, weighs 800 kilograms and is equipped with a single-cylinder motor of 5 horsepower. As in the Mesmay machine, one man does all the work but is compelled to turn around in his seat to watch the hoe blades, and this may interfere either with the steering of the machine or with the quality of the weeding. It was the opinion of the judges that the construction of the one-man machines might be modified without great mechanical difficulties so as to enable the conductor to watch the penetration of the hoe blades at the same time as the direction of the front wheels.—From the weekly circular of the Syndicate of French Sugar Manufacturers, as republished in *Allgemeine Automobil Zeitung*, No. 34.

CONTRACTIONS AND EXPANSIONS TAKE PLACE IN ARTICLES MADE OF HARDENED STEEL for several years after the articles have been produced and fitted and independently of the changes due to temperature. In measuring instruments and close-fitting parts the changes are sufficient to cause inaccuracies and troubles, and they point to internal tensions whose relief, when it is brought about through the mere lapse of time, may mean a reduction of strength as well. With regard to measuring instruments two methods have been employed for avoiding inaccuracies due to this cause. One consists in hardening only the ends or exposed parts of the instruments, but opinions have been sharply divided on the efficacy of this method. The other, which is of broader application, consists in keeping the hardened article under a heat of 150 to 200 degrees centigrade for some length of time, thereby relieving the internal tension, though with a slight sacrifice of hardness. But no rules for such low-heat annealing have been developed and tested. It was not definitely known if one process of reheating continued for ten hours, for example, was equal to several reheatings of shorter duration but extending over a longer period. A series of experiments were not undertaken at the German government station for the testing of materials. Samples of articles, 10, 25, 50 and 100 millimeters long, were obtained from four different manufacturers (this number responding out of thirty-five firms whose co-operation was solicited) and these were measured at five different times during the period from November, 1906, to December, 1910. The deviations from the normal lengths of the pieces were recorded and tabulated with the use of the Reisenacker measuring machine which allows an expansion of 0.011 millimeter per meter length for each degree centigrade above normal temperature, while the tolerance relating to the accuracy of the measuring operation lies between 0.0002 and 0.003 millimeter. The samples showed remarkable difference. The samples of one firm kept on contracting from time to time, those of another showed mostly expansions; those of a third firm both contractions and expansions. In one case none of the samples gave variations exceeding one-thousandth of a millimeter; in another case the variations ran to five one-thousandths and above. The expansions and contractions were nowise proportionate to the lengths but were reduced where only the ends or exposed parts had been hardened. Many other experiments were conducted with articles made from steels of different composition or which had been subjected to different heat treatment. The upshot of all the experiments, as detailed by the authors, was, however, that in all cases changes in dimensions and shapes could be obviated practically by one reheating at 150 degrees centigrade continued for ten hours. The practice of immersing hardened steel parts in boiling oil for a considerable length of time before regrinding to exact dimensions was thus practically sustained.—A. Leman and A. Werner in *Werkstattstechnik*, August.

ON THE ORGANIZATION OF A CASEHARDENING DEPARTMENT Léon Guillet, the well-known authority, offers the following advice based on his practical experience: The department should be physically divided in two sections, each with its separate personnel, both under one superintendent. The cementation process requires much less precision and ability than the subsequent hardening and, besides, in any factory there are other pieces to be hardened than those which have been cemented. The superintendent should have near him the receiving booth through which all pieces should pass for checking and inspection before treatment. The system of control at this booth forms a separate subject. The cementation department proper should comprise (1) a room for boxing the work, with the necessary tools; (2) adjacent compartments for the manufacture of cementation material, with pestle crusher and reserve stock; for storage of boxes and filler earth; for a little shop to take care of the preparation of sheet metal parts used in the reserve work (copper plating or other means for excluding certain portions of the work from the cementation process) and, in large establishments, for the manufacture of boxes; (3) the furnace room, spacious and ventilated, and (4) a cooling area, which may be a shed, in which the boxes are placed on rails to avoid contact with the ground and moisture. In front of the superintendent's desk, to be consulted by him and by the workman who attends the furnaces, a registering galvanometer should be placed, connected by fixed wires with the pyrometric couple-rod, and, as the latter may be placed in one or the other among the furnaces, there is need of a certain number of wiring posts before the furnaces and before the galvanometer. The latter is also connected with the sight glass which must be movable before the furnace. The wires which connect it with the galvanometer are simply passed along on a cable strung before the battery of furnaces and are not cumbersome in the shop. Datum posts in the ground admit of moving the sight rapidly from one furnace to another. It is well to measure the temperatures every fifteen minutes, and with a battery of six furnaces this operation does not occupy more than five minutes in all, so that the same man can read the temperatures and regulate the furnaces, as is preferable.

In the hardening section the pieces which require no cementation are received direct from the receiving booth at the entrance

to the department, but the hardening section should have a separate booth where the foreman of the hardening room under his own responsibility receives the cemented pieces which he is to harden. At this booth there should be found all the calipers and other tools necessary for verifying the pieces which are delivered to him and seeing whether the cementation alone has not caused some defect, especially if the pieces are not scaly or oxidized. Outside of this receiving booth of its own, the hardening section comprises the battery of furnaces which usually will be of different types; a muffle furnace, salt bath furnaces and even furnaces of different dimensions for large, medium and small pieces. As most cemented pieces must be hardened at 1,000 degrees or at 750 degrees, it is useful to have furnaces of these two temperatures to avoid loss of time.

In front of the furnaces there should be found the battery of baths. There can be a series of movable troughs and of fixed basins. The movable ones are intended for small work and for baths which need not be very cold. They should roll on rails. The fixed basins are best sunk into the ground so that their rims are just flush with it and are intended for large pieces and for cooling by forced circulation of water. A hardening shop should have a large water bath, a smaller water bath, an oil bath (the preferred composition of the oil is, two parts of rapeseed oil, two parts of nut oil and one part of olive oil) and one bath more active than oil and less active than water, such as lime water.

To measure temperatures in the baths, thermo-electric couples with indicating or recording galvanometer are preferred. If one wants greater precision, an electric-resistance apparatus may be used, but the recording instrument based on this principle is very delicate and should not be considered an industrial tool.

The hardened pieces should be checked off and returned to a checking bureau situated near the superintendent, where they are recognized as good or bad. In the first case they are passed to the mechanical shops; in the second they are returned to the hardening room, and if suitable treatment continues to give a poor showing at the checking roof, the quality of the original material should be again verified.

With this equipment the cost of work should not be excessive. Night work, however, always gives poor results unless there is a complete double shift of workmen, including two superintendents.—*Le Génie Civil*, July 29.

## Calendar of Coming Events

### Shows, Meetings, Etc.

- Sept. 25-30.....Atlantic City, N. J., Convention and Exhibition of the Carriage Builders' National Association.
- Oct. 7-14.....Chicago, Ill., Show of Chicago Automobile Trade Association.
- Jan. 1-5, 1912.....New York City, Grand Central Palace, Annual Show, Automobile Manufacturers' Association of America.
- Jan. 6-13.....New York City, Madison Square Garden, Twelfth Annual Show, Pleasure Car Division, Automobile Board of Trade.
- Jan. 6-20.....New York City, Madison Square Garden, Annual Show, Motor and Accessory Manufacturers.
- Jan. 10-17.....New York City, Grand Central Palace, Twelfth Annual Show, National Association of Automobile Manufacturers; also Motor and Accessory Manufacturers.
- Jan. 15-20.....New York City, Madison Square Garden, Twelfth Annual Show, Commercial Division, Automobile Board of Trade.
- Jan. 18-20.....New York City, Annual Meeting of the Society of Automobile Engineers.
- Jan. 27-Feb. 10....Chicago Coliseum, Eleventh Annual Automobile Show under the auspices of the National Association of Automobile Manufacturers. Pleasure cars, first week. Commercial vehicles, second week. Accessories, both weeks.
- March 2-9.....Boston, Mass., Tenth Annual Show, Boston Automobile Dealers' Association, Inc.

### Race Meets, Runs, Hill-Climbs, Etc.

- Sept. 30.....Guttenberg, N. J., Track Races.
- Sept. 30.....Bridgeton, N. J., Track Races, South Jersey Motor Club.
- Sept. 30.....Flint, Mich., Track Races.
- Oct. 7.....Danbury, Conn., Track Races, Danbury Agric. Soc.
- Oct. 7.....Philadelphia, Fairmount Park Road Races, Quaker City Motor Club.

- Oct. 7.....Springfield, Ill., Track Races, Springfield Automobile Club.
- Oct. 9-13.....Denver, Colo., Reliability Run, Denver Motor Club.
- Oct. 10.....Bedford, Ind., Hill Climb.
- Oct. 11.....Oklahoma City, Okla., Reliability Run, Oklahoma State Automobile Association.
- Oct. 12-13.....Peoria, Ill., Track Races, Peoria National Implement and Vehicle Show.
- Oct. 14.....Santa Monica, Cal., Road Races.
- Oct. 14 (to 25)....New York City, Start of the Annual Glidden Tour, en route for Jacksonville, Fla.
- Oct. 16-18.....Harrisburg, Pa., Reliability Run, Motor Club of Harrisburg.
- Oct. 21.....Atlanta, Ga., Track Races.
- Oct. 27-Nov. 3....Chicago, Ill., Thousand-Mile Reliability Run, Chicago Motor Club.
- Oct. 31.....Shreveport, La., Track Races, Shreveport Automobile Club.
- Nov. 1.....Waco, Tex., Track Races, Waco Auto Club.
- Nov. 2-4.....Philadelphia, Reliability Run, Quaker City Motor Club.
- Nov. 3-4.....Columbia, S. C., Track Races, Automobile Club of Columbia.
- Nov. 4-6.....Los Angeles-Phoenix Road Race, Maricopa Auto Club.
- Nov. 9.....Phoenix, Ariz., Track Races, Maricopa Automobile Club.
- Nov. 9, 10, 12....San Antonio, Tex., Track Races, San Antonio Auto Club.
- Nov. 27.....Savannah, Ga., Vanderbilt Cup Race, Savannah Automobile Club.
- Nov. 30.....Los Angeles, Cal., Track Races, Motordrome.
- Nov. 30.....Savannah, Ga., Grand Prize Race, Savannah Automobile Club.
- Dec. 25-26.....Los Angeles, Cal., Track Races, Motordrome.

### Foreign Fixtures

- Oct. 1.....Gaillon, France, Hill-Climb.
- Oct. 12-22.....Berlin, International Automobile Exhibition.
- Nov. 3-11.....London, Eng., Olympia Show.

# THE AUTOMOBILE

Vol. XXV

Thursday, September 28, 1911

No. 13

## THE CLASS JOURNAL COMPANY

H. M. SWETLAND, President

CONDE NAST, Vice-President and General Manager

R. M. COREY, Secretary and Treasurer

231-241 West 39th Street, New York City

Cable Address - - - - - Autoland, New York  
 Long Distance Telephone - - - - - 2046 Bryant, New York

### SUBSCRIPTION RATES

United States and Mexico - - - - - One Year, \$3.00  
 Other Countries in Postal Union, including Canada - - - - - One Year, 5.00  
 To Subscribers—Do not send money by ordinary mail. Remit by Draft,  
 Post-Office or Express Money Order, or Register your letter.

Entered at New York, N. Y., as second-class matter.  
 The Automobile is a consolidation of The Automobile (monthly) and the Motor  
 Review (weekly), May, 1902, Dealer and Repairman (monthly), October, 1903,  
 and the Automobile Magazine (monthly), July, 1907.

## The Will and the Way

TWO years ago one maker refused to build fore-door bodies because he did not know how to ventilate them. He said they could not be satisfactorily ventilated and that consequently they would never come into favor. After he saw the error of his ways and realized that he would become a back number if he did not discard some of his old bodies and build fore-door types, he tried to start a criticism against those who advocated the fore-door body on the ground that they were injuring the industry by compelling many makers to build over bodies that were antiquated. This is a deplorable case of being behind the times. When a maker is so slow that he is caught with a line of old-fashioned goods on his hands he should have enough pride to suffer his loss and use every effort to get into the van. A maker who is so busy that he cannot follow the trend of public demand closer than this should take a holiday every week and get out among the public, keep his ears and eyes wide open and find out what is doing. It is just as important to know the public pulse as it is to have a good designer.

But makers of automobiles must get out into the buying world for other reasons than studying the body requirements. They can find out very well just where their cars are weak and what the public thinks of them. In the early days many makers personally went on the long reliability runs, attended the hill-climbs and visited the races with the sole object of studying the performances of their own cars as well as those of other cars. Of late there has been a falling off in this respect. Many makers who have built up reputations on their achievements in contests are now more or less content to rest on their laurels. While they have been resting the young bloods of the industry have been toiling upward in the night. The younger element has adopted the latest designs, and now the older heads are compelled to fall in line. The automobile maker who imagines that his car is perfected, that it will sell in its present form for two, three or perhaps four seasons yet to come, is making an error. He will

be rudely wakened some day with a lot of unsold cars on his hands. That maker does not exist to-day who can safely sit down and say, "Our car is perfected; we have nothing to do but manufacture and fill orders." The public is getting wiser every day in the matter of automobiles; and reputation, while it will dispose of the factory output for a season or so, is not enough to bank upon for the future. As one season succeeds another, fresh examples are given of old houses losing their hold. The only rule is to keep everlastingly at it. Keeping to the front to-day demands unity in every department; it demands keeping in touch with the latest constructions in every respect, and it demands following the public sentiment.

\* \* \*

## Studying Salesmanship

THESE are the real testing days. A year or so ago the salesman was more or less of an order clerk. He used to busy himself writing out orders. The sales manager was a distribution chief. His big job was to satisfy dealers everywhere that they were getting their correct allotments of cars at the specified times, and that one was not being given an undue lot of automobiles at the expense of some other one. Those days are over. To-day the salesman has to sell cars. Many of the old salesroom decorations are missing. They made good when people bought cars, but could not stand the pace when the rule became one of the salesman selling machines.

But the salesman is not the only selling factor in a salesroom. The salesroom itself is a quantity to be reckoned with. The most successful merchants employ high-paid decorators to display their wares. This display feature of automobile salesmanship has scarcely been scratched. How many salesrooms can you find in which the laws of display have been studied out to the smallest detail? There are a few of such in every big city, but they can generally be counted on the fingers of one hand. Above all, the salesroom should be well lighted, it should be orderly, it should be clean, and the salesmen should be in keeping with the situation. The public of to-day is a critical public; it is accustomed to the finest arts of salesmanship in such fields as insurance, bonds, stocks, real estate, debentures, etc., and when the amateur automobile salesman tries to create an impression it frequently resents it. It does not remonstrate, but simply does not buy.

One of the largest automobile concerns in the country has realized that not only must its salesmen know its own cars, but they must know all about the car of its leading competitor. At one of its conventions a car of its leading rival was purchased and analyzed in every detail. The salesman thus became acquainted with its good qualities as well as with its defects. In this way he became better qualified to meet the arguments of the buyer. Nothing is quite so convincing as an array of facts when it comes to making a sale. The more the salesman knows about the other car, the more confidence he has in himself, the more convincing are his statements, and the more weight they have with the buyer. Knowledge is not the only essential, but it is a big factor. In addition to knowledge the salesman must know how to address people; he must have ability in studying his buyer; he must know the logic of arguments; he must have address, and must know his car thoroughly.



## Knight a Guest of His Associates

**C**HARLES Y. KNIGHT, inventor of the Knight sleeve-valve motor, was the guest of honor at a dinner given Monday night at the New York Athletic Club. There were about 100 present, including representatives of the four licensees in the United States under the Knight patent and a representative gathering of automobile officials. Mr. Knight arrived in New York on the *Campania* last Saturday and will remain in this country only a short time. He is booked up for a number of addresses and lectures in various parts of the country and his itinerary as marked out so far will extend to Pittsburgh and Cleveland and may extent still further west.

During the speeches that followed the elaborate dinner the hitherto unwritten history of the invention was outlined by Mr. Knight and Messrs. Lonas and Kilbourne, who were associated with the inventor in developing the device and placing it upon the market.

Mr. Knight told the story of his life in simple, direct fashion. He said he was born in Indiana and entered the battle for a living as a printer. He progressed through the whole range of the craft and at the end of 25 years was editor of a weekly produce paper in Chicago. During his service in the publishing line he invented a newspaper printing press and a wrapping device, neither of which gained him much fame, and he experienced two rather discouraging collisions with competitors who infringed patent rights he thought he was entitled to.

At the time of the commencement of the vogue of the automobile Mr. Knight

became interested in the new art and purchased one of the earliest examples of the industry that was shipped to Chicago.

In the fall of 1907, having gained the ear of the Daimler Company, in England, the motor was accepted by that concern and within the next year was placed with representative concerns in other European countries.

With regard to its introduction in the United States, Mr. Knight recounted his experience with four prominent automobile manufacturers. He said he had arranged for licensing the four, when a reissued patent covering steam engines was injected into the situation and two of the companies, having gained certain interests in the reissued patent, which Mr. Knight said was written with a model of his engine as its foundation, declined to

proceed under the license and threatened Mr. Knight with action in infringement if he attempted to manufacture his own engine in the United States.

This proved effective in stopping the disaffected pair of manufacturing concerns from taking up the device at the time and served as a check upon the activities of the Knight motor in America until this year.

Mr. Knight said that Mr. Kilbourne, his partner and financial backer, had spent \$150,000 before there was any substantial return from the business.

Mr. Lonas acted as the attorney for Mr. Knight during his early struggles and was instrumental in paving the way for the first real trial of the motor at the hands of the Daimler company.

One of the most interesting



Charles Y. Knight, inventor of the Knight sleeve-valve motor



Charles Y. Knight was honored by his associates at a banquet held at the New York Athletic Club on Monday evening, Sept. 26

features of the speaking was the attitude assumed by the American licensees. Horace De Lisser, vice-president of the United States Motor Company, said that about 40 per cent. of the number of cars authorized under the licenses granted to the Columbia and Stoddard-Dayton companies had been contracted for and the Columbia company desired to make 100 per cent. more than its allotted number and the Stoddard-Dayton, 75 per cent. more, for 1912 business.

C. E. Hadley, production manager of the Knight engine department of the Stearns company, said that the engine after a series of exhaustive tests had proven satisfactory and that 40 cars had been finished.

Mr. De Lisser created something of a sensation when he spoke of the part that is to be played in the making of Knight engines in the United States by the Atlas Engine Works, of Indianapolis. He said that, while he had no doubt as to the quality of work to be turned out by the engine company, he wished to warn Mr. Knight that there is real danger to be feared if the engines so made should get into the hands of automobile manufacturers who do not realize that there is anything else in an automobile beside the engine.

He said that, in such an event, it might reflect upon the licensees who manufactured their own Knight engines.

Replying broadly to Mr. De Lisser, H. J. Halle, treasurer of the Atlas Engine Works, assured the licensees that their interests would be jealously guarded by his company and that every precaution would be taken to prevent the engines made by his concern from getting into undeserving hands.

He explained that the Atlas Engine Works had secured the fourth American license from Mr. Knight and that the company would make all the Knight engines in the United States that were not made by the other licensees. He broadly intimated that the activities of his company might not be permanently limited to such work, but that, if in the future the licensees wished the Atlas company to make their engines, the company would undertake to supply the whole licensed automobile trade in the United States.

Other speakers were: J. G. Sterling, of the Stearns engineering department, Frederick E. Dayton, of the Columbia, and others. J. E. G. Ryan acted as toastmaster. Those present included the following:

Charles Y. Knight, L. B. Kilbourne, Frank E. Lonas, H. W. Nuckols, Horace De Lisser, Alfred Reeves, Henry Sanderson, F. H. Baker, H. H. Hower, W. A. Lesser, C. E. Hadley, J. G. Sterling, E. G. Moore, Andre Massanet, E. Lilly, James M. Carples, Coker F. Clarkson and many others.

### Knight Explains His Engine

In the presence of a gathering numbering close to 400 automobile experts, Charles Y. Knight explained in exhaustive style the operation of the Knight Sleeve-Valve Motor at the Automobile Club of America, Tuesday evening.

For over an hour the assembly listened with profound attention to the inventor's address and at the end, the speaker was questioned on a number of points and devoted another hour to answering the queries.

Mr. Knight was introduced by Emerson Brooks. He began his address by outlining the preliminaries that led up to the adoption of the motor by several foreign companies and its introduction into the United States, laying particular stress upon the action of the Atlas Engine Works, which he said had abandoned the making of steam engines, after 50 years of successful operation along that line, to take up the manufacture of the Knight engine.

He said that the conclusions to be drawn from this action are that this company believes that the reciprocating engine of the future will be of the internal combustion type and that the ultimate internal combustion motor will not be of the poppet-valve variety.

In describing the present state of the art insofar as internal

combustion engines are concerned, Mr. Knight said that the field is divided into two parts; one the poppet-valve school and the other the four-cycle sleeve-valve motor. He minimized the importance of the two-cycle engine for automobiles, saying that that principle had been employed with success in one instance, but that the public was not enthusiastic. He stated that public taste was difficult to follow, but that it was a most important influence.

In emphasizing the effect that the introduction of the sleeve type has had upon the art he said that at least 250 patents have been issued abroad covering suggestions for improvement of the sleeve-valve engine, none of which varies materially from the Knight device.

In telling of the salient features of his invention, Mr. Knight said:

"The outstanding feature is the substitution of sleeve valves for poppet valves, which idea I believe was wholly original with myself. Other forms of valves than mine, instead of contributing to further efficiency of the motor, are employed in spite of their disadvantages.

"The ports in the inner sleeve are sealed in operation through the lapping of their openings with a wide ring, called the junk ring. This ring is similar in construction to the ordinary piston ring, only wider in order to seal the ports. Under the junk ring is placed a second to insure perfect contact with the interior of the sleeve. Above them are two or three ordinary piston rings to bar the escape of gases which might pass the break in the junk ring.

"At the time of explosion the ports in the inner sleeve are central with a wide junk ring. Hence at the time of the development of the greatest heat, the ports are not exposed to heat at all and therefore the lips and the section of the sleeve carrying them are cooled after every explosion, being pushed up and rubbed against a water-cooled surface."

Mr. Knight pointed out that in the case of poppet valves, the heads are always subjected to the highest temperature generated in the explosion chamber, which he said at the maximum was approximately the melting point of steel.

He then described in much detail the system of lubrication used, dealing with the difficulties encountered in this phase of the operation of all motors and stating that in the Knight engine the problem had been solved in a satisfactory manner. He brought out the fact that only on the compression stroke was their heavy pressure on the sleeves and that in consequence of the relaxed pressure on the other three strokes, the flow of oil over the lubricated surfaces of the sleeves and cylinder was comparatively easy to accomplish. This he said was by splash at the bottom and by capillary attraction at the top.

The clearance between the sleeves, he said, may be as great as that between the piston and the cylinder walls.

Referring to the subject of wear in the sleeves, Mr. Knight said that it was inappreciable and that in motors that had traveled 100,000 miles no evidence of wear was to be found after the first few hundred miles. He said that he was confident that they would not deteriorate from the use represented by 1,000,000 miles on the road.

He made a special point about the accessibility of the sleeves for cleaning or the removal of carbon deposits. The power lost in driving the eccentrics which actuate the sleeves, he said, he found to be about 2 horsepower in a motor developing 77 horsepower and using a dozen 5-inch sleeves and reckoned that the proportion of loss as compared with poppet-valve engines of similar size would be about 160 to 250, or in other words, 50 per cent. greater than it was in the sleeve type.

He then recounted the tests to which his engine had been subjected, going into the subject in much detail.

Mr. Knight used a huge working model of a sectional cylinder, showing the piston and sleeve action, eccentrics and shaft and the functioning of the ports.

The questions asked at the conclusion of his address did not bring out anything radical or particularly interesting.

## S. A. E. Tour Abroad

**P**ROSPECTS are good for the size and success of the trip the members of the Society of Automobile Engineers will take abroad during November, to view the Automobile Show at Olympia, London, and leading automobile factories in England and France, and to participate in meetings with the Incorporated Institution of Automobile Engineers. November 11 the British Society of Automobile Engineers will give the S. A. E. visiting members a dinner, and November 8 there will be a joint technical meeting, at which a member of the society will present a paper.

In addition to events previously announced, visits will probably be made to the South Kensington Museum in London, the testing laboratories of the Royal Automobile Club of England and of the Automobile Club of France, the Conservatoire des Arts et Métiers, and the Clement and DeDion plants in France. Factories making commercial vehicles as well as pleasure cars will be visited; also those having moderate-priced as well as highest-priced product.

The party will probably sail on a steamer leaving New York November 1, and the program outlined will take up practically the whole month of November, including the return journey home.

The following have signified their intention of making the trip; many of them will be accompanied by their wives: Henry Souther, president of the society; Howard E. Coffin, past president of the society; D. G. McDiarmid, superintendent and designer, C. P. Kimball & Co., Chicago; William E. Metzger, secretary and treasurer, Metzger Motor Car Co.; William Kelley, vice-president and engineer, Metzger Motor Car Co.; J. G. Vincent, chief engineer, Hudson Motor Car Co.; A. R. Miller, Bartal, Daly & Miller; John S. Clarke, vice-president, Autocar Co.; B. B. Bachman, engineer, The Autocar Co.; David S. Ludlum, president, Autocar Co.; G. R. Wadsworth, assistant to president, Peerless Motor Car Co.; A. J. Myers, engineer, G. & A. Carbureter Co.; G. B. Von Rottweiler, manager and chief engineer, Falls Machine Co.; H. L. Davisson, engineer, Edison Storage Battery Co.; L. C. Marburg, secretary and treasurer, Marburg Bros.; Coker F. Clarkson, secretary, Society of Automobile Engineers.

Quite a number of additional members will join the party if they can make the necessary arrangements.

Membership in the Society of Automobile Engineers is still growing steadily and rapidly, the present figures for all classes being 934, of which about 700 constitute the full active roster. The growth of the S. A. E. has been phenomenal. Less than 18 months ago it had no more than 300 members on its membership rolls.

This growth is particularly accountable to three factors: First, the absorption of the mechanical branch of the A. L. A. M., which nearly doubled its membership; second, the rapid growth of the automobile industry; third, the active, useful work of the society itself.

The field from which it has drawn its members is limited, but the scope from which it may rightfully draw them is constantly increasing. There are probably 1000 fully qualified engineers employed by the manufacturers of cars. There are at least another 1000 employed by manufacturers of automobile accessories and quite as many independent engineers of high attainments who act in a consulting capacity for both car and accessory makers.

In addition to these men, all of whom possess a highly technical training, there are many thousands of corporation officers, students of mechanics and men of practical knowledge connected with the industry who are eligible, to consideration in the limited grades of the S. A. E. Naturally enough the society is thriving from a membership point of view, just as the industry it represents is growing in importance, not only as a factor in the progress of the day, but also as a potent force in the general advancement of civilization.

## Gossip of Coming Shows

**D**URING the past week slow progress has been made with reference to the two big automobile shows to be held in January. With regard to the space allotments at Madison Square Garden during the exhibit of pleasure cars, the probabilities are that there will be only a few minor changes, but in the truck section the Automobile Board of Trade is in a quandary.

The management is endeavoring to locate the various exhibits approximately as they were staged last year but owing to the pronounced tendency of many of the companies to make larger trucks than before the problem of housing exhibits above the main floor is proving a puzzle.

The difficulty lies in the inability of the elevators to handle the largest types of trucks. Thus, where a concern that formerly showed small cars in the gallery, and this year wishes to display big ones, something will have to be done to make it possible.

The National show, scheduled for the Palace, is making good progress. Already contracts have been made to display the Regal, Waverley, Imperial, Stutz, Abbott, Cole, Crow, Firestone-Columbus, Elkhart, Colby, Great Western and Rambler among the pleasure automobiles and the Sanford-Herbert, Cortland, Federal, Lippard-Stewart and Universal, among the commercials. In addition to these, contracts have been practically closed with the Kissel, Schacht, Lion, Hupmobile, Clark-Carter, Paige-Detroit, and the Hupp Corporation. There will be a fine exhibit of electrics including Baker, Babcock, Rauch & Lang and Detroit.

It is announced that fully forty makes of pleasure cars are likely to be shown and probably twenty different types of trucks.

## Straightening Out Halladay Tangle

CHICAGO, ILL., Sept. 26.—Last Saturday a petition in voluntary bankruptcy was filed by the Streator Motor Car Company, of Streator, Ill., and also John C. Barlow and Paul Chubbuck, the principal owners of the company. About 2 hours later one of the creditors of the company presented a petition for the appointment of a receiver and the Central Trust Company was appointed by Judge Landis.

Yesterday the Streator Motor Car Company, in a petition, joined in by its principal creditors, asked that the order appointed by the receivers be vacated, and the matter was continued until to-day. Judge Landis, after hearing the case, decided to remove the receiver.

It developed during the hearing to-day that the Streator Motor Car Company had been doing a large business on a small capital and was very hard pressed. Mr. Barlow and Mr. Chubbuck, its chief stockholders, owned large real estate holdings in and around Streator but could not quickly realize on the property, so as to assist the company.

In this condition they approached the larger creditors of the motor company with a proposition to bond their real estate holdings for \$425,000 and give the bonds to the creditors of the company in payment of its debts, this putting the company on its feet financially. About 80 per cent. of the creditors in number and amount accepted, but a small minority was trying to block the proposed settlement and the result was the filing of the petitions in bankruptcy.

It was the first case presented in this jurisdiction under the amendment of the bankruptcy act in 1910. The petitioners did not ask to be adjudged bankrupt, but simply that a meeting of their creditors be called to prove up their claims and that at such meeting, they proposed to submit to the creditors the proposition of accepting the bonds in payment of their claims against the motor company, under the amendment referred to.

It is understood that a meeting of the creditors will be called in about 10 days. While no formal statement has been made, it is claimed that the Streator Motor Car Company has assets of about \$750,000 and owes some \$300,000. The proposed plan will put the company entirely out of debt. In the meantime it will operate as heretofore.



Flathead Motor Club celebrates completion of a section of the Glacier Park-Yellowstone Park road with a delightful tour

## Montana Building Inter-Park Road

**K**ALISPELL, MONT., Sept. 22—Good roads do not necessarily follow in the path of settlement and territorial development, but may be the forerunner of the upbuilding and populating of a hitherto inactive area. This has been demonstrated by Flathead County, Montana, which, a few days ago, celebrated the opening of a 30-mile automobile boulevard where a few months ago had been only a rough Indian trail through the forest. This road, when completed, is destined to bind Yellowstone Park and the Glacier National Park, 300 miles apart as the crow flies.

In honor of the opening of Flathead County's section of the road a band of motorists from Kalispell, Mont., with 50 cars in line, toured from their town to the Glacier National Park for inspection of the new highway.

The start was made under the cloudless skies of a perfect September day, with just a tang of approaching autumn in the air. The run was planned by the Flathead Motor Club to celebrate the completion of the road across that county.

M. W. Bottorf, in a 48-horsepower Franklin, was pace-maker. Falling in behind him the automobiles wound through a valley road to Columbia Falls, and a few miles out of town many had their first introduction to the great improvement made within the past year. Stumps had been removed, curves cut out and the roadbed graded and rolled.

From Columbia Falls the way led across a bridge over the Flathead River, and at the top of the hill the cars stopped in a long line which extended back through the valley between tall and stately pines.

Through picturesque Red Rock Canyon, with the blue Flathead River at the left and at the right a precipitous mountain, where a couple of years ago the old passage was by foot or horseback, the procession wound round on a shelf cut out of the mountain side. It was nearly all new country, except as it had been seen from passing railway trains. The trees stand thick and straight on either side, 100 feet high, and in places the road is a great gash through the forest.

The transformed "tote road" led on, with varying scenery, to Lake Belton, where some of the travelers stopped for lunch, the others traveling three miles farther to Lake McDonald.

The building of this highway may be an important argument for the admission of automobiles to Yellowstone Park, where they are now forbidden by the Government.

The building of the Flathead County part of the road was considerably criticized by those who failed to see the object in building a road through a rough forest country. Other sentiments, however, prevailed and the construction was pushed rapidly forward with the result that Flathead County, Montana, is now a much-talked-of section of the Northwest, while it has, by this highway, opened its towns and its territory to the travel of motorists of the whole United States.

### Good Roads Convention November 20-23

RICHMOND, VA., Sept. 25—The National Good Roads Convention which will be held in this city on November 20-23 and which President Taft has given assurance he will attend, will be extensively advertised throughout all the States through the Washington office of the association.

The most important matter to be taken up at the convention will be the construction of the national highway between Richmond and Washington as a memorial to President Lincoln at a cost of \$2,000,000.

Various plans for the "capitol to capitol" route have been suggested. Charles P. Light, chief field representative, is in Richmond making the final preparations for the national convention.

### Government Instructs in Road Examination

WASHINGTON, D. C., Sept. 25—Dust prevention and road preservation are almost inseparable subjects in the study of good roads, so insistently demanding the attention of road engineers

and chemists interested in modern road construction. The bulletin just issued by the Office of Public Roads, Department of Agriculture, on methods for the examination of bituminous road materials, containing complete descriptions of the methods of examination for that class of materials, as employed at present by that branch of the Government service, will undoubtedly materially further the adoption of standard methods, a matter of the utmost importance at this time, different methods frequently obtaining in the same State.

These methods are presented in such a form that any intelligent person may, with a little practice and the proper equipment, make such examination. It is to be regretted that no standard methods for examining bituminous road materials have been generally adopted, as the necessity for such standards has become imperative. The Office of Public Roads has given considerable attention to the matter.

### Maryland Seeks to Amend License Law

BALTIMORE, Md., Sept. 25—A resolution was introduced into the City Council by Councilman Garland which directed that the joint special committee on legislation of the two branches of the Council during the next session of the Maryland Legislature be empowered to draft amendments to the motor vehicle law regarding the issuing of licenses.

These proposed amendments call for the appointment of a reliable board of examiners to whom all applicants for licenses to operate motor cars shall submit their claims and qualifications.

Councilman Garland's aim is to have licenses withheld from all persons except those who, in addition to possessing the proper skill, are sufficiently cautious in their habits and not a menace to the general public. Furthermore, Mr. Garland desires to have a provision inserted making it punishable for any one to operate a motor car unless he is an actual licensee in his own name; also that the city of Baltimore shall receive a volume of revenue from automobile licenses in exact proportion to the number of automobile licenses granted to residents of the city.

### Service Cars at Municipal Congress

CHICAGO, Sept. 25—Motor cars are in evidence in the Coliseum this week during the International municipal congress and exposition now in progress here. More than half of the public service vehicles on display are motor driven. Among the exhibitors are the Briggs Labor Saving Specialty Co., the Kelly-Springfield Road Roller Co. and several makers of motor fire-fighting equipment.

## Good Roads, Keynote of Prosperity

(Continued from page 519.)

The cost of some of the best present work runs as high as \$16,000 a mile and the average of first-class road making is probably in the neighborhood of \$10,000. If general highway construction all over the country were to reach such figures the total expenditure would be considered prohibitive. But while general improvement on any such basis is still a long way in the future, it will arrive one day and the United States will wonder why there ever should have been a doubt about the wisdom of a permanent investment of ten billions of dollars in country highways.

It will not come in any one year and will not be completed in any one decade; thus the expenditure will be spread over many years and the returns will be so quick to follow investment in any locality that the stupendous amount of money involved will not prove burdensome. The investment of vast sums of money in road improvements will not serve to divert the wealth of the country from the ordinary channels of trade, for, while the highway bonds will undoubtedly attract conservative investors, the proceeds of the bonds will be spent for labor and material and in the course of ordinary business will be immediately drawn back into the commercial veins and distributed to the arteries of the business body.

There is no chance to overstate the importance of good roads. There never was a safer and better investment for the taxpayers of any township, county or State than the fully justified reputation for having excellent highways. It means more trade and better trade; more health and human enjoyment; more social pleasure and business facility. It means in a word, to the general citizenship, a life worth living.

### Maxwell Scores in Lu Lu's Run

PHILADELPHIA, Sept. 25—Eighty-six contestants appeared for the first social run of the Lu Lu Temple Automobile Club from Philadelphia to Atlantic City last Saturday, making one of the largest organized tours ever held in the East.

Four prizes were awarded to the contestants who arrived in Atlantic City nearest to the secret time schedule set by Potentates W. Freeland Kendrick and Harry Evans. The winner proved to be a new Maxwell Special entered and driven by William A. Walton. A Maxwell Messenger 16-horsepower runabout, driven by A. A. Jones, won fourth place. At the end of the run an automobile show was held on the Million Dollar Pier which was attended by thousands.



A great gash cut in the primeval forest to accommodate the road from Glacier National Park to Yellowstone Park.



# Late News from the Contest World

**H**ARTFORD, CONN., Sept. 29—A bursting tire robbed Ralph DePalma's Simplex of an opportunity to snatch the 15-mile circular track record at Charter Oak Park yesterday afternoon. Taking the turn at the eighth-mile post at a mile-a-minute gait, the tire burst and the car skidded to within a foot of the fence.

The trial was the climax of the race meet held under the direction of the Automobile Club of Hartford before a crowd of 5,000 people. The DePalma-Simplex combination was the chief attraction. He went after the one-mile record and failed, covering the distance in 521.5 seconds, the record being 513.5 seconds. Later he went after the Charter Oak Park record for five miles and succeeded, his time being 4 minutes and 23 seconds, 12.5 seconds faster than the record.

There was a special race between three Motorettes, the three-wheeled car built in Hartford. It was intended to make it a five-mile affair, but after one mile had been completed it was announced that another would finish it. The winning car covered the two miles in 5:14.2-5. DePalma then brought out his Simplex to go after the five-mile record, and he won.

The event for non-stock cars, Class C, Division 3 C, 231-300 cubic inches, for five miles was won by DePalma, driving a Mercer, in 5:19.1-5; Brainard, in a Cole 30, getting second place, and Beach in a Mercer third. DePalma won first in a five-mile free-for-all in a Mercer, with Brainard second and Beach third.

A parade of 1912 cars and various gymkhana events completed the program. The summaries:

Record Trial, 1 Mile—(Record, 0:51.3-5)			
Position.	Car	Driver	Time
	Simplex	DePalma	0:52.20
Record Trial, 5 Miles—(Record, 4:24.2-5)			
	Simplex	DePalma	4:23
Non-Stock, Class C, 231-300 Cubic Inches			
1.	Mercer	DePalma	5:19.20
2.	Cole "30"	Brainard	5:44.80
3.	Mercer	Beach	5:54
Non-Stock, Class D, Free-for-All, 5 Miles			
1.	Mercer	DePalma	5:14
2.	Cole "30"	Brainard	5:33
3.	Mercer	Beach	5:40
15-Mile World's Record Trial			
	Simplex	DePalma	Unfinished

## Lee Oldfield Held Without Bail

SYRACUSE, N. Y., Sept. 23.—Lee Oldfield, whose racing machine crashed into the crowd at the State Fair grounds last Saturday and killed 11 persons, appeared before Coroner George R. Kinne yesterday to testify to conditions leading to the accident. Though for several days his nerves were totally unstrung, and at one time the hospital attendants feared for his reason, he was much improved yesterday, though much affected while giving testimony. At the inquest Oldfield gave his age as 22, his residence as Wilkes-Barre, Pa., and stated that he was married and had an infant daughter. The driver placed two licenses in evidence to show that he was considered competent to pilot a car. The tire that burst and caused the accident was thoroughly examined, there being a gash of almost a foot in the shoe and a rent of about equal length in the inner tube. Oldfield admitted it was worse than he realized, but said that such a condition might exist on the inside and yet have the outer tire apparently sound.

In regard to the moot question of whether Oldfield was signaled to hit up speed, he said his manager, Mr. Moross, signaled him to that effect after completing his thirty-ninth mile. Till

then he had been shutting off his power right after leaving the grand stand, to make the turn in safety on the mile course; but after getting the signal he went as far as the bend without shutting off the power. He testified that the tire that burst was the one that was getting the most strain, being the first to hit the embankment on the cut across.

Bail was refused for Oldfield, he being under technical arrest. The inquest will be continued and is certain to be exhaustive. Meanwhile, Oldfield is under the surveillance of a plain clothes man while at the hospital. He expects in a day or two to remove to a hotel.

## Preparing for Fairmount Park Race

PHILADELPHIA, Sept. 23—Active preparations are under way by the Quaker City Motor Club for the fourth annual Fairmount Park road race to be held on Saturday, October 7. Steam rollers, watering carts and a gang of men are at work daily getting the course in ship shape, and in order to have the roadway in as perfect condition as possible, there will be no letup in the work by the organization until the day of the race.

As was the case last year, the proceeds from the sale of seats and parking places will be donated to various charitable organizations.

The entries at present time are: Lozier, to be driven by Ralph Mulford, runner-up last year; Len Zengle, who won the event last year with a Chadwick, will drive a National in the coming race; National, Donald Herr; Fiat, Lee Oldfield; Casc, Joe Jagersberger, and Stutz, G. Anderson.

## Glidden Tour Has 61 Entries

There are now 61 entries filed for the Glidden Tour. Those entering during the past week are as follows: L. C. Brown, Athens, Ga., Mitchell; P. D. Sandlin, Jasper, Fla., Cadillac; Bishop and Varner, Athens, Maxwell; J. J. Howard, Jacksonville, White; L. C. Denmark, Jacksonville, Cadillac; R. S. King, Arcadia, Fla., Cadillac; Carolina Portland Cement Company, Atlanta, Ford; E. M. Willingham, Atlanta, Ford; J. O. Teasley, Alpharetta, Ga., Ford; C. A. McCardle, Indianapolis, E-M-F; and Athens Motor Company, Athens, Columbia.

## Coming Contests on Track and Road

NEW YORK CITY—What may prove to be the last track races to be seen in the Metropolitan district this season will be staged at Guttenberg, N. J., on Saturday afternoon. The card contains 4 dashes at five miles and 2 at ten miles for non-stock cars. Second money is offered in all the events.

OMAHA, NEB., Sept. 25—The Omaha Speedway Association will pull off a series of four days' racing on next Saturday, September 30, Sunday, Monday and Wednesday. Men have been at work on the track improving it and building better fences, but this will all be completed before Saturday. There will be a 50-mile event each day, with shorter races. The Ak-Sar-Ben festivities will bring large crowds into the city.

SAN FRANCISCO, Sept. 23—An international automobile race in Golden Gate Park, in this city, on Washington's birthday, February 22, next year, is the plan of the publicity committee of the Panama-Pacific International Exposition Company.

OKLAHOMA CITY, OKLA., Sept. 23—The 800-mile route of the *Daily Oklahoman* reliability run of 1911 will start on October 12. The entries will include not less than sixty cars.

## Trade and General News High Lights

**D**ETROIT, MICH., Sept. 25—In reply to the injunction bill filed by the Hupp Motor Car Co., R. C. Hupp, of the Hupp Corporation, maker of the new R. C. H. car, made the following statement:

"In view of the pleasant relations which have always existed between the Hupp Motor Car Co. and myself, I am very much surprised, indeed, to hear of this action. They have known for several months of my intention to place upon the market a new gasoline car, to be handled by the Hupp Corporation.

"In the naming of the new car, I was careful to avoid choosing a name that would conflict in any way or tend to injure the business of the Hupp Motor Car Co., and, although the name 'R. C. H.' is my own initials, it does not seem to me there is anything in the name of the new car to which to take exception.

"As for the Hupp Corporation, it is a combination of five large automobile parts plants, organized several months ago, consisting of a large foundry, drop forgings plant, machine shops, electric and gasoline car assembly plants. For nearly a year we have been engaged in the manufacture of automobile parts and in the building of electric and gasoline cars, including the Hupmobile, and in all that time there has never been a word of objection from anyone to the use of the name 'Hupp' in connection with our business. All the castings and forgings and machine parts in the Hupmobile are made, and the final assembly and shipping of this car is done at this plant.

"We have one of the most completely equipped automobile factories in the world, with a capacity of 60 cars a day, and, with the additions contemplated, we will increase this capacity by nearly 50 per cent.

"The Hupp Corporation was named for my brother, L. G. Hupp, who was in active charge at the outset. Since severing my connection with the Hupp Motor Car Co., in August, I have been devoting my entire time and attention to the affairs of the Hupp Corporation. Neither my brother nor myself, nor anyone by the name of 'Hupp' is now connected with the Hupp Motor Car Co. We have notified the Hupp Motor Car Co. that we shall be unable to manufacture any more parts for their cars after November 1. We are planning to market 10,000 new R. C. H. cars during the season of 1912, and our facilities here will be taxed to the limit in turning out our own product."

### Atlanta Automobile Row Is Growing

ATLANTA, GA., Sept. 25—Eleven makers are represented in Atlanta by branch houses or by concerns that amount to that. Here is the list: Overland Southern Motor Company, United Motor Atlanta Company (Maxwell, Columbia, Sampson, Stoddard-Dayton and Courier), Mitchell-Lewis Motor Company (Mitchell), J. I. Case Threshing Machine Company (Case), Ford's Southeastern branch, Corker Motor Car Company (in effect a branch for the Haynes, also carries the Matheson), Stearns Southeastern branch, Southern branch Buick Motor Company, Southeastern Studebaker branch (E-M-F and Flanders).

In addition to the eleven branches, the Gate City of the South has eleven active agencies, most of which are housed in their own places of business with garage accommodations. These are: Krit Motor Atlanta Company, Cole Motor Company of Georgia, Steinhauer and Wight (Cadillac), Scott Motor Sales Company (Pathfinder), Central Auto Supply Company (Imperial), John M. Smith (Pierce-Arrow), Fulton Auto Supply Company (Peerless, Marmon, American and Gramm), E. D. Crane and Company (Hupmobile and Columbus Electric), Clif-

ford V. Anderson (Corbin), Northcutt Company (Chalmers), W. M. Leathers (Dorris), The Auto Company (Thomas, Alco, Oakland), Herman J. Haas (Winton, Rauch & Lang Electric).

### Automobile Eases Rigor of Car Strike

DETROIT, MICH., Sept. 25—Detroit experienced a little object lesson last week that fully convinced everybody that the motor car is a public necessity instead of being merely a luxury. Without warning, Wednesday morning, the city found itself with a street car strike on its hands, the first in 20 years. Not a wheel turned for the purpose of carrying passengers all that day, and yet, thanks to the motor car, citizens were not seriously discommoded. There was considerable confusion in the early morning hours, but toward noon things were running along fairly smoothly. Factories were running as usual, though short-handed in many instances. The downtown stores were well patronized, and even the theaters did a good business.

The worst sufferer, perhaps, was the State Fair management. But for the automobiles, the fair would have been deserted and there would have been nothing left to do but to close down. Motor 'bus lines were quickly established, however, and the fair was well patronized in spite of the high tariffs exacted by the enterprising 'busmen.

### Cincinnati Dealers' Used-Car Scheme

CINCINNATI, Sept. 25—The details for a new system in the trading of broken down and second-hand machines, in part payment for a new automobile, are being put in practical shape for operation here. It will be under the auspices of the Cincinnati Automobile Dealers' Association, and probably operated by the association itself.

The proposition is to establish a general clearing house for second-hand and broken-down cars, with an efficient and independent general manager and corps of expert mechanics. The machines are to be put in first-class order and placed on sale at the expense of and for account of the owner, thus obviating present abuse of legitimate competition in fixing values on them. Under such an arrangement the dealer would not need to fix the price on the machine to be traded, the association to assume that responsibility, together with its repair and sale.

### Saurer and Mack Companies Combine

CHICAGO, Sept. 25—The International Motor Co., with headquarters in New York City, is the title of a new holding and sales company formed by the interests controlling the Saurer Motor Co. and the Mack Brothers Motor Car Co., of which C. P. Coleman, president of the Saurer company, is at the head. The International only was formed last week, and so far there has been no announcement as to the officers or the capitalization.

The organization of the International company marks a departure in commercial motor vehicle circles in that it brings together the Saurer and Mack interests. The new concern, it is said, will act as a sales agent for the two lines of trucks, the idea being that both will save in the expense of marketing their product without in any way interfering with the methods of the two companies as at present constituted. Each will retain its individuality, but the two lines will be marketed by the International company. The combination gives a line of American-made trucks that extends from 1 to 7 tons inclusive.



## NEWS of the WEEK CONDENSED

**DETROIT, MICH.**—The testing out of chassis before they are finally passed upon by the factory experts is carried to the extreme at the Everitt plant. The chassis are put through a stretch of deep sand on high gear, and unless they perform satisfactorily the inspection department refuses to O. K. them.

**BUTTE, MONT.**—Meritt & Riley have been signed up by the Franklin Automobile Company as dealers for the coming season, succeeding The Butte Novelty Works.

**NEWARK, N. J.**—The Johnson Auto Conveyance Company has been established here. The company now employs four Johnson trucks for its freight carting business.

**BOSTON, MASS.**—Harold D. Bornstein has been appointed manager of the New England branch of the Velie Motor Vehicle Company, with headquarters at 92 Massachusetts avenue.

**WASHINGTON, D. C.**—E. C. Bull has been appointed manager of the Pope Automobile Company, agent for the Oakland and Pope-Hartford. Lawrence Schenk has been made manager of sales.

**BOSTON, MASS.**—George E. Stuart, deputy street commissioner of Newton, is being considered as the successor of Chairman Harold Parker, of the Massachusetts State Highway Commission, now that the latter has sent in his resignation. Mr. Stuart is a practical road builder, having been connected with the street department of Newton for many years.

**PHILADELPHIA**—The South Jersey Motor Club will hold a race meet on the fair grounds half-mile track at Bridgeton, N. J., next Saturday. So far twelve cars have been entered.

**MERIDEN, CONN.**—The Connecticut Telephone and Electric Company and the Connecticut Shock Absorber Company have opened a joint branch at 819A Boylston street, Boston, Mass.

**NEW YORK**—The Pope-Hartford Automobile Company has taken over the business of the Pope Motor Company of Jersey City. B. F. Ellsworth will have charge of the new office.

**MILWAUKEE, WIS.**—H. W. Ellis, of Chicago, will hereafter head the sales department of the Johnson Service Company's automobile department here. Mr. Ellis is a new man in the automobile field.

**FINDLAY, OHIO**—At a Fall festival at Defiance this week forty automobiles paraded for prizes. The first prize lay between Mayor Chenevert and Glen Coy, but a flip of the coin gave it to the Coy machine.

**BALTIMORE, MD.**—The D. C. Walker Automobile Company has become the Baltimore representative for the Stearns Silent Knight. The company expects to receive the demonstrator within the next few days.

**YORK, PA.**—Harry R. Pfeiffer, 537 West Market street, has taken the agency for the Stoddard-Dayton automobiles. Mr. Pfeiffer has the sole agency for the Baker Electric for York, Adams and Lancaster counties.

**OTTAWA, CAN.**—The first annual automobile and motor boat show to be given at Ottawa will be staged from April 6 to 13, 1912, at Howick Hall, under the auspices of the Ottawa Valley Motor Car Association.

**HARRISBURG, PA.**—The Fall sociability run of the Motor Club of Harrisburg was held last Thursday to the Allentown fair. Secretary of the club, J. Clyde Myton, laid out the route to Allentown which is about 93 miles. A dozen cars were entered in the run.

**INDIANAPOLIS, IND.**—Nordyke & Marmon Company has entered four cars in the Santa Monica races to be held on the great California course on October 14 according to an announcement made from the factory.

**BALTIMORE, MD.**—The Lambert Automobile Company is preparing to occupy new quarters at Mount Royal and Maryland avenues. The company handles the Maxwell, National and Hudson cars in Baltimore and vicinity.

**DETROIT, MICH.**—Harry Grant will drive the Lozier car owned by Dr. W. H. Chambers in the Fairmount Park road race October 7. Grant will act as a member of the Lozier team despite the private ownership of the car.

**BALTIMORE, MD.**—The Automobile Company of Maryland, agents for the Kissel Kar and truck in this city and the State of Maryland, has moved its quarters from the Academy of Music building to 103 North Liberty street. Robert Stein is manager.

PHILADELPHIA — The Paxton-Crumley Automobile Company, local distributors of the Warren car and of the Warren commercial delivery car, is installed in new headquarters at 660 North Broad street, where an up-to-date agency has been established.

TOLEDO, OHIO—The pathfinder car for the Chicago Motor Club Five States Reliability Contest arrived here this week. The car is in charge of J. P. Dods and is driven by George Daubner. It is expected that the procession will pass through Toledo next month.

PITTSBURGH—The Vestal Motor Car Company has purchased a site for a service station which will cost \$25,000. The company handles the trucks of the Universal Motor Truck Company of Detroit. The building will be at Grant Boulevard and Craig street.

CONNERSVILLE, IND.—A movement is on foot to provide street car service by a system of motor cars of thirty passengers capacity each. It is believed this would be as practical as an electric street car system, and that motor cars could be installed at much less expense than an electric rail line.

COLUMBUS, OHIO—The Robert F. Boda Automobile Company, of 25 North Fourth street, has closed contracts to handle the Mitchell in eighteen counties in Central Ohio for 1912. Subagencies will be selected later. The same company will cover fourteen counties in Central Ohio for the Thomas.

YORK, PA.—Norman R. Galletin, chief road tester for the past seven years, and Steward E. Myers, foreman in the finishing department of the Pullman Motor Car Company's plant, have purchased the Penn

Park Garage, Park and Mason avenue, from A. B. Oden, and changed the name to the Central Garage.

BOSTON—At the meeting of the New England branch of the Electric Vehicle Association of America, at the Edison Building, Boston, an address was delivered by Stephen G. Thompson, of the Public Service Electric Company, of Newark, N. J. Mr. Thompson's subject was "The Electric Vehicle and the Central Station."

KENOSHA, WIS.—The Chicago Brass Company, of Kenosha, Wis., has purchased the buildings and real estate of the Frost Manufacturing Company, which has been specializing in plumbers' goods, and will add the property to its already large plant. The two plants adjoin and the purchase gives the Chicago company a solid block.

TOLEDO, OHIO—The Willys - Overland Company has installed a daily report system by which the office sales force is kept informed of crop, weather and commercial conditions from all parts of the United States, Canada and Mexico. George W. Bennet is in charge of the system and will use it as a barometer in his distribution of cars.

TOLEDO, OHIO—Plans are being made for the organization of a new automobile club here. The idea had its inception last week when the automobile dealers' association met for the purpose of electing officers. The club will not be a dealers' affair in any way and no one who sells automobiles will be permitted to hold office in the organization.

NEW YORK—The International Motor Service Association was formed last week with the avowed purpose of concentrating the purchase of supplies for taxicab, delivery and public service corpora-

tions throughout the country. Charles C. James, general manager of the taxi-cab division of the United States Motor Company, is the founder.

CORLISS, WIS.—W. Owen Thomas, designer of the Owen-Thomas Six, an all-steel car, the rights to manufacture which are owned by the leading stockholders in the Wisconsin Engine Company, of Corliss, has been granted patents on a buffer mechanism for motor cars. It is supposed that the engine company will manufacture the device on a large scale.

MILWAUKEE, WIS.—Although it has only just started to administer the new Wisconsin State aid for road building law, the Wisconsin Highway Commission has already found the \$350,000 annual appropriation insufficient to meet the demands for State aid and has been obliged to scale down the requests of townships and counties to make both ends meet.

ANDERSON, IND.—The Remy Electric Company has announced that it will award cash prizes to the winners in the various events in the Fairmount Park Road Races, at Philadelphia, October 7, and in the Santa Monica races at Los Angeles, October 14. These prizes will be in gold, payable to the drivers, and are conditional upon the cars being equipped with Remy ignition.

SAN FRANCISCO—The Indian Refining Company of New York, manufacturers of Havoline oils, has organized the Indian Refining Company of California as a subsidiary corporation to handle its products on the Pacific Coast. Offices have been established in this city in charge of H. R. Gallagher and J. D. Van Eck, and arrangements are being completed to take care of the entire Pacific coast trade from a central office in this city.



Fifty per cent. gradient over which the Buckeye Manufacturing Company, of Anderson, Ind., tests its Lambert cars

DES MOINES, IOWA—The Cunningham Auto Company has taken the Des Moines agency for the American Traveler car and made a first delivery here last week.

SAN FRANCISCO—The Pioneer Commercial Auto Company of Los Angeles has established a branch in this city for the handling of the Reliance, Rapid and Randolph trucks, all of the General Motors line. F. W. Ball is in charge.

BAY CITY, MICH.—Work has been begun on Bay City's latest industry, the National Auto Truck Company's plant. The contract for the excavations has been let and the work will be completed as rapidly as possible. The contracts for the buildings will be let in parcels, none of the bids for the entire work having been satisfactory.

CHICAGO, ILL.—Instead of being held the week of September 30-October 7, the fall opening of the Chicago Automobile Trade Association will take place a week later, October 7-14, the postponement being caused by inability to complete the electric lighting of the row by that time. At present the dealers have a large fund raised for the purpose of conducting the show.

MILWAUKEE, WIS.—Albert F. Gumz, a member of the Milwaukee County Board of Supervisors, has been granted letters patent on a new type of carburetor or generator for motor cars. The device is a simplification of the ordinary carburetor and is claimed to give positive mixtures at all speeds without numerous adjustments. It is also claimed to be practically climate-proof.

INDIANAPOLIS, IND.—It is expected that a permanent organization of the Hoosier Motor Club will be perfected at a meeting of automobile owners to be held at the Claypool Hotel on the evening of September 29. There will be a dinner and smoker in connection with the meeting and it is expected the club will start with 100 charter members. Charles A. Bookwalter will serve as temporary chairman and P. P. Willis as temporary secretary.

BALTIMORE, MD.—The Automobile Club of Maryland is getting ready for the annual meeting to be held October 10. Dr.

H. M. Howe, president; Thomas G. Young, treasurer; H. M. Luzius, secretary, and Osborne I. Yellott, counsel, are candidates for re-election. Vice-President Jöel G. Nassauer will not run again for office. At a recent meeting the club issued warnings to motorists concerning a speed trap on Wilkins avenue, near the city limits.

FLINT, MICH.—During the Genesee County Fair, October 3, Bob Burman, in his Blitzen Benz, will have a try at the record. The other events for automobiles at the fair are as follows: Cars, Class C, non-stock, cars from 161 to 230 inches piston displacement, five miles. Prize trophy—Cars, Class C, non-stock, cars from 231 to 450 cubic inches piston displacement, three miles. Cars, Class C, free-for-all, three miles. Cars, Class C, free-for-all handicap, three miles.

BALTIMORE, MD.—The Oakland Sales Company, 107 West Mount Royal avenue, of which T. R. Jones is manager, has been appointed the agency for the new R. C. H. car. The company expects to get the first consignment of cars some time during next month. Manager Jones of the Oakland Sales Company has just returned from the Oakland factory in Pontiac, Mich., where he arranged for the shipment of the 1912 Oakland cars. The Oakland Sales Company will move to its new quarters at 6 and 8 East Chase street after November 1.

BALTIMORE, MD.—A report on the proposed plans for the Green Spring avenue boulevard within the city limits was submitted to Mayor Preston by Major Joseph W. Shirley, of the Topographical Commission. This avenue leads from the famous Druid Hill Park to the beautiful Green Spring Valley in Baltimore County, the home of many of Baltimore's smart set. In his report Major Shirley explains that it will cost \$130,000 to carry out the improvements. He also suggested that the roadway be of an average width of 300 feet.

TOLEDO, OHIO.—On an application of the Ewing-American Motor Company, of New York, Judge John M. Killets of the United States Circuit Court, this week, appointed John M. Barr, of Findlay, receiver for the Findlay Motor Company, of Findlay, Ohio. It was alleged that while the company is

not insolvent, it owes debts in excess of \$50,000 and has not the necessary working capital to continue business and conserve the best interests of the company. Representatives of the concern consented to the appointment. Bond in the sum of \$25,000 was immediately given by the receiver who is now in charge.

WASHINGTON, D. C.—Under bids opened some weeks ago the Bureau of Yards and Docks, Navy Department, has awarded the General Vehicle Company, of Long Island City, the contract for furnishing twelve electric trucks to navy yards at Portsmouth, N. H.; Boston, New York, Norfolk, Charleston, S. C.; Mare Island, Cal.; Puget Sound, Wash., and Guam. The contract price was \$49,000. Eight of the trucks will be 5,000-pound machines in four of them 10,000-pound trucks. The 5,000-pound trucks will be of the express type, while the others will be of the stake type. Delivery is to be made within six months.

INDIANAPOLIS, IND.—K. W. Brewer and E. L. Baker have formed the Baker-Brewer Company and have taken the agency for the Baker electric. They have obtained quarters with the downtown salesroom of the National Motor Vehicle Company at 426-428 North Capitol avenue. The Haynes Automobile Company, of Kokomo, has opened a factory sales branch in Indianapolis at 514 North Capitol avenue, with R. P. Dillon as manager. A factory sales branch of the Auburn Automobile Company has been established at 518 North Capitol avenue. Formerly the Auburn was handled by the Finch-Freeman Auto Company.

INDIANAPOLIS, IND.—There is a constantly increasing demand for garages in the residence districts and there is a tendency to erect such garages to conform to the architectural surroundings. The Automobile Owners' Service Company has just begun the erection of a building on the colonial style. This will be two stories high, of yellow pressed brick, trimmed with white. There are to be living apartments at the front of the second story, with a repair shop and machine shop in the rear. Motor cars are to be delivered by men in white livery and a vacuum cleaning system for cleaning cars will be installed.



Among the notable features of the early autumn shipping season is the solid trainload of Flanders cars which left the factory



CINCINNATI, O.—It has been decided by the Cincinnati Automobile Dealers' Association to hold its second annual show in Music Hall during the month of February next. Contract has been listed for the hall, the exact date to be announced soon.

MILWAUKEE, WIS.—Good roads was one of the principal subjects for discussion at the annual convention of the National Rural Letter Carriers' Association in Milwaukee, September 20 to 23. Traveling an average of 26 miles per day on the roads of the United States, the rural carriers are to be considered among the best judges of roads. Several motor car manufacturers made exhibits at the convention, among them Mitchell-Lewis Motor Company, Racine, Wis.; Petrel Motor Car Company, Milwaukee; Schacht Motor Car Company, International Harvester Company and Maxwell-Briscoe Mfg. Company.

SAN FRANCISCO, CAL.—Announcement is made by the Motor Car Dealers' Association of San Francisco that no gasoline pleasure vehicle show will be held in this city by them or under their sanction. This means that there will be no show this season, for, after the unpleasant experience of private promoters who attempted to hold an exhibition last March against the wishes of the association, it is not probable that any such will be attempted again. At that time the organized dealers published several announcements that they were not participating, and this, combined with bad weather, resulted in serious financial losses to the promoters.

MILWAUKEE, WIS.—As a result of the convincing demonstrations and tests made by manufacturers of motor-propelled fire-fighting equipment during the twenty-third annual convention of the International Association of Fire Engineers in Milwaukee, September 19 to 23, the Common Council of Milwaukee will proceed at once to motorize the entire equipment of Central Fire Station, Broadway and Oneida street.

MONTREAL.—The \$6,400 motor-driven combination hose wagon and chemical engine, which was authorized by the Westmount Council Tuesday night, will be the first piece of fire-fighting apparatus of its

kind to be adopted in Montreal and in fact in the province of Quebec. Westmount's experiment will be watched with interest by the Montreal Fire Department, which has for some time past been contemplating the purchase of a similar piece of apparatus.

GRAND RAPIDS, WIS.—The Commercial Club of Grand Rapids has obtained sufficient subscriptions to meet the guarantee demanded by W. A. Crowe, of Detroit, who proposes to manufacture a new 30 horsepower car to be known as the Crowe. It is now considered certain that the new Crowe plant will be established in Grand Rapids. It is proposed to incorporate for \$200,000, of which amount \$40,000 is to be awarded to Mr. Crowe and W. M. McIntyre, designer of the car, as their share for patent rights, designs, tools, etc.

SAN FRANCISCO.—The White gasoline pleasure cars are now handled in San Francisco by the Davis Auto Company, organized for the purpose. The White company's branch here retains the truck end of the market. Frank H. Davis, long associated with the White branch, is manager of the Davis Auto Company.

RICHMOND, VA.—With the proviso that the money be expended within ten miles of the city, the finance committee of the City Council has recommended the appropriation of \$5,000 by the Council toward the Gordonsville-Richmond-Old Point highway improvement. Private subscriptions amounting to over \$6,000 have been made toward the improvement of the highway, and more donations are being solicited. The counties and towns along the highway are coming across liberally and every indication is that a sum sufficient to put the highway in the very best of condition will be raised.

CHARLOTTE, MICH.—The Duplex Power Car Company's affairs took a new turn when the adjourned annual meeting of the company was held and an entirely new set of officers and directors was chosen to take charge of affairs, comprising Frank P. Town, James H. Brown, Robert Donovan, W. G. Wisner, Frank King, W. B. Fulton and M. J. Lamson, all local men. Later the board met and elected the following officers: President, Frank P. Town; vice-president, Frank King; secretary, W. G. Wisner; treasurer, Carroll S. Brown.



## Automobile Incorporations

### AUTOMOBILES AND PARTS

BOSTON, MASS.—Hollander Motor Co.; capital, \$15,000; to sell motor vehicles. Incorporators: Wilkie B. Hollander, George M. Wetherbee, Robert A. Jordan.

DAVENPORT, IA.—Davenport Auto Co.; to deal in motor cars. Incorporators: A. A. Liberman, Charles E. Frey.

FATAAUAU, GA.—Piedmont Auto Manufacturing Co.; capital, \$100,000; to build automobiles. Incorporators: Robert F. Butler, W. L. Moor, H. Knight.

MARIETTA, OHIO.—Pioneer Motor Car Co.; capital, \$18,000; to make and deal in automobiles. Incorporators: Tasker B. Bosworth, A. J. Watson, A. A. Crawford, T. McCune, H. B. Coen.

NASHVILLE, TENN.—Hicks Motor Truck Co.; to make freight automobiles. Incorporators: W. L. Hicks and others.

NEWARK, N. J.—Merchants Motor Car Co.; capital, \$500,000; to manufacture automobiles.

PROVIDENCE, R. I.—Providence Motor Car Co.; capital, \$25,000; to sell automobiles and conduct garage business. Incorporators: John A. McDonald, William H. McSoley, Alice Stanton.

RICHMOND, VA.—Motor Truck Corporation; capital, \$25,000; to operate a motor transfer business. Incorporators: H. A. Gillis, T. M. Garrity, Charles Laurens, E. P. Cox.

UTICA, N. Y.—Tompkins-Creedon Co.; capital, \$5,000; to deal in automobiles. Incorporators: Wm. Tompkins, Dennis P. Creedon, Ella Creedon.

TERRE HAUTE, IND.—Smith Motor Car Co.; has changed name to Terre Haute Motor Co.

WILMINGTON, DEL.—Union Motor Car Co.; capital, \$25,000. Incorporators: Edmund S. Hellings, Charles B. Busb, Armon D. Chaytor.

### AUTOMOBILE GARAGES, ACCESSORIES, ETC.

BUENA VISTA, VA.—Buena Vista Garage & Automobile Co., Inc.; capital, \$5,000. Incorporators: W. B. Pritchard, S. H. Yoekely, D. S. Bromley, N. B. Pritchard.

CLEVELAND, OHIO.—Sea Island Tire Co.; capital, \$15,000; to make and sell tires and tire protectors. Incorporators: J. C. Brooks, A. L. Welch, A. C. Miller, D. C. Westebaven, W. H. Boyd.

NEW YORK CITY.—Green's Auto Vans Express Co.; capital, \$12,000. Incorporators: James C. Green, Michael Green, Daniel S. Green, Joseph Green.

NEW YORK CITY.—Smith Gasoline Meter Co.; capital, \$350,000; to make and deal in engines, motor cars, etc. Incorporators: W. H. White, Jr., D. M. Baldwin, W. H. Brady.

CAMDEN, N. J.—New Jersey Automobile & Supply Co.; capital, \$125,000; to sell automobiles. Incorporators: H. Morgan Hatch, J. R. Mick, Wilfred B. Walcott.

JERSEY CITY, N. J.—Moran's Garage & Auto Co.; capital, \$25,000; to sell automobiles. Incorporators: Otilie R. Moran, John E. Moody, Wm. A. Higgins.



at Detroit for the Kansas City branch recently. The train was made up of 34 cars, and 100 automobiles constituted the shipment

# OF INTEREST *to the* INDUSTRY

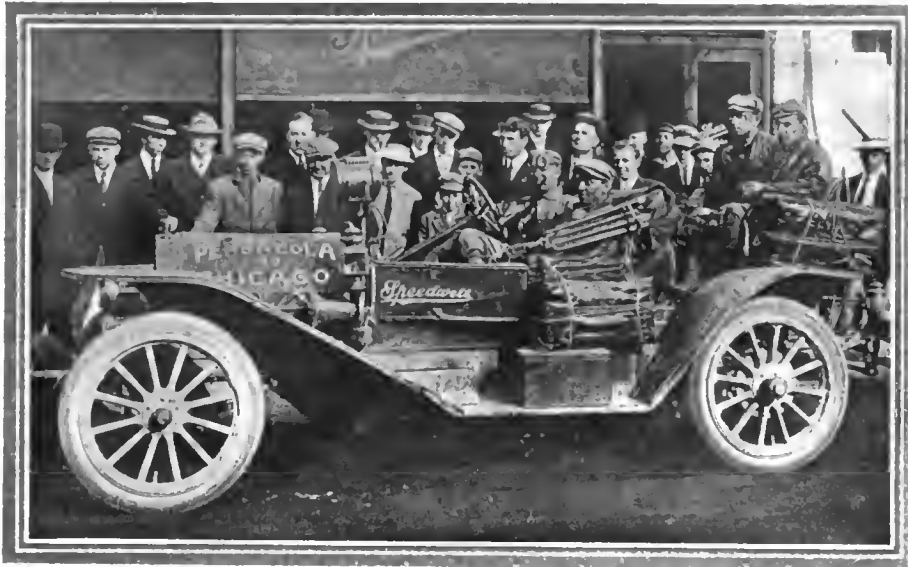

**CHICAGO, ILL.**—There recently arrived here from Pensacola, Fla., the Speedwell Pathfinder, which left the Southern city nine days before to lay out a Gulf-to-Lakes route designed to facilitate and encourage motor travel between the South and North. The trip was made under the auspices of the Pensacola Commercial Association, with Dr. Mallory Kennedy in direct charge of the work. Although no effort was made to cover the distance speedily, the time consumed on the long journey is considered remarkably fast. The information gathered en route by Dr. Kennedy is to be put into convenient shape by the Association.

**SYRACUSE, N. Y.**—R. A. Vail, assistant chief engineer in the Franklin factory, has resigned. A delivery wagon of 1,000-pound capacity is a feature of the commercial car line of the Franklin Automobile Company as it is presented for the coming season.

**RACINE, WIS.**—The J. I. Case Threshing Machine Company is now giving its new petroleum engine a thorough tryout in connection with a threshing machine. The motor car department of the Case company is taking considerable interest in the new type and experiments are being made in this department. The engine is designed by David Evans.

**SYRACUSE, N. Y.**—John A. Nichols, Jr., former district manager for the Franklin Automobile Company in the Canadian and American Northwest, has been made superintendent of the Franklin branches, with headquarters here.

**GRAND RAPIDS, MICH.**—The Mercury Manufacturing Company, a Chicago firm which manufactures the Mercury half-ton trucks, has chosen Grand Rapids as the

place to enter into Michigan competition. Its first branch in this State has been established at 318 Kent street. The company is represented by James Hoogerhyde and C. Fisher.

**CHICOPEE FALLS, MASS.**—H. B. Curtiss was recently placed in charge of the Service Department of the Stevens-Duryea Company at its factory. Mr. Curtiss was formerly connected with the Pierce-Arrow factory organization.

**DETROIT, MICH.**—By the middle of November the Abbott Motor Company expects to get into its new addition. This building is 40 by 160 feet and will be used for final assembly and general storage purposes. The new office building will be ready by Oct. 20.

**LIMA, OHIO**—Steps have been taken by the Gramm Motor Car Company of Lima, Ohio, to increase the capital stock of the corporation from \$300,000 to \$1,250,000, for the purpose of increasing the output of the plant. Of the increased stock half will be common and the other preferred.

**DES MOINES, IOWA**—W. R. Jones has been named manager and has taken charge of the Des Moines branch of the United States Motors Company. Mr. Jones was formerly in charge of the Kansas City branch. He succeeds H. B. Groves, who has gone to the Pacific Coast.

**AMESBURY, MASS.**—The new plant of the Castle Lamp Company at Elmira, N. Y. is approaching completion and will be ready for occupancy October 15. The building is 227 by 85 feet, three stories high and constructed of steel and cement. The Amesbury plant will be removed to Elmira.

**SAGINAW, MICH.**—John Trumble, of Detroit, has been appointed superintendent

of the engineering department of the Marquette Motor Company and has assumed his new duties. The Saginaw plant is being used strictly as a manufacturing adjunct to the General Motors Company, and besides building its own cars is making all parts of Welch-Pontiac and Welch-Detroit cars and furnishing them to owners of these automobiles.

**LANSING, MICH.**—The fiscal year of the General Motors Company has been changed so as to end July 31 in place of September 30, as heretofore, in order to permit the manufacturing department to take inventory at the most convenient time of the year. This will mean that the forthcoming statement of earnings will be for a ten-months' period, running from October 1, 1910, to July 31, 1911.

**LOUISVILLE, KY.**—Berton B. Bales has resigned as president of the American Automobile Manufacturing Company, whose offices and plant are situated across the river from this city in New Albany, Ind. It is understood that George H. Wilson, of Louisville, will be selected as Mr. Bales' successor. The latter will retain his interest in the company, but will devote his time to his private business affairs. The company makes the Jonz car and at present about sixty workmen are employed.

**BROCKVILLE, CANADA**—The Brockville Atlas Motor Car Company, with a capital of \$200,000, has been established at Brockville, Ont. A new factory with all the latest facilities is in course of construction. This company will build four different types of cars—touring car, runabout (two models) and commercial car. All the parts will be built by the company with the exception of the engine and body. The engine will be the output of The Atlas Engine Works of Indianapolis and the bodies constructed by the Canada Carriage Company. Mr. T. J. Storey is the managing director.

**AKRON, OHIO**—The annual meeting of the stockholders of the Swinehart Tire & Rubber Company was held at the offices of the company recently. Very satisfactory reports were made of the progress of the company during the past year, the business showing an increase over the previous year of 200 per cent. The prospects for the coming year are very good, the factory operating day and night to take care of the increased business. The following were elected as directors for the ensuing year: August Blossman, R. A. May, L. Mather, Wm. McWeldon, W. W. Wuchter. After the stockholders' meeting the board was organized and the following officers elected: W. W. Wuchter, president and general manager; Joseph Dangel, vice-president; C. O. Baughman, secretary; R. A. May, treasurer.

# PATENTS GONE TO ISSUE

**ROLLER BEARING**—Anti-friction bearing containing two sizes of rollers.

2. The bearing shown in Fig. 1 comprises spaced concentric race rings I and O, the inner ring I having a peripheral groove G with outwardly inclined edge portions at its sides. Ring I also has annular wearing surfaces W on opposite sides of the edge portions mentioned, and at the outer edges of these annular surfaces radially disposed flanges are spaced. Working rollers R<sub>1</sub>, the ends of which have beveled edges, are located in the peripheral grooves G, and these rollers are held apart by separator rolls R<sub>2</sub>, which bear against the surfaces W and are interposed between the flanges and a retainer R<sub>3</sub> which has spaced openings through which the working rollers R<sub>1</sub> pass into coaction with the outer race O.

No. 1,003,551—to Colcord Upton, Baltimore, Md., assignor to Simplex Roller Bearing Co., New York City. Granted, September 19, 1911; filed June 8, 1911.

**COMBINED MUFFLER AND AIR HEATER**—Air playing around the silencer is heated by the exhaust gases passing through same.

2. This patent relates to the device shown in Fig. 3, in which C denotes an outer muffler casing having an exhaust inlet I at one end and an exhaust outlet O at the other. Intercommunicating sections are arranged transversely of and closely fitting the interior of the casing, each section being formed by two oppositely disposed, centrally perforated members M and N having flanged edges and a baffle plate B located between them. Plate B is perforated at P and P<sub>1</sub>, beyond its center, and at its margin it is connected to the flanges of the two concave members mentioned. Thus the outer margins of the hollow sections have openings out of alignment with each other, which provide a tortuous gas passage. While the exhaust passes through the plurality of sections, air, which is permitted to enter at A, flows around these sec-

tions as indicated by the arrows, until it reaches the discharge opening D whence it streams through a pipe to the ventilator cap V arranged in the wall of the automobile body B.

No. 1,003,620—to Edward Dudley Lewis, Elmira, N. Y. Granted September 19, 1911; filed April 18, 1910.

**ADJUSTABLE BRAKE**—By means of a bolt tension on brake-band may be altered.

1. In Fig. 4 is shown the combination with a drum D and a fixed support S of a brake band B, B<sub>1</sub> encircling the drum and carrying a stud S<sub>1</sub> at one of its ends. In this stud a bolt B<sub>2</sub> is adjustably mounted, which is connected to the link L, one end of which is pivotally mounted on the support S and the other connected to the free end of the bolt. An operating lever O has one end pivotally connected to the brake band at P, while the other end E, when in use, is connected to an operating rod, the intermediate portion of the operating lever being connected to ends of link L and bolt B<sub>2</sub>.

No. 1,003,621—to Charles L. Lincoln, assignor of one-half to Samuel H. Wheeler, Bridgeport, Conn. Granted September 19, 1911; filed December 28, 1910.

**ODOMETER**—Distance meter of the kind connected directly to the wheel hub.

1. This device comprises an annular housing adapted to embrace the wheel hub, a registering device within the same and an actuating device for the register consisting of a circularly curved lever having a fulcrum within the annular housing and on one side of the center of same, a weight being attached on the opposite side of the annular housing with respect to the center of the wheel hub, and means for connecting the circularly curved lever to the register.

No. 1,003,623—to Kendree Littleton, Pacolet, S. C. Granted September 19, 1911; filed May 23, 1911.

**PNEUMATIC VEHICLE CUSHION**—Shock absorber taking thrust by inflated tubes.

3. The invention protected by this patent is seen in Fig. 2. Above the spring S the axle A is mounted, which carries the cushioning device consisting a frustrum-shaped member F mounted directly on the axle and extending above it as shown; F has an horizontally extended base B, between which and an upper inverted-dish shaped member U pneumatic tubes P and P<sub>1</sub> are interposed. Rods R are fastened to the spring and pass through the frustrum-shaped member, and they are bolted to the member U at B and B<sub>1</sub>, permitting U to vibrate vertically with the spring.

No. 1,003,579—to George J. Bancroft, Denver, Colo. Granted September 19, 1911; filed June 7, 1910.

**ENGINE SILENCER**—A muffler construction in which the gases pass through a spiral passageway.

1. This muffler consists of a casing containing semi-circular sections arranged to form a continuous spiral passage through the casing, the sections adjacent the inlet having central apertures while the other sections have closed conical centers with their apices toward the muffler inlet.

No. 1,003,531—to Lonnie C. Smoot and Wm. R. Masterson, Hillsboro, Tex. Granted September 19, 1911; filed Sept. 6, 1910.

**TIRE PROTECTOR**—A system of cables and rings is employed to keep the pneumatic tire in place on the wheel rim.

This patent relates to a tire protecting device, which consists of two rings encircling the wheel rim adjacent to its two sides. Around the rings and over the tire tread is led an endless cable, and to prevent slippage of the cable clamping rings co-operating with the first-mentioned rings are used, which are secured in their places.

No. 1,003,815—to Charles Scott, Baker, Ore. Granted September 19, 1911; filed May 10, 1911.

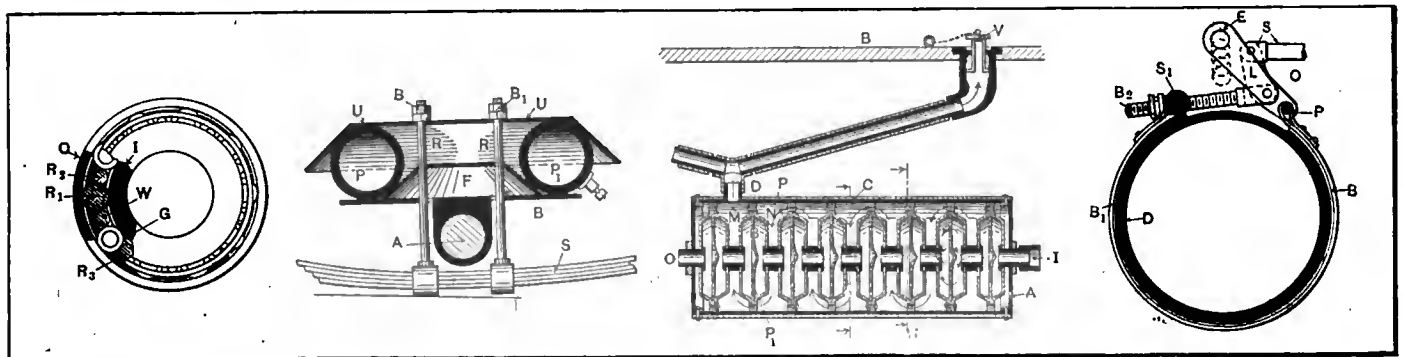

Fig. 1—Upton Bearing. Fig. 2—Bancroft Shock Cushion. Fig. 3—Lewis Heater. Fig. 4—Lincoln Brake

# Newest Ideas Among the Accessories

## Star Safety Starter

**T**HE Star Starter, which is shown in Fig. 1, serves to start a motor car from the driver's seat by means of a lever, and it contains in its construction

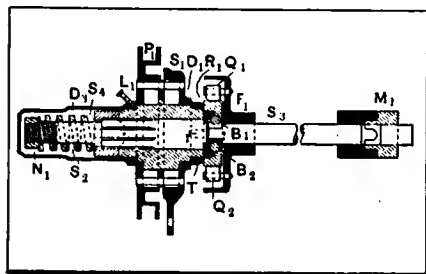

Fig. 1—Section through Star starter

a safety feature protecting the operator from the effects of backfiring. The front view of a car equipped with the Star starter is seen in Fig. 2, where P1 represents a pulley around which is wound the starting chain C1, which is led around pulley P2 to the operating cable actuated by the lever beside the driver. C2 is the castellated front end of the starter housing, and around it is fitted the dog D3 holding it to the frame by means of two bolts. In Fig. 1 the mechanical details of the starter are depicted, P1 denoting again the main pulley, which is fastened by pins to the frame S1 of the starter. These members are arranged around the starter shaft S4, carrying also a ratchet R1 and dog D1. Shaft S3 runs on a ball bearing B1, B2. To the dog F1 two pawls Q1 and Q2 are connected by means of bolts, these pawls engaging the ratchet and insuring its rotation in one direction only.

Referring to the front end of the starter, it consists of the spring S2 which is wound around S4 and serves to counteract the initial compression of the motor, while nuts N1 are used to adjust the tension of the spring. The whole of this part of the

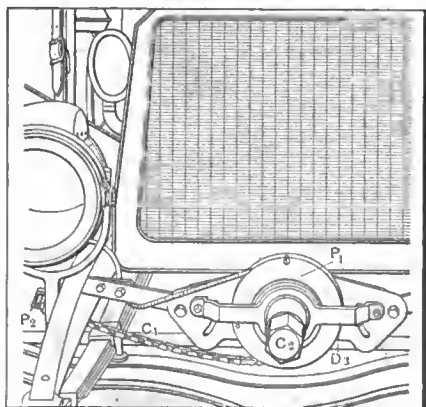

Fig. 2—View of Star safety starter

starter is covered by the dust-cover D2, fastened to pulley P1 by lock stud L1.

In starting, the chain being pulled toward the driver turns over pulley P1, which it engages, and also starter frame S1 pinned thereto. The engagement of pawls and ratchet causes shaft S3 to be turned over, and a minimum amount of work is expended in starting as the compression of the motor is balanced by the spring S2 and as the ratchet is carried on a ball bearing. Shaft S3 twists the crankshaft M1 of the motor around, thus starting the engine. Should the motor back-kick, the pawls will keep the ratchet from reversing its motion. Likewise, after the motor has

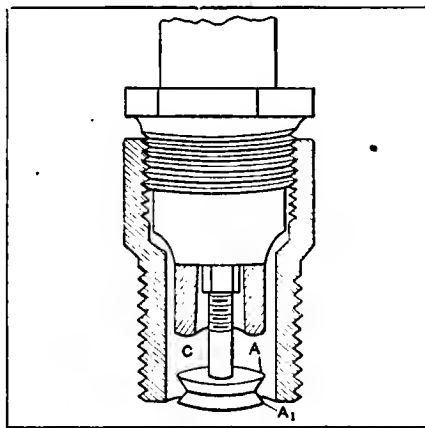

Fig. 3—Section of Maher Duplex plug

been started, the pawls are thrown out of engagement with the ratchet (and starter) by centrifugal force. The Star Starter Company of Rochester, N. Y.

## Duplex Spark Plug

The Maher Duplex Multi-Spark Plug, claimed by its makers to be self-cleaning, has a double annular spark gap (Fig. 3), formed by two cone frustums fixed at their smallest portions and centrally disposed in the bottom end of the spark plug body. The flange A of the upper frustum serves as a normal sparking "point," while the lower flange B provides an auxiliary gap. The lower flange also acts as a baffle plate closing the firing chamber C against oil from the cylinder space. In the firing chamber gasoline-air mixture is stored and compressed during the compression stroke, and when ignited it expands most rapidly, shooting out of the firing chamber and tearing soot and foreign matter off the spark-gap flanges. The Duplex Multi-Spark Plug Company, of Devil's Lake, N. D., makes this plug.

## Perfect Window Regulator

The device shown in Fig. 5 is the product of the Perfect Window Regulator Company, of 43 Exchange Place, New York City, and is intended to do away

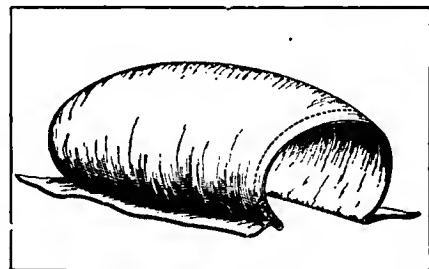

Fig. 4—Security blowout tire patch

with the troublesome strap generally used for opening the window of a closed car. Fig. 5 shows the window which is fastened to cam plate C1, which is held by the spindle S to the chain C2. This chain is led over the two sprockets V and W, and the latter may be rotated by means of the handle H, thereby lifting or lowering the window. The handle contains a clutch member holding it locked in any position, but permitting it to be released by turning.

## Security Blowout Patch

The Security blowout patch (Fig. 4) is intended to be used between the inner tube and the tire casing to prevent blowouts or to serve as a repair in case of blowouts. It is composed of a series of tire-fabric layers, moulded on an aluminum form, giving it the exact dimension of the inside of the casing. The outside of the patch is coated with a quick vulcanizing compound. It is made by the Security Reliner Company, Montgomery, N. Y.

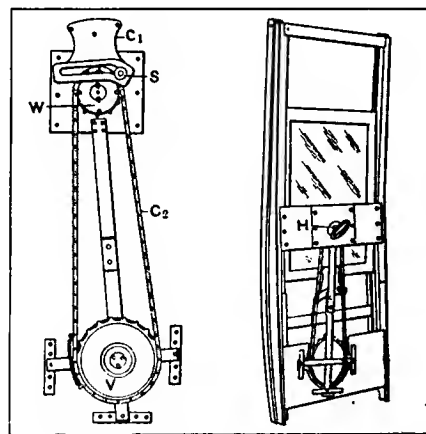

Fig. 5—Views of Perfect window regulator



# THE AUTOMOBILE

## Commuting via the Automobile



HOSTS OF CARS CARRY SUBURBAN OWNERS TO AND FROM RAILROAD STATIONS EVERY BUSINESS DAY IN THE YEAR

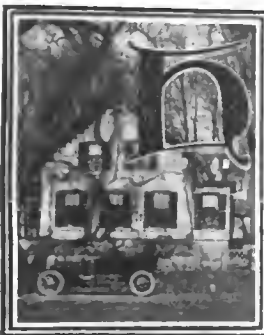

OW many are aware that residential building on Manhattan Island is steadily decreasing, despite the vast improvements that are being placed in Harlem, Washington Heights and throughout the north end? Yet it is true. The millionaires have stopped erecting palaces in central New York City, and the reason for this condition rests upon the automobile.

There is still plenty of space for such castles as those of Carnegie, Rockefeller, Clark, Vanderbilt and Astor, but the fact remains that new buildings of their class are not being erected and are not in prospect as far as Manhattan Island is concerned.

Likewise, and even more important, as showing the trend of affairs, is the condition to be noted with regard to homes for business men in comfortable circumstances, who do not come within the multi-millionaire class. They, too, are avoiding the building of homes on Manhattan Island, precisely the same reason applying as does to the situation of the very wealthy.

The figures for the first six months of 1911, covering building permits issued for construction and alteration on Manhattan Island, reach a total of \$62,662,717. As about 70 per cent. of all building permits in any one year are issued during the first six months of the calendar period, the expectation of Manhattan for the whole of 1911 is for buildings to cost \$89,518,160.

In 1910 the total of all building permits was \$108,643,090, thus indicating a decrease this year of \$19,124,930 as compared with the estimated figures for the year. From 1909 this slumping tendency was even more noticeable, as the total amount of the





The automobile plays an important part in keeping the suburbs in touch with the metropolis

permits was \$144,103,507, and 1910 showed a decrease of \$35,460,417 in comparison.

One will look in vain to business conditions for a reason upon which such a decrease in city building can be predicated.

On the other hand, the places near New York that were considered wildernesses only a few years ago are now crowned with splendid homes. From the city limits on all sides the city is growing. Even as far as 40 miles from Wall street, the captains of industry, as well as the lieutenants, sergeants, corporals and privates, have been busy in building their homes.

Take an automobile and go out from New York in any direction, either up-state, across in Jersey, out into Connecticut, upon Long Island or down on Staten Island, and the striking feature of the trip will be the vast number of fine new residences that have gone up recently or are in process of construction.

To the automobile solely is due the credit for this expansion, for, in the broadest sense, the scattering out from the centers of

congestion is wholly advantageous. No man would contend that it is not more pleasant to live and sleep in a comfortable modern house, surrounded by the beauties of nature and far from the noisy pavements and the crush and jam of the great city, than it would be to live in the same kind of a house in the midst of the urban maelstrom. On the other hand, the spaces vacated by those who are able to make the transfer of their homes from the city to the country, allow room for others to move in, and by gradual transition the teeming East Side is relieved.

Out on the rocky Connecticut hillsides, miles away from any railroad, the building is going on industriously. Away north of Mount Vernon, White Plains and Larchmont, in Westchester County, palatial homes are being added each season by the dozen; far to the east of the lateral median line across Long Island, the seekers for the surroundings of nature for their homes are spreading out; while in Jersey the same trend is pronounced.

The Connecticut farmer to whom had descended a big, barren stretch of land close to the Westchester County line and who was about to abandon it five years ago because he could not wring a living from its dry soil and hard rocks, and who despaired of getting \$10 an acre for his homestead, faces a very different situation to-day. Then he could find no one to lend money on such land and no one would agree to pay the taxes and work it on shares, or any other way.

With the coming of the automobile, which brought good roads in out-of-the-way places and a stream of wealthy tourists who could appreciate the natural beauty of the landscape without being impressed with the barrenness of the country, the price and value of his land increased wonderfully. The farmer who held his 160 acres through those dark years is beyond want to-day, for in many sections of Connecticut, near New York, values have risen from \$5 an acre to \$500, and in particular cases to as much as \$3,000 an acre.

This same land to-day is worthless for agriculture and could not be made to pay as a farming project except through the use of scientific fertilization and the modern school of production. But it forms the groundwork for dozens of fine country homes where New York business men rest and recuperate from the fierce strain of their work.



Cement and tile are frequently seen in the structural work of modern country homes

This is the way they do it: Suppose that a wealthy New York family in touring about the Connecticut hills, or Westchester wilderness, or Long Island woods, or Jersey mountains, finds a wild crag or wooded hillside or smiling valley and thereupon decides to push back the limits of space and get away from the nuisance of the crowds, the bustle, noise and discomfort of the city to enjoy the calm peacefulness, the good air, the beauty and the elbow-room of the country.

Crags, woodlands, valleys and hillsides have had a persistent bull market for the past two years or more, and it is likely that the family will have to pay roundly for the home site, but when the idea is once firmly implanted it is the hardest of all human ideas to displace and as a general rule the trade is closed.

Then the home is built and the family moves in. If the place is several miles from the railroad, so much the better. In the morning the head of the house and male members who have business in the city, step into the touring car, and, after a bracing ride, reach the station, and from anywhere within a radius of 40 miles can be anywhere in New York within the hour. The feminine members of the household can run all the way into town in the limousine or touring car for shopping or social duties and be at home by dinner time.

Then to go back again to the men: When the 5:17 train pulls into the home station, father and the boys and the visitors for a week-end, for instance, alight and the seven-passenger touring car whisks them out into nature's domain and lands them at home with sharpened appetites and alert minds and bodies.

The above illustration might be said to describe the method of life of 100 very rich men who still own vast homes on Fifth avenue and Broadway, but who spend nine months in each year at their country places, besides appearing at their offices every working day in the year except while on vacation.

For every one of the above there are 100 men in moderate circumstances who have abandoned New York City as a place of residence while still maintaining their business connection with the big town. Many of these live in isolated spots like their very rich brethren, but the bulk of them form the backbones of communities surrounding New York like the circumference of a circle. In the Oranges of New Jersey, it would be difficult to



A typical country residence and small garage located where participation in New York life would be impossible without the automobile

throw a half-brick without hitting a Standard Oil officer; in Englewood, about 20 per cent. of the wealthy class make the pilgrimage to Wall street daily; Mount Vernon, Yonkers, White Plains, Pelham, Larchmont and the outlying districts between them contribute a vast army of solid citizens every day, while the hill country of Connecticut, west of Stamford, is honey-combed with the homes of New Yorkers. The same may be said for Long Island and Staten Island, and every last one of the families represented by this newest and most effective back-to-soil movement owns at least one automobile.

But there is still another class involved in this development—the high-salaried employees of the New York business houses and the prosperous business and professional element. These are moving out of the congested center toward the comfortable circumference of the circle. They are striking out beyond the reach of what is ordinarily considered quick transit, and are building homes amid rural surroundings. An automobile, even



Sometimes the owner of a fine new house in the country will convert an old barn into a garage



Wooden building used to house the car of one suburbanite who has business in New York

if it is a small one, is to be found in practically every back yard, and those who have no car now intend to get one shortly.

The reason for the certainty of their movements lies in the automobile alone, because science and economy have proclaimed and experience has proved that the laborer cannot live more than 1 hour away from his work. If in the absence of street cars or other transportation to take him to the railroad station, a man is obliged to walk 2 miles or more, which requires at least one-half hour in good weather, and added to this, another half hour is allowed on the train, the limit is reached. With an automobile to carry him to the station in 5 minutes, it would be possible, from the viewpoint of practical economics, to live 55 minutes by train from his work.

Society is being gradually forced north by the inexorable decree of business. Already the encroachments of trade have squeezed the millionaires out of their homes in lower Manhattan, and the trend has grown so pronounced within the past three

years that its significance can no longer be hidden. Hard-headed capitalists, real estate experts and economists generally are assured that in the course of a decade Manhattan Island will contain very few individual homes. In that day, they predict with confidence, that the resident population of New York will consist of apartment and hotel dwellers, to say nothing of the tenement millions. The real homes will all be out in the adjacent country, and every man who can own one will do so. Along with the home, and an essential part of it, is the automobile.

Even at present, the important part played in this movement by the automobile is generally recognized. Take, for instance, the morning the accompanying pictures were taken. The representative of *THE AUTOMOBILE* and the staff photographer first went to the Fort Lee ferry where one of the boats from the Jersey side was about to make a landing. On the boat were 18 vehicles of various sorts. There was 1 furniture van, 2 small trucks, 5 automobile runabouts, 6 touring cars and 4 limousines and town cars. In nine of the automobiles there were ladies, living at various places in Northern New Jersey, who were coming over to New York in the driving rain for shopping and social calls. The superintendent of the ferry said that on a fine day all the morning boats carried full loads of automobiles from 10 o'clock until noon.

These ladies are as certainly and as irrefutably New Yorkers as if they were living on Riverside Drive or Fifth avenue. They retain their intimate hold on the old conservative element of society that still fights stoutly against the incursion of business and consequently maintains its outposts on Manhattan Island.

They patronize the great commercial establishments of New York with even more freedom than did their ancestors, for it is easier to travel from Englewood or South Orange to New York to-day, via a big, comfortable limousine, than it used to be to drive down to the shopping district from upper Fifth avenue.

The representative of *THE AUTOMOBILE* discovered a number of fine private garages while seeking information on this subject. Some of them cost large sums of money and others very little. Perhaps the best type of garage at reasonable cost that was found is the one built by Dr. Best, of Englewood, N. J. As the accompanying picture shows, it is located back of his resi-



Dr. Best's garage at Englewood, N. J. This is built of concrete and cost \$445

dence and next to the tennis court. It is 14 feet square and is built of solid concrete based upon broken blue-rock. This garage cost Dr. Best \$445, and is ample in size and convenient.

Garages of wood cost various sums, and one of those shown herewith, of the same size as Dr. Best's, cost \$800, while the one with the tiled roof cost \$1,200.

Many suburban residents ride all the way into the city in their cars. Of course this does not mean that the owner goes all the way to Wall street through the mazes of traffic, as a general thing. Occasionally such practice is used, but in the vast majority of instances where the car is driven within the city, the owner alights at some subway station and continues his journey via the tubes. In such cases the car is usually garaged nearby until the owner is ready to return home.

In the vicinity of 181st street, 145th street, 96th street, 72d street and Columbus Circle, the garages do a considerable and growing business of this character.

Living out in the country and doing daily business in the city will not save much money, if it saves any at all. The situation as it stands is hardly one of choice for the New Yorker. He is forced to move away by a power which he cannot control.

Take a typical case as an illustration: The head of the family earned a salary of \$5,000 a year and the family consisted of himself, wife and two half-grown children. They lived in one of the fine apartment houses on upper Broadway and paid \$65 a month for rent. They employed one servant at \$30 a month, and their living expenses, administered with care and economy, averaged \$150 a month. Incidentals called for \$25 a month more and transportation, amusement, clothing, insurance and the education of the children accounted for \$160 a month. The total yearly expense of this family, therefore, was \$160 more than the total earnings of the provider.

Fortunately, the family had some other resources, and when the true significance of the situation was understood and it was realized that the children were growing up under appalling conditions and that value was not being received for the tremendous outlay in all directions, it was determined to move out into the country. This family selected a location out on Long Island



Many New York business men lend a touch of the artistic to the building of their garages

and invested \$6,500 in building a home. The site is 6 miles from a railroad station, and so an automobile was found necessary. This cost \$2,500. Living expenses were only slightly decreased, but a considerable item was saved in general and incidental expenses. At the end of the first year the family discovered their financial situation to be about as follows: Interest and taxes on home and car, \$540; living expenses, \$1,650; general and incidental expenses, \$1,500; service, \$300, and the cost of operating and maintaining the car, \$930. This gave a total of \$4,920.

As an actual economy in money terms this means only \$240 a year; but, on the other hand, the family has an infinitely better home, and the children, instead of being cooped up with hundreds of others at home and jammed together with a miscellaneous assortment at school, are attending a select institution near at hand and living out-of-doors most of the time under ideal conditions for their physical well-being.



Broad street, in New York's financial center. Most of these curb brokers live in the suburbs and own cars





De Palma in Mercer, No. 8, leading the field in the five-mile race for non-stock cars under 301 cubic inches

## Short Program at Guttenberg

THE Guttenberg track races were run off according to schedule last Saturday in spite of the rain which fell the day before the race. The track had dried under the influence of the wind and the warm sun and was in ideal condition for the races. The attendance was very good, a large number of those present coming in automobiles.

The races were well contested and furnished plenty of excitement for those who were clustered in the grandstand and in the enclosure. DePalma proved to be the chief attraction in his endeavors to lower the existing records for the track, which is a 1-mile dirt course of elliptical shape.

The 5-mile non-stock event for private owners proved to be the most closely contested race. There were three Regal cars entered, each driven by its owner. Sam From led the field on the first lap but was gradually overhauled by Ira Vail, who won the money. This event was the last of the contested races as after De Palma had lowered the track record for the mile, the 5-mile free-for-all was scheduled and that ended in an accident.

There were three entries in the free-for-all—De Palma in a Mercer, Grey in a Schacht and Koopman in a National. De Palma got away first but close on his heels was the National which clung to the inner edge of the track. The first lap was circled with these two far in the lead and the National car slowly creeping up. When the second lap was started they were so close that all those assembled rose to their feet to watch the speeding cars. The end of the ellipse was reached and both cars swung around the turn, the National just behind the Mercer. The Mercer car had just about reached the

straighter part of the course when a cry went up. The National car had struck the inner edge of the track and bounded high in the air, revolving as it fell and striking the ground upside down. Koopman was pinned beneath the upturned car, while his mechanic lay in a pool of blood alongside the track. Both were picked up and carried away from the blazing car to the field hospital. The car was badly smashed, especially the front axle and the steering gear. The damage to the motor was comparatively slight. The injuries to the crew of the damaged car are feared to be serious, although not necessarily fatal.

The program was concluded by a 5-mile exhibition race against time by De Palma in a Simplex. He broke the Guttenberg track record for this distance. The summaries:

Five Miles, Non-Stock, Class E, Under 231 Cubic Inches			
No.	Car.	Driver.	Time.
5	Paige-Detroit	Bill Regan	6:28 3-5
4	Regal	Chas. Tate	6:33 3-5
11	Regal	Emery Smith	6:58 3-5
Five Miles, Non-Stock, Class E, Under 301 Cubic Inches			
8	Mercer	Ralph DePalma	5:38 1-5
3	E. M. F.	Jack Towers	5:45 2-5
6	Schacht	J. M. Grey	6:07 2-5
5	Paige-Detroit	Bill Regan	.....
Five-Mile, Non-Stock, for Private Owners			
12	Regal	Ira Vail	6:40 4-5
10	Regal	Sam From	7:05 1-5
11	Regal	Emery Smith	.....
Five-Mile, Free-for-All			
Not finished owing to accident to National car driven by Koopman.			
Mile Trial for Track Record (0:59 2-5)			
Simplex		DePalma	:58 1-5
Five-Mile, Time Trial for Track Record (5:20)			
Simplex		DePalma	4:51 1-5

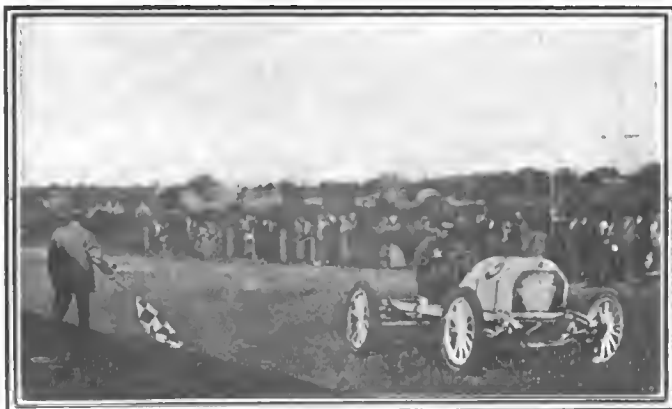

Paige-Detroit, No. 5, winning the five-mile race for small cars

### Truck Test at the Golden Gate

SAN FRANCISCO, Sept. 26—The first motor truck test projected in northern California is to take place here October 4-5. Already more than a score of big machines have been entered in the contest, and the greatest interest is displayed among the dealers who have truck interests. The White Company alone has entered five trucks.

The first day's run will be from San Francisco down the peninsula to San Jose and return, a total distance of a little under 100 miles. On the second day the cars will remain within the boundaries of the city. It does not appear that the test is going to be very strenuous, plenty of time being permitted for the San Jose run on the first day and for the distance to be negotiated on the following day.



## Inquest at Syracuse

SYRACUSE, N. Y., Oct. 4—The New York State Fair Commission, driver Lee Oldfield, the American Automobile Association, Referee A. R. Pardington and the crowd were held by the Coroner's jury to have been guilty of negligence at the inquest to-day in the matter of the recent terrible fatality at the State Fair track, when the Knox automobile driven by Oldfield crashed through the fence and killed eleven persons and injured nine. Nobody, however, was found sufficiently culpable to justify charges of manslaughter, and Oldfield, who had been under technical arrest, was released.

The evidence adduced showed a dispute between Lee Oldfield, the driver, who early this week had completely recovered from his injuries and left the hospital, and Manager Moross regarding the responsibility for his remaining in the race after it was known that his tire had gone bad. The tread of one of De Palma's Simplex tires had come off when the Italian was leading in the 50-mile race by a mile. Oldfield's testimony was to the effect that he was signaled to keep on in the hope that De Palma's tire would burn out and allow Oldfield to take the lead. Moross denied this, and said that Oldfield kept on on his own responsibility.

The evidence further showed police protection that might have been looked for at a half-mile track in the country districts. The policing was in charge of a clerk in a meat store. With 30 men assigned to him, he accounted for 14. The original plan had been to police the track with 125 regular and special police and with a militia detachment from this city. The militia-men left the grounds before the accident. The police that remained mostly mingled with the crowd, and with onlookers grabbed for souvenirs after a previous accident to Burman's Blitzen-Benz. A picture taken by an amateur photographer, just before the accident, showed the crowd encroaching upon the course at the fatal turn.

An important witness was A. R. Pardington, of The A. A. A., referee of the races. Mr. Pardington declared emphatically that he believed Lee Oldfield to be the right name of the responsible driver. Mr. Pardington said that if Lee Oldfield had perjured himself in taking out a license under a name not his own, that the fraud would have been discovered ere now and his license revoked. Mr. Pardington added that the reason the races were not stopped immediately was because to have done so would have been to precipitate a disastrous panic.

It is said on excellent authority that the surviving relatives of the deceased will soon bring actions for financial redress against the State.

## Track Racing for Columbia, S. C.

COLUMBIA, S. C., Oct. 2—Two days of automobile racing will be presented to automobile enthusiasts of this section on November 3-4, when the meeting promoted by the Automobile Club



Mercer leading the National in the free-for-all at Guttenberg

of Columbia is held at the State fair track. The affair has been fully sanctioned and purses aggregating \$1,325 hung up.

The races range from mile trials to 25-mile free-for-alls. No stock car races have been carded, the classes being C and D. A handsome piece of plate is offered for the mile trials. Entries close October 27.

## Local Mile Record Falls at Bridgeton

BRIDGETON, N. J., Oct. 2—The South Jersey mile record on a half-mile track was broken Saturday afternoon by a Kline (Morton), which made the double circuit in 1:15. The races were well contested and proved interesting despite the small fields. The stands and paddocks were fairly filled with 2,500 enthusiasts. The summary:

Car	Driver	Position	Time
Kline Hudson 20	Menker	1	7:30
	Luinney	2	
<b>Five-Mile Handicap</b>			
Kline Knox	Menker	1	6:37 4-5
	Dinapoli	2	
<b>Five-Mile Match</b>			
Mercer Kline	Ringler	1	6:34 3-5
	Morton	2	
<b>Five-Mile Match</b>			
Jackson Knox	Bloxton	1	7:18 1-5
	Dinapoli	2	
<b>Five-Mile Match</b>			
Mercer Kline	Ringler	1	6:38 1-5
	Morton	2	
<b>Five-Mile Handicap</b>			
Mercer Abbott	Ringler	1	6:50 3-5
	Padula	2	
<b>Mile Trials</b>			
Kline	Morton		1:15
Knox	Dinapoli		1:19
Kline	Menker		1:20



Start of the five-mile race at Guttenberg, for private owners, in which three Regal cars contested—won by No. 12, driven by Ira Vail

# Spaces Awarded at N. A. A. M. Shows

**N**EW YORK, Oct. 4—At the meeting of the N. A. A. M., held at the headquarters of the association this afternoon, positions were drawn for next winter's Chicago and Palace shows. Ninety-six makers drew for space at the Chicago pleasure car show, January 27 to February 10, of whom forty-seven were assigned places in the Coliseum, eighteen in the Coliseum basement, and thirty-one in the First Regiment Armory. The companies were divided into three general classes. The first of them was composed of members of the National Association of Automobile Manufacturers; the second, of members of the Automobile Board of Trade, who were not members of the National Association, and the third class included the independents.

The first class was divided into sections marked off by the amount of business the companies did, and the number of shows they participated in. Each class was exhausted before the next class was taken up. Space was awarded on that basis as follows:

**COLISEUM**—A1 Winton; A2 Rambler; A3 Franklin; A4 Buick; A5 Marmon; A6 E-M-F; B1 Woods; B2 Locomobile; B3 Lozier; B4 Hudson; B5 Reo; B6 Oldsmobile; C1 Packard; C2 Pierce-Arrow; C3 Stevens-Duryea; C4 Chalmers; C5 National; C6 Pope; D1 Maxwell; D2 Stoddard-Dayton; D3 Premier; D4 Cadillac; D5 Overland; D6 Peerless; E1 Brush; E2 Thomas; E3 Pullman; E4 Knox; F1 Columbia; F2 White; F3 Haynes; F4 Corbin; G1 Everitt; G2 Hupp; H1 Oakland; H2 Stearns; J1 Matheson; K1 Mitchell; L1 Abbott-Detroit; M1 Alco; N1 Cole; O1 Elmore; O2 Baker Electric; P1 Ohio Electric; Q1 American; Q2 Selden; Q3 Glide.

**FIRST REGIMENT ARMORY**—A1 Hupp Corporation; A2 Waverley; A3 Columbus; A4 Interstate; B1 Marquette; B2 Moline; B3 Rauch & Lang; B4 Case; C1 Garford; C2 Detroit Electric; C3 Simplex; C4 Cartcar; D1 Jackson; D2 Regal; D3 Austin; D4 DeTamble; E1 Kissel; E2 Staver; E3 Krit; E4 Cunningham; E5 Great Western; E6 Fiat; F1 Clark-Carter; F2 Imperial; G1 Babcock; G2 McIntyre; G3 Auburn; G4 Paterson; G5 McFarlan; G6 Moon; H1 Dorris.

**BASEMENT OF COLISEUM**—1 Stutz; 2 Elkhart; 3 Cino; 4 Borland; 5 Broc; 6 Halladay; 7 Warren-Detroit; 8 Zimmerman; 9 Michigan Buggy Co.; 10 Lion; 11 Buckeye; 12 Speedwell; 13 Ohio; 14 Marion; 15 Republic; 16 Paige-Detroit; 17 Crow; 18 Schacht.

Accessory spaces in the Coliseum number 135 and the M. & A. M. have contracted for all; besides there are several members over and above who have applied for space. In the gallery of the Armory there are 30 spaces to be divided among 70 applicants, not members of the organization. For the truck week the preliminary showing is so strong that already it has been determined to use both the Armory and the Coliseum for the commercial display.

The drawings for spaces in the commercial show, which is scheduled for the second week, are as follows:

**COLISEUM**—Section A, Baker, Rambler, Mack; Section B, Reo, Kelly, Pope, Rapid, Grabowsky; Section C, Franklin, Stearns, Cartcar, Waverley, Packard and Locomobile; Section D, Peerless, Brush, Gramm, Metzger, Knox; Section E, Alco, Detroit Electric, Schmidt; Section F, Kissel, Pierce-Arrow; Section G, Reliance; Section H, General Motors; Section J, Staver; Section K, Lozier; Section L, McIntyre; Section M, Avery; Section N, Rassel, Federal, Adams; Section O, Eclipse; Section P, Clark, Sampson; Section Q, Dorris, Dayton, Durant-Dart; United States Motors Company.

**FIRST REGIMENT ARMORY**—Section A, Stegeman, Walker; Section B, Packers, Smith, Coleridge, Lauth-Juergens; Section C,

Sternberg, Lee; Section D, National, Universal; Section F, Schacht.

The result of the drawings for space in the show at the new Grand Central Palace, January 10-17, follows:

**MAIN FLOOR**—Section A, Paterson, Velie, Ohio Electric, Imperial, Cutting, Waverley; Section B, Hupp Corporation; Section C, Paige-Detroit, Ames; Section D, Fiat, Cole; Section E, Marion, Stutz, Krit; Section F, Hupmobile, Warren-Detroit; Section G, Babcock Electric; Section J, KlineKar; Section K, Abbott-Detroit; Section L, Cino, Colby; Section M, Rambler, Regal, Schacht, Auburn, DeTamble; Section N, Lion, Middleby; Section O, Great Western, McFarland.

**SECOND FLOOR**—Section A, Elkhart, Crow. All the remainder of the exhibits on this floor are trucks, as follows: Gramm, Waverley, Schacht, Lauth-Juergens, National, Packers, Kelly, Durant-Dort, Eclipse, Universal; Section B, Sanford, Newark; Sections D and E, Atterbury; Section F, Walter, Dayton, Raffel; Section J, Sullivan, Lippard, Cortland.

The new Grand Central Palace is a giant structure, being bounded by Lexington avenue, Forty-sixth and Forty-seventh streets and Depew place. The floors that will be used for show purposes are the main, second and third. A court extends from the main floor to the ceiling of the third and the dome-like roof over this portion of the hall is supported by Corinthian columns of ornate structure.

The interior of the building is considerably cut up by pillars and it is problematical still how far this type of architecture will lend itself to automobile show purposes. But it is artistically beautiful. The pillars will not interfere with the showing of particular exhibits, because the space is ample and access from all sides will be easy, but it will be impossible to get any such general view of the display as is afforded by the arrangement of Madison Square Garden.

A grand stairway leads up to the main floor from the street level and the first impression of the hall is that of vastness. The rather low ceiling adds to this impression, paradoxical as that may seem. The pillars are in several styles, ranging from the Corinthians with their decorative capitals to square, business-like columns that are simply utilitarian.

The second floor is arranged around the court, with a large amount of space available on the Lexington avenue side, while there is still more room for exhibits on the third floor, due to the partial closing of the court. Each floor is approximately 194 by 268 feet, thus without making allowances for the court and various portions of each floor that are not available for show space, the total area of the three floors is 155,376 square feet. Probably 25,000 square feet should be deducted from this total to make allowance for space used otherwise than for show purposes.

The decorative scheme will be mosaic, but its details still remain to be worked out. Mr. Miles declares that any such scheme of decoration as has been used in many of the big shows of the past would seem like painting the lily, as applied to the palace. The ornamentation will undoubtedly be simple so that it will not detract from the architectural beauties of the building.

Some progress has been made in the details of the Madison Square Garden show, but the work is moving slowly. It is not likely that floor plans will be issued for several weeks. The Motor and Accessory Manufacturers have announced that about 150 of their members would show at the Garden during the week when the pleasure cars are on exhibition. Fully ninety M. A. M. members will show during the truck week at the Garden.

# Automobile Aids Carriage Builders

ATLANTIC CITY, N. J., Sept. 30—The thirty-ninth annual convention and exhibition of the Carriage Builders' National Association were held on Young's Million Dollar Pier during the past week, the exhibition extending throughout the entire week, from Monday to Friday, inclusive, and the convention proper covering a period of two days, Tuesday and Wednesday, when the regular business of the association was taken up and officers elected for the ensuing three years. Delegates were present from all over the country and the industry was shown to be in a flourishing condition, despite the inroads made by the horseless vehicle. Rather, as E. C. Mulcey, of Philadelphia, in an address on "Electricity as Related to the Vehicle Industry" said, the use of the automobile has broadened the scope of the wagon and carriage builders' art and brought to carriage and wagon manufacturers new fields for the sale of their product, and suggested the amalgamation of wagon and carriage builders with experts on engines, electric motors, storage batteries, etc., to their mutual advantage. Disclaiming the idea that the automobile was a competitor opposed to the vehicle builder's interest he asserted that the former was strictly a branch of vehicle building and a development of that art brought about by the demands of modern times.

President Charles J. Richter's address to the delegates on Tuesday dealt with the future of the carriage and during the course of his remarks he said that although the carriage has been largely superseded by the horseless vehicle in the large centers of population, there is still a steady demand for the horse-drawn carriage, and claimed the light horse-drawn pleasure carriage will always have its devotees.

The consensus of opinion among the speakers was to the effect that automobile manufacturers and wagon and carriage builders should work together, their interests being identical in many respects.

Headquarters of the convention while in Atlantic City were established at the Marlborough-Blenheim, where also the annual banquet was held.

The following officers were elected: President, William H. McCurdy, Evansville, Ind.

Secretary-Treasurer, Henry C. McLear.

Trustee of Technical School, William R. Innes, New York.

Executive Committee, Charles C. Hull, Connerville, Ind.; Charles H. Lancaster, Merrimac; George A. Brockway, Homer, N. Y.; C. O. Wrenn, Norfolk, Va.; W. A. Sayres, Cincinnati, O.

In number and variety of exhibits of vehicle parts the exhibition was up to previous shows and the attendance excellent.

The following manufacturers and jobbers of automobile accessories were represented at the exhibition and had displays:

American Tire Drill Company, Cincinnati, O.—Motor-driven and belt driven tire drilling machines.

Backstay Machine & Leather Company, Union City, Ind.—"Never-Burst" wire-bound prop blocks, patent valances for stitching on tops, patent auto top tack valance, auto straps, etc.

D. W. Byron & Sons, Williamsport, Ind.—Leather for automobile, carriage and furniture manufacturers.

W. H. Coe Manufacturing Company, Providence, R. I.—Coe's ribbon gold leaf and gilding wheels, for striping, lettering and decorating automobiles, carriages and wagons.

Consolidated Rubber Tire Company, New York City—Kelly-Springfield sectional truck tires and solid carriage tires.

Cortland Forging Company, Cortland, N. Y.—Auto top and buggy forgings.

Crandal, Stone & Company, Binghamton, N. Y.—Bow sockets and top hardware for automobiles and carriages.

Ditzler Color Company, Detroit, Mich.—Automobile, coach and car colors.

Dusenbury, Louis & Company, Inc., New York—Automobile and carriage upholstery, automobile top fabrics, etc.

Eberhard Manufacturing Company, Cleveland, O.—Automobile, carriage and wagon hardware.

Eccles Company, Auburn, N. Y.—Automobile forgings, etc.

Enterprise Brass & Plating Company, Cincinnati, O.—Robe rails, dash rails, arm rails, handles.

Excelsior Seat Company, Columbus, O.—Automobile seats, runabout seats, etc.

Fabrikoid Works, E. I. duPont de Nemours Powder Company, Newburgh, N. Y.—Artificial leather and automobile top goods.

Fairfield Rubber Company, Fairfield, Conn.—Full line of automobile and carriage cloths.

Herbrand Company, Fremont, O.—Automobile wrenches, etc.

Goodyear Tire & Rubber Company, Akron, O.—Wing and eccentric cavity cushion tire rubber.

Gramm Motor Truck Company, Lima, O.—Five-ton chassis, three-ton chassis, etc.

Liggett, Spring & Axle Company, Pittsburgh, Pa.—Automobile springs and axles, brass fittings for automobiles.

Metal Stamping Company, Long Island City, N. Y.—Automobile trimmings and hardware, etc.

Mohawk Valley Manufacturing Company, Utica, N. Y.—Automobile mufflers, etc.

Muncie Wheel Company, Muncie, Ind.—Automobile wheels, etc.

Rogers & Company, Inc., Philadelphia, Pa.—Limousine and touring car trimmings, brass goods, etc.

Rose Manufacturing Company, Philadelphia, Pa.—Neverout lamps.

Sheldon Axle Company, Wilkes-Barre, Pa.—Axles and springs for power-propelled and horse-drawn vehicles.

Smith & Company, New York—Automobile and carriage color varnishes, etc.

Standard Varnish Works, New York and Chicago—Quick finishes for automobile and carriage bodies.

Swinehart Tire & Rubber Company, Akron, O.—Motor buggy tires, clincher and flange truck tires, etc.

Western Spring & Axle Company, Cincinnati, O.—Comprehensive line of springs and axles for both auto and horse-drawn vehicles.

Woll & Sons Manufacturing Company, Philadelphia, Pa.—All grades of curled hair for automobile and carriage upholstery.

## Big Plans for Hartford Show

HARTFORD, CONN., Oct. 2—The Automobile Club of Hartford has decided to hold its 1912 show February 19 to 24, in the new state Armory, which has a larger floor area than Madison Square Garden. The main floor of the big hall gives an area of over 50,000 square feet for the exhibit of cars and accessories, while there are numerous side rooms, drill rooms, etc., which bring the total available space to practically 65,000 square feet.

The tentative decoration plans call for a big outlay of money. To place the sky bunting over the vast iron-girded ceiling will cost alone about \$1,000. The whole hall will be profusely decorated. The outlay of the spaces call for a wide aisle on the four sides of each exhibit.

The work on the show has already started under the direction of Fred W. Dart and E. G. Biddle, and as soon as the sanction is received the plans will be rapidly pushed ahead.

## Fairmount 200-mile



Showing the wide and level home stretch, with stands on either side



First turn after leaving the start—grandstand in the distance



At the top of the sinuous Sweetbrier Hill—note large direction signs



Half-way down Sweetbrier Hill, the most dangerous place on the course

PHILADELPHIA, Oct. 3—The entry list of the Fairmount Park road race closed at midnight last night and although the total falls eleven shy of the limit set by the Contest Committee of the Quaker City Motor Club, and thirteen below the number participating last year, the contest is expected to be none the less thrilling on that account and indications point to all attendance records being broken. There are nineteen cars entered, representative of eleven separate makes.

Five last-minute entries were made yesterday: two Bergdolls, an Ohio, a Mercedes and a Fiat.

Preliminary practice trials are being held each morning between sunrise and 7.30, twelve drivers having had their cars out this morning, quite a large crowd being present to look on. A heavy rain put a quietus on the spins Monday morning, the track being very soft, and although five drivers were on the ground, none ventured the heavy going. These trials will continue every morning until the day of the race.

The race long since ceased to be strictly a local affair, and visitors are expected from not only all over Pennsylvania, but from many of the adjoining States as well. Of course, there is no way by which an accurate count could be made of the thousands upon thousands that line both sides of the 8-mile course from one end to the other and that storm the turns where thrills may be expected, but putting last year's attendance at approximately 500,000, judging by the increasing interest this classic takes on yearly, it is not overstating the facts to say that 750,000 will see next Saturday's race.

Reserved seats and boxes have been eagerly snapped up almost as soon as placed on sale and the advance demand for parking spaces has been unprecedented. Proceeds of the race are divided equally between several of the city's charitable and philanthropic institutions.

Police regulations governing the course will, as in former years, be adequate, the number of guardians on duty numbering at least 2,000. Officers will be stationed about 20 feet apart, with an augmented guard at the turns. At points regarded as dangerous and at particularly sharp curves, the rule keeping spectators at a safe distance from the road, in some instances from 25 to 50 feet back, will be strictly enforced.

Regarding the race itself, many old favorites will be seen, with a liberal sprinkling of drivers who have become famous on other tracks. But there is an additional curiosity attached to the veterans of other Fairmount Park races this year in that few of them will be identified with the cars with which it has become the habit of associating them.

Thus, Len Zengel, who piloted a Chadwick to victory last year in the closest race ever witnessed here, will be at the wheel of a National. Ralph Mulford, the runner-up last fall, will as then drive a Lozier, but rumor has it that he will be found at the wheel of another make before long. Harry Grant, twice winner of the Vanderbilt cup, will also drive a Lozier, with which car he has been identified since the American Locomotive Company dropped racing. Erwin Bergdoll is about the only other driver who will use the same car, he having again nominated the Benz. Newcomers include Charles Basle, Cole; Lee Oldfield, Fiat; Joe Jagersburger, Case; Gil Anderson, Stutz; Harvey Ringler and Hughie Hughes, each driving a Mercer, and many others.

Cars will run in five classes, divisions 2-C, 3-C, 4-C, 5-C and 6-C, a prize of \$1,000 is hung up in each, with a grand prize of \$2,500 for the car making the best time. In addition this year prizes of cash will be awarded by the Remy Magneto Company to the first, second and third cars, Remy-equipped, in the

# Will Draw Big Crowd

various divisions. Findeisen & Kropf, on behalf of the Rayfield carbureter, have offered \$200 in each of the classes for winning cars carrying Rayfield carbureters.

Contest will start at 12 o'clock noon. The course covers about 8 miles, the start and finish being at Memorial Hall, around Sweetbrier Hill, north on the West River Drive, to city line, to Belmont avenue, to start.

The complete classified list of entries is as follows:

Division 3-C—231 to 300 Cubic Inches Piston Displacement					
Car.	Bore.	Stroke.	Entrant:	Driver.	
Ohio	4 15/32	4 1/4	Ohio Motor Car Co.	S. H. Matthews	
Ohio	4 15/32	4 1/4	Ohio Motor Car Co.	George P. Parker	
Cole	4 1/2	4 1/2	Cole Motor Car Co.	Charles Basle	
Mercer	4 3/4	5	Mercer Automobile Co.	Harvey Ringler	
Mercer	4 3/4	5	Mercer Automobile Co.	Hughie Hughes	
Case	4 3/4	5	Case T. M. Co.	Joe Jagersberger	
Bergdoll	4	5 15/16	Grover Bergdoll	Grover Bergdoll	
Bergdoll	4	5 15/16	Charles Bergdoll	Charles Bergdoll	
Division 4-C—301 to 450 Cubic Inches Piston Displacement					
National	5	5 11/16	Weldon & Bauer	Harry Koopman	
National	5	5 11/16	Tioga Automobile Co.	Donald Herr	
Stutz	4 3/4	5 1/2	Ideal Motor Car Co.	Gilbert Anderson	
Division 5-C—451 to 600 Cubic Inches Piston Displacement					
Lozier	5 3/4	6	Lozier Motor Co.	Ralph Mulford	
Lozier	5 3/4	6	Dr. W. H. Chambers	Harry Grant	
Mercedes	5.1	7.1	Boulevard Garage	Spencer Wishart	
National	5	7 1/4	National Mot. Veh. Co.	Len Zengel	
Mercedes	130mm.	132-135mm.	Ed. J. Schroeder	Willie Wallace	
Division 6-C—601 to 750 Cubic Inches Piston Displacement					
Fiat	130mm.	190 mm	J. Fred Betz, 3d.	J. Fred Betz, 3d.	
Benz	155mm.	160mm.	Erwin R. Bergdoll	Erwin R. Bergdoll	
Fiat	130mm.	190mm.	Frank S. Hodson	Lee Oldfield	

## L. I. A. C. to Attend Fairmount Race

BROOKLYN, N. Y., Oct. 2—Extraordinary preparations are being made by the Long Island Automobile Club to attend the forthcoming road race at Fairmount Park, Philadelphia. The club has arranged for a special train over the Central Railroad of New Jersey, leaving New York at 8:50 o'clock in the morning, October 7, and reaching the park at 11:15. Present indications point to a delegation of at least 100. Accommodations in one of the grandstands are the subject of negotiations, and if these are secured the Brooklyn party will be kept together during the running of the race.

The return trip will be from the Reading terminal at 7 o'clock, and the train is scheduled to arrive in New York at 9 o'clock.

## Massaging Grand Prix Course

SAVANNAH, GA., Oct. 2—Work on the course to be used for the four big road races next month is progressing satisfactorily. The new paving which joins Norwood and La Roche avenues and upon La Roche avenue to Dale avenue and through the latter to Waters road has been completed. Waters road will probably be finished in two weeks and the rest of the circuit will then be taken in hand.

Whitfield, Ferguson and Norwood avenues constitute the bulk of the uncompleted work, but the whole course should be finished and in better condition than ever before by November 5.

Some of the drivers who will take part in one or more of the races are as follows: Bruce-Brown, Parker, Tetzlaff, Nazarro, Bragg, Hemery, Burman, DePalma, Knipper and Hearne.

The Fiat company will have a team of five; the Benz company, three; Cole, three, and various other companies will be represented by from one to four cars. Definite formal entries for the events are not numerous so far.

It is estimated that there will be about eight cars in each of the light car races and twenty-five cars in the Vanderbilt Cup. The Grand Prix estimate is placed at twenty cars.



At the foot of Sweetbrier Hill—making the turn into the West River Drive



West River Drive, with bridge spanning roadway and Schuylkill



52d Street entrance, where course leaves Park and follows a city street



Stretching the ropes with the aid of a hose reel drawn by an Autocar truck



# Glidden Tour to Have 83 Starters

WITH a total list of 83 cars, the Glidden Tour of 1911 will start on its journey Saturday morning, October 14, from a point on Fifth avenue, probably in front of the new public library. There will be 73 cars in the contesting column, but the make-up of the various teams has not been crystallized so far.

The main trophy will be awarded to the team with the least number of demerits at the conclusion of the tour and penalties will only be imposed for lateness at controls. The daily schedules are easy as far as mileage is concerned, and but for bad weather it would appear that a large number of clean scores must result. However, no allowance will be made for tire troubles and in case of bad roads aggravated by bad weather the clean score list will be reduced materially.

The complete entry list is as follows:

Entrant	City	Car
C. S. Winn	Atlanta	1912 Flanders
John S. Coben	Atlanta	1912 White
J. H. Marsteller	Roanoke	1910 Chalmers
C. S. Nolan	Jacksonville	1912 Cadillac
U. S. Motor Co.	Tarrytown	1912 Maxwell
U. S. Motor Co.	Tarrytown	1912 Maxwell
U. S. Motor Co.	Tarrytown	1912 Maxwell
E. F. Ansley	Atlanta	1911 Pierce-Arrow
C. H. Johnson	Atlanta	1912 Stevens-Duryea
H. M. Grant	Atlanta	1911 Marmon
H. B. Race	Jacksonville	1910 Cole
W. J. Hillman	Live Oak	1912 Cadillac
W. E. Aycock	Moultrie	1910 Knox
J. R. Sandlin	Jasper	1912 Cadillac
R. D. Drysdale	Jacksonville	1911 Cadillac
Hoke Smith	Atlanta	1912 Maxwell
Studebaker Corp.	Detroit	1912 Flanders
Studebaker Corp.	Detroit	1912 Flanders
Studebaker Corp.	Detroit	1912 Flanders
C. J. Hood	Commerce	1911 Columbia
Frank Hardart	Philadelphia	1911 Winton
H. M. Atkinson	Atlanta	1908 Packard
William D. Alexander	Atlanta	1911 White
D. H. McMillan	Jacksonville	1912 Cadillac
Inman Gray	Atlanta	1911 American Traveler
James R. Gray	Atlanta	Thomas Rambler
Henry Tift	Tifton	
Streator M. C. Co.	Albany, Ga.	1911 Halladay
C. E. Fryer	Albany, Ga.	1911 Halladay
D. P. De Berry	Albany, Ga.	1911 Halladay
Metz Company	Waltham, Mass.	1912 Metz
Metz Company	Waltham, Mass.	1912 Metz
Metz Company	Waltham, Mass.	1912 Metz
Crawford Wheatley	Americus, Ga.	1912 Stevens-Duryea
Anderson Ad Club	Anderson, S. C.	1912 Mitchell
Atlanta Ad Club	Atlanta	1912 Corbin
R. S. Hall	Ocala, Fla.	1912 Cadillac
J. Epps Brown	Atlanta	1911 Thomas
H. P. McNeil	Jacksonville	1912 Cadillac
St. E. Massengale	Atlanta	1912 Garford
Griffith Imp. Co.	Athens, Ga.	1912 Schacht
L. C. Brown	Athens, Ga.	1912 Mitchell
P. D. Sandlin	Jasper, Fla.	1912 Cadillac
Bishop and Varner	Athens	1912 Maxwell Mercury
Jacksonville Metropolis	Jacksonville	1912 White
L. C. Denmark	Jacksonville	1912 Cadillac
R. S. King	Arcadia, Fla.	1912 Cadillac
Carolina Port, Cem. Co.	Atlanta	1911 Ford
E. M. Willingham	Atlanta	1912 Ford
I. O. Teasley	Alpharetta, Ga.	1912 Ford
C. M. McCardle	Indianapolis	1911 E-M-F
Athens M. C. Co.	Athens	1911 Columbia
J. H. Drennan	Newark, N. J.	1912 Packard
J. S. Sbingler	Ashburn, Ga.	Cadillac

Entrant	City	Car
Martin and Rees	Habira, Ga.	Cadillac
Winston-Salem B. of T.	Winston-Salem	Mitchell
Cordele, Ga.	Cordele	Oldsmobile
Cordele C. of C.	Cordele	Oldsmobile
Joseph M. Downing	Nashville, Tenn.	Marathon
R. L. Dozier	Nashville, Tenn.	Marathon
Vernon Hutton	Nashville, Tenn.	Marathon
Board of Trade	Decatur, Ga.	Flanders
E. Rivers	Atlanta	Pierce-Arrow
W. N. Stinson	Jacksonville	Oldsmobile
E-M-F-Atlanta Co.	Atlanta	Flanders
Brooks Morgan	Atlanta	Stevens-Duryea
Asa G. Candler, Jr.	Atlanta	Lozier
Roberts Motor Co.	Jacksonville	Flanders
I. M. Powell	Cordele	Oldsmobile
Krit M. C. Co.	Detroit	Krit
Lindsey Hopkins	Greensboro, N. C.	Overland
Chamber of Commerce	Greensboro	Case
A. H. Whiting	New York	1912 Cunningham (Pacemaker)
Ray M. Owen	New York	1912 Reo (Official car)
Ray M. Owen	New York	1912 Reo (Official)
Vellie M. V. Co.	Atlanta	1912 Vellie (Press car)
R. M. Owen	New York	Reo Truck (Baggage)
Cbalmers M. Co.	Detroit	Cbalmers Six (Press car)
C. W. Kelsey Mfg. Co.	Hartford	Motorette (Non-contest.)
C. W. Kelsey Mfg. Co.	Hartford	Motorette (Non-contest.)
C. W. Kelsey Mfg. Co.	Hartford	Motorette (Non-contest.)

## Buckeye Suggests Good Roads Plan

COLUMBUS, OHIO, Oct. 2.—State Highway Commissioner James R. Marker advocates co-operation on the part of the State and Federal Government as the best means to secure good roads.

He favors making provision in the coming constitutional convention for authority by the State to issue bonds to the amount of \$5,000,000 annually. Such an outlay within fifteen years would give the State a perfect system of roads.

Commissioner Marker contends it would be far more beneficial for the Federal Government to put its spare millions into good roads instead of dumping it into the army and navy. In Ohio there are 90,000 miles of highway, 50,000 miles of rural free delivery and 8,000 miles of roads which would fit into an inter-county system.

## Garford Train Starts to Los Angeles

Equipped for a transcontinental tour, four Garford touring cars and a baggage truck started from New York on Monday, headed for Los Angeles. These cars were joined at Albany Tuesday by a fifth touring car which started from Boston. When the party has progressed westward as far as Cleveland, another baggage truck will join the caravan. There are twenty-five passengers riding on this automobile train.

According to schedule, the train will reach Los Angeles in 51 days. The rate of fare is \$875, which averages \$16 a day covering everything. Raymond & Whitcomb are responsible for the venture. A. L. Westgard is in charge.

### DAILY ITINERARY OF THE GLIDDEN TOUR OF 1911

A.M.	Start.	Noon Stop.	Mileage to Noon Stop.	Night Stop.	Daily Mileage.	P.M.
Oct. 14	New York	Trenton		Philadelphia	95.1	Oct. 14 Sat.
Oct. 15	Philadelphia	Lancaster	66.4	Gettysburg	120.1	Oct. 15 Sun.
Oct. 16	Gettysburg	Winchester	88.3	Staunton	182.3	Oct. 16 Mon.
Oct. 17	Staunton	National Bridge	52.1	Roanoke	90.8	Oct. 17 Tues.
Oct. 18	Roanoke	Martinsville	60.9	Winston-Salem	124.3	Oct. 18 Wed.
Oct. 19	Winston-Salem	Salisbury	89.6	Charlotte	135.6	Oct. 19 Thur.
Oct. 20	Charlotte	Spartansburg	90.7	Anderson	160.6	Oct. 20 Fri.
Oct. 21	Anderson	Commerce	64.3	Atlanta	144.2	Oct. 21 Sat.
Oct. 22	Atlanta		(Sunday stop-over)			
Oct. 23	Atlanta		(Monday stop-over)			
Oct. 24	Atlanta	Macon	103.3	Cordele	167.5	Oct. 24 Tues.
Oct. 25	Cordele	Valdosta	90.2	Live Oak	149.1	Oct. 25 Wed.
Oct. 26	Live Oak	(none)		Jacksonville	85.0	Oct. 26 Thur.
Total mileage, 1454.6						

## Late Trade and General News

**C**HICAGO, Oct. 2—Sidney S. Meyers, chairman of the creditors' committee of the Maytag-Mason Motor Co., Waterloo, Iowa, has issued a statement to the creditors, requesting them to submit proof of debts to said company, so that the affairs of the company and the interest of the creditors can be placed within the jurisdiction of the United States district court.

This creditors' committee, appointed to investigate, found on July 1 assets, plant, equipment, merchandise, and all other ascertained assets to the extent of \$331,000. At that date the direct liabilities on bills and accounts payable were \$367,978.08. Contingent claims alleged to be due for breach of contracts and for other causes amounted to \$70,000, making a grand total of liabilities of \$437,978.08. Two-thirds of the actual assets are represented by unfinished motor car parts. It is estimated that the shrinkage in the value of these parts will be two-thirds of the book value.

There has been submitted by the company a tentative proposition of 33 1-3 per cent. for the unsecured claims, provided there shall be concluded a contemplated arrangement with Senator Maytag by which he shall take care of the secured claims.

### Colonels Win Lamp-Sign Fight

**LOUISVILLE, Oct. 2**—On motion of A. Scott Bullitt, County Attorney, the cases against Louisville motorists, charged with violating section 4 of the State automobile law, requiring that the number of the State license be displayed on the lamps of the cars, were dismissed Thursday in Magistrate Vogt's court. Mr. Bullitt declared that, inasmuch as the Secretary of State had informed members of the Louisville Automobile Club that they need not observe that section of the law, and as no subsequent warning had been given the owners of motor cars, all cases should be dismissed.

The executive committee of the Louisville Automobile Club met before the court and made preparations for the cases. Resolutions were adopted which provided for the making of a case to test the validity of the law.

### International Show in Berlin

**BERLIN, Sept. 24**—The first automobile show in Germany for 4 years will open in Berlin on October 12 and continue for 10 days. The show will be held under the auspices of the Imperial Automobile Club. The motor industry of eight countries—France, Germany, England, Belgium, Sweden, Switzerland, Italy and the United States—will be represented on the floor of the big exhibition pavilion.

More than 270 exhibitors have taken space and 67 factories will have cars on view; almost every model and type of car, both pleasure and truck, will be shown.

### Mud Stalls Winnipeg Contestants

**WINNIPEG, Oct. 2**—Over 200 miles of road, saturated with rain and buried in mud, the fourth annual contest for the Oldsmobile Endurance trophy was run last week. In addition to this amount of rough going the route contained another 200 miles of pretty passable thoroughfare. The run was commenced Wednesday morning and while its completion was scheduled for the following night, some of the cars have not arrived back in the city.

The award of the judges will not be made until the technical

inspection is completed this week. The cars returned in the following order: Ford, Paterson, Reo, Velie, Halladay, Empire, Chalmers and Hupmobile. The unaccounted cars are: Reo, Whiting and Halladay.

A. C. Emmett was pathfinder and Dr. F. W. Glasgow, judge.

### Hoosiers Choose Their Directors

**INDIANAPOLIS, Oct. 2**—Directors of the newly organized Hoosier Motor Club, were elected at a meeting held at the Claypool Hotel in Indianapolis, on the night of September 30. Officers are to be elected on the evening of October 5, and temporary club rooms will be established in the Claypool Hotel. Directors of the new club are Charles A. Bookwalter of the Mais Motor Truck Company; H. H. Rice, of the Nordyke & Marmont Company; Charles W. Sedwick; H. O. Smith, president of the Premier Motor Manufacturing Company; Bert A. Boyd; C. L. Diers, of the Goodyear Rubber Company; Joseph W. Selvage, Homer McKee and Hiram Brown. There are about thirty-five charter members.

### Harking Back a Decade

**I**N the issue of October 3, 1901, of *The Motor Review*, the following items were given prominence:

The First Annual Automobile Exhibition, under the auspices of the Chicago Automobile Club and the National Association of Automobile Manufacturers has been definitely fixed for March 1-8, 1902, at the Coliseum. This event will be the third automobile show to be held in Chicago.

Announcement is made that the E. R. Thomas Motor Company, of Buffalo, has disposed of its motorcycle business to the Auto-Bi Company. The latter agree to use Thomas motors for its product. E. L. Ferguson is named as sales manager.

The annual meeting of the N. A. A. M. is set for November during the Madison Square Garden show.

Washington, D. C., Sept. 28, 1901—The first call for bids to furnish motor vehicles to the postal service has been made. The subject matter of the proposals was the equipment of the Minneapolis department with five 1,000-pound wagons.

According to an executive order of the Secretary of the Treasury, exports of automobiles will be made a separate head in the monthly reports of exports. Such exports have been included under the general heading, "all other carriages."

At the Fort Erie race meeting Henri Fournier in a Mors car broke the world's record for 25 miles on a circular dirt track, making the distance in 31:58 2-5. He also broke the mile record, flying start, in 1:13 1-4.

The Lane Motor Vehicle Company, of Poughkeepsie, N. Y., sent a letter of protest to the editor, objecting to the reports of the New York-Buffalo endurance test on the ground that they did not go into mechanical details.

Bad roads are the subject of the leading editorial of the week and the experience of entrants on the endurance run is cited as an example of their condition in New York State. The roads beyond Albany are referred to as swamps.

C. C. Bramwell, in the feature article of the week, tells of the lessons to be learned from the endurance run. He said that the roads were worse than expected and blamed their condition on the farmer. He also calls attention to the practice of allowing manufacturers to enter as many cars as they please to the detriment of some of the smaller concerns that can enter but one or two cars.

# Berkshire Hills in Autumn Splendor

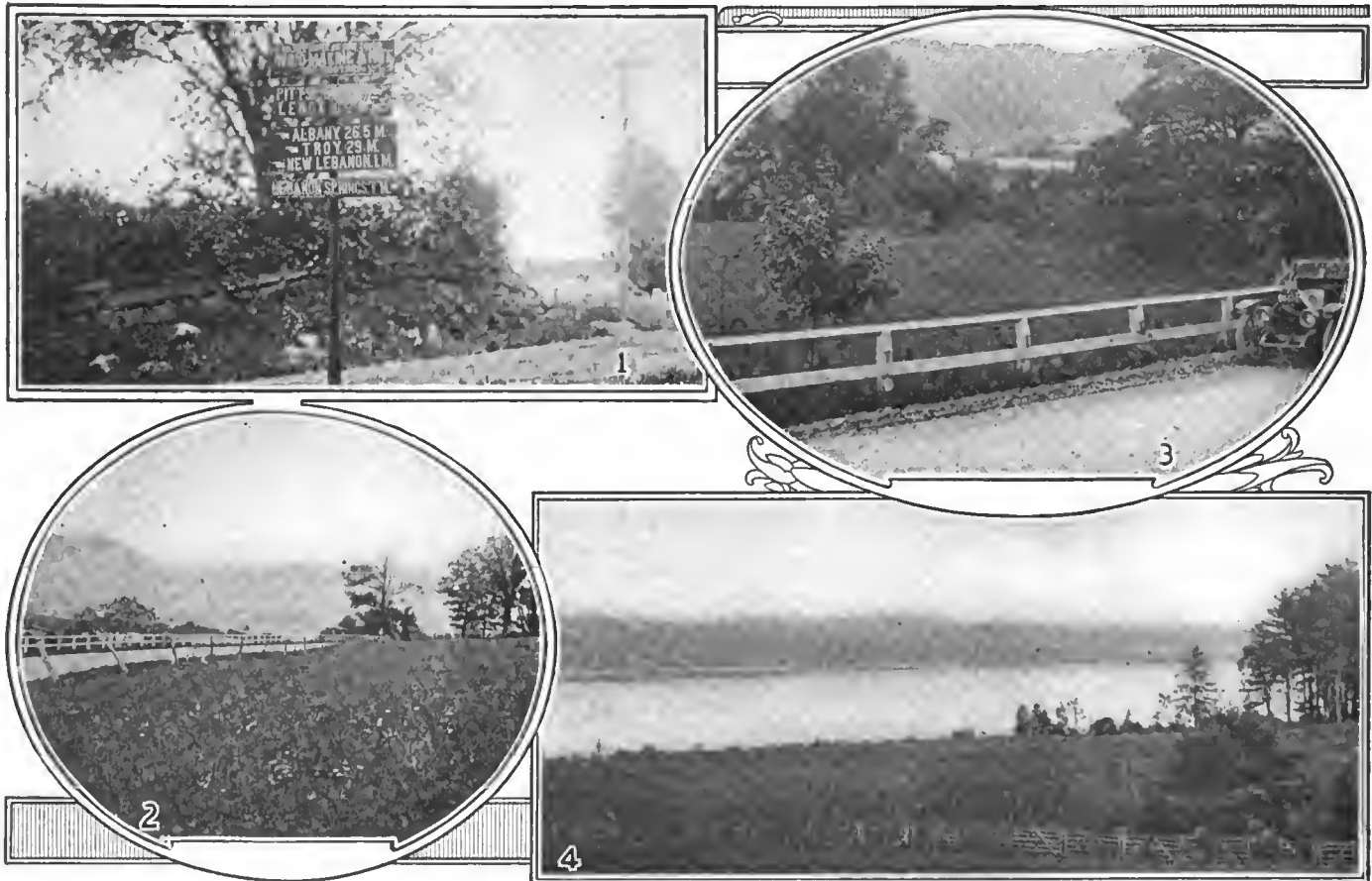

1—Comprehensive road signs are scattered along where needed

2—Road over Lebanon Mountain, just east of Massachusetts line

3—Just a glimpse toward the southern hills from Pittsfield

4—A shimmering lake, high in the hills near Lenox

“WHEN the frost is on the punkin” there is no more beautiful section of the globe than the Berkshire Hills of Massachusetts.

Jack Frost, the master painter, does his inimitable work with the delicate hand of the artist. He avoids the bold line-work of the impressionistic school without losing an atom of its coloration. He selects a single tree, set in a galaxy of green, and in one night converts it from tender, verdant greenery into a blazing focus for the center of his picture, lighting up a whole mountainside with the brilliant yellows and glowing reds and touches here and there a spot with his Autumnal pigments to make the contrast more inspiring.

Long before the valleys and low-lying sections feel the breath of frost the Berkshires are aglow with brilliance like unto nothing to be met with elsewhere.

A leisurely trip through this section, using an automobile for conveyance, so that one may select his own points of view and loiter along if he so wishes, will repay whatever it costs a thousandfold.

There is everything to be found along the way in the whole category of scenery. From some of the hilltops the giant vistas through the rich valleys deserve the inspired efforts of the poet; the rugged mountains, softened here and there where the pine trees have smoothed out the harshness of their granite walls, are marvelously virile despite their miniature size as compared with the towering peaks and bleak aspect of the Sierras and Rockies; the little lakes and streams, clear as crystal, tumble

noisily toward the ultimate ocean and lend a delightful variation to the picture panorama unfolded before the appreciative sight of the tourist; and the long, winding grades that lead to the lower levels complete the scene that has no equal in this part of the continent, if it has anywhere.

As the stage setting for an autumn honeymoon en automobile, the Berkshires are ideal. As a restful trip for the family, there is nothing like it to be found hereabouts. As a short respite for the businessman, it has everything that is necessary.

Given a good car, harmonious party and the present delightful first scene in the annual Indian Summer, and the perfect roads of New York and Massachusetts will do the rest.

Starting from Albany, full details of the course having been received from the Albany branch of the Touring Club of America, which is located in spacious quarters in the Hotel Ten Eyck, the party proceeds eastward, crossing the river and heads for the blue foot-hills. There are a number of pretty detours that may be made before reaching Lebanon Mountain, which is close to the Massachusetts State line, but these are not important unless the party wishes to spend a comparatively long time in the tour.

Climbing Lebanon Mountain is a delight, long to be remembered if the new state road that skirts the hillside is used in making the ascent. The grade is stiff, but not unduly trying to any modern automobile. At the crest of the road, the party passes into Massachusetts. The transition is not marked by any radical change in road conditions, for where one state leaves

# Offer Unusual Touring Opportunities

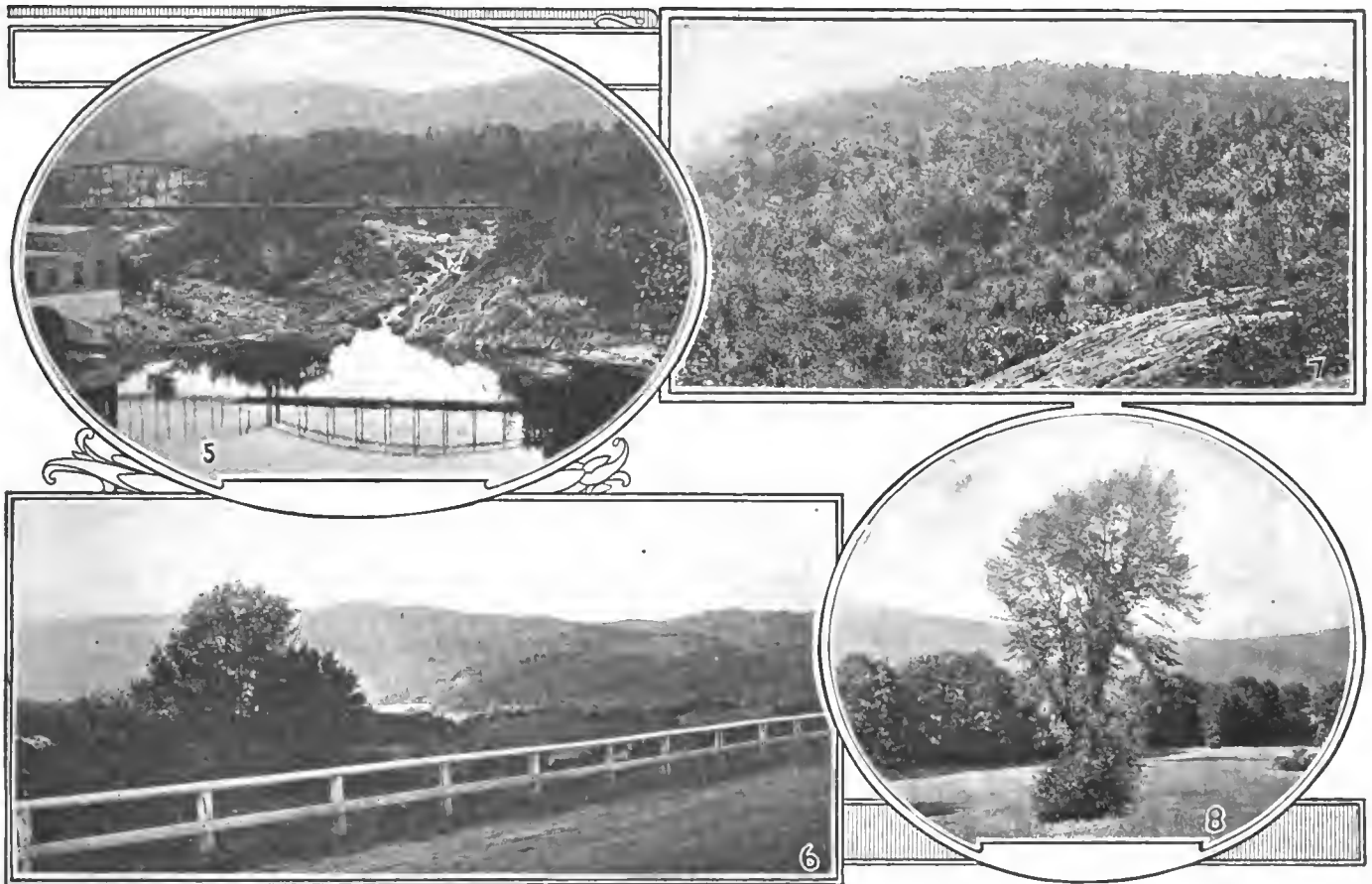

5—Spidery bridges give an Alpine tinge to the landscape

6—Varied scene typical of the section near Stockbridge

7—Granite ribs of the earth's body occasionally protrude

8—Greensward, hill and dale, on the way toward Pittsfield

off, the other picks up the work on similar lines and unless one noticed the signs that proclaim the state lines, the passage from one to the other would not be noticed.

From this point eastward lie the Berkshires and the run from Lebanon Mountain to Pittsfield is one of continuous beauty and change. It is only a short run in miles from Albany to Pittsfield, but it should be long in time because it deserves it. Fast time can be made for the roads are very perfect and magnificently kept, but it would almost seem like sacrilege to open up the throttle and miss a single picture.

Further details as to detours and lovely side trips are available at the Pittsfield quarters of the Touring Club of America at the Hotel Wendell. Of course, one wants to go over the celebrated Jacob's Ladder where only a few years ago a whole Glidden Tour stalled helplessly on the hillside. Most of the rungs have been pulled out of the ladder as it stands at present and the grades will not puzzle the average car in the least. Looking back at the old road over which the Glidden cars eventually passed, the impression of a ladder rising to heaven is not hard to receive. The old road has been eliminated by carrying the main highway around the other side of the hill and bringing it down to the grade of the state road at an easier angle.

The average tourist would pass by the old ladder if he were not watching for it. To-day it seems like an abandoned road through the woods, overgrown with underbrush and almost pathetic in its isolation.

The summit is reached just beyond this point and is decked

with a monument around which are piled stones bearing the names and addresses of automobilists from every section of the land who have contributed more or less ornamental memorials to the monument.

From there clear to Springfield the way is general down grade and a slow, deliberate automobile trip will reveal more beauties to the mile than the vast majority of tourists even suspect of existence.

There is another station of the Touring Club of America at Springfield, located in the New Kimball, where road information for a continuance of the tour may be had freely. Connecticut affords a big and beautiful field; the northern central portion of Massachusetts is historic in interest and gorgeous in Autumn colors and dozens of other sections stand ready for exploration.

Just one word of repeated caution. Take your time, enjoy Nature in her most wonderful garb and when you get home again you will have an evergreen memory that contains nothing but delight.

## Boost Good Roads with Bond Issues

SAN FRANCISCO, Sept. 26—The people of Glenn County, in northern California, have shown their appreciation of the benefits of good roads by voting road bonds to the amount of \$450,000, by a large majority of ballots. The bonds will be used for the building and improvement of 158 miles of roadway throughout the county, which is one of the smaller divisions of the State.

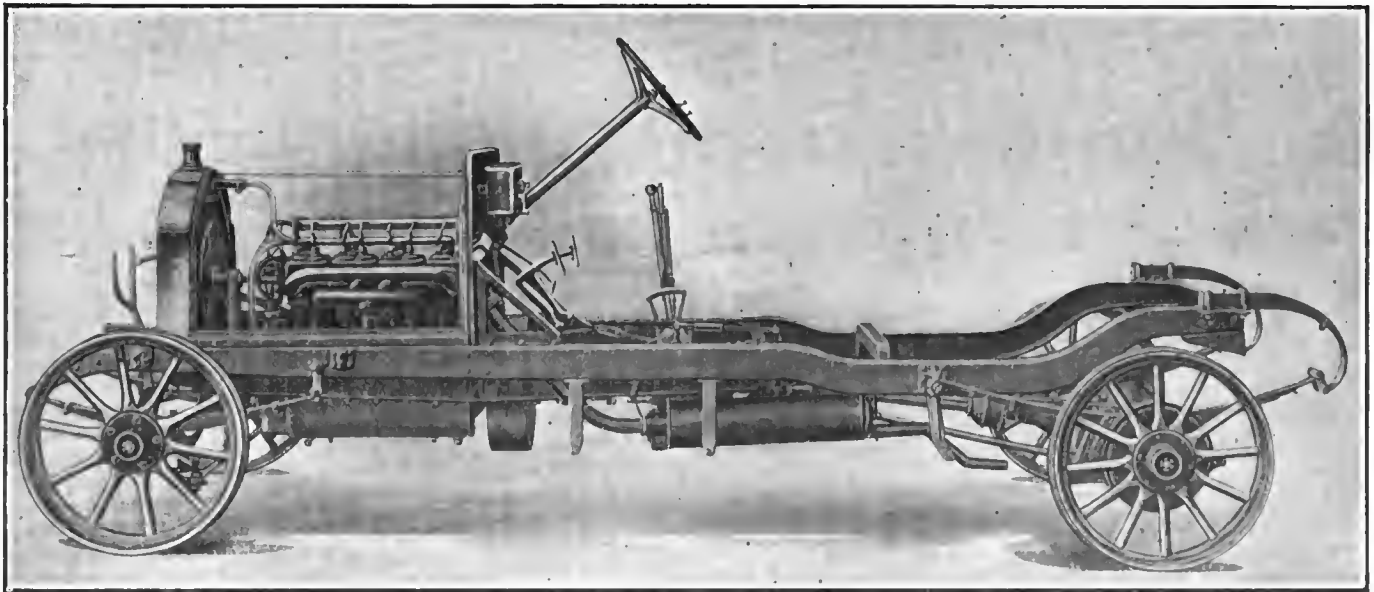

Fig. 1—Chassis used in connection with the Model F Lexington touring cars and coupé

## Elucidating the Lexington Line

**A**MONG the most recent announcements of cars placed upon the market for the season of 1912 is that of the Lexington Motor Car Company, of Connerville, Ind. This company has confined its efforts to two styles of chassis and has fitted these with six styles of body, embracing five-passenger touring car, demi-tonneau, coupé and roadster types.

The two chassis are equipped with motors of different types, one being the Model X Rutenber and the other the Model R A Rutenber. The Model X motor is used in the D F touring cars and the Model E roadster in connection with the smaller chassis of the two. It is rated by the makers at 40 horsepower and has four single cylinders having a bore of 4 1-8 inches and a stroke of 5 1-4 inches. The inlet and exhaust manifolds N and M, Fig. 3, and the valves are located on the same side of the motor and are operated from the same camshaft. The cam

action is made very accessible by the fact that the fulcrum about which the valve lifter lever swings is attached to a removable cover plate. When this plate is removed the lifter and follower are withdrawn with it so that a close inspection for wear can be made. The cams are designed to give a lift of 3-8 inch to both the exhaust and inlet valves. The valves are composed of two different kinds of steel, according to the latest practice in valve-making; the heads are of nickel steel and the stems are of carbon steel. The camshaft is a drop forging and is supported by three plain bearings; it is driven off the crankshaft by means of the half-time gearing, which is located in a casing situated at the front end of the motor.

The pistons are long and are equipped with five rings, four being above the wrist-pin and one at the same level as the center of the wrist-pin. There are three grooves in the piston below

the wrist-pin, which pick up the oil that is thrown from the crankcase and distribute it to the cylinder wall. The wrist-pin is hollow and is supported by a bushing which is cast integrally with the piston. The connecting rod is attached solidly to the wrist-pin, which oscillates with the motion of the connecting rod and hence uses the bushing as a bearing surface. At the wrist-pin ends the connecting rods are fastened with clamp bolts, which are held in place and locked with washers and lock nuts.

The crankcase of this motor is cast in two entirely separate parts. The upper part carries the supporting arms for the motor, of which there are four, and also supports the five bridges which carry the main bearings. The lower parts of the bridges are removable, while the upper halves are integrally connected to the upper part of the crankcase casting. In the four front main bearings there are two supporting

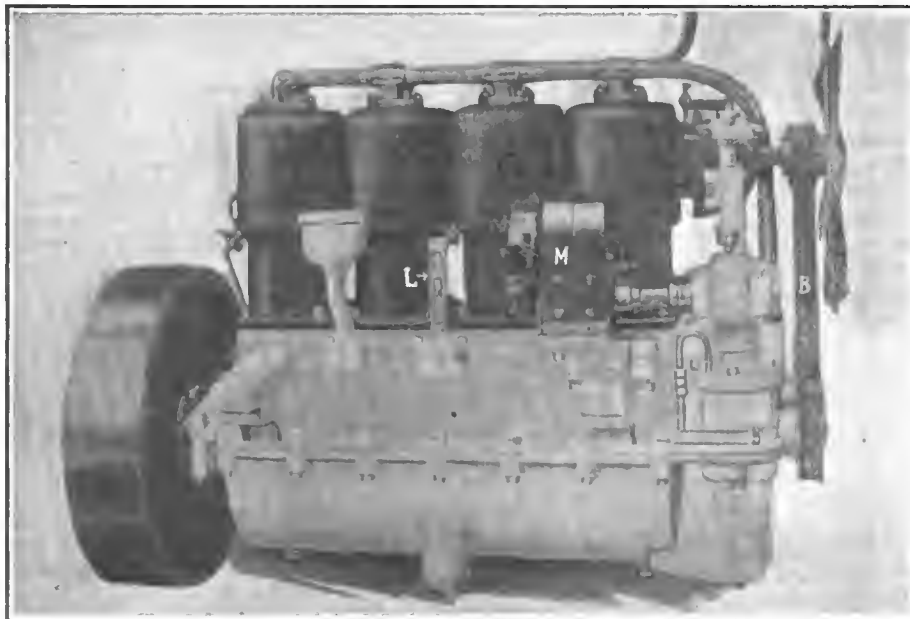

Fig. 2—Magneto side of Model R A Rutenber motor used in larger Lexington cars



bolts, while in the rear main bearing four bolts are provided to give ample protection against the vibration which may be caused by the flywheel. The lower part of the crankcase is not only free from the upper part, but is independent of all the bearings and gearing; hence it may be removed at pleasure without any fear of disturbing any of the moving parts of the motor. It is attached to the upper part of the crankcase by means of bolts, and when dropped, gives easy access to all the connecting rod and main bearings.

The manifolds are placed on the left side of the motor, one above the other. The lower of the two is the intake manifold. The carbureter is suspended from the center of the intake manifold, N, which is of Y-shape and flanged for the purpose of holding the carbureter, which is of the Schebler type. The flange which supports the carbureter is of large size in order to safeguard against a leak at this point.

The motor is cooled by water, the jacket space surrounding the valve chambers as well as the combustion space. The water circulation is maintained by a centrifugal type of pump, which is driven by gearing and by the same shaft that operates the magneto. The radiator is kept cool by a five-bladed fan which is driven off the end of the shaft by means of a belt and pulley. The bracket which holds the fan is adjustable.

The lubrication is a combination of the force-feed and splash systems. The oil reservoir is located in the lower part of the base casting, being contained beneath a horizontal partition which subdivides the base into an upper and lower compartment. The lower part furnishes the reservoir, while the upper part is a sort of tray carrying the splash troughs which are a factor in the lubrication system of the motor. The capacity of the reservoir is in the neighborhood of two gallons. A gear pump located at the front end of the motor in the bottom of the base chamber draws the oil from the crankcase through a wire-gauze screen and forces it through leads into the main bearings of the crankshaft. After the oil has passed through the main bearings it will overflow into the splash troughs on either side, and create a pool of oil in each of these troughs. At each revolution the ends of the connecting rods are dipped into these

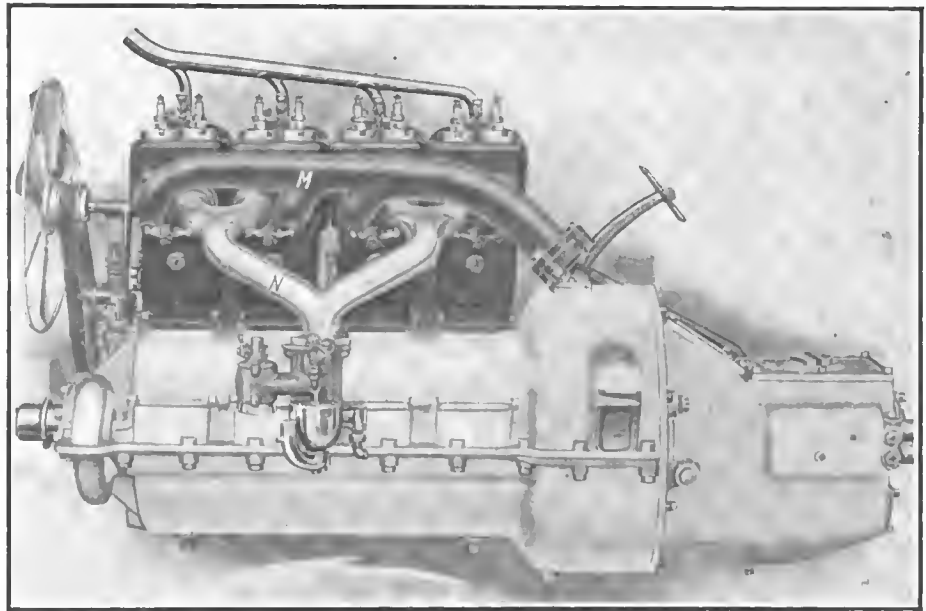

Fig. 3—Manifold side of the Model X Rutember motor, used in the smaller Lexington cars

splash pools, creating a mist of oil which fills the crankcase and lubricates all the other bearings. The constant level is maintained in the splash troughs because the oil is supplied much more rapidly than it is used, and there is an overflow port provided so that when the oil rises to a certain height it will return to the reservoir. A float level gauge is fitted on the base.

The clutch is of the leather-faced cone type. It is made of aluminum and is recessed below the leather to accommodate 12 springs (M, Fig. 6) so inserted as to provide for easy engagement. The pedal which controls the clutch is adjustable for length to suit the requirements of the driver. The crankcase casting is carried back far enough to enclose the clutch; the gearset housing is then bolted on the end of the clutch casing, making a complete covering for both these parts. The combined housing for these two parts is illustrated in Fig. 6. An inspection cover C, held by the thumb nuts N, is fitted so that easy access may be had to the working parts. A plug L is provided for the insertion of grease into the gearset housing and the casing itself may be taken off by the removal of the bolts B which hold it in place. The gearset housing may be drained by means of a small drain plug located in the bottom of the housing at the front end. The male member of the clutch is

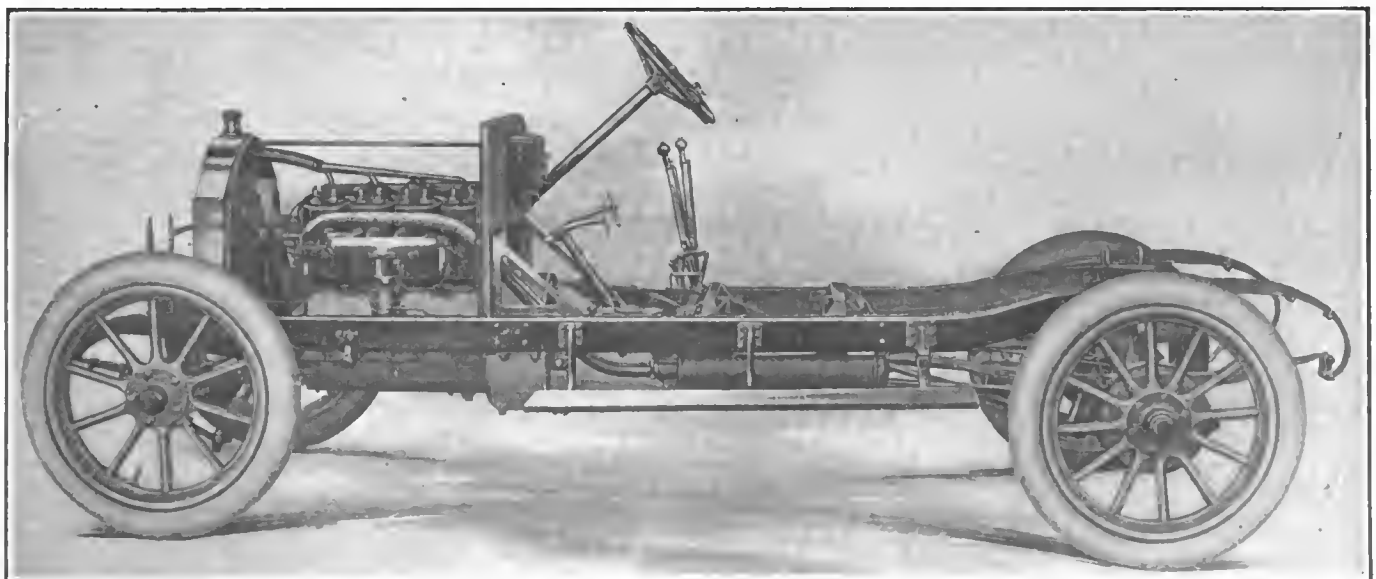

Fig. 4—Illustrating the chassis used in connection with Models D F and E Lexington touring car and roadster

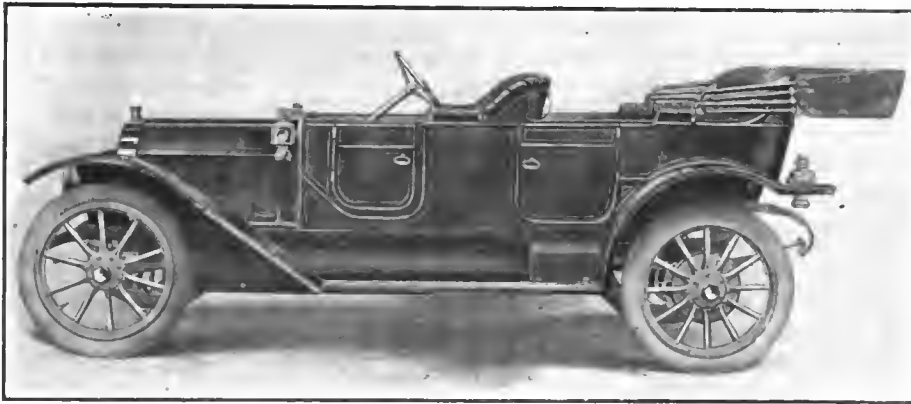

Fig. 5—Model F Lexington demi-tonneau, equipped with Model R. A. motor

held to the drive shaft by a fitting which passes over the squared end of the shaft and is bolted to the clutch by means of the bolts P. The drive shaft D, passes through a stuffing-box at the front end of the gearset housing and engages with the change-speed shaft E. By shifting the shaft E with the change-speed lever, three forward and one reverse speeds are obtained. The shafts are provided with ball bearings and there is a thrust bearing arranged to take the thrust from the clutch.

The drive is taken up beyond the gearset by the propeller shaft, which is fitted with a universal joint at either end, and thence passes through a stuffing box and roller bearing support into the differential. The differential is of the Timken type, a short shaft passing through two Timken roller bearings and terminating with a pinion which engages with the differential, this being also mounted on roller bearings. The rear half of the differential casing is removable by unscrewing the bolts which hold it in place. The bolts are kept tight by the use of split washers which are fitted both on the exterior and interior of the pressed steel housing. A plug for the purpose of inserting lubricating material and a drain are also provided. A flange to which the two triangular spring-mounted torque rods are fitted by means of bolts, is provided on the exterior of the differential housing.

The brakes are of the external and internal type, being mounted on a steel drum as shown in Fig. 8. The internal brakes are operated by the brake lever and form the means of braking the car in an emergency. The illustration shows the method of adjusting for wear and for drag. When the brake is applied the internal lever is drawn back and the two cams P, which are pivoted at P<sub>1</sub>, are pushed together, thus applying the brakes. The spring shown in the illustration is fitted for the purpose of drawing back the brakes into their regular position when the lever is released. When the ordinary or foot brake is applied the exterior contracting band is drawn over the drum by means of the bell crank lever and is released by the spring when the pedal is allowed to return to its ordinary position. The drum is held in place by through bolts which are fitted with cotter pins to keep them in position.

The front axle is of the Timken type and is a solid I-beam section, drop-forged. The steering spindles are of alloy steel, heat treated. The rear axle is also a Timken product, being of the floating type revolving on roller bearings. It is enclosed in a housing of pressed steel and is of heat-treated alloy steel. The driving axles are squared at both the differential and wheel ends so that they may be easily withdrawn by removing the hub cap. When this hub cap is removed the end of the axle is exposed, and by inserting a special tool the drive shaft may be removed without disturbing any part of the wheel. The drive is transmitted to the wheels from the axle by means of steel fittings which pass over the end of the squared drive shafts and extend to the wheel flanges. The six bolts which connect the axles to the wheel pass through the brake drums, thus forming a very rigid and efficient connection. Just inside the roller bearings a bushing prevents the passage of oil into the brake drums.

The wheels are intended for 34 x 4-inch tires all around on the D F and E models. They are fitted with universal Q. D. rims and work on Timken bearings, both front and rear.

The chassis frame is of channel section throughout. It runs back on a straight line until it reaches a point about 2 feet forward of the rear axle, where there is a rise which terminates over the rear supports.

The bodies supplied with this chassis are of two types—the Model D F, a five-passenger touring car, and the Model E roadster. They are both supported on semi-elliptic springs at the front with a 2-inch offset center and at the rear with

three-quarter elliptic springs with a 2-inch offset. All the springs are steel bushed, reamed to size and fitted with grease cups. They are held in position with clips and tie plates. Both types of body are equipped with the worm and gear type steering gear. The steering column is fitted with an 18-inch hand wheel with aluminum center. The spark and throttle control quadrants and levers are located on the top of the steering wheel.

The equipment consists of a Bosch magneto, five lamps, pump, jack, tools, robe-rail, foot rest and generator. The color of the car and the upholstery are optional. The entire vehicle fully equipped without passengers weighs about 2,700 pounds.

#### Mechanical Details of Model F Chassis

The Model R A motor, which features the larger chassis, which is used in connection with the Model F bodies and the Lexington coupé, is also a Rutenber product. The bore is 4 1-2 inches and the stroke 5 inches. There are four separately-cast cylinders, as in the Model X motor. The inlet and exhaust valves are located on the same side of the motor and are operated off the same camshaft. The valve springs are on the exterior of the motor and are accessible to inspection and adjustment without the removal of any other parts. There are two nuts on the lower end of the exposed part of the stems by means of which the adjustment of the valves can be easily effected.

The cam action is made accessible by means of removable cover plates which are held in place by bolts. The camshaft is supported at three points in its length, the central point of suspension being in the same transverse plane as the central main bearing of the crankshaft. There are four cams on either side of this central support, which take care of the valve action of all the cylinders. The lower ends of the valve stems are equipped with followers, which rest upon the lifter fingers. The

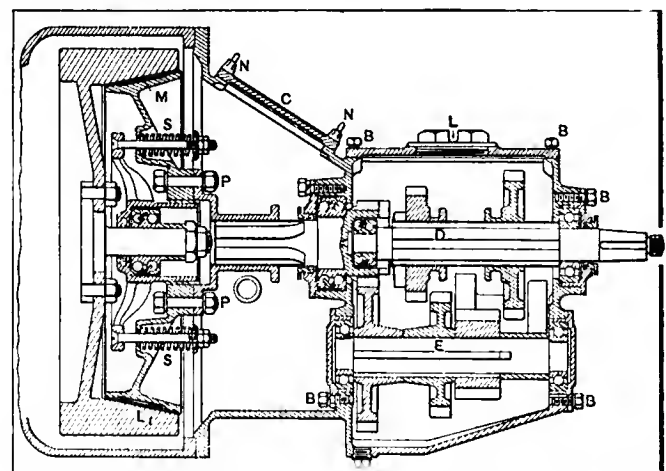

Fig. 6—Vertical section through the clutch and gearset

action of the cam is transmitted to this finger by means of a roller follower, which gives a lift of 3-8 inch to the valves. The valve-heads are of nickel and the stems of carbon steel.

The pistons are equipped with five rings in the same manner as the Model X motor. The connecting rods are clamped to the wrist-pins rigidly, and the bearing surface for the wrist-pin is provided by a bushing which is an integral part of the piston.

Carburetion is effected by means of a Schebler carbureter which is supported in the same manner as on the Model X motor.

The motor is lubricated by the splash system as well as by the oil which is forced to the main bearing by means of a gear-driven pump located in the front lower end of the base casting. This pump is surrounded by a screen, through which all the oil which is sucked up by the pump must pass. After being led to the main bearings the oil overflows into splash troughs and then passes back into the reservoir, which is located in the lower half of the base chamber. The crank bearings, camshaft bearings and all other moving parts receive their lubrication from the oil which is thrown up by the splash of the connecting rod into the pools of oil contained in the splash troughs. There are two independent methods of draining the crankcase. The upper part of the base chamber which contains the splash troughs is drained by one set of plugs, while the lower half or oil reservoir may be drained by another. The reservoir is fitted with a level gauge L, Fig. 2.

Ignition is affected by two systems which are entirely independent of each other, having separate spark plugs. There are hence two spark plugs in each cylinder. One system is operated by dry batteries and coil, while the other is taken care of by a Bosch magneto M. The coil for the dry batteries is located on the dash and is of the four-unit type. The magneto is located on the opposite side of the motor from the intake and exhaust manifolds and is driven off the same shaft as the centrifugal water pump.

The motor is cooled in the same manner as the model X, the fan driven by the belt B being made larger.

The flywheel is not encased in this motor, the crankcasing terminating at the end of the crankshaft.

The clutch is of the leather-faced cone type, the metallic parts being identical with those used in connection with the smaller chassis. The clutch is controlled by adjustable pedal.

The gearset is of the type manufactured by the T. W. Warner Manufacturing Company. It is of the selective sliding gear type mounted on annular bearings supported by a sub-frame.

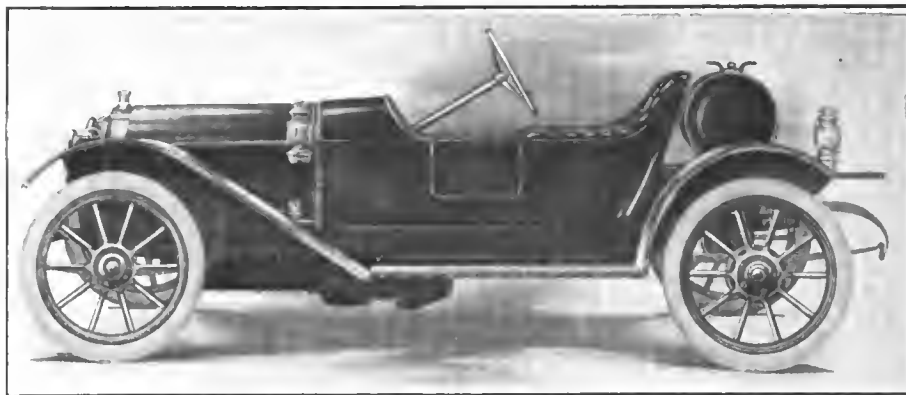

Fig. 7—Lexington Model E roadster, with tank mounted on the afterdeck

The propeller shaft is fitted with two universal joints in the same manner as that used with the Model X motor. Between the clutch and gearset there are also double universal joints so that all strains will be released. The torsional strains are taken care of by triangular torque members of tubular form. The front ends of the torque members are cushioned on heavy springs which are mounted on the cross member of the main frame, the rear ends being bolted to the differential housing.

The front and rear axles are both of Timken manufacture of the same general style as those described for the other type of chassis, but made heavier to sustain the added weight of the heavier motor and body. The other frame members are similar to those of the other chassis except that they are of double dropped construction and somewhat heavier.

The brakes are of the internal and external type, with drums which are 14 inches in diameter and 2 1-2 inches in width. They are bolted to the rear wheels and are adjustable for wear and play.

The bodies fitted with this chassis are of four varieties: two five-passenger touring, one with fore-doors and the other without; a demi-tonneau, and a coupé. They are all mounted in a similar manner with semi-elliptic springs with a 2-inch offset in front and in the rear with three-quarter elliptic springs having the same offset. All the spring eyes are fitted with hardened steel bushings and the bolts are hardened and ground. They are fitted with integral grease cups.

The steering gear is of the worm and gear type of the same general description as that fitted on the smaller cars.

The equipment consists of a Bosch magneto, horn, five lamps, pump, jack, tools, generator, 36 x 4 tires, robe rail, foot rest, and cocoa mat in tonneau. The color of the body is optional, as is also the upholstery.

In placing these two styles of chassis with the six types of body upon the market the Lexington company has not made any radical changes from the models presented in the season of 1911. There are a number of small refinements which have been incorporated in the new models, however, to bring them up to date. Either of the three touring cars is designed to fill the requirements of an every-day car for all-around use. The five-passenger touring cars furnished with the larger chassis are identical except that one is equipped with fore-doors while the other is not. The five-passenger touring car body fitted to the smaller chassis is equipped with fore-doors and is of the same general type as the larger cars except that it is smaller. The coupé, which is fitted on the larger chassis, is furnished with an extra folding seat placed to the left of the steering column so that an additional passenger may be accommodated. The demi-tonneau car is designed for five passengers and is supplied with the larger chassis. The principal differences between this car and the larger touring cars are the closer lines and the longer steering column, which is raked at a sharper angle. The remaining car, the roadster, is mounted on the smaller chassis and has been designed with the object of providing a racy appearance.

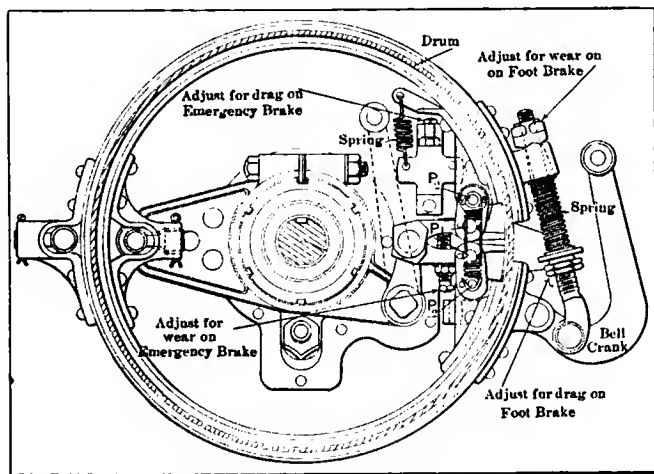

Fig. 8—Longitudinal section through the brake, showing methods of adjustment

AMONG the things that contribute to the pleasure of automobiling and that save wear and tear on the nervous system at a ratio that it is impossible to estimate, are the little things that keep within easy reach the tools and parts needed to make repairs, insure accessibility of the side curtains, etc. Extra cushions or pillows in the car, that can be used as foot rests or that can be utilized to bolster up the back, are another useful addition. More of these simple and useful things are to be found on the new models than ever before; the number is bound to be augmented, too, because the number of car users is increasing, and that means that more people will be interested in the weeding out of the makeshift system that so frequently obtains.

It is usually the novice who institutes reforms; the man who really knows succumbs to the prevailing conditions, whereas the new-comer protests vigorously at the sight that is presented when the occupants of the car are made to file out and stand on the road while the box under the rear seat is ransacked for inner tubes, side curtains, the jack or pump, or any old thing that does not happen to be provided with a home in some other part of the car or in the tool box on the running-board. Then, too, it may be raining at the time and this will add to the varieties of the sensations that are experienced.

Fortunately the refining process is making headway rapidly, and car-users with good common sense are beginning to have the old adage of "a place for everything and everything in its place" apply to the interior of a car as well as to any other piece of property that they may possess. The competition in making sales at the present day is developing this faculty of making things look shipshape; features that are commendable are being generally adopted and those that are the reverse are being eliminated.

Among the articles that are indispensable are inner tubes, and when it is considered that these are so delicate that they should be protected from contact with most other articles carried, and that they may be needed at any moment, does it not seem reasonable that a safe, dry and separate pocket should be provided, one that will be easily accessible without disturbing the occupants

## Flaws in Motor Castings

FLAWS in castings are common, and very often impossible to detect. The metal near the top of the mould when making a casting will often be of a quality which is not nearly so desirable as that at the lower part. For this reason cylinders are cast upside down so that the better material will be found in the combustion chamber and heads. In best practice cylinders are cast in moulds which are too long for the particular piece of work in hand; the upper metal is then removed so that the entire cylinder is composed of the best material possible. This practice is common in the manufacture of all automobile engine cylinders where high-grade workmanship is made an objective point. Drop forgings are as a rule more reliable than castings, not being so subject to flaws and blow-holes, and in smaller parts they are used to a large degree. Defects in machined or cast parts cannot be charged to a lack of vigilance on the part of the proprietor of the car, and are mentioned merely to show in what manner breakages may occur which will fall outside of the home care of the car and inside the realm of the maker's guarantee.

CRYSTALLIZED alumina in aluminum bronzes is not only weakening but, being identical with emery, if it is found in a bearing it is as fatal as emery ingrained in the bronze would be. The presence of alumina is easily told, however. It is only necessary to polish a piece of the bronze. If the polished surface is entirely unbroken and smooth, alumina is not present. Should it be there, the buffer wheel produces characteristic streaks and lines.—Durville in *La Technique Moderne* on High Resistance Bronzes.

## Utilizing the Space

of the tonneau? Figs. 1 and 2 illustrate two views of the front seat that show in section on the side elevation such a pocket as described above. The plan view shows the two seatings; it is practically an offset seat, the occupant beside the driver being provided with a very deep seat cushion that allows him to sit well back in a comfortable position. Whereas the cushion on the driving side is less in depth, and the back of the seat is apparently provided with thicker upholstery, in reality it covers a pocket, as illustrated on Fig. 1, that provides room for two inner tubes suspended from a wood bar. This bar is removable and is passed through the inner fold of the tube, to remove which it is only necessary to take out the driving cushion and raise the door as illustrated by the dotted line indicating the door when raised. This door, as indicated on Fig. 2, is made the width of the folds in the trimming, and the hinge in the trimming at the top is naturally provided at the place where the points meet and the buttons are placed. The wood door at the

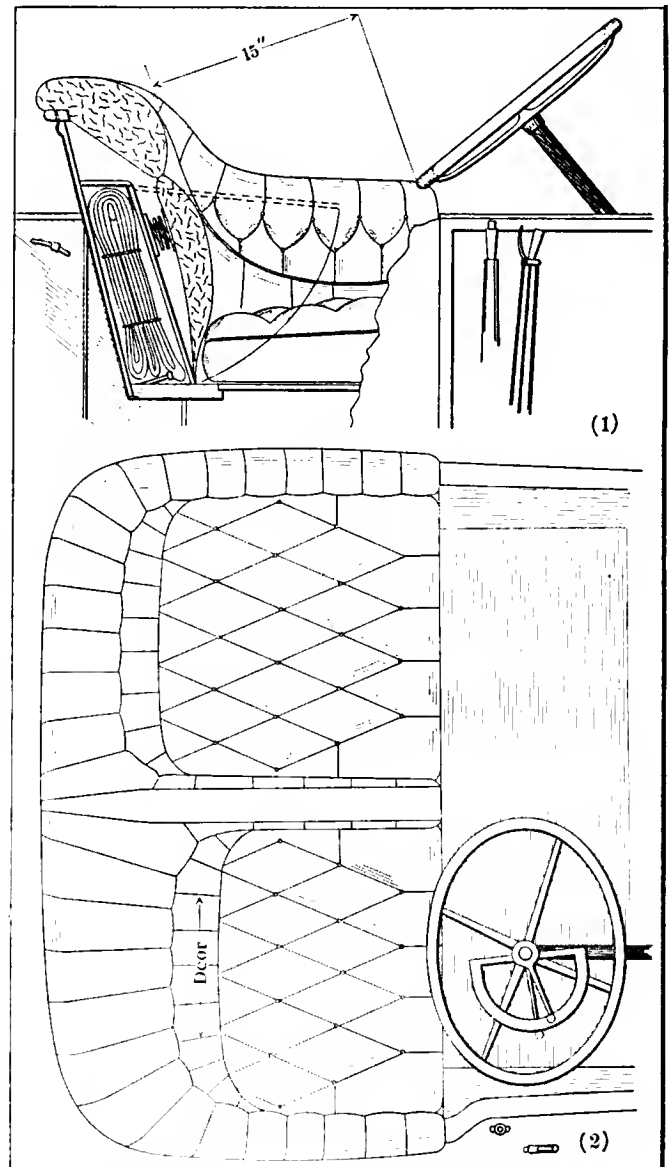

Fig. 1—Vertical section through front seat showing tire space  
Fig. 2—Plan of front seats indicating utilization of space

# in Car Body Design

back of the trimming is provided with a hinge at the top, and when down its weight and the cushion pressed against it, keep it in its position. As shown, the tubes are in a box formed by the back of the seat, the bottom of the seat frame, the sides that form a rest for the door, and the top piece to which the door is hinged.

Fig. 3 is an improvement that is finding much favor among the users of cars in England; it is simply a leather cushion or pillow, made without springs and very flexible. It is kept in position on the rear seat by means of a strap as shown, and can be removed and placed at the rear of the front seat or it can be used for a foot cushion if desired. If the seat is too narrow for three persons—and most cars are—the third occupant will sit forward and by leaning back on the pillow will have a comfortable seat. The maximum seating capacity will thus have been obtained without crowding. If the occupants of the seat are strangers, the unpleasantness of wedging in shoulder to shoulder

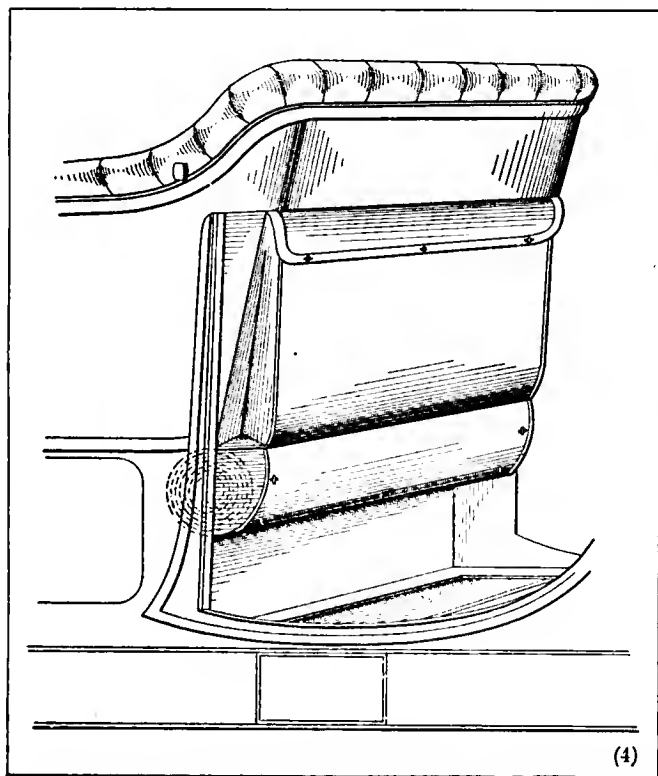
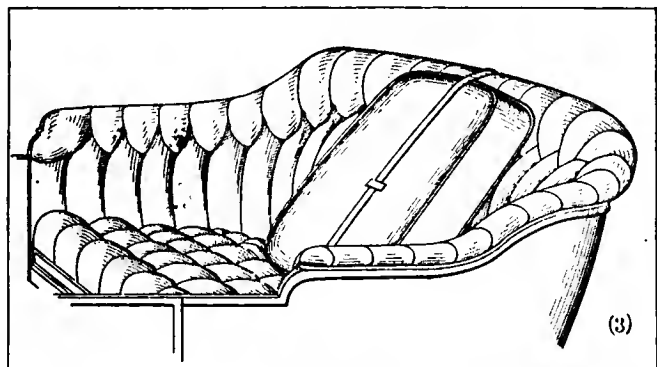

Fig. 3—Transportable leather cushion strapped to body of car  
Fig. 4—How tools can be stored under floor to advantage

is avoided. If the seat is occupied by two persons only, the pillow serves as an arm rest and helps each occupant to retain his position, giving a pleasing individual effect to the widest seat in the car.

Fig. 4 is an illustration showing the storm curtains stowed away in a pocket underneath the front seat at the rear. This receptacle is cylindrical-shaped and is formed of metal. The side toward the rear of the body is open to allow of removing and putting away the curtains, and this opening is covered with a leather flap that is buttoned along the bottom edge and on the sides. This idea of providing a place for the curtains is already incorporated in the new Thomas model, and Fig. 4 shows an adaptation of it, but made to suit the average car with the gasoline tank under the seat. The space from the back of the gasoline tank to the back panel of the seat is usually too small to allow of placing a cylindrical roll large enough to hold the curtains of the average top without showing conspicuously in the tonneau, and to overcome this a leather pocket of generous proportions is provided that will naturally project out from the seat back not less than 5 inches. The cylindrical metal box is fastened to the under side of the seat frame and the flap that covers the opening is made a continuation of the leather pocket, thus balancing up the interior finish of the tonneau and providing room for a receptacle that will contain all the top curtains. These will be carried rolled up loosely and in addition will always be accessible when needed, without disturbing any of the passengers. The roll of curtains is shown in the illustration in dotted lines and the flap is buttoned fast. The pocket shown need not interfere with a robe rail; that can be fastened above it.

At the bottom of Fig. 4 is shown a door in the floor that covers a box the depth of the frame as indicated by lines on the side. This box is intended to be used to carry the pump, the jack and the heavier articles that are frequently needed, and it suggests the great number of carrying spaces around the car that are not utilized—places that are easily accessible and that can be made to do service in storing away tools and articles needed for touring, and which could be made to supersede the boxes that are carried so conspicuously on the running-board.

## Oil-Burning Motor

DIESEL motors, while in principle too heavy for portable or automobile uses, are gaining new markets as power sources for factories and ships. They are now made not only in the four-cycle but also in the two-cycle type, and their economy no longer depends upon the price of crude oil in the locality where they are set up, as an improvement of the fuel mixer has adapted them to operate with oil of coal tar.

The gas and electric light company of Calais, France, which normally operates with the exhaust waste gases from a steel plant, has installed a four-cycle Diesel motor of 540 horsepower for reserve and emergency purposes, and this operates with oil of coal tar, making the cost per horsepower-hour 1.8 centimes at full power and 2.12 centimes at half power, as the oil costs only 8 francs per 100 kilograms and the average fuel consumption is about 225 grammes per horsepower-hour.

WHAT IS A HOLE IN THE AIR?—"Holes in the air," of which aviators complain, have been rationally explained. If an aeroplane is going against the wind with small speed, relatively to the earth, and then suddenly runs into a current which crosses its path or into a quiet section of the atmosphere, its speed is insufficient to uphold it and it drops and, if the motor power and propulsion are not strong enough to produce a rapid increase of momentum or if the aeroplane is too near the earth, the drop is likely to prove fatal. The explanation accounts for the accidents occurring when the aviator volplanes to earth with the motor power shut off and dives into unexpected currents near the earth's surface caused by hills, trees or buildings.—*Der Motorwagen*.



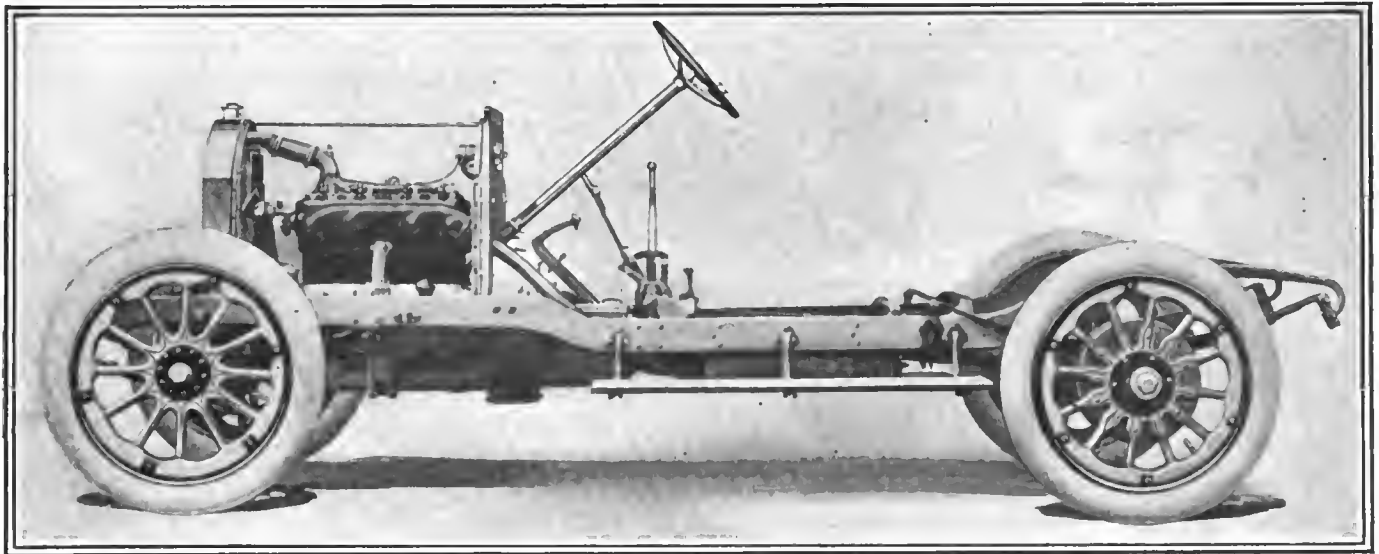
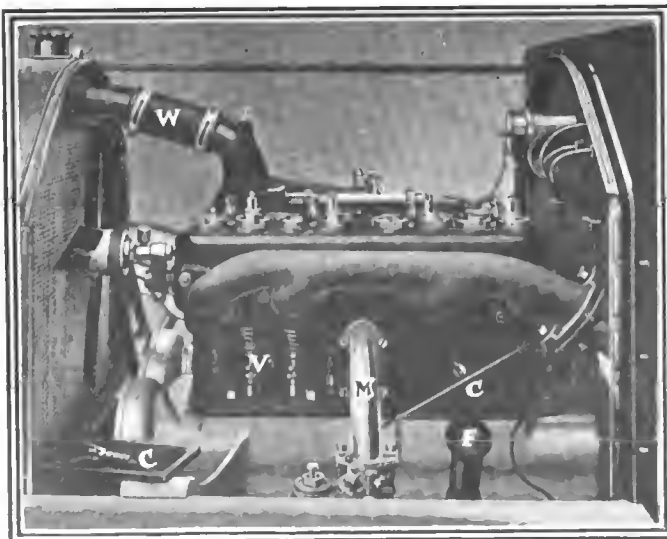
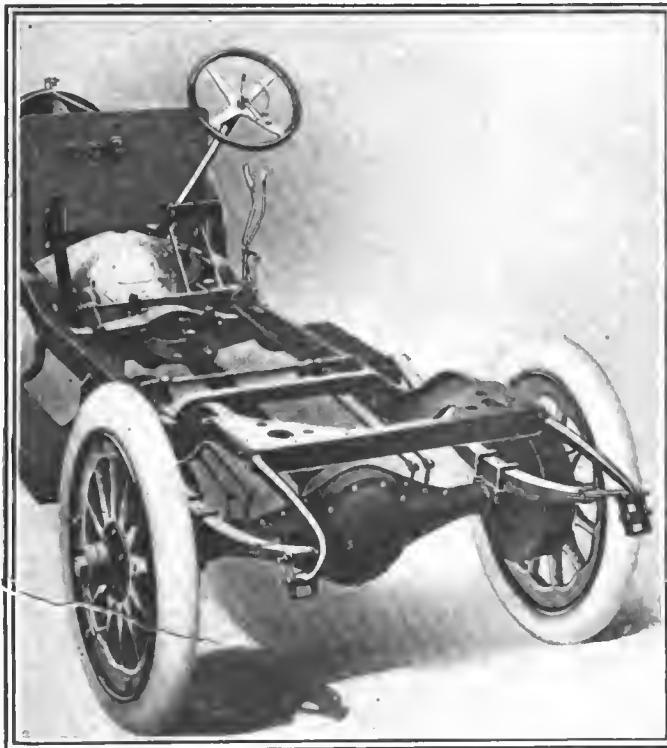

Fig. 1—View of new Pathfinder chassis

Fig. 2—Showing rear axle and suspension

Fig. 3—Illustrating left hand side of motor



## 1912 Pathfinder

**A**MONG recent announcements of 1912 models is that of the Motor Car Manufacturing Company, of Indianapolis, Ind., maker of Pathfinder automobiles. This company has placed on the market three body models—a five-passenger touring, a four-passenger phaeton built on toy-tonneau lines and the armored roadster. These are all mounted on the same standard chassis.

The motor with which this chassis is equipped is of the "bloc" type, having four cylinders with a bore of 4 1-8 and stroke of 5 1-4 inches. The valves are all on one side of the cylinders, with the valve springs and push rods V, Fig. 3, enclosed by the covers C to facilitate inspection and removal of parts. The intake and water outlet manifolds are cast integrally with the cylinders, and the opening which permits of inspection of these has been placed between the cover plates to insure easy access. The push rods are supplied with roller cam followers and give the valves a lift of 5-16 of an inch.

Cooling is accomplished by means of the thermo-siphon system. Two large pipes W; a fan F, Fig. 5, driven by the belt B, and a cellular radiator constitute the system. The motor is supported directly by the main frame at four points and the crankcase is extended rearward so as to entirely enclose the flywheel and act as a support for the gearset. A plate is provided in this housing so that the flywheel may be very easily reached for inspection.

The clutch is of the leather-faced cone type. It is 14 1-2 inches in diameter and has a face 2 5-8 inches wide. Six spring plungers beneath the leather provide an easy engagement. The clutch is held to its work by a 250-pound spring. The power is transmitted by a three-speed selective type of gearset of heat-treated chrome nickel. All shafts are mounted upon annular ball bearings.

The ignition is by means of the Eisemann or Bosch dual systems. For magneto adjustment an arrangement has been devised whereby the rear member of the Oldham coupling, joining the magneto M with its drive shaft, has been enlarged and contains 17 holes, the other member having 16, hence the adjustment may be varied by steps of 1 degree and 18 minutes.

There are two independent systems of oil circulation, each system having its own circulating pump, of the plunger type.

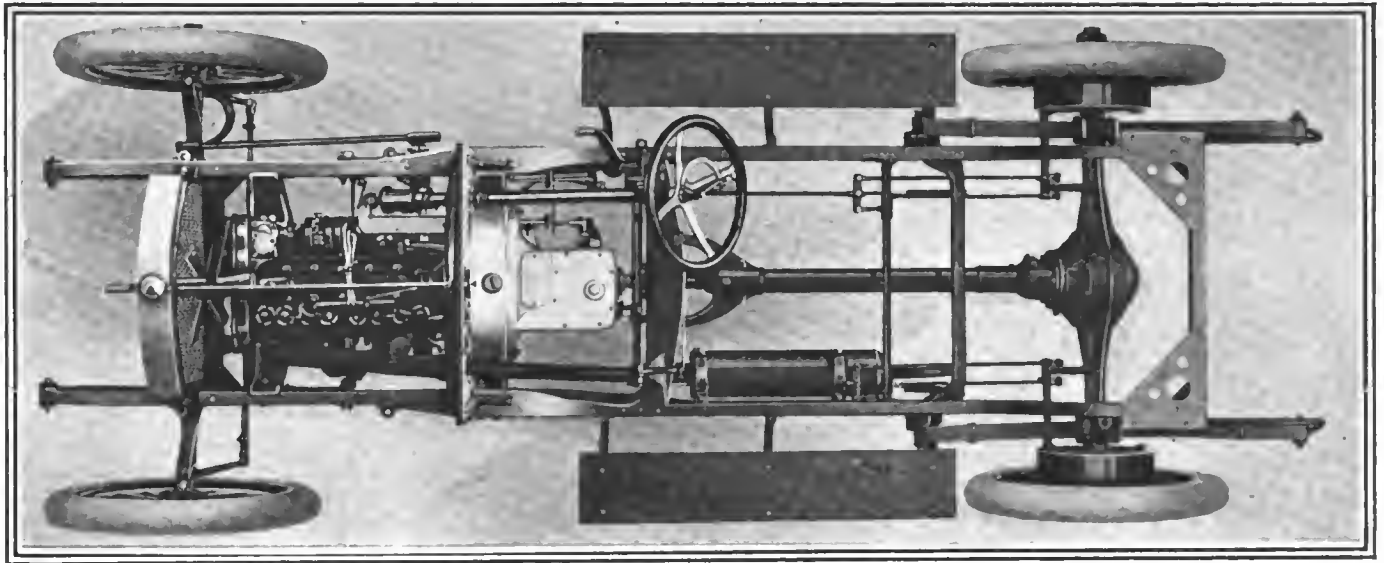

Fig. 4—Plan view of Pathfinder chassis  
 Fig. 5—Control mechanism of the new car  
 Fig. 6—Right-hand side of motor, showing magneto

## Makes Its Bow

These pumps are located on the valve side of the motor and are driven by the camshaft. Both pumps and their check valves are removable by withdrawing the plugs which are fitted beneath them. The oil is forced from the pumps to the sight feeds on the dash, all the piping except the leads to the sight feeds being incased in the crankcase casting to afford protection and insure a neat appearance. The oil reservoir is in the base and is filled by means of the filler tube F. There are two separate sight feeds located on the dash, one for each system. Both are of the bull's-eye type and are flush with the face of the dash. The oil flows from one sight feed to the rear main bearing and overflows into the rear splash trough and from the other sight feed to the timing gear case, overflowing into the foremost splash trough. In this way the oil supply will be uniform whether the car be ascending or descending a hill.

One universal joint, of the Spicer type, connects the gearset and propeller shaft. The drive shaft is covered by the torque tube. Under full passenger load a straight line drive is obtained, while with an empty car there is a three-degree angle between the shafts. The rear axle is of pressed steel with a vertical weld, its thickness being 3-16 of an inch.

The rear wheels are mounted upon two rows of ball bearings and are driven with six-jawed clutches. Brake drums are mounted on the rear wheels and are bolted to alternate spokes. Inside these drums are a pair of internal expanding brakes mounted side by side. They are 16 inches in diameter by 1 3-4 inches in width and are operated by means of whiffletree equalizers mounted on one of the frame cross members. Each brake can be adjusted from a point conveniently located under the floor boards at A, Fig. 5.

Both front and rear wheels have 1 5-8-inch spokes and carry Universal demountable rims, of which the equipment specifies one extra. The tire equipment is 34 x 4 inches all around, the tread being 56 inches, although a 60-inch tread will be supplied to Southern customers if so desired. The suspension both front and rear is by means of semi-elliptic springs. In front the length is 38 inches and in the rear 50 inches. The center of gravity of the car is kept low by means of the flat springs and a dropped frame. The shackle pins are hardened and lubricated by grease cups.

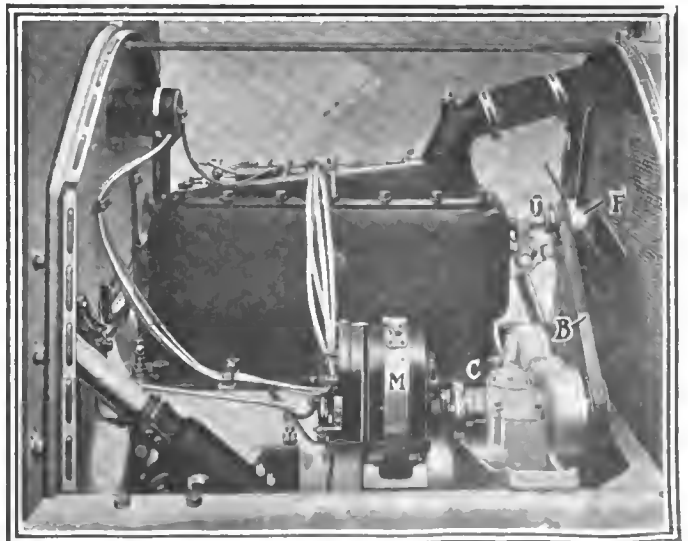
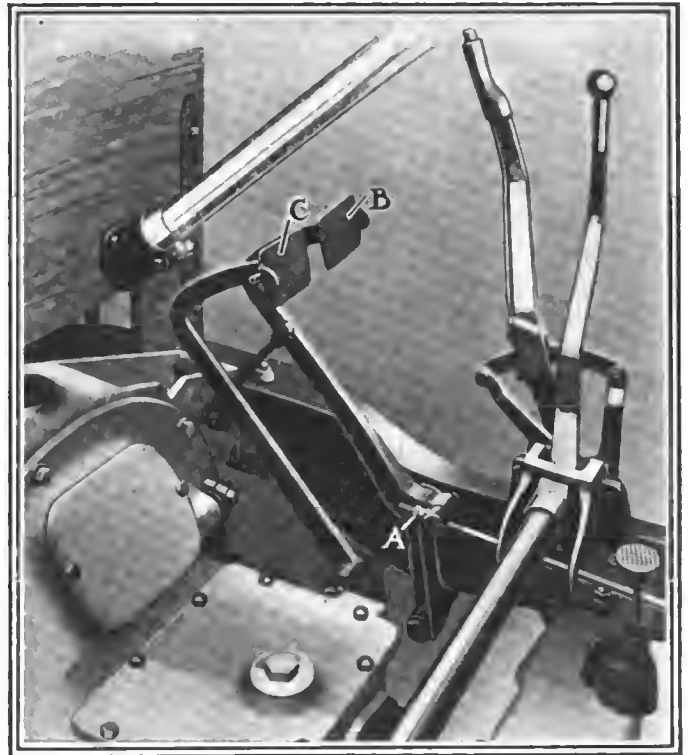

The change speed and emergency brakes are at the side and within both the body and the frame. Spark and throttle levers are placed as usual upon the 18-inch corrugated mahogany hand wheel. Clutch and brake pedals, C and B, are placed on the foot-board, with the accelerator between the two. The clutch and brake pedals have separate fulcrums. The centers are so arranged that the difference in arcs through which each pedal will travel is very slight. The object of this construction is to give straight-line pull upon the brake linkages and at the same time to obtain the proper reduction at the brake rocker arm.

In the steering gear a full worm wheel is used so that should there be wear the wheel may be rotated and a fresh surface engaged with the worm. As the worm is set upon a square shaft it can be so turned as to present four new wearing surfaces. The steering gear may be set at any angle without interfering with the adjustment.

The armored roadster body is of distinctive design. On this car the tank is carried in a portion of the body back of the seats. The rear is bevelled off in order to accommodate spare tires. Fore-doors, steering wheel and control levers on the right side and ventilated dash are features of the design. On the runabout access may be had to the seats from either side.

The frame is of channel section, being 4 1-2 inches in height throughout the major part of the side members. The thickness of the metal is 3-16 of an inch and the flanges vary from 2 to 5 inches in width, depending upon their location. At the front the frame is 30 inches wide, while at the dash it widens out until it is 34 inches. The frame is dropped 3 inches just back of the dash and 6 1-2 inches at the rear. There are four transverse members to the frame, one being just back of the gearset. This is a malleable iron casting and serves to stiffen the frame and help support the gearset, the torque rod support, the muffler cut-out and the emergency brake rod.

## New Electric Limousine

A FIVE-PASSENGER limousine driven by electricity is now offered for sale by the Waverley Company, of Indianapolis. The most modern of electric equipment was necessary to operate a body of these dimensions and yet maintain the requisite speed and mileage capacity. The wheelbase is 104 inches, body sill 129 inches and length over all 144 inches. The wheels are larger than the former electrics produced by this company, the tires being 34 x 4-inch rear and 34 x 3½-inch front.

The motor is of the Waverley multi-polar type with an overload capacity of 360 per cent., which transmits its power to the transverse shaft by means of a silent flexible gear. From the transverse shaft the power is transmitted to the floating rear axle by a shaft drive and herringbone gears. All running parts work in a constant oil bath. Battery and arc are completely

controlled by the Waverley No-Arc controller, which provides four speeds either in a forward or reverse direction. The motor cannot be started, however, on any other than the low speed, thus making for the safety and comfort of the driver and passengers.

Pains have been taken by the makers to have the upholstery as luxurious as possible and to give the car a tasteful design. The general effect is that of the French town chariot.

## What Causes Sweating?

SWEATING is caused when the gasoline is vaporized, due to its refrigerating effect. Every liquid, when it is changed from its liquid state to a gas form, absorbs heat from its surroundings and the temperature of the surroundings is lowered. The amount of this refrigerating effect depends upon the characteristics of the liquid employed. Gasoline, for illustration, does not refrigerate nearly as much as anhydrous ammonia. The mere fact that the carburetor exterior and perhaps the intake manifold frosts up is a sign that a considerable amount of gasoline is being vaporized, perhaps too much. It might be well to readjust the carburetor with a view to starving the mixture with the hope perhaps that there will be less frosting and that the mixture will prove to be more efficacious for its purpose. The fact that there is no frosting must not be taken as an absolute sign of good working conditions, because if the liquid goes into the combustion chamber before it vaporizes it will then "crack," forming a carbon deposit over the internal surfaces.

Loss of power is due to so many things that it will be impossible to put your finger upon the precise trouble without going to some pains, more or less systematically. It is to be hoped that the compression in your cylinders is good, that the carburetion is satisfactory, and that the ignition system is capable and well timed. With all these matters properly attended to, it remains for your air-cooled motor to work at a sufficiently low temperature to permit of a sufficient weight of mixture to enter the cylinders and perform useful work. If your trouble is due to overheating, loss of power may then be charged to one or more wrong conditions, as pistons that stick when they are heated, due to expansion, poor lubrication, due to the burning up of the lubricating oil, and insufficient mixture, due to the fact that the incoming mixture is rarefied by heat, and this condition may be accentuated sufficiently to result in a noticeable loss of power.

THREE YEARS AHEAD OF US.—"Of course," says *The Automobile Engineer* for September, speaking of American manufacture, "the adoption of the long strokes will act just as it has here (in Great Britain), by producing lubrication, vibration and noise troubles; so it is likely to be three years before the average American engine is as good as is the average European engine now."

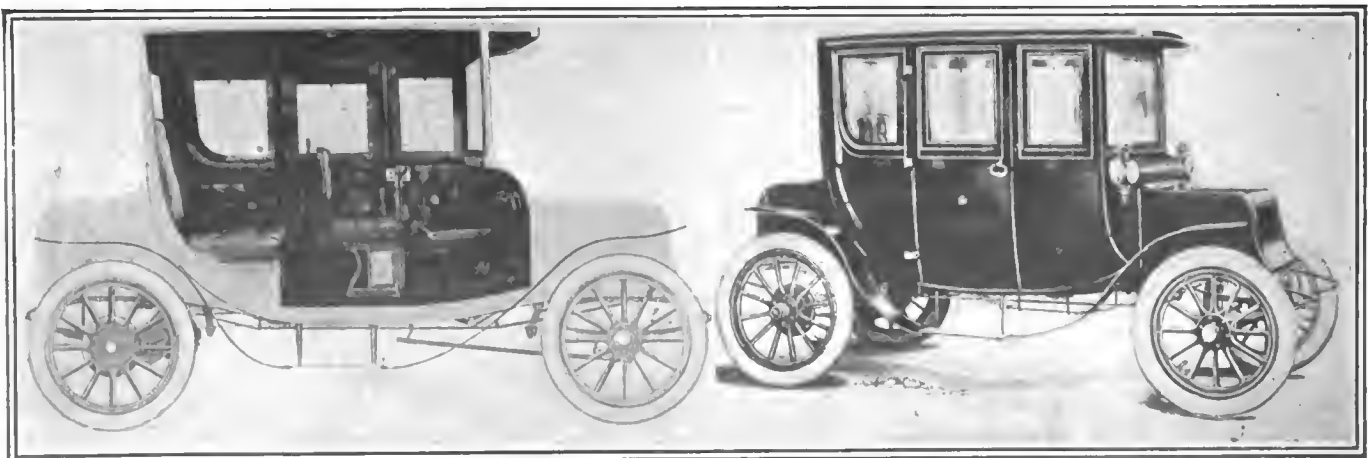

Fig. 1—Interior view of the new Waverley electric town car

Fig. 2—Illustrating the electric limousine produced by the Waverley Co.

# My 1912 Automobile

## Some Conceptions of What the Ideal Car Should Be

### Wants Multiple Disk Clutch

Editor THE AUTOMOBILE:

Permit me to add my idea to the many for an ideal 1912 motor car: The power plant of the car should be composed of a four-cylinder, four-cycle engine of 4 1-2-inch bore and 5 1-2-inch stroke, which would give the car about 32.4 horsepower, which is sufficient for touring purposes. The four-cylinder car is, I grant, inferior to the six-cylinder motor, but for horsepowers under forty I cannot find enough advantage in the six to warrant the extra cost. The engine should be of the L-head type, which will hold down the cost of construction, and the cylinders cast in pairs. The motor should be equipped with a Schebler or Stromberg carbureter and a four-cylinder tire pump fitted with clutch for engagement for pumping up tires.

Ignition should be from a Remy magneto light, which will furnish a complete electric lighting outfit for all lights on the car and also a dual ignition system.

A multiple-disk clutch of ample size and strength equipped with a ball bearing to act as a thrust bearing for same. Drive should be by shaft, enclosed and running on roller bearings with one universal joint, three-speed and reverse selective transmission running on roller bearings should be incorporated in rear-axle assembly. Rear axle should be of full floating type.

All wheels should be on roller bearings and the springs suspension should be of the best trade, being half elliptic in front and platform in rear; 36-inch x 4 1-2-inch tires all around, and standard quick-detachable rims used, not demountable. The wheelbase should be 120 inches. The front axle should be of vanadium steel in I beam.

A 25-gallon gasoline tank should occupy the rear of the chassis. The gasoline from this tank should be forced by automatic pressure to a small tank on the dash, and from thence flow by gravity to the carbureter.

The bearings in the motor should be of best babbitt and of large size the crankshaft main bearings not being less than 3 inches in length.

Lubrication should be from a self-contained plash in the crank case. Oil circulated by a gear pump with a glass sight feed showing amount of oil.

Frame should be best pressed steel, narrowed in front to permit short turns.

The brakes should consist of a service brake by pedal, operating two external contracting bands on drums on rear wheels,

and the emergency brake operated by lever should operate two internal expanding bands on the same drums. All brakes should have easy adjustments and equalizers. The control of the car should be from the right side in every sense of the word; no control levers in the center of the car.

This car should be equipped with a five-passenger touring car body with detachable foredoors, and ventilators in dash of a serviceable size. The equipment should consist of a good speedometer and clock, foot rest in tonneau and robe rail, good top and side curtains, a glass windshield, electric lights all around, tire carrying-irons at rear of car, a good bulb horn, and full set of tools, etc.

The above car should weigh 3,000 pounds and cost \$2,000, and should be put on the market by some old-established and reliable concern who have done business in building motor cars for years past. The parts for this car should be sold at a fair price direct from the factory to the user.

Lebanon, Pa.

C. L. W.

### Specifies Five-Inch Tires

Editor THE AUTOMOBILE:

The following are the specifications of my ideal car:

The engine should have six cylinders of the L type, cast in pairs, with removable plates over water jackets to allow cleaning, having a bore of 5 inches and stroke of 6 inches, with 2 3-4-inch valves with adjustable lifts, valves enclosed to exclude grit, giving it a full 60 horsepower.

Offset crankcase split in half with side opposite camshaft removable to allow access to and the removal of the crankshaft, connecting rods or pistons whenever necessary without having to take down engine.

The lubrication should be by positive force feed by gear-driven pump to all bearings and splash to connecting rods and pistons, oil contained in tank at side of engine with sight feed on dash.

Ignition should be by either Bosch or Eiseman magneto and storage battery, with two sets of spark plugs over valves.

The cooling system should consist of honeycomb radiator with gear-driven fan and water pump.

Selective type of transmission is my choice, with four speeds forward and reverse running on ball bearings with direct drive on third speed and geared 3 1-2 to 1 on direct drive.

The large diameter multiple-disk clutch should be mounted on ball bearings run-

ning in oil, with six tension springs equidistance apart, to allow taking up of wear.

A through shaft fitted with two universal joints should be packed in grease to differential with a torsion rod alongside, and from differential to rear wheels through live axle. Both differential and live axle running on Timken roller bearings.

The front axle should be of I-beam pressed steel, and a full floating type rear axle ought to be installed.

Twelve-spoke, 38-inch wheels of wood, mounted on Timken roller bearings should be fitted, these to be shod with 5-inch tires; all wheels with quick detachable demountable rims.

There should be four large brakes on two rear wheels, two internal for emergency, and two external for service.

The wheelbase should be 130 inches.

Semi-elliptical springs should be in front and three-quarter elliptical in rear, with Truffault-Hartford shock absorbers on each spring.

Steering should be by worm and sector gear, irreversible type, with 18-inch wheel.

The equipment should consist of fore-door torpedo type body seating five persons with comfort, with space enough in tonneau to accommodate two auxiliary seats whenever desired, top, windshield, speedometer with clock, two extra rims with tires, covers and tire irons, tire trunk, trunk rack and trunk, foot and robe rails, two headlights, two side lights and one tail lamp, all electric, getting current from storage battery charged by generator driven by engine, electric horn, engine-driven tire pump, jack, complete set of tools, and a positive self-starting outfit. A car such as this should cost \$4,000 or thereabouts.

HAZLEHURST.

Hazlehurst, Miss.

### Cheapness a Factor

Editor THE AUTOMOBILE:

I have followed with great interest the opinions of the various readers of THE AUTOMOBILE as to what the ideal 1912 car should be. I notice that in nearly all cases a high-priced car is specified, as is perhaps perfectly natural when it is considered that the very best materials and construction will enter into a car classed as ideal. It would seem to me, however, that a somewhat cheaper car should be described as the quality of cheapness is a very important factor to the average buyer of an automobile.

INTERESTED.

Readville, Mass.

# Letters Answered and Discussed

## Pipe Joint

EDITOR THE AUTOMOBILE:

[2,851]—Would you kindly tell me of a method of joining together two pipes of different sizes? I wish to make a solid joint that will not be apt to bend at the point of juncture and will hold its shape against considerable strain.

AMATEUR.

Fargo, N. D.

The best method of joining the pipes is by means of a brazed flange, as shown in Figs. 1 and 2. In the sectional view an idea of the way in which the flange is fitted is given. And if the fitting is made in this manner there will be no constriction of the free area. The distance C in the plan view should be equal to the diameter of the pipe plus twice its width in order to give a reliable fitting. The two inner circles in this drawing represent the thickness of the pipe and the outside circle shows the outside of the pipe flange.

## Pounds in Neutral

EDITOR THE AUTOMOBILE:

[2,852]—Kindly let me know through the columns of THE AUTOMOBILE the following: I have a 26-horsepower, four-cylinder, four-cycle motor, which, when in neutral, develops a distinct pound. However, when traveling at speed this noise disappears entirely. I have thoroughly cleaned the cylinders, and the carbureter is positively correct. What is the matter?

A SUBSCRIBER.

New York City.

You probably advance the spark too far when the engine is running free. This will produce a distinct pound. Loose parts would knock while running in gear.

## Cylinder Leaks

EDITOR THE AUTOMOBILE:

[2,853]—I am inclined to believe that there is a leak at some point in one of the cylinders of my four-cylinder 30-horsepower motor. Would you kindly tell me where the usual sources of leaks are found, and if there is a leak how it is detected? I would be greatly obliged for

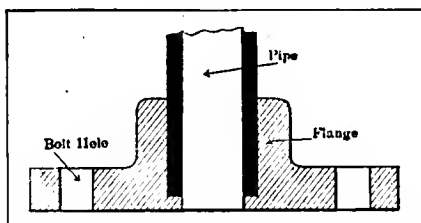

Fig. 1—Section through a pipe to which a brazed flange is fitted

The Editor invites subscribers to communicate their automobile troubles and personal experiences, stating them clearly on one side of the paper. If the nature of the case permits, send a sketch, even if it be rough, in order to assist to a clearer understanding. Each communication will receive attention in the order of its receipt, if the writer's signature and address accompany it as an evidence of good faith. If the writer objects to the publication of his name, he may add a nom de plume.



## My Best Repair

Temporary automobile repairs made by the driver or owner while on the road and permanent repairs made in the garage after the run is over, are interesting to all automobile owners.

Every driver at one time or another gets up against it. Something breaks or gets out of order on the road—a stop has to be made and some repair effected.

It may be a spring leaf has broken; a shackle bolt or strap may break; a steering tie rod is bent; the car skids into a curb and bends a steering arm or the starting crank; a throttle or magneto connection breaks owing to vibration; a radiator leak is started by a stone or some other means; a leak in the gasoline tank is discovered; there is a small hole in the gasoline feed line; a brake facing may burn out; a brake connection breaks; a front axle gets slightly sprung; a clutch starts slipping, or any one of a thousand things may happen.

Every automobile owner is interested in knowing how repairs have been made, how long it took to make them, how much they cost, and by whom they were made. All this information broadens the knowledge of the automobile owner and so helps the industry.

Thousands of car owners who are readers of THE AUTOMOBILE, have had experiences of this nature and have made a temporary roadside repair—a permanent cure at the garage. We want you to write in simple language in a letter what repair of this nature you have had to make, how you made it, how long it took you and how much it cost.

You can make with your lead pencil one or two rough sketches indicating the broken or damaged part and showing how the repair was made.

We are going to publish these repair letters from week to week in these columns. Every reader should send in one experience or repair and how accomplished.

Some have experiences with short circuits, adjusting carbureters, motor knocks, hard starting, noisy timing gears, etc. Information on how these were discovered or rectified are equally interesting.

The experience of each reader is interesting to every other reader. To you, some of your repairs or experiences may be commonplace, but to owners of automobiles with less experience they are most interesting.

Analyze your past experiences and send in one or two of them.

Give your name and address, legibly written. If you do not want your name to appear, make use of a nom de plume.

Editor THE AUTOMOBILE.

any information that you would give me regarding this trouble.

R. C. HOYT.

Camden, N. J.

First test for leaks about the spark plug or at any other points at which there is an opening into the cylinder. The test is made by putting light grease or heavy lubricating oil about the suspected points and watching for bubbles.

If the leak is in the piston it may be detected by allowing the motor to have a rich mixture and then opening the crankcase to see if there is any smoke within the confines of the casting. If there is smoke it may be taken as a sign that there is such a leak. The piston rings should be examined in a case of this nature.

Should the cylinder be cracked between the combustion chamber and the water

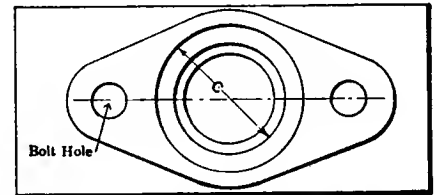

Fig. 2—Plan view of a brazed pipe flange showing the bolt holes

jacket the damage may often be very hard to detect owing to the fact that the crack will remain closed while the motor is cool, but as it heats up the crack will open. A cracked cylinder, though, will make itself apparent by the boiling cooling water.

Outside of the cylinders the valves should be noted to see if they are perfectly clean, as a leak will occur in the compression if there is a flake of carbon between the valve and its seat. Leaky exhaust manifolds are detected by a wheezing sound and leaky intake manifolds by a weak mixture which will cause popping back into the carbureter.

## Regarding Carbureters

EDITOR THE AUTOMOBILE:

[2,854]—Being a subscriber of THE AUTOMOBILE I would like to ask the following questions:

(1) When setting the adjustments on a carbureter, how many parts of air and how many parts of gas should be given?

(2) When setting the float level of a carbureter, when all the gasoline is out, how is it possible to tell when it is at the correct level?

A. J. K.

College Point, N. Y.



(1) In adjusting the carbureter the parts of air to gasoline are not determined, as they are allowed to vary at different speeds of the motor. The maximum explosive effect of gasoline is obtained when there are about eight parts of air to one of gasoline vapor. The carburetion will vary at different motor speeds on account of the greater amount of suction produced by the piston when traveling at the higher speeds and for this reason it is much easier to secure good carburetion at higher piston velocities.

When it is necessary to adjust the carbureter the matter should be gone about systematically and the steps taken well defined or else it will be an impossibility to secure the best results except by accident. The first step is to set the air valve in the mid-position, open the throttle about half-way, retard the timer and start the motor with the gears in neutral or the clutch disengaged. The throttle valve is then opened and closed quickly, with the timer set in different positions and the results noted. If there are back-fires, either open the fuel valve or close the air valve, according to judgment; if in doubt, try both and note

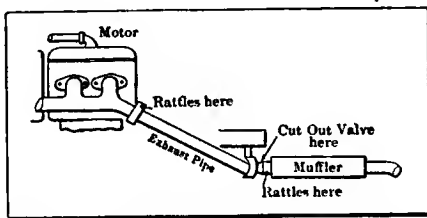

Fig. 3—Illustrating points of leakage in loose exhaust pipe

which gives the better results. If instead of back-fires the motor smokes, close the fuel valve slightly or open the air valve. When the motor works satisfactorily on different positions of the timer the car should be taken out on the road and put into high speed and the speed acceleration noted with the carbureter setting in the position which seemed best in the above-mentioned adjustments. Change the fuel valve setting without touching the air regulation until the motor picks up best along the road or up a hill, then note the effect of a slight change in the air valve in either direction. Vary these two (fuel and air valves) alternately until the most satisfactory results are obtained.

(2) The different makes of carbureters vary to a great extent in the manner of making the float adjustments. The height at which the float will be carried will vary with the density of the gasoline so that without the fluid in the chamber it would not be very well possible to ascertain the correct height with any degree of accuracy. The gasoline level should be about 3/32 inch below the level of the nozzle. It would be advisable in making the adjustment to obtain directions from the maker regarding the type you employ.

### Exhaust Pipe Rattles

Editor THE AUTOMOBILE:

[2,855]—The exhaust pipe on my car has become loose so that it rattles. I think it is probably due to having attached a cut-out valve in the position shown in the accompanying sketch (Fig. 3). It is loose both at the entrance to the exhaust manifold and at the muffler. Is there any way in which it may be tightened?

Ellenville, N. Y. A. D. P.

This is a job which should be turned over to a pipe fitter if satisfactory results are to be obtained. It might be possible to remedy the rattle temporarily by lagging the connections, with asbestos wrapped firmly about the points indicated, fastening this by means of metal strips which have been bent so that a small bolt can be passed through the ends and drawn tight. If necessary, the exhaust pipe should be rethreaded.

### Needs More Air

Editor THE AUTOMOBILE:

[2,856]—My motor, which ran very well up to a short time ago, has acquired some faults. The trouble seems to be in the carbureter, as the motor will smoke at all speeds. I do not like to change any adjustments without knowing what I am about. I wish you would direct me.

CARBURETER.

Saginaw, Mich.

You will find elsewhere on this page complete directions for making the adjustments on the carbureter. Before starting to adjust, note if it is clogged in the air passage, as shown in Fig. 4.

### Carbonic Gas in Tires

Editor THE AUTOMOBILE:

[2,857]—Some time ago there was an article in THE AUTOMOBILE relating to the effect of carbonic gas on the rubber in tires. My recollection is that it was stated that the gas had no deleterious effects, but that it leaked through the pores of the rubber much quicker than air will. I would thank you very much if you would tell me whether I am right or not concerning the properties of this gas.

J. S. A.

South Orange, N. J.

The properties of this gas in relation to rubber are as you state.

### Loose Steering Wheel

Editor THE AUTOMOBILE:

[2,858]—I would like advice on how to tighten my steering wheel. As far as wear is concerned, everything seems to be all right, but as yet I have been unable to find the correct place to make the adjustment. My car has a worm and sector type of steering gear.

J. H. B.

Swedesboro, N. J.

Loosen the nut in the eccentric bushing at the sector. Turn the bushing and tighten the nut. If the play is in the ball thrust bearing, the adjustment is made by tightening the nut provided for the purpose. If the balls are worn they should be immediately replaced.

### Washing Radiators

Editor THE AUTOMOBILE:

[2,859]—In your issue of Sept. 14, under the title of "The Upkeep of the Car" you advise washing the radiator of the car with a soda solution. Can you tell me what would be the correct solution to use?

G. F. W.

York, Pa.

The solution need not be carefully measured, a generous handful to a pail of boiling water being sufficient. Clean water should be run through the radiator after having washed it with the soda.

### Don't Use It

Editor THE AUTOMOBILE:

[2,860]—Would you kindly tell me what they put into the gasoline to increase the power of a motor when in a hill climb or race?

(2) What is a live rear axle?

READER.

Pittston, Pa.

It is not a very advisable proceeding to put anything into the gasoline. Picric acid has been used to some extent.

(2) A live rear axle is one which turns with the wheels of the car, the power being delivered through them.

### Oil in Gasoline

Editor THE AUTOMOBILE:

[2,861]—In regard to the practice of putting oil in the gasoline supply for the purpose of lubricating the cylinders, do you consider this advisable? If not, kindly inform me of the disadvantages incurred.

S. LINDON.

New York City.

This matter has been well threshed out in the columns of this paper in the issues of March 23, page 783; April 13, page 905; April 27, page 1014; May 11, page 1092; June 1, page 1223; June 22, page 1404, and July 20, page 108.

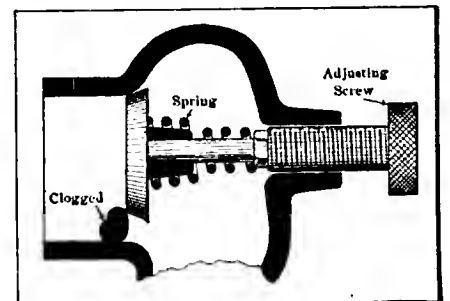

Fig. 4—Point at which the air valve of carbureter may be choked

## Finding Weak Spots in the Car

THE weak spots of a car are not always parts that are directly connected to the driving mechanism, but are frequently the little adjuncts which may be considered luxuries, rather than necessities, so far as the actual capacity for travel of the vehicle is concerned. These auxiliary fittings are often of a nature that renders them necessities; but when the more vital parts of the machine are well cared for, it suggests a great lack of thoroughness on the part of the responsible parties if these parts are neglected to such an extent that they do not compare with the other parts of the car in appearance, material or adjustment.

A lack of cleanliness may go a great way toward destroying the efficiency of a given part. Take, for instance, the brakes. It very often happens that oil will leak into the brake bands of a car. This oil will flow from the differentials into the brake drums by means of the rear axle, and will collect there, forming eventually into a thick gum or paste, which gives the brakes a marked tendency to slip. A case where a grease-filled brake drum very curiously brought about its own destruction is illustrated in Fig. 2, where a drum is shown which was broken in a collision. The brakes were jammed on as the emergency of a rapidly approaching car on a narrow turn arose, and, on account of the thick coating of grease with which the brakes were covered, the car swerved and collided with the other vehicle, thus incurring the damage shown.

The mudpan has nothing to do with the running qualities of a car, but if swung too low it may have a very nasty tendency to drag and bump along the road, reducing itself in a very short space of time to a shapeless mass of metal, which will make the most handsome car appear a very slovenly outfit. In Fig. 1 a case is shown where the pan was submitted to the vagaries of a rather irregular highway, and as a result was soon reduced to



Fig. 1—Battered mudpan which was swung so low that it struck the road

the state depicted in the illustration. When the pan is fitted it is not with the desire of removing the high spots from a bad road, but as a matter of precaution in the desire to protect the motor from the dirt and dust of the highway. In fitting the pan a little perspicacity should be employed, and where very rough going is to be encountered it should be fitted with due regard for the necessary clearance. In foreign travel, especially in France, where the roads are as a rule very flat, the low clearance allowable very often deceives those who come from abroad to tour in this country, and in many instances the low suspensions of the foreign cars render them unsuitable for transcontinental touring in this country.

In the case of frame members and springs, which are classified

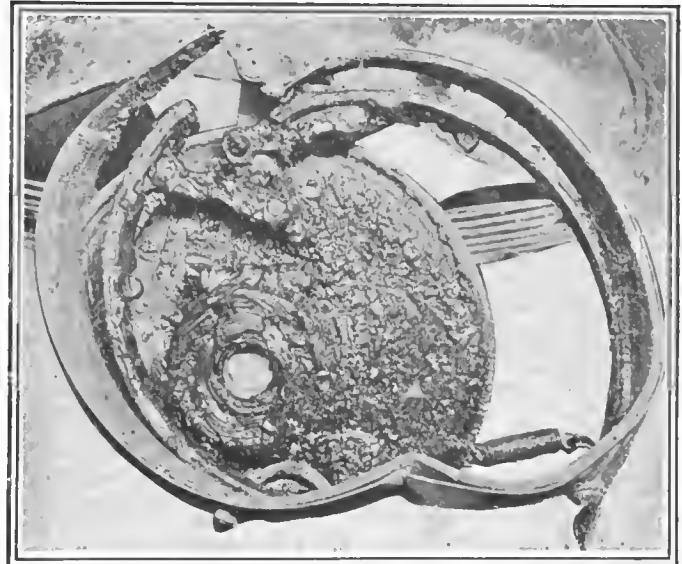

Fig. 2—Broken brake. Note the thick coating of accumulated grease

in the mechanics of materials as "simple beams," the greatest stress in the material is at the longitudinal center between supports, and therefore the metal which composes the various leaves of a spring is generally tapered so that it attains its maximum width at this point. In the case of frame members the same may be said to be true, though they are generally made of such sectional strength that a large factor of safety over their probable maximum load is given. It seems strange in the light of these facts that material should be cut away from the vital parts of a spring or other part of the mechanism without some compensating features in the way of added material or other strengthening device. When a spring fails it will be, as a rule, through the center of its length, and the failure will be caused by bending and tension, so that if a hole is drilled through a spring at this point it will be weakened in the very spot where the greatest strength is needed to resist failure. In Fig. 3 a spring is shown which was weakened by drilling a hole through the center. A bad spot in the road was encountered and the spring, as may well have been expected, failed at the point where the hole had been drilled.

In order that the best construction be maintained through any piece of mechanism an equality of strength should be maintained. That is, there should be no more weakness in the direction of compression than there is by tension or torsion. In designing the machine these strengths should be equated in order

to determine the correct thickness of the material; and in case any holes are to be bored for clips or holding-down bolts the weakening influence of the holes through the material should be included in the calculations. Each leaf of the spring is under both tension and compression when carrying a weight. This may be illustrated by taking for an example a plain plank resting upon two supports, one at either end. If a weight is placed upon the center of the plank it will sag and the upper surface of the plank will be compressed while the lower will be stretched or placed under tension. If this is not clear it may be easily demonstrated by coating the board with some non-elastic material and the effect of bending the plank noted upon the same. The tension and compression in the spring are both at a maximum at the center of the plank, as they would be in the spring, and it can readily be understood that accidents such as that shown in Fig. 3 may be expected where the hole is drilled and no compensating material added to this vital part.

The loose fan bracket is rarely the fault of the builder so much as that of the subsequent proprietor of the car. It will generally manifest itself by a sort of rattling sound which it gives forth as the car is proceeding on its way. If this noise is taken cognizance of at once, the fact that the fan hits the radi-



Fig. 3—Spring broken from excessive strain. Note position of bolt hole

ator as it revolves will be noticed in time to prevent the demolition of the fan. When the fan is driven by belt the bracket will often work loose after the car has been driven for some time. The result of a loose bracket is shown in Fig. 4, and, as may be seen, the fan is beyond repair.

Noise and its accompanying imperfections are rapidly being eliminated from the automobile, and smooth-running qualities are being substituted for the minor faults that cause the small annoyances which will occasionally be exposed. Progress in the lines of construction is still on the march, and in the elimination of noise and other sources of inconvenience the greatest steps in advance are being made. In the early days the fact that the motor would run for a large number of miles without a hitch was considered the greatest factor in the development of the car, and all other things were naturally secondary. Now that the number of roadside repairs has been reduced to the point that they consist almost entirely of tire changes, greater attention is being given to the little refinements which tend to the bettering of the running qualities and the silencing of the motor.

The matter of carrying tools has been given considerable attention in the later models of cars, and the ideas of the makers vary to a large extent on this detail. The placing of tool boxes on the running board has not met with the approval of a number of people who drive cars. It is also inconvenient to have the tools placed in such a position that the passengers in the car

will have to get out upon the road in case a stop is made to effect a minor repair.

The placing of the different appurtenances of the car has not so much to do with its well-being as the adjustment and fitting of these details when they are placed upon the machine. A squeaking body is just as annoying as a noisy motor even if it does not give the same indication of weakness and faulty design. The manner of supporting a weight should be sufficiently stiff to hold it against the vibrations of the car, and in the fitting of accessories of any description the method of fastening the same should be made a matter of great care on the part of the person who is doing the work. As mentioned above, the derangement of a minor part may often be of great influence in destroying the action of the entire machine, and the derangement is generally due to either inadequate fastenings or, as in the case of the fan bracket mentioned, the facilities for holding the part may be entirely adequate, but through neglect the holding-down bolts or other parts may become loose and the integrity of the part destroyed.

The greatest enemy to the best efficiency of a motor is inaccessibility, for it is in this that the reason lies that the adjustments are not made. Very often a slight knock, which would be adjusted immediately if it were easy to reach the affected part, is allowed to continue until a permanent weakness is developed in the motor and extensive repairs are necessary to restore the motor to its original condition. An inspection cover fastened over parts which are subject to wear or other damage will in many cases be the instrument of salvation to parts which would otherwise rarely if ever be examined.

There are some defects in a car which may gradually develop without the cognizance of even the most careful driver. These generally terminate in a breakdown upon the road and may have results which are very serious. A sudden swerve may put a strain upon the steering knuckle, for instance, which may tax it very nearly to the limit of its capacity. When this strain due to the swerve is supplemented by the shock caused by a rut a break would be very apt to ensue which might result seriously if the car were traveling at a rate which rendered it impossible to stop immediately, for a broken steering knuckle is distinctly beyond the scope of roadside repair.

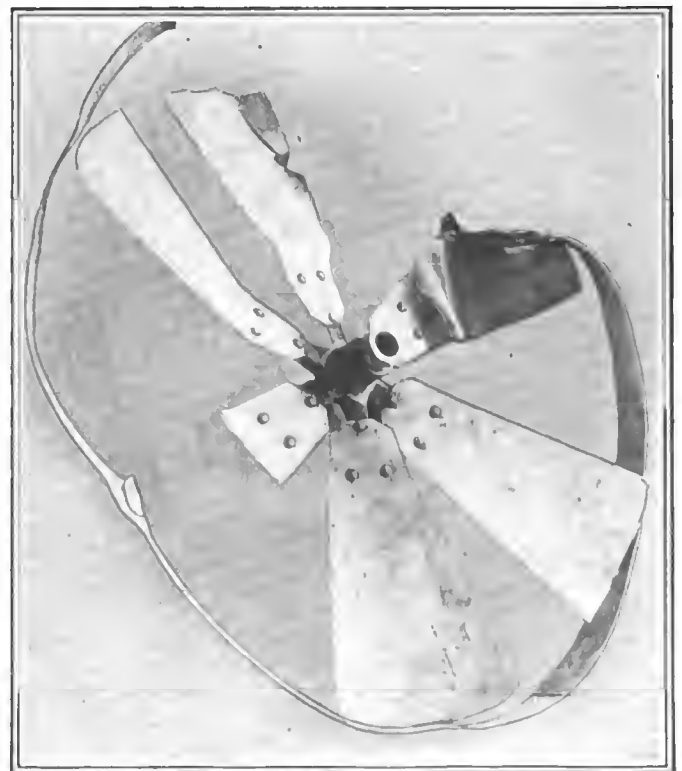

Fig. 4—Showing a demolished fan which resulted from a loose fan bracket

# Little Bits of Motor Wisdom

## Pertinent Pointers for Repairman and Driver

**O**UTFITTING THE HOME SHOP—One of the most fascinating pursuits to those who are in any way mechanically inclined is to spend a rainy day in the shop making the repairs that seem to be necessary and the little refinements which, although not a necessity, add greatly to the well-being of the car. The home shop may vary from a mere barn with a few commonplace tools to the elaborately fitted building with a

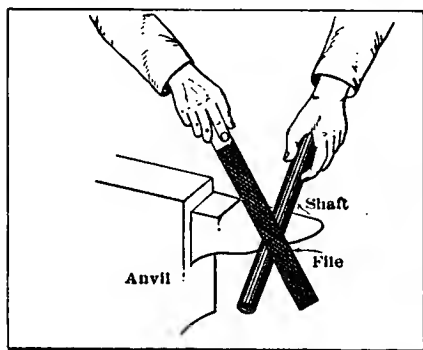

Fig. 1—Illustrating method of decreasing the diameter of a shaft by hand

forge and power machines. The latter will, of course be an extraordinary case, but between the two there is a range which will include any shop which the private owner may install.

There are many operations which can be performed with the ordinary tools of which the average owner will be possessed; that is to say, the tools which are not operated by machinery, but which depend entirely upon the handiwork of the operator. These will include the bench tools such as files, chisels, a vise, valve-grinding equipment and all the other appurtenances of the ordinary home shop. A few heavy tools may also be among the outfit if large repairs are to be occasionally undertaken. The most useful among these larger tools will be the forge and anvil, as many repairs which could be very easily made by the car owner or the private chauffeur, if the garage or shop were equipped with some apparatus for heating the metal, will otherwise have to be sent out. The garage is usually equipped with a gasoline torch, with which most of the small jobs such as soldering, etc., can easily be performed; but for other and larger work the torch is inadequate.

After the bench tools and the forge the next in order of importance is the lathe. The lathe may, in a great many ways, be more important than the forge, but since

the installation of a driving plant is necessary before the lathe may be properly operated it involves quite an expense and one which would not be justified unless the owner intended to do a large amount of work. There are so many duties to which a shop could be put, by the out-of-town proprietor, especially, that such an expenditure would no doubt be justified, inasmuch as the same machinery for driving the power plant could be used in pumping water, churning and all the various operations consequent upon the upkeep of the country house. Electric lighting is used in the modern suburban house, and when such is the case the same current which supplies the house could be carried to the garage and employed to drive the machinery installed.

A lathe, drill press and blower fan for the forge could all be operated from the same motor to good advantage, and the same belting could be used to operate the pump and the churn. When installing the belting and machinery, the work should be done by one who is an expert in the line, as the subsequent saving of time and space, not to mention the factor of safety, would well repay the extra expenditure involved in the employment of a capable man. The manner of arrangement of a shop and its lighting will determine to a large extent the time and cost of making the various repairs. This is just as much proportionately, in the case of the home shop as it is when the larger calculations of the manufacturing plant are involved.

The bench should be as long as the confines of the shop will allow and should be well equipped with vises. It should be divided so that certain classes of work are carried on at fixed parts of the bench and the corresponding tools so arranged as to be handy for the class of work to which they are adapted. If vises are clamped to the bench at about three different places along its length they will go a long way toward saving the time and steps of the person who is making the repair.

**THE GRINDSTONE**—The dull-edged tool is the most unsatisfactory thing to be encountered in the shop. It is dangerous to handle owing to its marked tendency to slip and inflict a gash upon the user, and it is unsatisfactory in regard to the quality of work produced by its use. A dull tool, although not adapted to the cutting of material, is in every way fully qualified to inflict an ugly wound upon a human being and should hence be dispensed with.

The primary instrument in the grinding of tools is the grindstone. The grindstone is driven either by hand, pedal or power through a belt. When driven by hand it requires two to perform the tool-sharpening operation and is for this reason very unsatisfactory. The hand-grinding instrument can readily be changed to the pedal variety, which is a step in advance. The last and best, the power-driven stone, is generally found in shops which are equipped with other motor-driven tools. There is always a method of feeding water to the surface of the stone while it is performing its work. In the hand-driven variety the person turning the stone has the added duty, as a rule, of occasionally pouring water from a handy can upon the surface of the wheel. Or, as is generally done in the foot-propelled variety, a bracket is arranged and the can hung upon it; a hole is then punched in the bottom of the can, which allows the water to leak through fast enough to keep the stone thoroughly wet. In the power-driven wheels the water is generally led through a pipe with a valve by means of which the supply of water may be varied to any degree.

The stones in common use are composed of a gritty form of sandstone known as English, Nova Scotia, Ohio and Huron

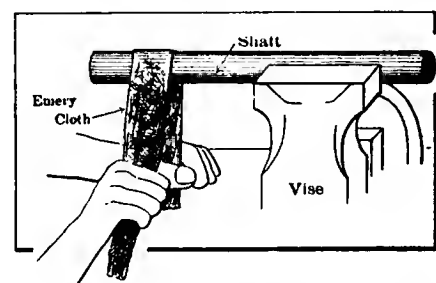

Fig. 2—Rubbing shaft with emery cloth when work is done without a lathe

varieties. The stone should be of uniform composition, fairly soft and coarse, and when used should be revolved so that about 500 linear feet of stone pass the edge of the tool in a minute. This would mean about 80 revolutions per minute of a stone of 2 feet diameter. In the case of a hand-revolved stone it would require a man of very fair strength and endurance to maintain this surface velocity for the length of time required to complete any extensive grinding. Although water is employed on the stone while it is performing its work, it should be turned off the minute

the work is completed and never be allowed to flow upon the stone while it is not in use. The stone should be kept in a warm, dry place, but not exposed to the rays of the sun, as this will harden the stone to a great degree and do it material harm, as it is at its best when soft.

A tool rest, generally clamped to the frame of the grindstone should be provided, against which the work is held while the operation of grinding is taking place. The stone should always be turned toward the operator and the tool to be ground placed against the tool rest. The motion of the grindstone will tend to pull the tool down with it, but the rest will take up this pull, allowing the operator to confine his attention to the edge of the tool.

On the power-driven wheels there is generally a truing device clamped to the opposite side of the frame from the tool rest. When it is desired to true the wheel the device is brought against the face of the stone and held in position by the clamp. When there is no truing device fitted, the adjustment may be made by hand by placing a piece of pipe or an old file edgewise against the wheel, having it rest upon the tool rest and moving it slowly back and forth across the face of the wheel while it is revolving. No water is played on the wheel during this process.

**SHARPENING TOOLS**—All edged tools require an occasional sharpening to maintain their condition and efficiency. Tools should not be put away while dull, but on the completion of a piece of work if they have lost their edge they should be ground or at least worked upon an oil stone if that is all that is required.

In grinding a tool the grindstone is set

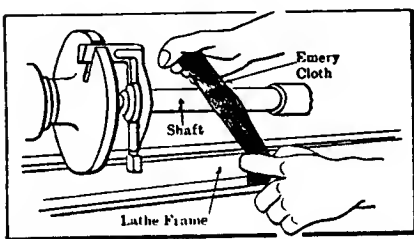

Fig. 3—Method of applying emery cloth to shaft when reducing the diameter

in motion so that it is turning toward the person performing the operation. The tool is then grasped firmly and placed across the tool rest at the proper angle. This angle must be maintained during the whole operation of grinding the tool, as it would be very detrimental to the quality of the edge obtained if the tool were to be shifted a number of times during the operation. The tool rest should be brought very close to the wheel so that there is no possibility of the tool becoming wedged between the stone and the frame in a moment of carelessness or owing to some inequality in the surface of the stone.

After all these precautions have been observed the tool is brought to bear lightly against the stone with the fingers placed in such a way that the delicacy of touch required in careful grinding is obtained. The heel of the edge is made to touch the stone first, and then the tool is tilted up until the correct angle is obtained. The tool is then held steadily at that angle and worked slowly back and forth against the surface of the stone so that any wear on its surface will be made as uniform as possible, otherwise there will be a marked tendency to wear grooves into the stone, which would greatly interfere with the accuracy of the work.

After having ground the tool to the required edge it is plunged into water and then worked across an oil stone or other fine stone which will put a finished edge on the tool. Lathe and special tools require special processes, according to their shape and use.

**FITTING OF PARTS**—In the careful fitting of parts, which is often necessitated when extensive repairs are undertaken in the private shop, it is sometimes a question whether the more delicate operations should not be sent out to better-equipped shops for more experienced hands to do the work. There is no doubt that in careful fitting, where the work must be exceedingly accurate in order to obtain the best results, the more elaborate tools will make the work much easier to perform. If the fitting of a shaft were taken for example, it would seem that in order to bring it down to correct shape it would first have to be filed, as shown in Fig. 1, and then, after this long, tedious work is finished, a piece of emery would be called into service to finish the work, as shown in Fig. 2. In hand-filing the shaft, the work could be laid across an anvil or a vise and lightly filed while the shaft was continually turned by the hand, in which it is held. After it had been brought approximately to shape by this method, which is depicted in Fig. 1, it would be placed in a vise and a piece of emery worked across the metal to remove the inequalities which would have resulted from the filing process. When using the emery cloth a long strip should be taken, as shown in Fig. 2, and rubbed across the shaft from one end to the other. The shaft should be frequently turned so that the same amount of material will be taken off on all sides. The shaft is then calibrated along the length required and any apparent inequalities removed.

If the same process were to be carried out with a lathe, the operator would merely have to center the piece of shaft to be turned down, set the tool so as to perform the work, and put the lathe in motion. The lathe is so arranged that the tool is carried slowly along the work in a plane parallel to the axis of rotation of the shaft and always at a uniform distance from it. At the end of this operation the shaft will

have been turned down to the thickness desired by the operator. If it is not required to take very much metal off the shaft it is merely necessary to use the emery cloth. The shaft is allowed to rotate at high speed and the emery held against it as shown in Fig. 3. If a fair amount of metal is to be taken off, the emery cloth may be of the coarse variety at first and afterward supplemented by cloth of a finer quality. In using emery cloth which is coarse, great care must be taken that it is not used too long, for if this is done scratches will be made so deep that they will be found in the finished product. Where great care is not so essential, and still a fairly uniform amount of metal has to be taken off the surface of the shaft, it may be placed in the lathe and rotated,

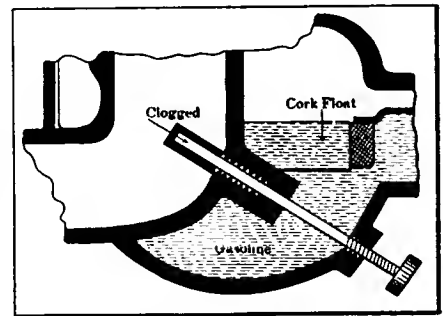

Fig. 4—Section through carbureter, showing needle valve which is apt to clog

with a file held lightly against the surface. Frequent calibration should be resorted to in this case in order that the work be done as uniformly as possible.

There are many other cylindrical parts which may be placed in the lathe for polishing as well as turning down. This is the case only with cylindrical parts, however, as owing to their shape the polisher may be merely held against them as they rotate in order to accomplish the desired result.

**WATCH CARBURETER NEEDLE VALVE**—The carbureter needle valve is about the most delicate part of this piece of mechanism, inasmuch as it is very apt to become clogged on the slightest provocation. The ounce of prevention in this case is to carefully watch and strain the gasoline that is placed in the tank. The gasoline outlet pipe will no doubt be provided with some sort of screen to prevent the passage of particles of dirt through the gasoline line, but at times a minute particle will pass through the meshes of the screen and find its way into the valve. A piece of cotton waste will very often become lodged in the needle valve in this way and stop the motor. The needle valve is illustrated in Fig. 4, which shows a section through a carbureter, and the clogging takes place at the point shown in the cut. The needle valve may be removed by unscrewing the knurled handle in a carbureter of this or similar type. A very fine wire is then passed through the orifice in order to free it of the foreign matter.



## Digest of the Leading Foreign Papers

**S**HARPENING OF TOOLS BY ELECTROLYSIS—The author points to the actual industrial uses of electrolysis or electro-etching as an indication that the same principle might be applied extensively for the sharpening of tools, but does not enter upon the question whether the acid would affect the properties of the tool steel as referred to in other recent research work. The effect of an acid on metal is increased when at the same time an electric current flows from the metal into the acid, the current always keeping the metallic surface clean for attack by fresh acid. This desirable current may be generated either by forming a galvanic element in the work itself by the addition of one or more pieces of charcoal and suitable wiring, or else, as has been found much more practicable, by connecting the metal with the positive and the acid with the negative pole of any independent direct current. In electro-etching the mass of metal etched away at any one spot depends not only on the duration of the etching and the acidity of the fluid but additionally upon the amperage per square centimeter which passes through the spot into the acid, and this amperage, which in turn depends upon the resistances in the circuit, cannot practically be brought under control unless an independent current source is used. The time required for a certain desired effect cannot be judged in advance with any degree of certainty. For this reason, and also because the acid affected the charcoal and produced a coat of mud over the work which had to be cleaned off at intervals, the methods used by Barthel in New York many years ago for sharpening flat tools and milling cutters by electrolysis in a bath which generated its own current did not prove altogether successful despite of great ingenuity in the arrangements. The change to the use of an independent battery has been universal, and for most purposes one of two to three volts is sufficient. When the current is thus generated externally there is also no need of using such sensitive material as charcoal in order to obtain a maximum of electromotoric force, but other more sluggish materials can be chosen. Grathwohl, of Herisau, Germany, thus uses lead for the cathode and sulphuric acid of 1.18 specific gravity for his patented method for restoring completely worn out files to usefulness by electro-etching. Hall and Thornton, of Birmingham, have produced sharp points on metal tubes and rods by connecting them with the positive pole of a battery and placing the end to be pointed in the acid solution, the latter being connected with the negative terminal, and then pulling the work out of the bath very gradually. The rods in this way became thinner and thinner toward the end. In the same manner thousands of needles could be pointed at the same time in a single trough by simply draining the acid off very slowly. A further development of tool sharpening by electrolysis is possible when the tool is not immersed in the acid solution but is brought in contact with it only where the etching is required. This may be done as follows: A piece of porous burned clay, shaped as the cutting edge to be produced in the tool, is soaked in the acid solution and connected with the negative pole of a battery and is pressed gently against the tool which is connected with the positive pole. After a little time the forming electrode is removed; the tool is brushed free from the alkaline crust which has been formed by the etching, and the forming electrode is soaked again with the acid solution and is again pressed against the tool. With a machine working on this principle the Electrogravüre Company, of Leipsic, has etched whole bas-relief friezes in metal. Burdett, of Hartford, etches ornamental designs and inscriptions into knife blades and metallic surfaces generally by the following method: The surface is painted with a mixture of 101 naphtha, 0.125 kilogram carbonate of sulphur, 2 kilograms powdered resin and 1.5 kilograms of chlorid of copper, and into this coat the de-

sign is pressed by means of a die which before each operation is cleansed in a potash solution. Parts of the coat which are loosened by the application of the die are washed off with water and the whole coat is then painted with a weak solution of ammonia or brine; then a clean smooth metal plate is laid upon it and is connected with the negative pole of a battery while the work is connected with the positive. The electric current now passes exclusively along those depressions or lines in the resin which were made by the die and are filled with electrolyte and, shortly, the design is etched out sharp and deep. The surface is then washed clean with a soda solution. Simple arrangements suffice even for work on a large scale.—Erich Schneckenberg in *Werkstattstechnik*, August.

**CEMENTING STEEL WITH OTHER SUBSTANCES THAN CARBON** (from an article on the Theory and Practice of Casehardening to Date by the well-known authority, Léon Guillet)—If chromium, tungsten, molybdenum or vanadium could be introduced superficially in iron or steel, tool steels and construction steels of high grade could perhaps be produced at a low cost (the machine work being done on soft material and the quality raised by the introduction of alloys, as carbon is now introduced by the casehardening process). Leaving aside the different false ideas which have gained currency, relating to the employment of nickel salts, of chromate of potassium, etc., it is now being assured us from divers sides that, so far as tungsten is concerned, the problem has been industrially solved. The author does not know either the method followed or the results obtained, he says, but only repeats a rumor persistently heard. [In the United States a large company is in the process of formation which is to undertake the "infusion" of several other alloys besides tungsten, and to transform pieces shaped from common Bessemer steel or even from wrought iron or pot metal into corresponding pieces possessing all the properties which could have been secured at higher cost by using high-grade alloy steels for the manufacture of the parts in the first place; and the company exhibits a large variety of parts and tools, including milling cutters, which have been obtained from many different manufacturers and have been so transformed.—Editor.]

The experiments which the author has made to obtain the penetration of nickel into steel have produced absolutely negative results. He has nickeled pieces of steel and has left them in a furnace at 1000° without any effect, even after very prolonged heat. He has also sought to employ "nickel-carbonyl," but the low temperature at which this substance decomposes and the dangers incidental to its use made him abandon these trials. Experiments with iron and aluminum, on the other hand, which were undertaken on the advice of Henry le Chatelier, gave very plain penetrations. A piece of aluminum fitted in the center of a piece of hollow steel showed considerable penetration at a heat of 450°, which is far below the fusion point of aluminum. But it does not seem possible to derive interesting industrial results from this fact. Copper, in very recent tests, gave a slow penetration, recognizable by the microscope, however. All this shows the way to important research, and the difficulty is assuredly to find suitable gaseous compounds or else to make sure by other means of close contact between the steel and the substance one wishes to bring into "solid solution" therewith. These difficulties are in reality the same which are experienced when it is attempted to dissolve pure carbon in iron (instead of using the bonemeal or other casehardening compound).

With regard to other metals than iron, the formation of a solid solution of one metal or substance with another seems theoretically plausible whenever the two substances are com-

pletely miscible. The only actual experiences in this direction which the author can cite are the following: A bar of bronze containing 7 per cent. of tin was fitted closely in a tube of bronze containing 16 per cent. of tin. After heating to 800° for 8 hours, the bronze originally containing 7 per cent. of tin showed a tin content of 9 per cent. (corresponding to the "delta" class under the spectroscope), and the tin content increased toward the joint between the two bronzes, just as pearlite in a cemented steel. Again, a condenser tube of "alpha" brass which had been tinned showed, after a heat which probably did not exceed 150° C., the characteristic "delta" constituent of tin-brasses. The author repeated this experience, heating an "alpha plus beta" brass of 60 per cent. copper after having tinned it, and then saw in the black zone of "beta" the "delta" constituent which is characteristic of the presence of tin. Finally, Mr. Masiny has shown, by the variation in electric resistance, that lead and thallium, when brought in contact, penetrate mutually, beginning at ordinary temperatures, and that the speed of penetration is clearly emphasized at a temperature of 100° C. The industrial process known as "sherardization" belongs in the same class of phenomena. It consists in placing steel forgings or castings in commercial zinc powder at a temperature of 300° C. The result is a "galvanizing" of very pretty patina and very durable, and trials have demonstrated that the process is one of real cementation by the solid (though powdered) zinc, taking place only where the powder and the steel are in real contact.

Only 15 years ago, says the author in summarizing his treatise on casehardening, a trough heated with coke was placed on the floor of the shop and the pieces to be hardened were stuck into a queer powder compounded from cows' horns, hog suet and urine, but it has now advanced to be a scientific process to be practised under close observation of intelligent rules for adapting means to ends.—*Le Génie Civil*, August 5.

ACETYLENE GAS EASY TO IGNITE IN RICH OR POOR MIXTURES—According to experiments conducted by Prof. Eilner, a mixture of air and acetylene gas begins to be explosive at a 2.9 percentage of acetylene, and the explosiveness continues up to a percentage of 64. Other experiments on a much larger scale by the Electrical Society of Bosnia place the low limit for explosibility at 2.5 per cent. to 2.6 per cent., and at 3 per cent. the explosions became violent enough to shake the solid masonry

which confined 11 cubic meters of the gas mixture and had been erected for the purpose of the experiments.—From *La Rivista tecnica d'Italia*.

VIENNA'S FOUR-IN-ONE MUNICIPAL MOTOR WAGON—The municipality of Vienna has acquired a motor vehicle of a new type which can serve as a sprinkling wagon, a fire engine, a street sweeper and as a simple 6-ton truck. To transform the sprinkling wagon into a fire engine it is only necessary to start a separate motor, operating independently of the motor power, and to attach a fire hose to a universal screw plug on the pump. A simple movement lets down the sweepers which operate like the snow ploughs of the street car companies, and when the water reservoir is dismantled, the city has at its disposal an ordinary 6-ton truck.—*Automobile-Aviation*, September 21.

BOOM FOR HEALTH RESORTS BY EXCLUDING THE FLY BREEDERS—"We should like to propose to some landowner who is anxious to found a seaside resort that he should try the experiment of making it into a real health resort by banishing the horse from its precincts. Nowadays public opinion is sufficiently advanced to realize the benefits of air free from impregnations of animal filth, and we believe there are distinct possibilities in a horseless health resort. We do not merely mean possibilities of health, but possibilities of establishing a town which would be appreciated, and to which visitors and seekers for health would betake themselves simply because they would realize that proper precautions had been taken to preserve the air from contamination."—*The Autocar*, Sept. 16.

EUROPEAN AGRICULTURAL INTERESTS DEMAND MOTOR IMPLEMENTS NOWADAYS—The French Association for Motor Agriculture (*Association Française de Moto-Culture*), recently held a competition for agricultural automobiles at Melun. The machines represented were: One tractor of 25 horsepower, which turned over the soil when hitched to a plough with five shares and with equal facility actuated a harvester with three binders; one tractor for heavy work; one winch-truck; one automobile disk-plough; one automobile breaking-plough; two self-propelled hoeing machines and two self-propelled cultivators.—From *L'Automobile Belge*, August 30.

# Calendar of Coming Events

**Shows**

- Oct. 7-14.....Chicago, Ill., Show of Chicago Automobile Trade Association.
- Jan. 6-13.....New York City, Madison Square Garden, Twelfth Annual Show, Pleasure Car Division, Automobile Board of Trade.
- Jan. 6-20.....New York City, Madison Square Garden, Annual Show, Motor and Accessory Manufacturers.
- Jan. 10-17.....New York City, Grand Central Palace, Twelfth Annual Show, National Association of Automobile Manufacturers; also Motor and Accessory Manufacturers.
- Jan. 15-20.....New York City, Madison Square Garden, Twelfth Annual Show, Commercial Division, Automobile Board of Trade.
- Jan. 27-Feb. 10....Chicago Coliseum, Eleventh Annual Automobile Show under the auspices of the National Association of Automobile Manufacturers. Pleasure cars, first week. Commercial vehicles, second week. Accessories, both weeks.
- Feb. 19-24.....Hartford, Conn., Annual Show, Automobile Club of Hartford, State Armory.
- March 2-9.....Boston, Mass., Tenth Annual Show, Boston Automobile Dealers' Association, Inc.
- Meetings, Etc.
- Nov. 20-24.....Richmond, Va., First American Road Congress, under auspices of American Association for Highway Improvement.
- Nov. 23.....Road Users' Day, under direction of Touring Club of America.
- Jan. 18-20.....New York City, Annual Meeting of the Society of Automobile Engineers.
- Race Meets, Runs, Hill-Climbs, Etc.
- Oct. 7.....Danbury, Conn., Track Races, Danbury Agric. Soc.

- Oct. 7.....Springfield, Ill., Track Races, Springfield Automobile Club.
- Oct. 9-13.....Denver, Colo., Reliability Run, Denver Motor Club.
- Oct. 10.....Bedford, Ind., Hill Climh.
- Oct. 11.....Oklahoma City, Okla., Reliability Run, Oklahoma State Automobile Association.
- Oct. 12-13.....Peoria, Ill., Track Races, Peoria National Implement and Vehicle Show.
- Oct. 14.....Santa Monica, Cal., Road Races.
- Oct. 14 (to 25)....New York City, Start of the Annual Glidden Tour, en route for Jacksonville, Fla.
- Oct. 16-18.....Harrisburg, Pa., Reliability Run, Motor Club of Harrisburg.
- Oct. 21.....Atlanta, Ga., Track Races.
- Oct. 27-Nov. 3....Chicago, Ill., Thousand-Mile Reliability Run, Chicago Motor Club.
- Oct. 31.....Shreveport, La., Track Races, Shreveport Automobile Club.
- Nov. 2-4.....Philadelphia, Reliability Run, Quaker City Motor Club.
- Nov. 3-4.....Columbia, S. C., Track Races, Automobile Club of Columbia.
- Nov. 4-6.....Los Angeles-Phoenix Road Race, Maricopa Auto Club.
- Nov. 9.....Phoenix, Ariz., Track Races, Maricopa Automobile Club.
- Nov. 9, 10, 12....San Antonio, Tex., Track Races, San Antonio Auto Club.
- Nov. 27.....Savannah, Ga., Vanderbilt Cup Race, Savannah Automobile Club.
- Nov. 30.....Los Angeles, Cal., Track Races, Motordrome.
- Nov. 30.....Savannah, Ga., Grand Prize Race, Savannah Automobile Club.
- Dec. 25-26.....Los Angeles, Cal., Track Races, Motordrome.

**Foreign Fixtures**

- Oct. 12-22.....Berlin, International Automobile Exhibition.
- Nov. 3-11.....London, Eng., Olympia Show.

# THE AUTOMOBILE

Vol. XXV

Thursday, October 5, 1911

No. 14

## THE CLASS JOURNAL COMPANY

H. M. SWETLAND, President

CONDE NAST, Vice-President and General Manager

E. M. COREY, Secretary and Treasurer

231-241 West 39th Street, New York City

Cable Address - - - - - Autoland, New York  
 Long Distance Telephone - - - - - 3046 Bryant, New York

### SUBSCRIPTION RATES

United States and Mexico - - - - - One Year, \$3.00  
 Other Countries in Postal Union, including Canada - - - - - One Year, 5.00  
 To Subscribers—Do not send money by ordinary mail. Remit by Draft,  
 Post-Office or Express Money Order, or Register your letter.

Entered at New York, N. Y., as second-class matter.  
 The Automobile is a consolidation of The Automobile (monthly) and the Motor  
 Review (weekly), May, 1902, Dealer and Repairman (monthly), October, 1903,  
 and the Automobile Magazine (monthly), July, 1907.

## Our Babies

THE progress of automobile design in America has been hampered by the babies of the engineers, by the babies of the factory heads and by the babies of some influential stockholders. There is scarcely an engineer but has had his babies in the field of design. Each has had his pet designs. One engineer started out with a method of controlling valves in the early days of the industry. He conceived the idea and consequently held on to it until the wolf was near the door. Sheer necessity then made him give it up. The giving up of it was like amputating a part of himself. He had nourished it from its inception; to him it was the only method of control that could be right; it was the type that would exist when all others were forgotten; and he could see no other one. Other makers controlled in the carbureter; the public of France at that time demanded throttle control; it was gaining on every hand; but the engineer stuck to his baby until it was a case of give it up or get out. He deserted it.

The babies of the automobile industry have not all lived in France—America has had a good many of them. One engineer had his own type of axle; he took out the patents on it; he manufactured it; he introduced it, and he died for it. He had eyes for it and for nothing else. The design was passably good; it gave a measure of satisfaction; but it was not what the masses wanted. The engineer dictated the policy of the factory; he was the Alpha and Omega of everything pertaining to engineering in that company, and the company stuck to the axle and to the engineer until its sales dwindled and dwindled. One after another of its best men joined other more progressive companies, but still the engineer and the factory stuck to the baby. At last money became so scarce that it was death or the baby; then, and only then, was the baby dropped. Since then the company has been slowly gaining. It learned the lesson: "Do not stick too long to the baby."

One factory manager preferred complete business extinction to the surrender of his baby. It was a method of control and body design. It was excellent; from the

scientific viewpoint nothing better could be wanted; but the people did not buy it. The business grew smaller and smaller; soon the factory force dwindled to a mere handful of workmen; new capital was looked for and secured—but the baby was retained; a month or so later the low mark was reached; a receivership ended the agonies. It was a double funeral.

One concern started in the manufacturing field of cars with triplets. It had a special ignition scheme, different from all others, and it took a salesman 15 minutes to explain it. The system worked well, but it was roundabout and had many needless parts. The car also had a cantankerous method of lighting the headlights from the seat. It, too, was different. According to the inventor it was going to revolutionize car lighting—but it failed. This automobile had a self-starter; self-starters are good, everybody is after them to-day, but in those days nobody wanted them. The engineer was going to make the people not only want them but use them—he failed. The company stuck to all three babies. The engineer had invented them all; they were dear to his heart and he would not give them up. The company soon afterwards failed.

But the babies of the automobile business are not all gone yet. There are scores of them still living and being guarded fearfully by the engineer, or the factory head. Some of them to-day are in the form of carbureter schemes; others are frame designs; some are lubrication contrivances; some are gearset eccentricities; some are brake designs; some body whims, and others steering features. These babies are all expensive. In many cases it has necessitated special machinery to manufacture the special parts. This machinery has cost money and so is an expense. The biggest expense of all, however, is in the expenditure of energy in selling the article. There are companies to-day that have their salesmen spend 25 per cent. of their energy in convincing the buyer on one point, the imagined value of the baby. This is poor policy; it is short-sighted policy. This policy was all right a few years ago when selling cars was confined to filling out orders, but it is not all right to-day. This is a day of competition. This is a day when salesmanship is needed and the best salesmanship will not sell machines with inferior designs. What is needed to-day is good design and not the whims of an engineer.

There are more whims and babies in many American cars than in many of the European types. The foreign car may show much in the line of versatility of design, but the whim is not so apparent. The reason is at hand: The majority of the big foreign factories have a corps of graduated engineers—they are not so scarce as in America. These engineers meet together and they meet with the directors of the company. They meet in hot discussions. One engineer may have his babies; he wants his pet designs incorporated into the car; the other engineers discuss and oppose it, and the net result is that pet ideas are eliminated to a much greater extent than in a factory, like so many of the American factories, where the engineer is the only person who has anything to say in the field of design. He has to be a gilt-edge engineer who can dictate all that is best for a car. He may be an expert in gasoline engine design but a pigmy when it comes to designing a steering gear; his principles may be excellent for brake design but wrong in gearset work. So it is all through the car which is the product of one man; the car is certain to have its weaknesses. A corps

of three or four engineers is always much better than one. These engineers can at least see the design, under question, from three or four different angles; one should be able to pick out some weaknesses that the others might pass over; a second one will be able to suggest some detail that when added will be an improvement; and so through the entire car. If a factory cannot support its corps of engineers it might be able to support a consulting engineer, or aid in supporting one. The calling in of other physicians is considered the best policy in cases of dangerous illness. Why cannot the same thing be tried out in car design? Some of the most progressive makers are doing it to-day and they are profiting and saving money by it. More will be doing it before two years have elapsed.

It is cheaper to employ two or three engineers than it is to pull a design to pieces every year or so. It costs money to make dies for forgings; it is expensive to change the cylinder designs and have to alter the patterns;

it is expensive to make new jigs each season, and it is expensive to buy new machinery or alter the old to take care of the annual changes. Many of the changes that are imperative each year are due to an overworked engineer, or to one with his pets. With the board of directors of the factory it is short-sighted policy to let a single engineer dictate, when the better judgment of many of the board says that certain changes should or should not be made. There are cases on record to-day where engineers are obstinate. They will not change because some other engineer has beaten them to a certain design. Such persons are equally dangerous. The solution is a corps of engineers or some good consulting engineers. Our factories are going to come to one or the other very soon. It is imperative with some of them; with others the policy will be dictated by good judgment. There are not a few wrecks on the sea of automobiling to-day, due solely to an engineer running away with the factory. The wise, far-seeing factory head is watching this problem.

## S.A.E.'s Foreign Trip

ARRANGEMENTS for the foreign trip of the Society of Automobile Engineers are occupying an important part in the thoughts of members of the organization. So far 37 have signified their intention to make the trip if possible and about half that number have definitely arranged to go. At the meeting of the organization Wednesday a tentative program was framed covering a visit of 23 days, as outlined previously. Howard E. Coffin will make an address in London on chassis design.

The place in which the annual meeting will take place in New York was considered and it is likely that the Automobile Club of America will be chosen again.

## Reeves Outlines Scope of Industry

Alfred Reeves, general sales manager of the United States Motor Company, in a lecture delivered before the West Side branch of the New York Y. M. C. A. recently, gave out the following statistics with regard to the automobile industry:

"155 factories are now beyond the experimental stage and producing 50 or more cars a year.

"65 companies are now producing motor trucks or commercial vehicles exclusively.

"405,000 cars registered as being in active use in the United States at the present time, with probably 50,000 more cars used where State registration is not required.

"190,000 cars sold during the past twelve months.

"210,000 pleasure cars scheduled for the next twelve months.

"9,000 trucks and delivery wagons now in use.

"18,000 trucks and package delivery wagons to be made in the next twelve months.

"11,400 dealers selling cars in every town of any importance in the country, with a very much larger number of garages.

"82,166 motor cars registered in New York State.

"32,400 chauffeurs registered in New York State.

"\$20,000,000 in motor cars and parts will be exported during 1912, based on Government figures for the first seven months."

## Outdoor Show at Mound City

ST. LOUIS, Oct. 2—An out-of-doors exhibit marked the opening of the fifth annual Automobile Show of the St. Louis Manufacturers' and Dealers' Association, which began at Forest Park Highlands, a summer amusement resort, Monday night. The early date of the show is due to the fact that the Veiled Prophet Festival is being put on the same week.

## Fire-Fighters Parade

THE budget display of automobile fire apparatus owned by the city of New York was held Tuesday in front of the City Hall. Eighteen pieces of apparatus were in line, including all those specified and described in a recent article in THE AUTOMOBILE. Aside from the actual fire-fighters there were a number of runabouts and raceabouts used by battalion chiefs and executive officers of the department.

Mayor William J. Gaynor reviewed and inspected the display. The present motor equipment of the fire department is a nucleus about which will be assembled a collection of at least 150 pieces of power-driven apparatus by January 1, 1913.

## Louisville Plans for Fire Automobiles

LOUISVILLE, Oct. 2—If the chief of the Louisville Fire Department, Timothy Lehan, has his way, the present fire-fighting equipment will be replaced by automobile apparatus. The contemplated change will be made as soon as the horse-drawn vehicles now in use wear out.

Louisville has twenty-one fire stations. At each an engine and hose reel is located. Besides this apparatus there are five hook-and-ladders and a water tower. The only motor vehicle now in use by the department is the one used by the chief. The street railway company, the salvage company and the lighting company all answer alarms in motor-driven vehicles.

According to the chief, one of the advantages of the motor apparatus is that the engine and hose cart can be combined, and some companies are now turning out a successful combination consisting of engine, hose cart and chemical engine.

## Knight Entertained at Indianapolis

INDIANAPOLIS, Oct. 2—Charles Y. Knight, inventor of the silent Knight sleeve-valve motor, was the guest of motor car men at the Columbia Club in Indianapolis, on the night of Sept. 20. The occasion was a dinner given in Mr. Knight's honor by Hugh H. Hanna, president of the Atlas Engine Works, which has been licensed to build the Knight motor for the trade in the United States.

Mr. Knight spoke at length of the inception and development of his motor. F. E. Lonas, legal representative of the Knight & Kilbourne Company, was also among the speakers. Mr. Knight's father resides in Indianapolis, and he spent a few days with him, during which he consulted with the officials of the Atlas company relative to the building of the Knight motor.

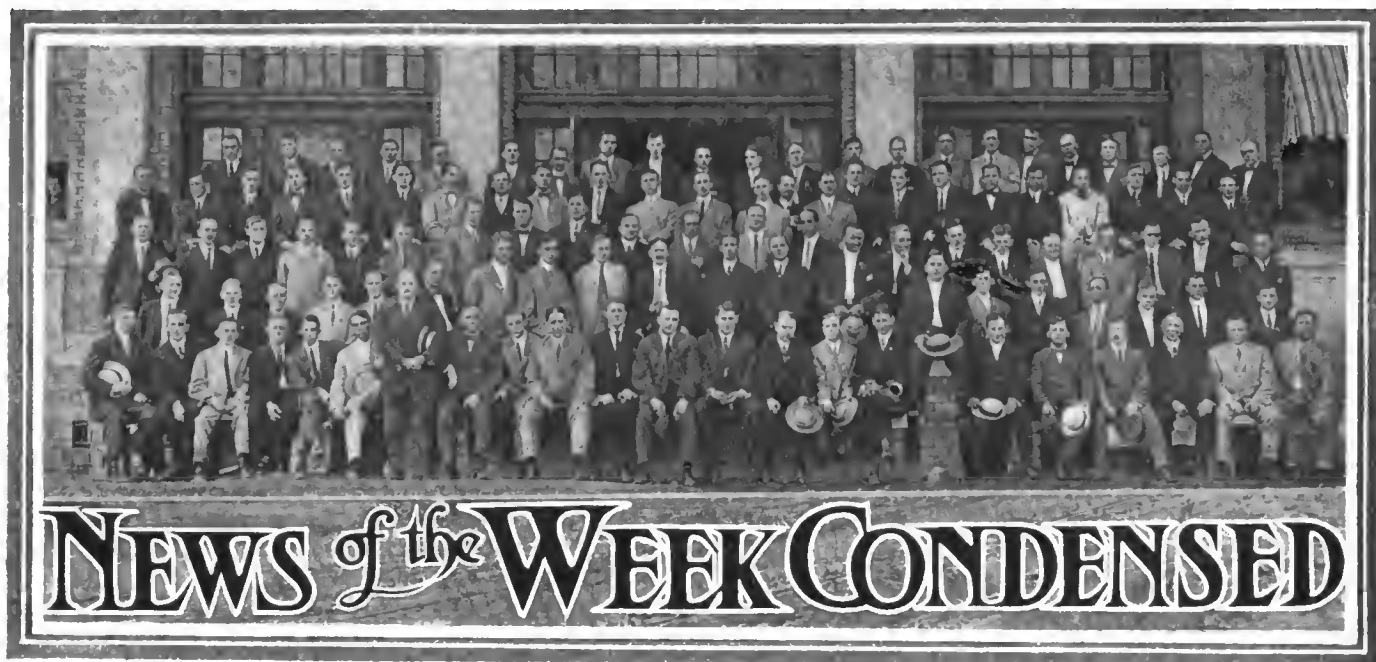

**A** KRON, O.—More than 100 representatives of the sales force of the Firestone Tire & Rubber Company were in annual convention here some days ago. President Firestone in his annual address submitted figures which indicated that last year's increase in sales was the greatest in the company's history. The above photograph was taken in front of the company's immense new plant.

**SAN FRANCISCO**—The Frank O. Renstrom Company, local distributors for the Regal and Kline lines, has taken the coast agency of the Dart delivery wagon.

**CLEVELAND, O.**—The Standard Welding Company has opened a branch office at Chicago. The line was formerly handled by L. F. McClernan & Co. in that city.

**COLUMBUS, OHIO**—The Cummins Auto Sales Company, of North Fourth street, Columbus, Ohio, has closed the agency for the Everitt in six counties in Central Ohio for 1912.

**ZEELAND, MICH.**—The Zeeland Automobile Company has purchased a new location at Main and Washington streets. The company will move its old building to the new site immediately.

**GOSHEN, IND.**—Teegarden & Putt will occupy their new garage in that city this month. The new garage is located north of Hotel Hascall, and work is being rushed as rapidly as possible.

**INDIANAPOLIS**—Charles E. Coots, chief of the Indianapolis Fire Department, has asked the Board of Public Safety to purchase gasoline runabouts for each of the four assistant fire chiefs.

**CINCINNATI, O.**—The Heilman Motor Car Company is building a garage in Cumminsville. The new place will have facilities for handling 40 cars. The company sells the Haynes and Cartercar.

**PORTLAND, ORE.**—One of the most up-to-date and finest appointed garages here was recently completed for Thompson & Nation, Speedwell agents. It is located at Couch and Fourteenth streets.

**SOUTH BEND, IND.**—The Simplex Motor Car Company, of Mishawaka, Ind., has decided to enter two Amplex cars of the latest model at the open-air auto show which will be held in St. Louis, in October.

**DAYTON, O.**—H. P. Michael, formerly with the Miami Valley Automobile Company, has opened an agency at 16 South St. Clair street, and will handle the Hupmobile exclusively. He will install also a repair department.

**SEATTLE**—Arrangements were concluded last week by Paul McMullen, Oakland manager for the Hudson and Hupmobile cars, for the construction of a fireproof building at 1511 Broadway, to be completed in November.

**DAYTON, O.**—H. J. Myers, formerly sales agent for the Baker electric in this city, has been given the agency for the company at Cleveland. His territory includes Ohio, Southern Michigan, Western New York and Western Pennsylvania.

**WEST BEND, WIS.**—The West Bend Aluminum Co. has been incorporated here, with a capital of \$14,000. The company has established an aluminum factory in the old Kress factory buildings. Andrew J. and Edwin Pick and Martin Walter are the promoters.

**MARIETTA, OHIO**—The Pioneer Motor Car Company, recently incorporated with a capital stock of \$18,000, will soon start the erection of a three-story brick building, to be used as salesrooms and garage as well as a repair shop. The building will be erected on Front street, and will be 190 by 58 feet.

**OKLAHOMA**—Citizens of Grady County, Oklahoma, propose to build their proportionate part of the State road crossing that county in 1 day, October 2. A holiday has been declared for that day, and practically every man of the county has agreed to work that day on the road.

**COLUMBUS, OHIO**—The Rusk & Hallock Company, North Fourth street, Columbus, Ohio, has closed the agency for the Warren-Detroit for 1912, covering six counties in Central Ohio. The counties in the territory are Franklin, Delaware, Pickaway, Fayette, Madison and Union.

**ROANOKE, VA.**—The third annual convention of the South Appalachian Good Roads Association will be held here October 4-5. Logan Waller Page, Governors W. H. Mann, Cole L. Blease, Augustus E. Willson and a number of prominent engineering experts are scheduled to speak.

**NORTH JUDSON, IND.**—The Stark County Garage & Machine Works is erecting a garage here which will be the largest in Stark County. The proprietors are A. C. Ross, of Winamac, and G. A. Spohner, of North Judson. It is expected to have the building completed by the last of October.

**DAYTON, O.**—George L. Baker and Frank L. Baker have opened an auto livery service at 122 South St. Clair street. George Baker will remain in charge of the retail sales department of the Speedwell Motor Car Company, the new venture having no direct connection with his other work.

**SAN FRANCISCO**—One of the most interesting automobile changes here recently was the switching of the Apperson agency in Northern California from the Auto Sales Company to the Weeks-Covell Automobile Company, who are also the new Northern California distributors of the Pathfinder and Parry.



**PHILADELPHIA**—The annual meeting and banquet of the Automobile Club of Delaware County will be held in the new Armory Building in Chester, next Wednesday evening. New officers and directors are to be elected. The organization dates from 1906.

**PITTSFIELD, MASS.**—The Cortland Motor Wagon Co., formerly of Cortland, N. Y., is in its new plant at Pittsfield, Mass., and have the 1912 output well under way, the first car being on the road. The officers are as follows: R. H. Jadwin, president; Tracey A. Rudd, vice-president; Edson T. Starks, secretary and treasurer.

**DAVENPORT, IA.**—Hite D. Bowman, agent for the Rauch and Lang electrics, Stearns and Chalmers cars, has just completed a \$7,000 addition to his garage at Fourth avenue and Oak street. It is to be used exclusively as a place in which to charge, house and repair electrics. A workshop has been installed on the second floor.

**GRAND RAPIDS, MICH.**—The Palmer Sales Company has secured space with the Hupmobile garage on North Ionia street. Remodeling is going forward rapidly at the Overland Sales Company garage on Island street. George P. Dowling will become the Buick factory's territorial representative for Kent, Ottawa and Allegan Counties.

**VANCOUVER, B. C.**—Dr. Chas. G. Percival, of New York, in the Abbott-Detroit "Bull Dog," has reached this city, with a total mileage of 32,112 miles to his credit on his trip around the world. He has successfully completed the first authentic trip along the route of the Pacific Highway, from Tia Juana, Mex., to Vancouver, B. C.

**MONTREAL**—The Hupp Motor Car Company, which has for some time been assembling cars in leased premises at Windsor, Ont., has closed a deal for the purchase of a site including a little more than 3 acres. The company will erect two factory buildings at a total cost of about \$525,000, and will start with a force of 150 to 200 men.

**WASHINGTON, MO.**—At the Franklin County Fair, which was held last week, the Crow-Elkhart car owned by Dr. Otto L.

Muench, was awarded first prize for beauty of decoration, which consisted of 6,000 roses, ranging from deep red at the bottom to pink and white at the top, surmounted by a pair of butterflies driven by a little fairy.

**ATLANTA, GA.**—J. E. C. Edsall, representing the Staver-Chicago car, reached Atlanta this week after a round-about 2,500-mile trip from Chicago. He will for the present make his headquarters in Atlanta and will establish agencies in Georgia. There is reported to be a possibility that a Staver-Chicago branch may be opened in Atlanta.

**ATLANTA, GA.**—E. P. Horton, formerly representative of the United States Motor Co. in Syracuse, has been transferred to the Atlanta branch, and will hereafter have charge of the United Motor Atlanta Co. L. E. Kloeber, who has been manager of the Atlanta branch for some time past, will soon be transferred to some other U. S. Motor branch.

**COLUMBUS, OHIO**—The Hudson Sales Company, North Fourth street, Columbus, Ohio, has taken the agency for 1912 for the Whiting. The territory covers 16 counties in Central Ohio. Sub-agencies have been placed as follows: Springfield, Gaither Auto Co.; Circleville, Mader Auto Co.; Logan, Gage Automobile Co.; Newary, Charles U. Stevens.

**COLUMBUS, OHIO**—B. F. Myers, connected with the firm of Rusk & Hallock, has secured a patent on a spring shield which will be manufactured in Columbus, Ohio, by a corporation to be organized in the near future. The idea is to have pieces of heavy felt, containing oil, bound next to the spring by a leather casing which is laced from either axle.

**AKRON, OHIO**—The Olds-Oakland Company, of Cleveland, Ohio, has established a permanent agency for the Oldsmobile and Oakland lines with the Portage Motor Car Company, of Akron. D. W. Thompson, manager of the Portage Motor Car Company, will have personal charge of the distribution of the Oldsmobile and Oakland in Akron and vicinity for 1912.

**SOUTH BEND, IND.**—Montgomery County, Indiana, has some of the finest roads of the State. It has 134 improved roads, built of gravel or crushed stone. These roads were all constructed under the 1905 road law. The cost of constructing the gravel roads is from \$2,000 to \$2,300 per mile, while the cost of constructing the stone roads is from \$3,500 to \$4,000 per mile.

**SYRACUSE, N. Y.**—The third annual sociability run of the Syracuse *Herald* will be held Saturday, October 7, with Mayor Edward Schoeneck as an honorary referee. It is expected that more than 200 cars, many of them driven by women, will participate. A 60-mile run through a picturesque farming country southeast of Syracuse has been arranged, the turning point being at Tully.

**DAVENPORT, IA.**—The Buck Motor Car Company, agent for the Packard cars, Packard truck and Detroit electrics, has just moved into a new \$13,000 garage. The new Packard and Detroit electric headquarters in Davenport is 45 by 140 feet in dimensions, constructed of terra-cotta and concrete with brick front, with handsome offices furnished in oak and a show room with a capacity of ten cars.

**MILWAUKEE**—H. L. Kuelling, C.E., University of Wisconsin, '06, has been elected Highway Commissioner of Milwaukee County, Wis., under the new State aid for highway improvement law. As County Highway Commissioner he will supervise the expenditure of an appropriation of \$100,000 made by the Milwaukee County Board of Supervisors for road work, which draws an additional \$75,000 from the State Treasury as State aid.

**SAN FRANCISCO**—One of the latest additions to Automobile Row is the Auto Tire Company. This is a branch of the New York firm of that name, which has its subordinate houses throughout the country. The San Francisco house has been established by R. A. Demarest, general manager of all branches. Mr. Demarest has lately established a similar branch house in Los Angeles. The San Francisco house will be in charge of N. C. Dunham.



Panoramic view of a recent tour in California in which only KisselKars took part. There were 22 cars in the 200-mile tour



New building of the Metzger Motor Car Company, at Detroit, Mich., now in course of construction. It is four stories high and 550 feet long

PHILADELPHIA—A meeting of the Board of Governors of the Automobile Club of Philadelphia was held this week, at which twenty-five new names were added to the membership roll and general plans for the proposed new clubhouse and garage of the organization discussed. It is announced that work on the latter will be started before snow flies. The treasurer's report showed the club to be in excellent financial condition.

LOS ANGELES—One of the most novel automobile displays ever projected in the country is under way under the direction of the Los Angeles Order of Mystic Shrine. The automobile show will be held at the Shrine Auditorium, November 6 to 18. Twenty Los Angeles dealers have taken space for the show. A popular voting contest will be held, at which an automobile will be given away.

SYRACUSE, N. Y.—Syracuse dealers in motor trucks are now waging a campaign of education among users upon the danger of the combination of overloading and fast driving. The argument is being made upon these three points, non-observance of which the agents contend seriously menaces the industry: 1. Mechanism suffers when normal carrying capacity is exceeded. 2. Tires wear down more quickly. 3. The life of a truck is shortened by its hard usage.

LOS ANGELES—A new automobile truck factory is to be built here. Announcement was made during the past week of the concern, which will be known as the Moreland Truck Company, organized by W. L. Moreland. The plant will be in operation in 60 days, according to the announcement, and will turn out what is known as a distillate truck from 1 to 5 tons capacity. The officials of the company are R. H. Raphael, president; C. Kubeck, vice-president; Sheldon Morse, secretary and treasurer, and W. L. Moreland, manager.

MILWAUKEE, WIS.—The Pauly-Bruce-Goldaker Co. has been organized to handle the Stoddard-Dayton line in Wisconsin. The State agency formerly was in charge of the McDuffie Automobile Co., of Chicago and Milwaukee. The Stoddard garage at 141-145 Eighth street, is now occupied by the Hickman-Lauson-Diener Co., State agent for the Ford, and the new Pauly company has taken the former Ford headquarters at 222-224 Fourth street.

PORT HURON, MICH.—The Havers Motor Car Company has closed a contract with one of the largest motor concerns in the country for the building of the Havers "Six" motors for the coming season. The contract amounts to approximately \$340,000. The company has been occupying about one-half of the plant formerly used as the Malleable Iron Foundry, and alterations are now under way that will make it possible to use the entire plant the coming season.

SYRACUSE, N. Y.—A number of automobilists and dealers from this city plan to accept the invitation of Secretary of State Lazansky to meet with autoists from all over the State at Albany on October 9, to discuss means of increasing interest in automobile touring. Representatives from many Eastern States will also be present, and a uniform statute for non-resident touring privilege will be discussed. The Touring Club of America has been agitating the matter.

MILWAUKEE.—The Milwaukee Automobile Club on Saturday evening, September 30, held the largest stag party since its new clubhouse on the Blue Mound road, at Cottrell avenue, was opened. More than 500 members and their friends participated. The stag was the second of a series to be held during the fall and winter to stimulate interest in the club among motorists who are not yet members, and which is

part of the general campaign to make the membership 1,000 before January 1.

OKLAHOMA—The 800-mile route of the Oklahoma reliability run for 1911, which begins October 12, passes through some sections of the State where automobiles are seldom seen, and J. L. McClelland, pilot, who donated the services of his "Hudson 33" as the pathfinding car, states that all along the route the party was besieged by prospective purchasers. In order to give the entrants a chance to meet the prospects, the route book has been made up for short runs, putting the contestants into controls each day in time to talk business.

MISHAWAKA, IND.—The Fostoria Aluminum Manufacturing Company has changed its name to the American Casting Company. The company recently moved to Mishawaka from Fostoria, Ohio, and manufactures automobile castings. The company's plant will be re-equipped with considerable new machinery. At a meeting of the directors held recently the following officers were elected: W. H. Rockoff, president and treasurer; W. H. Gilbert, vice-president, and B. E. Rockoff, secretary. The company expects to operate its plant on a larger scale and is widening its scope of operations.

BOSTON—The annual reunion of the Velie branch house managers, agents, heads of the service stations and salesmen throughout the country, will be held at the Velie factory in Moline, Ill., October 9-15. The new Velie 1912 models will be shown for the first time and questions of interest in the automobile industry will be taken up by the various Velie representatives. The N. E. Velie branch will be represented by Walter B. Johnson, Essex Junction, Vt.; George H. Snell, of Attleboro, Mass.; Arthur Beharrell, of Lowell, Mass., and Harold D. Bornstein, of the Velie Boston branch.

**CLEVELAND**—The next annual meeting of the Gas and Gasoline Engine Trades Association will be held in Cleveland December 5-8.

**DETROIT**—The Herreshoff Motor Company is preparing to move into its new quarters on Woodward avenue, between Belmont and Trowbridge avenues.

**OMAHA**—The Kirkland-Hicken Company has been formed to handle fireproof portable garages and pumping machinery in Nebraska, Iowa, South Dakota and Colorado.

**SYRACUSE, N. Y.**—W. H. Emond, chief designer of the Franklin company, has left for Europe where he will study foreign designs. He will visit France, Germany and England.

**WORCESTER, MASS.**—The Stearns-Knight car agency has been taken over by the Worcester Motor Car Company which, with the Franklin, now has an excellent display of 1912 models.

**DETROIT**—The Ford Motor Company has announced that the company would build 75,000 cars for 1912. Besides the model T fitted with various body styles, the company will put out a new light delivery wagon.

**HENDERSON, N. C.**—The Corbitt Automobile Company, recently incorporated for \$250,000, will take over the automobile department of the Corbitt Buggy Company. The company announces that the 1912 production will be about 500.

**GRAND RAPIDS, WIS.**—The Commercial Club, of Grand Rapids, Wis., practically has obtained sufficient subscriptions for stock in the proposed Crowe Motor Car Company, to make certain the establishment of the plant in this city.

**WORCESTER, MASS.**—The Atterbury Motor Truck Company, of Buffalo, has opened a branch in this city, at 735 Main street, where repairs will be made and where a large salesroom is now being fitted for a display of many models for commercial use.

**MINNEAPOLIS, MINN.**—Walter D. Rightmire, for several years associated with the automobile trade in Minneapolis, has open-

ed a branch at Duluth, where he has secured the Iron Range as a territory for the Packard line. He has installed a service department.

**INDIANAPOLIS, IND.**—Dr. H. L. Lathrop has resigned as treasurer of the Henderson Motor Sales Company, Indianapolis, and has been succeeded by his son, H. C. Lathrop. O. W. Seymour and E. E. Kleinmeyer have just been added to the local sales department in Indianapolis.

**DENVER**—The Lozier Six, which was designated by the Denver Motor Club as the pathfinder for the Denver Times Reliability Contest, which the club will supervise October 9-14, returned to the city on Thursday, having completed its work of routing the tour. The route selected is 867 miles long.

**NEW YORK**—R. J. Laciari has been appointed general manager of the New York branch of the Hupp Corporation which has just leased the building at 1989 Broadway, formerly occupied by the Carhartt Sales

Company. The entire building will be devoted to the display of the "R. C. H." automobiles and of the Hupp-Yeats electric cars.

**WORCESTER, MASS.**—Local business men with the cooperation of the Worcester Board of Trade are making determined efforts to have the United States Motor Company locate its proposed special factory, to manufacture parts of automobiles, in this city and to that end several excellent factory sites have been offered the concern.

**MINNEAPOLIS, MINN.**—Minneapolis is afforded an opportunity to secure a large automobile-parts manufacturing plant provided sufficient inducements are offered the United States Motor Company. B. E. Stimson, manager of the United States Motor Company, says that the concern is planning a large factory to be located in the Middle West at once and he suggests that this city make an effort to have it placed here.



## Automobile Incorporations

### AUTOMOBILES AND PARTS

**ALBANY, N. Y.**—Tri City Motor Company; to deal in automobiles.

**ALEXANDRIA, VA.**—The B. F. Board Motor Truck Co.; capital, \$100,000.

**CHARLESTOWN, S. C.**—The Robinson Automobile Co.; capital, \$10,000. Incorporators: J. T. Robinson and B. F. Robinson.

**COLUMBIA, S. C.**—The Gregory-Conder Motor Co.; capital, \$20,000.

**DALLAS, TEXAS.**—Overland Automobile Co.; capital, \$25,000; to handle automobiles. Incorporators: W. W. Taxis, D. T. Finley and F. M. Bannell.

**EL PASO, TEXAS.**—Rio Grande Automobile Co.; capital, \$5,000. Incorporators: Max Moye, W. F. Carter, Jr., and John M. Wyatt.

**LAFAYETTE, IND.**—Ross Machine Co.; capital, \$15,000; to manufacture automobile parts. Incorporators: David E. Williams, C. Linn and Edward A. Ross.

**NEWARK, N. J.**—Blair Manufacturing Co.; capital, \$300,000; to build automobiles. Incorporators: Frank M. Blair, John R. McCune, Willis A. Robbins, Edwin C. Wright and Harry H. Baird.

### AUTOMOBILE GARAGES AND ACCESSORIES, ETC.

**CAMDEN, N. J.**—American Roller Bearing Co.; capital, \$500,000; to manufacture roller bearings. Incorporators: V. A. Murray, L. A. Myers and D. Bellinger.

**COLUMBUS, OHIO.**—Borland Manufacturing Co.; capital, \$150,000; to manufacture automobile wheels, automatic pipe wrenches and other tools. Incorporators: J. Arceher Borland, G. W. Borland, G. A. Hoffelder, E. W. Habermass, H. L. Hogan and Otto Klein.

**MEMPHIS, TENN.**—The Osburn Automobile Supply Co.; capital, \$15,000. Incorporators: N. F. Osburn, W. J. Sbay and W. P. Armstrong.

**NEW YORK, N. Y.**—Higrade Auto Tire Sales Co.; capital, \$50,000; to manufacture and deal in tires. Incorporators: A. Fosbay, H. Neubardt and R. Goldman.

**NEW YORK, N. Y.**—Senora Motor Horn Co.; capital, \$50,000; to manufacture automobile signals and supplies. Incorporators: Russel Goldman, A. Fosbay and Helen Neubardt.

**NEW YORK, N. Y.**—The Griffins Automobile Supply Co.; capital, \$100,000; to handle automobile supplies, etc. Incorporators: Carl S. Brown, Frederick Kopper, Jr., and Thomas H. Griffins.

**PADUCAH, KY.**—Kentucky Auto & Machine Co.; capital, \$5,000; to deal in automobile supplies. Incorporators: F. M. Fisher, R. G. Fisher and W. F. Paxton.

**SHAWANO, WIS.**—Frogner Auto Co.; capital, \$5,000; to handle a garage.

**SPRINGFIELD, ILL.**—Reliable Tire Repair Co.; capital, \$2,400; tire repairing. Incorporators: John V. Leslie, George Haas and Bert A. Fritz.

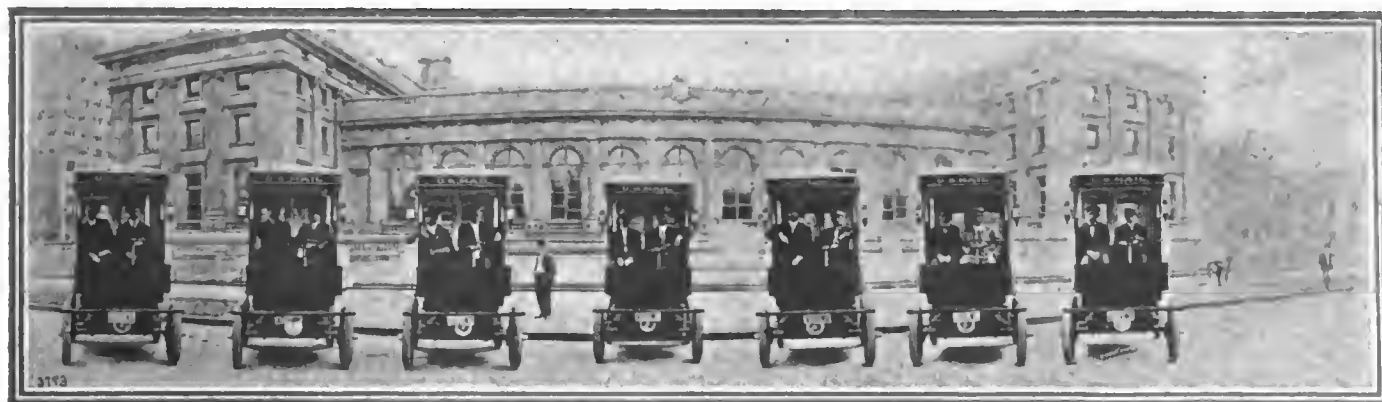

Battery of seven United States mail wagons delivered by the Waverley Company for use in the Post Office service in St. Louis

# OF INTEREST *to the* INDUSTRY

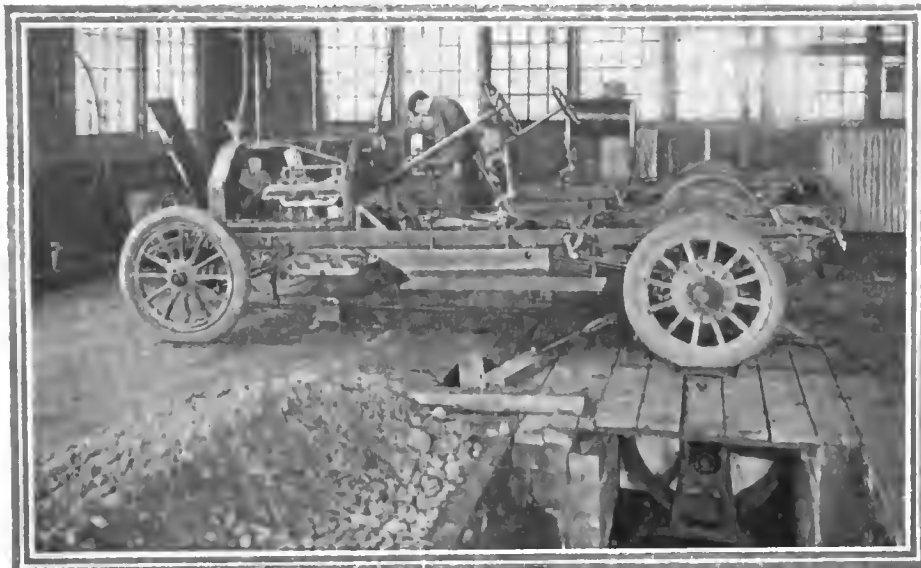

**D**AYTON, O.—In the testing department of the Speedwell factory the bearings were formerly run in by raising the rear wheels on a revolving drum. The motor is started and the gears engaged so that the rear wheels revolve on the drum—a brake on the latter providing friction equivalent to that of the road surface. An improvement has recently been effected by lifting the rear axle so that the wheels stand clear of the floor. Then the live split rear axles are drawn out, and axles with sprockets substituted. Coupling the sprockets by chain drive to a shaft provided with sprockets and brake, the same result is accomplished without tire wear. This method of testing suggests that a farmer, by the use of a similar contrivance could use his motor car to furnish power for pumping and running various farm machinery when the car is not in use on the road.

**DETROIT**—The T. Eaton Company recently completed negotiations with the Lozier Motor Company for the sales rights of the Lozier in Ontario.

**OIL CITY, PA.**—E. M. Bowen and G. C. McClelland have opened the West End Garage at Oil City in the fireproof building Front and Moran streets.

**SYRACUSE, N. Y.**—W. E. Hookway has taken over the agency for Atterbury trucks, 1,500-pound delivery wagons and 1-ton trucks, along with the Reliance line of heavy trucks.

**SYRACUSE, N. Y.**—J. E. Bristol, of the United Motor Syracuse Company, who has just finished a successful tour of Northern New York in the interest of the Maxwell runabout, reports that he now has also the agency for the Samson motor truck.

**SYRACUSE, N. Y.**—E. F. Chaskel, formerly in the automobile business in New York, has established himself with the National Motor Sales Company, of this city, and will exploit National cars in this section.

**SEATTLE**—Hugh A. Baird, manager of the Franklin Automobile Company, of this city, has organized a selling agency which is known as Hugh A. Baird & Co. In addition to handling the Franklin product, he will act as agent for Reo touring cars, runabouts and trucks, and the Apperson line.

**BUFFALO, N. Y.**—The Lippard-Steward Motor Car Company, of Buffalo, has just secured the large and well-located plant formerly occupied by the Thomas Taxi-Cab Company, moving into the new quarters October 1. The company will manufacture 1,500-pound capacity delivery motor trucks, police patrols, ambulances, chemical fire wagons, etc.

**NEW YORK CITY**—E. Louis Kuhns, long manager of the motor car department of the Chicago Studebaker branch, has been transferred to eastern territory and last Monday he assumed the management of the New York Studebaker branch. Temporarily Lafayette Markle, special factory representative, is in charge of the Chicago branch, while H. E. Westerdale is looking after the retail business.

**SAN FRANCISCO**—The largest and most elaborate automobile building in San Francisco has just been occupied by the H. O. Harrison Company, distributors of Peerless and Everitt cars in California. The building is said to be one of the largest in the United States devoted exclusively to automobile purposes. The building is four stories on the east end and three stories on the principal frontage on Van Ness avenue.

**SAN FRANCISCO, Sept. 26**—The Speedwell Motor Car Company, of California, has moved to new and larger quarters at 422-428 Van Ness avenue. This move affords a larger showroom, and there is a good-sized workshop in the rear. L. V. Lynch, president and manager of the company, came here from the East two years ago, and is now recognized as one of the most aggressive men in the California field.

**SAN FRANCISCO**—Bert S. Bingham, Pacific Coast representative of the Regal Motor Car Company, of Detroit, has been appointed manager of the eastern district of that company, with headquarters in New York City. He will be in charge of the warehouses in that territory. He has already left for his new field. Bingham established the Regal branch in San Francisco two years ago, and since the abolition of the branch in favor of a private agent, he has been general coast representative of the company.

**SAN FRANCISCO**—The Standard Motor Car Company, the newly appointed coast distributors of Division B of the United States Motor Company, comprising the Stoddard-Dayton and the Courier lines, is preparing to make a considerable enlargement of its quarters at the corner of Golden Gate and Van Ness avenues, which marks the center of the automobile retailing district of the city. The Standard has a lease of the entire building, and it is probable that some of the other firms will be obliged to find new quarters so that the Standard may expand.

**SYRACUSE, N. Y.**—The R. N. Tannahill Company, of Greenville, S. C., has signed up the Franklin dealership for that locality, succeeding C. M. Wing. J. W. Vernam, of New Kensington, Pa., has contracted with the Franklin Automobile Company as a sub-dealer in the Pittsburg district. Charles Wirth, of Terre Haute, Ind., has been made salesman by the Terre Haute Automobile Company, the Franklin dealer in that town. The Franklin Automobile Company is to be represented the coming season in the southern half of Texas by the Franklin Motor Car Company, of Houston.

**SAN FRANCISCO**—The Apperson car is now represented in San Francisco and throughout Northern California by the Weeks-Covell Automobile Company, who will also handle the Pathfinder and Parry cars in this territory. W. H. Weeks, a San Francisco architect, is president of the newly organized company, with J. H. Covell, a successful garage man of Watsonville, as vice-president and manager. Russell Cuthbert has been appointed sales manager. Temporary quarters have been secured at 550 Golden Gate avenue.



# PATENTS GONE TO ISSUE

**FRICTION CLUTCH**—Being of the multiple-cone type.

The clutch covered by this patent and shown in Fig. 1 comprises a number of driving and driven members with opposing surfaces, frictionally engaging segments being interposed between the surfaces and arranged one in advance of the other in a ring-shaped series substantially concentric with the surfaces mentioned. A portion of each segment is fixed to one surface, and springs are provided between each segment and the surface it is connected to, which springs normally hold surface and segment out of frictional engagement. Means are also provided whereby the members may be moved axially toward one another to bring about engagement of the frictioning members.

No. 1,004,047—to Willard C. Lipe, Syracuse, N. Y. Granted September 26, 1911; filed December 7, 1905.

**WHISTLE**—Being of the type driven by an electric motor.

1. The whistle this patent relates to consists of a waterproof casing with an opening therein, an air pump mounted in the opening, an outwardly projecting whistle forming the pump outlet. Within the casing a rotary motor is mounted which is connected to the pump by gearing.

No. 1,004,337—to George F. Atwood, New York City, assignor to Western Electric Co., Chicago, Ill. Granted September 26, 1911; filed October 25, 1907.

**GEARSHIFT LOCK**—A plate for locking change-speed lever in neutral position.

The lock (Fig. 2) comprises an H-plate, a lever adjustably guided by the plate, which includes means for holding the lever in neutral position, a member being removably fitted to the H-plate and embracing a portion of the lever and operating to hold the lever against movement on the

H-plate. The member mentioned has spaced walls with a recess therein and the opposite wall has a bolt-receiving passage. A second member is removably fitted to the first member and provided with a lug removably fitting the recess in the first member, and it also carries a bolt adapted for locking engagement in the aforesaid passage to hold the first and second member connected with each other.

No. 1,004,396—to David H. Evans, Detroit, Mich. Granted September 26, 1911; filed March 7, 1911.

**ENGINE STARTER**—Consisting of a ratchet and pawl.

The starter this patent refers to (Fig. 3) consists of a combination with a ratchet wheel having a hub fixed to the end of the engine shaft, of a drum surrounding that wheel and loosely embracing its hub and having a hole in line with the shaft mentioned. A wide pawl is pivoted within the drum and normally pressed into engagement with the ratchet by a spring. Means are provided to direct the rotation of the drum in one direction, as well as retracting means for rotating it in the opposite direction. A bracket is secured to the automobile frame, projects fixedly and axially through the hole in the drum, and a finger rises rigidly from the bracket within the drum between the latter and the wheel. The tip of this finger constitutes a cam upon which the pawl rides as the drum returns to its retracted position.

No. 1,004,508—to Ernest N. Ward, Baxter Springs, Kan., assignor of one-half to Jay F. Ripley, Joplin, Mo. Granted September 26, 1911; filed January 5, 1911.

**SPARK PLUG**—Being of the make-and-break type for low-tension ignition systems.

1. The plug (Fig. 4) has among its elements an electromagnetic coil having a core which is provided with a semi-cylindrical recess with a flat face. From this

face a series of studs project, being arranged longitudinally and eccentrically of the core. In the recess mentioned fits loosely a semi-cylindrical armature having an inner face which is provided with a series of recesses, loosely receding studs, whereby the armature may be rocked to and from the core. A movable contact carried by the armature is connected therewith, and a stationary contact is provided which is contacted by the movable contact when the armature is in the outward position, means being provided to hold the armature in that position.

No. 1,004,325—to Max Wild, Stuttgart, Germany. Granted September 26, 1911; filed November 6, 1908.

**PNEUMATIC TIRE**—Consisting of a special cover and lining.

1. In combination with a wheel rim and a tire cover held thereto, an air tube within said cover, a lining between said cover and the air tube, having an inextensible crown which is recessed in proximity to the tread and adapted to holding the outer cover distended and to take up the vibrations of the running jars while being guarded by said crown against excessive air pressure from the air tube substantially as set forth.

No. 1,004,343—to John Charles Barker, Leeds, England. Granted September 26, 1911; filed May 7, 1910.

**COMBINED VALVE AND TRAP**—Consisting of a valve with a partition which forms a baffle plate to trap moisture.

A valve casing having an inlet and an outlet, a partition in said casing, a trap extending downward from said casing, one side of trap communicating with said inlet and the other side thereof communicating with the outlet.

No. 1,004,239—to Wm. Brunton, Elwyn, Pa. Granted September 26, 1911; filed October 22, 1911.

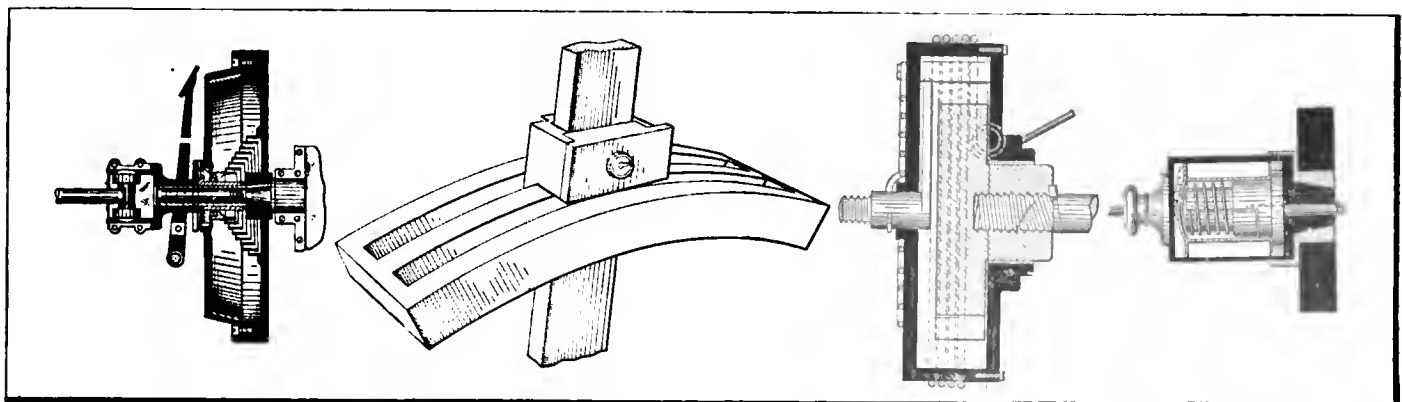

Fig. 1—Lipe Clutch

Fig. 2—Evans Gearshift Lock

Fig. 3—Ward Engine Starter

Fig. 4—Wild Spark Plug



# Newest Ideas Among the Accessories

## Prest-O-Tire Tube

THE Prest-O-Tire tube shown in Figs. 3, 4 and 5 has been constructed with the object of pumping up a tire in the minimum space of time and with the least effort. Fig. 4 shows the external view of the tube in its application to a tire. The tube is made of a piece of steel 1 foot long, and at its upper end is closed by a copper

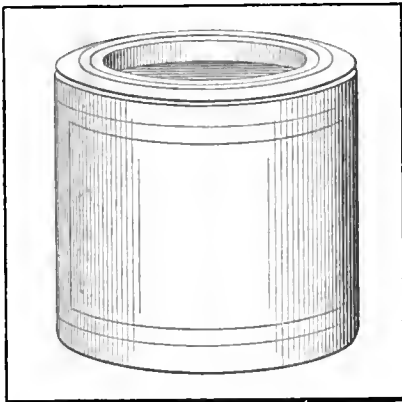

Fig. 1—Goodyear quick repair gum

plate fully strong enough to withstand the 900 pounds pressure of the carbonic acid gas enclosed in the tube. Fig. 3 shows the handle  $H_1$  screwed off the tank; it contains a passageway for the gas and a needle  $N_1$ , which when screwed down cuts a hole in the copper plate shown at  $C_1$  Fig. 5). The punctured plate is seen at  $P_1$ . If the needle valve is opened by turning the handle, the gas is allowed to escape through the passageway which is connected up to a flexible tube  $F_1$  and this in turn to the tire valve. When the tire is inflated to the desired degree the handle is turned so as to close the valve and shut off the gas.

The section of the working parts is seen

in Fig. 5, and the component parts are also shown. The seating  $S_1$  of the needle valve is bored through the copper plate  $C_1$  and so arranged that lifting the needle makes a free way for the carbon dioxide. The valve casing  $C_2$  is bored to permit of a passage for the gas which rises around the needle  $N_1$  and escapes through  $O_1$ . The needle is fastened to the body of the valve spindle  $S_1$ , which is threaded at  $P_2$  to engage with the threaded inside of the casing. The upper part of the spindle is supported by a bushing  $B_1$  and the handle  $H_1$  serves to operate the needle.

At a test made with the tube a 36 x 3 1-2 tire was inflated from 0 to 90 pounds within 1 minute and 32 seconds. The tube is the product of the Prest-O-Lite Company, Indianapolis, Ind. First cost of the tank is low and after the contents have been used for inflating purposes, it is exchanged for a full tank for a very small sum.

## Goodyear Repair Gum

The Goodyear Quick Repair Gum comes in tins, as shown in Fig. 1, and its purpose is the repair of cuts in outer tire casings as well as in inner tubes. In either case the simple process of repairing the damage consists of two steps. After washing the wound with gasoline it is coated with Goodyear patching cement, two coats being necessary to prepare the tube or casing for the subsequent treatment with the repair gum. After the second cement coat has dried, a sufficiently large piece of the repair gum is kneaded with the fingers until it becomes very soft; then it is applied to the wound, taking care that the latter is filled completely and that the gum adheres to the cement at all portions of the wound. This repair gum is manufactured by the Goodyear Tire & Rubber Co., Akron, Ohio.

## Doyle Signal Light

In Fig. 2 is shown a combination of a tail lamp, license number and direction signal, the accessory illustrated being Doyle's warning signal light. It is a small metal box containing four incandescent lamps which may be lighted singly or in unison from a little switchboard attached to the steering wheel. The lights are placed be-

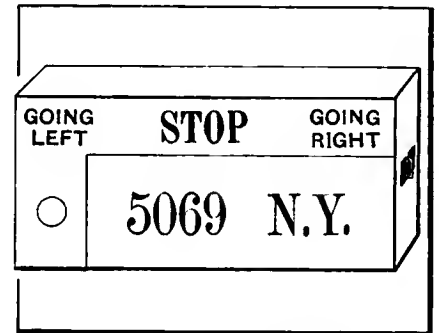

Fig. 2—Doyle's warning signal light

hind perforations reading as in Fig. 2, and by turning on any of the upper three lights, the chauffeur may inform the driver of the car behind of his intention of turning into the next street to the right or left, as the case may be, or of stopping, advising his follower to slow down. The usual manner of giving these signals is by a motion of the arm, which is hardly visible at night, so that some method of illumination is necessary. The lower part of the signal box contains a pocket for a number plate, which may be removed therefrom at will, and a red jewel throwing enough light on the number to make it legible. The lamps in the top row, being used only occasionally, require very little current. The selling office of the maker is at 1777 Broadway, New York City.



Fig. 3—Prest-O-Tire tube and fittings

Fig. 4—Application of tube to tire

Fig. 5—Section through working parts

# THE AUTOMOBILE

## Bergdoll in Benz, Fairmount Winner



Erwin Bergdoll, Driver of the Big Benz Car Which Won the Fairmount Park Race and Established New Lap and Race Records

The Winning Bergdoll-Benz Combination Being Given the Checkered Flag by Starter Gantert



**P**HILADELPHIA, PA., Oct. 9.—Leading practically all the way, Benz No. 8, driven by the boyish millionaire, Erwin Bergdoll, won the sweepstakes and the class 6C prize over the Fairmount Park course today. The Benz broke the record for the classic; raised the level of average speed to 61.25 miles an hour; lowered the lap mark to 7:28 and cleaned up all around.

Mercedes, No. 17, driven by Spencer Wishart, the same car that raced into a forward position in the 500-mile sweepstakes at Indianapolis on Decoration Day, finished second in the general race and first in its class, flashing past the finish line 1:41 ahead of Lozier No. 3, Ralph Mulford's mount. The Mercedes was protested immediately after the finish for failing to carry its crew throughout and the protest was allowed.

National 16, Disbrow, won the Class 4C division from the consistent-running Stutz, piloted by Anderson.

In Class 3C, the only car to complete the full course was Mercer No. 11, Hughes, which made the distance in 209:45.30. When the race was called off, the Ohio pair were still jogging around, No. 12 having completed twenty laps and No. 19 having finished twenty-two rounds of the 8 1/10 mile course.

The course was not in the best condition, having dried

### The Winners

#### DIVISION 6C.

No. 8. Benz.  
Bergdoll driver.  
Time, 3:18:41.25.

#### DIVISION 5C.

No. 17. Mercedes.  
Wishart driver.  
Time, 3:20:11.42.

#### DIVISION 4C.

No. 16. National.  
Disbrow driver.  
Time, 3:28:22.32.

#### DIVISION 3C.

No. 11. Mercer.  
Hughes driver.  
Time, 3:29:45.30.



National No. 2, driven by Zengel, who won last year's race in a Chadwick

Disbrow National, No. 16, winner in its class

out on top to such an extent that the racing cars threw up dense dust clouds in making the turns. The fast time accomplished was due to the improvement in the automobiles themselves rather than to course conditions.

The crowd was rather slow in assembling, but just before noon the seat-holders in the grandstands poured in and when Starter G. Hilton Gantert lined up the contestants, there was scarcely a vacant seat. All around the course the crowds assembled to witness the speed struggle and while the total num-

ber of those who witnessed the race was much below that of last year, it is estimated that at least 350,000 saw the triumph of the Philadelphia-owned car.

The cars were arranged in two lines, the even numbers on the pole and the odds on the rail and the heads of the columns were sent away at 20-second intervals. F. E. Edwards, chairman of the Technical Committee of the Contest Board, stood at Starter Gantert's elbow throughout this important function. The start was very perfect.

FOURTH ANNUAL 200-MILE FAIRMOUNT PARK

Division 6-C—For Cars Whose Piston Displacement

No.	CAR	Piston Displacement	DRIVER	1	2	3	4	5	6	7	8	9	10
8	BENZ.....	730	Erwin Bergdoll.....	7.34	15.02	22.41	30.28	38.19	46.02	53.30	61.06	68.48	76.47
15	FIAT.....	615	J. Fred Betz, 3d.....	7.52	15.41	22.41	30.28	38.19	46.02	53.30	61.06	68.48	76.47
					7.28	7.39	7.39	7.51	7.43	7.28	7.36	7.42	7.59
					7.49	Out— broken connecting rod							

Division 5-C—For Cars Whose Piston Displacement

2	NATIONAL.....	589	Len Zengel.....	7.51	15.40	27.43	35.38	43.34	51.27	59.15	67.03	74.55	82.59
3	LOZIER.....	544	Ralph Mulford.....	7.55	15.47	23.40	31.34	39.30	47.32	55.23	63.13	70.57	78.48
9	LOZIER.....	544	Harry Grant.....	8.17	16.25	24.34	32.41	40.51	48.58	57.02	65.04	73.08	81.13
17	MERCEDES.....	583	S. Wishart.....	7.52	15.40	23.30	31.26	39.19	47.12	55.06	63.02	70.57	79.37
18	MERCEDES.....	560	W. Wallace.....	8.27	16.41	24.59	33.19	41.31	49.44	57.57	66.07	74.20	84.04
					8.14	8.18	8.20	8.12	8.13	8.13	8.10	8.13	9.44

Division 4-C—For Cars Whose Piston Displacement

6	NATIONAL.....	447	Donald Herr.....	8.38	17.09	25.33	34.04	43.25	51.03	59.16	67.30	75.42	84.00
10	STUTZ.....	389.9	Gil. Anderson.....	9.09	17.55	26.36	35.24	44.18	53.22	62.18	71.07	80.21	89.20
16	NATIONAL.....	447	Louis Disbrow.....	8.30	16.46	24.58	33.12	41.24	49.32	57.38	65.42	73.57	82.07
					8.16	8.12	8.14	8.12	8.08	8.06	8.04	8.15	8.10

Division 3-C—For Cars Whose Piston Displacement

4	COLE.....	286	Chas. Basle.....	9.24	18.58	28.22	37.42	47.39	57.45	Out—carbureter trouble			
5	MERCER.....	300.6	Ralph De Palma.....	8.20	16.49	25.05	33.22	41.38	49.55	58.11	66.24	74.31	82.37
7	CASE.....	300.7	J. Jagersberger.....	8.41	17.22	26.03	34.47	43.21	51.52	60.24	68.51	79.02	87.26
11	MERCER.....	300.6	Hughie Hughes.....	8.21	16.27	24.51	33.06	41.15	49.23	57.36	65.51	74.05	82.24
12	OHIO.....	299	George Parker.....	9.29	18.46	27.47	36.49	45.44	54.35	63.33	72.33	81.33	90.34
19	OHIO.....	299	H. S. Matthews.....	9.58	19.54	29.49	39.39	49.23	59.04	68.47	79.00	88.57	98.44
					9.56	9.55	9.50	9.44	9.41	9.43	10.13	9.57	9.47



Mulford's Lozier, finishing second in its class



Wishart's Mercedes, which was disqualified for losing its mechanician

National No. 2, Zengel, was first away, followed by Lozier No. 3, Mulford; then came the Cole No. 4, Basle, and Mercer No. 5, De Palma, and so on to the end of the line, which was occupied by Ohio No. 19, Matthews.

National No. 2 was the first to appear at the head of the stretch on the initial round and came down to the wire wide open in 7:51, widening the distance between it and the pursuing Lozier by 4 seconds on this circuit.

But neither of these cars was destined to enjoy a leading

position for the round, or in fact at any time during the race, as the giant Benz No. 8 came down to the line in 7:34, lowering the lap record for the course by 4 seconds, even though the standing start would seem to have interposed an insurmountable obstacle to record breaking. That first swift round foreshadowed the ultimate result of the race, for it was a foregone conclusion after the time was posted that, barring accidents, there was nothing that could catch the flying leader.

During the preliminary practice the speed of this car was

ROAD RACE--TIME BY LAPS--OCTOBER 9, 1911

Ranges From 601 to 750 Cubic Inches

11	12	13	14	15	16	17	18	19	20	21	22	23	24	25
84.33	92.31	100.08	109.13	116.43	124.25	134.48	142.20	149.53	157.06	165.06	172.37	182.07	191.03	198.41.35
7.46	7.58	7.37	9.05	7.30	7.42	10.23	7.42	7.33	7.35	7.48	7.31	9.30	8.56	7.38

Ranges From 451 to 600 Cubic Inches

90.55	98.44	106.33	114.18	122.02	129.47	137.35	147.46	155.46	167.01	174.53	182.47	190.30	198.14	205.59.36
7.56	7.49	7.49	7.45	7.44	7.45	7.48	10.11	8.00	11.15	7.52	7.54	7.43	7.44	7.45
86.36	94.19	102.00	109.50	118.34	126.26	135.19	143.03	150.47	158.31	166.15	175.50	186.37	194.18	201.52.78
7.48	7.43	7.41	7.50	8.44	7.52	8.53	7.44	7.44	7.44	7.44	9.35	10.47	7.41	7.34
89.43	97.18	105.24	115.32	125.55	133.59	142.05	150.20	158.20	166.28	175.42	183.54	192.08	200.16	208.50.37
8.30	7.35	8.06	10.08	10.23	8.04	8.06	8.15	8.20	8.08	9.14	8.12	8.14	8.08	8.34
87.29	95.14	103.02	110.50	118.40	126.28	134.18	142.01	149.51	157.41	165.46	177.00	184.47	192.30	200.11.42
7.52	7.45	7.48	7.48	7.50	7.48	7.50	7.43	7.50	7.50	8.05	11.14	7.47	7.43	7.41
92.29	108.32	117.49	127.01	145.01	154.08	169.05	179.12	188.41	197.19	208.29	217.46			
8.25	16.03	9.17	9.12	18.00	9.07	14.57	10.07	9.29	8.38	11.10	9.17			

Ranges From 301 to 450 Cubic Inches

94.49	103.29	111.46	120.01	128.14	136.30	144.48	153.10	161.30	169.47	178.01	186.23	195.12	211.57	220.33.87
8.08	8.40	8.17	8.15	8.13	8.16	8.18	8.22	8.20	8.17	8.14	8.22	8.49	16.45	8.36
98.02	106.40	115.22	124.03	132.48	141.42	150.30	159.14	168.09	176.00	185.36	194.21	203.03	211.45	220.23.05
8.42	8.38	8.42	8.41	8.45	8.54	8.48	8.44	8.55	7.51	9.36	8.45	8.42	8.42	8.38
90.15	98.16	106.24	114.30	122.35	131.12	141.00	149.18	158.57	167.09	175.22	183.37	191.52	199.59	208.22.32
8.08	8.01	8.08	8.06	8.05	8.37	9.48	8.18	9.39	8.12	8.13	8.15	8.15	8.07	8.23

Ranges From 231 to 300 Cubic Inches

90.45	98.54	107.17	115.40	125.42	148.16	156.43	165.06	173.28	182.05	191.36	201.38			
8.08	8.09	8.23	8.23	10.02	22.34	8.27	8.23	8.22	8.37	9.31	10.02			
96.04	104.30	113.02	120.40	133.34										
8.38	8.26	8.32	8.38	11.54										
90.39	98.53	107.03	115.10	123.14	131.29	139.50	150.24	158.35	166.49	175.24	183.56	192.35	201.14	209.45.30
8.15	8.14	8.10	8.07	8.04	8.15	8.21	10.34	8.11	8.14	8.35	8.32	8.39	8.39	8.31
114.57	123.57	133.02	142.15	151.27	160.43	187.17	196.23	205.27	214.34					
11.23	9.00	9.05	9.13	9.12	9.16	26.34	9.06	9.04	9.07					
108.24	118.13	127.50	137.35	147.22	157.03	166.44	176.22	186.09	195.49	205.36	215.21			
9.40	9.49	9.37	9.45	9.47	9.41	9.41	9.38	9.47	9.40	9.47	9.45			

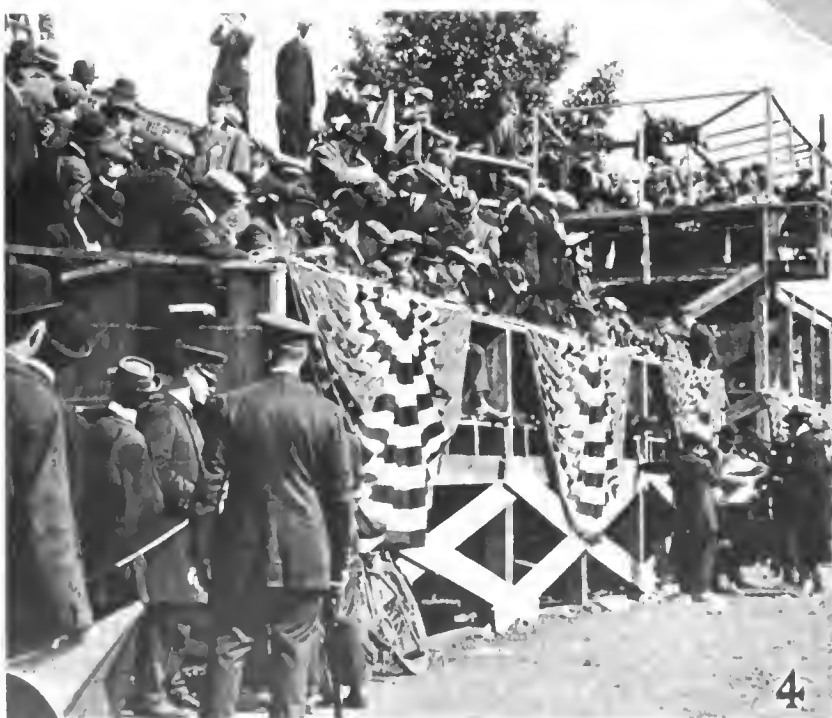

#### SCENES AT THE FAIRMOUNT PARK RACE

1. Despite the postponement of the race from the previous Saturday, the stands and course were crowded. The illustration shows the excellent manner in which the course was guarded.

2. Ohio car, No. 12, driven by George Parker, which was still running at the conclusion of the race.

3. The Lozier-Mulford combination was a favorite with the crowds—the car is shown passing the grandstand at 70 miles an hour.

4. The accommodations for the 200 pressmen were thorough in every detail, and reflected great credit on the management.





SCENES AT THE FAIRMOUNT PARK RACE

1. In lining up the cars at the start the machines were arranged in two lines, even numbers on the pole, odd numbers on the rail.

2. The winning Benz, with Bergdoll at the wheel, was caught at close quarters by The Automobile staff photographer while the outfit was travelling close to 75 miles an hour.

3. The Stutz entry, No. 10, with Gil Anderson at the wheel, performed creditably throughout the race.

4. The thousands of cars were parked well back from the course, with a strong cordon of police between them and the road.



The Hughes Mercer, which ran consistently and captured 3C honors

specially noted by the contesting drivers and their attitude is best expressed by the sentiment spoken by Mulford before the race in conversing with Zengel:

"Have you passed that big Benz?" inquired Zengel, speaking of the preliminary practice.

"No," replied Mulford, "I haven't passed him, but I have seen him go by."

"Who was that driving the car last Thursday?" asked Zengel.

"Durned if I know," came the answer, "he drove like Hemery."

And that is the whole story.

From the moment Benz No. 8 showed in front at the end of the first lap, with an advantage of 17 seconds over the second car, it was a battle merely for position in the classes. But they made a gallant fight and kept shooting at the big car from one end of the race to the other.

Nobody experienced any trouble in the first round, Ohio No. 19 finishing the lap in last place in 9:58 with the other contestants spread out at intervals between that time and the fast performance of the leader.

National No. 2 led for the round in Class 5C; National No. 16 was the pacemaker for Class 4C in 8:30, while Mercer No. 5 was first around in Class 3C in 8:20.

The second round was another record breaker, the Benz negotiating the distance in 7:28, a new course mark, with Mercedes No. 17 and National No. 2 tied for second honors. National No. 16 still led its class, but in 3C Mercer No. 11 displaced its teammate and showed in front at the tape. There were no mishaps in this round, everybody finishing without untoward incident.

For the following fourteen laps the Benz stayed out in front, moderating its extreme speed in order to save tires. Mercedes No. 17 was second for the next half-dozen rounds, maintaining its position about 2 minutes behind Bergdoll's mount, with Lozier No. 3 in third place, a few seconds back.

In round ten, however, the Lozier went ahead of the Mercedes and began a long stern chase after the leader. For the next six laps the Lozier stayed in second place without cutting down the gap materially.

In the seventeenth round both the Benz and the Lozier stopped for tire changes and the Mercedes, which was only a few seconds behind the white car, moved up into pacemaker's position.

Bergdoll did not essay to wrest the lead away from the Mercedes in one round, but he kept cutting down the seconds for three laps and at the end of the twentieth lap the black car was again setting the pace.

Mercedes experienced trouble in round twenty-two and the Lozier stepped up into second place again, only to succumb to a pair of blown tires in the following lap.

The final round and the finish were not spectacular. Everybody knew that the Benz would win unless it broke an axle and it fulfilled its owner's expectations by making the last lap in 7:38.35, winning rather easily, although by only a moderate margin, in 198:41.35. This is faster than the record-breaking performance of Chadwick last year by more than 10 minutes, which would represent  $1\frac{1}{4}$  laps run in reasonably fast racing time.

The Mercedes finished second in 200:11.42, which is in excess of a mile-a-minute gait, but was disqualified for an unusual occurrence during mid-race. Wishart was going fast down the Sweetbriar incline and when he turned into the straightaway, just before passing Penn mansion, Bob Willoughby, his mechanic, was unseated by the swerve of the car and fell out upon the roadway. Willoughby rolled out of the course of the racing cars and Wishart, not to be delayed for a second at that important stage of the race, went on without him. He picked up another helper at the pits and finished the race as has been told. Willoughby was not seriously hurt.

Under the rules a contesting car in such a race as the Fairmount Park must carry a driver and mechanic from start to finish and when formal protest was lodged with Referee Dunlap, on behalf of the Lozier company, the official promptly allowed the protest, disqualified the Mercedes and gave the place to Lozier No. 3.

The matter in all probability will be presented to the Contest Board for revision.



De Palma's Mercer passing the grandstand at a 65-mile clip



De Palma's Mercer drawing up at the pits with a broken steering knuckle—Wallace's Mercedes just passing

Wishart Mercedes overhauling the Grant Lozier at the Belmont Avenue turn



Mercedes driven by Hughes, which was the only car in its class to finish the race—the Mercedes has just passed the Cole



Looking down the stretch toward the first turn at The top of Sweetbrier Hill

There was virtually no contest in division 6C. Originally three entries were made for this class, including two Fiats of 90-horsepower and the Benz rated at the same power. Fiat No. 1 was scratched after disapproval had been expressed as to the good taste of starting Lee Oldfield as its driver. This left the Bergdoll Benz and the Betz Fiat to fight it out in the big class. The Fiat made two fast rounds, being only 39 seconds behind its rival at the end of the second circuit. But during the third lap a broken connecting rod caused it to limp up to the grandstand and withdraw. Mr. Betz has experienced similar misfortune. Last year his mount broke a crankshaft while well up with the leaders and he was obliged to watch the race from the stand just as he did to-day.

The prettiest struggle of the race was in division 5C, in which there were five starters. These included a special National, rated at 50-horsepower and driven by Len Zengel, who drove last year's winner, a 6-cylinder Chadwick; a pair of Loziers, driven by Mulford, who piloted the second car last year, and Grant, who was at the wheel of the Alco entry which won two Vanderbilt cup races; and a pair of Mercedes cars, rated at 90-horsepower, driven respectively by Spencer Wishart, son of the New York millionaire banker, and Wallace.

The National was only prominent for two rounds when tire troubles intervened and gave it a handicap that could not be overcome. Three different times during the race this car had to stop for tire changes and each stop occurred at a time when it might have had a chance to displace some of the leaders. It was second in the race and first in its class at the end of the first round, but fell back to third place in the next lap. Then came the tire trouble, which was aggravated by its coming about 2 miles from the pits, causing Zengel to drive slowly for that distance and this delay, together with the time spent in making the change, lost something like 5 minutes for the car.

For fourteen rounds the car went along smartly and was within striking distance in round eighteen, when the tires went bad again and the car was laid under still more handicap. Round twenty found it in trouble again, but Zengel finished smartly in 205:59.36, making the last lap in 7:45.

Lozier No. 3, Mulford, ran a brilliant and consistent race. The car started at moderate speed and was not placed until three laps had been made. Mulford maintained an average speed of 7:50 per lap for the first twenty rounds. Two rounds during mid-race were run on weakened tires, but the pilot kept going smartly until the Benz waved the distress signal, when both cars went to the pits. Mulford's crew outdistanced the repairmen of the Philadelphia car in making the change and when the pair returned to the contest, the Lozier actually had gained over 1 minute on its rival. This, however, did not serve to improve its position, as the Mercedes had taken full advantage of the tire trouble to dart into the lead, leaving the Lozier in third place. In round twenty-three the real, heart-breaking mishap occurred from the Lozier viewpoint, as Mulford was again obliged to change tires, dropping back to third place after having wrested second position from the Mercedes in the preceding round. The last laps were negotiated in about 7:40 each, which was not fast enough to get the money.

With regard to the protest filed by Mulford and sustained by Referee Dunlap, the situation developed that if Wishart had stopped to pick up his mechanic, the chances are that the Lozier would have beaten the German car. Of course there is no way to determine just how much strain was removed from tires and mechanism of the Mercedes during the partial round in which it did not carry its full load, but racing experience proves that it amounted to something.

Lozier No. 9, Grant, experienced tire trouble frequently at all stages. In spots this car was estimated to be making 90 miles an hour, which may account for the tire trouble. The car had sparkling speed throughout, but finished over 10 minutes behind the Benz.

Mercedes No. 17, Wishart, had clear sailing all the way. The car made only one slow round, lap twenty-two, when tires were changed, making the time for the round 11:14. It was among the first three from start to finish and in lap eighteen looked to have a strong chance to beat out Bergdoll's Benz. From there to the end, however, it faded out a trifle and after the mishap to its mechanic, was not so sharply driven as in the earlier



After the race hundreds of thousands of spectators flocked over the course



Grant's Lozier leading De Palma's Mercer on the Neill Drive turn—note way crowds were kept back from the course

stages. Its final time was 200:11.42, which is considered faster than the time of previous winners of the classic.

Mercedes No. 18, Wallace, experienced tire troubles and ran through the last ten laps with its engine making signals of distress. No formal reason was given for its poor showing, but it was surmised that either ignition or carbureter was at fault. The car was running at the end but only completed twenty-two laps.

In Division 4C there were three starters, a pair of Nationals and a Stutz. National No. 16, Disbrow, jumped away in the lead and was first at the end of each lap to the finish. The car ran smoothly throughout and gradually increased its lead to the end.

At no time during the race did it make any prominent bid for the general sweepstakes, but it dashed along with a beautiful certainty under the skilled hand of its pilot. Its time was 208:22.32, just under 60 miles an hour on the general average,

and ahead of the winner of the general sweepstakes of last year.

Stutz No. 10, Anderson, ran an impressive race, never seriously threatening Disbrow's mount, but always shooting at the winner on the long stretches of the course. The Stutz did not have a moment of mechanical trouble and no tire trouble to speak of. It was well handled and its showing attracted a vast amount of attention. It lay in third position in the class until lap 24, when it forged ahead into second place and so it finished. The time of the Stutz was 220:23.05.

National No. 6, Herr, car and driver the same that won the Illinois Cup at Elgin, finished third. Herr followed Disbrow rather closely for twenty-three laps and looked to be surely entitled to second place in the class when a bad tire change caused him to make a slow circuit in round twenty-four and the Stutz displaced him. There was a thrilling duel between National No. 6 and the Stutz in the last rounds, but Anderson had an advantage of 10 seconds in round twenty-four and maintained it to the wire.

Division 3C had seven entries including Cole No. 4, Basle; Mercer No. 5, De Palma; Case No. 7, Jagersberger; Mercer No. 11, Hughes; Ohio No. 12, Parker; Bergdoll No. 14, G. Bergdoll, and Ohio No. 19, Matthews. Bergdoll No. 14 was scratched before the start and the other six formed the field.

Mercer No. 11, Hughes, won all the way and finished all alone in the class. This car was second at the end of round one, being 1 second behind De Palma's Mercer at that stage. But from the second round to the end, Mercer No. 11 stayed out in front. It had no troubles of any kind and simply sailed along at a gait that rivalled the Chadwick's time in 1910. The Chadwick is a Class 6C car, with more than twice the piston displacement of the Mercer. The final time of this car was 209:45.30.

Ohio No. 19, Matthews, was second, finishing twenty-two rounds before the race was stopped. Mercer made a creditable showing from the viewpoints of reliability and speed, but did not show enough of the latter quality to develop anything like a struggle in this class.

Ohio No. 12, Parker, completed twenty laps before the checkered flag announced the finish. It had three very slow rounds, the result of tire trouble far from the pits or stations, but was running well at the finish.

Cole No. 4, Basle, finished six laps at moderate speed when carbureter troubles developed and the car retired from the contest.

Mercer No. 5, De Palma, looked like the winner of second place in this class for twenty-two rounds, when a broken steering knuckle caused its retirement. The mishap occurred in front of the stands at the end of round twenty-two and the driver wriggled the disabled car over against the stand after passing the line. For the first fifteen laps this car was only a few seconds behind its teammate, but beginning with that round it fell back until the final mishap put it out of the running.

Case No. 7, Jagersberger, finished thirteen laps at fair speed and was not completely out of the race when it became unmanageable on Sweetbriar hill and, skidding, struck a post. This

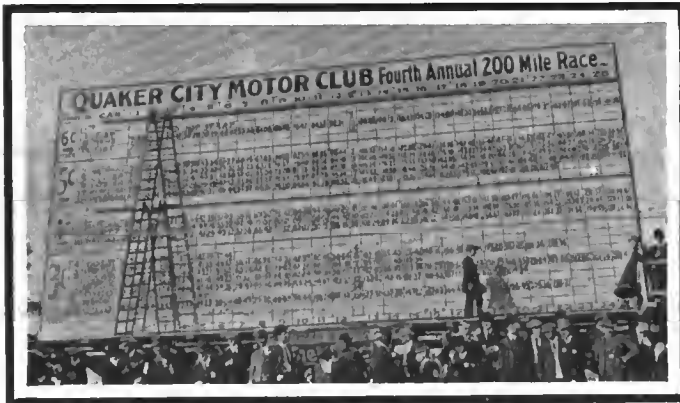

The Quaker City Timers' Club had the scoreboard situation well in hand



Grant's Lozier overtaking Mercer No. 5 at the head of the stretch



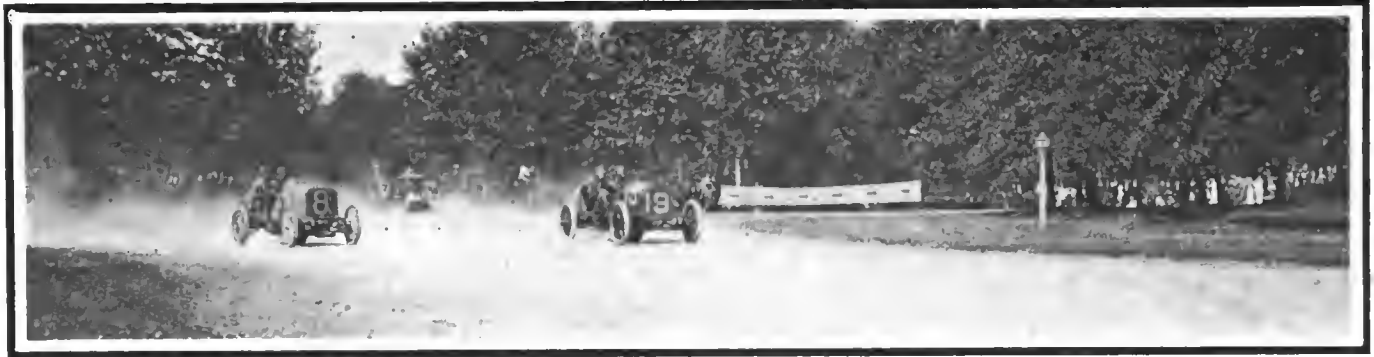

The Bergdoll Benz passing Ohio, No. 19, on the turn around the base of George's Hill

resulted in a broken spring and called for the retirement of the car.

Of the sixteen starters in the race, nine finished and three were running when the final flag was dipped.

The race was the fourth annual event staged at Fairmount Park under the auspices of the Quaker City Motor Club. It was originally scheduled to be held on Saturday, October 7, but a wet and slippery course caused the race to be postponed until Monday. Under the conditions, the event was divided into four classes, coming within the limits of Class C.

To each division winner a prize of \$1000 will be paid and to the Benz driver goes the sweepstakes prize of \$2500. In addition to these purses there were the usual number of accessory prizes of various descriptions, the whole amounting to not far from \$10,000.

The subscription for entry was fixed at \$500 per car and as there was eighteen cars entered, the proceeds of entry amounted to \$9000. The purses given by the club amounted to \$6500.

While the crowd was not nearly as great as in other years, the stands were well filled and it was estimated that the receipts would be about \$10,000 net, after deducting expenses. Under the conditions by which the City of Philadelphia patrols and polices the course, the net receipts from the sale of seats and privileges goes to organized charity.

The field for this year's race was small in comparison with that of 1910, when thirty-two cars started, and consequently the revenue of the club was much abbreviated. This was the result of several factors, one of the chief being the dispute that arose over the question of who should start the race.

After several heated colloquies with the A. A. A., in which ultimatums were passed to and fro, the original choice of the club, G. Hilton Gantert, was selected to officiate once more.

This decision was reached at a meeting of the full membership of the club, at which a vote was taken to instruct the directors to maintain Mr. Gantert in the position of starter at all hazards, even going so far as to promise financial aid to the extent of \$20,000 in order to fight the case in the courts if the necessity arose for such action.

It was charged that the other candidate, Fred J. Wagner, had not supported the race this year or in other years. A letter was received by the club from the Contest Board outlining the necessity of having a man of national reputation handle the flags at the race and pointing out the disadvantages under which an incompetent man would work. This was construed by the club as supporting Wagner's claims and discounting those of Gantert and was considered an ultimatum, as the letter contained a clause cautioning the club to accept the services of the man with the national reputation or suffer the revocation of its sanction.

Robert P. Hooper, president of the A. A. A., was present at the meeting and immediately communicated with national headquarters urging some modification of the terms of the ultimatum. About this time Mr. Wagner withdrew from the contest in the interest of harmony and Mr. Gantert got the job.

The race itself was very successful from every point of view.

It was truly run, the fastest car winning under deft handling. There was a distinct winner in each of the four classes. In accordance with the good fortune that has ever surrounded this race, there was not a major accident of any kind. The police, 2000 strong, maintained a clear, safe course throughout the running of the race. The day was fine and clear with plenty of warm sunshine and a gentle breeze. The course was not in top-notch condition, being rough in some places and dusty in others. There was very little crowding on the part of the contestants and no mishap resulted from what was experienced.

The only jarring element was the disqualification of the Mercedes car. In this regard it may be said that professional races, such as the annual Fairmount Park events, are run according to binding rules. These rules are framed to give equal justice to all the contestants and the section that specially applies to the case of the Mercedes provides that the driver and mechani-

(Continued on page 643.)

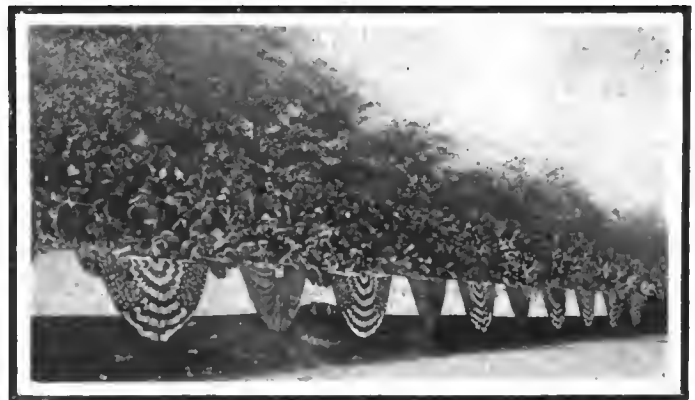

The race was well attended despite the postponement



There were bluecoats galore to keep the crowds within bounds



## New Palace an Architectural Gem

**H**OUSED in one of the most beautiful buildings in New York, the automobile show to be given under the auspices of the National Association of Automobile Manufacturers, January 10-17, promises to be a vast success.

With a typical line of cars represented, consisting of the cream of the independent manufacturers as well as of the members of the N. A. A. M. that are not connected with the Automobile Board of Trade, gasoline pleasure cars, electric pleasure vehicles and commercials and gasoline deliveries and trucks will be shown. They are sufficiently numerous and typical of all branches of the industry to form a fitting companion-piece to the Madison Square Garden show.

All but two of the passenger automobiles to be displayed will be shown on the main floor of the new Grand Central Palace.

The second floor will be devoted to the exhibition of trucks and commercials of various kinds, together with the two passenger cars that could not be accommodated on the main floor for reasons of space.

The third floor is to be used for exhibiting accessories.

In the main, the spaces assigned to the various companies at the drawing last week will be occupied by them during show week, but there will be some changes as usual. Besides these, there will be quite a number of additions to the exhibitors and perhaps a withdrawal of two. The changes generally result

from the desire on the part of exhibitors to swap spaces and even during the drawing there were several concerns negotiating for an exchange of spaces.

The first drawing resulted in filling the big main floor with pleasure-car exhibitors and considerably more than half filling the second floor with commercials. Mr. Miles announced after the meeting that there would be enough applications filed this week to take up all the available space in the truck section of the Palace show.

There was only one protest filed following the distribution of space and that resulted from the rule that had been adopted, placing the commercials on the second floor. The Gramm company objected strongly to



(Upper) Exterior view of New Grand Central Palace. (Lower) Grand stairway leading from street level to main floor



this arrangement, claiming that the space awards should have been based upon the number of shows that the companies had participated in and the amount of business done by them.

The protest having been overruled, the company selected a prominent space at the corner of the open court.

As compared with last year, the situation was a love-feast. Represented at the drawing were prominent members of the trade, who formed the backbone of the independent movement in the past, discussing positions in the exhibition hall with the wheel-horses of the parent organization. Every concern that makes good automobiles was sought for and their representatives responded in large numbers to the call.

Some of the spaces secured on the main floor by concerns that are just making their debut are notable for their size and position. This is particularly true of the Hupp Corporation and the Stutz.

The building fronts on Lexington avenue and is twelve stories high. Around the top pair of stories is a colonnade effect that gives a Moorish aspect to the structure.

Entering from Lexington avenue, visitors ascend a broad stairway to the main floor. From the top of the stairs the hall stretches away for 200 feet to the rear wall of the building. To left and right are the passenger elevators flanked by prominent exhibition spaces. Back on the Lexington avenue end of the room, extending from one wall to the other there are show spaces. but the solid body of exhibitors will be ranged about the great hall between the top of the stairs and the Depew Place side.



(Upper) View of the colonnade on the main floor, showing detail of pillars.  
(Lower) Looking toward head of grand stairway from main hall

The tone of the interior is white combined with cream, the latter color being furnished by the stone work in the pedestals of the pillars and in some of the painted surfaces. The lights are set into the ceiling in such a way as to avoid glare and at the same time shed an ample volume of radiance. The whole floor is a giant quadrangle, surrounding a smaller one, in the form of an open court of great size, situated well toward the rear. This court is open to its full width as far as the ceiling of the second floor and pierces to the top of the third floor in reduced dimensions. Ranged in pairs, laterally through the hall, are two series of pillars of monumental size and massive beauty.

Besides these there are numerous pillars of smaller size in all parts of the building.

These serve to support the exceedingly heavy structure and are not unsightly. But they do serve to cut up the hall and they do obstruct the general view.

The available space on the second floor is less than on the main or the third floors, this being due to the space lost on the second floor by reason of the open court. However, this is partially balanced by the space gained over the stairway. The third floor is still larger because the court is reduced to small size and it constitutes the only break in the floor which measures 194 by 268 feet.

Near the northeast corner of the building are the freight elevators. The shafts are covered with building material except for the side where entrance and exit to them is had.

The applications for space indicate that about 250 different



View of the main hall of the New Grand Central Palace, looking across the Colonnade

models will be shown. The exhibitors sought space to accommodate from 2 to 8 cars and 55 bidders were located in the building. There will probably be a dozen additional exhibitors, thus making four the average number of cars displayed.

The plan for decorating the interior is still unsettled. As the building stands it requires very little in the line of beauti-

fication and it has been practically decided that simplicity will prove more effective than ornateness.

The building is being used this week for the electrical show and the promoters have been exceedingly sparing of decoration. The effect is very good.

The executive offices of the company are located on the

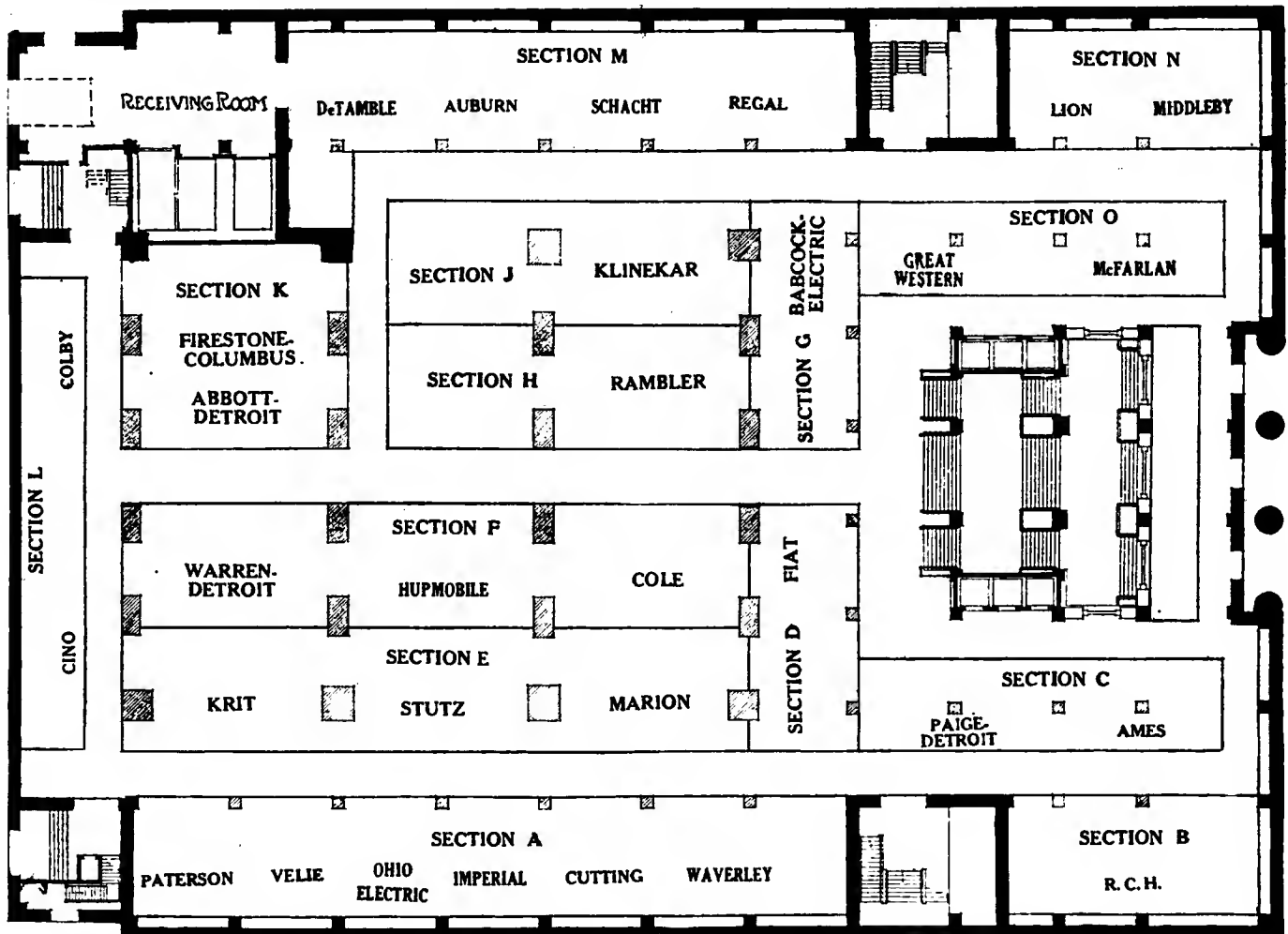

Floor plan, showing how the main floor exhibits will be installed at the 12th annual N. A. A. M. Show in the Palace, Jan. 10-17, 1912



Giving an idea of the decorative effects on the second floor of the New Grand Central Palace

ground floor in the southeast corner and cut off nothing from the main floor, thus diminishing in no way the available exhibition space.

The floor space of the exhibition part of the new Grand Central Palace is something over 120,000 square feet. This total is considerably greater than the exhibition space of any other

building devoted to shows in the United States. Despite this fact, the division of the space into three floors and the presence of so many pillars in each does not give the effect of such a vast amount of room. The architectural impressiveness of the main floor is not carried out in the upper floors of the structure in the same measure.

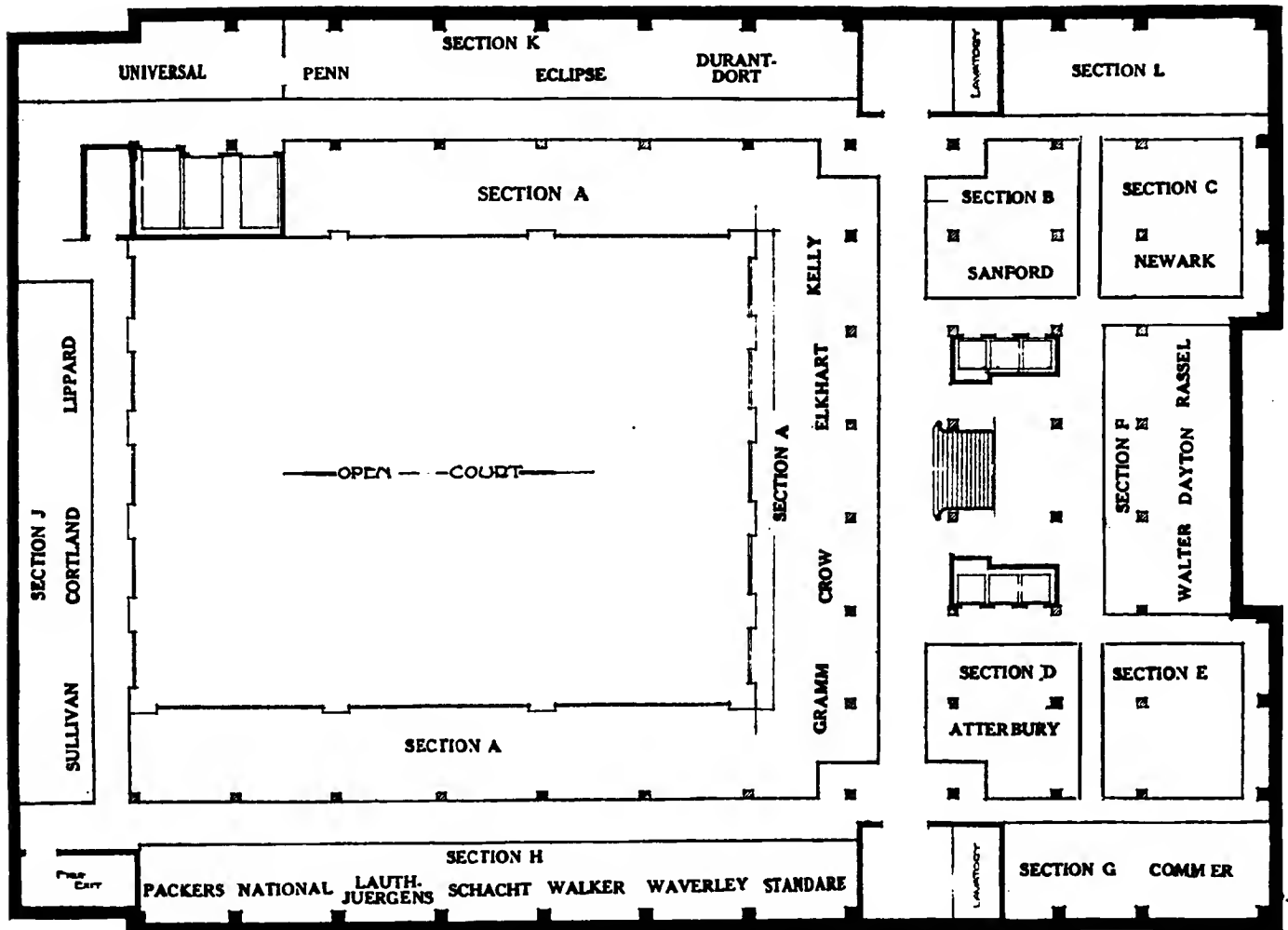

Plan of the second floor exhibits at next winter's N. A. A. M. show in the New Grand Central Palace

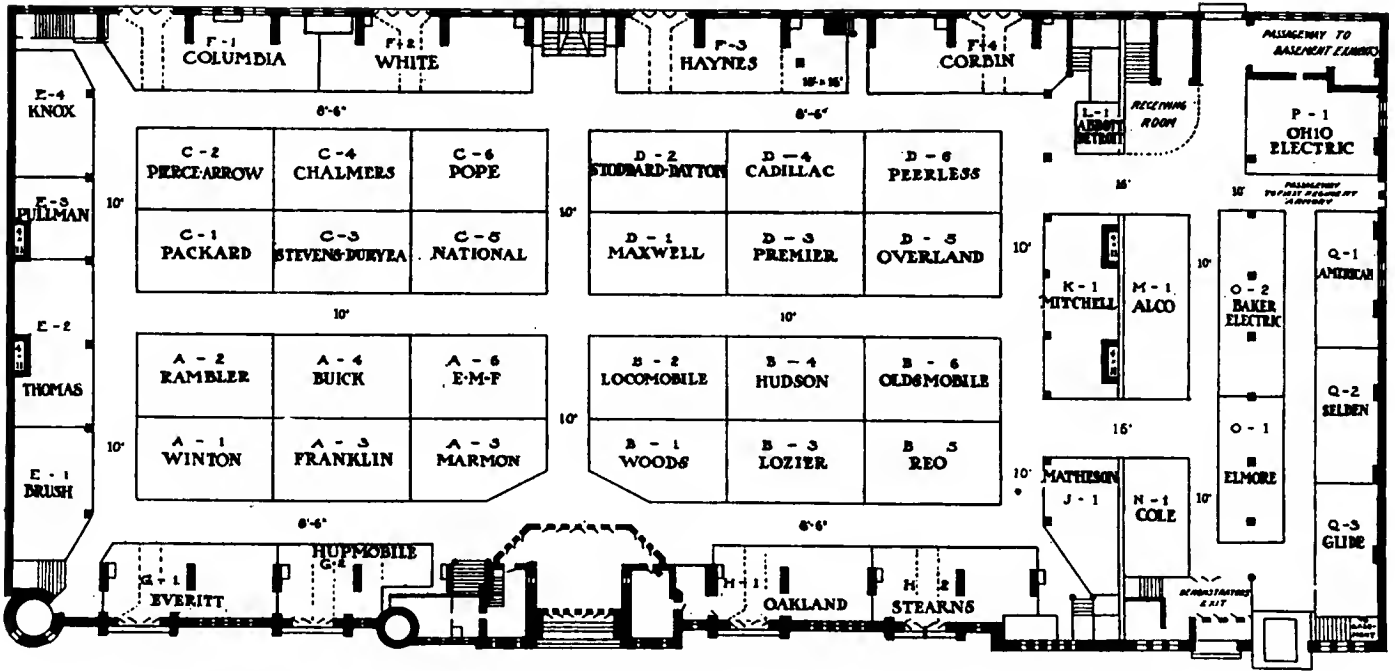

Chart of Chicago Coliseum and Annex, showing where pleasure cars will be located during N. A. A. M. Show, Jan. 27 to Feb. 3, 1912

# The N.A.A.M. Shows at Chicago



CHICAGO, Oct. 10—Although no announcement has been made by Manager Miles as to the principles and scheme of decoration for the Coliseum and Armory shows in Chicago in January and February, it is a foregone conclusion that both of these shows will be up-to-date in every respect. The pleasure car show will open on Saturday, night, Jan. 27, and continue until the following Saturday night. As

soon as the doors close on it the exhibits will be removed and the following day the commercial car exhibits installed so that the commercial show can be opened Monday afternoon or evening, Feb. 5, and will continue until the following Saturday night.

The setting for both of these shows will be identical with former years. Two buildings will be required. The Coliseum on Wabash avenue will be the big exhibit hall; the second building is the First Illinois National Guard Armory, which is on Michigan avenue. The rear entrance of the Coliseum opens onto the alley leading to the rear entrance of the Armory, so that both buildings can be combined by constructing an enclosed walk along one inside of the alley. Tickets of admission to the Armory are given when leaving the Coliseum by the rear entrance and *vice versa*. This arrangement makes the two buildings practically one and gives the exhibitor in the Armory as good a chance at exhibiting his wares as his rival in the Coliseum.

As in previous years during the first week, the main floor of the Coliseum, the Coliseum annex to the south end of the Coliseum and the annex basement will be given over entirely to pleasure cars; the gallery of the Coliseum and the annex will be placed at the disposal of accessory manufacturers. In the Armory the same rule will hold; namely, cars on the main floor and accessories in the gallery. It is expected that the majority of the accessory exhibitors who will show during the pleasure

car week will leave their exhibits for the commercial display during the following week. There will be, of course, not a few whose accessories are not intended for trucks or delivery wagons and they will not remain. The tire makers will undoubtedly change their exhibits, the pneumatics of the first show being replaced by the huge solid rubber truck tires for the second week's exhibition.

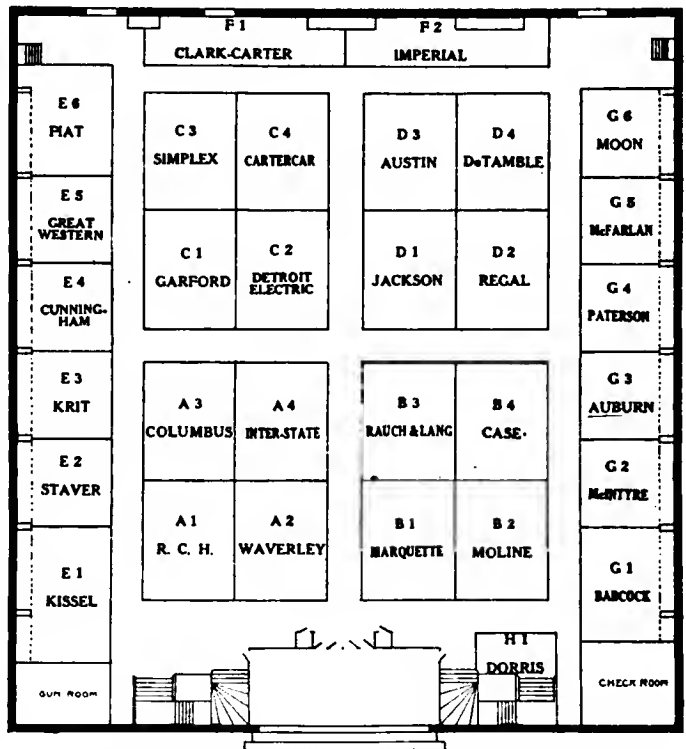

How pleasure cars will be distributed at the First Regiment Armory



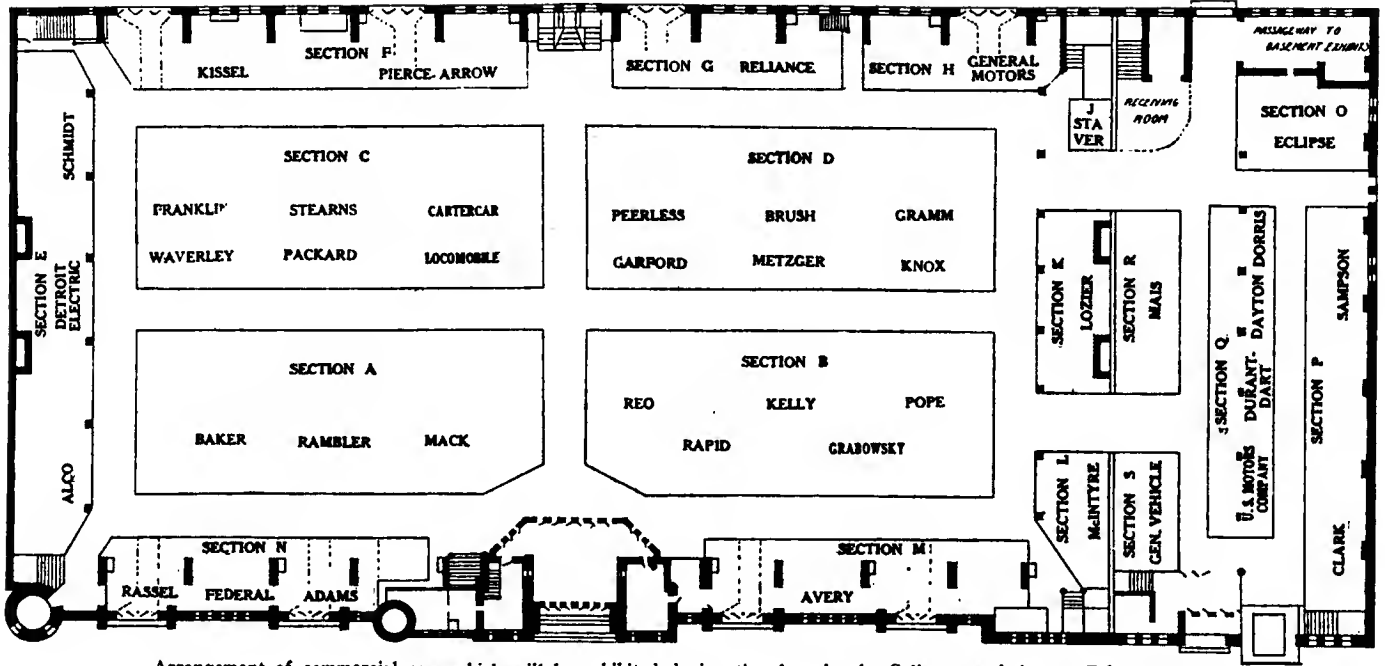

Arrangement of commercial cars which will be exhibited during the show in the Coliseum and Annex, Feb. 5-10, 1912

The Chicago show has since its inception been a wide-open exhibition and will be so for the coming year. In the days of the A. L. A. M., when New York had its licensed show in one place and its independent show in another place, these licensed and unlicensed makers were exhibiting side by side in the Coliseum or Armory; and next year the Board of Trade members will be side by side with those who are not members of this organization. Barriers are entirely removed; it is an out-and-out national show. In the selection of exhibit spaces priority of selection has always been given to those makers who have been the oldest exhibitors at the Chicago shows. Because of this scheme it is possible for nearly all of the old companies to group themselves on the main floor of the Coliseum. In this way one of the smallest makers is often lined up against some

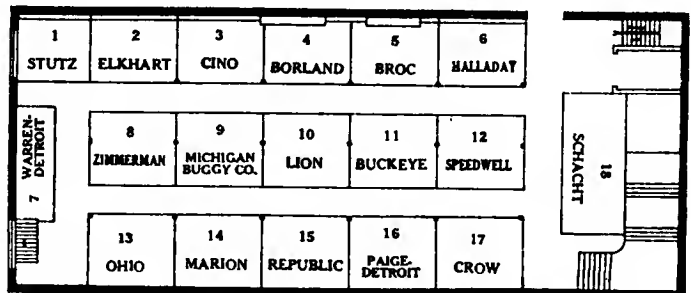

Plan of basement of Coliseum and layout for pleasure cars

of the biggest producers of high-priced automobiles to be found in the country.

In the matter of show decorations, Manager Miles has always shown special versatility and a good scheme is anticipated for the coming show. He was the introducer of the uniform scheme of decoration, which has been adopted all through America and is being used in many of the big exhibitions in Europe.

### Chicago Show Week

CHICAGO, Oct. 9—Chicago is trying an experiment this week which, if successful, will be copied by other cities. Affairs somewhat similar to it have been held, but no other city has such a stage as is afforded by the local motor row, 2 miles in length. The experiment is the fall opening of the Chicago Automobile Trade Association, which has taken the form of a combination outdoor and indoor display. The exterior of the show consists of Michigan avenue, decorated at night by countless numbers of incandescents strung crosswise of the street and with handsome lighted posts at each corner. The stores are decorated uniformly with autumn leaves, potted palms and flags and, taken as a whole, the row presents a handsome appearance.

Nearly every concern has on view the 1912 models and every effort is made to bring out the crowds at night, when the stores are kept open until 10 o'clock, the idea being to get the names of prospects who can be worked on during the dull months of Winter. To encourage the people to visit the row the Trade Association is running a trackless trolley made up of demonstrating cars which carry spectators from one part of the row to another, provided they secure tickets from some agent, who takes the name before handing out the pass.

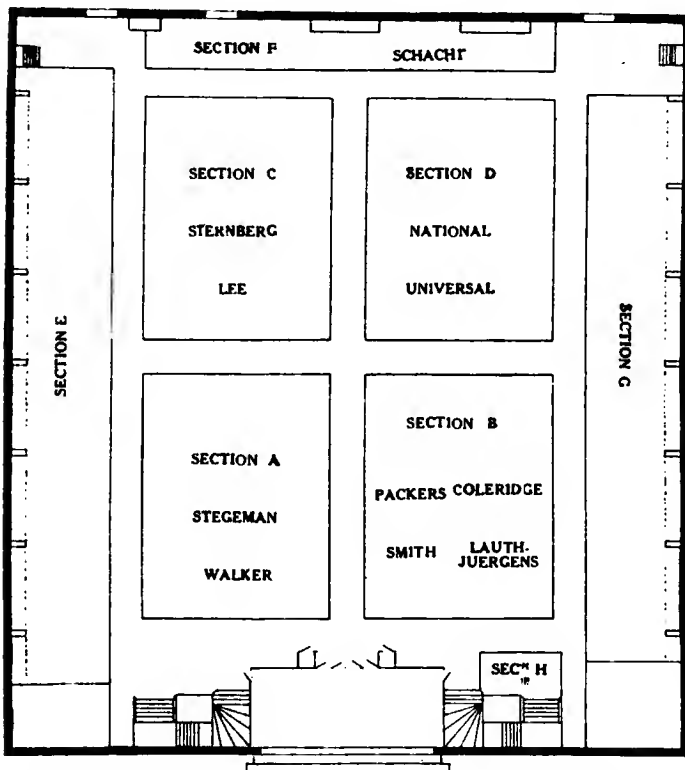

Space arrangements for commercials at the First Regiment Army

# Crossing the Canadian Rockies Feat

## A Glorious Vacation Trip

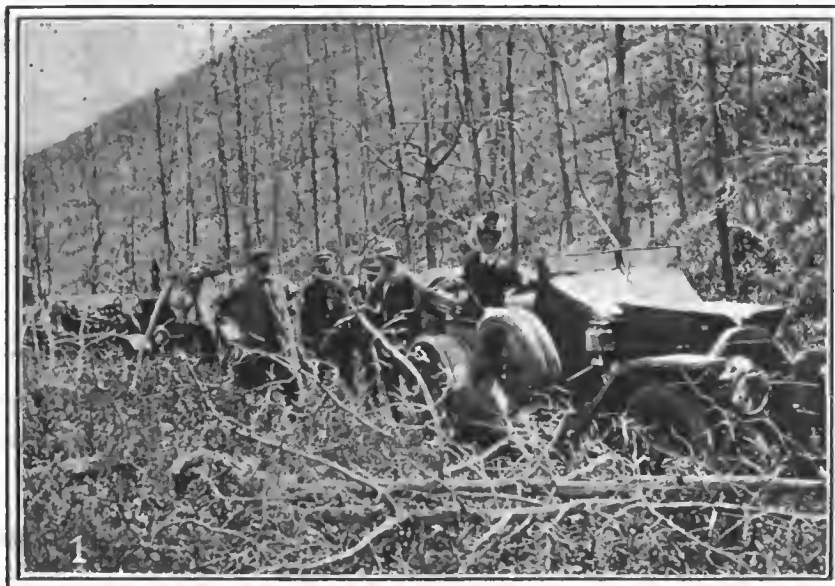

- 1—At the summit of the Crow's Nest Pass on the backbone of the continent  
 2—Some of the going was equal to that afforded by fair country roads  
 3—Where a boiling trout stream has cut its way through the living rock

CROSSING the Canadian Rockies from Calgary to Windermere, a feat never performed heretofore in automobiles, two carloads of tourists, consisting of members of the Calgary Automobile Club, recently enjoyed an experience that was glorious.

They spent three weeks on the trip and only traveled 1,133 miles, but for eight days the party camped and fished the streams and lakes high in the heart of the mountains. According to Herbert Mapes, one of the party, the roads and trails were extremely difficult, but the magnificent scenery and the pleasure of the trip more than repaid the pains and trials that were suffered through the racking of the bad roads.

Guns, fishing tackle and a complete camp outfit were carried. The largest mileage made in any day was 128 miles, the distance from Calgary to MacLeod. After getting up into the hills the average distance traveled each day was about 50 miles and on several days the route traversed was cut down to 25 miles.

Leaving MacLeod the way led past the little city of Frank, B. C., where once stood another village of the same name. Deep under boulders and earth that slipped upon it from the mountain tops the former village and 80 of its inhabitants are buried. This part of the route is very dangerous, even to-day, because the formation of the mountain surface is not secure and slides are of daily occurrence.

The next day found the party augmented by another automobile and the three cars climbed the terrific grade and narrow, rutted trail to Crow's Nest Pass, which is at the summit of the continental divide. Looking back from Crow's Nest the party saw streams and brooklets that eventually empty into the Atlantic Ocean, while to the west the watercourses flowing through the broad valley that lies between the Rockies and the Selkirk foothills, trend to the Pacific.

On the very summit the tourists found a house, from which the rain is shed on one side into the Atlantic Ocean and from the other the dripping moisture finds ultimate rest in the Pacific.

Legend says that two other automobiles once tried to surmount Crow's Nest, but sticking in the mud, both had to be



towed to the summit by the aid of horses. In this case all three cars reached the top by the power of their own engines. Mr. Mapes estimated that the grades at their steepest pitch approximate 45 per cent. After passing Crow's Nest the trail led downward to the floor of the valley, from which stretched away the foothills of the Selkirks.

The route across the mountains was through a country where inexpressibly grand scenery is the ordinary thing. Bald crags, thousands of feet high, stand out from the grim mountain sides, while along the trail, turning the blackness of the highland lichens to green are numerous springs and brooklets that trickle toward the valleys to form the tumultuous trout streams and shimmering lakes which abound in this region.

Canyons and heavy woods, where the most vivacious members of the party were hushed by the grandeur of the silent pines, were incidents of the downward trip, which was concluded at Krag.

The next day the party proceeded to Windermere, 117 miles, requiring over 12 hours' steady running, and the following day

# of Calgary Automobile Club Members

## Over Continental Divide



4—In reaching Lake St. Mary's the cars had to traverse this road  
 5—Just before Waldo, new road construction was passed by the party  
 6—Less than two hours to midnight this picture was taken near Krag

The perpendicular climb from the west side of the plateau to the summit of the Crow's Nest is 610 feet and the cars made it in 20 minutes over a trail barely wide enough for the tread of the wheels, and at the top found the way down blocked by a load of coal, which was being dragged up to the summit of the pass by a 4-horse team. In order to get around this obstacle the wagon had to be hauled out so that its wheels on one side touched the edge of a precipice bounding a 90-foot drop. The animals were then unhitched and by dint of tight squeezing and the loss of some paint from the tonneaus the cars managed to pass.

There was not a single unpleasant incident during the entire trip, if one may disregard the meeting with the coal team. The tourists enjoyed every minute of it, and all declared that they intended to repeat it next Summer.

### Southland Calls to the Tourist

So powerfully has the Wanderlust caught the motoring public that inquiries have already begun as to the delights of a tour to the Southland.

And the answer is that the trip makes a real experience and a pleasant one. The South has awakened in some measure to the importance of good roads, so that occasional stretches will prove excellent, while the average roads are tolerable. Two routes in the Automobile Blue Book have been very fully detailed in the 1911 edition, Volume 3, and no tourist should attempt the trip without it. One of these routes is known as the National Highway and the other as the Capital Highway. More parties than the uninformed would suspect have made the trip.

Of course the great charm of the tour is the scenic beauty of the South. In Virginia "where cotton fields touch the edge of the swamps, where jasmine blooms on the rail fences, and peach trees by every cabin, the cardinal lifts up that voice of the troubadour, so gay, so debonair." In the Carolinas is the glorious belt of pines. And finally, in Florida, is the playground of the motorist.

was spent in making an ineffectual side trip to Horsethief Creek, where it had been intended to camp for several days.

This was not done, however, and camp was made on Lake Windermere for the next four days. There was little fishing to be had, and after enjoying the fun of living out in the open for that period of time the party entrained again and proceeded to Cranbrook and from there to Lake St. Mary's.

The return trip, which really should be figured from Windermere, was somewhat longer than the outward bound journey. After leaving the lake the way was through Cranbrook, Fort Steele, Wardner, Baynes Lake, Elko, Morrisey Hills, Fernie, Hosmer, Crow's Nest, MacLeod and into Calgary.

The trip required just 21 days and was staged among the most beautiful scenery to be found in Alberta and British Columbia, if not in the whole world.

The cars used by the party were a Cole and a Stearns, while the car that joined the Calgary tourists before reaching Windermere was a Hudson. On several of the days the party covered too much territory to enjoy to the uttermost the scenery.

# Pulverized Coal--a New Fuel

**Is Thirteen Times Cheaper than Gasoline--Offers Good Inducements for Commercial Work**

BY PROF. WILLIAM D. ENNIS.

**U**NDER fairly intelligent operation, and with reasonably good luck, the leading items of running expense in connection with an automobile are fuel and tires. Which of these two is the more important depends upon many factors, such as weight and design of car, roads, speeds, size and type of tires, care in running, etc., but in few applications is the cost of fuel other than an important item.

The fuel in this country is usually gasoline. At a cost of says, 20 cents per gallon of about 140,000 B.t.u. heat value, we buy in gasoline 7,000 B.t.u. for 1 cent. With a thermal efficiency of the motor of 15 per cent. (from heat in fuel to work or power at the tire) we obtain in actual pulling power  $7,000 \times 0.15 = 1,050$  B.t.u. for 1 cent. If a fuel were available which afforded this amount of developed horsepower at a cost of 1-6 or 1-7 as much, the expense for fuel would be reduced to 1-6 or 1-7 its present usual rate in the operation of automobiles, and the total cost of running would be reduced in no small degree.

Gasoline is one of the most expensive of fuels, quality considered. About 7,000 B.t.u. are obtained for 1 cent. City gas containing 600 B.t.u. per cubic foot, at \$1.00 per thousand cubic feet, gives only 6,000 B.t.u. for 1 cent, it is true; but crude (fuel) oil at 3 1-2 cents per gallon gives 40,000, and coal of 14,000 B.t.u. heat value at \$3.00 per ton gives 93,000, or 13 times the return from gasoline. The railway locomotive uses such coal; the automobile is handicapped by the necessity of using gasoline.

## Commercial Uses of Pulverized Coal

This seems to be solely a question of convenience. High-priced fuels are sometimes used on account of their small bulk, as when a warship employs fuel oil at twice the cost of coal, because a cubic foot of such oil may weigh 60 pounds and represent, potentially, 1,250,000 B.t.u., while a cubic foot of coal weighing 50 pounds, would yield only 700,000 B.t.u.—little more than half as much.

In certain industrial applications, where conveniences or control of combustion necessitates the use of fuels other than ordinary coal, there is keen competition between liquid fuel, natural gas and pulverized coal. Natural gas is not everywhere available, and the supply is everywhere decreasing. Liquid fuels, in this part of the country, cost on the average, per available unit of heat, about twice as much as pulverized coal, which is consequently largely employed in cement burning and for various heating furnaces. A fourth competitor, which seems destined eventually to supersede this fuel, is industrial gas; but excepting in blast furnace work, this has not yet been developed to any extent.

Powdered coal is coal which has been so finely ground that it looks and acts not unlike gunpowder. The coal selected for pulverizing is usually a high grade, highly volatile and fairly dry bituminous—one which along the Atlantic seaboard sells at a rather high price. Contrary to a prevailing impression, pulverizing is not likely to provide a method for utilization of the waste products of the mines. The grinding is usually expected to reduce the coal to 60 or 80 mesh; sometimes to still smaller size. The pulverized product is irregularly inflammable. A lighted match, thrust into it, will be extinguished; but a floating fog or cloud of the dust in a badly ventilated room may ignite and burn explosively in consequence of accidental local overheating

or of contact with spark or flame. Several accidents have occurred from such causes.

## Combustion of Powdered Coal

In a furnace this fuel acts like gas or oil, giving an intensely hot, pervasive and controllable flame, which may be easily adjusted to develop maximum combustion efficiency. Like all soft coal, it burns with a long flame; but smokelessness is possible without special combustion chambers unless the load is heavy or rapidly variable. The stream of coal is swept or blown into the furnace and is of course quite invisible. If allowed to strike a bridge wall or arch, the localized high temperature and blow-pipe action are highly destructive.

The ash (from such a soft coal as is usually employed for pulverizing), is a heavy fine powder, for which there are applications in the arts. In clinkering habit it resembles the ash from the unpulverized coal. If a fuel is used the ash of which does not clinker in ordinary operation, it will not clinker after pulverizing. If an automobile can run 14 miles on 140,000 B.t.u. of gasoline, using, say, 1-2 pound of gasoline or 10,000 B.t.u. per mile—and the same machine should require (for reasons which will appear) 1 1-2 pounds of pulverized coal (20,000 B.t.u.) per mile—about 0.15 pounds of ash would be produced for every mile traveled, or about 1.66 cubic inches. On a 20-foot roadway, for every 10,000 automobiles which passed there would then be deposited an ash layer equivalent to a uniform thickness of 0.0011 inch across the whole width of the road. A long time would be needed to macadamize the road with powdered ash!

This fuel burns without odor and (as has been stated) may be burned without smoke. With an ash production of 1.66 cubic inches or 0.15 pounds per mile (say 0.2 grain per foot), it could also be called dustless.

## Relative Efficiencies

The powdered coal weighs about 81 pounds per cubic foot, containing about 1,130,000 B.t.u. A cubic foot of gasoline may represent just about the same heat value; so that from this standpoint there is no difference as regards storage capacity. But if a heat unit from gasoline gives more power than a heat unit from coal, then there is a difference to be considered.

Gasoline is burned in an internal combustion motor, where it may easily develop a thermal efficiency between 15 and 20 per cent. Any immediate application of pulverized coal would have to contemplate the burning of that fuel in a steam boiler which should drive a steam engine, the combined efficiency being probably not much over half that of the gasoline motor. For a given radius of action, then, the room for fuel storage would have to be about doubled if the coal were used.

## Pulverizing Processes

For over a century the possibility of an engine using a solid fuel in an internal combustion cycle has been intermittently discussed. Some engines of this type have even been built and run. Solid gasoline is one of the most recent developments along this line. If pulverized coal could be employed directly in the cylinders of an internal combustion engine, it would stand on a parity with gasoline, as far as the storage question is concerned.

In preparing soft coal, it is usually necessary to expel some of the moisture before grinding. A preliminary partial grind-

ing may precede the drying. The object of drying is twofold. It decreases the power consumption at the pulverizer, and it facilitates the handling of the pulverized material, which, if too wet, sticks like a snowball and cannot be easily transported or fed to the furnace by ordinary machinery.

The dryer is usually one employing direct heat, although steam dryers were formerly employed. The expense for fuel does not ordinarily exceed 1 per cent. of the cost of the fuel treated. Some power, also, is needed to rotate the dryer cylinder and to operate the fan which circulates the hot air; the aggregate equivalent of these amounts of power, reduced to a fuel basis, will not exceed one-half of 1 per cent. of the fuel treated in the dryer.

After drying, the coal is reduced to the pulverized condition by one of the many commercial types of grinder, all of which are expensive to purchase and maintain. The original grinding machines were burr-stones or stamp mills. The most perfect apparatus is the tube mill, which is, however, extravagant in power consumption. The centrifugal roller and ring mill is a common type at present; the rolls are sometimes replaced by hardened steel balls which run at high speed in cast metal races. Still another form of mill has radially inserted cutters which shred or tear the coal.

Very few reliable tests have been made on the power consumption for grinding; this varies tremendously with the type of mill, the size and condition of the raw material fed, and the fineness of the product. Roughly, 1 horsepower will grind to an average of 80 mesh from 100 to 200 pounds of coal per hour. In most pulverizers, the powdered product passes over a screen, any coarse particles (sometimes aggregating as much as 30 per cent.) being returned to the pulverizer. In one form, a settling chamber is provided above the grinder proper. From this an exhaust fan draws off the product by suction; its speed being regulated so that the fine particles only are removed from the mill, while the coarse are being returned to the pulverizer by gravity.

The powdered product is usually transported in closed screw conveyors and link belt elevators, and stored in small isolated bins, tightly covered.

It must be fed into the furnace continuously and by some mechanical device which mixes with it the necessary supply of air for combustion. Gravity feed is impracticable, because uncontrollable. In the Schwartzkopf system, the dust is swept in by a revolving brush. Air injectors are also employed; a supply of compressed air is then necessary. A rapidly revolving horizontal screw conveyor itself fed by gravity, is one of the most common devices. In all systems, power is required; the amount of this power is small, but its provision adds some complication; and in many systems an additional fan for supplying air is necessary.

To summarize with regard to the described standard form of equipment, pulverized coal involves an expensive plant, preferably with duplication of units; the total cost of pulverizing and feeding, under ordinary conditions, is from 50 to 60 cents per ton. The fuel is dangerous to handle and store, so that its preparation should be continuous, and pulverizing should be carried on at about the same rate as feeding. With standardization, storage provision may be surrounded with such proper precautions as to make it reasonably safe. A highly volatile soft coal must be employed.

#### Application to Steam Boilers

In connection with the Aero apparatus, these statements are subject to some modification. Here unit pulverizers are used one directly in front of each furnace. They receive the sized coal just as it comes from the cars and feed the powdered product directly into the furnace where it is to be burned. Even high percentages of moisture may be taken care of in this type of plant; but no doubt at excessive power consumption. The whole process of pulverizing is here carried on in one self-contained machine.

Any finely divided fuel is apt to be burned at higher efficiency

than solid coal. Pulverized coal in steam boilers would be on the same basis, with regard to evaporation efficiency, as liquid or gaseous fuel. Its use would largely dispense with the labor of firing ordinary coal, which might under average conditions mean a saving of 20 or 30 cents per ton. If the gross cost of pulverizing be taken at 60 cents and the labor saving at 30 cents, the net additional cost of 30 cents per ton must be contrasted with the thermal saving as between pulverized and ordinary coal. If the latter costs \$3 per ton, the 30 cent disadvantage would be just offset by a 10 per cent. gain in efficiency.

The automobile having a steam power plant already uses a liquid fuel, so that there could be no gain in efficiency. Nor could there be any saving in labor expense. In a steam locomotive, these savings might be realized; in part, at least. The independent self-contained type of preparatory apparatus would be necessary, or else pulverizing plants would replace present coaling stations and the locomotive could "coal up" as quickly as it now takes water. It might take on coal even while running. If the power for driving the feeder were derived from the locomotive boiler itself, the latter would cease to be self starting, and outside power would be necessary in order to get the fire going.

#### The Automobile

Some of these considerations apply with equal force to possible applications of pulverized fuel under automobile conditions. The figures assumed show soft coal to be 13 times cheaper, in proportion to its heat value, than gasoline. If we say that the steam plant to be used is half as efficient as the internal combustion motor (letting this rough estimate cover the cost of preparing the coal), the saving in fuel cost is still 11-13 or 85 per cent. Fuel would need to be taken on twice as frequently as at present. For commercial vehicles, making regular trips, pulverizing stations might be placed at suitable points and this ready prepared fuel discharged into a storage bin under dust-proof connections. In order to start up a cold boiler, a short period of hard feeding might be necessary.

For the ordinary consumer, the charge would be more revolutionary. The self-contained pulverizing and feeding apparatus would be a radical addition to present equipment, one which might prove intolerable. On the other hand, central pulverizing stations with generally distributed supply depots would be hard to inaugurate and would be unavailable unless inaugurated on an extensive scale. The 85 per cent. predicted saving would, however, give an opportunity for considerable profit to both producer and consumer of the fuel.

Should there be developed an internal combustion engine which could use the pulverized coal, the additional saving in fuel would be from present standpoints unimportant; but the maintenance of present radii of action and the possibility of easier arrangement for self-starting would make the fuel more attractive. It seems probable that under such conditions a strong effort would be made to adapt the self-contained preparing and pulverizing apparatus to automobile conditions. Only a small amount of prepared coal would need to be stored; but the unpulverized material for consumption would still occupy about twice the space of the present gasoline supply, so that there would be an enormous addition to the present bulk of power plant.

The outlook for a realization of an 85 per cent. saving in fuel cost by this means is obviously not encouraging, yet this is so large a saving that it necessarily obtains occasional consideration; and it is by no means impossible that we may see stage and trucking lines equipped to burn pulverized coal. Whether this will be in a steam or a gas engine is doubtful. Whether it will involve local coal supply depots and feeding spouts, or coal bins and pulverizers on the automobiles, the answer is also doubtful. It is to be hoped (and, one may say, expected), that a change of the sort, if made, may be made without adding to the present discomfort of machine occupant or passer-by, on the grounds of noise, dust, smoke, odor or any other kind of nuisance.



# Quick Methods of Car Painting

By M. C. HILLICK.

**R**APID transit processes for painting the automobile are being exploited throughout the country and promise to be largely in evidence next year. By temperament and disposition, by the teaching which the use of the horseless vehicle brings to its owner, the latter is inclined to be in a hurry.

This nervous haste follows the car into the paint shop and exacts the greatest possible speed in getting it into a new dress of paint and varnish. This brings us to the question of the briefest method consistent with reasonably durable results.

For the metal body scarcely anything shorter than a 5-day method can be offered, which represents for the first day the work of going over the surface with a coarse rubbing composition stone dipped in benzine or naphtha. Sand blasting the surface, in case of new work such as we are now considering, is the best and surest method of getting the surface free from rust or scale formation; but the sand-blast machine is not always available in the automobile or carriage paint shop, hence the need of some effective hand system which will prove at least a fair substitute for the machine. A stiff wire brush is a very good tool with which to eliminate the rust and foreign matter, but for good work, in the absence of a sand-blast machine, the composition rubbing stone and benzine is a good combination.

Having made the surface clean and receptive, apply a good metal primer, of which there are many being marketed ready to use. All things considered, these ready-to-use primers are cheaper, and, as a rule, more uniform and reliable than those shop-mixed and prepared.

The primer should be dry enough the following day to run over with a thin glaze of hand-drying putty, working the mixture on very smooth and uniform. The morning of the third day sandpaper this putty glaze sufficiently to fetch it down fine and smooth. Then apply a coat of body color, japan ground, and thinned with turpentine to flat out without any gloss. Late in the afternoon of the same day apply a coat of varnish color or glaze color. Late in the afternoon of the day following run over the varnish color with a soft sponge dipped in water and pulverized pumice stone to lay down the gloss and beat off dirt motes, etc. Then apply a coat of rubbing varnish, quick-drying, containing just enough of the pigment to preserve the natural tone of the color.

In the closing hours of the fifth day again water rub, using very little pumice stone flour, wash up and apply a coat of heavy body finishing varnish. During this time the chassis or running parts should be brought along to an equally quick finish.

This sort of finish, however, suffices for only a certain class of trade, and to make a finish acceptable to buyers and users looking for something between the cheapest and the highest-priced it will be necessary to put over the putty glaze at least three coats of rough stuff in due time, rubbing these out with composition rubbing stone and benzine, and using above the color an additional coat of rubbing varnish. This, of course, will lengthen the period for painting and finishing several days, but it will furnish a correspondingly higher class of finish.

Wooden bodies may be finished upon the same schedule outlined for the metal bodies. Upon the former apply a surfacing or glaze material bought ready to use, or made by grinding white lead through a closely set mill and then rubbing it to a working consistency with equal parts of rubbing varnish and coach japan, adding the necessary coloring matter to fetch surfacing base up to the finally selected color.

On the morning of the third day this coat or glazing should be sandpapered down, using the paper over a block, and using

for the first sanding No. 1 paper, and for the final dressing down No. 0 paper.

For better surface results omit sandpapering the glaze stuff and apply directly over it, at the rate of two coats per day, four coats of roughstuff. The day following the application of the last coat of stuff rub out with composition rubbing stone and water. Then apply, in case of most colors, two coats of flat color and a coat of varnish color, unless some one of the cake pigments is used, in which case two coats of the varnish color, or glaze color, will be necessary. Upon this, or upon the final coat of varnish color or glaze, after rubbing lightly down with pumice stone flour and water, the striping and ornamental work should be applied. Then follow with a coat of clear rubbing varnish, this in due time to be well rubbed and finished with a stout body of finishing varnish specially adapted to automobile work. This latter is an important item in any system or process of surfacing and painting which may be adopted.

The service imposed upon the varnish of the automobile is by far the most exacting of any to which varnish can reasonably be exposed, the strain upon it being, both during service on the road and in the garage, of an unusual character. Careless methods of washing and caring for the car at garages in which the very life of the varnish is threatened, and, in a measure, taken, constitute the hardest kind of service, being even worse, on the whole, than the blinding dust and the foreign matter settling upon the car in the course of road service.

All methods of painting and finishing the car should be with an eye fixed upon securing with brevity of methods the greatest possible amount of durability, along with an appearance at once neat and effective. It is not always the greatest number of coats of paint and varnish that count for most in the matter of appearance and wearing capacity. Fewer coats, and better drying and application of such coats, will insure for appearance and durability something which less careful methods and any amount of paint and varnish must fail to supply.

**BIG OIL-BURNING MOTORS FOR COMMERCIAL USE**—The largest Diesel motor so far constructed anywhere is of the two-cycle type and develops 2,000 horsepower at 167 revolutions per minute. It has been installed, together with a Diesel motor of 1,000 horsepower, by the Electrical Society of Saint-Chamond, which has heretofore received all its current from a water power plant in the Alps Mountains.—From *Le Génie Civil*, July 29.

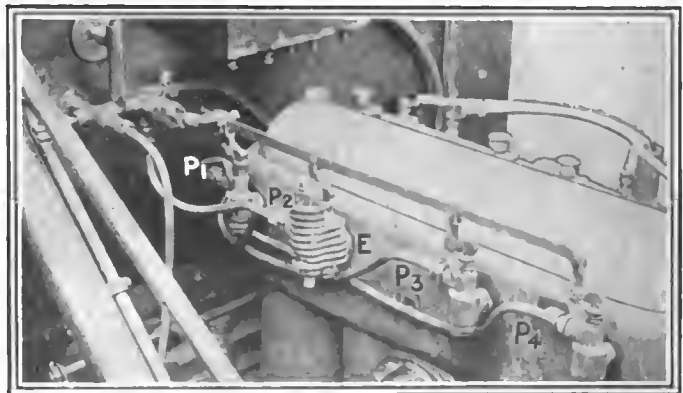

Fig. 1—Showing right-hand side of Everett motor, with self-starting device attached

# Novelties in Self-Starting Devices

**D**ISINCLINATION to work any harder than necessary has put the average motorist on the *qui vive* for anything new and promising along the line of self-starting devices. One of the more recent inventions having this object in view is that forming part of the regular equipment of the 1912 Everitt six- and four-cylinder models. This may be briefly described as of the compressed-air type, operated by a push-button on the dashboard. The supply of air pressure is taken from one of the cylinders on the explosion stroke, and in the case of the four-cylinder motor, shown in Fig. 1, it will be seen at E on the third cylinder.

The air-pressure storage tank can be filled by running the motor for five or ten minutes, after which the pump is automatically shut off. A selector valve, or distributor, operating on the same principle as an electric timer is directly connected with the camshaft. As the engine revolves this distributor exposes, in turn, four openings for the four cylinders, and air pipes P<sub>1</sub>, P<sub>2</sub>, P<sub>3</sub> and P<sub>4</sub> are led to each of the cylinders. The timing is so arranged that the air pressure from the tank passing through the distributor is admitted first to the cylinder which is at the top of its stroke.

A needle valve V<sub>1</sub>, Fig. 2, is provided on the dash for the purpose of closing the tank and connection when the car is left for the night, or for any length of time, the object of which is to guard against any possibility of leakage of air pressure from the tank. The gauge G<sub>1</sub> registers the amount of pressure available for starting the motor. When it is desired to start the motor, provided the needle valve is open, it is necessary to press on the push-button B in Fig. 2, which releases the air pressure stored in the tank, and, passing through the distributor, forces one of the pistons down, thereby causing the crankshaft to rotate. The distributor in turn opens the next valve and so on, rapidly turning the engine until the latter takes up its cycle of explosion. The pressure of the knob, besides releasing the compressed air from the tank, opens the valves that are fed from the distributor. These can be clearly seen in Fig. 1.

**GOODHART STARTER**—Another recent example along the same lines, this time from across the water, is known as the Goodhart engine starter. The device consists of a helical spring mounted on the clutch shaft, Fig. 3. This spring is wound up by the motor, which it subsequently restarts by being released. The shaft AB is cut in two and the half carrying the clutch is keyed to the boss A<sub>1</sub>, having dogs, which engage with others upon a ring C. This ring has a peripheral ratchet wheel, which can be

slid along the drum D through the medium of keys D<sub>1</sub>, thereby sliding the teeth of the wheel in and out of engagement with the pawl F mounted upon some fixed part of the chassis. The drum D contains a flat helical spring, the outer end of which is fixed thereto and the inner end to a flange B<sub>1</sub>, which is keyed to the transmission half of the clutch shaft.

The drum also carries two dogs D<sub>2</sub>, which allow of a little less than one revolution being made before they bring up against two similar dogs B<sub>2</sub>, on the flange B<sub>1</sub>. The loss of the flange

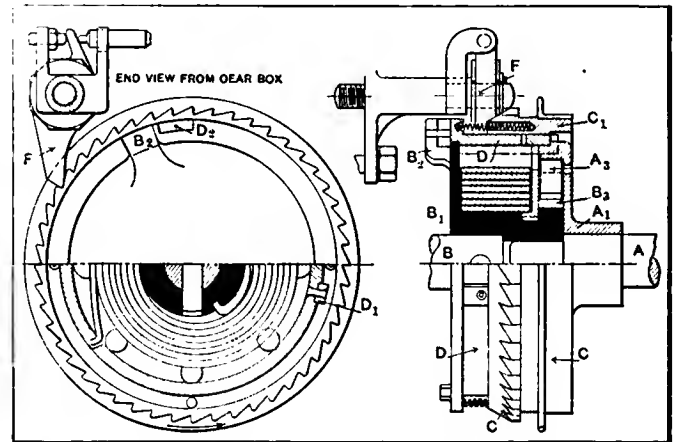

Fig. 3—Sectional view of Goodhart engine starter, an English invention

B carries a ratchet B<sub>3</sub>, which is held by a pawl A<sub>3</sub> fixed to A<sub>1</sub>. When a load is put upon the clutch shaft through the engine driving the car the drum, with one end of the spring attached to it, rotates and winds up the spring until the dogs D<sub>2</sub> and B<sub>2</sub> come into contact with one another, when the whole device, being solid, transmits the power in the usual way. The spring having thus been wound up, is retained in this condition by the pawl and ratchet B<sub>3</sub> and A<sub>3</sub>. To start the engine a pedal slides the ratchet ring until it engages with the pawl and also causes the dogs C<sub>1</sub> and A<sub>2</sub> to disengage.

The spring is then free to unwind and rotate the clutch shaft through the medium of the ratchet and pawl B<sub>3</sub> and A<sub>3</sub>. The pedal being released, the ratchet slides back to its normal position and the spring is again wound up as described above. Some tests were carried out under the control of the Royal Automobile Club, which were satisfactory while the motor was warm, but which failed when an attempt was made to start the motor when it was cold after standing all night.

This may have been due to the make of car, which had automatic intake valves and battery ignition. When the engine was warm it was found that the pull of the contrivance was sufficient to cause the engine to make three complete revolutions.

**TO FLY OR NOT TO FLY: THAT'S THE RUB**—Intermediate forms have wiped out the sharp distinction between monoplanes and biplanes, and the world is returning to its first classification of flying machines—those which fly and those which don't.—*Pierre Maillard.*

**MOTORPHOBIA OR PHILANTHROPY**—Switzerland, accused of motorphobia in her somewhat radical road regulations, retorts that it is not motors but motorists she loves less and the plain humans she loves more.

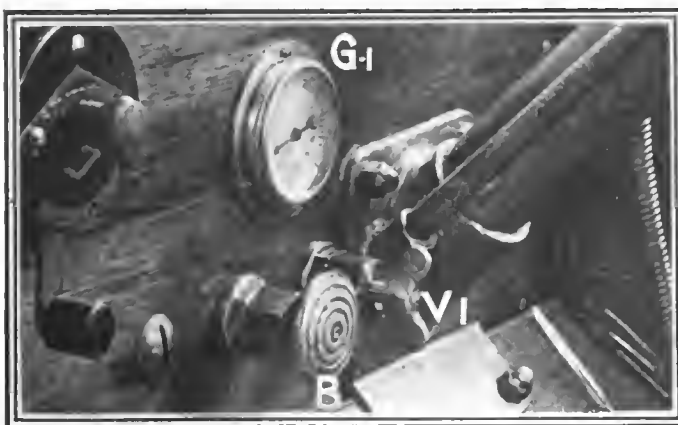

Fig. 2—Dashboard of the Everitt car, showing the disposition of control mechanism

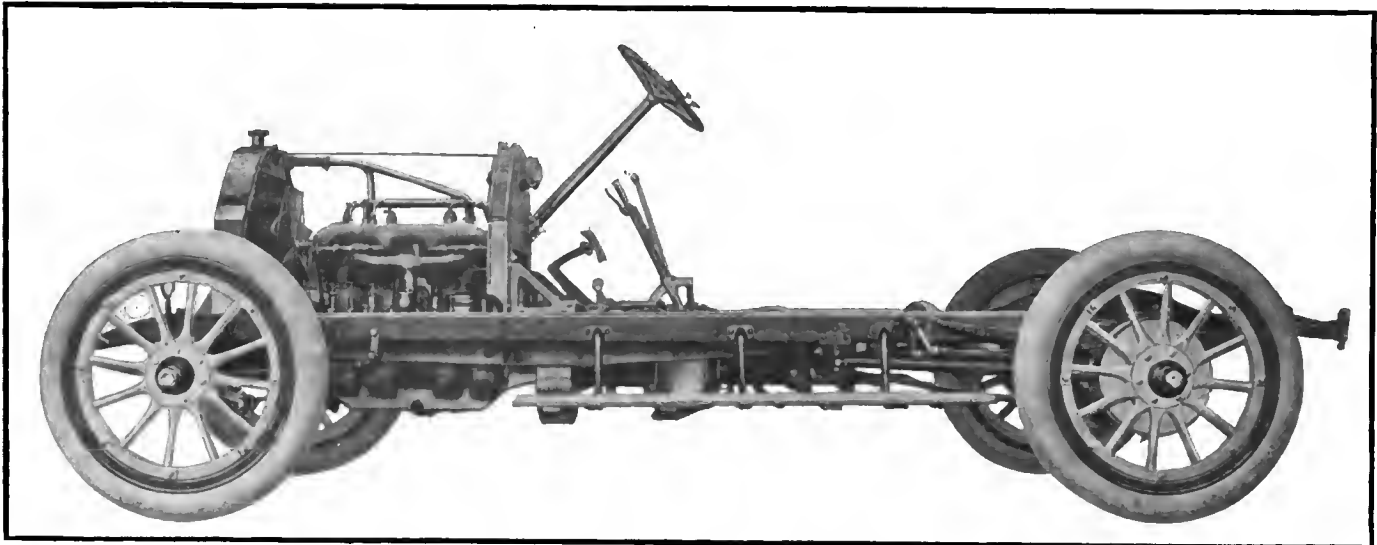

Fig. 1—The standard chassis of the Speedwell line, used with all types of cars

## Specifications of the Speedwell

**T**HE chassis used in connection with the 1912 output of the Speedwell Motor Car Company, of Dayton, Ohio, will be fitted with twelve different styles of body. The same chassis is used throughout and is equipped with a standard power plant.

The Speedwell motor is a four-cylinder four-cycle product, with the cylinders cast in pairs. The castings are of the L-head type, the valves all being on the left-hand side of the motor and the exhaust and inlet manifolds M and N, Fig. 8, being placed one above the other. The lower manifold N is the inlet. The manifolds are held in place by means of dogs and stud bolts. The waterjackets are cast integrally with the cylinders, but are fitted with removable heads to allow of inspection and cleaning.

The pistons are of gray iron finished from the casting by grinding to a fit and equipped with four piston rings which are hand finished to insure accuracy. This process of manufacture is a longer one than by turning the rings out entirely by machinery, but there is a gain in the fitting of the part when made in this manner.

The valves are interchangeable throughout the motor and are all directly operated off the same camshaft. The valve tappet guides G extend a liberal distance above the crankcase and are detachable by removing the nuts, which are screwed directly into the top of the crankcase. Above the valve tappet guides are the

valve rod adjustment nuts, by means of which the valves may be kept properly timed after they are ground or otherwise adjusted. Above the adjusting nuts are the spring seats upon which rest the valve coil springs S. The camshaft is driven through a set of gears at the front end of the motor, the drive passing through an intermediary wheel N, Fig. 6, before being transmitted to the camshaft gear wheel T. This intermediary wheel is the same size as the camshaft wheel, being twice the size of the gear L on the end of the crankshaft.

The remaining wheel O in the timing gearcase is of the same size as the gear on the end of the cranks and actuates the shaft which drives both the magneto M, Fig. 7, and water pump P. This shaft runs along the right-hand side of the motor and drives the fan pulley just after passing through the end bearing of the shaft. Just behind the fan pulley there is a coupling; the shaft then passes to the water pump and fan. The lengths of shaft adjoining the magneto and pump are removable so that either of these parts may be taken out independently of the other, this being effected by means of adjustable companion flanges. The gears which drive these shafts are all of helical cut, a feature which tends to avoid noise.

The crankcase is a two-piece casting of nickel-aluminum alloy, the upper half being entirely separate from the lower. The two cylinder blocks are fastened to the crankcase by means of heavy

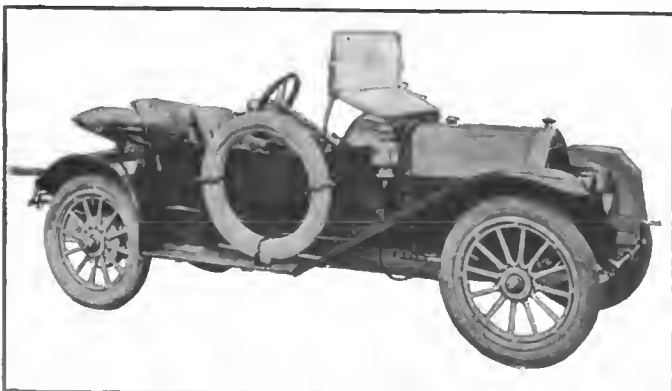

Fig. 2—Showing the Speedwell three-passenger "duckboat"

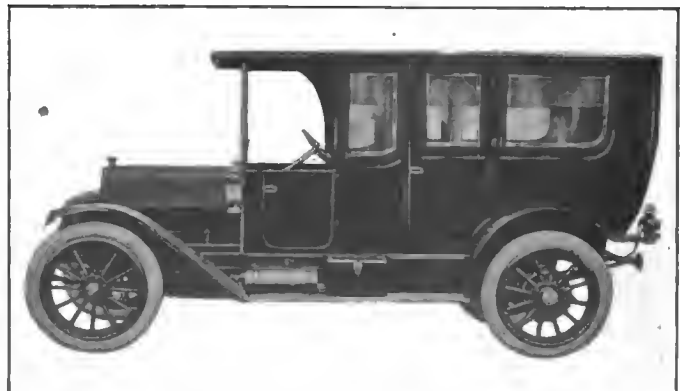

Fig. 3—The Speedwell seven-passenger limousine

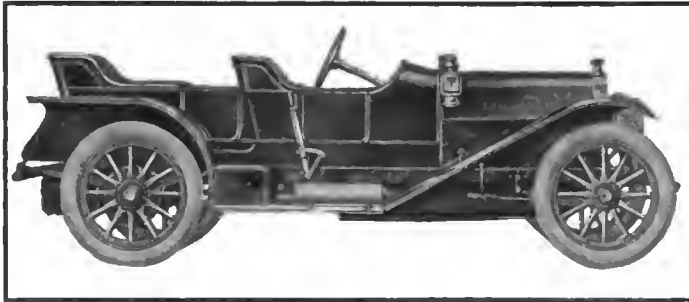

Fig. 4—Showing the Speedwell demi-tonneau

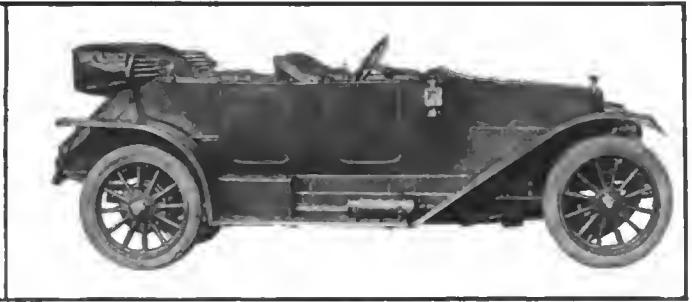

Fig. 5—Speedwell "cruiser," which sells for \$3,500

holding down bolts which pass through a broad flange on the base of the cylinder castings and through the crankcase. The casting is so formed that a seating is furnished for each of the valve tappet guide nuts mentioned above, the timing gear casing being also a part of the casting. The cover of the gear housing is removable so that easy inspection of the timing gears is afforded. The motor supporting hangers are cast with the upper part of the crankcase so that the lower half may be dropped entirely by merely removing the bolts which support it and by this means access may be had to the cylinders, pistons, camshafts, crankshaft, connecting rods and wrist-pin bearings.

The crankshaft is of heat-treated alloy steel and is supported upon three plain bearings of good length. The bearings are lined with double white bronze bushings and are located at the ends of the crankshaft and between the two pairs of cylinders. In balancing the crankshaft, the flywheel is bolted thereto and then weighed upon a special instrument made for the purpose.

The lubrication of the motor is effected by means of the splash system. The oil is carried in the lower part of the crankcase, which is divided in such a manner that it consists of two parts. The division is made by a horizontal partition which is placed in the lower half of the crankcase and forms the basis for the troughs used in the splash system as well as the top wall of the oil reservoir. The oil is carried beneath the horizontal partition in the lower half of the crankcase, which has a capacity of about 2 gallons. The oil is

supplied to the crankcase reservoir by means of a filler hole F, Fig. 7, on the side of the crankcase. This filler hole is provided with a cap which, when removed, discloses a screen through which the oil is poured when filling the crankcase. The height of the oil in the reservoir is determined by means of a float level gauge on the same side of the motor as the filler hole so that in filling it is not necessary to spill oil on the exterior of the motor, for by watching the gauge it is easy to determine the amount of oil in the crankcase. A gear driven oil pump takes the oil from the base reservoir and leads it to a sight feed which is located on the dash in easy view of the driver. All the oil which passes through the lubricating system of the motor must pass through this sight feed, so that the driver has always an accurate knowledge of the condition of the oil in the motor.

After leaving the sight feed the oil is led to the crankcase through a distributing pipe. The distributing pipe leads to the splash troughs in the upper part of the base casting of the motor.

The motor is cooled by water which is forced through the jackets by a centrifugal pump mounted as described above. The jackets are made of good width and thus aid in an easy circulation. The water intake manifold is on the right-hand side of the motor, the water outlet being at the top of the cylinder castings. The latter consists of a siamesed pipe which runs from the top of the cylinder waterjackets to the top of the radiator, the junction of the two pipes taking place at a point just

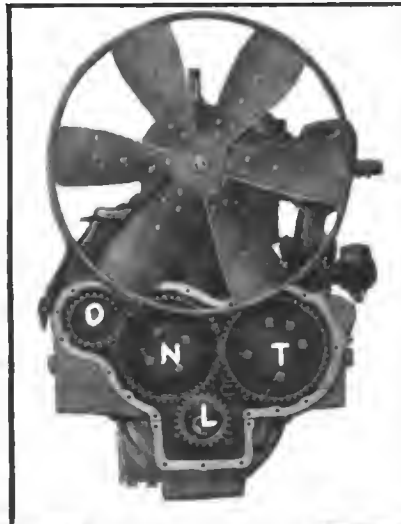

Fig. 6—End view of motor, showing timing gears and fan

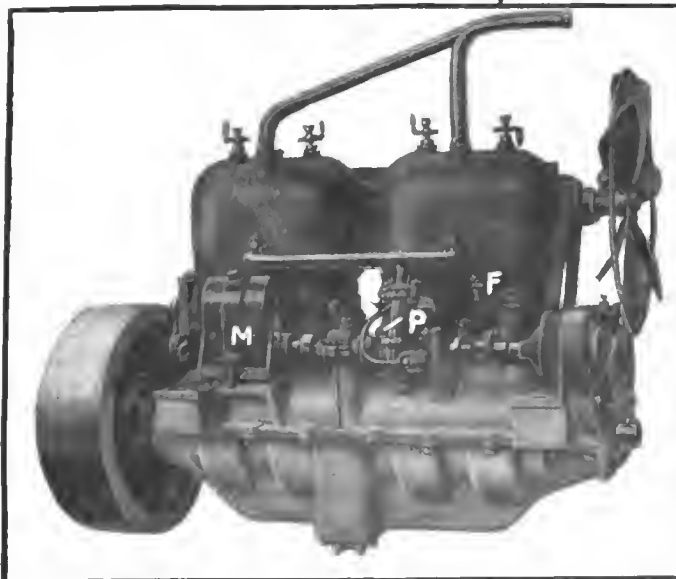

Fig. 7—Magneto side of Speedwell motor

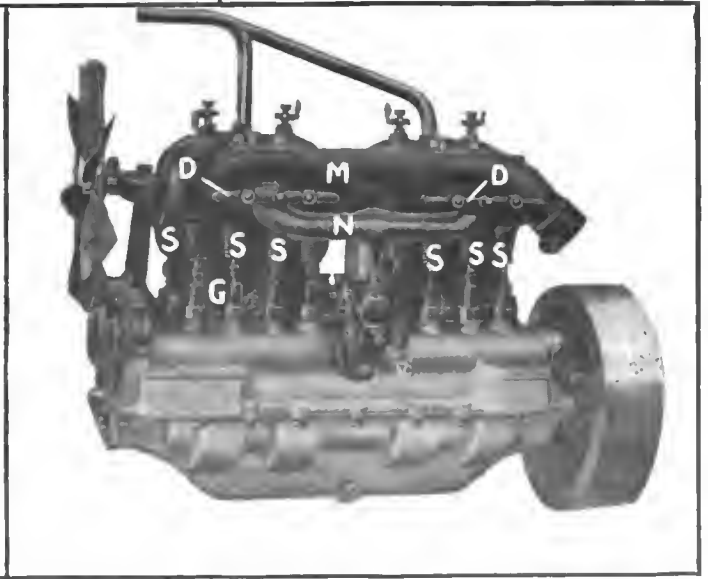

Fig. 8—Showing manifolds and valve actions of the motor

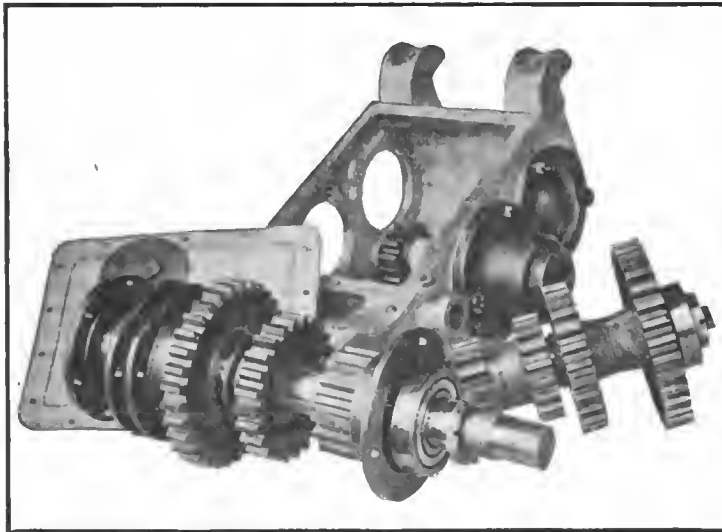

Fig. 9—Disassembly of the gearset

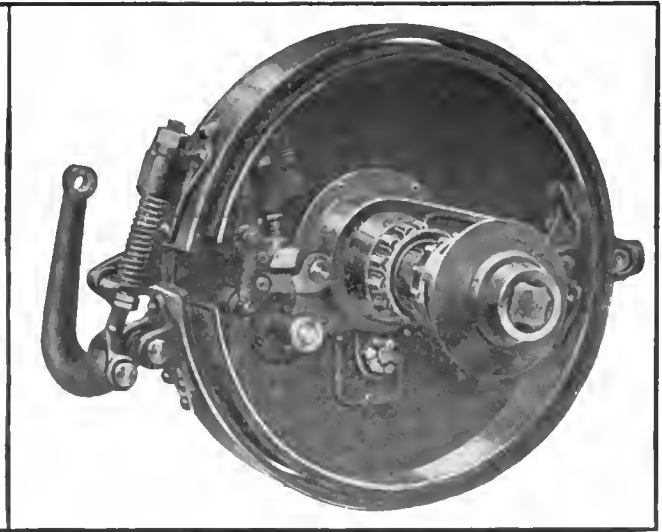

Fig. 10—Showing the brake mechanism

above the center of the foremost pair of cylinders. The radiator is of the Speedwell type and is of cellular construction. A feature of the radiator is that the cells are of square section and that the water circulates in all four sides of each cell. The radiator is cooled by a six-blade fan which is driven by a belt off a pulley located on the pump and magneto shaft. The belt is adjustable so that any stretch may be readily taken up.

The carbureter is hot-water jacketed and is held suspended from the T-shaped inlet manifold. The throttle is augmented by an adjustable cam which controls the opening through which the gasoline passes into the mixing chamber. When the throttle is opened this passage is enlarged. The auxiliary air valve is entirely automatic.

Ignition is accomplished by means of the Bosch dual system. The high-tension magneto is located as has been described. The magneto furnishes the running current while the battery set, which is also provided, furnishes the current for starting the motor. One coil and a single set of spark plugs are employed

for both systems. The coil is of the non-vibrating type and is set in the dash so that it is readily accessible from the driver's seat. The appearance presented by the coil is merely that of a circle of 4 inches in diameter. A self-starting button and kick-over switch are fitted on the dash. The timer is not required for this system since it is an integral part of the magneto.

The clutch is of the leather-faced cone type, fitted with a spring engagement so as to insure an easy take-up in starting. The clutch is provided with a ball thrust which is contained in a dust-tight housing. As soon as the clutch is disengaged a clutch brake stops it from rotating. This will tend to produce silence in the changing of gears. The clutch is held to its work by means of a heavy spring which is released through the action of a yoke which in turn acts on a ball thrust ring. A universal joint is provided between the clutch and the gearset so as to provide for any disalignment due to inequalities in the road or other causes. The universal joint and thrust bearing are both enclosed and packed tightly in grease to keep them well lubricated.

The gearset is mounted on a sub-frame in the center of the chassis and is accessible for adjustment or lubrication by means of a removable cover which can be detached by removing the floor board above it. One of the changes incorporated in the new models is in the gearset, as the size of the gears has been increased and the shafts have been made heavier. The shafts are of nickel steel heat treated, while the gears are of vanadium. The shafts are mounted on annular bearings which are capable of considerable wear before a change in adjustment is necessary. The change gear arrangement provides for three forward and one reverse speeds, the changes being made by means of a hand lever in the usual H-slotted quadrant. By this method the selective type of gearing is used; that is, any desired change may be made without passing through the other speeds. The gearset shafting runs in oil and is closed by means of stuffing boxes which prevent a leakage of the lubricant.

The propeller shaft is provided with universal joints at either end which take up the differences in alignment. The shaft is forged directly with the cross-pieces of the universal joints so that the

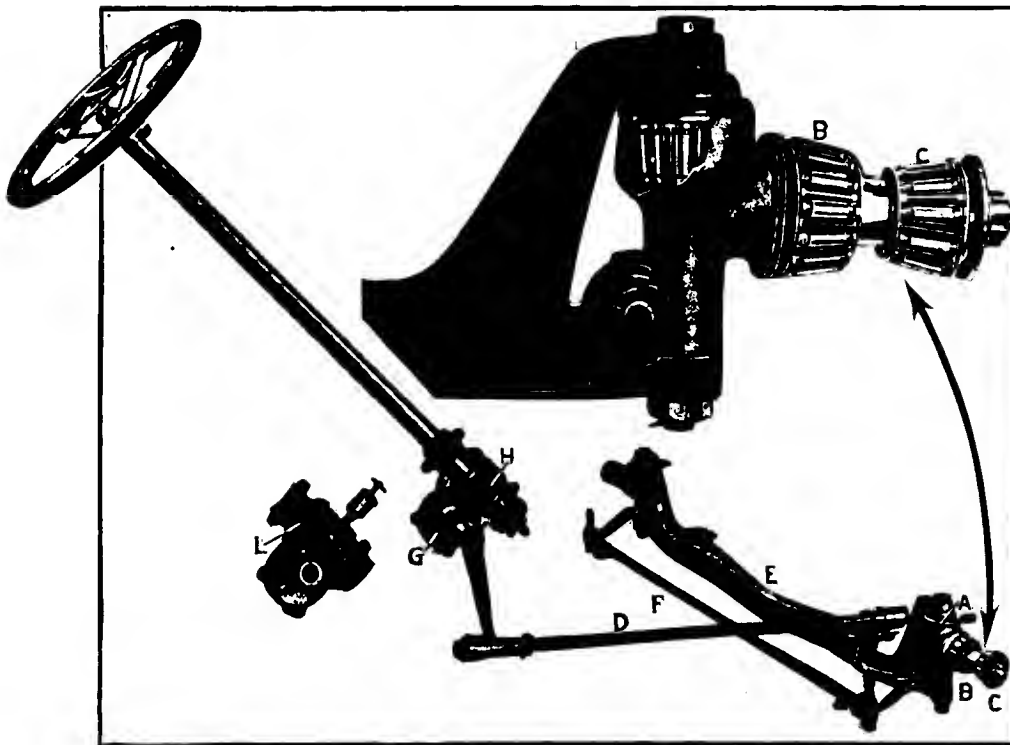

Fig. 11—View of front axle and steering gear with an enlargement of the knuckle



whole integral piece can be given the same degree of heat treatment. An object in the design of the chassis that is worth mention is that when the car is carrying passengers the springs will be deflected to just such a degree that the drive will be very nearly a straight line. This will save a loss in the driving efficiency. The universal joints on the propeller shaft are enclosed in greas-tight casings which protect them very effectively against any accidental derangement.

The rear axle is of the floating type, the casing containing the differential and live axle being all in one piece, with an inspection cover bolted over the differential. The differential, large and small bevel gears and their bearings may be lifted directly out of the axle housing if it is desired without disturbing any adjustments. All moving parts of the differential and rear axle run on Timken roller bearings. Strut rods are fitted on the axle and are fastened to the frame by ball joints to relieve the frame of driving shocks, while the torque strains are taken up by a torque rod which is suspended between the spring buffers.

The front axle is a drop forging of I-section, the spring seats being forged integrally with the rest of the axle. The front axle E and steering gear are shown in Fig. 11. The steering pivot works on a Timken roller bearing A, which is made large enough to carry the weight of the car. This bearing is shown enlarged in the illustration, as are also the two wheel bearings B and C. The connecting rod F between the two wheels is placed behind the rear axle and the reach rod D which connects the front wheels to the steering gear is placed above the axle.

The steering is effected by an irreversible worm and gear G of vanadium steel which is enclosed in a tubular casing L. Jars and strains are removed from the steering gear by cushion springs which are fitted in the reach rod. The steering wheel is 18 inches in diameter, being of Circassian walnut with an alu-

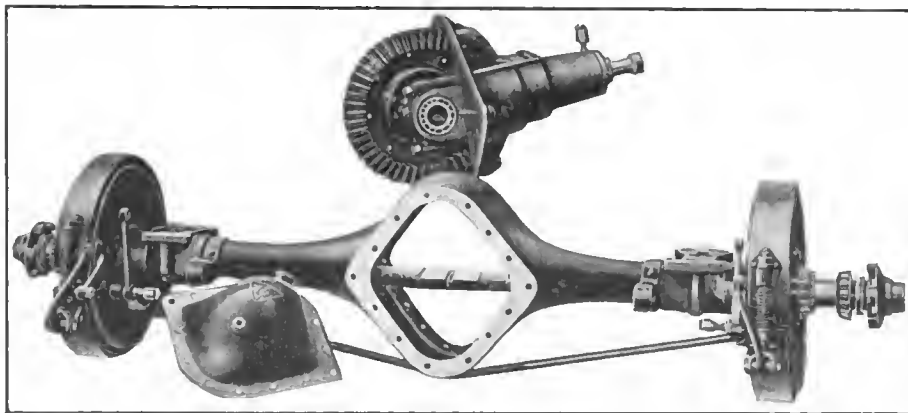

Fig. 12—Rear axle with differential removed. Note squared ends of live axles

minum center. The spark and throttle levers are mounted above the wheel.

Motor and transmission are supported by a subframe which is hot riveted to the main frame and stiffened by means of gusset plates. The springs are semi-elliptic front and rear, being 2 1-4 inches wide and 40 inches long in front and 56 inches in rear.

The wheels are of the artillery type and fitted with Firestone Q. D. rims, except that in the Model H roadster Goodyear rims are substituted. All five-passenger models are fitted with 36 x 4-inch tires, while the seven-passenger models have 36 x 4 1-2-inch tires. The rear wheels are equipped with foot and hand brakes, as shown in Fig. 10. The service or foot brakes and the hand emergency brakes are each furnished with equalizers and are of the expanding and contracting types.

The bodies provided with the standard chassis, are of twelve types and consist of a semi-racer roadster, an open-pony tonneau, five-passenger touring car, close-coupled five-passenger car, four-passenger torpedo, four-passenger semi-racer, three-passenger duck boat, fore-door five-passenger touring car, seven-passenger touring car, seven-passenger limousine and a four-passenger cruiser.

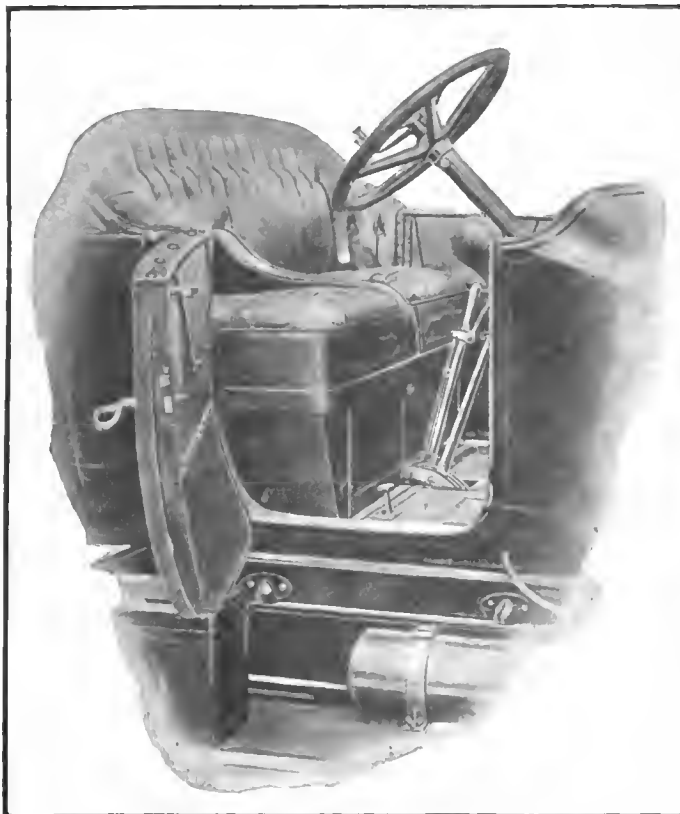

Fig. 13—Showing method of control in fore-door bodies



Fig. 14—Interior of the Speedwell Limousine body

## Digest of the Leading Foreign Papers

DEFECTS IN CASEHARDENING WORK are attributable either to the process of cementation or to that of hardening. Those due to errors in the cementation may be (1) deformations, (2) failure to cement, (3) cementing where none is wanted, (4) irregularity of penetration, (5) excess of carbon percentage in the cemented shell, which causes accidents in the hardening, and (6) spots in the metal. The defects which the hardening process may produce are (1) deformations, (2) irregularities in hardness, (3) cracks and (4) spots.

Defects which may be due to other causes or which are not developed until the casehardening piece is taken into use are (1) partial or complete lack of hardness, (2) brittleness of the core, (3) brittleness of the shell (the same breaking off), (4) rupture of the shell and (5) deformations which are developed during use.

Deformations in cementing may be due to placing the piece in its box in such a position that its own weight will bend it when hot. More frequently it is due to twisted grain or fibre of the metal (*écrouissage*). The piece is usually made from rolled or drawn stock or it has been pressed or stamped and its molecular structure is more or less upset or misshapen. To avoid this trouble the stock, before it is machined, should be brought to a uniform heat 50 degrees higher than the critical temperature (which is about 900 degrees centigrade for soft casehardening stock), and should be allowed to cool slowly, especially if the steel is rich in nickel (5 per cent. to 6 per cent.), as otherwise martensite is likely to form, rendering the stock hard to work. At all events the hardening department should not accept deformed pieces, since it is relatively easy to redress pieces which have only been cemented. After all, however, a deformation which has been removed may reappear in the heat before quenching.

Failure to cement is rare and always due to poor workmanship. As has been proved, all steels except gamma steels (of high nickel and manganese) harden by cementation followed by bath.

Both failure to cement and failure to protect certain portions against cementation are discovered only after the quenching, by filing (or the scleroscope).

Irregularities in penetration come from poor distribution and packing of the cementation powder or compound, or from lack of uniformity in the fire. Irregularity in the carbon content of an otherwise equable shell is due to too high or too low heat, to wrong timing of the heat or to a poor cementation compound; rarely to an excess of silicon in the steel.

Too high carbon content in the outer shell is much to be feared. A cement too active, excessive temperature or prolonged exposure to the heat are the causes, and steels of medium carbon are more subject to this trouble than mild steels.

Spots in the metal are usually due to a silicious filler-earth or to a wet cementing compound.

No sure remedy has been devised against deformations resulting from the quenching, though Breshaw has shown that in the case of certain high-carbon steels a double heating reduces the deformation. Irregularity in the hardness, whether it is shown in each piece or by comparison among several pieces which should be of the same hardness, may be due to faults in cementation or to quenching at a wrong temperature (750 degrees C. is right), but it may also be due to loss of carbon in the heating before the bath, and the latter is the more frequent cause. If the atmosphere is oxidizing, which is the rule in furnaces heated by direct coal fire and common in gas furnaces, though perhaps only caused by the repeated opening of the furnace door, a decarbonization takes place which easily penetrates

1-10 mm. to 1-5 mm. into the shell and is sufficient to reduce the hardness of the finished piece greatly. Cracks in casehardened pieces are seldom due to the treatment, but usually may be traced to flaws in the billets. Spots appearing after the quenching are due to exposure to oxidation.—From treatise on casehardening by Léon Guillet in *Le Génie Civil*, July 29 and August 5.

Laboratory and shop inspection of case-hardening work should be distinct and separate. Only the largest establishments can have a laboratory personnel whose function it is to supervise the reception of raw material or to check off materials at the steel works and afterwards verify the partial shipments. Where there is a laboratory force, it should take a certain number of samples from a lot of casehardened pieces and should try them by chemical analysis, especially for carbon content in the shell, and this content should not exceed 1.2 per cent. Further, a micrographic examination should show martensite at the center of the hardened piece, and even finely divided pearlite if the piece has been subjected to the double quenching process, but martensite and ferrite if it has been quenched at 750 degrees only. In large pieces some osmondite should appear. The shell should always be formed of very fine martensite without cementite. Examination of an annealed piece also gives valuable information, showing the thickness and regularity of the cemented layer and the carbon content at the surface, but it must be remembered that, during this annealing, carbon migrates from the periphery toward the center, lowering the carbon content at the surface.

The laboratory force should also look into the matter of possible brittleness of the core. In the majority of shops results are judged by filing with regard to hardness and from the grain of a fracture with regard to brittleness. But these tests are rudimentary and cannot be connected in figures. The grain gives occasion for most erroneous inferences. The result depends mostly upon the method used for producing the fracture and upon the thickness of the piece. As the author has shown (and illustrations are presented of the fractured pieces), the same casehardened bar fractured in several places a few centimeters apart shows a fine grain and a fibrous core wherever it has been broken by many light blows, but a very coarse grain where it has been broken by one severe blow. No importance should be attached to coarseness of grain, unless fractures are produced in a perfectly constant and predetermined fashion and unless it is very well known what kind of fracture each kind of piece should produce under these circumstances. In reality there is only one method for testing brittleness, which is by the notched bar and impact test, as prescribed in the main features by the congress of Copenhagen (1910), and the details of this method are in need of further precisioning. (The author here seems to take distance from those scientists who hold that the relations between tensile strength and the resistance to crushing, in test pieces of prescribed dimensions, always give an exact measure of brittleness).

The methods of shop inspection and control are of wider application and, therefore, perhaps of greater importance than those to be practiced at the laboratory. (1) All pieces arriving at the shop for treatment should be tried for hardness with reference to its uniformity. To this end the Brinell rating should be determined by a steel ball pressure apparatus which should be suitable for receiving pieces of greatly varying size and shape. One of the new Cail apparatus serves the purpose, or else another model which is used at the Derihon factories at Loucin-les-Liège and which the author has reproduced at the Dion-Bouton factories. It consists in a lever carrying the steel ball at one point and a weight at the end of the lever. All

pieces intended for treatment should, in the author's opinion, be passed under this apparatus, and one workman can perform this at a shop turning out 250 to 300 casehardened pieces per day. (2) The shop inspection of the cementation process is best served by placing a test piece of the same steel which is used for the work at some certain point of each box—preferably at the middle of it—and breaking this piece after quenching it at 750 degrees. After some experience this will give an approximate idea of the thickness of the shell in other pieces. (3) Shop inspection of hardness after quenching. Until recently it has not been possible to measure hardness. By filing it was only estimated, and the Martens sclerometer is only a laboratory instrument. In practice the scleroscope is now of the greatest utility in casehardening shops, as Portevin and Berjot have shown in *Revue de Métallurgie* for January, 1910. The height to which a steel ball, or rather a little hammer with a diamond point, rebounds from the hardened piece when allowed to drop from the top of scleroscope furnishes a practical means for actually measuring hardness in all its degrees, even if the rebound is to some extent a function of the mass of the test piece.

In brief, shop inspection of casehardening work involves the purchase of one Birnell apparatus and one scleroscope, which is not a highly expensive equipment, while the results are of the highest interest for securing the uniformity of work.—From treatise on casehardening by Léon Guillet in *Le Génie Civil*, July 29 and August 5.

A USEFUL ADDITION TO THE AUTOMOBILIST'S TOOL-BOX—It is sometimes difficult to find a couple of stones of suitable size to chock under the wheels, when a car is left standing at the side of a steep road, and the brake adjustment is not always right for locking the wheels when the driver's foot or hand is not on the pedal or lever. With this difficulty in mind a motorist tells of an arrangement he has made. He has in his tool

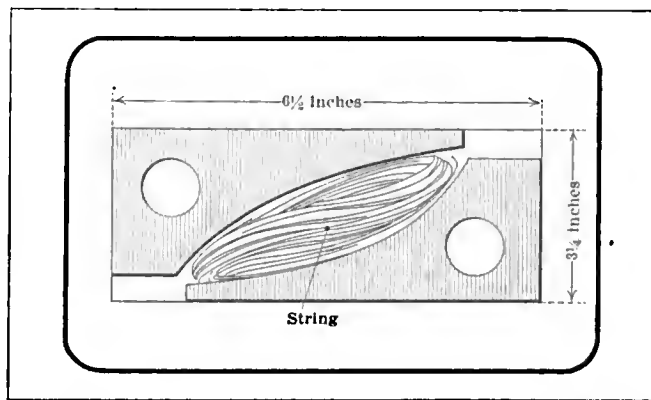

Handy tool-box adjunct—chocks to lock the wheels, and how to carry them

box two chocks or wedges made of pine wood and packed as shown in the illustration, a large skein of tarred string or cord acting as wedge to press the chocks against the sides of a little kit in which they are kept, thus preventing all rattling. And the string comes very handy for bandaging a sick tire or for wrapping any kind of a package. The two holes in the chocks make it easier to take the contents out of the kit, and also may serve as receptacles for two little rolls of adhesive tape.—*Automobile-Aviation*, September 14.

OKNOF, of the metallurgical laboratory at the Polytechnical Institute of St. Petersburg, details a series of experiments, accompanied with large micrographic plates, in which he comes to the result, among others, that, 1, pearlite consists of curved lamellæ of cementite imbedded in the mass of ferrite, and, 2, martensite consists of straight, flat, but not needleshaped, crystals.—*Métallurgie* (Halle a. d. Saale), Sept. 8.

## Harking Back a Decade

TEN years ago this week *The Motor Review* contained notice of the following happenings:

A 9-horsepower Gasmobile, driven by William Walters and carrying Eddie Bald and Sam Brock, broke the record for the run between Buffalo and Niagara Falls by 2 minutes. The car made the distance in 38 minutes, some of the miles being turned in 1:30.

W. C. Janes has purchased the Buffalo branch of the Locomobile.

The capital stock of the newly formed Stearns Automobile Company has been offered to the public at Syracuse, N. Y. The common issue was offered at \$5.25 a share, par value \$25.

The automobile trade of Philadelphia has formed a permanent organization. The first act of the association was to postpone the show dates until early in 1902.

At Pittsburgh, for the first time, automobiles formed a feature of the industrial displays at the annual exposition.

Floor plans of the Chicago Coliseum, arranged for the show next March, indicate that the demonstrating track around the exhibits will be used again. This feature has been dropped from the New York shows.

Rumors are again in circulation of a merger of the tire-making interests at Akron. August Belmont and Charles R. Flint, who were active in forming the United States Steel Corporation, are said to be engineering the plan.

If some of the many thousands of good mechanics who are struggling to manufacture complete cars would turn their attention to the operation of storage and repair stations the automobile field would be cleared of many so-called manufacturers who are really only experimenters.—Editorial.

Three out of twenty cars that started in the Chicago-Buffalo tour reached the goal. The difficulty in touring is not to make the cars go over the road, but to make them go together. Pleasure on the move is hard to gain for a number of people collectively. The fact that only three cars finished is a reflection neither upon the cars nor the drivers.—Editorial.

A pneumatic self-starter for automobiles is the leading patent treated this week. Auxiliary valve gearing to supply compressed air is the feature. After starting it is necessary to shift the valve gear to supply the gasoline mixture. Patent No. 683,459.

The Shelby Steel Tube Company, of Greenville, O., announces that it will enlarge its plant materially. It is the intention of the company to become the largest seamless, cold-drawn tube plant in the country. A billet-piercing plant is to be installed by the company.

Pittsburgh police have taken a sharp interest in the speed limit recently. The legal rate is 12 miles an hour. Last Tuesday a well-known chauffeur was halted by an officer but he proved such a convincing talker that he was soon allowed to steam away.

The Stearns Steam Carriage Company will send seven types of carriages to be exhibited at the Boston show this Fall. The cars are all of 1902 model.

Six Locomobiles will act in place of horses as conveyances for the Grand Marshal and his aides at the forthcoming bi-centennial parade at Yale.

The race meeting of the Rhode Island Automobile Club will be held at Providence, October 17, 1901, and there are a large number of entries in the various events.

# Letters Answered and Discussed

## Concerning Engine Design

Editor THE AUTOMOBILE:

[2,862]—I would greatly appreciate it if you would give some information regarding gasoline engine design.

1. What should be the length of the piston used in connection with an engine having a bore of 4 inches?

2. What should be the diameter of the piston pin and what is the best location for it? How should it be fastened to prevent endwise movement?

3. How is the side-thrust on the cylinder walls calculated?

New York City. ADOLPH KLINE.

Referring to the sketch, Fig. 1, the dimensions of the various parts of the piston will be seen. The bearing surface of the piston for an engine of 4-inch bore should be about 4 1-8 inches in length. The wrist-pin may be located very nearly at the center of the piston or it may be located at the exact center and should be fastened by a set bolt and lock nut as shown. The set bolt may be a 3-8-inch bolt. The position of the piston rings is arbitrary to a great extent and the dimensions as given in the illustration need not be rigidly adhered to.

The side thrust on the cylinder walls is calculated by taking the thrust on the top of the piston and multiplying it by the tangent of the angle which the connecting rod makes with the axis of the cylinder. Since the tangent of this angle is a maximum when the crank makes an angle of 90 degrees with the cylinder axis the side thrust will be about a maximum at this

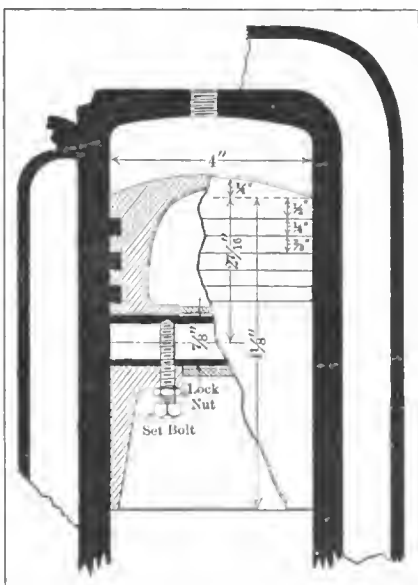

Fig. 1—Showing a section through a piston for a motor of 4 inches bore

The Editor invites subscribers to communicate their automobile troubles and personal experiences, stating them clearly on one side of the paper. If the nature of the case permits, send a sketch, even if it be rough, in order to assist to a clearer understanding. Each communication will receive attention in the order of its receipt, if the writer's signature and address accompany it as an evidence of good faith. If the writer objects to the publication of his name, he may add a nom de plume.



## My Best Repair

Temporary automobile repairs made by the driver or owner while on the road and permanent repairs made in the garage after the run is over, are interesting to all automobile owners.

Every driver at one time or another gets up against it. Something breaks or gets out of order on the road—a stop has to be made and some repair effected.

It may be a spring leaf has broken; a shackle bolt or strap may break; a steering tie rod is bent; the car skids into a curb and bends a steering arm or the starting crank; a throttle or magneto connection breaks owing to vibration; a radiator leak is started by a stone or some other means; a leak in the gasoline tank is discovered; there is a small hole in the gasoline feed line; a brake facing may burn out; a brake connection breaks; a front axle gets slightly sprung; a clutch starts slipping, or any one of a thousand things may happen.

Every automobile owner is interested in knowing how repairs have been made, how long it took to make them, how much they cost, and by whom they were made. All this information broadens the knowledge of the automobile owner and so helps the industry.

Thousands of car owners who are readers of THE AUTOMOBILE, have had experiences of this nature and have made a temporary roadside repair—a permanent cure at the garage. We want you to write in simple language in a letter what repair of this nature you have had to make, how you made it, how long it took you and how much it cost.

You can make with your lead pencil one or two rough sketches indicating the broken or damaged part and showing how the repair was made.

We are going to publish these repair letters from week to week in these columns. Every reader should send in one experience or repair and how accomplished.

Some have experiences with short circuits, adjusting carbureters, motor knocks, hard starting, noisy timing gears, etc. Information on how these were discovered or rectified are equally interesting.

The experience of each reader is interesting to every other reader. To you, some of your repairs or experiences may be commonplace, but to owners of automobiles with less experience they are most interesting.

Analyze your past experiences and send in one or two of them.

Give your name and address, legibly written. If you do not want your name to appear, make use of a nom de plume.

Editor THE AUTOMOBILE.

point. Since the tangent of the angle used in the calculation is, at this point, the length of crank divided by the connecting rod, the calculation is simply one of multiplying the thrust upon the top of the piston by this fraction. At this point the thrust will not exceed 300 pounds which may be taken for a safe calculation. Taking an example to make the process perfectly clear, a connecting rod 12 inches in length may be assumed, and the crank which will equal one-half the stroke may be taken as 2 1-2 inches. The side thrust will

then equal  $\frac{300 \times 2 \frac{1}{2}}{12} = 62 \frac{1}{2}$  pounds. The explosion pressure is all that has to be

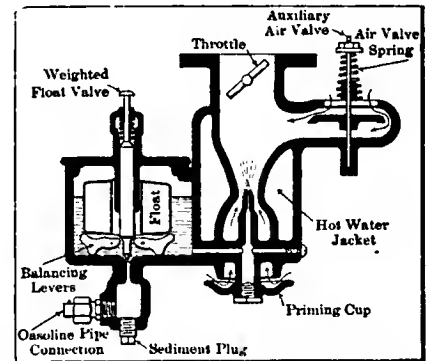

Fig. 2—Section through carbureter with eccentric float

reckoned with in designing the combustion space.

## Wants Points of Adjustment

Editor THE AUTOMOBILE:

[2,863]—I followed with great interest your directions as to the manner of adjusting the carbureter. I wish you would point out the positions of the various fixtures for adjusting the gasoline, air, etc., on different types of carbureters.

Plattsburgh, N. Y. AMATEUR.

The adjusting devices on all the carbureters are on the same principle and by the illustration of two of the common types it would be a simple matter to perform the adjustments on any and to locate the points of adjustment. Fig. 2 shows a type of carbureter in which the float is not concentric with the spray nozzle, while Fig. 3 shows a carbureter with the spray nozzle and float concentric. In the latter illustration the needle valve is adjusted at A, the auxiliary air valve at C, by either increasing or decreasing the tension on the spring B. The gasoline inlet is regulated at D, the main air valve at E and the drain cock is located

at F. By a comparison with the type depicted in Fig. 2 it is seen that the principles of adjustment are the same.

### One Cylinder Dead

Editor THE AUTOMOBILE:

[2,864]—Since you have a page of your magazine devoted to the troubles of your subscribers I am going to take advantage of that fact and ask you to help me out of my trouble.

I have a car which is equipped with a four-cylinder motor. In one of the four cylinders I can get no explosion, and after having run the engine for a time the cylinder which does not fire contains quite an amount of oil. The electrical plant seems to be all right, including battery, wiring, magneto and spark plugs.

I have to prime the motor before it will start and, after priming it have to turn it over several times before getting an explosion. On the first explosion the engine will backfire and then will run all right except that the one cylinder will be dead.

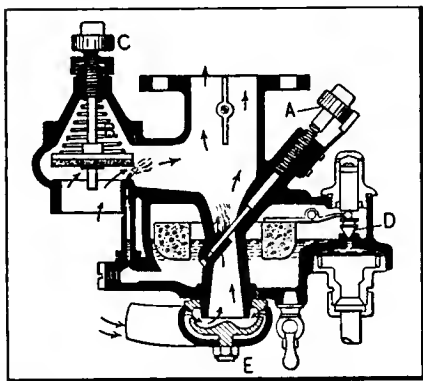

Fig. 3—Section through carburetor with concentric float

Would you kindly let me know what could be the matter?

M. W. VAN AMBER.

Castorland, N. Y.

Since the other cylinders fire without trouble after the engine is started the trouble will be of such a nature that it is confined to the one cylinder. This eliminates carburetor and magneto adjustments. The only parts of the ignition system which could affect but one cylinder are the spark plugs and the timer; the spark plugs may be eliminated by taking a plug out of one of the cylinders that does fire and trying it in the dead cylinder. The timer may form a perfect connection with all but the point which corresponds to the defective cylinder. Examine the contact points to determine if they are clean or whether the rotor shaft is eccentric and hence misses one of the points altogether. This will eliminate the ignition system.

The search should then turn to the valves. Try the compression of the defective cylinder and notice whether it is leaky. If so,

the trouble will be found to be in a pitted, cracked or very dirty valve. If dirt lodges beneath the exhaust valve it will prevent its closing. If the compression is leaky and the valves are in perfect condition the fault lies in a cracked cylinder or in some other cause of leakage between the cylinder wall and jacket. A new cylinder will be required in this case or perhaps the damage may be repaired by some welding process.

The backfiring in starting the motor is due very likely to the fact that when you prime the motor you give it too much gasoline, unless the compression is leaky in these cylinders too which might be the primary cause of the trouble. It is very natural that the dead cylinder would accumulate a quantity of lubricating oil after the motor has been run for a length of time, as it will work its way up from the crankcase.

### Wants More Power

Editor THE AUTOMOBILE:

[2,865]—I have a car which I have changed from a touring car to a runabout, the engine having a bore of 3 inches and a stroke of 5 1-2 inches. The exhaust valves are on the left-hand side of the motor and the inlet valves are overhead. The driving gear ratio is 2-2-3 to 1 with 36-inch wheels. Can you suggest a way to get more speed out of the engine?

If I advance my valve timing do I have to have different shaped cams? I am told that I would have to get cams made which would hold the valves open longer. The engine has all the power I need but will not turn over more than 1,300 revolutions per minute.

D. B. BLAISDELL.

New York City.

The timing diagram illustrated in these columns in the issue of July 20 will give a valve timing which should give the engine a maximum flexibility. If the cams fitted now are not of correct shape to hold the valves open for the period required they will have to be changed for new ones. The exhaust valves are held open for 225 degrees of the crank circle while the inlet valves are held open during a period of 200 degrees.

At 1,300 revolutions per minute the maximum speed attainable with the gear ratio specified would be 52 miles an hour which should be improved by a better timing of the valves.

### Has Carburetor Troubles

Editor THE AUTOMOBILE:

[2,866]—After going through a period of tinkering and experimenting on my carburetor I at last conceived the idea of appealing to THE AUTOMOBILE for advice. I intend buying a good carburetor and before purchasing wish to become acquainted with the following points:

1. What are the requirements of an ideal carburetor?
2. Is there a carburetor which offers but a negligible resistance to the ingoing air no matter whether the engine is going fast or slow?
3. Does the increased resistance of the air decrease the power of the engine? I find that if the carburetor is regulated for high speed it is not adjusted correctly for low speed.

WM. POLACHEK.

Milwaukee, Wis.

1. The ideal carburetor would furnish a perfect mixture in all senses of the word at all engine speeds and under all conditions of atmospheric humidity.

2. The resistance offered to the incoming air by the carburetor passages is negligible in any of the modern carburetors.

3. The horsepower expended in drawing the air into the mixing chamber is so small that it is not worth attention in figuring the efficiency of the motor.

### Has Leaky Tire

Editor THE AUTOMOBILE:

[2,867]—I have a slow puncture in the inner tube and I cannot locate it by listening for a leak, and I would like to know how it is possible to determine the leads in inner tubes when they are so small as to be invisible.

If the tire is porous will it hold the air for a time and then allow it to leak out of the inner tube or will there be a continuous leak?

CHAS. CAMMON.

Burlington, Vt.

The tires are easily tested by placing them when inflated in a deep pan of water such as is shown in Fig. 4. It is a very good plan to hang the tire above the pan as shown and to slowly turn it about. The presence of bubbles will indicate a leak. If the entire surface of the tire is covered with bubbles it will indicate a porous condition of the tire. When a tire is porous the leak will be continuous, the tire not being able to hold the air it contains for any time.

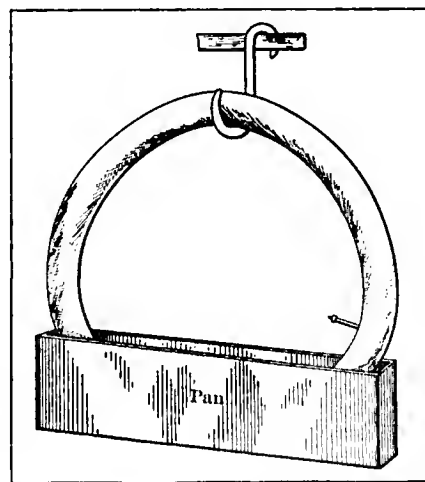

Fig. 4—Method of supporting tire when testing for leaks



# Little Bits of Motor Wisdom

## Pertinent Pointers for Repairman and Driver

**S**PRINGS MUST BE CAREFULLY FASTENED—A chassis spring can attain the height of its usefulness and efficiency only when it is fastened in the proper manner. The object of springs is to increase the comfort of riding by arresting shocks which may be transmitted from the road to the body of the car through the chassis. Hence the springs are inserted between the body and the chassis in order to absorb these shocks. Shocks are caused by rapid changes of condition; that is, the rapid arresting of motion or the rapid starting of a stationary body. Hence if the car is started in a downward direction by falling into the small irregularities of the road, instead of being brought to rest with a jar, the shock will be absorbed to a large degree by the springs, which will bring the body of the car slowly to rest. When the wheels of the vehicle pass over an obstruction or sink into a hollow of the road, they alternately expand and compress the springs so that very little of the shock is felt by the passengers.

The three most common springs used in modern automobile body work are the elliptic, three-quarter-elliptic and the semi-elliptic. The first variety, the elliptic, have

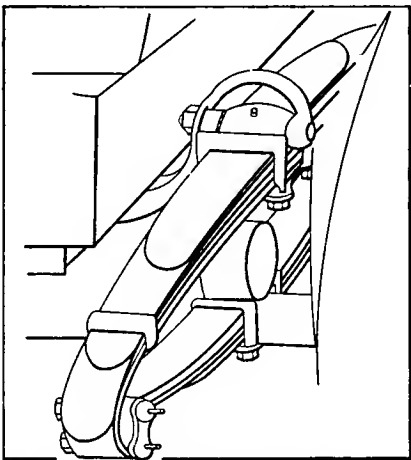

Fig. 1—Showing method of fastening scroll elliptic spring.

the halves each a semi-elliptic, fastened together at the ends so that an ellipse is built up. The fastening is generally by means of bolts which pass through the spring ends; the upper and lower halves are connected at the center of their lengths to the frame and axle respectively by means of bolts or clips. These bolts and clips should be fastened in such a way that they do not interfere with the motion of the

leaves of the spring, nor should they weaken the spring at the point of application.

The leaves of the springs, which are built up in the manner of those mentioned above, slide over one another as the spring is compressed or expanded. In the elliptic type the spring is elongated under the influence of a load; that is, the members of the spring become more nearly straight as the curvature is reduced. Since the curvature is reduced, each leaf of the spring attains a greater over-all length, and hence the ends of each leaf must slip over the leaf below. It is evident that the springs must not be fastened at any point which will interfere with this motion; therefore they can only be attached rigidly at the center of their length, since this point does not change relatively to the center of the length of any of the other leaves no matter how the spring is compressed or allowed to expand.

Some of the methods of making this fastening are depicted in Figs. 1, 2 and 3. In Fig. 1 a variation of the elliptic type of spring, known as the scroll elliptic, is shown. This spring consists of two members joined by shackles, the top half being a scroll and the lower half a semi-elliptic. The method of joining this spring to the axle and frame may be seen in this illustration. The fastening consists of two clips of inverted U shape, the ends of which pass through a flange of the frame beneath the spring. This is similar in many respects to the method illustrated in Fig. 2. In this case the inverted U clips are used as shown in Fig. 1, and besides this an additional clip is used between the two U clips, consisting of a plate with two bolts passing through it and also through the holding flange.

In Fig. 3 another method of fastening the spring is shown, a special bracket being employed, in this case consisting of two struts and a flange plate through which the bolts pass. The dotted lines indicate a plate which has been removed in order to show the supporting bracket.

The two other springs described, the semi-elliptic and the three-quarter elliptic, are, as suggested by their names, either a half-ellipse or a half-ellipse with a quarter-ellipse added. They are fastened in the same manner at the bottom as the elliptic, the difference being in the manner of supporting the top or frame joint. They are usually held by shackles which are supported by the frame, and in the case of the three-quarter elliptic springs the end of

the quarter-ellipse rests upon a platform.

The principal point to observe in fastening the springs is that nothing is done to weaken the spring by piercing it with holes of a dangerous diameter or by cutting it in any way. It must be remembered that the greatest strain on the spring is at the point at which it supports the weight, in the great majority of cases, since this occurs at

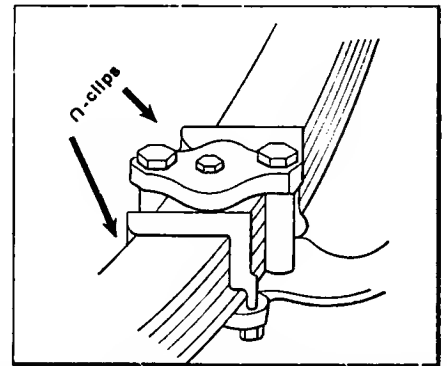

Fig. 2—Illustrating the inverted U-clips employed in holding spring.

the center of the spring, and as the fastening is also at that point great care must be taken that too much material is not cut away in making the fixture.

**ADJUSTING VALVE STEMS**—As the valves are ground down the valve stems are gradually lowered. The lowering is very slight on each grinding of the valve, as very little material is taken off the surface of the valve at each grinding; but after the valve has been repeatedly resealed the lowering of the valve stem will be so great that it will be necessary to adjust it in order that the lift of the valves will be correct. The space between the valve push rods and stems should be about 1-32 inch and can be determined by inserting a feeler gauge, or if there is no feeler gauge available at the time a piece of cardboard about twice the thickness of the average business card may be employed.

The adjusting nuts are then turned so that the valve stem will have the proper clearance as determined by the gauge or doubled card. After the adjustment is made it should always be checked by determining if the valve remains closed during the period required. This is done by taking a piece of thin paper and inserting it beneath the stem of the valve and the engine turned slowly over through the part of the stroke in which the valve is supposed to remain closed. The paper is frequently

moved about during this process and if it is pinched at any time it is a sign that the adjustment is not correct, since the pinching of the paper indicates the point at which the valve starts to open. If the pinching takes place at the proper time for the opening of the valve the closing time should also be noted. This is done in just the opposite manner in which the opening time is determined. The paper is continually pinched by the valve stem until it is time for the valve to close, when the paper should be released. The flywheel is generally marked so that the timing as given by the card test can be checked by this. If it is not marked the position of the crank handle will act as a guide in the matter or the position of the piston may be determined by removing a pet-cock or other fitting from

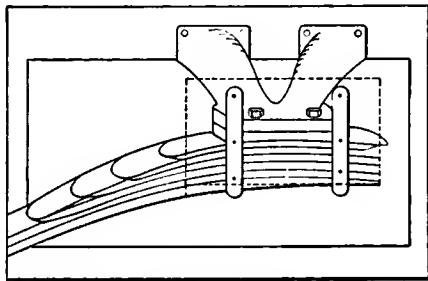

Fig. 3—Method of supporting spring by means of a flanged bracket

the top of the cylinder and inserting a stick which will be lifted by the piston on its travel. It is much better and handier, however, to have the flywheel marked for the opening and closing position of each valve as well as for the upper and lower dead centers of the motor.

The clearance allowed between the valve stem and push rod is very necessary and should not be overlooked in adjusting the valve-lifting mechanism, as the rod will materially expand after the engine has been running for a length of time and has become warmed up. The clearance should not be too great, however, as this would cause the valve to open later than was intended. In the case of the exhaust valve the exploded gases would not have time to be well cleared out of the cylinder, and what remained would dilute the fresh charge to such an extent that the power of the engine would be materially cut down. In the case of an inlet valve the opening of the valve would be delayed and the required weight of charge would not be drawn into the cylinder and the consequence would also be a loss of power.

**LUBRICATING SPRINGS**—Lubrication is another great factor in the well-being of the spring and is next to the fastening in importance. In absorbing the shocks of the road the different laminations of the spring slide upon each other and in order that they do so in as easy a manner as possible it is necessary that they be well lubricated. There are various means in use

of keeping the springs properly greased, most of these consisting of a series of grooves and slots. The oil is generally applied by jacking up the frame of the motor, which will cause the various leaves of the spring to separate, since all the strain is taken off the spring; it is then very easy to cover the leaves with heavy cylinder oil.

The spring bolts and shackles are fitted, as a rule, with grease cups, which should be given a full turn about every 100 miles or once a day. This is a very important operation so far as the noiseless action of the car is concerned. The oil not only insures easy action of the springs but also acts as a rust preventive while the car is not in use.

**DO NOT START ON SPARK**—A practice which has been in vogue for some time is to open the throttle after the spark has been shut off when stopping the engine, and while it is still running under its own momentum to allow it to draw in a charge of gas in at least one of the cylinders. The spark is then switched on when the driver wishes to start the engine, and in the case of a six-cylinder motor, and very often in a four-cylinder, the piston will be in firing position in one of the cylinders and the motor will start. While this does away with the necessity of cranking the motor, it is not by any means beneficial to it, as the full shock of the explosion is taken up by the motionless parts and the consequent inertia is very great.

The effect of starting upon the spark is very much the same as if the head of the motor were hit a very severe blow with a heavy sledge, muffled in such a way that there is no metallic contact between the cylinder head and the sledge. The jar given to the motor is extremely heavy and is hence to be avoided. The life of a motor which has been continually started upon the spark will be decreased materially as compared with one which is always started by cranking.

**KEEPING MAIN BEARINGS COOL**—Within the crankcase of the automobile motor there is always present a mist of oil without regard to the system of oiling used. When the splash system of oiling is used this mist assumes the proportions of a spray and pervades the crankcase to such an extent that the actual running temperature of the lower part of the motor is reduced owing to its cooling influence.

The main bearings are often lubricated solely by the oil mist which works its way into the bearings; but this in some cases is not sufficient, a long bearing being apt to overheat. To prevent an occurrence of this nature the bearing casing is often recessed so as to form a sort of cup on the upper half. Holes are then drilled through the upper part of the bearing casing, so that there is a lead from the cup to the bearing through which the oil slowly seeps and dis-

tributes itself along the length of the bearing and drips out at the ends. The manner in which these ducts are often cut in the bearing casing is shown in Fig. 4, where the pockets are labeled and the holes from these are shown leading down to the bearing surface.

The main bearings are usually amply supplied where the force-feed system is used, as there is a lead from the pump directly to each of these bearings. The oil is often supplied in a case of this kind under considerable pressure, so that when a hollow crankshaft is employed to distribute the oil the centrifugal force due to the revolving crankshaft may be overcome in forcing the oil into the center of the shaft. The oil lead to the bearing registers with the opening into the crankshaft during a part of each revolution, and during this time the oil is forced into the crankshaft. During the remainder of the time the oil is forced into the bearing itself.

A very common means of lubricating the main bearings which has found considerable favor in recent years is to employ a combination force-feed and splash system. When this method is used there is a lead from the source of oil supply, whether it be from the sight feed or pump, to the main bearings. Thus far the system is the same as the force-feed type, but instead of leading the oil through a hollow crankshaft, or through independent leads to the cylinder walls and connecting rod bearings, the remainder of the lubrication outside of the main bearings is accomplished by the splash system. The oil is allowed to overflow from the main bearings into the splash compartments on either side of the main bearing bridges. Since the oil is supplied to the main bearings in this case very rapidly, the splash troughs are always kept

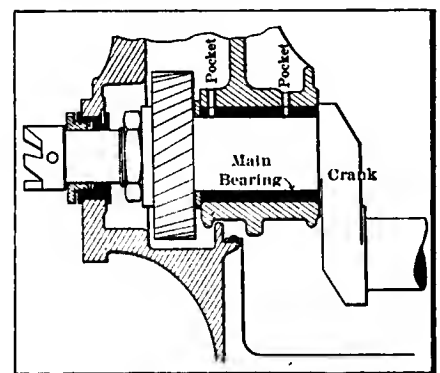

Fig. 4—Showing the oil ducts often cut through the main bearings

full and overflowing, and the main bearings very amply lubricated and adequately cooled. When this method of oiling is employed it should be made a point that the oil is allowed to flow to either end of the bearing so that there is an overflow in either direction. This can be done by having the oil lead directly in the center of the bearing and by supplying an adequate quantity of oil.

# My 1912 Automobile

## Some Conceptions of What the Ideal Car Should Be.

### A \$5,000 Car

Editor THE AUTOMOBILE:

I would like to see an announcement along the following lines by some leading producer of high-grade cars: Motor, six-cylinder, Knight type; bore, 4 3/4; stroke, 6 inches; four speed selective transmission with direct drive on fourth.

Self-contained force feed and splash oiling systems.

I would specify a worm drive for the sake of silence and gas and spark control on top of steering wheel.

Double ignition should be installed and also a high-tension complete electric-lighting system, including dynamo.

Compressed air starting device, available for inflating tires, should be installed and also a carburetor air adjustment on steering column. The multiple disc clutch should run in oil.

The radiator and hood should be similar to Renault type, giving protection to radiator, better view of road, and (in my opinion) handsomer lines. I would specify an underslung frame for following reasons: 1st. A very large per cent of fatal accidents are caused by overturning. Any feature which lessens this danger seems to me important. 2d. Ease of entering car. 3d. Appearance.

The wheels should be of a size to give minimum road clearance of 11 inches. Steering column should have an extreme inclination (as in Lozier torpedo) for ease in steering, while the tires should be carried at rear, in an upright position.

Fore-door torpedo body, with comfortably high sides and backs and thick upholstery, is my choice, with overhanging cowl, carried well up and back toward steering wheel; seats 12 inches high from floor and a wheelbase of length to insure ample foot room for all occupants, especially in the front seats (say, 140 inches for six-passenger torpedo). Extra seats should be removable and a clamp for baggage should be on the running board. To insure beauty of outline the body lines should not exceed in height the top of the radiator and hood. Particular attention ought to be paid to all parts and adjustments, especially grease cups, the replenishing of which, on many cars, causes sinful language daily. A two-gallon reserve oil tank and a gas tank of 250 miles capacity, with drain cock for quick emptying of same, should be fitted. Rubber cushions between chassis and body to prevent squeaks should be a feature.

I would specify a full equipment, including speedometer, clock and windshield, with stay rods extending no farther in front than the dash. Top and demountable rims of course. The above figures are in no particular intended as exact. They merely express in a general way my ideal of a car and costing around \$5,000. It is my impression that such a car would take with the class of buyers who want the best.

Putnam, Conn.

C. O. M.

### Likes a Heavy Car

Editor THE AUTOMOBILE:

No two people have the same ideas of cars, and each one believes in his own selections, but I am sure that a great many people will agree with most of my selections. I shall not give specifications of body design or length, width and number of spring leaves, etc., but will confine myself to the following:

The motor should be of the (T) head type, five-inch bore and six-inch stroke, four cylinders cast in pairs, with three-bearing crankshaft and valves two and three-fourth inches in diameter.

Four-speed transmission with three to one on fourth would give plenty of speed when desired and also produce a very quiet and easy running engine at moderate speed. The large engine would give plenty of power on the hills and with this transmission would prove more economical than a smaller engine. The gearset should be carried amidships, bolted to the frame.

The ignition should be double. I mean by double two separate systems even down to the switches. This allows both systems to be used at once.

The carbureter should be a multiple jet with auxiliary air intake to be regulated by hand from under the steering-wheel. This would give a very strong and flexible carbureter.

Lubrication should be by splash from oil troughs, oil reservoir being in bottom of crankcase. Oil should be pumped through a sight feed on dash; after being used it should be strained and sent through again.

Clutch would be of the expanding band type with cork inserts and a screw adjustment. This clutch would be extremely easy to remove and to adjust.

Drive should be through a shaft, direct drive being on fourth speed.

Steering should be by irreversible worm and sector gear. This design is adjustable and does not allow any of the road shocks

to be transmitted to the driver's arms.

The springs should be of the platform type in the rear and semi-elliptic in front which ought to make an easy riding car.

Wheelbase should be 120 inches and tires all round 36 x 4 1/2.

Front axles should be I-beam with full floating axles in the rear. Full floating axles allow all weight to be carried upon the axle housing and wheels, while the axle has only the driving strain to take care of.

The body should have plenty of leg room in both seats; eleven inch clearance is required. Special attention should be given to the depth of seats and a space in car for extra tires.

Control should be above the steering wheel, moving upward. Accelerator outside of clutch and brake pedals.

The two brakes should both work on the wheel drums, foot brake contracting, with emergency expanding.

This car could be built and marketed for \$2,500 and should not weigh more than 3,400 pounds. Most people want light weight cars on account of the tire cost, but they must be careful not to rob the easy riding qualities of the car by making it light, besides the strength of each part necessarily comes before the question of weight.

W. J. MARLIN.

Du Bois, Pa.

### Wants the Car Well Made

Editor THE AUTOMOBILE:

There is an old saying that we want but little here below, but in my ideal car I might add that we want that little good. A motor with about 4-inch bore and 4 3/4-inch stroke capable of attaining 2,500 revolutions per minute, cone clutch, three speed selective transmission and worm drive would be the main characteristics. The magneto should be of the double-distributor type and the chassis should not weigh more than 1,600 pounds.

Price cutting in automobile manufacture must entail some cut either in material or workmanship and it is my firm belief that if a car were made of the best and the makers satisfied with a reasonable margin of profit there would be room for such a concern in the automobile business. The time will come when a car will sell on its merits rather than the fact that it is a few dollars cheaper than that made by some other competitor.

M. P. H.

New York.

# My Best Repair

## A Chapter of Accidents

I WAS once confronted by what seemed to be a breakdown that would necessitate the car being towed into the nearest town or taking the gasoline tank off the car and taking it to some repair shop.

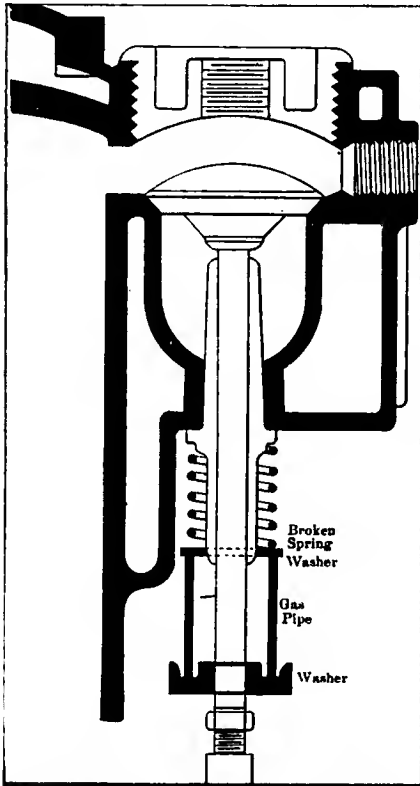

Fig. 1—Method of temporarily repairing a broken valve spring with a piece of gas pipe

Briefly what happened was as follows: I was driving a car over some very bumpy roads and the pipe inside the gasoline tank became unsoldered. The pipe carried the gasoline from the bottom of the tank under pressure so that when it broke it was impossible to feed the carbureter from the tank. The tank contained about 18 gallons of gasoline and at first I thought that there was a leak in the pressure circuit, but upon removing the cover of the float chamber I found that the pressure passed clean through the gasoline line. The filler of the tank was rather small; too small, in fact, to allow of putting the hand inside. Just at that moment a small boy was passing and with the aid of a few cents I prevailed upon him to put his hand inside and feel around to see if the pipe was broken or not. He was able to reach it, but as it lay at the bottom of the tank and there were baffle plates it was not possible to remove it.

The thought occurred to me to use a spare can of gasoline and syphon it out, but as I did not have a can on board I had to

walk some distance to a house to procure one. Then came the question of syphoning the gasoline from the main tank to the improvised one and from the latter to the carbureter. The rubber connection of the tire pump served for the first operation all right, but was not long enough for the second. I took the copper pipe from the acetylene system and attached a piece of rubber tubing at each end, inserting one end in the emergency tank, which I placed in my companion's arms, as shown in Fig. 2.

A triangular file served as a hack-saw to cut the gasoline pipe about 10 inches from the carbureter. The only way to start the syphon working was to suck on it with my mouth and quickly connecting up the rubber tube to the feed pipe. The contraption lasted for about one hour, just sufficient to get me home, as the rubber was eaten away by the gasoline passing through it.

I learned, however, that using a flame on the gasoline tank was a very delicate operation even after leaving it for several hours with the filler and drain plugs removed. To make sure I pumped air with a tire pump through the tank for fully half an hour, but as soon as a flame was applied to remove the solder around the joint a terrific explosion took place and a fantail flame exuded from the filler, lapping the right side of my face. There happened to be a gear box that had been opened up, and I plunged my hand into it and smeared my face with the lubricant, which prevented the burn from taking much more effect than singeing my hair and causing the skin to peel.

New York.

H. M.

## Broken Valve Spring Repair

Being away on a tour and trusting to others to see that the car was in good shape before starting I had the misfortune to break a valve spring. Such a thing had never happened to me before, and I had neglected to carry a spare spring. I believe in always carrying a good piece of copper wire, a pair of pliers, adjustable wrench and hacksaw. With these three a repair can be made, as was proven in the present instance. The jack handle of my car was tubular, in fact, similar to a piece of gas pipe, so I cut off a sufficient length so as to insert it between the valve washer and a washer I happened to have on the car. By "happened" I mean I looked around the car till I came to one of the brake connections that had washers fitted and I removed it. The sketch shown in Fig. 1 illustrates the repair as executed.

Philadelphia.

T. W. WOLF.

## Burnt-Out Bearing—Got Home

I cannot remember ever having been called upon to exert any gray matter on the road in extricating myself from an embarrassing situation.

I remember once, however, that my engine began to pound in the front cylinder and upon removing the inspection cover I found that the bearing, which was of white metal, had started to run. Upon removing the connecting rod and piston from the cylinder I ran home on "three," averaging about 10 miles per hour.

Hartford.

BURNT OUT.

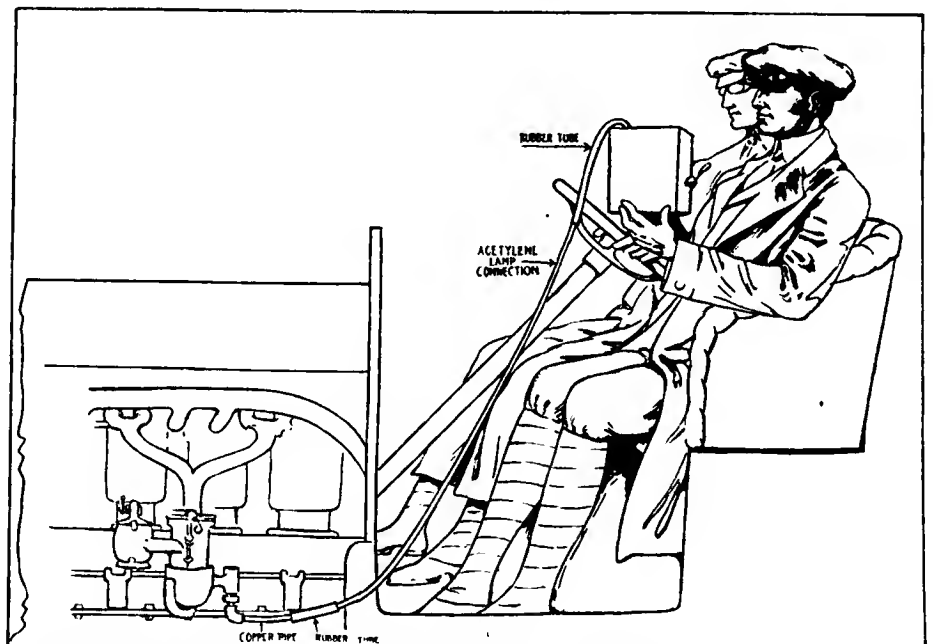

Fig. 2—Getting home with a defective gasoline tank by using the acetylene connections

# M. & A. M. Allots Show Spaces

COMPLETE allotments of space for the shows in Madison Square Garden, New York; Coliseum and Armory, Chicago, and Mechanics' Hall, Boston, have been announced by the Motor and Accessory Manufacturers. The spaces for the exhibition in the New Grand Central Palace have not yet been assigned. Below is a list of the accessories exhibitors at the three shows mentioned:

## Madison Square Garden for Both Weeks.

Ajax-Grieb Rubber Co., New York, N. Y.  
 American Ball-Bearing Co., Cleveland, Ohio.  
 American Circular Loom Co., Aldene, N. J.  
 Apple Electric Co., Dayton, Ohio.  
 The Badger Brass Mfg. Co., Kenosha, Wis.  
 The Baldwin Chain & Mfg. Co., Worcester, Mass.  
 Bosch Magneto Co., New York, N. Y.  
 S. F. Bowser & Co., Fort Wayne, Ind.  
 Briscoe Mfg. Co., Detroit, Mich.  
 Brown-Lipe Gear Co., Syracuse, N. Y.  
 Byrne, Kingston & Co., Kokomo, Ind.  
 Champion Ignition Co., Flint, Mich.  
 The Chandler Co., Springfield, Mass.  
 Chicago Telephone Supply Co., Elkhart, Ind.  
 Coes Wrench Co., Worcester, Mass.  
 Columbia Lubricants Co., New York, N. Y.  
 Columbia Nut & Bolt Co., Bridgeport, Conn.  
 The Connecticut Telephone & Electric Co., Meriden, Conn.  
 Consolidated Rubber Tire Co., New York, N. Y.  
 Continental Caoutchouc Co., New York, N. Y.  
 Covert Motor Vehicle Co., Lockport, N. Y.  
 The Wm. Cramp & Sons Ship & Engine Building Co., Philadelphia, Pa.  
 Crucible Steel Co., Pittsburgh, Pa.  
 The Dean Electric Co., Elyria, Ohio.  
 Diamond Chain & Mfg. Co., Indianapolis, Ind.  
 The Diamond Rubber Co., Akron, Ohio.  
 Jos. Dixon Crucible Co., Jersey City, N. J.  
 Dorian Remountable Rim Co., New York, N. Y.  
 Driggs-Seabury Ordnance Corp., Sharon, Pa.  
 Edison Storage Battery Co., West Orange, N. J.  
 The Edmunds & Jones Mfg. Co., Detroit, Mich.  
 Eisemann Magneto Co., New York, N. Y.  
 The Electric Storage Battery Co., Philadelphia, Pa.  
 Empire Tire Co., Trenton, N. J.  
 Firestone Tire & Rubber Co., Akron, Ohio.  
 The Fisk Rubber Co., Chicopee Falls, Mass.  
 G. & J. Tire Co., Indianapolis, Ind.  
 Gemmer Mfg. Co., Detroit, Mich.  
 The B. F. Goodrich Co., Akron, Ohio.  
 The Goodyear Tire & Rubber Co., Akron, Ohio.  
 Gray & Davis, Amesbury, Mass.  
 The R. E. Hardy Co.,  
 A. W. Harris Oil Co., Providence, R. I.  
 Hartford Rubber Works Co., Hartford, Conn.  
 Hartford Suspension Co., Jersey City, N. J.  
 Havoline Oil Co., New York, N. Y.  
 Herz & Co., New York, N. Y.  
 The Hess-Bright Mfg. Co., Philadelphia, Pa.  
 The Hoeffcker Co., Boston, Mass.  
 Hyatt Roller Bearing Co., Newark, N. J.  
 Janney-Steinmetz & Co., Philadelphia, Pa.  
 Isaac G. Johnson & Co., New York, N. Y.  
 Phineas Jones & Co., Newark, N. J.  
 Jones Speedometer Co., New York, N. Y.  
 Atwater Kent Mfg. Works, Philadelphia, Pa.  
 Kokomo Electric Co., Kokomo, Ind.  
 Leather Tire Goods Co., Niagara Falls, N. Y.  
 Lebanon Steel Casting Co., Lebanon, Pa.  
 J. Ellwood Lee Co., Conshohocken, Pa.  
 Light Mfg. & Foundry Co., Pottstown, Pa.  
 Link-Belt Co., Indianapolis, Ind.  
 Lovell-McConnell Mfg. Co., Newark, N. J.  
 McCord Mfg. Co., Detroit, Mich.  
 The McCue Co., Buffalo, N. Y.  
 C. A. Mezzer, New York, N. Y.  
 Michelin Tire Co., Milltown, N. J.  
 Morran & Wright, Detroit, Mich.  
 A. R. Mosler & Co., New York, N. Y.  
 The Motz Clincher Tire & Rubber Co., Akron, Ohio.  
 Muncie Gear Works, Muncie, Ind.  
 National Carbon Co., Cleveland, Ohio.  
 National Tube Co., Pittsburgh, Pa.  
 The New Departure Mfg. Co., Bristol, Conn.  
 N. Y. & N. J. Lubricant Co., New York, N. Y.  
 The Noera Mfg. Co., Waterbury, Conn.  
 Oliver Mfg. Co., Chicago, Ill.  
 Pennsylvania Rubber Co., Jeannette, Pa.  
 Pittsfield Spark Coil Co., Dalton, Mass.  
 Remy Electric Co., Anderson, Ind.  
 The Republic Rubber Co., Youngstown, Ohio.  
 The Royal Equipment Co., Bridgeport, Conn.  
 A. O. Smith Co., Milwaukee, Wis.  
 The Sparks-Withington Co., Jackson, Mich.  
 Spicer Mfg. Co., Plainfield, N. J.  
 C. F. Splittorf, New York, N. Y.  
 Standard Roller Bearing Co., Philadelphia, Pa.  
 The Standard Welding Co., Cleveland, Ohio.  
 Stewart & Clark Mfg. Co., Chicago, Ill.  
 Stromberg Motor Devices Co., Chicago, Ill.

Swinehart Tire & Rubber Co., Akron, Ohio.  
 The Timken-Detroit Axle Co., Detroit, Mich.  
 The Timken Roller Bearing Co., Canton, Ohio.  
 The Turner Brass Works, Sycamore, Ill.  
 U. S. Light & Heating Co., New York, N. Y.  
 Vacuum Oil Co., New York, N. Y.  
 Vanadium Metals Co., Pittsburgh, Pa.  
 The Veeder Mfg. Co., Hartford, Conn.  
 Warner Gear Co., Muncie, Ind.  
 Warner Mfg. Co., Toledo, Ohio.  
 Weed Chain Tire Grip Co., New York, N. Y.  
 Weston-Mott Co., Flint, Mich.  
 Wheeler & Schbler, Indianapolis, Ind.  
 Whitney Mfg. Co., Hartford, Conn.  
 J. H. Williams Co., Brooklyn, N. Y.  
 O. W. Young, Newark, N. J.  
 Federal Rubber Mfg. Co., Cudaby, Wis.  
 Detroit Electric Appliance Co., Detroit, Mich.  
 Carnegie Steel Co., Pittsburgh, Pa.  
 Automobile Supply Mfg. Co., Brooklyn, N. Y.  
 The Simms Magneto Co., New York, N. Y.  
 International Acheson Graphite Co., Niagara Falls, N. Y.  
 The Buda Co., Harvey, Ill.  
 Stutz Auto Parts Co., Indianapolis, Ind.  
 Bower Roller Bearing Co., Detroit, Mich.  
 United Rim Co., Akron, Ohio.  
 Jacobson-Brandow Co., Pittsfield, Mass.  
 General Electric Co., Schenectady, N. Y.

## Madison Square Garden for First Week Only

Allen Auto Specialty Co., New York, N. Y.  
 Auburn Auto Pump Co., Boston, Mass.  
 The A-Z Co., New York, N. Y.  
 Briggs & Stratton Co., Milwaukee, Wis.  
 Continental Rubber Works Co., Erie, Pa.  
 Adam Cooks' Sons, New York, N. Y.  
 C. Cowles & Co., New Haven, Conn.  
 Dover Stamping & Mfg. Co., Cambridge, Mass.  
 Gabriel Horn Mfg. Co., Cleveland, Ohio.  
 The Gilbert Mfg. Co., New Haven, Conn.  
 Globe Machine & Stamping Co., Cleveland, Ohio.  
 Gray-Hawley Mfg. Co., Detroit, Mich.  
 George A. Haws, New York, N. Y.  
 Hayes Mfg. Co., Detroit, Mich.  
 Heinze Electric Co., Lowell, Mass.  
 Hodgman Rubber Co., New York, N. Y.  
 Kellogg Mfg. Co., Rochester, N. Y.  
 National Coil Co., Lansing, Mich.  
 The Pantasote Co., New York, N. Y.  
 Rose Mfg. Co., Philadelphia, Pa.  
 J. H. Sager Co., Rochester, N. Y.  
 The Seamless Rubber Co., New Haven, Conn.  
 C. A. Shaler Co., Waupun, Wis.  
 The Sprague Umbrella Co., Norwalk, Ohio.  
 The Springfield Metal Body Co., Springfield, Mass.  
 The Stein Double Cushion Tire Co., Akron, Ohio.  
 Valentine & Co., New York, N. Y.  
 Vesta Accumulator Co., Chicago, Ill.  
 Warner Instrument Co., Beloit, Wis.  
 Western Tool & Forge Co., Brackenridge, Pa.  
 White & Bagley Co., Worcester, Mass.  
 The Willard Storage Battery Co., Cleveland, Ohio.  
 The Manufacturers Foundry Co., Waterbury, Conn.  
 Doehler Die-Casting Co., Brooklyn, N. Y.  
 The Hess Spring & Axle Co., Carthage, Ohio.  
 The G. Piel Co., New York, N. Y.  
 The Esterline Co., Lafayette, Ind.  
 Universal Wind Shield Co., Chicago, Ill.  
 The Batavia Rubber Co., Batavia, N. Y.  
 Double Fabric Tire Co., Auburn, Ind.  
 Voorhees Rubber Mfg. Co., Jersey City, N. J.  
 Wolverine Lubricants Co., New York, N. Y.

## Chicago Show for Both Weeks

Ajax-Grieb Rubber Co., New York, N. Y.  
 American Ball Bearing Co., Cleveland, Ohio.  
 American Circular Loom Co., Aldene, N. J.  
 Apple Electric Co., Dayton, Ohio.  
 Auto Parts Mfg. Co., Muncie, Ind.  
 The Badger Brass Mfg. Co., Kenosha, Wis.  
 The Baldwin Chain & Mfg. Co., Worcester, Mass.  
 Bosch Magneto Co., New York City.  
 S. F. Bowser & Co., Fort Wayne, Ind.  
 Briscoe Mfg. Co., Detroit, Mich.  
 Brown-Lipe Gear Co., Syracuse, New York.  
 Byrne, Kingston & Co., Kokomo, Ind.  
 Champion Ignition Co., Flint, Mich.  
 The Connecticut Telephone & Elec. Co., Meriden, Conn.  
 Consolidated Rubber Tire Co., New York, N. Y.  
 Continental Caoutchouc Co., New York, N. Y.  
 Continental Motor Mfg. Co., Muskegon, Mich.  
 Covert Motor Vehicle Co., Lockport, New York.  
 The Wm. Cramp & Sons Ship & Engine Bldg. Co., Philadelphia, Pa.  
 The Dean Electric Co., Elyria, Ohio.  
 Diamond Chain & Mfg. Co., Indianapolis, Ind.  
 The Diamond Rubber Co., Akron, Ohio.  
 Driggs-Seabury Ordnance Corp., Sharon, Pa.  
 Edison Storage Battery Co., West Orange, New Jersey.  
 The Edmunds & Jones Mfg. Co., Detroit, Mich.  
 Eisemann Magneto Co., New York City.  
 The Electric Storage Battery Co., Philadelphia, Pa.



Empire Tire Co., Trenton, New Jersey.  
 Firestone Tire & Rubber Co., Akron, Ohio.  
 The Fisk Rubber Co., Chicopee Falls, Mass.  
 G. & J. Tire Co., Indianapolis, Ind.  
 Gommer Mfg. Co., Detroit, Mich.  
 The B. F. Goodrich Co., Akron, Ohio.  
 The Goodyear Tire & Rubber Co., Akron, Ohio.  
 Gray & Davis, Amesbury, Mass.  
 C. T. Ham Mfg. Co., Rochester, New York.  
 The R. E. Hardy Co., Chicago, Ill.  
 A. W. Harris Oil Co., Providence, R. I.  
 The Hartford Rubber Works Co., Hartford, Conn.  
 Hartford Suspension Co., Jersey City, New Jersey.  
 Havoline Oil Co., New York City.  
 Herz & Co., New York City.  
 The Imperial Brass Mfg. Co., Chicago, Ill.  
 Isaac G. Johnson & Co., Spuyten Duyvil, N. Y. City.  
 Jones Speedometer Co., New York, N. Y.  
 Atwater Kent Mfg. Works, Philadelphia, Pa.  
 Kinsey Mfg. Co., Toledo, Ohio.  
 Kokomo Electric Co., Kokomo, Ind.  
 Leather Tire Goods Co., Niagara Falls, New York.  
 J. Ellwood Lee Co., Conshohocken, Pa.  
 W. H. Leland & Co., Worcester, Mass.  
 Link-Belt Co., Indianapolis, Ind.  
 Lovell-McConnell Mfg. Co., Newark, New Jersey.  
 McCord Mfg. Co., Detroit, Mich.  
 Michelin Tire Co., Milltown, New Jersey.  
 Morgan & Wright, Detroit, Mich.  
 A. R. Mosler & Co., New York City.  
 The Motz Clincher Tire & Rubber Co., Akron, Ohio.  
 Muncie Gear Works, Muncie, Ind.  
 National Carbon Co., Cleveland, Ohio.  
 National Coil Co., Lansing, Mich.  
 National Tube Co., Pittsburg, Pa.  
 N. Y. & N. J. Lubricant Co., New York City.  
 Oliver Mfg. Co., Chicago, Ill.  
 Pennsylvania Rubber Co., Jeannette, Pa.  
 Pittsfield Spark Coil Co., Dalton, Mass.  
 Remy Electric Co., Anderson, Ind.  
 The Republic Rubber Co., Youngstown, Ohio.  
 Ross Gear & Tool Co., Lafayette, Ind.  
 The Royal Equipment Co., Bridgeport, Conn.  
 The Sparks-Witbington Co., Jackson, Mich.  
 Spicer Mfg. Co., Plainfield, New Jersey.  
 C. F. Splitdorf, New York City.  
 Standard Roller Bearing Co., Philadelphia, Pa.  
 The Standard Welding Co., Cleveland, Ohio.  
 Stewart & Clark Mfg. Co., Chicago, Ill.  
 Stromberg Motor Devices Co., Chicago, Ill.  
 Swinehart Tire & Rubber Co., Akron, Ohio.  
 The Timken-Detroit Axle Co., Detroit, Mich.  
 The Timken Roller Bearing Co., Canton, Ohio.  
 The Turner Brass Works, Sycamore, Ill.  
 The U. S. Light & Heating Co., New York City.  
 The Veeder Mfg. Co., Hartford, Conn.  
 Vesta Accumulator Co., Chicago, Ill.  
 Warner Gear Co., Muncie, Ind.  
 Warner Mfg. Co., Toledo, Ohio.  
 Weed Chain Tire Grip Co., New York City.  
 Western Motor Co., Marion, Ind.  
 Weston-Mott Co., Flint, Mich.  
 Wheeler & Schebler, Indianapolis, Ind.  
 Whitney Mfg. Co., Hartford, Conn.  
 J. H. Williams Co., Brooklyn, New York.  
 Federal Rubber Co., Cudahy, Wis.  
 Detroit Electric Appliance Co., Detroit, Mich.  
 Waukesha Motor Co., Waukesha, Wis.  
 The Esterline Co., Lafayette, Ind.  
 The Simms Magneto Co., New York City.  
 Falls Machine Co., Sheboygan Falls, Wis.  
 International Acheson Graphite Co., Niagara Falls, New York.  
 The Buda Co., Harvey, Ill.  
 Stutz Auto Parts Co., Indianapolis, Ind.  
 The United Rim Co., Akron, Ohio.  
 Jacobson-Brandow Co., Pittsfield, Mass.  
 General Electric Co., Sebectady, N. Y.

#### Chicago Show for First Week Only

Allen Auto Specialty Co., New York City.  
 Auburn Auto Pump Co., Boston, Mass.  
 Avery Portable Lighting Co., Milwaukee, Wis.  
 Booth Demountable Rim Co., Detroit, Mich.  
 Briggs & Stratton Co., Milwaukee, Wis.  
 Columbia Lubricants Co., New York, N. Y.  
 Continental Rubber Works Co., Erie, Pa.  
 Adam Cook's Sons, New York, N. Y.  
 C. Cowles & Co., New Haven, Conn.  
 Jos. Dixon Crucible Co., Jersey City, New Jersey.  
 Dorian Remountable Rim Co., New York City.  
 Dover Stamping & Mfg. Co., Cambridge, Mass.  
 The Globe Machine & Stamping Co., Cleveland, Ohio.  
 Gray-Hawley Mfg. Co., Detroit, Mich.  
 George A. Haws, New York, N. Y.  
 Hayes Mfg. Co., Detroit, Mich.  
 Heinze Electric Co., Lowell, Mass.  
 The Hofferker Co., Boston, Mass.  
 Kellogg Mfg. Co., Rochester, New York.  
 The McCue Co., Buffalo, New York.  
 The Pantasote Co., New York City.  
 J. H. Sager Co., Rochester, New York.  
 C. A. Shaler Co., Waupun, Wis.  
 A. O. Smith Co., Milwaukee, Wis.  
 The Sprague Umbrella Co., Norwalk, Ohio.

The Stein Double Cushion Tire Co., Akron, Ohio.  
 Valentine & Co., New York City.  
 Warner Instrument Co., Beloit, Wis.  
 Western Tool & Forge Co., Brackenridge, Pa.  
 The Willard Storage Battery Co., Cleveland, Ohio.  
 Doehler Die Casting Co., Brooklyn, New York.  
 The Hess Spring & Axle Co., Carthage, Ohio.  
 The G. Piel Co., New York City.  
 Universal Wind Shield Co., Chicago, Ill.  
 Universal Tire Protector Co., Angola, Ind.  
 Automobile Supply Mfg. Co., Brooklyn, New York.  
 The Batavia Rubber Co., Batavia, N. Y.  
 Double Fabric Tire Co., Auburn, Ind.  
 Voorhees Rubber Mfg. Co., Jersey City, New Jersey.  
 Wolverine Lubricants Co., New York City.  
 The Start-Lite Co., Chicago, Ill.  
 Gabriel Horn Mfg. Co., Cleveland, Ohio.

#### Mechanics' Hall, Boston, for Both Weeks

Ajax-Grieb Rubber Co., New York, N. Y.  
 The Baldwin Chain & Mfg. Co., Worcester, Mass.  
 Bosch Magneto Co., New York, N. Y.  
 S. F. Bowser & Co., Fort Wayne, Ind.  
 Coes Wrench Co., Worcester, Mass.  
 Columbia Lubricants Co., of New York, New York, N. Y.  
 Consolidated Rubber Tire Co., New York, N. Y.  
 Continental Caoutchouc Co., New York, N. Y.  
 The Wm. Cramp & Sons Ship & Engine Building Co., Philadelphia, Pa.  
 The Dean Electric Co., Elyria, Ohio.  
 The Diamond Rubber Co., Akron, Ohio.  
 The Electric Storage Battery Co., Philadelphia, Pa.  
 Empire Tire Co., Trenton, N. J.  
 Firestone Tire & Rubber Co., Akron, Ohio.  
 The Fisk Rubber Co., Chicopee Falls, Mass.  
 G & J Tire Co., Indianapolis, Ind.  
 The B. F. Goodrich Co., Akron, Ohio.  
 Gray & Davis, Amesbury, Mass.  
 A. W. Harris Oil Co., Providence, R. I.  
 The Hartford Rubber Works Co., Hartford, Conn.  
 Hartford Suspension Co., Jersey City, N. J.  
 The Hofferker Co., Boston, Mass.  
 The Jones Speedometer Co., New York, N. Y.  
 Leather Tire Goods Co., Niagara Falls, N. Y.  
 J. Ellwood Lee Co., Conshohocken, Pa.  
 Morgan & Wright, Detroit, Mich.  
 A. R. Mosler & Co., New York City.  
 The Motz Clincher Tire & Rubber Co., Akron, Ohio.  
 National Carbon Co., Cleveland, Ohio.  
 N. Y. & N. J. Lubricant Co., New York, N. Y.  
 Pennsylvania Rubber Co., Jeannette, Pa.  
 Remy Electric Co., Anderson, Ind.  
 C. F. Splitdorf, New York, N. Y.  
 Swinehart Tire & Rubber Co., Akron, Ohio.  
 Vacuum Oil Co., New York, N. Y.  
 The Veeder Mfg. Co., Hartford, Conn.  
 Federal Rubber Mfg. Co., Cudahy, Wis.  
 International Acheson Graphite Co., Niagara Falls, N. Y.  
 United Rim Co., Akron, Ohio.  
 Jacobson-Brandow Co., Pittsfield, Mass.  
 Goodyear Tire & Rubber Co., Akron, Ohio.

#### Mechanics' Hall, Boston, for First Week Only.

Allen Auto Specialty Co., New York, N. Y.  
 Apple Electric Co., Dayton, Ohio.  
 Auburn Auto-Pump Co., Boston, Mass.  
 Booth Demountable Rim Co., Detroit, Mich.  
 Borne, Strymser Co., New York, N. Y.  
 Champion Ignition Co., Flint, Mich.  
 Adam Cook's Sons, New York, N. Y.  
 Jos. Dixon Crucible Co., Jersey City, N. J.  
 Dorian Remountable Rim Co., New York, N. Y.  
 Dover Stamping & Mfg. Co., Cambridge, Mass.  
 Gabriel Horn Mfg. Co., Cleveland, Ohio.  
 Havoline Oil Co., New York, N. Y.  
 George A. Haws, New York, N. Y.  
 Heinze Electric Co., Lowell, Mass.  
 W. H. Leland & Co., Worcester, Mass.  
 Lovell-McConnell Mfg. Co., Newark, N. J.  
 Michelin Tire Co., Milltown, N. J.  
 National Coil Co., Lansing, Mich.  
 National Tuber Co., Pittsburg, Pa.  
 Oliver Mfg. Co., Chicago, Ill.  
 The Pantasote Co., New York, N. Y.  
 Pittsfield Spark Coil Co., Dalton, Mass.  
 The Republic Rubber Co., Youngstown, Ohio.  
 Wm. C. Robinson & Son Co., Baltimore, Md.  
 C. A. Shaler Co., Waupun, Wis.  
 Stromberg Motor Devices Co., Chicago, Ill.  
 Valentine & Co., New York, N. Y.  
 Vesta Accumulator Co., Chicago, Ill.  
 Warner Gear Co., Muncie, Ind.  
 Werner Instrument Co., Beloit, Wis.  
 Weed Chain Tire Grip Co., New York, N. Y.  
 The White & Bagley Co., Worcester, Mass.  
 Detroit Electric Appliance Co., Detroit, Mich.  
 The G. Piel Co., New York, N. Y.  
 The Esterline Co., Lafayette, Ind.  
 The Batavia Rubber Co., Batavia, N. Y.  
 Voorhees Rubber Mfg. Co., Jersey City, N. J.  
 Wolverine Lubricants Co., New York City.  
 The Connecticut Telephone & Electric Co., Meriden, Conn.

#### Madison Square Garden, for Second Week Only.

Ross Gear & Tool Co., Lafayette, Ind.  
 Standard Roller Bearing Co., Philadelphia, Pa.  
 Whitney Mfg. Co., Hartford, Conn.

GUSTAVE GOBRON, head of the Société Gobron-Brillie, and for many years a leader in automobile circles in France, is dead. He was born in 1846 and received high honors during his life. He was chevalier of the Legion of Honor.

ALBANY, N. Y., Oct. 9—William H. Catlin, state superintendent of roads, died recently. Col. Catlin had been at the head of the New York road department only a short time, but during his brief administration made many improvements.

# Big Entry List for Santa Monica

LOS ANGELES, Oct. 6—Forty cars are promised to start in the four events to be run in the third annual road races at Santa Monica on Saturday, October 14. This is the largest entry list ever gotten together for any western road race. The course has been put in excellent shape and the drivers expect to see a new record set for the course, which has proven to be the fastest in America.

Three of the four events will be classified by piston displacement only, all of the events will be non-stock.

In the free-for-all, which will be twenty-four laps of the 8.417 mile course, some of the fastest cars in America will be contenders.

Heading the entry list is a Fiat 90, driven by Teddy Tetzlaff, who set a new American record on the course last year with a Lozier averaging 73.27 miles per hour. Harris Hanshue, who won the first Santa Monica race with an Apperson, will pilot a Mercer.

Bert Dingley has purchased and entered the Pope-Hartford that he drove into first place this year in the Oakland-Portola road race.

Harvey Herrick will pilot a National. Herrick won the Los Angeles to Phoenix road race of nearly 500 miles last year with a Kissel.

Another of the local Western drivers that will be well placed in this race is Joe Nickrent, who has joined forces with the Marmon team.

These Western boys will have to compete with Wilcox and his National, Joe Dawson, Bill Endicott and Cyrus Patschke of the Marmon team, Disbrow and his Ohio, T. S. Duby and the Midland six, Dave Lewis on the Stutz and Harry Endicott, with the Inter-state.

The National team will have Merz and Aiken in reserve to be used if necessary. Ray Harroun will be here as manager of the Marmon team and may decide to take the wheel of one of the cars himself. The heavy car class with its minimum limit of 301 inches and the medium class running from 231 to 300 will be run simultaneously. The distance will be 151 miles or eighteen laps of the course.

There are four entries so far in the heavy car class most of the drivers preferring to hold out for the free-for-all with its larger purse and finer trophy.

In the 300 and under class will be entered two Coles with Johnny Jenkins and Frank Siefert driving. Hanshue will pilot the Mercer, Joe Nickrent and Bill Endicott will have Marmons. Louis Nickrent will handle the Buick, C. E. Bigelow will pilot the Lexington, McKeague who drove the Durocar into first place in this class last year will try to repeat his winning. A Schacht and a Parry are promised but no drivers nominated as yet.

In the mosquito fleet, limited to 230 inches, the line-up will consist of the Maxwell that won last year, with Clarence Smith driving. Smith purchased the car and is entering it himself. Frank Charle will drive a Ford, Frank Siefert a Paige-Detroit, Louis Nickrent a Buick, and Anthony a Regal. Hanshue will be in this event also at the wheel of a Reo. This will give Hanshue 450 miles to go to finish in all of the three events in which he has entered. A Flanders and an E-M-F promised will complete the list for the midgets.

Bert Dingley, Frank Siefert, Joe Nickrent and Harvey Herrick are each entered in two out of the three races.

The course will be open for early morning practice to-morrow. The National team is here and has established a camp at Santa Monica, and will be out early to get the cars tuned up.

A number of the cars are ready for the final road tests and the coming week will see the residents along the course among

the list of early risers whether it will be from choice or not.

Four big silver trophies are offered. The perpetual challenge cup given by Dick Ferris will go to the winner of the free-for-all. Leon T. Shettler's trophy will go to the winner in the heavy car class while two new trophies offered by Chanslor & Lyon and J. A. Jepson will go to the winners in the medium and light car class respectively.

In addition to the trophies over \$10,000 in cash will be divided among the cars that run in the money. Part of the cash prizes are offered by tire and ignition firms and only cars carrying their equipment are eligible for that part of the purse. Races run over the Santa Monica course in former years have been productive of notable contests. The course is acknowledged to be one of the fastest and safest in the United States.

## Colby Star Performer at Omaha

OMAHA, NEB., Oct. 9—The rain has proved the most consistent winner in the automobile races at the Omaha Speedway. The races were originally scheduled for September 30 and October 1, 2 and 4. They had to be postponed twice, but finally the first day's events were pulled off Wednesday, October 4. The second day's races were to have been held Friday, but again the rain interfered.

Pierce in a Colby carried off every contest he was allowed to enter on Wednesday in some of the fastest racing ever witnessed on this track.

In the 10-mile race for cars under 231 cubic inches displacement the Firestone-Columbus and Abbott-Detroit fought for first place throughout, the former winning by a quarter of a second.

In the first race the Colby was followed closely by the Firestone-Columbus and the Abbott-Detroit, but won the last easily. In a speed trial the Colby did 5 miles in 4:48. Following are the summaries:

10 Miles. 301 Cubic Inches Displacement or under			
Position.	Car.	Driver.	Time.
1.	Colby	William Pierce	10:09
2.	Firestone-Columbus	Ed. Rickenbacher	.....
3.	Chalmers	William Bruner	.....
10 Miles. Under 231 Cubic Inches Displacement			
1.	Firestone-Columbus	Rickenbacher	11:47½
2.	Abbott-Detroit	Smith	11:48
3.	Chalmers	Bruner	.....
4.	Paige-Detroit		withdrawn
25 Mile Free-for-All for Speedway Cup			
1.	Colby	Pierce	24:52½
2.	Firestone-Columbus	Rickenbacher	.....
3.	Abbott-Detroit	Smith	.....
4.	Paige-Detroit		withdrawn in fifth lap

## Second Day

OMAHA, Oct. 10—The races in Omaha had to be postponed again until Sunday. Pierce in his Colby 40 again carried off the honor, winning the Speedway cup. Summary:

50-Mile Free-for-All			
Position.	Car.	Driver.	Time.
1	Colby	Pierce	48:45½
2	Cutting	Ernest Delaney	70:23
3	Firestone-Columbus	withdrew, end of 45th mile.	
4	Mercer	Baker	Withdraw
5-Mile Speed Trials			
1	Colby	Pierce	4:44
2	Cutting	Delaney	5:21½
3	Firestone-Columbus	Rickenbacher	5:24½
Obstacle Race, 10 Miles			
1	Mercer	Baker	19:09½
2	Chalmers	Bruner	

# Truck Wheel Standards Extended

**A**T the meeting of the Division on Wheel Dimensions and Fastenings for Tires of the Standards Committee of the Society of Automobile Engineers held at the office of the society, 1451 Broadway, New York City, on Oct. 5 the following were in attendance: S. A. E. committee, W. P. Kennedy, chairman; C. L. Schwarz, E. R. Whitney, C. B. Whittelsey, J. A. Anglada and Coker F. Clarkson, secretary. Those representing the tire companies included H. W. Dupuy, Polack Tyre Company; A. Hauschild, Polack Tyre Company; E. R. Hall, Goodyear Tire & Rubber Company; W. H. Allen, The B. F. Goodrich Company; P. A. Aspell, The B. F. Goodrich Company; John C. Cole, Fisk Rubber Company; B. C. Swinehart, Republic Rubber Company; W. W. Wuchter, Swinehart Tire & Rubber Company; C. A. Swinehart, Swinehart Tire & Rubber Company; A. A. Brewster, Diamond Rubber Company; F. F. Phillips, U. S. Tire Company; J. L. Gibney, James L. Gibney & Bro.; J. W. Thomas, Firestone Tire & Rubber Company; S. G. Carschuff, Firestone Tire & Rubber Company; B. C. Swander, Firestone Tire & Rubber Company; E. Roberts, Kelly-Springfield.

The first subject taken up was the matter of a standard bolt hole circle for the flange type of solid motor tire. It was the sense of the meeting that the S. A. E. committee be requested to recommend the adoption of 1-2 inch as the diameter of through bolts for all sizes of solid motor tires.

Also that the diameter of the bolt hole circle for 36-inch tires should be 28 1-2 inches, and increase or decrease by even 2 inches for tires larger or smaller than 36 inches.

As to the number of bolts to be used, it was the sense of the meeting that for tires up to and including 36 inches diameter there should be 8, 12 or 24 bolts equally spaced where required; for tires above 36 inches and up to and including 42 inches there should be 10, 15 or 30 bolts equally spaced where required; for tires above 42 inches and up to and including 48 inches there should be 12, 18 or 36 bolts equally spaced where required and for tires above 48 inches and up to and including 54 inches there

should be 14, 21 or 42 bolts equally spaced where required.

It was voted that the manufacturers of commercial motor vehicles should be requested to inspect wheels which they purchase according to S. A. E. standards and to mark the same with a symbol visible at all times in the life of the wheels.

William E. Metzger, president of the National Association of Automobile Manufacturers, expressed the gratification of the manufacturers as to the S. A. E. standardization work and the belief that they would fully support the particular standardization under consideration at this meeting, namely the truck wheel having a constant diameter for all widths of solid motor tires of a given diameter, and a permanent metal band of 1-4 inch thickness for some sizes and 3-8 inch for others, the idea being that this metal band should never be removed from the wheel under any circumstances, but remain as the common basic point from which all the makers of solid tires are to work, all special steel equipment necessary to the application of the respective makes of solid tires being attached to the outside of this permanent metal band.

The society has just announced the details of the S. A. E. screw standard which supplants the A. L. A. M. screw standard, which was adopted by the Association of Licensed Automobile Manufacturers in April, 1906. The standardizing of nuts and bolts was a work of such magnitude and far-reaching usefulness that it may well constitute an enduring monument. It was work akin to bringing order out of chaos. The standard was an almost immediate mechanical success, the good results being felt not more by manufacturers than by dealers and drivers.

The only changes which have been made by the S. A. E. in the old standard are as to the distance across flats of the heads and nuts of the 1-4, 7-16 and 3-4-inch screws, the changes being from 3-8 to 7-16, from 11-16 to 5-8 and from 11-8 to 11-16 inch respectively. The A. L. A. M. screw standard did not go beyond 1-inch diameter screw. The S. A. E. standard proceeds by 1-8 and including 1 1-2-inch diameter screw.

## Calendar of Coming Events

### Shows

- Oct. 7-14.....Chicago, Ill., Show of Chicago Automobile Trade Association.
- Jan. 6-13.....New York City, Madison Square Garden, Twelfth Annual Show, Pleasure Car Division, Automobile Board of Trade.
- Jan. 6-20.....New York City, Madison Square Garden, Annual Show, Motor and Accessory Manufacturers.
- Jan. 10-17.....New York City, Grand Central Palace, Twelfth Annual Show, National Association of Automobile Manufacturers; also Motor and Accessory Manufacturers.
- Jan. 15-20.....New York City, Madison Square Garden, Twelfth Annual Show, Commercial Division, Automobile Board of Trade.
- Jan. 27-Feb. 10....Chicago Coliseum, Eleventh Annual Automobile Show under the auspices of the National Association of Automobile Manufacturers. Pleasure cars, first week. Commercial vehicles, second week.
- Feb. 14-17.....Grand Rapids, Mich., Third Annual Show.
- Feb. 19-24.....Hartford, Conn., Annual Show, Automobile Club of Hartford, State Armory.
- Week Feb. 22.....Cincinnati, O., Annual Show, Cincinnati Automobile Dealers' Association.
- March 2-9.....Boston, Mass., Tenth Annual Show, Boston Automobile Dealers' Association, Inc.

### Meetings, Etc.

- Nov. 20-24.....Richmond, Va., First American Road Congress, under auspices of American Association for Highway Improvement.
- Nov. 23.....Road Users' Day, under direction of Touring Club of America.
- Jan. 18-20.....New York City, Annual Meeting of the Society of Automobile Engineers.

### Race Meets, Runs, Hill-Climbs, Etc.

- Oct. 9-13.....Denver, Colo., Reliability Run, Denver Motor Club.
- Oct. 11-18.....San Francisco, Cal., Reliability Run, Good Roads Assn. of Northern California.
- Oct. 13-14.....Peoria, Ill., Track Races, Peoria National Implement and Vehicle Show.
- Oct. 14.....Santa Monica, Cal., Road Races.
- Oct. 14 (to 26)....New York City, Start of the Annual Glidden Tour, en route for Jacksonville, Fla.
- Oct. 30.....Minneapolis, Minn., Hill Climb.
- Oct. 20-21.....Sioux City, Iowa, Track Races, Sioux City Automobile Club.
- Oct. 21.....Atlanta, Ga., Track Races.
- Oct. 21.....White Plains, N. Y., Track Races, Westchester Driving Club.
- Oct. 27-Nov. 3....Chicago, Ill., Thousand-Mile Reliability Run, Chicago Motor Club.
- Oct. 28.....Newark, N. J., Reliability Run, Newark Motor Club.
- Oct. 30.....Harrisburg, Pa., Economy Run, Motor Club of Harrisburg.
- Oct. 31.....Shreveport, La., Track Races, Shreveport Automobile Club.
- Nov. 2-4.....Philadelphia, Reliability Run, Quaker City Motor Club.
- Nov. 3-4.....Columbia, S. C., Track Races, Automobile Club of Columbia.
- Nov. 4-6.....Los Angeles-Phoenix Road Race, Maricopa Auto Club.
- Nov. 9.....Phoenix, Ariz., Track Races, Maricopa Automobile Club.
- Nov. 9, 10, 12....San Antonio, Tex., Track Races, San Antonio Auto Club.
- Nov. 27.....Savannah, Ga., Vanderbilt Cup Race, Savannah Automobile Club.
- Nov. 30.....Los Angeles, Cal., Track Races, Motordrome.
- Nov. 30.....Savannah, Ga., Grand Prize Race, Savannah Automobile Club.

# THE AUTOMOBILE

Vol. XXV

Thursday, October 12, 1911

No. 15

## THE CLASS JOURNAL COMPANY

H. M. SWETLAND, President

CONDE NAST, Vice-President and General Manager

E. M. COREY, Secretary and Treasurer

231-241 West 39th Street, New York City

Cable Address - - - - - Autoland, New York  
 Long Distance Telephone - - - - - 2046 Bryant, New York

### SUBSCRIPTION RATES

United States and Mexico - - - - - One Year, \$3.00  
 Other Countries in Postal Union, including Canada - - - - - One Year, 5.00  
 To Subscribers—Do not send money by ordinary mail. Remit by Draft,  
 Post-Office or Express Money Order, or Register your letter.

Entered at New York, N. Y., as second-class matter.

The Automobile is a consolidation of The Automobile (monthly) and the Motor Review (weekly), May, 1902, Dealer and Repairman (monthly), October, 1903, and the Automobile Magazine (monthly), July, 1907.

## Comfort Is Essential

**A**UTOMOBILE buyers are looking for comfort in the cars they are going to purchase for the coming year. Two or more years ago the buyer did not give comfort much thought; he was glad to get a car in those halcyon days and it was of more concern to him to get a car with a good motor, a good gearset and a good running gear than one with special body comforts. To-day the situation is different. The majority of the buyers acknowledge that there are over two-score cars in which the motors are so well made that they will give all that is demanded in the matter of satisfaction; there are to-day two-score or more cars in which the gearsets and axles meet the expectations of the most fastidious; but there are not so many cars to-day that give everything that is asked for in the way of easy riding. Easy riding and comfortable seats with comfortable foot room are factors that will sell cars for 1912. Take two cars of equal reputation for stability in the motor, clutch, gearset and axles, that car with the better body suspension, with the better upholstery and with the more foot-and-leg comforts will prove the better seller. Some makers have grasped this idea already; they are up to date; others will grasp it when they have allowed the rival to get the benefit of the early bird.

It is natural that good spring suspension should be a factor in determining which automobile is to be purchased. It is natural that the woman who has to ride in the tonneau should instruct her husband to purchase the car that is the more comfortable to ride in. Not a few sales of 1912 cars have been clinched by the verdict of the tonneau should instruct her husband to purchase the motor of one may be better than that of another: the magneto on one may have some advantages over that of the other; but to the rear-seat passenger the comfort factor is one that cannot be overlooked. It is a prime consideration in the matter of selling cars; it is so important in these days when real salesmanship is needed that those concerns whose cars have stiff springs and uncomfortable seats will discover that it is time to use good springs, good upholstery and other body comforts.

The automobile manufacturer must wrestle with the matter of passenger comfort. Some are doing it to-day, but they have not succeeded as well as others. Naturally the first offered solution is that of fitting shock absorbers. This is a good solution providing the shock absorber is suited to the car load, and further provided that the absorber is kept in proper adjustment. But a shock absorber adjusted to a three-passenger load in a big touring car will not act well if seven or eight adults are in the machine; on the other hand, when the shock absorber is adjusted to a load of seven people the car suspension will not be the best when there is one lone person in the back seat. A simple solution would be the fitting of a device to the shock absorber that would allow of very quickly changing the adjustment to suit the different loads; but what driver would think of making the adjustment? Such an adjustment should be made before going on long cross-country trips.

The final solution of the problem is an engineering one. It is not always the shock absorber and it is not always the set of springs; the general design of the car plays its part. Every car owner has ridden in automobiles that will hold the road perfectly at fairly high speeds, whereas others at the same speed will be jumping all over the road. The reason is at hand: One is a well-balanced car, the other one is poorly balanced. The well-balanced car, if it holds the road perfectly, must of necessity ride more easily. It may not have much better springs than the poorly-balanced car, it may not have any better shock absorbers, but still it is a more comfortable car; it is a better-balanced car.

The matter of balance is attracting the attention of engineers to-day, but they do not know enough about the other engineer's car to pick out the bad points in their own. There is a solution, at least there is a way of bringing to the attention of the engineers that matter of suspension, and that is a contest in which suspension will be featured. In the early days of the automobile, when the cars were not properly braked, it was the reliability runs over the mountainous roads that impressed on the makers the necessity of more and better braking surface; when fenders were not strong enough to withstand continuous rough road usage it was the technical examination at the end of the endurance run that impressed it on the engineer; and to-day there is not any reason why a test on suspension would not serve to inform the engineer of the exact status of the suspension of his car. Such a test would not be a difficult one. It would require the attachment of some form of pointer, or needle, to the car axle and another needle to the car frame. Both should trace their up-and-down movement, or vibration, on a chart. All of the contesting cars would be fitted with the same device, which could be so designed as to be readily attached to any car. With a device of this nature in place, all of the contesting cars, with required load, would have to drive at different speeds over a certain surface, which might contain such road irregularities as street car crossings, cross ridge, cross rut and other holes. The tracings of the pointers on the chart would tell the story. There would not be any chance for deception in such a contest. The expertness of the driver would be a factor as it is in any form of contest, but in spite of this the test would be a really practical one. It would be an eye-opener to a good few makers. It would be a car seller to the concerns that had a good suspension.

There are some body comforts which are factors in making car sales, which call for immediate attention. It is a certainty that some of the engineers would never have made the clutch and service brake pedals so high if they had driven the car for an entire day. In others the sloping part of the floor boards in front is too short to accommodate the foot without the toe of the shoe rubbing against the highly-finished mahogany dash. The dash is soon disfigured. A little common sense would have remedied this before the car left the designing department. On some cars it is impossible for one person

to ride with any degree of comfort in the tonneau seat. Instead of there being a comfortable rearward slope to the upholstery, there is a forward slope tending to throw the passenger ahead. At other times the foot rail is either too far away or too near, and without any means of adjustment. The lack of body comforts could be enlarged upon, but it is not necessary. It is becoming more and more a necessity and the time is at hand when body comforts will be perhaps more of a selling factor than the particular make of carbureter, magneto or axle used. It is a field to which makers should give attention.

## Twenty Three-Car Teams in Glidden

**S**HARPLY at 9 o'clock Saturday morning, the touring column of the 1911 Glidden Tour will start from Fifth avenue and Thirty-ninth street on its journey to Jacksonville, Fla. The procession will be headed by a platoon of mounted police, behind which will be ranged 82 automobiles. Of this number 72 will be contestants for the Glidden Trophy or for the individual trophy offered by the city of Anderson, S. C.

Arrangements have been made with the State of New Jersey for touring privileges. For a time this phase of the tour looked dark as the officials of the State said that they wanted a full yearly touring license from each entrant and official car for the privilege of passing through the sacred precincts. This rule was later modified for the sake of general results and the tourists will not be required to take out licenses for a year.

The course will be across the Cortland street ferry, where the cars will be officially checked out. From there the route carries the party through Jersey City and Newark, reaching Philadelphia late in the afternoon.

Any State license carried by automobiles in the column will be good everywhere else that the route touches. In Virginia the cars will have to bow to the mediæval toll-gate regulations and it is understood that the rates have been raised down through the Old Dominion on the broad general ground that times are hard.

There will be approximately twenty three-car teams contesting for the Glidden Trophy. The other dozen cars will go along for the individual prize.

The teams so far as they have been formed are as follows: Atlanta Team 1: Flanders 8, C. S. Winn; Flanders 61, E-M-F Atlanta Company; Flanders 63, Decatur, Ga. Board of Trade.

Tarrytown team: Maxwells 1, 2 and 3, U. S. Motor Company.

Nashville team: Marathons 56, 57 and 58, entered by J. M. Downing, Dr. R. L. Dozier and Dr. Vernon Hutton.

Atlanta Journal team: Inman Gray, American 5; James R. Gray, Thomas 6; Maj. J. S. Cohen, White 7.

Waltham team: Metz 15, 16 and 17, Metz Company.

Albany, Ga., team: Halladays 34, 35 and 36, entered by D. P. DeBerry, C. E. Fryer and Streator Motor Car Company.

Atlanta team 2: C. H. Johnson, Stevens-Duryea, 11; Crawford Wheatley, Stevens-Duryea, 39; Brooks Morgan, Stevens-Duryea 66.

Detroit team: Flanders 53, 54 and 55, entered by the Studebaker Corporation.

Atlanta team 3: St. E. Massengale, Garford 18; L. C. Brown, Mitchel 19; Griffith Implement Company, Schacht 20.

Atlanta team 4: Fords 43, 44 and 45, entered by Carolina Portland Cement Company, E. M. Willingham and I. O. Teasley.

Atlanta team 5: E. P. Ansley, Pierce-Arrow, 10; B. M. Grant, Marmon, 12; E. Rivers, Pierce-Arrow, 64.

Atlanta team 6: Hoke Smith, Maxwell 4; William D. Alexander, White, 14; J. Epps Brown, Thomas 22.

Athens-Commerce team: C. J. Hood, Columbia, 24; Athens Motor Car Company, Columbia 49; Bishop and Varner, Maxwell, 50.

South Georgia team: W. E. Aycock, Moultrie, Knox, 25; Henry Tift, Tifton, Rambler, 38; Martin and Reese, Hahira, Cadillac, 59.

Ad Men's Club team: Atlanta Club, Corbin, 21; Anderson, S. C. Club, Mitchell; Greensboro Chamber of Commerce, Case, 71.

In addition to the foregoing there will be fifteen Florida cars, mostly Cadillacs which will be formed into five more teams. Some of the remaining individual entrants may team up with friends and acquaintances just before the column of automobiles is sent away.

### New A. B. of T. Committees Named

The new committees for the year were announced at the quarterly meeting of the members of the Automobile Board of Trade, held last week at the New York headquarters, 7 East Forty-second street. The new committees are as follows:

Patents—C. C. Hanch, W. H. Van Dervoort, L. H. Kittredge, A. Macauley.

Legislation and Law—G. H. Stilwell, Wm. B. Hoyt, Albert L. Pope.

Trade—H. O. Smith, E. R. Benson, W. E. Metzger, C. W. Churchill, W. T. White.

Intercourse and Arbitration—G. E. Daniels, W. C. Shepherd, J. W. Gilson.

Good Roads—R. D. Chapin, S. D. Waldon, J. N. Willys.

Statistical—Benj. Briscoe, E. P. Chalfant, J. S. Clarke.

Publicity—Alfred Reeves, E. R. Estep, H. W. Ford.

Show—George Pope, Alfred Reeves, M. L. Downs.

Mechanical Co-operation—A. L. Riker, D. Ferguson, F. B. Stearns, C. W. Nash, H. E. Coffin.

### Road Enthusiasts Will Tour to Richmond

Several road tours with Richmond, Va., as the objective point are being organized by good roads associations in various sections. The tours that are forming will be composed of those working for and interested in the good roads movement who purpose to attend the forthcoming convention of the American Road Congress at Richmond, November 20-24, under the auspices of the American Association for Highway Improvement.

The Touring Club of America reports that among the tours being projected are the following: From Quebec, under the direction of Howard D. Hadley, covering Canada, New England and New York; from Atlanta, under the leadership of Leonard Tufts, taking in a large part of the South and another tour from the Southwest, particularly reaching Tennessee.



## Electrics at the Palace

THE new Grand Central Palace opened its doors Wednesday to the Electric Exhibition. The main floor contained appliances for electrical cars, both pleasure and commercial, as well as for motors and other electrical devices. An opening lunch was given by the Edison Electric Company to the different exhibitors on the first floor, which afterwards is to be used as a demonstration ground for interested spectators to take trials of the vehicles. A model garage is being erected on this floor to show the latest improvements in the matter of fittings.

A goodly number of manufacturers of electrically propelled vehicles have taken space and are exhibiting different models of their manufacture. They have taken the situation in hand wholeheartedly and feel confident that in the field to which they particularly cater, viz., the town and suburban service, they are holding their own. The question of batteries, according to one prominent manufacturer, is no longer the bugbear to be overcome. These have been greatly perfected in the last few years so that it is now possible to cover a large area without recharging. With this and the improvements made in construction in general the mileage radius has been materially increased. Pneumatic tires are extensively used on pleasure cars, but the cushion type tire is favored by some, as it relieves the driver of all anxiety on this score, at the same time rendering the vehicle simple to handle—a great feature in cars intended for ladies' use.

The general characteristic features of the chassis and suspension of the gasoline car shows signs of being more closely followed and in the case of a few makers runabouts have been built resembling the gasoline runabout, with wheel steering and control on the wheel. Among these may be mentioned the Detroit electric and the Bailey. The makers of the latter have on exhibition a runabout that is capable of attaining a speed of 30 miles per hour and the identical car shown ran from Boston to New York in 12 hours' running time, averaging 20 miles per hour.

Shaft drive for the pleasure electric seems to be making converts and one maker who caters to both trades stated that he was selling many more shaft-driven electrics than the chain-driven variety. Practically every car on exhibition in the main hall was fitted with independent brakes operating on drums attached to the driving wheels, controlled by a pedal independent of the motor brake, which is operated by the control lever. Various types of control are shown and this part of the cars' mechanism seems to have been simplified.

A note struck by one manufacturer seems to be a possible solution of one of the difficulties at present in the minds of prospective buyers of commercial vehicles. Salesmen in their endeavor to make sales are not confining themselves to facts, and instead of coming out in the open and stating that the electric vehicle is primarily a town and short delivery vehicle are endeavoring to overestimate its value. Most of the makers are turning out at least one and in some cases two new models for the coming season. The general feeling is that when people become more educated to the possibilities of the electric that many more sales will result.

The Edison Company is placing two new batteries on the market similar in construction to the present type, but with larger capacity. They will be known as the A-10 and A-12 types, for 3 1-2 and 5-ton work respectively. The unit is comprised of 60 cells and the A-10 type has a 275 ampere-hour capacity, while the A-12 type has a capacity of 450 ampere-hour. The weight of each cell respectively is 32 and 29 pounds.

### Detroit in Week's News

DETROIT, MICH., Oct. 9—As a result of a movement now under way in the Detroit Board of Commerce, shipments of Detroit-made automobiles to South America and other foreign markets are likely to be very materially increased in the future. The first steps toward the organization of an export bureau, as an

adjunct of the board, were taken last week, when President Milton A. McRae pointed out the possibilities that await local manufacturers in many of the foreign markets, especially in South America.

The Elmore Automobile Company, 754 Woodward avenue, has taken the agency for the Reo.

In addition to the extensive improvements that are being made at its Detroit plants, the Studebaker Corporation is planning to add 40,000 square feet of floor space to its Windsor plant. The Dominion Stamping plant, which is a branch of a Detroit company, will also be enlarged.

The Harger Steam Truck Company, of New York, has been organized by several prominent Detroiters, headed by John S. Harger.

Rotary valve construction was the subject of an interesting discussion at the meeting of the Detroit chapter of the Society of Automobile Engineers, Friday evening.

### Bristol Scouts Reach Washington

RICHMOND, VA., Oct. 9—The highway scouts promoting the connecting link in the National Highway between Bristol, Tenn., Va., and Washington, D. C., met with rousing receptions at every stopping point and reached Washington to-day.

The scouting party left Bristol with five cars in line.

After attending the third annual meeting of the Appalachian Good Roads Association the scouts started on a tour of the Shenandoah Valley, on the way to Washington.

### Flanders Stars at Bedford Climb

INDIANAPOLIS, IND., Oct. 11—About 4,000 persons attended the hill climb held on Bright's Hill, Bedford, an 8 per cent grade. There were no serious accidents. Spectators were present from a radius of 100 miles and the climb was arranged by motor car interests of Bedford. A summary of events follows:

Cars of 230 Cubic Inches and Under			
Pos.	Car.	Driver	Time
1	Flanders "20"	Clayton Pierce	:53%
2	Flanders "20"	Frank B. Willis	
3	Buick	D. H. McCoy	
Cars of 231 to 350 Cubic Inches			
1	Marion	Ira Matthews	:47%
2	Westcott	John D. Glover	
Free-for-All			
1	Flanders "20"	Clayton Pierce	:42
2	National "40"	Ross McCoy	
3	Pope-Hartford	Frank Fox	

### Bad Weather Kills Danbury Meet

DANBURY, CONN., Oct. 7—The automobile races which were to be held in connection with the county fair here were called off by Secretary Schumaker, of the Contest Board of the A. A. A., owing to the slippery condition of the track following the rain.

The track is a half-mile dirt course of elliptic shape. The stretches are comparatively long, making sharp turns at either end of the ellipse. It was on this track that De Palma went through the fence two years ago and sustained a broken leg. Two other drivers went through the fence at the same spot last year. The track was in good condition when these accidents happened.

### Place and Show Money in Savannah Races

SAVANNAH, GA., Oct. 9—Additional purses for the placed cars in the Vanderbilt Cup, Tiedeman Trophy and Savannah Challenge Cup races have been hung up by the Savannah Automobile Club. In the Vanderbilt, a second prize of \$500 and a third prize of \$250 have been offered, while in each of the other races second money amounting to \$250 and third money of \$125 will be paid.

## Springfield Sees Races

SPRINGFIELD, ILL., Oct. 9.—The automobile races on Saturday, the closing date of the Illinois State Fair, served to draw out the largest crowd of the week.

The large crowd was only partially pleased with the meet, the close finishes which were staged and the lapping of cars at the grand stand being the only redeeming features of the exhibition.

There were only three real races in the entire card, the pursuit, the special race for the club championship and the 5-mile battle between the two Staver-Chicagos and the Case. All the others were flukes and failed to excite applause or appreciation.

McNay drove a great race in the Illinois Club championship, winning the \$600 trophy for the Springfield automobile club from Monckmeier in his Staver-Chicago, representing the Chicago Motor Club, after Wonderlick, representing Bloomington in a Buick, had dropped out in the second mile.

Heineman, driving a Case, defeated Monckmeier in the 5-mile race with Knudson, also in a Staver-Chicago, third. The summary:

Match Race, 2 Miles; Automobile Versus Aeroplane			
Car.	Driver	Position	Time
Marmon Wright-Biplane	Harroun	1	2:49 1/4
	Turpin	2	
Stock Cars, 2 Miles			
Staver-Chicago	Monckmeier	1	2:22
Staver-Chicago	Knudson	2	
Time of tire change, 54 1/2 seconds.			
Exhibition, 3 Miles with Tire Change			
Marmon	Harroun		3:28
Handicap, 3 Miles			
Marmon Case	Harroun	1	3:25
	Heineman	2	
Class C, 300 Inches and Under, 5 Miles			
Case Staver-Chicago Staver-Chicago	Heineman	1	5:38 1/4
	Monckmeier	2	
	Knudson	3	
Free-for-All, 3 Miles			
Mercedes Hotchkiss Benz	Burman	1	2:52 1/4
	Kilpatrick	2	
	McNay	3	
Illinois Club Championship			
Staver-Chicago Benz	McNay	1	10:21 1/2
	Monckmeier	2	
Free-for-All Handicap, 5 Miles			
Staver-Chicago Staver-Chicago Hotchkiss	Monckmeier	1	4:29
	Knudson	2	
	Kilpatrick	3	

## Bergdoll Won Fairmount

(Continued from page 611.)

cian must be carried over the full route except in case of illness. As the claim has not been advanced that Willoughby was taken suddenly ill, the referee had nothing else to do but to disqualify the car.

The appearance of the stands was somewhat different from last year. According to the new rules, the pits must be stationed at least 15 feet away from the nearest portion of the stands. As the Fairmount Park course is quite narrow at the place used for the official stands, it was found necessary to remove the pits to the west side of the main seats and entirely away from the view of the press and official quarters.

Thus, when a car signalled the pits from the upper end of the home stretch, it was with much difficulty that the newspapermen and officials could determine its identity until it started away again. There was very little mechanical difficulty experienced by the cars. The Fiat and Mercer No. 5 were the only ones to succumb to such. It was found functional trouble that put out the Cole, while the sole accident of the day fell to the lot of the Case. It was plain slowness and tire trouble that ailed the other losers. Only about half of the tire repairs were made at the pits, thus the impression was received that there was an abnormal lack of tire trouble for the Fairmount Park course.

This was not true, because the cars averaged about four changes during the running, but the changes were largely made out of range of the official stands.

Chairman Edwards was exceedingly active. Prior to the race he examined the cars, measuring the cylinders to establish their classes. He acted as assistant starter and during the race itself he maintained a kind of running inspection of the cars to insure against accidents that might happen as the result of neglected wear and damage.

At the finishing line he nodded to the starter to wave the various flags. Not once did he order the white flag used, signifying danger, but on two occasions he authorized the yellow signal which meant that the drivers must continue with caution.

One of these occasions was in the early part of the race when a car in making tire changes on the back stretch, failed to clear the whole width of the course. The yellow flags waved for two rounds, which probably caused several of the cars to lose ground as a result of obedience to orders. It was frequently remarked at the time that the warning was displayed too long, but on the other hand, no accident happened, as it might have done if the cars had been allowed to go over the course at full speed despite the partial obstruction of the track.

The officials all performed their duties with admirable precision and all are deserving of commendation.

The timing and scoring were excellently done. The mechanical timer worked splendidly and the Quaker City Timers' and Scorers' Club under the direction of President Paul B. Huyette checked and posted the lap scores with much celerity and exactness.

The score-board was divided into squares representing each lap and the elapsed time was painted into the squares after it had been announced by megaphone to the press and the grandstands.

A few errors were made, but these were corrected almost instantly and by the time the last car had finished, the complete standing of all the contestants had been posted in detail on the board.

### Best Laps at Fairmount Park

Fastest laps made by the cars in the Fairmount Park 200-mile road race. The length of the course is 8.1 miles according to survey and is not what is known as a fast course owing to the number of bends in its length.

Class 3-C				
No.	Car.	Lap.	Time.	M.P.H.
4	Cole	4	9 min. 20 sec.	52
5	Mercer	10	8 06	60
7	Case	10	8 24	57.8
11	Mercer	15	8 04	60.3
12	Ohio	6	8 51	55
19	Ohio	12	9 37	50.5
Class 4-C				
No.	Car.	Lap.	Time.	M.P.H.
6	National	9	8 min. 12 sec.	59.2
10	Stutz	12	8 38	56.2
16	National	12	8 01	60.6
Class 5-C				
No.	Car.	Lap.	Time.	M.P.H.
3	Lozier	25	7 min. 34 sec.	64.5
9	Lozier	19	8 00	60.8
12	National	23	7 43	63
17	Mercedes	25	7 41	63.3
18	Mercedes	8	8 10	59.5
Class 6-C				
No.	Car.	Lap.	Time.	M.P.H.
8	Benz	2	7 min. 28 sec.	65.5
15	Fiat	2	7 49	62

### Wishart Says He Will Take an Appeal

Spencer Wishart, driver of Mercedes 17 in the Fairmount Park road race decided Monday, has declared that he will file an appeal with the Contest Board against the ruling of Referee Dunlap which disqualified his mount after the car had finished first in Division 5C. Wishart has until Thursday night to perfect his appeal.



**SYRACUSE, N. Y.**—On September 30 foremen and assistant foremen of the H. H. Franklin Manufacturing Company held their annual clam bake at Pleasant Beach on Onondaga Lake, near Syracuse. Besides the clam dinner and the usual trimmings, baseball games and other impromptu sports helped make the day a very enjoyable one.

**COLUMBUS, OHIO**—The Charles Shiear Motor Car Company, Fourth and Spring streets, has taken the 1912 agency for the Hupmobile.

**OMAHA, NEB.**—The Auburn factory has just opened a branch here. W. T. Wilson will be the manager of the Omaha-Auburn Auto Company.

**INDIANAPOLIS, IND.**—O. H. Pearsall has been appointed general agent for Ideal motor trucks and has established quarters at 44 South Senate avenue.

**OMAHA, NEB.**—The E. R. Wilson Automobile Company has taken the agency for the Paige-Detroit car. The company at present handles the Lexington.

**OMAHA, NEB.**—The Marion Automobile Company has taken the agency for the Marmon cars. The company already has the Marion and Overland cars.

**COLUMBUS, OHIO**—O. G. Roberts & Company, 933 East Gay street, has closed contracts to handle the Marmon and Overland in nine counties in central Ohio for 1912.

**BOSTON, MASS.**—The S. G. V. agency is now located on Boylston street in the salesrooms formerly occupied by the Napier company, having moved from Ipswich street.

**CONCORD, N. H.**—The New Hampshire Automobile Company, of which W. E. Darrah is proprietor, has contracted to represent the Franklin Automobile Company this season.

**ELMIRA, N. Y.**—The Southern Tier Motor Company has been signed up by the Franklin Automobile Company as its representative in this locality. G. W. Shoemaker is president.

**HARTFORD, CONN.**—The Automobile Club of Hartford has undertaken the publication of a monthly magazine, to be known as *The Bulletin*. The magazine will make its initial appearance next month.

**WILMINGTON, DEL.**—The Bowe Carriage Company, of this city, has completed a fine automobile ambulance for the Phoenix Fire Company, which is ready for delivery and will be placed in service during the coming week.

**SYRACUSE, N. Y.**—A. A. Ledermann, formerly of Utica, has opened offices in the Rosenbloom building on South Salina street, where he will carry a full line of Pierce-Arrow automobiles and motor trucks.

**ANDERSON, IND.**—The Remy Electric Company has announced that \$400 will be given the drivers taking first, second and third places in the Los Angeles-Phoenix great desert road race, November 4 and 6, 1911.

**SYRACUSE, N. Y.**—W. E. Hookway has formed the Hookway Motor Truck Company to handle the Atterbury line and the Reliance. Mr. H. T. Windel, formerly salesman for the Buick, is manager of the company.

**GRAND RAPIDS, MICH.**—The Moran Auto Sales Company has moved from its old location on Kent street to 91 Jefferson avenue, the garage formerly operated by the Riley Auto Company, whose stock has been taken over.

**NEW YORK CITY**—Fred P. Nehrbas, formerly connected with the Thomas Motor Car Company, has become factory manager of the American Locomotive Company's

plant at Providence, where the Alco cars and Alco trucks are built.

**COLUMBUS, OHIO**—The Oscar S. Gear Automobile Company, 288 East Long street, has taken the agency in seven counties in Central Ohio for the Oldsmobile and Oakland for 1912. The Kelly truck will be represented in the same territory.

**COLUMBUS, OHIO**—The Cummins Auto Sales Company, 153-155 North Fourth street, has taken the central Ohio agency for the Elmore for 1912. Subagents have been contracted for as follows: Cambridge, E. O. Fogle; Thornville, D. S. Spangler.

**RICHMOND, IND.**—The following dealers have been given the agency for the Westcott line for 1912: Price Implement Company, Zanesville, Ohio; Ye Motor Shop, Connersville, Ind.; W. H. Miller, Champaign, Ill., and George J. Smith, Peoria, Ill.

**DETROIT, MICH.**—Joseph E. Warren has recently become connected with the Metzger Motor Car Company, of Detroit, manufacturers of the Everitt. Mr. Warren will be associated with Sales Manager Hood, in the capacity of chief of district managers.

**BOSTON, MASS.**—A 3-ton Board recently completed a 500-mile trip from Washington to this city in 4 1-2 days. The truck was finished just one day previous to the start of the trip. It carried 6,458 pounds of merchandise and ran on a schedule averaging 100 miles each day.

**COLUMBUS, OHIO**—The Reliance Truck & Garage Company, 111 East Lynn street, has closed contracts to handle all of the lines of the General Motors Truck Company, which will include electrics and gasoline trucks and delivery wagons. George Bohn is general manager.

**ATLANTA, GA.**—The Atlanta Automobile & Accessory Association held its annual

banquet on Tuesday last. Plans were discussed for the holding of races on the Atlanta Speedway the day the Glidden tourists are in Atlanta, October 23, but nothing definite was done.

**COLUMBUS, OHIO**—Kimmell Brothers, 215 North Fourth street, have taken the agency in this section for the Speedwell and Empire for 1912. Subagencies have been contracted for the Empire as follows: Point Pleasant, W. Va., Edward L. Felson; Dayton, Ohio, Baker & Weaver.

**PONTIAC, MICH.**—The contract for a combination automobile chemical and hose wagon to cost \$5,000 was awarded the American-LaFrance Company, of Elmira, N. Y., by the city commission. The wagon is to be built especially for the city's requirements and will be ready for delivery about the last of December.

**NEW YORK CITY**—William H. Chadwick has been appointed superintendent of the New York branch of the Locomobile Company of America. He will have entire charge of the mechanical and service departments. Mr. Chadwick was formerly with the Bosch Magneto Company, where he handled the repair and service departments.

**OMAHA, NEB.**—The dealers in Omaha took advantage of the Fall Ak-Sar-Ben carnival last week to have a garage show. All of the salesrooms were handsomely decorated, and special forms of displaying the cars were adopted. Automohile Row proved a rival to the street fair in attracting attention, and many cars were sold during the week.

**PHILADELPHIA**—Plans for a handsome two-story brick and terra cotta front clubhouse to cost in the neighborhood of \$100,000 are being prepared for the Automohile Club of Philadelphia. The new home of the organization will be located at the southeast corner of Twenty-third and Ludlow streets, having a frontage of 136 feet and a depth of 152 feet.

**FINDLEY, OHIO**—The work of taking an inventory of the Findley Motor Company's stock under the direction of Receiver John M. Barr has begun and will probably take ten days. Coupled with this fact comes the announcement that eastern stockholders of the company are working out a plan for reorganizing the company, and that the same will be promulgated shortly after an inventory is filed.

**WILKES-BARRE, PA.**—J. H. Fleming, proprietor of the City Hall Garage, has been selected to handle the Matheson "Silent Six" cars in Scranton and Lackawanna county, Pa. On Saturday, September 30, a dinner was served at the Hotel Jermyn to the officers of the Matheson company and their guests, after which a general demonstration of all the Matheson "Silent Six" models was made.

**MILWAUKEE, Wis.**—The Chamber of Commerce has purchased a Buick light delivery car for its weighing and inspection

department. Among the many advantages of motor service it has been found that with the truck samples of grain can be delivered on the floor of the chamber about one hour earlier than formerly, giving a big advantage to cash traders, to whom an hour a day is worth thousands.

**NORWALK, OHIO.**—The application for the transfer of the bankruptcy matter of the Norwalk Motor Car Company from Ben B. Wickham, referee for Huron county, to some other person on the ground that he is a stockholder in the company and an interested person, was acted upon favorably by Judge Killlets, at Toledo. The judge appointed Frank E. Seager, of Fremont, referee in bankruptcy for Sandusky county, to have charge of the matter.

**GRAND RAPIDS, MICH.**—Grand Rapids' Third Annual Automobile Show is scheduled for February 14-15-16-17, 1912. By the selection of these dates it will again be possible for exhibitors at the Chicago show to come directly to the Grand Rapids exposition. The show will be held either in the Klingman building, as heretofore, or in the new Coliseum. C. L. Merriman, of the Herald Publishing Company, will have charge of space allotments.

**TOLEDO, OHIO**—The big addition to the Willys-Overland Company's plant at Toledo is nearing completion. The new building is four stories high, 300 feet wide and 400 feet long and of concrete construction. It was expected that with the completion of this addition all Overland cars could be constructed in Toledo, but an announcement has been made that the concern has been forced by the volume of trade to continue operations at the Indianapolis plant.

**BUFFALO, N. Y.**—The local Automobile Trade Association gave Mr. Norman E. Oliver a farewell dinner at the Automobile clubhouse Saturday, September 30. Mr. Oliver has been manager of the Diamond Rubber Company, of Buffalo, for the past

ten years and has been promoted to secretary and general manager of the New York branch of the Diamond Rubber Company, which covers the States of New York, Pennsylvania and New Jersey.

**SIoux CITY, IA.**—A two-days' race meet will be held by the Sioux City Automobile Club October 20 and 21. Entries will close October 15. Each day there will be a 10-mile race for cars with a displacement of 161 to 230 inches, another for cars of 231 to 300 and a third for cars of 301 to 450. The first day there will be an Australian pursuit race and a 25-mile free-for-all. The second day there will be a 50-mile free-for-all. A total of \$1,525 in prizes has been offered.

**SYRACUSE, N. Y.**—From data received by the Automobile Club of Syracuse the estimate of the number of automobiles under operation in this country is given at 500,000, representing an estimated outlay of \$500,000,000. It is estimated that New York State has 50,000 machines. Pennsylvania is given second place, being accredited with from 40,000 to 50,000. Nevada and New Mexico are credited with the fewest number of automobiles, each having about 200 cars.

**LANSING, MICH.**—The Reo plant has resumed operations following the annual inventory. General Manager Richard H. Scott is authority for the statement that contracts with deposits have been closed for 10,243 cars to be delivered during the coming year, and he also states that the list of agencies has been increased 100 per cent. over that of last year. The report rendered at the annual stockholders' meeting of the company shows a surplus of \$1,250,000, with \$1,000,000 in cash on hand.

**LANSING, MICH.**—At the annual meeting of the board of directors of the Reo Motor Truck Company a 10 per cent. dividend was declared. During the past year certain parts of the truck have been manufactured



P. E. Sands and the Flanders "20," which won the "First to Hazelton" medal of the Pacific Highway Association, going 1,000 miles over a practically roadless country

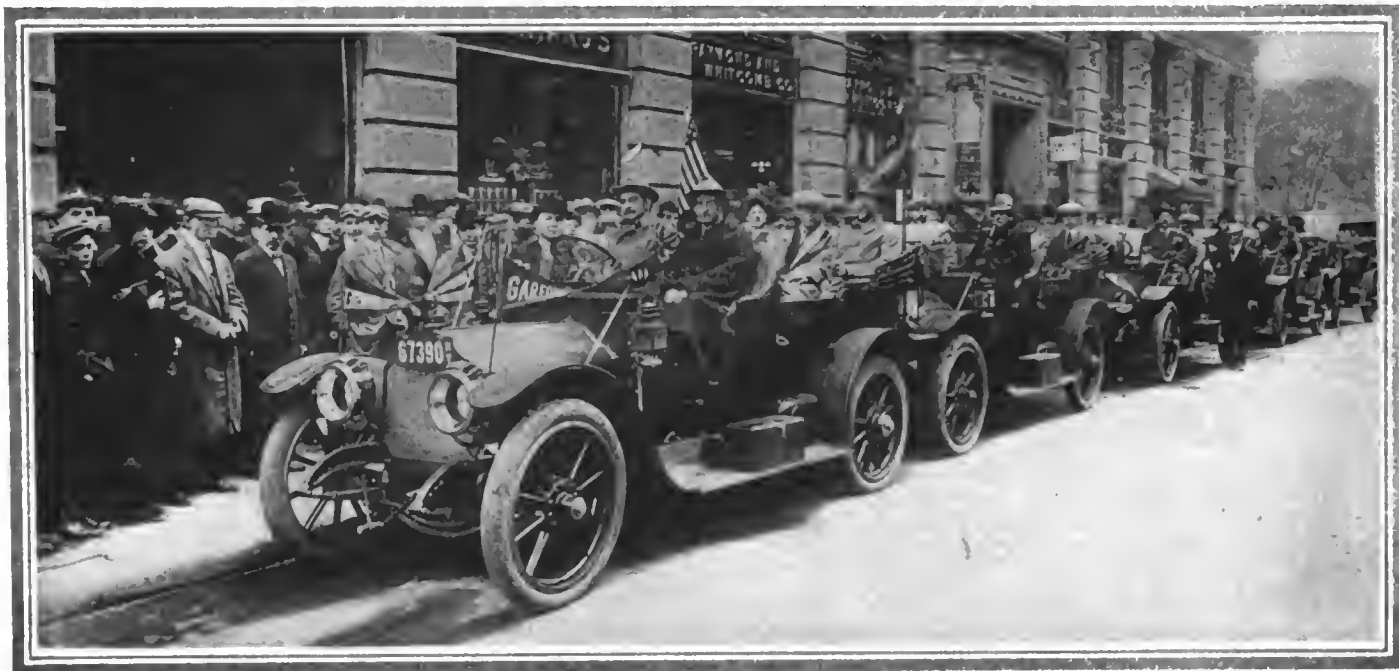

Line-up of Garford cars at New York before they started on the trans-continental trip under the auspices of a well-known tourist agency

at the Reo factory, while other parts have been built at the plant on South Grand avenue formerly occupied by the Bement company. Hereafter the entire truck will be constructed and assembled at the Grand avenue factory, and it is estimated that about 500 men will be employed in this branch.

**MINNEAPOLIS, MINN.**—The Baker Electric is to be handled here by M. L. Hughes and A. H. C. Dalley in the twin cities and the Northwest.

**KANSAS CITY, MO.**—The A. J. Davies company, distributors for the Knox and Chadwick cars has taken the agency for the Bergdoll car.

**PITTSBURGH, PA.**—Director Howard B. Oursler, of the Department of Supplies, has bought three more auto propelled combination chemical and hose trucks to be delivered December 1st.

**OKLAHOMA CITY, OKLA.**—Makers and dealers having failed to support the proposed reliability run under the management of the Oklahoma State Automobile Association, it has been decided to call the event off.

**MINNEAPOLIS, MINN.**—The date for the hill climb to be held under the auspices of the Minneapolis Motor Club has been definitely fixed for October 21, weather permitting. It will take place on the Columbia Heights hill.

**KANSAS CITY, MO.**—C. E. Christian has taken charge of the Hupmobile branch and has removed to 3013 Main street. The Hupp-Yeats Electric branch has removed to the large and handsome quarters formerly occupied by the Detroit Electric branch at 3501 Main street. W. N. McWade, of Detroit, is the manager of the local branch of the Hupp-Yeats concern.

**COLUMBUS, OHIO**—Ohio and Indiana E. M. F. and Flanders automobile dealers to the number of 150 left recently via the T. & O. C. Railway on a special train consisting of nine Pullman cars for a two days' outing at Detroit as the guests of the Studebaker Automobile Company. The Twyman Motor Car Company, Columbus, representatives of the Studebaker Corporation, sent eighty of their dealers on the trip. The party will visit the ten Studebaker plants in Detroit and neighboring towns.

**TOLEDO, OHIO**—Automobiles will be pressed into service by the United States Government at Toledo for the purpose of conveying mail carriers in the business district to the starting point of their routes, thus saving all annoying delays which might otherwise result when the postal business is housed in its new post office some distance from the business section. The auto service will be inaugurated as soon as the main office is changed to the new building, which will be within the next few weeks.

**INDIANAPOLIS, IND.**—The Rajah Auto Supply Company recently brought suit in the Federal Court in Indianapolis against George F. Kreitlein, operating under the name of the Guarantee Tire & Rubber Company and the Dealers' Auto Supply Company, alleging Kreitlein was manufacturing and selling a spark plug infringing on patents covering the Rajah plug. Kreitlein has filed an answer, denying the allegation and stating that no less than eleven brands of spark plugs are on the market which are similar to the type manufactured by the Rajah company.

**MILWAUKEE, WIS.**—Albert Smith, 169 West Water street, representative of the Palmer-Singer in this territory, and for

many years a well-known electrical man, died after a short illness, aged 48 years. Mr. Smith's death is attributed directly to a bantering wager with George Harvey, of Cleveland, Ohio, that he could drive from Milwaukee to Cleveland in two days' time without extra effort. With Mr. Harvey as a passenger, Mr. Smith easily won the wager in a two-passenger Palmer-Singer, but in doing so he contracted pneumonia, which resulted fatally within a week.

**WILMINGTON, DEL.**—A new law enacted by the General Assembly of Delaware this year for the protection of motor vehicles is to be given its first test at the November term of the court of General Sessions in and for New Castle county, in which Wilmington is located. This is a special law intended to put a stop to joy riding. For some time there had been a law on the statute books making it a punishable offense to drive off a horse without the consent of the owner, but automobilists had no such protection, but they have now and naturally there is some rejoicing. An arrest has recently been made and a test case will be tried.

**INDIANAPOLIS, IND.**—Judge Albert B. Anderson of the United States Circuit Court here has entered a decree enjoining Orion K. Stuart from obtaining empty Presto-O-Lite and Autogas tanks and refilling them for the purpose of putting them on the market. Judge Anderson has also referred the matter to Edward Daniels, master in chancery, who is to determine the amount of damages the Presto-O-Lite company has suffered by Stuart having filled such tanks. The decree also finds that the Autogas company has manufactured tanks infringing on the patents of the plaintiffs and that Stuart refilled tanks manufactured by the Autogas company.



## Automobile Incorporations

### AUTOMOBILES AND PARTS

ALEXANDRIA, VA.—B. F. Board Motor Truck Co.; capital, \$25,000; to make freight automobiles. Incorporators: B. F. Board, Douglas Stuart, W. E. Bain, George S. Hinkins.

BROOKLYN, N. Y.—Osgood Motor Car Co.; capital, \$10,000; to deal in automobiles. Incorporators: Samuel H. Misleind, Paul W. Smith, Irving J. Joseph.

BUFFALO, N. Y.—Baker Bros. Motor Co.; capital, \$10,000; to deal in motor cars. Incorporators: Edward A. Green, Edward H. Baker, Clarence W. Baker.

MONTREAL, CAN.—Dunnings Limited; capital, \$20,000; to deal in automobiles.

NOVATA, OKLA.—Nowata Motor Car Co.; capital, \$2,500; to sell automobiles. Incorporators: Walter K. Campbell, George Gordon, Stanley J. Campbell.

OAKLAND, CAL.—S. & D. Motor Vehicle Co.; capital, \$280,000; to deal in automobiles. Incorporators: B. E. Duckworth, A. A. Montague, Carlos Schmidt.

PEORIA, ILL.—Cadillac Automobile Co.; capital, \$5,000; to sell automobiles. Incorporators: Rollin Travis, Henry Numann, H. H. Moody.

PROVIDENCE, R. I.—Providence Motor Car Co.; capital, \$25,000; to deal in automobiles. Incorporators: John A. McDonald, Wm. H. McSoley, Alice Stanton.

RICHMOND, VA.—Grasberger Vehicle Co., Inc.; capital, \$50,000; to deal in pleasure and freight automobiles. Incorporators: J. A. Grasberger, J. F. Sorg, Robert N. Wildhore.

RICHMOND, VA.—Motor Truck Co.; capital, \$25,000; to sell freight automobiles. Incorporators: H. A. Gillis, Charles Laurens, T. M. Garrity, E. P. Cox.

### AUTOMOBILE GARAGES, ACCESSORIES,

BUFFALO, N. Y.—Buffalo Reliable Garage; capital, \$2,000; to conduct a general garage business. Incorporators: John J. Timmerman, Irving L. Carpenter, Charles H. Cutting.

BUFFALO, N. Y.—Kunz-Adams-McNamara Co.; capital, \$10,000. Incorporators: H. M. Adams, William Kunz, O. B. McNamara.

CLEVELAND, OHIO.—Richardson-Neighbors Motor Co.; capital, \$5,000; to sell accessories. Incorporators: F. E. Richardson, H. F. Neighbors, W. J. Dawley, Sidney Seidman, Stephen M. Young.

DAYTON, OHIO.—Acme Carbureter Co.; capital, \$10,000; to manufacture carbureters and other accessories. Incorporators: Chas. S. Barkeley, E. Leiber McCallay, Chas. C. Margerum, W. H. Johnson, Lester Corson.

DAYTON, OHIO.—Baker Taxicab Co.; capital, \$10,000; to operate a garage and taxi business. Incorporators: George L. Baker, Frank R. Baker, Harry W. Baker, John N. Van Deman, Chas. D. Heald.

ELMIRA, N. Y.—Heater-Muffler Co.; capital, \$50,000; to manufacture appliances for automobiles and engines. Incorporators: Wilber Kinzie, Lanson D. Curran, Ansel G. Ingham.

INDIANAPOLIS, IND.—Merchants Auto Co.; capital, \$50,000; to conduct a garage business. Incorporators: E. Darrow, Wm. E. Burk, Chas. S. Shotwell, H. H. Rice, C. L. Marshall, W. A. Atkins, Harvey B. Stout.

NEW YORK, N. Y.—Manhattan Top & Body Co.; capital, \$50,000; to manufacture automobile equipments. Incorporators: Guy B. Kadford, Herman Schuler, Chas. D. Heintze.

UTICA, N. Y.—Divine Tire Demonstrating Co.; capital, \$10,000. Incorporators: Bradford H. Divine, Edmund G. Munson, T. Harvey Ferris.

NEW YORK CITY—A. R. Mosler & Co., are erecting a new factory at the corner of Wakefield and Webster avenues, Wakefield Park, New York City. The new building is constructed of brick and concrete, 100 x 150 feet and is two stories high. Two hundred and fifty people will be employed.

INDIANAPOLIS, IND.—Another three-story reinforced concrete building is being added to Auto Row, in North Capitol avenue, by the Globe Realty Company. It will cost \$60,000 and will be completed February 1. The building will be occupied by the Henderson Motor Sales Company and the B. F. Goodrich Company's tire sales branch.

MINNEAPOLIS, MINN.—A show coliseum for Minneapolis, which is to be completed by next January in time for the automobile exhibition, was assured last Tuesday when the Board of Tax Levy appropriated \$25,000 for an annex to the National Guard Armory in this city. When completed the entire building will hold more than 9,000 people, and will have a floor space of 72,000 square feet.

SOUTH BEND, IND.—One of the first steps taken by the city to install motor vehicles in all the fire stations during the next few years has been taken by the City Council appropriating \$6,500 with which to purchase an automobile chemical engine. The Board of Safety has received specifications prepared by Fire Chief Wilfrid Grant, and will ask for a machine to conform to the plans of the chief.

MINNEAPOLIS, MINN.—On its return to the list of Minneapolis-sold cars the Marion makes its home with the new Marion Motor Car Company, 1027 Hennepin avenue. The company is officered by men old in the business. W. A. Crowe is president; W. A. Crowe, Jr., is vice-president; H. A. Crowe is secretary-treasurer. C. G. Wernicke, of Minneapolis, is sales manager.

BOSTON, MASS.—The Cork Insert Company announces that a reduction in the royalty charged for the right to use cork inserts in automobile clutches and brakes has been made. The royalty charged is now 90 cents on clutches transmitting less than 25 horsepower and \$1.25 on clutches transmitting 25 horsepower or more, and 50 cents per vehicle for brakes.

CINCINNATI, O.—The announcement is made here that the Kruse Motor Car Company will hereafter control the complete line of Maxwell bodies and chassis, for this city, contracts to that effect having been concluded, and arrangements made, to become operative at once. The first specimens of the 1912 Maxwell, will soon be on exhibit at the Kruse Ware-rooms, on Seventh avenue.

NEW HAVEN, CONN.—The White Motors Company, which sells White cars and trucks in Connecticut, until recently located at 666 State street, has opened a handsome office and salesroom at 1094 Chapel street, where a complete line of the White Company's

products will be carried. The officers are: P. R. Greist, president; H. M. Greist, treasurer, and W. A. Rutz, secretary and general manager.

RACINE, WIS.—The motor car department of the J. I. Case Threshing Machine Company has started construction work on a new building to replace a large frame structure situated between Twenty-third and Twenty-fourth streets.

PITTSFIELD, MASS.—The Cortland Motor Wagon Company has moved its plant from Cortland, N. Y., to this city, in order to secure better shipping facilities. The new plant has a floor space of 50,000 square feet, and while the machinery has not yet been completely installed the management expect to have the manufacture of 1500-pound and one-ton trucks under way within a week.

BOSTON, MASS.—George W. Houk, manager of the New England branch of the Oldsmobile Company, with headquarters in Boston, has resigned and his successor is W. B. Fewell. Mr. Houk has not decided on his future plans, but he is considering an offer to go to London to manage a branch there. He spent several years in England previous to coming to Boston two years ago.

MILWAUKEE, WIS.—Manufacturers of motor vehicles are granted the lowest rates of all in the list arranged by the Employers' Mutual Liability Insurance Company of Wisconsin, organized to insure manufacturers against the hazards of the new workingmen's compensation or industrial insurance act passed by the Wisconsin Legislature and now in force. The rate per \$100 of wages is fixed in a large number of cases and for motor manufacturers is 67 cents for Class A, 75 cents for Class B and 84 cents for Class C. The next lowest class pays 66 2-3 per cent. more.



Maxwell team which will represent Tarrytown, N. Y., in the Glidden tour—No. 1, Harry Walls; No. 2, E. G. Gager; No. 3, Thos. Costello

# OF INTEREST *to the* INDUSTRY



**KENOSHA, WIS.**—There left the Rambler factory on Tuesday, October 3, the flagbearer of the Rambler line for 1912, which is to be relayed through the East by representatives of that company in the various cities on the route. The car was manned on the first lap by Walter R. Simkin, of Chicago, and Al Reeke, of Milwaukee, who drove it to Chicago, where Webb Jay took the wheel. In the illustration Charles T. Jeffery, president of the Thomas B. Jeffery Company, is seen bidding the first crew Godspeed.

**BOSTON, MASS.**—George L. Cooke has been appointed manager of the local agency for the Morse car.

**BOSTON, MASS.**—Lin McKie has been given charge of the Velie truck sales and maintenance in the Boston territory.

**PHILADELPHIA**—The local agency of the Krit car, the Kline-Krit Company, has been moved to Nos. 1405-1407 Race street.

**BOSTON, MASS.**—W. Mason Turner will represent the Amplex car here. He has secured quarters at 261 Dartmouth street.

**COLUMBUS, OHIO**—F. E. Avery, 1199 Franklin avenue, has taken the central Ohio agency for the Packard and the Waverley Electric.

**ATLANTA, GA.**—The Velie Motor Company will soon open a branch in Atlanta. This company has secured a location at 447 Peachtree street.

**MONTREAL, CANADA**—The Motor Import of Canada, Ltd., have been appointed sales agents in the Province of Quebec for Pierce-Arrow motor cars.

**ATLANTA, GA.**—Hupp-Yeats Electrics and R. C. H. cars will soon be sold from their own branch in Atlanta, the new store at

Peachtree and North avenue being now nearly completed.

**INDIANAPOLIS, IND.**—A factory sales branch of the Auburn Automobile Company was opened at 518 North Capitol avenue on October 2, with F. P. Bellinger in charge as manager.

**BOSTON, MASS.**—The Nance Six is a newcomer to Boston motor circles and salesrooms for it have been opened at 94 Massachusetts avenue. It is being handled by the Motor Car Company, recently organized.

**MILWAUKEE, WIS.**—The Lozier Motor Sales Company, 197-199 Ogden avenue, State distributor for the Lozier, has been appointed agent for the Marion, which heretofore has been represented by George W. Browne, 460 Milwaukee street.

**BOSTON, MASS.**—The Teel Manufacturing Company, of Medford, one of the suburbs of Boston, a concern that has been building wagons and automobile tops for years, has embarked in the commercial truck field and is now manufacturing a 5-ton vehicle.

**KENOSHA, WIS.**—Frederick Purdy, for many years a foreman in the shops of the Thomas B. Jeffery Company, has purchased the interest of the Kent Brothers in the Kent Motor Car Company and will henceforth conduct the garage on Church street.

**GREEN BAY, WIS.**—Lawrence Kittell and Charles W. Collier have formed a partnership under the style of Fox River Motor Car Company and will handle the Ford in this territory. A garage and salesrooms have been opened at 510-512 South Monroe street.

**COLUMBUS, OHIO**—The Board of Education has purchased a motor car for the use

of Superintendent J. A. Shawan of the public schools. The car is to be at the disposal of the members of the Board of Education also when they are on official business.

**MONTREAL, CANADA**—The liquidators of the National Motor Car Company of Canada, Ltd., are calling for tenders for the sale of the business, which consists principally of stock in trade, furniture, fixtures, machinery and tools, the whole valued at \$3,971.24.

**MILWAUKEE, WIS.**—The Wisconsin Auto Sales Company has been appointed Wisconsin distributor for the National, Cutting, Herreshoff and Westcott cars. The company has temporary headquarters at 114 Mason street in the Colby-Abbott building.

**KANSAS CITY, MO.**—W. S. Hathaway, general supervisor for the United States Motor Company has decided to retire from the automobile business. Mr. Hathaway represented the Buick company in this city for four years and the United States Motor Company the same length of time.

**BOSTON, MASS.**—C. F. Whitney, who handles the Alco in Boston and who had the Stoddard-Dayton until a week ago, has vacated the quarters on Commonwealth avenue and has moved downtown to Boylston street in Copley square. The Alco plans to establish its own branch in Boston.

**PITTSBURGH, PA.**—The Universal Motor Truck Company, of Warren, Ohio, which was formed in Denver a few years ago, is considering a change of location. Its officials have been considering Fairmont, W. Va., as a new home for the plant, which will employ 500 skilled workmen.

**PITTSBURGH, PA.**—The Penn Motor Car Company, which established a plant about a year ago in the East End and in which A. G. Breitwieser, a wholesale lumberman of this city, is largely interested, has finally decided to locate its immense plant at New Castle, Pa., 30 miles north of here. It has secured 9 acres of ground, 4 of which will be covered with buildings, it is announced. The initial investment for building and machinery will be about \$350,000.

**HAMILTON, ONTARIO**—The Schacht Motor Company, of Cincinnati, Ohio, has purchased the plant of the Tilden-Jackson Typewriter Company, Hamilton, Ont., and has organized a Canadian company to manufacture commercial motor vehicles in Canada. The officers of the company are: President, Thomas P. Rolph, Toronto; vice-president, T. H. Schacht, Cincinnati; treasurer, Gerrard Muntz, Toronto; secretary and sales manager, J. S. Innes, Toronto.

# PATENTS GONE TO ISSUE

**CLUTCH MECHANISM**—Motion is transmitted by means of a plurality of friction surfaces.

2. In the clutch shown in Fig. 1 a driving member is mounted on a shaft and having friction bearing surfaces thereon, while a driven member longitudinally slidable along the same shaft is provided and locked against rotation relatively thereto. A friction shoe is longitudinally movable along the shaft, another friction shoe radially, and independent yielding means are interposed between the driven member and the two friction shoes, so that, when the driven member is moved longitudinally and radially of the shaft, the shoes may be moved longitudinally and radially of the shaft respectively, and forced against the friction bearing surfaces on the driving member with a yielding pressure.

No. 1,004,940—To Frederick A. Thurston, assignor of forty-eight one-hundredths to Henry Mayberry Jones, both of Lynn, Mass. Granted October 3, 1911; filed July 19, 1910.

**ACETYLENE GENERATOR**—A plant for generating acetylene gas.

The invention which is protected by this patent consists in the combination of a carbide holder with, and mounted on top of, a generating tank; from this holder a pivoted feed-shoe is suspended which normally tends to assume a non-dumping position. A gasometer bell is provided, also an actuating shaft for the feed shoe, the shaft having a crank on which a pivoted lever is pivotally mounted, the crank engaging a counterweighted hook. Pivoted lever and gasometer bell communicate through actuating connections, and there is provided on the carbide holder an interference device which, when moved to a position permitting the opening of the carbide holder, engages the counterweighted hook.

No. 1,004,909—to Paul A. Rose, Chicago, Ill., assignor to Acetylene Apparatus Mfg. Co., Chicago, Ill. Granted October 3, 1911; filed March 9, 1910.

**LIGHT PROJECTOR**—Containing a reflector and a Fresnel type of lens.

3. The patent relates to the combination (Fig. 2) of a casing and lamp with a lens of the Fresnel type. The inner edge of an outwardly flaring and reflecting hood meets and surrounds the operative face of the lens, and a glass is provided at the outer edge of the hood. The angle of the reflecting surface of the hood is such that the lights rays projected through the miters of the lens and caused by them to be diverged away from the axis of the beam are caught and reflected by this surface and collected into an approximately parallel beam.

No. 1,004,628—To William Churchill, Corning, N. Y., assignor to Corning Glass Works, Corning, N. Y. Granted October 3, 1911; filed September 14, 1910.

**PISTON RING**—Consisting of a packing ring and supplementary member.

4. This patent refers to the combination of a piston head, a face plate secured thereto (Fig. 3), a split packing ring and a supplemental packing member, the ring and member being located between the piston head and face plate. Means are provided to normally hold the packing member toward the cylinder wall on the side where the split is located in the ring, and also means to secure all the members against rotation.

No. 1,004,631—To Thomas Davis, Pittsburgh, Pa. Granted October 3, 1911; filed January 13, 1911.

**RUBBER TIRE**—Containing a plurality of resilient sections and an externally mounted retaining ring.

A greater number of the sections than normally required form a continuous circle of the diameter of the retaining ring, which holds the sections in a compressed state.

No. 1,004,642—To George H. Gillette, New York. Granted October 3, 1911; filed November 28, 1910.

**ELECTRIC WELDING**—Method of fixing a pin or rod to a plate.

The process consists in forming a countersink in the end of the pin or rod and one or more projections extending beyond the outer wall of the countersink and in uniting the pin or rod to the plate by an electric butt welding operation.

No. 1,004,795—To Laurence S. Lachman, New York, assignor to Universal Electric Welding Co., New York. Granted October 3, 1911; filed October 15, 1908.

**STEERING MECHANISM LOCK**—Toothed bars serve to hold steering knuckle in place.

In the device covered by this patent (Fig. 4) a toothed bar is fixed to the front axle of an automobile, and a movable toothed bar is connected to a steering knuckle. Means are provided to force the teeth of the two toothed bars into engagement, so that the movable bar is locked against movement under the influence of the steering knuckles to which it is connected.

No. 1,004,973—To George W. Benton, Finley, N. D. Granted October 3, 1911; filed January 26, 1911.

**PNEUMATIC TIRE RIM**—A rim having flanges overlapping and bolted to the felloe. The rim patented fits around a wheel felloe and has a portion of it beveled, the rim having a tire flange and another flange contacting with the felloe. A removable flanged ring fits the beveled portion of the rim and has a tire holding flange and a flange in contact with the felloe, bolts passing through the flanges contacting with the felloe and nuts being used to secure removable ring and beveled ring in place on the felloe. Lugs carried by the removable ring project over the flanged nuts.

No. 1,004,639—to Sylvester Cline Force, San Francisco, Cal. Granted October 3, 1911; filed January 6, 1910.

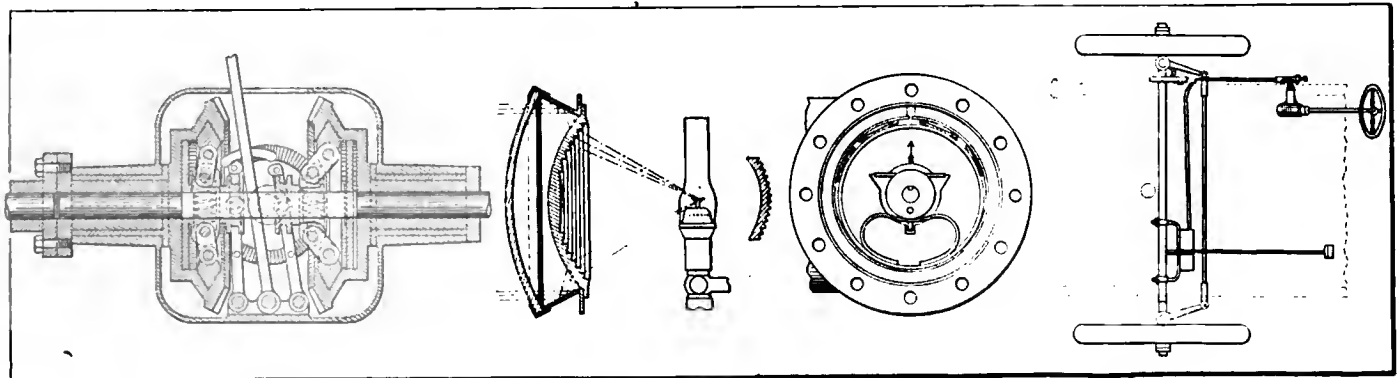

Fig. 1—Thurston clutch

Fig. 2—Churchill projector

Fig. 3—Davis piston ring

Fig. 4—Benton steering gear

# Newest Ideas Among the Accessories

## Speedo Air Valve

**S**PEEDO, shown in Figs. 1 and 2 serves to regulate the air supplied to the engine at all speeds or to feed finely divided kerosene to the motor, when the latter needs decarbonizing. The exterior appearance of the device is shown in Fig. 1, illustrating the manner of attaching the Speedo to the intake manifold of the motor.

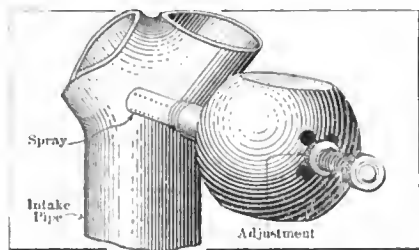

Fig. 1—Speedo auxiliary air supply on intake manifold

To install the Speedo it is necessary to drill a hole in the manifold at any suitable point above the carbureter and to tap it for 1-4-inch pipe thread.

After inserting the threaded stem of the Speedo in the opening made in the manifold, the nut marked for adjustment is loosened and the projecting stem of the device screwed inward as far as it may be advanced. It is necessary that in installing this accessory one flat side comes to the top position, so as to completely break up the gasoline molecules struck by the air entering the manifold from the Speedo.

The device having been installed, the engine is started and throttled down as low as possible; then the projecting stem is slowly screwed outward until the motor begins to pick up. At this point the retracting movement of the stem is stopped, the same is given a full turn in the inward direction and the adjustment nut locked tightly.

The Speedo now being ready for use, it will be well to examine Fig. 2 for an explanation of its operation. The casing is threaded at one end to fit into the manifold, twenty-eight holes being provided at that end of the stem, which is hollow and communicates with the inner space of the round portion of the Speedo. This portion is tapped to accommodate the projecting stem on which the air valve slides, the valve having an inner and an outer seating. If it falls on the latter, it covers up four holes serving as air intakes. The wall of the chamber in which the valve moves is tapered, so that as the valve is moved outward the space surrounding it increases.

The proper adjustment of the device insures a certain amount of spring tension,

which tends to draw the valve away from its inner seat. When the motor is throttled down, the suction through the Speedo is naturally a comparatively great one, but it only tends to seat the valve more securely. If, however, the throttle opening is increased, the suction through the device decreases and is finally overcome by the spring tension, which then lifts the valve off its seat and permits air to pass through the Speedo into the manifold. The air leaving the outlet pipe crosswise in relation to the mixture traveling toward the motor strikes the gasoline molecules with a maximum of strength and breaks them up into finer parts. The effect of the Speedo and the air supplied by it to the motor increase with the engine speed.

If the Speedo is to be used for removing the carbon accumulated in the engine cylinders, kerosene is injected through it into the manifold. In this case a small rubber tube furnished with the Speedo and carrying at one end a brass connection is screwed onto the end of the projecting stem, after the cap shown in Fig. 2 has been removed for the purpose. The other end of the tube is made to hang down into a vessel containing one pint of kerosene, and if the motor is started, the oil is drawn into the hollow projecting stem, atomized through the nozzle formed by the inner end of this stem and mixed with the charge flowing from the carbureter to the motor. One pint of oil applied twice a month will remove the carbon settling in the cylinders during this time. This device is made by the International Accessories Corporation, of New York, Chicago and Los Angeles.

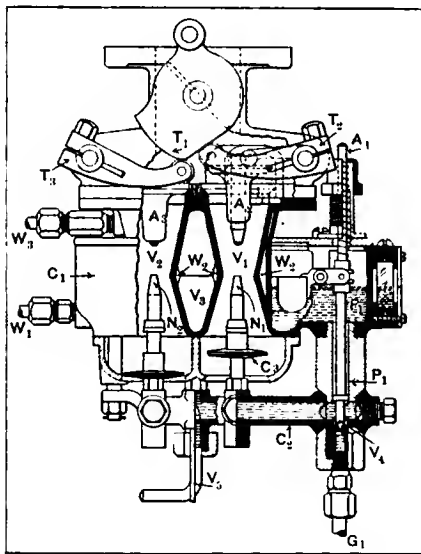

Fig. 2—Section showing details of C R G carbureter

## C R G Carbureter

The special feature of the C R G carbureter shown in Fig. 3 is the fact that use is made in it of three Venturi tubes which are assembled in one casing  $C_1$  of the carbureter. These Venturi tubes  $V_1$ ,  $V_2$  and  $V_3$  have a gasoline nozzle concentrically located in each of them, as shown at  $N_1$  and  $N_2$ , situated in  $V_1$  and

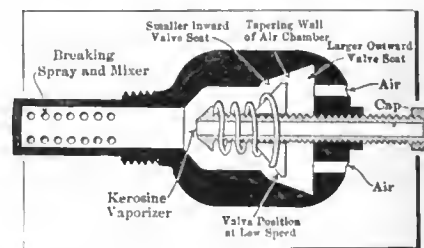

Fig. 2—Section showing principle of Speedo operation

$V_2$  respectively. The nozzles are screwed into the gasoline connection  $C_2$ . The gasoline enters at  $G_1$ , fills the space of the connection  $C_2$  and then rises through pipe  $P_1$  to the float chamber  $F_1$  which surrounds the Venturi tubes on all sides. The gasoline flow is regulated by the needle valve  $V_4$ , adjustable at  $A_1$ , and after rising to a certain level in the float chamber the gasoline flows back into  $C_2$  to the nozzles, lifting the clappet valve  $C_3$  from its seating and permitting the fuel to flow into Venturi tube  $V_1$ . The air is supplied through the seats of the clappet valves, when these are lifted through the suction of the motor.

In the operation of this carbureter,  $V_1$  is the Venturi tube which first comes into play. The throttle cam  $T_1$  operates the throttle lever  $T_2$ , and opening the throttle position by the lever on the steering wheel moves the throttle cam in the direction indicated by the arrow, thus relieving the air valve  $A_2$  of the pressure holding it down and creating in the tube  $V_1$  a partial vacuum which lifts clappet valve  $C_3$  and permits gasoline and air to enter the Venturi tube. The needle valve  $V_5$  serves to adjust the flow of gasoline to a minimum at the slow speeds of the motor. If the position of the throttle cam  $T_1$  is advanced further, the second air valve  $A_3$  and the corresponding Venturi tube  $V_2$  are brought into action, giving the motor an additional supply of gasoline and air, the proportion of which, however, remains unaltered. Likewise, advancing the throttle cam to its ultimate position brings the high-speed Venturi tube  $V_3$  into play.

The C R G carbureter is manufactured by the C R G Manufacturing Co., Saugus, Mass.

# THE AUTOMOBILE

## Only Two Teams Perfect in Glidden



The Start of the Glidden Tour from New York, the Maxwell Team Waiting at the Line



Governor Hoke Smith, of Georgia, and Governor Woodrow Wilson, of New Jersey, Tourists on the First Day's Run

ROANOKE, VA., Oct. 17—Special Telegram—Mud and hospitality combine to make the Glidden tour up to this city one of intense interest to those who are accompanying it through the vicissitudes of the route. There is a unanimous opinion current among the tourists that the contest is sufficiently eventful to satisfy the cravings for excitement and discomfort of the most exacting. The invitations which pour in amply uphold the reputation of the hospitable South and go far in alleviating the dismal feelings and thoughts inspired by the tropical downpour which has met and all but conquered the Glidden tour.

Four days of the tour are now past, and in the expectations of all the worst is yet to come as far as the condition of the roads is concerned, as the rain is falling heavily over the districts through which the tour is scheduled and there is no apparent relief in sight. Many of the tourists are of the opinion that a delay will be necessary to allow the streams to sink back to their normal level after the terrible rains of to-day. The fords are in many cases so high that the magnetos are flooded whenever an attempt is made to cross them; while in other cases the roads themselves are gushing streams.

Engine troubles have been few, nearly all the delays being directly traceable to the heavy roads through which the cars have bravely struggled and the number of perfect scores is remarkable when the stringent conditions which have arisen are considered. Many teams have imperfect scores owing to the fact that one of the cars in the team fell a victim to the heavy going of to-day while the other two managed to reach the control to-night on time, which is all that is required to escape penalization. There are now but two teams remaining with perfect scores: they are, the Tarrytown team consisting of three Maxwell cars and the Waltham team composed of three Metz machines. To-day's run was responsible for the slaughter of the perfect scores, that part of the road from Natural Bridge to this city doing the





Gliddenites in the checking station at Trenton, N. J., on first day's tour

work. Had it not been for the cloudburst all would have been well.

Up to a late hour to-night the following cars had not checked into the Roanoke night control: No. 6, Thomas; No. 8, Flanders; No. 14, White; No. 18, Garford; No. 29, Cadillac; No. 42, E-M-F; No. 50, Maxwell; No. 55, Flanders, and No. 71, Case. The following penalties have up to this hour been announced on the other cars for to-day's run; No. 33, Cole, 87 points; No. 41, Winton, 21 points; No. 43, Ford, 125 points; No. 4, White, 4 points; No. 47, Cadillac, 23 points; No. 51, Cadillac, 13 points; No. 52, Packard, 14 points; No. 56, Marathon, 72 points; No. 58, Marathon, 9 points; No. 59, Cadillac, 5 points; No. 60, Oldsmobile, 4 points; No. 61, Flanders, 7 points; No. 64, Pierce-Arrow, 3 points; No. 66, Stevens-Duryea, 10 points, and No. 69, Oldsmobile Autocrat, 1 point. The majority of these penalties, it is understood, have been imposed for lateness due to the wretched condition of the roads.

## Perfect Scores Slaughtered

ROANOKE, VA., Oct. 17—Special telegram. To-day was the real Waterloo of the 1911 Glidden tour, at least so far as it has progressed. The tour to-day staggered, tottered for a moment and went on, but it was a spattered remnant of the proud array of automobiles that left New York last Saturday that limped into night control at Roanoke. A cloudburst, such as has not been seen in this section for 20 years, overwhelmed the tour this afternoon and plucked clean scores by the dozens. The scene of the convulsion of nature was in the north end of

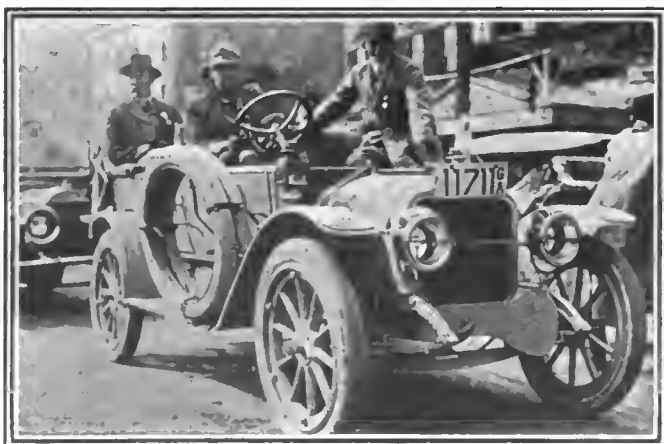

Major Cohen of Atlanta in his White car



R. M. Owen in the Reo Pathfinder on tour

Roanoke Valley, just south of Natural Bridge. For an hour the rain fell solidly and when it ceased to the volume of a mere downpour roads were under water. As a result there will probably be no run to-morrow because creeks are running bank full and fords are impossible if deep enough to flood the magnetos.

Along the way from Natural Bridge contesting cars are lying to-night in the blinding rain abandoned by their crews or are limping towards Roanoke. Nine cars failed to report at night control up to its closing time and fifteen cars were penalized for lateness. President Hooper's Garford non-contestant is in the ditch 17 miles from this city; and accidents were so frequent that they are not being considered individually. Fortunately nobody received serious injuries. There would have been but few clean scores left to-night had it not been for an allowance of 26 minutes made to the running time of each contestant by Referee Walker. The grounds for the allowance rest upon the blockading of the road by two automobile fire engines proceeding toward Roanoke. These engines became mired and held back the procession materially.

The route to-day was from Staunton through the Shenandoah valley to Lexington, with a detour to Lee and Jackson's tombs and the Virginia military institute. Noon control was at Natural Bridge.

The going was poor most of the way into noon control and from Natural Bridge to a point 10 miles from Roanoke they were beyond description under the circumstances. Red clay is the road bed and a pedestrian simply could not stand upon it. The road is narrow and once a car, with a fast schedule, got behind time it was almost worth human life to try to regain position.

Penalizations imposed upon the participants during the first four days of the tour are given in the following table:

Team	No.	Car.	Penalties by days.				Total
			1	2	3	4	
Tarrytown	1	Maxwell	0	0	0	0	0
	2	Maxwell	0	0	0	0	0
	3	Maxwell	0	0	0	0	0
Atlanta 1	8	Flanders	0	0	0	0	0
	63	Flanders	0	0	0	0	0
	61	Flanders	0	0	0	7	7
Atlanta Journal	5	American	0	0	0	0	0
	6	Thomas	0	0	0	0	0
	7	White	0	0	0	0	0
Atlanta 2	11	Stevens-Duryea	0	0	0	0	0
	39	Stevens-Duryea	0	0	0	0	0
	66	Stevens-Duryea	0	0	0	10	10
Atlanta 3	43	Ford	0	0	0	125	125
	44	Ford	0	0	0	0	0
	45	Ford	0	0	0	0	0
Atlanta 4	16	Pierce-Arrow	0	0	0	0	0
	12	Marmou	0	0	0	0	0
	64	Pierce-Arrow	0	0	0	3	3
Atlanta 5	4	Maxwell	0	0	0	0	0
	49	Columbia	0	0	0	0	0
	50	Maxwell	0	0	0	0	0
Atlanta 6	18	Garford	0	0	0	0	0
	19	Mitchell	0	0	0	0	0
	20	Schacht	0	0	0	0	0
Atlanta 7	21	Corbin	0	0	0	0	0
	14	White	0	0	0	0	0
	22	Thomas	0	0	0	0	0
Nashville	56	Marathon	0	0	0	72	72
	57	Marathon	0	0	0	0	0
	58	Marathon	0	0	0	9	9
Waltham	15	Metz	0	0	0	0	0
	16	Metz	0	0	0	0	0
	17	Metz	0	0	0	0	0
Albany, Ga.	34	Halladay	0	63	0	0	63
	35	Halladay	0	0	0	0	0
	36	Halladay	0	31	0	0	31
Detroit, Mich.	53	Flanders	0	591	0	0	591
	54	Flanders	0	0	0	0	0
	55	Flanders	0	0	0	0	0
Cordele, Ga.	60	Oldsmobile	0	0	0	4	4
	65	Oldsmobile	0	0	0	0	0
	69	Oldsmobile	0	0	0	1	1
Florida	28	Cadillac	0	4	0	0	4
	29	Cadillac	0	15	0	0	15
	37	Cadillac	0	0	0	0	0



Atlanta men in Corbin on the Glidden tour

	No.	Car.	Penalties by days.				Total
			1	2	3	4	
Live Oak, Fla.	31	Cadillac	0	0	0	0	0
	51	Cadillac	0	0	0	13	13
	74	Cadillac	0	3	0	0	3
Everglades	33	Cole	0	0	0	87	87
	46	White	0	0	0	4	4
	48	Cadillac	0	0	0	0	0
Jacksonville	32	Cadillac	0	0	0	0	0
	40	Cadillac	0	0	0	0	0
	47	Cadillac	0	0	0	23	23
Unteamed Cars	26	Mitchell	0	0	0	0	0
	27	Chalmers	0	13	0	0	13
	41	Winton	0	0	0	21	21
	42	E. M. F.	0	53	0	0	53
	52	Packard	0	0	0	14	14
	59	Cadillac	0	0	0	0	0
	70	Krit	0	0	0	0	0
	71	Case	0	0	0	0	0
73	Mitchell	0	0	0	0	0	
72	Haynes	0	0	0	0	0	

\*Not reported at night control.

### The First Day's Run

PHILADELPHIA, PA., Oct. 14—The first day's running of the Glidden tour failed to produce any penalizations, all contestants checking into noon and night controls within their schedules.

With sixty-four contesting cars in line, the Glidden tour of 1911 started from New York this morning on its way to Jacksonville, Fla. The day was fair overhead, but the recent dry weather gave promise of much dust.

There were automobiles in the column that have been strangers to Glidden tours for several years, among them being Pierce-Arrow, Packard, Thomas, Winton and others. On the other hand there were many cars of moderate price in the caravan and some of the smallest automobiles made in the United States. It was a typical exhibition of American cars that lined up in West Thirty-ninth street, facing Fifth avenue in New York at the start.



One of the Flanders cars in the Glidden



The team of three Marathon cars from Nashville, Tenn., waiting for start of the tour

## Glidden Tour Road Scenes



These are typical views of the roads through Pennsylvania and New Jersey on the first day's run of the Glidden Tour. The New Jersey roads are proverbial for their excellent condition. The two lower illustrations are Pennsylvania scenes, the middle one being near Gettysburg and the bottom one in the vicinity of Lanhorn. The State of Pennsylvania has built miles of good stone road within the last 5 years, but the great problem has been that of keeping the surface in a good state of repair. It is one thing to build a good road and it is another problem to keep the road in a proper condition. To-day the maintenance problem is the big one in the road building field.

Behind the wheels of the cars were millionaires, business and professional men, representing the most progressive element of the New South, factory drivers of tried ability and a few chauffeurs. Riding as passengers were at least a dozen men whose names have a significance that is nation-wide.

Governor Hoke Smith of Georgia entertained Governor Woodrow Wilson of New Jersey as far as noon-control at Trenton and it is said that the Governor of Georgia remarked to the Governor of New Jersey on one occasion when it seemed as if there might be some lateness at noon-control: "Let's beat it."

There were big welcoming delegations at Newark, New Brunswick and Trenton. The column reached Philadelphia in perfect order and with no perceptible straggling.

Besides the contesting cars there were thirteen officials, non-contesting and press cars attached to the caravan. All told there were about 275 persons riding in the cars.

At Philadelphia the associated automobile clubs tendered the tourists a smoker and entertainment at the Hotel Walton which was liberally attended. The day's route was 101.1 miles, all of which was over excellent roads.

This is primarily a good roads tour. There are no technical penalties to be imposed, reliability in reaching controls on time being the single requisite for a clean score. The total mileage to Jacksonville is 1460.6 and the daily routes are not particularly strenuous.

The main trophy presented by Charles J. Glidden and which bears his name will be awarded to the three-car team that finishes the run with the least number of demerits. The Anderson S. C. trophy will go to the car having the best score and in addition cash prizes of \$199 will be given to the runabouts and touring cars in each of the seven divisions of Class A under the rules of the A. A. A. In case of ties for either trophy the winners will be selected by drawing for numbers or flipping a penny.

## Philadelphia to Gettysburg

GETTYSBURG, PA., Oct. 15—To-day's penalties are: Chalmers No. 27, 13 points; Cadillacs Nos. 28 and 29, 4 and 15 points respectively; Halladays Nos. 34 and 36, 63 and 31 points respectively. Besides these Flanders 53 broke an axle and was not in at midnight.

Three teams lost their chances for a clean score as a result of to-day's run in the Glidden tour. One unattached car, Chalmers 27, was also penalized for lateness into night control. The sufferers were: Cadillac 28, which loafed along this morning and then had tire trouble while trying to make up time; Cadillac 29, which went astray from the confettied course and experienced tire trouble while racing to control; Halladay 34, which skidded into a curb while in control at Lancaster and bent its right front spindle and axle and smashed its running board; Halladay 36, which took its points for standing by its disabled teammate, and Flanders 53, which suffered a broken axle near Gettysburg and is still out at midnight.

Sunday dawned with leaden skies and at checking out time the rain commenced to fall dismally. All day it continued intermittently and despite the good roads traversed before reaching Lancaster, Pa., several of the cars were in trouble at noon control. The route was only 120.1 miles and was all good except about 8 miles into night control. These 8 miles, however, are notoriously the worst in Pennsylvania and they racked and strained the cars so that many of them will show the effects between this time and final control at Jacksonville.

A visit to the battlefield at Gettysburg was the feature of entertainment offered the tourists this afternoon and many of them took advantage of it. A canvass of the party disclosed the fact that almost without exception the tourists were represented in the great battle of 1863 by near relatives. As the party is composed largely of Southerners, the side that fought under the Stars and Bars received the more general scrutiny as to position on the battlefield. Governor Smith of Georgia enter-

tained Governor Tener of Pennsylvania over part of the course to-day.

Out of the contesting column, which consists of eighteen teams and ten unattached cars, all have clean scores except the Albany, Ga., team, Florida State team, Detroit team and the Chalmers car as stated. The Maxwell, Marathon and Metz teams are being very carefully driven and have not suffered so far. The big cars have performed splendidly so far, Thomas, Packard and Pierce-Arrows going along without a skip and the Stevens team doing brilliant work. One noteworthy feature of the run has been the freedom from engine trouble, practically none of it having been encountered by the participants of the Glidden Tour up to this time.

## Entering Dixie Land

STAUNTON, VA., Oct. 16—The only penalty to-day was E-M-F No. 42, which has not reported yet. To the inspiring strains of "Dixie," the Tour rolled into Staunton this afternoon after the longest run of the tour and what will certainly be one of the pleasantest. The dust and rain and fog disappeared at the entrance to the smiling Southland and the Virginia roads fulfilled all the pleasant promises that had been made for them.

Three of the greatest battlefields of the Civil War were traversed to-day when the cars passed over a part of the Gettysburg field, where the pivotal contest of the war was fought; Antietam, where the blue and gray battled to a desperate draw and the great Shenandoah Valley, where Early, Stewart, Sheridan and Warren battled to and fro and devastated it for three fierce years.

To-day there is no sign of that struggle in the peace and prosperity that enwraps the valley save that here and there the beloved Stars and Bars are displayed in honor of the tourists alongside the Stars and Stripes.

Winchester, seated at the gateway, is one of the best automobile towns of its size in the country. There are over 300 small cars of one make owned in Winchester and through a radius of ten miles. The city has five lively and prosperous agencies which handle a typical line of automobiles. Winchester is immortalized in heroic verse of Buchanan, describing Sheridan's wild ride to rally his disordered troops and gain a fundamental victory from what looked like disaster.

One of the features of the reception at Staunton was the parade of the cadet corps of the Virginia Military Institute. This battalion stood at Present Arms during the passage of the contest in cars.

There was only one penalization as the result of to-day's run. E-M-F 42 ran into a chuckhole near Charleston, W. Va., and wrecked two wheels. The car had not reported at 9 o'clock to-night and will receive a large number of demerits. It is being repaired as rapidly as possible.

There was one accident during the run. The Pierce-Arrow press car carrying the starter and his assistant and driven by O. A. Britson of Brookings, S. D., rammed a telegraph pole while going at a high rate of speed and turned turtle. Nobody was hurt but the car was badly damaged. The fault lay in the fact that too much speed was being used.

There were two additional penalizations for yesterday's run that were not included in yesterday's scores. These were Cadillac 74, which was given 3 points for being late after losing its way, and E-M-F 42, which was demerited 53 points after suffering a road accident in the heavy going east of Gettysburg. Flanders 53, which broke an axle on the second day, reached control at Gettysburg at 3 o'clock this morning, joined the column and made a perfect score to-day. Its penalty for lateness was 591 points.

There were no penalties posted to-night as the result of to-day's run.

Governor Smith entertained Governor Glasscock of West Virginia for part of the day's run and is booked to ride with the governors of all the States traversed by the tour.

## Glidden Tour Road Scenes

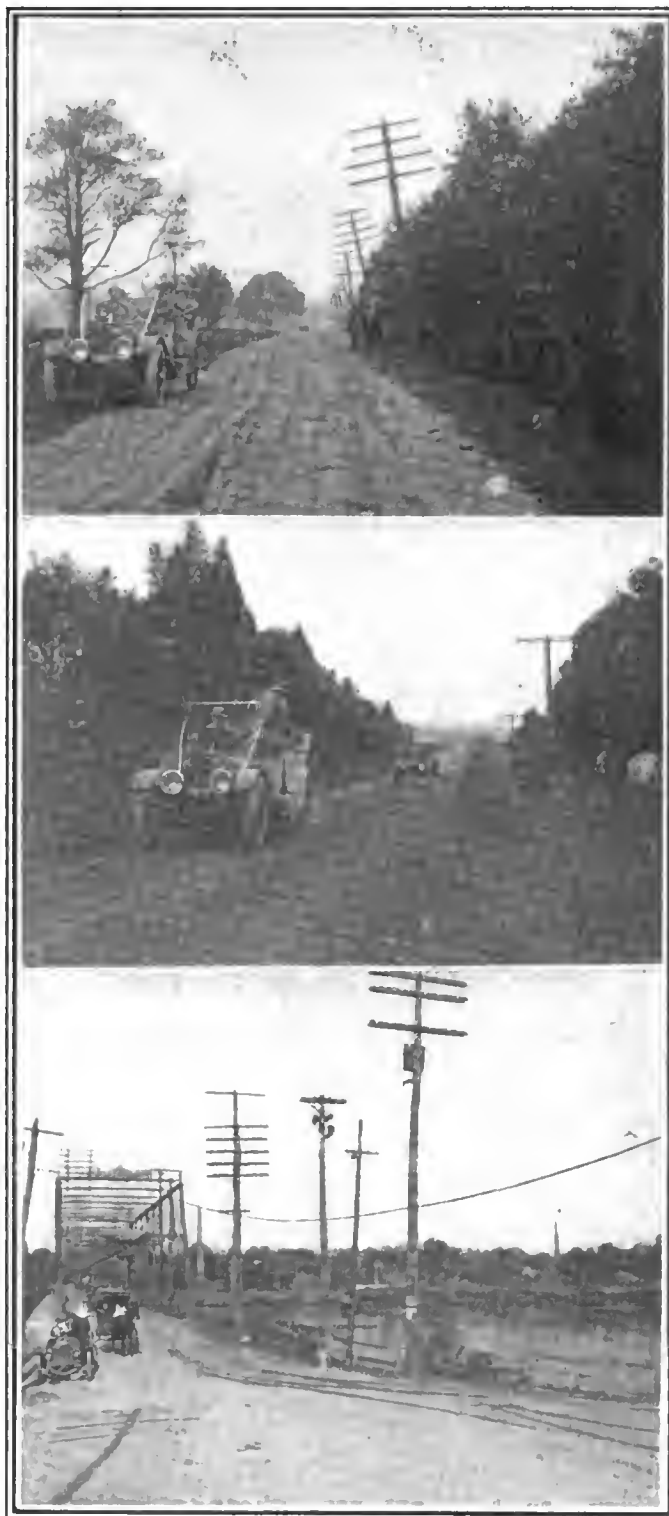

*These illustrations show typical road scenes on the route of the Glidden tour through the State of Pennsylvania. Both of the upper illustrations are photographic reproductions of roads in the vicinity of the famous Gettysburg battlefield, which point was reached on Sunday evening after travelling all day in a steady rain. The bottom illustration shows the bridge over the Delaware River on the boundary line between New Jersey and Pennsylvania; this point was passed on the first day of the tour. The roads on the first portions of the tour will be much better than those near the end of the tour in Southern Georgia and Florida.*



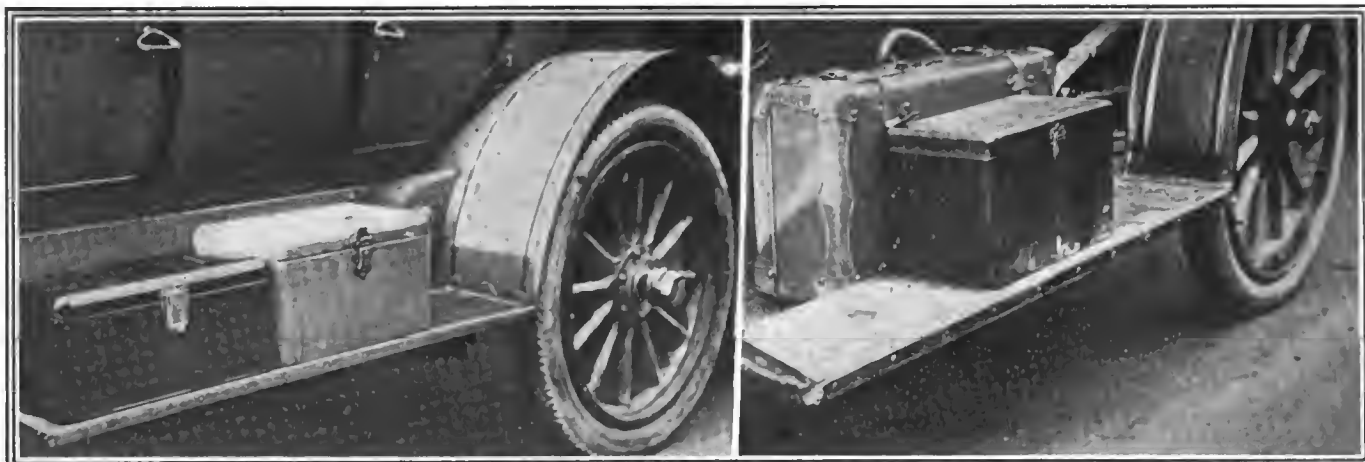

Fig. 1—Showing how a second neat box can be carried on the running board Fig. 2—A suit case can be placed between the running board and body

## Subduing the Baggage Problem

THE cars which were lined up for the start of the Glidden tour could not but inspire a large amount of food for reflection in the mind of one who strolled along the length of the line and inspected the various methods adopted by the entrants to the tour in storing their baggage and spare parts. The inspection did not have to be more than casual to disclose the fact that while neatness was the predominant feature with a majority of the contestants, there were many whose baggage arrangements could have been markedly improved.

With very few exceptions, the running boards of the cars were called upon to play a significant part in the transportation of the dead weight. The arrangements were many and indicated wide variations in the ideas of security held by the owners of the different cars. In many cases an extra box was fitted alongside the toolbox and the appearance was very workmanlike and neat. In this box small articles which would generally be either in the way in the car itself or else at the bottom of a pack containing a mass of material of large size, could be packed. In the former case it would as a rule be thrown away in disgust if it could possibly be dispensed with, while in the latter case it would probably be dispensed with after a vain search and a like amount of disgust. With the small box fitted upon the running board as shown in Fig. 1, the little pieces of material such as a ball of twine, a small coil of wire or any of the hundred and one things which suggest themselves as needed upon a tour of any length, may be comfortably stowed away

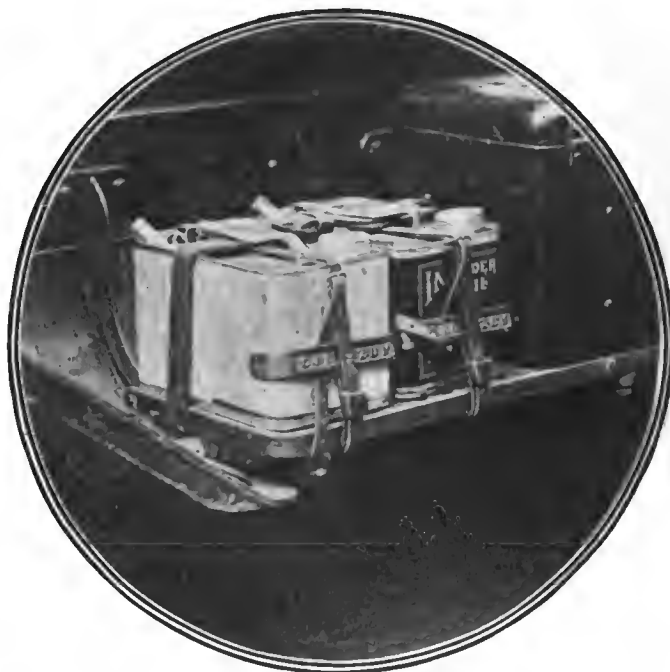

Fig. 3—Neat brackets with straps for carrying oil cans on running boards



Fig. 4—This is not the neatest way of securing suitcases on a car during a tour. A strap would have been much better

where they will be at hand whenever they are required.

In place of the small box a suit case will often be fitted as shown in Fig. 2. If this be suitably fastened so that it will not acquire the disagreeable habit of jumping off the running board every time the car meets an inequality in the road, it will no doubt serve the purpose as well as the small box mentioned above.

The running board can be utilized in other ways as is shown in Figs. 3 and 4. In the latter of these two illustrations the rear of the car is depicted laden with suit cases which seem to be fully capable as far as size and quantity are concerned to carry the needs of the two passengers for which the car is adopted upon a tour of remarkable length. A watertight cover can be seen stowed just to the rear of the suit cases. This is for use no doubt in case a rain storm should spring up. Since a storm is not governed by any laws of appearing gradually it is assumed that the cover may be taken out in a hurry; from the manner of roping down the suit cases and cover with one rope it would seem to indicate that after the storm cover were detached it would be necessary to rebind the cases. This is not convenient. A neat method of carrying oil cans is disclosed by



a glance at Fig. 3. Bronze brackets are fitted which support the cans and pass beneath the running board; straps are then attached to the brackets and the whole outfit is firmly held and yet can be taken down for use in a remarkably short space of time. The tool box is fitted next to the oil cans so that the whole available space on the running board is made use of and yet it does not give a littered appearance.

The arrangements in the tonneau of the cars on a tour where passengers are carried are of great importance. This will no doubt be food for reminiscence for those who have ever had the questionable pleasure of traveling in a car for any length of time, when the tonneau was so crowded with excess baggage that the only apparent place to put their feet was somewhere in the neighborhood of the top of the front seat. It is a fact that the more one travels the less one carries. Every trip of any length will disclose the fact that some formerly treasured

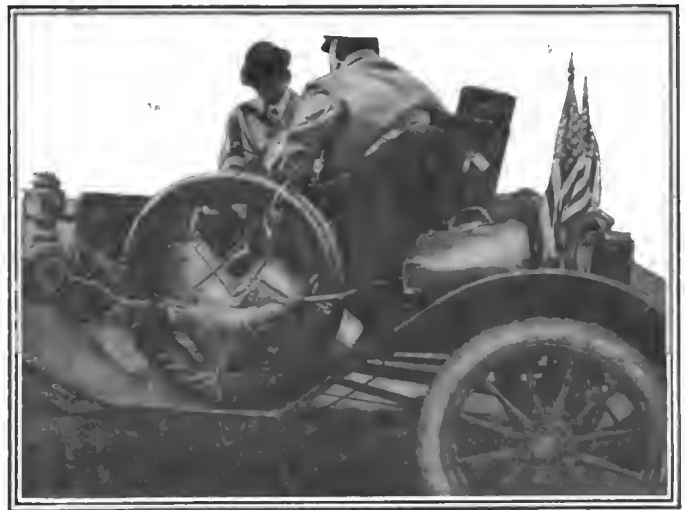

Fig. 5—The good appearance of any car is spoiled by cluttering it all up with baggage, at each side and in rear

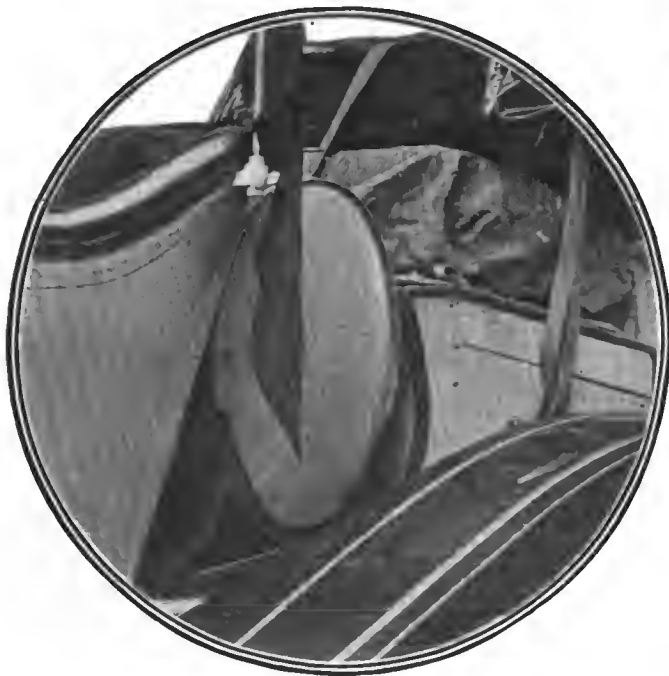

Fig. 6—Suit cases can be wrapped in waterproof cloth and carried back of the gasoline tank

piece of baggage could be dispensed with and its loss never felt. Yet it is none the less a fact that what many persons regard in the light of effete luxuries are to others indispensable necessities, yet even when carrying these few pieces of perhaps unnecessary luxuries, it is generally the case that they can be stored with a little care so that they will never be the cause of the slightest annoyance to the driver or his passengers. On the other hand a glance at Fig. 8 will show a case where the storage of loose articles about the floor of the tonneau will probably lead to great discomfort to the passengers on the first bit of rough road encountered, and yet it is probably a fact that every piece of loose material is of necessity. One can however well imagine the lively tattoo that the jack will beat upon the sides of the oilcans as soon as the roads deviate from the smoothness of the populated districts.

In a tour of the nature of the Glidden, space and trouble may be saved to a number of drivers and other occupants of the cars by having a non-contestant car accompany them for the sole purpose of carrying their extra baggage. The tonneau of this car can be heaped to the gunwales with suit cases and boxes and yet the chances of losing any of them are comparatively slight. There are no passengers to be carried in the car in this

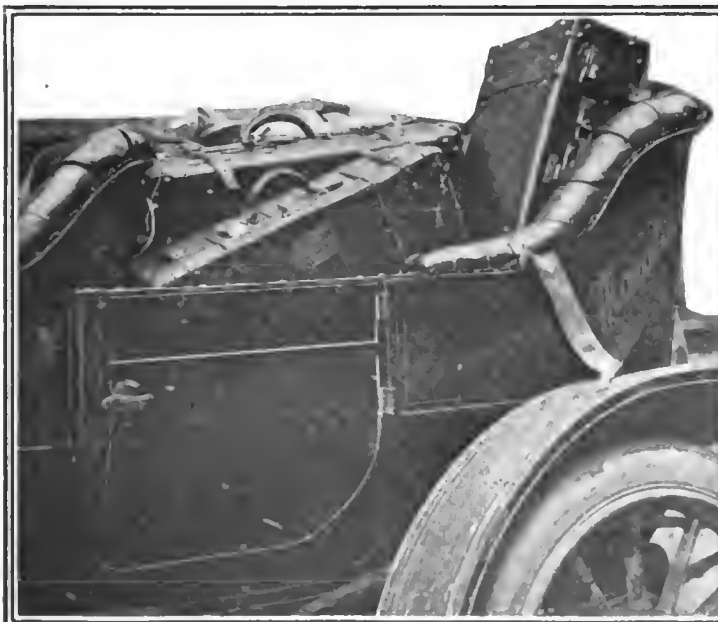

Fig. 7—This car was used solely to carry baggage for the tourists on the Glidden. There were some that carried baggage and passengers in the tonneau



Fig. 8—This is the tonneau of one car that started on the Glidden tour. Baggage, gasoline, oil and tools were all mixed together



Fig. 9—A carful of ladies ready to start on the Glidden Tour. Note the poor position of the valise on the side compared to the valise on the rear

case and therefore there will be plenty of room as may be seen in Fig. 7, where the non-contestant car in the Glidden Tour is illustrated.

There is nothing, perhaps, which will tax the ingenuity of the tourist so much as the arrangement of the spare tire cases, and



Fig. 10—Suit cases lend themselves to storage because they are flat



Fig. 11—Plenty of room for the passengers in this tonneau

in this matter it is as a rule better that some standard contrivance which has been made for the purpose, be used. It is needless to say that the tire should be well covered, for anyone knows that it is anything but a delectable occupation to scoop the accumulated mud and dirt from the interior of the shoe before fitting it to the rim. In most cases the tires are covered and there are few uncovered cases among a line of cars starting upon a lengthy tour; it was the case, however, in the Glidden that many pinned their faith to brown wrapping paper of rather uncertain thickness which may or may not be a wise proceeding, according as to how thoroughly the casing was bound up in the paper and how well the fastenings were made. A convenient method of carrying spare tires is illustrated in Fig. 5, where the tires are shown upon the running board helping to support two parcels. The coil of rope which should always accompany a car when on a tour of any length is bound to the spare shoes in such a manner that it may be readily detached in case of need.

The rear of the car forms the most natural point to suspend the baggage. A neat arrangement of cases will permit of a considerable amount of weight being carried in a manner that it will not take up an excess of space. A reference to Fig. 5 may be made for the purpose of pointing out the small valise stowed upon one side. A valise makes a very fine bag to carry in the hand, but its shape does not aid it in its amenability to storage. The suitcase, on the other hand, on account of its shape may be fitted nearly anywhere. It is evident to the observer that the valise in the illustration would be in grave danger of falling out upon the slightest provocation. An arrangement of suitcases in the rear of the car is shown in Fig. 12. There are three here piled one upon the other and when strapped as shown, are as safe as could be desired from any road shocks or other ordinary vicissitudes of automobile travel. Another case of three suitcases being piled upon each other may be seen in Fig. 10 where the running board is utilized for the purpose. There is plenty of baggage room here for three people and yet room for the spare tires is also found upon the same running board.

Next to the suitcase or the trunk, in order of amenability to storage comes the flat package. Examples of the manner of storing these packages may be seen in Figs. 6 and 15; these take the place of a trunk and are capable of carrying more than a single suitcase. They have the disadvantage, however, that the whole outfit has to be unpacked for the purpose of removing any one article no matter how small it may be. These tarpaulin packages have the same feature as the suitcases, however, inasmuch as they are capable of being stored nearly anywhere the driver may wish to put them. Only the larger cars

are fitted with trunks as a rule, but a trunk rack is a handy adjunct to any car and where the owner has merely to let down the rack and place the trunk upon it he will be saved a large amount of trouble. An example of a trunk fitted to a touring car is shown in Fig. 12.

It is an impossibility for a car to make a successful tour without possessing the quality of being shipshape. Where all the luggage is permitted to float around the floor of the car loosely it is bound to cause trouble sooner or later. Everything should have a place and should be kept in it regardless of the fact that it may be of such a nature that it will be occasionally required by the occupants of the car. If it is of this nature, an arrangement such as a bracket may be made which will permit of easy removal and replacement.

Loose small articles should be studiously avoided. A heavy jack should never be placed loosely upon the floor where oilcans are resting, perhaps without being tied, as is seen in Fig. 8. Dirt should be avoided just as carefully, as it can cause damage at times. A case in point is the radiator which may be choked with the mud thrown from the wheels. To prevent this occurrence aprons should always be fitted where the going is rough and muddy. The aprons are shown in Fig. 13 and illustrate the attention which when accompanied by foresight, will greatly eliminate worry on the tour. If all these points are noted the passengers in the tonneau will not, when on a rough road, have to futilely chase the tire pump while the jack is gaily ramming a hole through the expensive thermos bottle.

There are certain rules concerning the storage of baggage which should be followed whether the car is a contestant in a tour or is merely starting for a day's run over some nearby roads. They may be summed up in brief: The smallest piece of baggage should be as accessible as the largest, *i.e.*, if it is desired to jack the car up and remove a tire it should not be necessary to request the ladies who are occupying the seat in the tonneau to step out into the soft mud which generally surrounds the car when tire troubles put in their appearance. Another point which might well be made is to have the baggage so arranged that it will not be necessary to hunt vainly about the several packages before the one containing the article sought for is located. Last, but not least, the baggage should never, under any circumstances short of complete demolition of the car, be allowed to shift with the inequalities of the road. No one would think much of the captain of a ship who allowed himself voluntarily to be caught with a shifting cargo in his vessel's hold.



Fig. 12—There is nothing better than a neat trunk rack for carrying baggage



Fig. 13—Mud guards of this nature keep the radiator clean on long tours

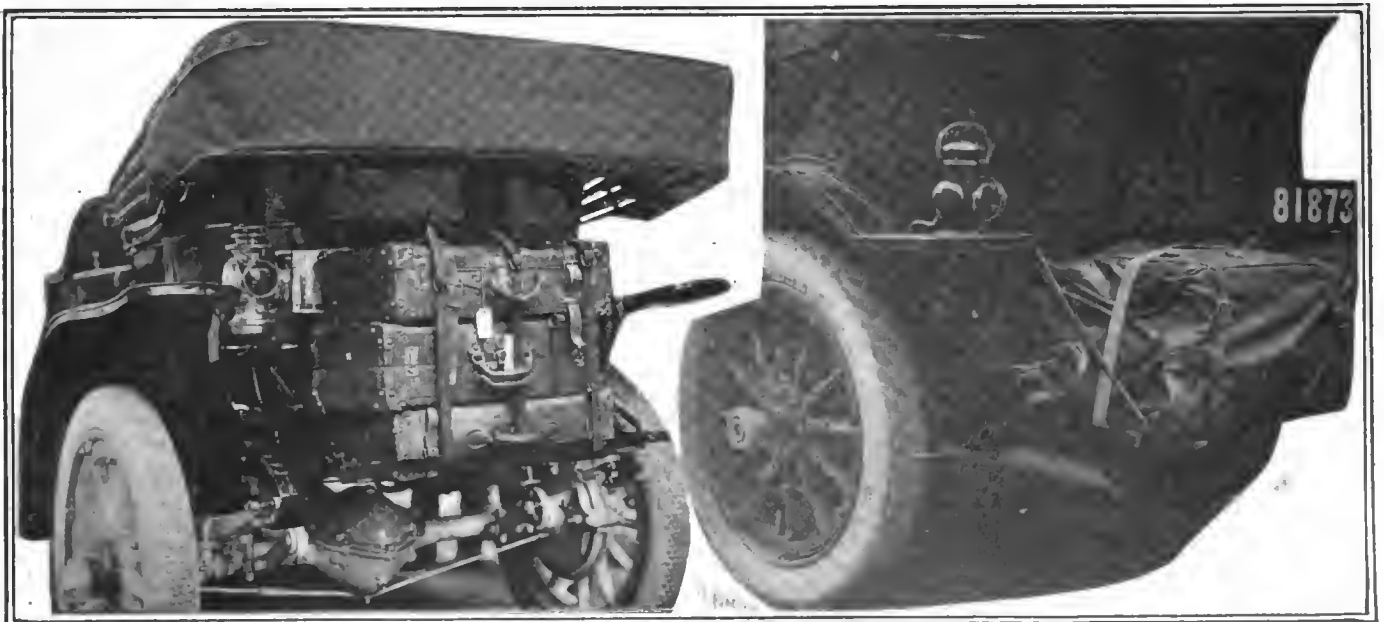

Fig. 14—Three trunks can be carried quite easily on a trunk rack on the rear of a car. They should be wrapped in a waterproof covering

Fig. 15—If suit cases have to be carried on the back of a car, it is best to wrap them up to protect them from the rain and dust during tour

# National Breaks World's Road Mark

## Herrick and Merz Shatter Florio Mark

**L**OS ANGELES, CAL., Oct. 14—Special Telegram—America has captured the road race record of the world. Herrick, driving a National, broke it to-day on the now famous Santa Monica course near this city. Nazzaro, in the Fiat, has held the road race record since the season of 1908, but now it rests in America, an American car, driven by an American driver, doing the work.

Harvey Herrick is the hero; he is a Los Angeles boy and drove a National 40 for the 202 miles of the race in 2 hours, 42 minutes and 24.6 seconds, which is an average speed of 74.62 miles per hour. The previous road record held by Nazzaro was a speed of 74.3 miles per hour made on the Florio cup course in the season of 1908. The new figure of Herrick was made on a shorter circuit than that on which Nazzaro gained his laurels. Many attempts have been made to wrest the road record of the world from Europe, special roads have been built in different parts of America for this work, turns have been banked and other precautions taken, but the honor has finally been taken by the West, and Harvey Herrick, the hero, has been driving in West Coast events for the past six months. This record was made in the free-for-all race, the tabulation of which is given on this and the following page.

But Herrick did not have it all his own way in the record-smashing program on the course to-day. Charles Merz, a National factory driver, also piloting a National 40, won the heavy car race over the same circuit, averaging 74.42 miles per hour. He also shattered the Nazzaro figures, but was a little behind the pace of Herrick. This heavy car race was for 152 miles.

There were two other races over the same circuit to-day and also two winners. Keen, driving a Marmon in the 231-300 cubic inch piston displacement class, won, driving the 151 miles in 132 minutes and 9 seconds, which is an average speed of 68.7 miles per hour.

The last and smallest race of the day was for cars with a piston displacement of under 231 cubic inches and for a distance

of 101 miles. Nikrent, driving a Buick, captured this event, doing the distance in 103 minutes and 21.70 seconds, which is an average of 59.20 miles per hour.

Herrick was the dark horse in the big race. He had to his credit the Bakersfield road race of last July and the Los Angeles to Phoenix desert race of last year. But he was not even a member of the National team which came out from the factory. In deference to the local agent, Herrick had been permitted to handle the car which was already here. When the coastman finished last with the same car in the 301-450 class event he became even more of a dark horse. His trouble in the heavy car event had been due to tires. He was making too much speed around corners. In the time between the class race and the free-for-all Herrick quietly mapped out his race and once under way he furnished the most consistent performance ever seen in an American road race.

The free-for-all for the Dick Ferris cup was a bitter fight between the Nationals and the Marmons. Bert Dingley in a Pope-Hartford was a contender up to the twenty-second lap when repeated tire changes put him out of the running. The fastest laps were reeled off by Tetzlaff, the winner of last year's race, in a Fiat. With 75 miles of the race completed the Fiat led by 4 minutes but from there on it began having engine trouble. Several times Tetzlaff stopped and made minor adjustments on his engine and once changed spark plugs at his pit. During the last half of the race he was not a contender.

At the start Tetzlaff and Wilcox in the National 50 set a hot pace. With three laps completed the Fiat led Wilcox by 56 seconds with Dingley third. The leaders had tire trouble in the fourth, but Tetzlaff retained his lead, while Patschke in a Marmon moved up to second and Dingley kept third. The Midland twisted its magneto shaft and stopped at its pit the first time around. Wilcox threw a tire on the Palisades turn, making a very spectacular skid, but bringing his car to a stop without trouble.

### ANNUAL SANTA MONICA ROAD RACE IN CALIF

#### Free-for-all Race—202

CAR	DRIVER	Lap 1	2	3	4	5	6	7	8	9	10
NATIONAL.....	Herrick.....	7:02.07	13:42.04	20:26.39	27:09.05	33:52.55	40:34.55	47:17.15	53:55.5	60:34.1	.....
MARMON.....	Patschke.....	6:33.8	6:40 15:41.4	6:44 22:47.2	6:45 25:49.14	6:43 32:15.25	6:42 40:21.8	6:43 47:18.85	6:38 53:48.9	6:39 60:27.86	6:38 67:05.23
MARMON.....	Dawson.....	6:54.69	9:08 13:43.61	7:06 20:29.12	3:02 27:05.47	6:26 33:44.39	8:06 40:35.25	6:57 47:21	6:30 53:39.8	6:39 60:41.2	6:38 67:23.07
			6:49	6:46	6:36	6:39	6:51	6:46	6:18	7:02	6:42

#### Heavy Car Race—Distance 151.5 miles—

NATIONAL.....	Merz.....	7:03.52	13:46.55	20:29.60	27:10.45	33:51.45	40:37.45	47:18.55	53:59.35	61:52	68:42.4
POPE-HARTFORD.....	Dingley.....	6:49.62	6:43 13:24.31	6:43 19:59.80	6:51 26:37.95	6:41 33:11.9	6:46 39:51.25	6:41 46:38.8	6:41 55:19.45	7:53 61:54.7	6:50 68:36.85
STUTZ.....	Lewis.....	7:17.92	6:35 16:14.7	6:35 21:05.25	6:38 27:57.10	6:34 34:48.3	6:40 41:41.85	6:47 48:34.85	8:41 55:25.3	6:35 62:12.7	6:42 69:02.1
			8:57	4:51	6:52	6:51	6:53	6:53	6:51	6:47	6:50

#### Medium Car Race—Distance 151.5 miles

MARMON.....	Keen.....	7:43.65	14:56.90	22:06.10	29:18.40	36:31.10	43:56	51:08.6	58:51.95	65:48.9	73:19.85
MARMON.....	J. Nikrent.....	7:45.60	7:13 15:03.35	7:10 22:20.05	7:12 29:35.30	7:13 36:54.80	7:25 44:13.25	7:12 51:31.8	7:43 59:40.25	6:57 67:02.2	7:21 74:18.60
MERCER.....	Hanshue.....	7:45	7:18 15:10.55	7:13 22:12.20	7:15 30:11.40	7:19 37:40.85	7:19 45:10.20	7:18 52:38.05	8:09 60:05.50	7:22 67:27.10	7:16 74:52.6
			7:25	7:02	7:59	7:29	7:30	7:28	7:27	7:22	7:25

The only accident of the race occurred on the Interstate's fourth lap. Harry Endicott was approaching the turn when Tetzlaff overtook him and as they went into death curve together the exhaust from the Fiat blinded Endicott and he failed to make the turn, his car hitting the heavy iron rails which had been placed to prevent the cars crashing through a high board fence. The car was partially wrecked but with the exception of a few bruises and a sprained arm Endicott was not injured.

The first 50 miles was covered by Tetzlaff in 37:52. The Fiat had been reeling off laps at an 80-mile-an-hour average. The remainder of the cars were bunched, Patschke being 11 seconds ahead of Dingley, and Herrick 2 seconds behind the Pope-Hartford, and 1 second ahead of Merz. At the end of the ninth lap it was Tetzlaff. He led Patschke by 3 minutes 59 seconds. Herrick was 7 seconds behind and running strong. Tetzlaff came to grief on the tenth lap. He tried to take the Nevada turn too fast and blew two tires. This lost him the lead, Patschke taking first, followed by Herrick only 11 seconds behind. Even this far the ultimate winner was being given little consideration. This condition continued through the next lap, Dawson moving up to third. Wilcox had been gradually losing out on account of tire trouble. He changed two tires in the eighth lap and also stopped in the thirteenth, fifteenth and twenty-first.

It was Patschke, Herrick and Dawson in the thirteenth and in the fourteenth Herrick gained 3 seconds on the leader. A tire change threw Herrick back into fourth place in the fifteenth, Dawson going to second and Dingley to third. Tetzlaff was 14 minutes behind, completely out of it. Dingley crept up to second in the sixteenth and was still holding that position the next time around. Two bad laps sent Dawson back to fourth, Herrick coming to third.

With four laps yet to go, Patschke was leading Dingley by 1:05. Herrick had been making up his lost seconds and was only 7 seconds behind Dingley. At this stage it was anybody's race. One more lap and Herrick had taken second place from the Pope-Hartford, but the Marmon still led. The Marmon went by the stand missing and from there on Herrick went after the race, making his fastest laps toward the end. The twenty-third lap put Dingley out of it and from there on it was easily Herrick. With only 16 miles to go the result was still in doubt and the winning by the Los Angeles boy was the cause of the wild enthusiasm.

Patschke and Dawson rolled into second and third places when Dingley fell by the wayside. Merz in the second National 40 had been coming fast and finished fourth.

The heavy-car race, for the Leon Shettler cup, was a battle royal between the Pope-Hartford, Stutz and two Nationals. Dingley was away in front and he continued to hold the advantage until the eighth lap. Tire trouble stopped Herrick in the fourth and fifth laps and Dingley made a change in the eighth. The tenth lap once more saw Dingley leading with Merz 6 seconds behind and Lewis in the Stutz and Herrick less than a minute in the rear. The eleventh brought more grief to Herrick in the shape of bad tires, while Merz continued to trail Dingley by 5 seconds. Merz gained a second on the next round and on the fourteenth, when Dingley was twice forced to stop for tires, the National went to the front and was never headed. At the finish only 2:56 separated the first and fourth cars.

The medium-car class was a hot fight between the Marmons, Mercer and Buick. At the finish of the fifth lap Keen in a Marmon led Nikrent, also in a Marmon, by 23 seconds. With ten completed Keen led by 59 seconds with Hanshue in the Mercer 34 seconds behind. Nikrent with only 3 laps to go was 48 seconds behind the leader. Keen won by 53 1-2 seconds over Nikrent and 1 1-2 minutes ahead of Hanshue. Nine started. This race was run at the same time as the heavy-car event.

Nine started in the light-car race, for the Chanslor and Lyon trophy, at 101 miles, which was sandwiched in before the free-for-all. The Maxwell lost its flywheel in the third lap and the Regal had engine trouble. Hanshue, in the Reo, set a fast pace but by consistent running Nikrent took the Buick to the front in the latter part of the race. The E-M-F looked all over the winner as late as the ninth lap, but a broken water connection caused a stop for repairs and more water and this lost the race for the Detroit car. The Ford was second to the Buick.

The day was ideal for racing, the warmth of the California sun combining with the breezes of the Pacific to make a balmy Spring day in October. Racing started at 8:30 and there was only a short intermission between events.

The crowd was immense, being estimated all the way from 75,000 to 100,000. It formed a solid mass of people around the entire 8.4-mile circuit, and every available seat was occupied. With the exception of the slight accident to Endicott, not a person was injured. The course was well guarded and the people gave the cars all the track. Several of the drivers provided thrills at the turns, a number going straight ahead at Nevada. This turn was banked last year. This year it was left flat and despite the fact that it was a right-angle curve all cars but one took it without accident.

(Continued on page 686)

**ORNIA—TIME BY LAPS—OCTOBER 14, 1911**

miles—No limitations

	11	12	13	14	15	16	17	18	19	20	21	22	23	24	Miles per Hour
73:58.78	80:39.17	87:19.75	93:59.05	102:28.6	109:16.5	115:54.35	122:30.25	129:04.89	135:42.17	142:15.71	148:58.45	155:44.37	162:27.6		74.62
13:24	6:41	6:40	6:40	8:29	6:48	6:38	6:36	6:34	6:38	6:33	6:43	6:46	6:43		6:43
73:46.2	80:26.45	87:04.85	93:47	100:27.67	107:14.1	113:58.39	120:46.96	127:35.69	134:30.57	141:26.65	150:58.2	158:20.14	165:42.73		73.24
6:41	6:40	6:38	6:43	6:40	6:47	6:44	6:48	6:49	6:55	6:56	9:32	7:22	7:22		7:22
74:00.4	80:42	87:27.05	94:10.2	100:50.57	110:09.8	120:04.1	126:39.6	133:20.75	140:05.51	148:09.07	154:46.06	161:21.72	167:54.53		72.16
6:37	6:42	6:55	6:43	6:40	9:19	9:55	6:35	6:41	6:45	7:04	5:37	6:35	6:33		6:33

**301-450 cubic inches—Non-Stock**

75:24.10	82:02.40	88:46.34	95:24.23	102:02.75	108:33.75	115:28.65	122:08.45								74.42
6:42	6:38	6:44	6:38	6:38	6:31	6:53	6:29								
75:20.25	82:01.05	88:42.85	96:27	103:52.15	110:26.25	116:57.1	123:26.3								73.64
6:44	6:41	6:41	7:45	7:25	6:34	6:31	6:29								
75:48.75	82:57.75	89:48.7	96:43.85	103:43.15	111:00.25	118:00.10	124:56.95								72.18
6:46	7:09	6:51	6:55	7:00	7:17	7:00	6:56								

**—231-300 cubic inches—Non-Stock**

80:35.65	87:50.50	95:16.10	102:41.40	110:08.70	117:24.45	124:45.53	132:09.95								68.7
7:16	7:15	7:26	7:25	7:27	7:16	7:21	7:24								
81:47.35	89:03.75	96:21.25	103:38.85	110:56.55	118:22.2	125:44.85	133:03.5								68.32
7:29	7:16	7:18	7:17	7:18	7:26	7:22	7:19								
82:15.60	89:39.05	97:03.85	103:23.55	111:44.	119:03.25	126:24.20	133:41.20								67.99
7:23	7:14	7:24	6:20	8:21	7:19	7:21	7:17								



# California Tests Commercial Cars

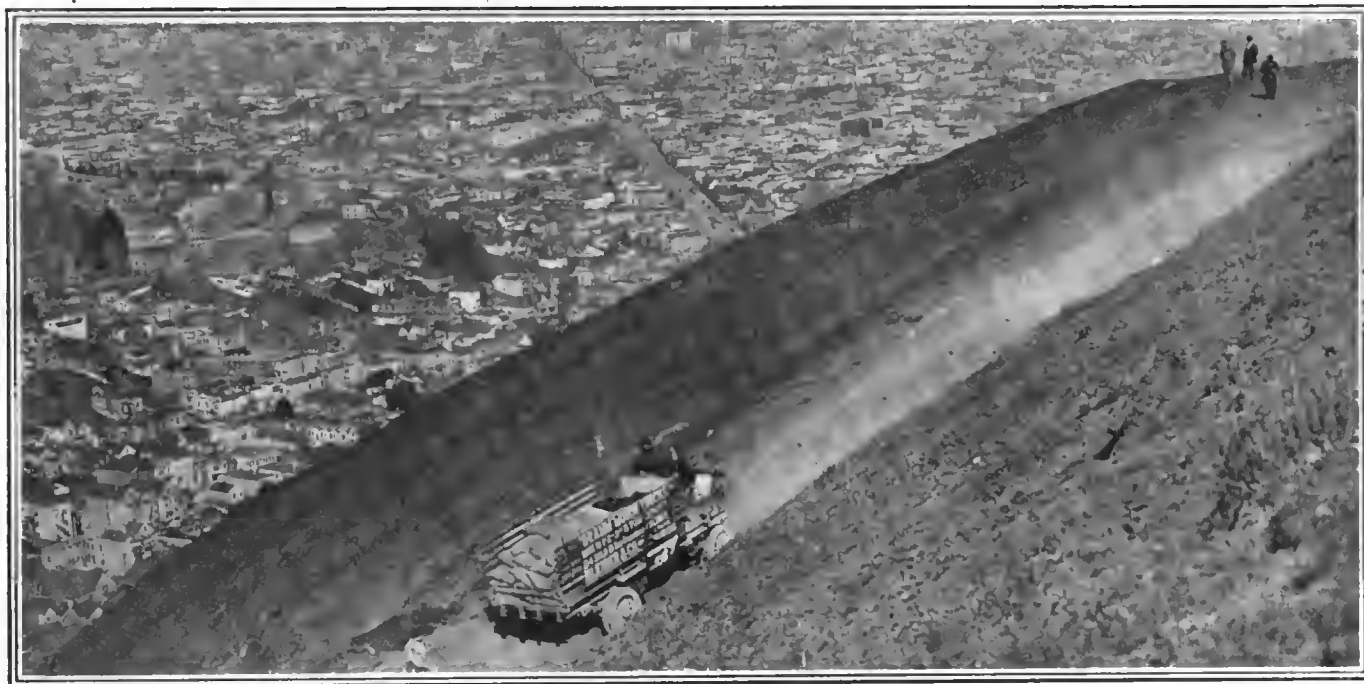

Gramm 6-ton truck, which finished with a perfect score, climbing Twin Peaks Hill



The Speedwell truck, which went through the run without a penalty

**S**AN FRANCISCO, CAL., Oct. 7.—California set the ball rolling in the commercial vehicle test held on October 4 and 5, when twenty-two trucks and delivery wagons contested over roads and city streets. When the 2-day test was over eleven still had their perfect scores remaining, a most creditable performance for a test of the kind. The winners in the six divisions were:

Division 1K, up to 500 pounds—Brush delivery car.

Division 3K, 1001 to 1500 pounds—Reo light delivery car.

Division 4K, 1501 to 2000 pounds—Grabowsky truck.

Division 5K, 2001 to 3000 pounds—White No. 4.

Division 8K, 5001 to 7000 pounds—Kelly truck.

Division 9K, 7001 to 10,000 pounds—White No. 19 and White No. 23 tied.

These awards were made on the basis of road and technical scores and the economy record according to the rules of the American Automobile Association. In addition to these winners

perfect scores were made by the Pierce-Arrow and Speedwell in the ninth division; the Packard and Gramm in the eighth division; the Autocar in the fifth division, the Buick and White No. 1 in the third division; and in division No. 1 by an Indian motorcycle delivery van.

The test was a 2-day affair, the first day being on the road and the second day about the streets and the hills of San Francisco. On Wednesday the twenty-two machines started from this city, crossed the bay by ferry, and made a run of 50 miles to San Jose. An hour was taken out here for luncheon and the cars then returned up the peninsula to San Francisco—the entire distance for the day being a little less than 100 miles.

Thirteen of the twenty-two cars came through this test, carrying their full capacity loads and some of them an over-load, with perfect scores.

The Franklin 1-ton truck lost its perfect score by dropping a pin out of the toggle joint. The missing pin was replaced with a twenty-penny nail and the car got along perfectly with this contrivance for the rest of the 2-days' test. In the fourth division the Grabowsky developed a leak in the gas tank. The Federal in the fifth division lost 25 minutes as the result of a broken steering arm. In the eighth division the 3-ton White No. 9 lost the water from its radiator. The motor heated and 15 minutes were lost in the search for more water. The Reliance burned a brake and had trouble with water in the carburetor. The Pope-Hartford broke its gasoline pipe line on its way to San Jose and lost 30 minutes. The Kelly dropped its pan. The Universal had motor trouble and was subsequently withdrawn. In the ninth division four of the five cars made perfect scores. The unlucky one was the Lewis, a home production, which broke a radiator spring.

At the top of the hill the cars were put through a clutch test. A platform had been built with an 8-inch curbing at one end. Each truck was compelled to place its front wheels against this and either climb it, spin its rear wheels or stall its engine. Every one of the cars succeeded in doing one of these things—proving

**TABLE SHOWING ECONOMY RECORD IN TWO-DAY TEST**  
**COST OF OPERATION**

No.	Entrant.	Class.	Running Schedule—Miles Per Hour.	Gasoline at 14¢. per Gallon.	Gasoline at 14¢. per Gallon.	Lubricating Oil at 40c. Per Gallon.	Lubricating Oil at 40c. Per Gallon.	Drivers' Wages	Depreciation 12 Per Cent. Per Annum, 300 Days	Total Cost	Total Cost Per Mile	Price of Truck	Load Carried, Pounds	Total of Road and Final Technical Examination Penalties	Cost Per Ton Mile	Total Cost Per Ton Mile, Including Penalties at 1-10 Cent Per Penalty
				Gals.	Cost.	Pints.	Cost.	Cost.	Cost.							
1	WHITE	3-K	12	10½	\$1.81	5½	\$1.10	\$2.50	\$1.92	\$ 9.83	\$.0740	\$2400	1,500	.....	\$.0987	\$.0987
3	FEDERAL	5-K	10	18¾	2.74	3	1.60	2.50	1.80	10.14	.0762	2250	2,000	550	.0762	.0803
4	WHITE	5-K	10	11	1.59½	9	1.80	2.50	2.68	11.07	.0832	3350	3,000	.....	.0554	.0554
6	FRANKLIN	4-K	12	16	2.32	3¾	.66½	4.00	2.10	13.09	.0983	2620	2,000	2800	.0983	.1194
7	BRUSH	1-K	14	5¾	.83½	3¾	.75	2.00	.36	6.02	.0452	450	500	89	.1808	.1815
8	BUICK	3-K	12	12¼	1.85	9	1.80	2.50	1.20	9.85	.0741	1150	1,500	.....	.0988	.0988
9	WHITE	8-K	6	22	3.19	11½	1.60	3.50	3.24	15.73	.1183	4050	6,000	32	.0394	.0396
10	LEWIS	9-K	6	30¾	4.47	6	1.20	3.50	3.08	15.75	.1208	3850	8,000	50	.0302	.0306
11	RELIANCE	8-K	6	28¾	4.13½	14	2.80	3.50	3.08	17.01	.1279	3850	7,000	522	.0365	.0405
13	GRAMM	8-K	6	28	4.06	16	3.20	3.50	3.11	17.37	.1306	3890	6,000	.....	.0435	.0435
14	SPEEDWELL	9-K	6	18	2.61	7	1.40	3.50	2.91	13.92	.1071	3650	8,000	.....	.0268	.0268
17	PIERCE-ARROW	9-K	6	24½	3.55½	4	.80	4.00	3.80	16.15	.1213	4750	10,000	.....	.0243	.0243
18	POPE															
	HARTFORD	8-K	6	38¾	5.58½	11¾	2.30	6.00	2.88	22.76	.1709	3600	6,000	90	.0570	.0577
19	WHITE	9-K	6	16½	2.43	10	2.00	3.50	3.60	15.03	.1154	4500	10,000	.....	.0231	.0231
20	GRABOWSKY	4-K	12	16	2.32	11	2.20	3.50	4.28	15.80	.1188	5350	2,000	20	.1188	.1189
21	KELLEY	8-K	6	29	4.20½	10	2.00	3.25	2.80	15.51	.1163	3500	6,000	6	.0389	.0390
22	AUTOCAR	5-K	10	13	1.88½	6½	1.30	3.00	1.92	11.11	.0855	2400	3,000	.....	.0557	.0557
23	WHITE	9-K	6	23¾	3.40½	5	1.00	3.50	3.60	15.01	.1153	4500	10,000	.....	.0231	.0231
24	REP.	3-K	12	12	1.74	11	2.20	2.50	.70	9.64	.0725	875	1,500	83	.0967	.0973
25	UNIVERSAL	8-K	6	With drawn	.....	.....	.....	.....	.....	.....	.....	.....	.....	.....	.....	.....
26	INDIAN	1-K	14	3¾	.49	1	.20	2.25	.36	5.55	.0417	450	250	.....	.3336	.3336
28	PACKARD	8-K	6	21½	3.15	14	2.80	4.00	3.08	17.03	.1280	3850	6,000	.....	.0427	.0427

the efficiency of their clutches. The cars were then put through a brake test on an asphalt street. The Grabowsky failed to stop within the 50-foot limit on its emergency brake, requiring 68 feet to stop. The Reo also failed on both service and emergency brakes and the Brush's emergency refused to work under 134 feet.

The purpose of the second day's events, which were held entirely in San Francisco, was to draw the attention of the San Francisco business men to the possibilities and capabilities of the motor truck. During the morning the trucks were driven over some of the worst roads in the business and residence parts of the city—the route being chosen with the view to giving the cars a test over the bad streets and hills and through some sand. Every one of them came through this part of the day's events with a perfect score—much to the delight of the truckmen. San Francisco is a hilly city and it has always been held against the motor truck that this was an obstacle to its wide use here. The



The five White trucks entered in the run made a good showing



Where the trucks checked in at one time during the two-day run



Start of the Syracuse *Herald* Sociability Run, in which fifty-five cars participated

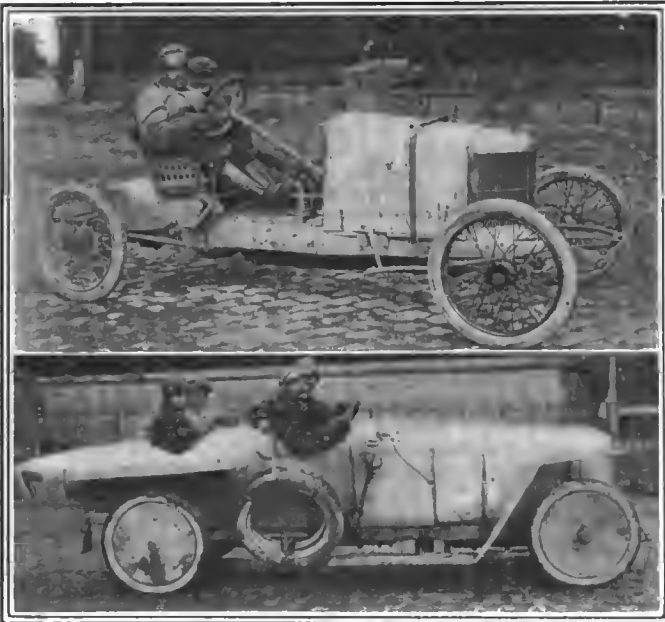

Alcyon and Benz in Gaillon Hill-Climb

score made by the trucks on this day conclusively disproved the claim that they were not able to negotiate the hills.

In the afternoon the cars were given a supreme test in hill climbing. At the end of Market street, the main artery of the city's traffic, there is a mountain which goes by the title of Twin Peaks. There is a pretty good winding road all the way to the top and over this the cars were sent. It is a steady grade all the way without a let-up and in two or three places there are inclines that are unusually heavy. At the top of the worst of these grades the cars were compelled to make a turn so sharp that they almost doubled back upon their tracks. They did all that was asked of them, grinding steadily up the hill under their enormous loads, some of them moving along at a lively clip, others moving along more slowly but unflinchingly.

Hundreds of people had gathered along the route to witness the big machines as they made their way up and they saw every one of the cars carry without protest loads that could not have been taken up by horses except with great difficulty.

## Gaillon Hill-Climb

PARIS, Oct. 5.—The French classic hill-climb, the Gaillon climb, took place on Sunday and seventy-five cars were entered. The event is over a kilometer course on the Sainte Barbe hill, and when the times are taken into consideration it must be remembered that a flying start is allowed.

The record for the hill made last year, of 23 seconds, which approximates 95 miles per hour, was not beaten and the fastest time was made by Gaste on a Rossel six-cylinder car in 32 4-5 seconds. Second in general classification was a Mors racer of 1908, which ascended the hill in 36 1-5 seconds. Third place was taken by an Alcyon driven by Barriaux, whose time was 39 1-5 seconds.

One of the cars which competed and climbed the hill in 40 4-5 seconds was a Laurin-Klement car made in Austria, with a four-cylinder motor, 3 3-5-inch bore and 10-inch stroke. It was the longest stroke car in the climb.

In addition to the speed classification the cars were subdivided into classes and awards were made for efficiency according to a formula which took the weight of the car loaded, the speed, the gradient, bore and stroke of the motor and the number of cylinders into consideration, a constant being also used, which varied according to the class of the car. Class 1 was for racing cars and class 2 for touring cars. Under the formula classification the former was won by a Lion-Peugeot driven by Goux and the latter by a Hispano-Suiza driven by Pilleverdier.

## Virginia Sociability Run

RICHMOND, VA., Oct. 14.—In a recent sociability run from Newport News, Richmond, eighteen members of the Peninsula Automobile Club motored from Warwick Hotel in Newport News to the Jefferson Hotel in this city, the average time for the 87 miles being 4 hours and 35 minutes. The first prize was awarded to H. J. Lenz, of Newport News; second M. C. Armstrong, of Hampton; third to C. T. Weaver, of Newport News. The run was not for the purpose of attaining a high speed, but the winners were determined by the three who came closest in their time to a figure selected secretly by a committee before the autoists started. The run was staged to stimulate local interest and it was very successful in this respect. It brought out a great many amateur drivers, who could not be induced to enter a severe contest.



President Taft after his arrival at Tacoma, Wash., started for Mount Tacoma. President is in second car

### Syracuse Run a Success

SYRACUSE, N. Y., Oct. 14—The annual Syracuse *Herald* Sociability run, held yesterday, was the most successful held since the event was inaugurated 4 years ago. Fifty-five machines participated in a 60-mile run through a picturesque, rolling country southwest of this city, the cars being gaily decked. The run had to be postponed a couple of times because of rain storms, and the continued interest of motorists attested the popularity of the event.

Tradition was put to rout in that car No. 13, an Overland, containing Percival C. Shaw and Mrs. Shaw, came nearest the secret time of 3 hours 35 minutes and 16 seconds, and won possession for a year of the *Herald* trophy cup. Mr. Shaw's time was 3 hours and 30 minutes. He won a solid gold medal.

The second prize, which was a loving cup from the *Herald* Company, was won by Carl Ackerman with a Flanders; the third prize, a gold medal, was won by Dr. G. N. Hemmer with a Ford; and the fourth prize, a silver medal, was taken by E. R. Harriman with a Cadillac. Miss Florence MacDonald, with a Lozier, won the first women's prize, a cup from the Automobile Club of Syracuse. Miss Mabel Walliser, with an E-M-F, was second, and Miss Jessie Greis, with a Buick, was third. They received medals. The weather was ideal and the run was enjoyed by all the participants.

### Abolish Park Racing?

PHILADELPHIA, Oct. 14—A bombshell was thrown into the Fairmount Park Commissioners at their meeting a couple of days after the running of the Fairmount Park race, when Dr. J. William White, of the University of Pennsylvania, submitted a resolution suggesting the abolishing of the Fairmount Park road race. The resolution read as follows:

"Resolved, That in the opinion of the Fairmount Park Commission, it is inadvisable to continue the automobile races in the park in future years, and that to avoid disappointment and misunderstanding this opinion be transmitted to the persons chiefly concerned, and to make the same public."

No action has as yet been taken, and public opinion may be depended upon to do the rest. Just why the ban should be placed on these yearly events is not clear; four of them have so far been held without accident, providing an afternoon of enjoyment and keen interest to hundreds of thousands who have come to look on the race as an annual fixture.

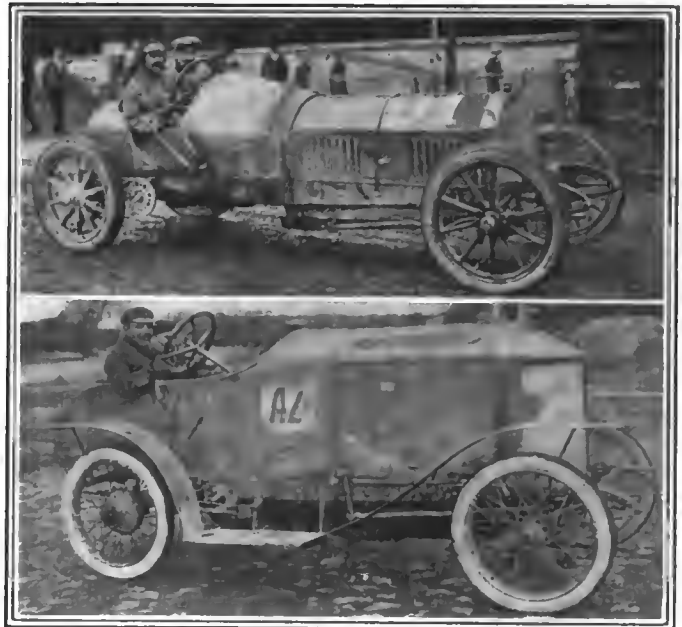

Laurin & Klement in Gaillon climb

The winning Benz car has been on exhibition in the sporting department of Wanamaker's the past week, constantly surrounded by enthusiasts and the curious.

### Detroit Conducts Sociability Run

DETROIT, MICH., Oct. 14—Twenty-one entrants contested in the under-sealed-orders sociability run of the Wolverine Automobile Club, Sunday. It was a perfect day and many of the participants took their families along. The first section of the run was from Detroit to Plymouth, 30.8 miles; the second from Plymouth to Pontiac, 40.1 miles; and the final stretch from Pontiac to Detroit, via Utica, 40.1 miles. The going was excellent with the exception of about 3 miles. C. C. Cross, of the Chalmers Motor Company, won the silver trophy offered by the Home Telephone Company, his time being just 30 minutes slower than that of the pathfinder, which was 6 hours and 45 minutes. W. E. Wilson finished second and H. J. Porter, president of the Wolverine Automobile Club, third.



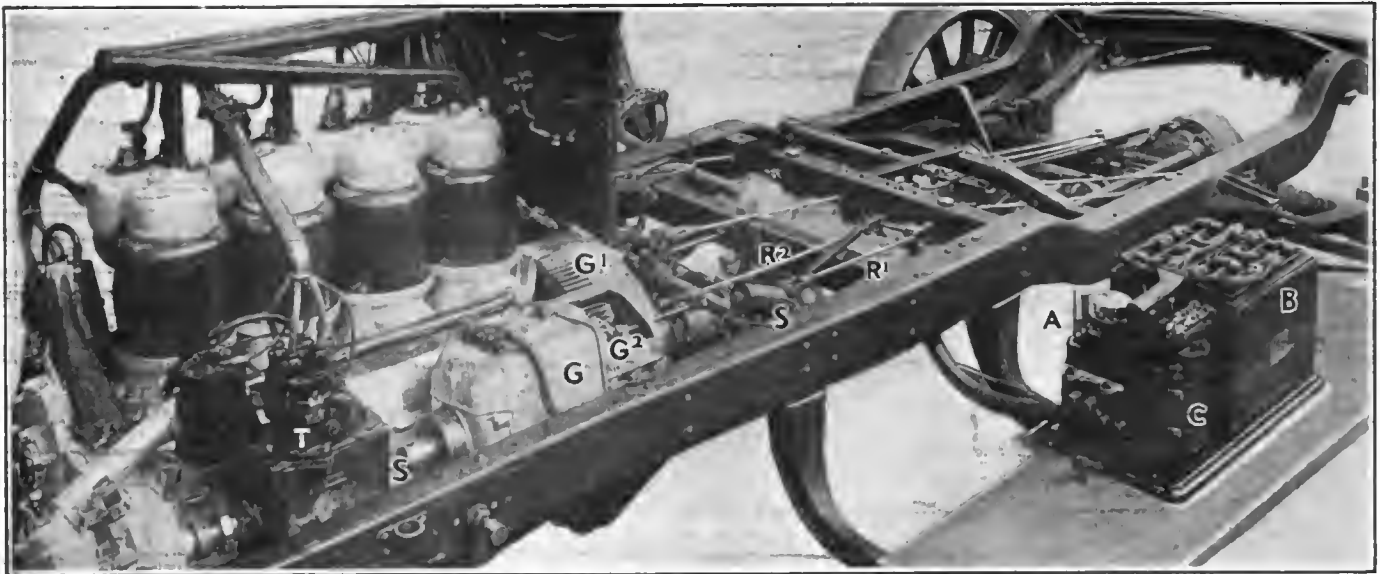

Fig. 1—Comprehensive view of the left side of the motor and the various parts comprising the self-starting device

## 1912 Cadillac Characteristics

THE new model of the Cadillac car, manufactured in Detroit, Mich., has not undergone any material alteration. Such refinements as have been deemed advisable in the light of a year's experience have been incorporated in order to render the product more efficient, but the outstanding feature of the 1912 model lies in the new self-starter effected by means of an electric motor which is capable of running both as a generator and as a motor. While running as a motor it starts the engine and afterwards furnishes current for one of the ignition systems and lights the lamps while the engine is running. The carbureter adopted for the new model has received careful study at the hands of the engineering and testing staff of the company

and it is claimed that with this and the increase in the size of the motor bore the engine is considerably more powerful.

The size of the wheels has been increased as well as the diameter of the brake drums. The magneto has been eliminated and the second speed gear ratio slightly raised.

The outstanding feature of the Cadillac motor lies in the method of casting the cylinders. It is constructed on the built-up or individual unit principle. The section through the motor seen in Fig. 4 shows that the cylinder C proper is cast by itself as is also the cylinder head H, which contains the valves. The head is attached to the cylinder by means of the threaded nipple N. The water jackets Cr which surround the cylinders

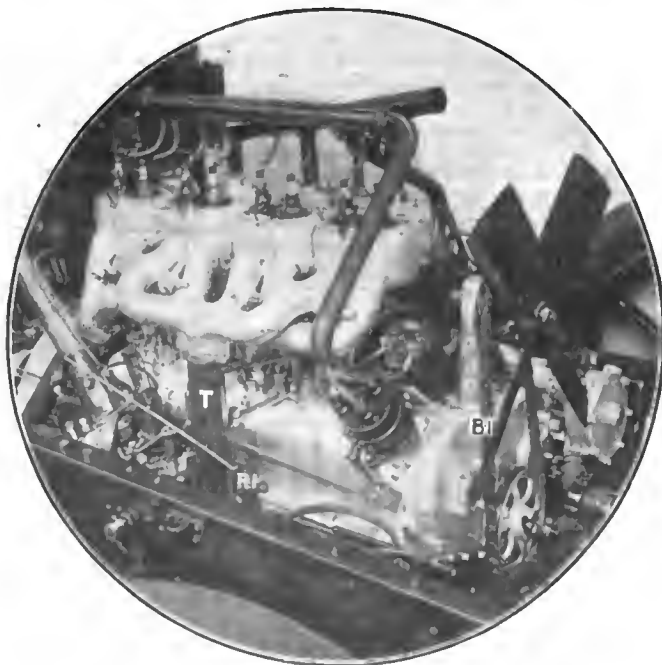

Fig. 2—Right side of the Cadillac motor, showing the new intake manifold and supplementary ignition

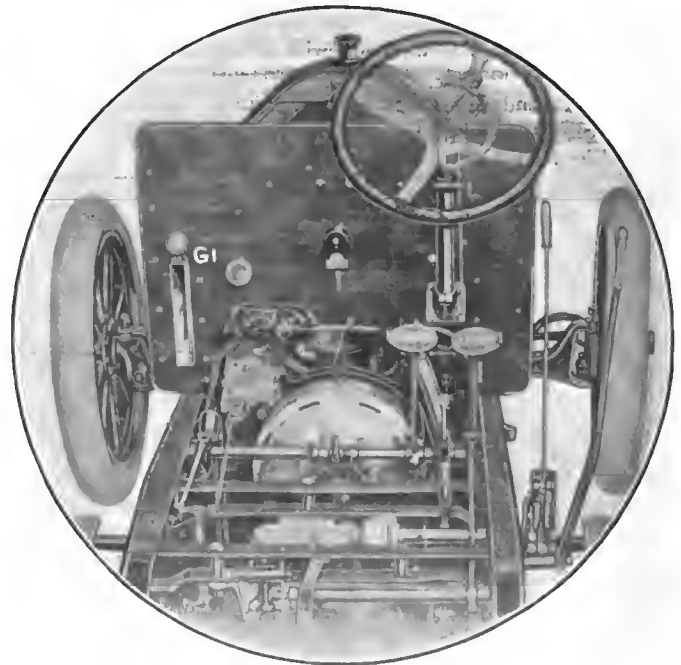

Fig. 3—Part view of the chassis, showing the dashboard and various control parts, electric generator flywheel



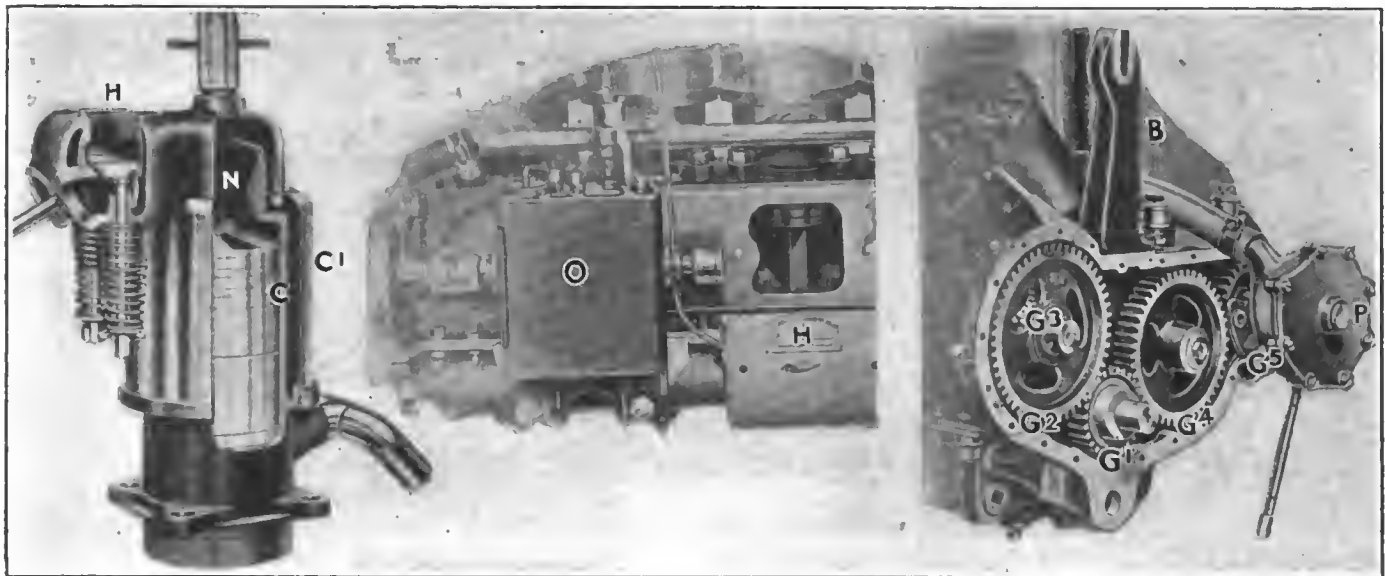

Fig. 4—One of the Cadillac cylinders with part removed

Fig. 5—Showing the oiler and hand hole in base-chamber

Fig. 6—View of the timing gears with the cover removed

are of spun copper and are clamped into position in the manner shown.

The bore of the motor has been increased from 4 to 4 1-2 inches, thereby making the motor what is termed square, the stroke of the piston being 4 1-2 inches also. The size of the valves has been increased in proportion to the bore and they are now 2 inches in diameter. A pointer is attached to the rear of the motor and together with it and the marks on the flywheel the correct setting of the valves and the ignition can be determined.

The valves are all placed on the right side of the motor, as can be seen by referring to Fig. 2, the push rods being fitted with adjustments to take up any wear from time to time.

The cylinders are first machined and afterwards ground to the correct size so that when they pass to the checkers in the controlling department there is never more than 1-1000 inch variation in the bore. Cylinders that do not conform to this strict scrutiny are discarded. The pistons and piston rings are required to pass a similar inspection and are finished by the grinding process also. The connecting rods are drop-forged steel of H-section, and the crankshaft, which is a special alloy

nickel carbon steel drop forging, undergoes a special heat treatment. The journals, 1 5-8 inches in diameter, are accurately ground and the shaft is supported by five main bearings which are made of babbitt with bronze backings. These bearings are made in halves, and should occasion require they may be removed, replaced or adjusted through the hand holes H shown in Fig. 5 without disturbing the crankshaft. The hand holes are provided with covers which are held in position by two bolts for each. The crankshaft is slightly offset; that is, instead of being placed directly in the vertical plane of the cylinders it is to one side. The object of this is to reduce the angularity of the connecting rod at the time of the explosion, thereby relieving the side thrust on the cylinder walls.

The lubrication of the motor is effected by means of an oiler placed on the left of the motor, as shown in Fig. 5. The extension of the pump shaft passes through this and drives a positive oil pump which forces the oil through a sight feed located on the dashboard. The oil is led thence to the front end of the motor into the timing gear case, whence it flows into the lower half of the crankcase, which has webs cast therein so that the oil is led into sumps under the connecting rods. These latter are

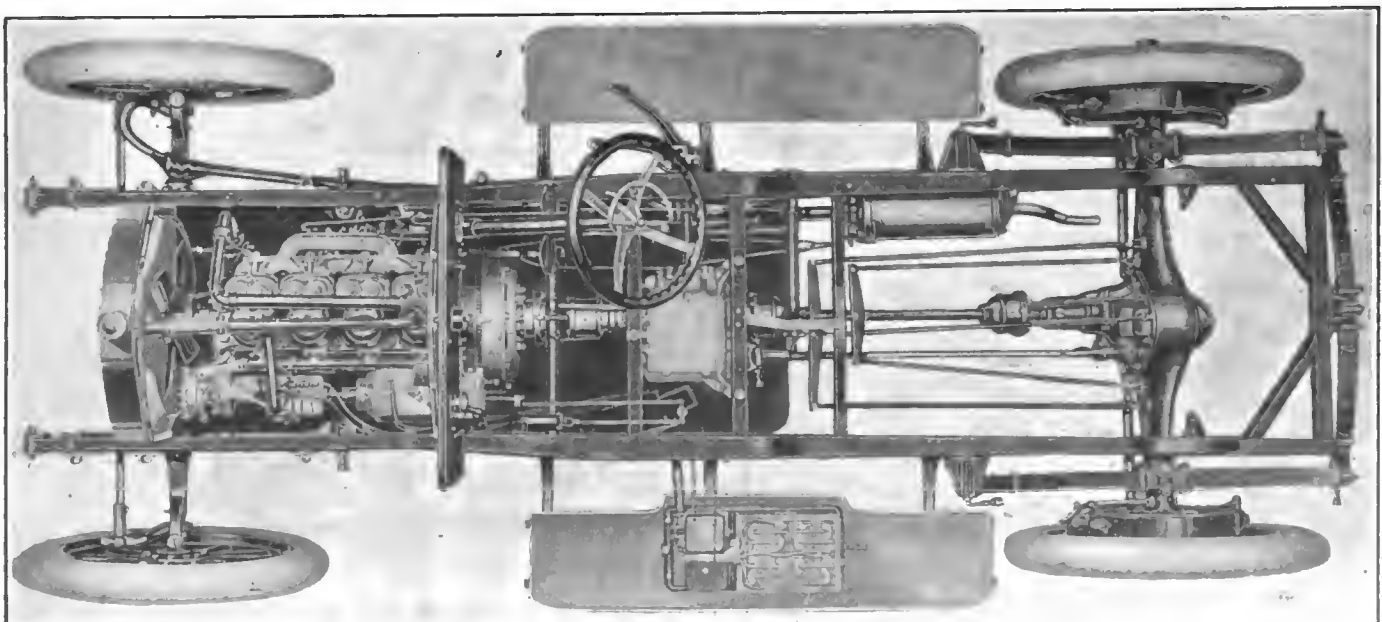

Fig. 7—Plan view of the Cadillac chassis, showing the general characteristics and the co-relation of the various parts

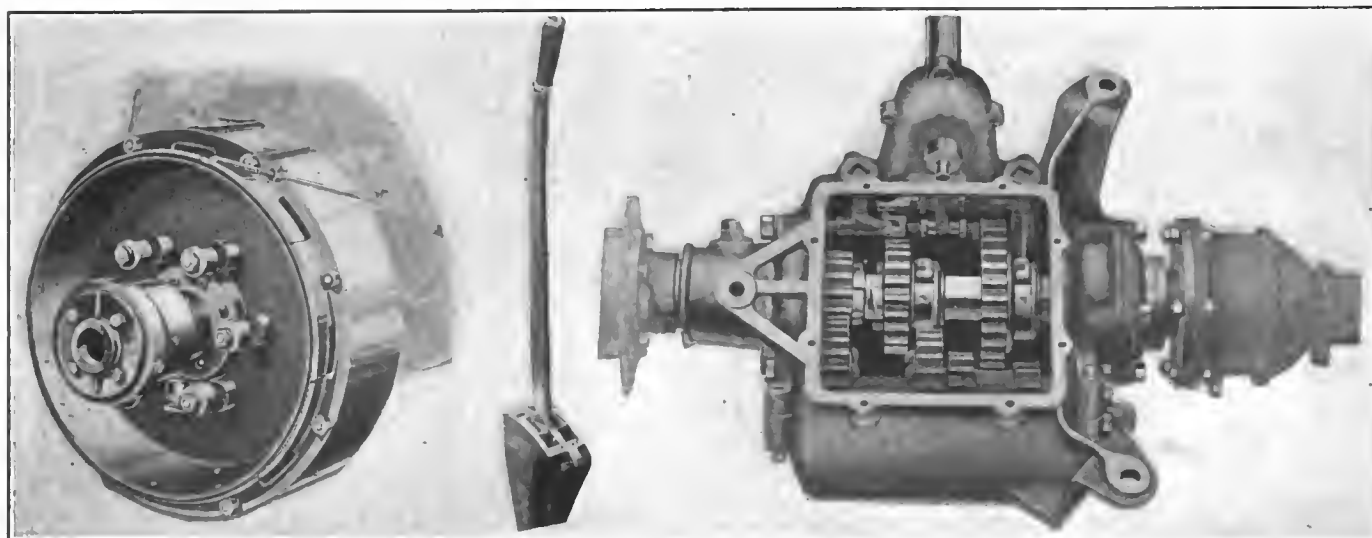

Fig. 8—View of the cone clutch showing how the ring is split for easy starting

Fig. 9—Long change-speed lever working in an H sector

Fig. 10—General view of the gear-box with the cover removed showing the method of support

fitted with extensions that beat the oil at every revolution into a spray for the splash lubrication.

The timing gears have been slightly modified and the cam and idler shafts have been extended so that a bearing can be made in the front cover of the housing. Fig. 6 shows the timing gears with the cover removed. The gear  $G_1$  is attached to the crankshaft and causes the gears  $G_2$  and  $G_4$  to rotate.  $G_2$  operates the camshaft and at the rear of this wheel will be seen the bevel gears  $G_3$  that command the supplementary ignition.  $G_4$  is an idler which meshes with  $G_5$ . This gear drives the water pump  $P$  which is placed in front of the motor, the oil pump, and the Delco ignition system as well as the generator.

The cooling of the motor is effected by means of the water pump just referred to, which takes the water from a vertical tube type radiator placed in front of the motor. The radiator is composed of 150 seamless copper tubes passing vertically through 135 horizontal copper plates and instead of dipping the entire radiator in a bath of molten solder, the tubes are treated so that only the point of contact of the tubes with the plates is covered. The air draft through the radiator is caused by a fan mounted on a bracket  $B$  in Fig. 6, wherein a slot is cut to receive the fan shaft. This is maintained in position by means of a nut and permits of easy adjustment. The fan runs on ball bearings and is operated by means of a belt  $B_1$ , shown in Fig. 2.

The carbureter is of Cadillac design and to insure good evaporation and overcome condensation troubles the mixing chamber has been made exceptionally long and is water jacketed over the entire length; this can be seen at  $T$  in Fig. 2. The lever  $L$  in Fig. 3, located on the steering column, controls a rod which alters the tension of the automatic air valve spring, giving the driver

a ready means of adjustment without leaving the seat; this can be seen at  $R_1$  in Fig. 2. The intake manifold has undergone some changes so as to give each cylinder a separate branch from the main manifold.

Two independent ignition systems are provided with two sets of spark plugs placed in valve covers, shown in Fig. 2. The supplementary set shown in this illustration is the Delco distributor system with dry cell current. Fig. 1 gives a comprehensive idea of the main ignition system, the current for which is furnished by the generator  $G$ . The timer  $T$  is driven by means of bevel gearing from the shaft that passes through the lubricator and the extension of this shaft  $S$  drives the generator  $G$ . When the speed of the motor falls below approximately 300 revolutions per minute the batteries  $B$  are automatically brought into the circuit and the generator power cut out. Above this engine speed the generator delivers the current direct to the high-tension distributor and thence to the plugs. During this time the part  $G$  acts as a generator, but to start the engine it can be used as a motor.

This is effected as follows: The driver takes his seat and presses the button on the top of the two-way switch, retards the spark and releases the clutch, which has the effect of making a magnetic contact at the point  $S$ . This causes the rod  $R_1$  to move forward and with the aid of the lever interposed the rod  $R_2$  is drawn back. This is attached to a gear wheel  $G_2$  on the generator shaft which engages with the teeth cut in the flywheel and the current flows through the transformed motor and consequently turns the engine, having an effect similar to that of ordinary hand cranking. As soon as the motor has taken a supply of gas and has fired same, by releasing the clutch pedal the

gear wheel on the generator shaft flies back and the electric motor again becomes a generator, the current from the batteries being cut out by the automatic controller  $C$ . An ammeter is provided at  $A$  to show the amount of current stored, the capacity of the batteries being 80 ampere hours, and as soon as this capacity is reached the charging automatically ceases. Some practical tests have shown that the storage battery is capable of operating the starting device and turning the engine over for a period of 20 minutes.

The storage battery  $B$  also supplies the current for lighting the head, side and tail lamps as well as the speedometer light.

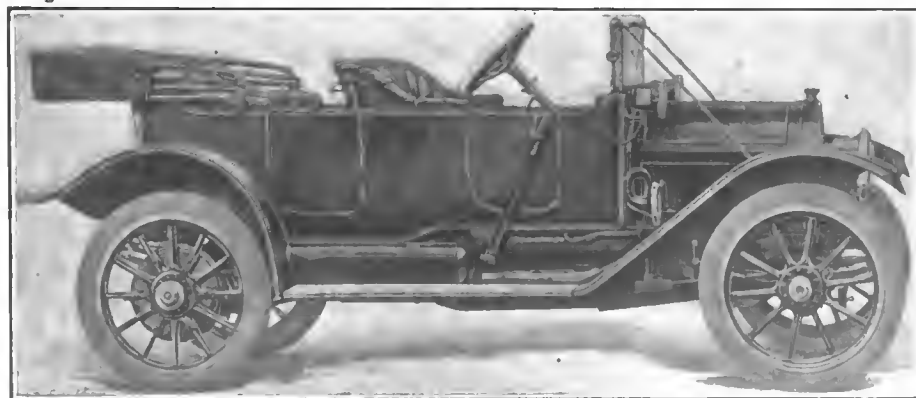

Fig. 11—Fore-door Torpedo body with the gear shift lever placed inside the body line

The motor as a unit is suspended in the chassis frame from three points, the rear of the motor base being bolted at two points to a cross member of the main frame and the forward end is provided with a rocker joint. By this means frame distortions do not affect the alignment of the motor or place any undue strains on the supporting arms.

The clutch is of the cone type, leather-faced, with a special spring ring in the flywheel, as can be seen by referring to Fig. 8. This ring, with which the cone engages, is split at eight points and part of each section is sprung inward, which has the effect of permitting the clutch to take hold gradually. Interposed between the clutch and the gear box are two universal joints entirely enclosed, thereby retaining the lubricant and excluding any foreign matter.

The transmission with the cover removed is shown in Fig. 10. It is of the sliding gear selective type, giving three speeds forward and one reverse. The gears and shafts are cut from chrome nickel steel and the clutch shaft runs on five annular ball bearings. The second speed gear ratio has been increased and attention has been paid to the method of packing the ends of the casing to prevent the leakage of any lubricant. The housing, which is of cast iron, is supported at two points at the rear to a cross member of the main chassis and at one point at the forward end. The gear teeth are backed off, or beveled, by special machinery to permit of easy engagement, and the change speed lever shown at Fig. 9 has been lengthened. It works in an H-shaped quadrant and is placed inside the fore-door.

The power is transmitted to the differential by means of a propeller shaft fitted with universal joints at both extremities, and the torque is taken care of by means of a tubular V-shaped member terminating at the forward end in a bracket attached to the cross chassis member. When the car is carrying a normal

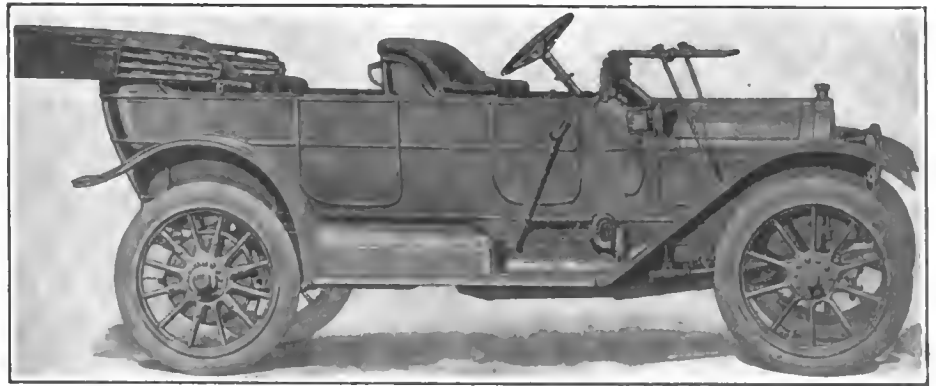

Fig. 12—Standard fore-door touring car fitted to a 30-horsepower Cadillac chassis

load the drive is practically a straight line from the motor to the rear axle. The rear axle is of Timken construction and is full floating, the drive shafts being made of special alloy steel. The general characteristics of the rear axle and the chassis in general can be seen by referring to Fig. 7. This shows the method of equalizing the service and emergency brakes, both of which operate upon the drums attached to the rear wheels. The diameter of the brake drum is 17 inches and the width of the braking surface is 2 1-2 inches, allowing easy operation.

Fig. 7 also shows the method employed for the suspension of the rear of the chassis, which is of the three-quarter platform type, the transverse spring being attached to the semi-elliptic springs by means of universal shackles all fitted with greasers. The forward suspension is taken care of by conventional semi-elliptic springs 36 inches long.

The size of the tires and wheels has been increased to 36 inches, but the wheelbase remains the same at 116 inches, the same remark applying to the tread, which remains at 56 inches.

The gasoline tank, placed under the driver's seat, has a capacity in the case of the touring and torpedo bodies of 20 gallons, and a gauge is provided on the dashboard to register the contents of the tank.

## A Rubber Revolution Promised

AT the London Rubber Show there was exhibited a piece of very excellent vulcanized rubber which had not been produced in the usual manner, it was said, but had been turned out in Brazil by a process by which the rubber was melted and cast, the vulcanization taking place during the cooling. Highly skeptic with regard to the possibility of casting rubber, as reports of similar kind have been circulated many times before, the publishers of the German *Gummi Zeitung* made inquiries in Brazil, and in due time they received a report from C. Meisel, of Para, who was at that time representing a European syndicate in negotiating with the Government of Brazil for the purchase of large tracts of land for *corrocha* plantations. Mr. Meisel stated that he had been informed by Dr. Innocencio Hollanda, of Lima, Peru, that an invention promising to revolutionize the rubber industry had really been made by a former *seringueiro* (rubber gatherer), Conrado Ramos Bastos by name, living at Portel, a small town on the Pacajá river. By his process Bastos could simply and quickly produce a high grade of vulcanized rubber from a raw material consisting of *corrucha* of many different grades mixed together. Dr. Hollanda showed Mr. Meisel three samples of the man's work; a rubber strap, 20 centimeters long, 15 centimeters wide and 2 millimeters thick, and two pieces in the form of sticks, 15 centimeters long and 1 centimeter in diameter. The color of these pieces was dark blue, and their elasticity was something marvelous. Meisel now sought the inventor and finally found him in a little adobe cabin in poverty-stricken sur-

roundings. He is a very intelligent *cobocolo*, says Mr. Meisel's report, who has worked more than twenty years as *seringueiro* in the virgin forests of the Amazon river district as well as on the Beni river in Bolivia and in Peru. During all this time Bastos has sought for means to transform the many grades of *corrocho* into a single typical raw material and also for a simplified method of vulcanization. During the last two years his efforts have been crowned with success, and lately he was requested by the Governor of the State of Para, Exm. Sur. Dr. Joao Luiz A. Goelho, to produce a number of samples in the presence of this gentleman and that of Dr. Huber, director of the Goeldi museum of Para. (Dr. Huber confirmed this by letter direct to the publishers of *Gummi Zeitung*.) The process required 3 1-2 hours, but the inventor worked with the most primitive implements, forming the molds from clay with his own hands and himself preparing the charcoal for the heating. The mixture which he adds to the melted *corracho* is his only secret, and to a representative of the Brazilian Government he is said to have stated that it is made from a substance which is found in inexhaustible quantities in all of the Amazon river valley. To 1 kilogram of *corracha* the inventor adds 1 1-2 to 2 kilograms of this admixture, and the resistance and elasticity of the product is not only not reduced thereby but increased. Mr. Meisel adds that it can only be a question of a few months before the invention must become known and practised on a large scale everywhere.—From *Gummi Zeitung*, September 8.

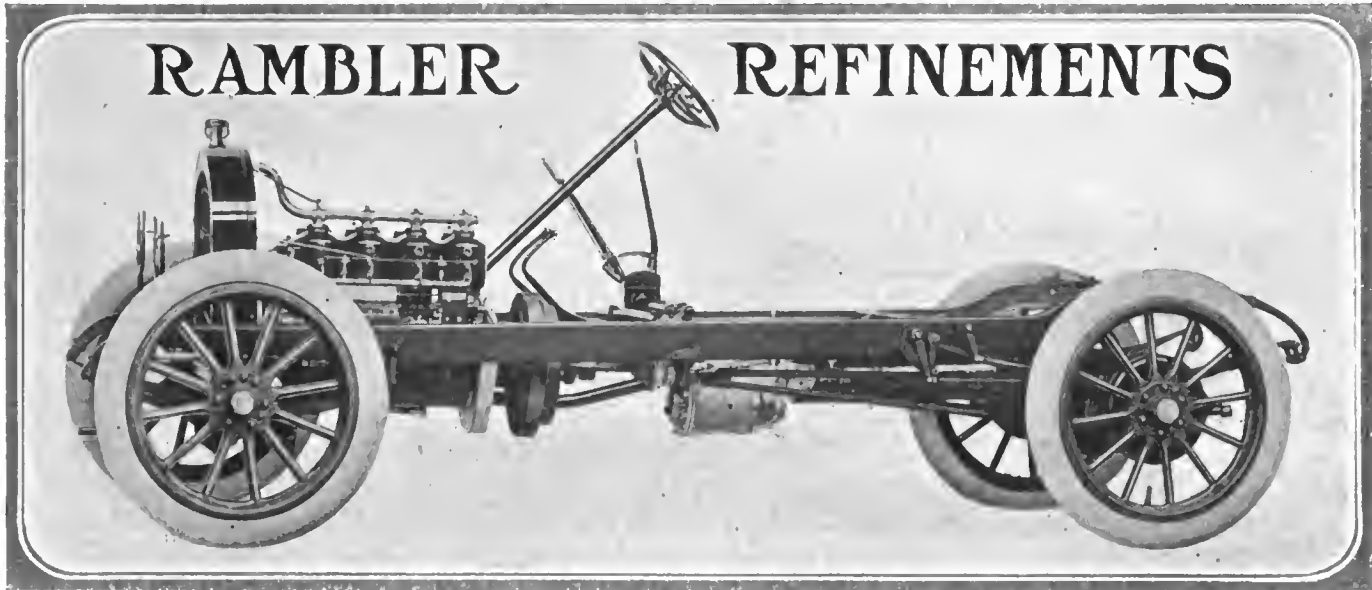

Fig. 1—Side view of the Rambler 38-horsepower chassis, showing the straight line drive and the upswept frame

THE forthcoming season's models of Rambler cars, manufactured by the Thomas B. Jeffery Co., of Kenosha, Wis., discloses a choice of four types of chassis, which with optional bodies provide eleven distinct styles.

The Rambler characteristics are retained, with several detail alterations and improvements. Among these may be mentioned a new I-beam front axle, higher radiator with increased cooling area, positive driven oiler, improved gear-shifting mechanism, a slight alteration in the clutch, strong gusset plates at the rear end of the frame and three-quarter elliptic springs to take care of the rear suspension.

In order to differentiate between the 38-horsepower and the other models that model will first be dealt with.

Each model will be known in future by a name instead of horsepower or series number, and the 38-horsepower model is fitted with three styles of body work. The Cross-Country is fitted with a five-passenger touring body, the Suburban with a four-passenger torpedo and the Roadster, as the name implies, with seating capacity for two.

The wheelbase of the 38-horsepower models is uniform, being 120 inches on all, and the present trend for large wheels has been followed by providing 36-inch wheels fitted with 36 x 4 inch tires.

The front of the car, which is usually the characteristic feature of any automobile, has been materially altered, as may be seen by referring to Fig. 5. The height of the radiator has been increased and a higher filler cap mounted upon it, the contour of the top being given a decided arch. The I-beam front axle is also shown in this illustration, with the cross bar coupling the steering arms placed in the rear of same. Taper roller bearings are employed throughout, both

for the wheels to run upon and to take up the thrust of the steering knuckle pins. The starting handle shaft is extended forward so as to clear the dumb irons, two brackets, A1 and A2, being provided to form the outboard support.

Detachable wheels, a feature of Rambler cars, is still retained, but instead of being provided in the general equipment, as heretofore, it is now supplied at a slight extra charge. Provision has been made to carry this part at the rear of the body in the manner shown in Fig. 6, instead of on the running-board, as formerly.

The power plant shown in Fig. 2 discloses several alterations over previous seasons' models. The method of casting the cylinders has been retained; likewise the connection of the joints for the water manifolds. The bore and stroke of the 38-horsepower motor is identical—4½ inches—and the cylinders are cast with L-shaped heads. Some alteration has been made in the arrangement of the timing gears, as well as in the housing. Instead of having the water pump in front of the motor, this part has now been placed nearer to the cylinders and is driven by the half-time shaft, the forward end of which protrudes through the timing gear case shown at T, and the pulley P for driving the fan belt is attached thereto.

The water pump may be seen at P in Fig. 2, and a drain cock D is fitted in the base for emptying the water in cold weather or when it may be found necessary. Packing glands are provided at the forward and rear portions of the body of the pump where the shaft passes through.

The continuation of the shaft drives a pump in the oiler O, forcing the oil into the sight feeds S and thence from seven leads—three to the main bearings of the crankshaft and one lead to each cylinder. The method of driving

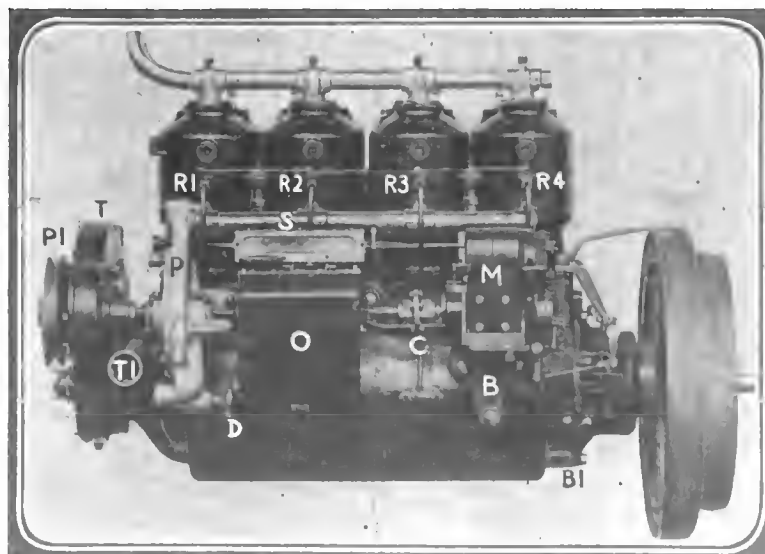

Fig. 2—Side view of the motor, showing the water pump, oiler and magneto



the oiler differs from previous practise, and the magneto M has been placed farther back and is driven by a continuation of the pump and oiler shaft. Interposed in the drive is a universal jointed coupling C, which, besides insuring that disalignment shall not cause any strain on the armature shaft, allows the magneto to be readily removed. Access to the magneto is obtained either by lifting the hood or through a trap door provided in the floor boards.

In Fig. 2 is shown the method of supporting the motor. The tube T1 is built up with the motor base and terminates at either side of the chassis frame in suitable clamps bolted to the side members. By removing the nuts that hold these clamps in position the latter can be slipped over the tubes sufficiently far to clear the frame. A cross

member of the frame passes beneath the rear of the motor at the point B1 and bolts pass through it, clamping the rear of the motor in position. A feature of Rambler design lies in the straight line drive from motor to rear axle, and to obtain the requisite amount of slant to the motor, babbitt is run in between the motor base and the cross member until the correct alignment is reached.

Compression release cocks R1, R2, R3 and R4, are fitted to permit of easy starting, the residue of compression being carried by small copper pipes to the side of the motor and the operating lever controlling the cocks is placed on the side of the radiator.

Ignition is furnished by a high-tension magneto, the position of which has already been described. Carburetion is effected by means of a Holley carbureter and a manifold of improved construction, doing away with the loops over the motor.

The clutch shown in Fig. 3 has also undergone some minor changes, although in principle it is virtually the same as that adopted last year. It is of the internal expanding type and operates inside the fly-wheel. The clutch pedal and arm force the arms A1 and A2 forward, which has the effect of rocking the arm

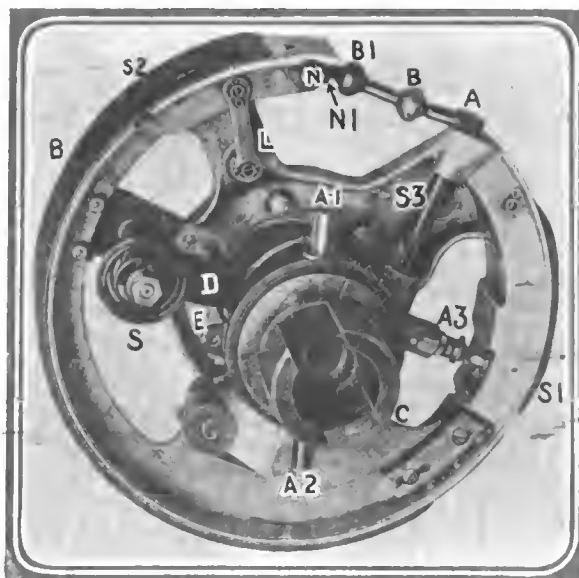

Fig. 3—Details of expanding clutch, showing the two adjustments

D so as to relieve the tension of the spring S. At the same time the action of the part D causes the shaft S3 to rotate slightly, sufficient to rock the arm A, which commands the ball sockets B and B1, thereby contracting the band B, which is attached to the shoe S2.

The adjustment of the expansion of the clutch is effected by means of the nut N1, which is locked in position by the set-screw N. The lever L prevents the shoe S2 from swinging back and causing abrupt engagement, as well as the shoe S1, which is operated by a small toggle joint A3 at the same time as the main body of the band B. This latter part is also fitted with a means of adjustment. The drive is taken by the collar C, which engages with the forward end of the shaft, communicating the drive to the gear box. The

arms A1 and A2 form part of a ball-thrust collar, which is held in position by a tie rod from the main frame to the eye E and lubricated by the greaser G. When the clutch pedal is released the expansion of the band is maintained by the spring S.

The plan view of the chassis, Fig. 4, shows the general assembly of the motor, clutch, gearset and rear axle, and Fig. 1 gives an idea of the straight-line drive. The gear-box is attached at its forward extremity to the central cross member of the frame and the aluminum housing of the gear-box is cast on to the tube surrounding the propeller shaft. The main shaft of the gearset is a continuation of the propeller shaft and the change of gear is now effected by a straight-line pull upon the shifting rods. Two arms attached to these are fitted by means of brackets to the propeller shaft casing, as may be seen in Fig. 4. The change-speed lever, as well as the brake lever, have been placed within the body line, and as the gears are of the selective type, the gear-shift lever works in an H-type sector. Three forward speeds and reverse are provided.

The final drive is by live rear axle, the weight of the load being taken upon roller bearings. The drive shafts and the gears are forged integral and the road wheels are secured to

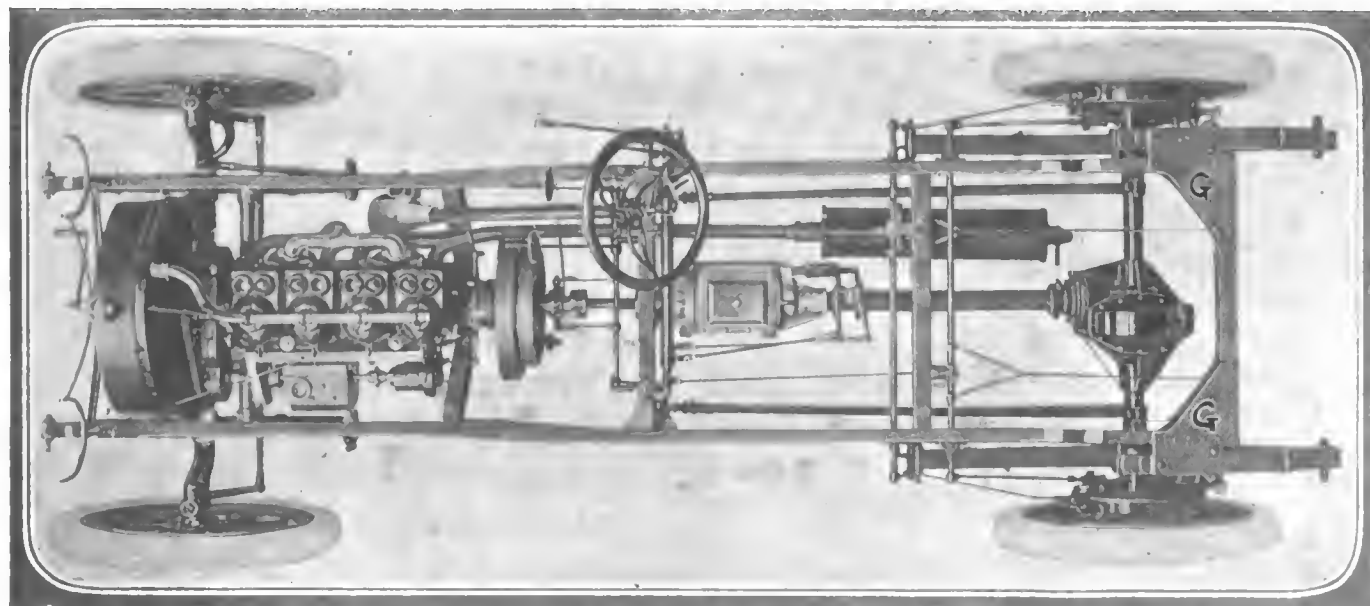

Fig. 4—Plan view of the Rambler chassis, showing the co-relation of the various units



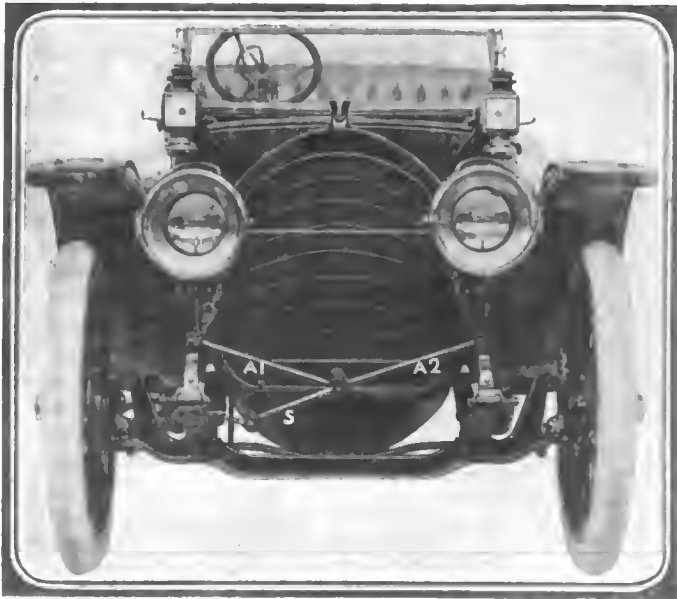

Fig. 5—Front view of the new Rambler, showing the radiator and the out-bound supports for the starting handle

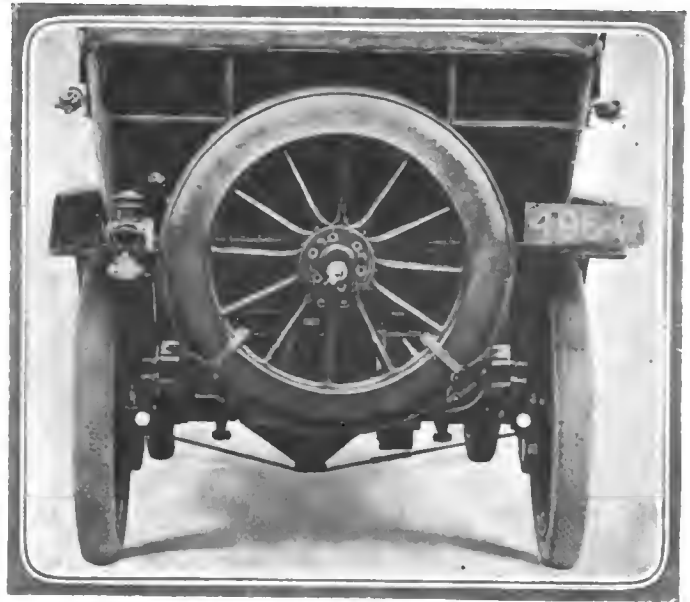

Fig. 6—View of the rear of the car, showing the method employed in carrying the spare wheel

the ends of the shafts by means of squared taper ends. Stout gusset plates have been incorporated in the construction of the rear end of the frame, as shown in Fig. 4, the extensions of which form the anchorage of the top brace of the three-quarter elliptic springs. The torque of the rear axle is taken up in the two radius rods, terminating at their forward extremities in ball sockets, permitting of a certain amount of angularity without causing any binding effect.

Two sets of fully equalized brakes are provided, both operating upon the brake drums attached to the rear road wheels.

The essential features described above apply in general to the 50-horsepower models, the motor of which has a bore of 5 inches and a stroke of  $5\frac{1}{2}$  inches. Dual system of ignition is employed, and in the case of the Metropolitan, Greyhound and Moraine, the size of the wheels is 40 inches in diameter.

The Country Club, Valkyrie and Moraine are fitted to one type of chassis, having a tubular front axle and seven-eighths elliptic spring suspension at the rear. The first two of these are fitted with 36-inch wheels and have a 120-inch wheelbase; the Moraine, which is a seven-passenger touring car, has 128-inch wheelbase. The Metropolitan, a seven-passenger touring car, and the Greyhound, a six-passenger, are fitted with three-quarter elliptic springs and have a wheelbase of 128 inches.

The Rambler closed-car line includes the Knickerbocker, a seven-passenger limousine of the Berline type; the Sedan, a four-passenger with closed cab seats, and the Gotham, a five-passenger limousine with cab sides.

The standard coloring of the majority of the Rambler body types is an English purple lake with black beads striped in car-

mine, with the metal furnishings nickel finished. The fenders and valance fillers are japanned black. An option, however, is given in the majority of styles for the customers who prefer a lighter coloring, and for these Brewster green can be furnished, as also can a certain shade of gray, known as Rambler gray, in the case of the Roadster.

The equipment of the cars includes head lamp with gas tank, side lamps, tonneau hinged robe rail, adjustable foot rest and complete set of tools. The Roadster has a trunk with suit cases placed on the rear platform. The interior of the closed cars is trimmed in Bedford cord and some of the fittings include silk blinds on automatic rollers, electric dome light in the ceiling, toilet case and speaking tube.

## Winter Storage of Car

WHEN the use of the car is given up for the cold weather season, the car should be jacked up off of the tires, some air let out of them so as to reduce the pressure, and the whole washed very thoroughly, particular attention being paid to the removal of all traces of oil. Water does not harm the tires or the rubber composing them in the least, but oil and gasoline do. In case it is desired to go into the matter a little further, and do a more thorough job of putting them up for the Winter, proceed as follows:

After washing thoroughly, take the tires off of the wheels, take the tubes out of the shoes, paint the inside of the shoe and the outside of the tube with graphite, wrap both very carefully in cloth or heavy paper, paper over cloth being the best, then store in some dry, dark place, preferably where the temperature is very even all Winter and not far from 30 degrees Fahrenheit. Light is a great enemy of rubber, as is also heat; by putting the protective covering around the tires, then keeping them away from light and heat, there will be absolutely no deterioration, no matter how long they may be kept put away. This method of procedure is really worth the time it takes. Of course, none of the ordinary oils used for paint bodies would be suitable for this purpose, as they would rot the rubber. What is meant by painting with graphite is that it should be applied in its powder form.

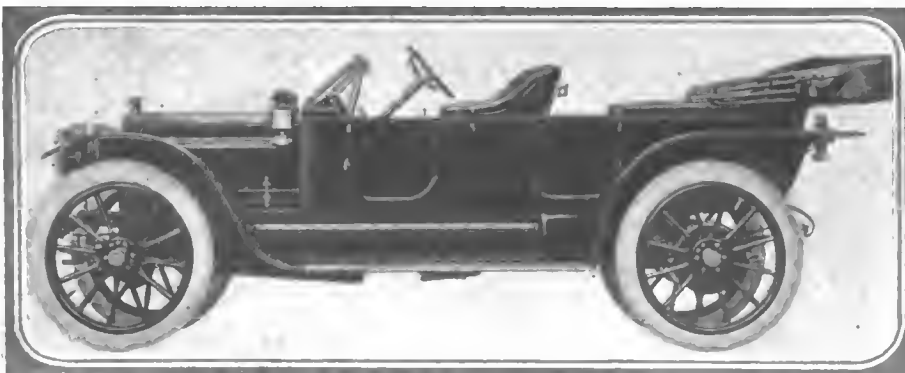

Fig. 7—General appearance of the Greyhound Rambler with fore doors and sloping cowl

**PREVENTABLE BREAKDOWNS**—There are road breakdowns which, although apparently not the fault of the car owner or driver, will on examination show that they could have been prevented if proper precaution had been taken. One instance which may be taken is the damage which ensues from a broken ball in a bearing. The breakage of other balls and the grinding of the race could have readily been prevented by even a casual inspection before starting upon the trip. Cleaning the ball bearings in order to remove every particle of grit from the race is as essential as the lubrication of the bearing. No one would think of allowing a bearing to run without oil, yet many neglect the cleaning of the bearings, an operation that is in every way as important, even though it is never required more often than about once in two weeks. Many a trifling knock which would have soon developed into something serious, and many an impending stripped gear has been forestalled at an expenditure which is far less than it would have been if the owner had waited until the accident had occurred. The car should never leave the garage without the full confidence of the owner that it is in the best state of repair and adjustment and that it is clean.

### Among the New Books

**TEXT BOOK OF THE ELEMENTS OF MACHINE WORK.** By Robert H. Smith, Massachusetts Institute of Technology. Published by Industrial Education Book Co., Boston, Mass. 192 pages, 5 x 8, 204 illustrations. Cloth, \$2.00.

The fundamental principles of bench work have been taken up in this copiously illustrated book as well as the elements of machine practice and mechanical drawing. The book consists of 371 numbered paragraphs, each headed by a topic sentence in bold-faced type. A classified table of contents and an alphabetical index guide the reader or student in his perusal of the work or in his search for a particular item.

The book is complete enough to be used as an elementary reference work for the apprentice or student of shop practice. A table of decimal equivalents concludes this useful book, which will no doubt find favor with those interested in the subject matter treated.

**QUESTIONS AND ANSWERS FOR AUTOMOBILE STUDENTS AND MECHANICS.** By Thomas Russell, A.M., M.E. Published by The Charles C. Thompson Co., Chicago. 150 pages. Leather, \$1.50; cloth, \$1.00.

While undoubtedly a book intended only for students of automobiles and automobiling, its completeness would justify a posi-

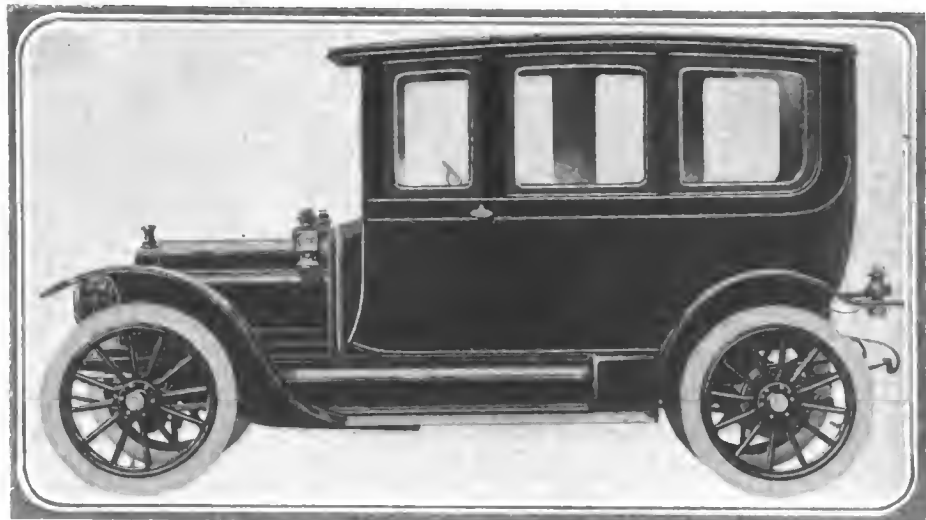

Fig. 8—Side view of the sedan body fitted to a Rambler Chassis with a single door

tion in any library on this interesting subject. The questions are terse and are answered in such a way that there is no doubt as to the meaning intended. Mr. Russell, who has written other works on this and kindred subjects, has aimed to bring out the salient features in each part upon which he has touched, and he has done so, as will be demonstrated by a perusal of the work.

A separation of the questions and answers renders the book very satisfactory for self-instruction, and by its completeness it is made fully capable of being used as a text book. Its scope is very wide, taking up first the motor car in general and then covering the different essential details.

**TEXT BOOK OF THE PRINCIPLES OF MACHINE WORK.** By Robert H. Smith, Massachusetts Institute of Technology. Published by Industrial Education Book Co., Boston, Mass. 388 pages, 5 x 8, 434 illustrations. Cloth, \$3.00.

The uses of the various tools connected with the various operations at the bench and at the various machines are here brought to the reader in a clear and concise form which will be very much appreciated by the student of machine work. The work is profusely illustrated in such a manner that the methods of carrying out the operations are brought vividly to the mind of the student. The methods of making the calculations involved in practical work are also shown and typical examples given to augment their usefulness.

As a reference work this book should have as large a field as when used as a text book since it is very complete so far as the ordinary shop undertakings are concerned and is well indexed. A set of tables and data of a very useful nature conclude the work.

**AUDEL'S ANSWERS ON AUTOMOBILES.** By Gideon Harris and Associates. Published by Theo. Audel & Co., New York. 476 pages, 380 illustrations. Cloth, \$1.50.

In this work a very complete set of questions and answers are furnished. The topics dealt with range from questions and replies on fuels to information on the driving and mechanical arrangement of the automobile.

Each chapter is introduced by explanatory remarks on the subjects contained therein, and is amply illustrated. The book as a whole is very satisfactory and will no doubt find its way into the libraries of those who wish a concise, well-written book treating of the details of the construction and upkeep of the automobile.

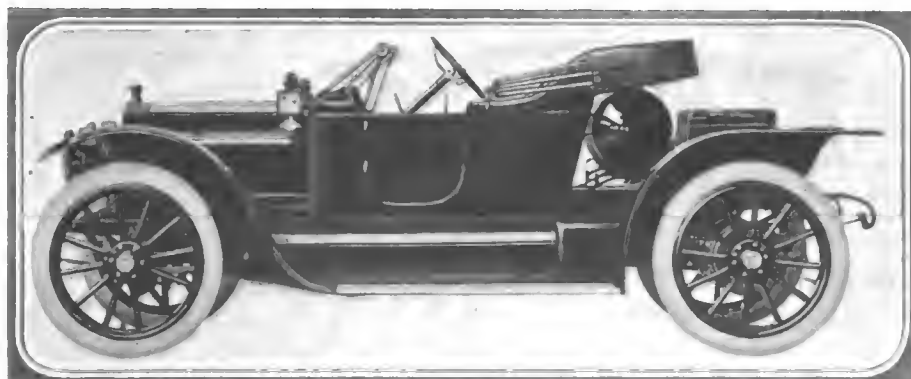

Fig. 9—Side view of the fore-door Rambler with gasoline tank placed behind the driver's seat as well as the trunk with suit cases



Fig. 1—The C. I. M. A. tractor has a motor with 10-inch bore and 15-inch stroke

## Adapting the Motor to Farm Uses French Agricultural Motors

**A**UTOMOBILE clubs in France are finding a large field for work in arranging trials for agricultural motor machinery and implements. In a contest recently held at Roubaix by the Automobile Club de France in co-operation with the Automobile Club du Nord and the Association of French Manufacturers of Agricultural Implements, the machines submitted for test were two tractors, the Cima and the Lefebvre, made at Rouen; a motor plough made by P. Gilbert, Paris, and another motor plough made by Landrin of Soissons. Both the ploughs are of the revolving-disk type. A Linard-Hubert motor plough had also been entered, but was prevented from taking part in the trials. According to the report rendered by the committee on agricultural machinery of the Automobile Club de France, the features considered in the contest by the judges were: First, the execution of the work; second, the cost of the fuel or energy (electric current) consumed in tilling 1 hectare of land (1 hectare equals 2.471 acres); third, the time required for transportation and getting ready; fourth, the number of workmen necessary for operating the implement; fifth, the facilities for using the implement under different conditions of soil and surface, and, sixth, the possibility of utilizing the motor of the implement for other agricultural work.

To obtain a basis for comparison among the different machines all of them were required to work at a minimum depth of 15 centimeters (5.906 inches). The fields used for the trials on the first day were in stubble, while those worked on the second day had been turned over, and the soil was found particularly hard and dry, being thin with a clay subsoil, which rendered it necessary to make the furrows relatively shallow. The agricultural experts pronounced the conditions highly unfavorable. The shape and size of the fields necessitated too frequent half-turns for machines especially intended for work on large farms, and the cost of the work per hectare was considerably

increased by this condition. It was ascertained that the strip of land left untilled at the edge of the fields, by reason of the space required for turns, reached a width of 36 to 45 feet in the case of the Cima tractor, 45 feet for the Lefebvre tractor and 6 to 15 feet for the two ploughs. In the case of the ploughs this width of waste area may be further reduced by backing them up, with the rotary disks raised. The time used in making a turn, counting from the finish of one furrow to the beginning of another, was 1 minute 20 seconds for the Cima tractor (also known as the Osborne, being apparently of English or American origin), 2 minutes for the Landrin plough, 2 minutes 30 seconds for the Lefebvre tractor, while the Gilbert plough drew a continuous furrow, describing a rectangle with rounded corners.

The Cima obtained the gold medal of the Association of Automobile Manufacturers and the silver medal of the Association of French Manufacturers of Agricultural Machinery. The Landrin got the silver-gilt medal of the Department of Agriculture and one-half of the prize offered by the Agricultural Society of France; also the silver medal of the A. F. M. A. M. The Lefebvre got the silver-gilt medal and the other half of the prize of the Agricultural Society as well as the silver medal of the A. F. M. A. M. The Gilbert finally obtained the silver medal of the Department of Agriculture and the silver medal of the Agricultural Society.

Several mechanics connected with the trial received individual awards.

The contesting machines, some of which are shown in the accompanying illustrations, are described by the club committee substantially as follows:

The Cima, or Osborne, tractor carries a 25-horsepower horizontal motor with two flywheels, of the type ordinarily employed for industrial purposes, and the power of the motor is transmitted to the two large rear wheels by trains of gears thrown into engagement by a friction clutch. The small front wheels are steered by chains from a steering post at



Fig. 2—Landrin rotary-disk plough and tractor

the rear of the vehicle, so that the driver at the same time can watch the course of the tractor and the operation of the plough. The motor cylinders are of 254 mm. (10 inches) bore and 381 mm. (15 inches) stroke. The crankshaft speed varies from 230 to 290 revolutions per minute, and the diameter of the flywheels is 1.33 meter (4 feet 4 inches). The driving wheels measure 1.75 meters (5 feet 8¼ inches) in diameter, with a tire width of 0.55 meter (1 foot 9½ inches). In case of excessive humidity in the soil extension rims can be put on the driving wheels, bringing the tire width to 0.75 meter (2 feet 5¼ inches). The all-over measurements of the tractor are 4.96 meters (16.5 feet) in length and 2.46 meters (8.2 feet) in width. In the trials the plough drawn by the tractor was a Mogul with five shares, any one of which can be raised and taken out of use independently, and the moldboards are arranged to raise themselves if a rock in the ground or other obstacle is encountered. The Cima requires three attendants for operation with a plough.

The Landrin rotary-disk plough or cultivator (Fig. 2) comprises two distinct parts, the motor chassis and the cultivator chassis. The motor chassis differs from an ordinary automobile chassis in the following features: The driving wheels are equipped with movable cleats (traction ribs) mounted around an eccentric which serves to either push the cleats out from the surface of the wheel rim or to draw them back, the eccentric being so placed that the cleats project from the rim where the latter is going, into contact with the ground and recede when the contact has taken place. The object is of course to increase the adhesion, but also to remove automatically the soil which may cling to the cleats. By means of a suitable displacement of the eccentric the action can be reversed, so that the projecting ribs recede at the point of contact with the ground, and this facilitates the travel of the cultivator on hard roads. The motor chassis supports a winch intended to raise the cultivator chassis by means of a cable, and a worm gear renders this winch irreversible. The conductor can throw the motor shaft into gear with the winch by means of a lever within his reach, and thus by a single movement stop and resume work, as at turns.

The cultivator chassis is triangular in shape, and the base parallels a shaft on which four steel disks are secured, and the apex of the triangle is connected with the motor chassis by means of a



Fig. 3—Gilbert's plough combined with tractor

joint which admits of all movements except forward. The disk-actuating shaft is similarly articulated by means of a cardan joint. The disks themselves are shaped as segments of a sphere and are mounted at equal intervals, the shaft being placed at an angle with the driving wheel shaft varying from 20° to 40° and subject to adjustment according to the position given a bar, provided with various adjustment holes, which connects the cultivator chassis with the hub of the right-hand driving wheel. The depth of the disk action in the soil may be regulated by two rollers and two threaded rods supporting each one end of the disk shaft.

Gilbert's self-propelling plough Fig. 3 is meant for doing all the work in preparing soil for seeding, and the designer has had in mind to accomplish this purpose with a relatively light construction, while providing means to prevent the oblique thrust of the rotating disk from influencing the direction of the machine and also for enabling the driver to watch and regulate the operation of the machine. Of the two rear wheels only the one on the right-hand side is a driving wheel, the left one serving only for support. The front axle is secured to the chassis by a system of joints in such manner that the steering wheels may follow all the inequalities of the soil without changing the horizontal position of the chassis, and the wheels are offset to the right, so that the driving wheel tracks the width of one furrow to the left of the right hand front wheel. The disk, in the shape of a spherical segment, is secured to the chassis between the front and rear wheels by means of an arm, and a transverse shaft around which the arm turns when raising or lowering the disk may also serve as axle for the left rear wheel, this being the method adopted for securing a horizontal position of the chassis, when the machine is at work as well as on the road. The motor drives the disk as well as the driving wheel. The mechanical connection with the disk is effected by a spurwheel and a bevel pinion, running in a casing, and the pinion is connected with the vehicle transmission by a removable chain, so that a simple play of gears permits the driver to adjust the speed of the disk to the nature of the soil and the rate of progress of the vehicle. On the road the chain may be removed. The disk turns in the direction opposite to the movement of the vehicle and at a superior speed, with a view to turning the soil over in a work-

(Continued on page 683.)



Fig. 4—The Linard-Hubert tractor with its detachable ploughing equipment

# Letters Answered and Discussed

## Measuring Compression Space

EDITOR THE AUTOMOBILE:  
 [2,868]—Would you kindly inform me if there is any gauge which is made for the purpose of measuring the compression space in the different cylinders to ascertain whether it is the same in all of them?

(2) What would be the results which would arise in case these compression spaces were not equal?

(3) How is it possible to determine when the piston on a certain cylinder has reached the top of its stroke?

I have a four-cylinder motor of 30-horsepower and I wish to ascertain if the compression is the same in all the cylinders, as the motor has been run for a considerable length of time and I am afraid that there has been considerable wear.

CARL KEISER.

Portland, Me.

(1) A gauge which will be familiar to any one who has worked about a carpenter shop to any extent may be used to advantage in measuring the piston clearance of the cylinders. The gauge and the manner of inserting in the pet cock aperture are shown in Fig. 1. The motor is slowly turned over, and when the spindle has been pushed by the piston as far as possible through the cross piece of the gauge, which is held flat against the top of the cylinder, a reading may be taken off the spindle and the clearance of the piston plus the thickness of the walls and water jacket space will be given. A note is made of this reading or the gauge may be nicked at the point where the gauge registered with the cross piece. This can then be checked in the

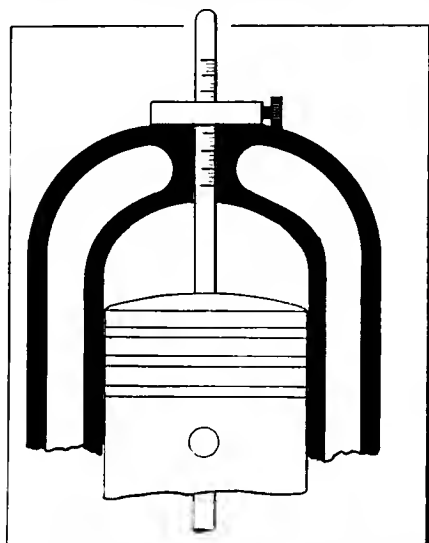

Fig. 1—Gauge used in testing the compression space in the motor

other cylinders and should agree exactly.

(2) In case the compression spaces differed the motor would be out of balance and the impulses on the cranks would differ in force. Vibration and rocking of the motor on its foundations would be the natural result of the unbalanced forces.

(3) The piston has reached the top of the stroke when it ceases to push the gauge. There are very often marks on the flywheel which denote the dead centers of the engine when they register with marks on the frame of the motor.

The fact that your motor has been run

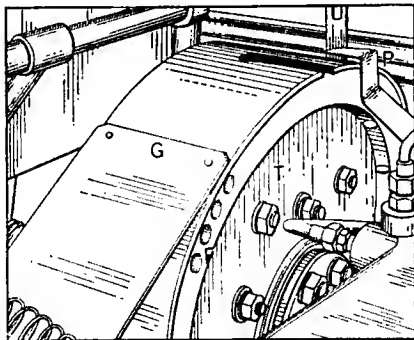

Fig. 2—Guard placed over the flywheel to prevent oil slinging

for a long time does not indicate that there has been any change in the relative compression space, as whatever wear there has been will no doubt have equalized itself by wearing the corresponding parts in all the cylinders a like amount. If there is anything wrong with the compression it will probably be in the nature of a worn valve seat or valve which needs regrinding or in leaky plugs and other openings into the cylinder.

## Needs Mud Guard

EDITOR THE AUTOMOBILE:

[2,869]—I am driving a truck and am much troubled by the oil being thrown about by the flywheel. Could you tell me of a method of stopping this? The oil will leak up through the floor boards and completely soak through anything which happens to be resting upon them. Besides this the dirt will adhere to the oil and cause a great deal of trouble in keeping the truck clean.  
 M. F.

New York City.

A mud guard such as is indicated at G in Fig. 2 should be fitted. This consists of a flat piece of tin which is carried across the flywheel and fastened to the chassis frame by means of bolts. A groove is cut as shown in the guard, so that the mark-

ings on the flywheel will be visible below the indicator P and when setting up the engine the correct timing may be maintained without trouble.

## Fitted New Carbureter

EDITOR THE AUTOMOBILE:

[2,870]—I have a 1906 car which I have changed over to a jump spark and have also fitted a new make of carbureter. It runs very well on level ground and takes most hills on high speed. But sometimes when taking a long one on high speed it will choke up and fire only on three cylinders. After the engine has been allowed to speed up by throwing out the clutch, when the top of the hill is reached, it will once more hit on all four cylinders. Could you tell me the trouble?

2. What was the horsepower of the car which won the 1910 Grand Prix?

New York City. A. E. W.

The probabilities are that you have used a carbureter too small for the engine to which you have fitted it. You are not getting enough air and too much gasoline.

2. The horsepower of the car which won the 1910 Grand Prix was 120 by the maker's rating and 63 by the A. L. A. M.

## Deprecates Crowned Roads

EDITOR THE AUTOMOBILE:

[2,871]—In your paper for September 28, under the heading "Good Roads," I could not but notice the favor shown for crowning roads for the automobile. In Los Angeles they are doing their best to build good roads of which our people are justly proud. But the crowned roads are not good nor safe for automobiles; any road that is too much crowned for horses is too much so for automobiles, and that is not all. In California we are compelled to keep to the right of the center of the road and as near to the gutter as practicable. Consequently the right side of the machine, being several inches lower than the opposite side, must support a greater amount of weight. The result is that the tires on the side next to the gutter give out much more quickly than the tires on the opposite side of the machine.

Many cars are not absolutely grease-proof, and the right side of the machine running on the lower incline causes the grease that works out from the differential to find the lower level, thereby interfering with the brake and in some cases dropping out and finding its resting place on the tire, while on the opposite side of the machine the brake shows no sign of superfluous



grease. The springs also show wear, having a constant pressure to the right. The crowned roads are costing the automobile owners thousands of dollars every year. Many of your readers may not have given the subject much thought, but they must have wondered why the tires gave out first on the right side of the machine.

T. J. BOSSERT.

Hollywood, Cal.

Likes the Slide Valve

Editor THE AUTOMOBILE:

[2,872]—Will you please tell me if there is any patent extant on a working model of a slide valve gasoline motor of the four-cycle type? If there is what objection is there to the adoption of this type of valve?

I am working on a slide valve engine model and to all appearances it is a far superior piece of mechanism to the common poppet valve. I would be very glad to have your opinion on this scheme.

CHAS. F. WHYTE.

Saxonville, Mass.

Types of slide valves have been tried in connection with the gasoline motor, but none as yet has been proven capable of working under the conditions which obtain in automobile practice. The sleeve valve which has gained favor lately is the nearest approach to it which has been put into practical use. There is doubtless a field for very profitable work in connection with this part of the gas engine and the adoption of the slide valve is well within the realms of possibility.

Removing Broken Screws

Editor THE AUTOMOBILE:

[2,873]—The screws which hold the clutch box together on my car are broken off and I cannot remove them by means of a screw driver. The clutch is of the multiple-disc type and the box is held together by means of two narrow flanges which are held by screws which pass through them. Would you kindly tell me how I may remove them and replace them with new ones?

M. F. B.

Cornwall, N. Y.

The remedy which may best be applied to a case of this nature, where the screws are apt to be very small, is to take a breast drill and take the screws out altogether by drilling. This is done in the manner shown in Fig. 3. Small bolts may then be fitted in place of screws or, if it is so desired, the new holes can be tapped and other screws fitted.

The drill employed should be about the same size as the screws, so that more material than is necessary will not be cut away.

Does No Harm

Editor THE AUTOMOBILE:

[2,874]—Please advise in your answers to subscribers if it will do any harm to either

the storage battery or magneto to have both on at one time. My car is fitted with a high-tension magneto, separately connected with one set of plugs and a storage battery connected with another set of plugs.

G. H. SMITH.

Roulette, Pa.

It will do no harm to run both sets of spark plugs at the same time if you so desire.

Points of Wear

Editor THE AUTOMOBILE:

[2,875]—Would you kindly tell me the points that are liable to wear in the cam and follower mechanism?

(2) Is a cam shaft which is oiled by the splash system apt to be given an entirely adequate amount of oil, or should there be some independent means of supplying oil to the bearings of this shaft?

Newark, N. J.

A. R. L.

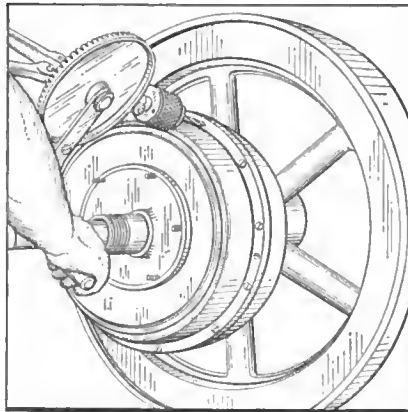

Fig. 3—Method of drilling holes through broken screws in flange

(1) The wear will be found to occur on the cams at the point which first strikes the follower. This point is shown to be just about to be reached in Fig. 4. The roller follower will often wear, as will the push rod bushing, end of the push rod, pivot bushing and the top of the push rod. Wear in the push rod can generally be taken up by special means generally fitted to make these adjustments.

(2) A cam shaft that is lubricated by splash will receive plenty of oil to thoroughly lubricate it.

Idea Arouses Interest

Editor THE AUTOMOBILE:

[2,876]—In your issue of Sept. 7, Robt. W. Hughs, in describing the "eventual" car, mentions a recently patented gear-shifting device. (See page 397.)

May I ask you to describe and illustrate this if of sufficient importance. I feel sure many car owners would be interested.

D. B. GREENE.

Neosho, Wis.

[We suggest that you communicate direct with Mr. Hughs, whose address is Atlanta, Ga.—Ed.]

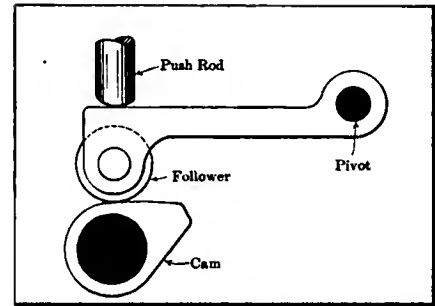

Fig. 4—Showing the wearing points of the valve lifter mechanism

Also Likes Idea

Editor THE AUTOMOBILE:

[2,877]—I should like you to give me further particulars through your columns as to the patent which has been taken out to eliminate the change gear's lever. According to one of the correspondents who described his ideal 1912 car such a patent has been taken out and when it is in general use it will eliminate the need of this part, as the change of gear will be entirely automatic. I have not seen this contrivance referred to except in this article.

F. D. MARTIN.

New York City.

Good Advice

Editor THE AUTOMOBILE:

[2,878]—Several of my friends who drive cars have advised me to release the clutch on rounding a curve, saying that in doing so I will save tire expense. Is this true? If it is, could you tell me the reasons?

CHAS. CAMDEN.

Trenton, N. J.

The advice that your friends have given you is good. In slipping the clutch you will not only decrease the tendency of the car to skid, thus partly eliminating a cause of tire depreciation, but the lateral strains involved when the motor is driving the car when turning a corner will also be dispensed with. There are many little opportunities which are afforded to drivers to lighten their tire and other expenses by the use of a little foresight and care and this is one of them.

Wants Views of Others.

Editor THE AUTOMOBILE:

[2,879]—I have noticed a great deal of discussion lately among those who are interested in automobiling concerning the merits of the use of carbonic acid gas in tires. Many people state that it will leak from the tire at an alarming rate and others assert that this is much exaggerated although true to a slight degree. I would like to know some of your readers' experiences in this matter.

J. E. S.

New York City.

Views of our readers on this subject would no doubt be appreciated by many who are interested in this matter.—Editor.

# My 1912 Automobile

## Some Conceptions of What the Ideal Car Should Be

### A Brooklynite's Ideal

Editor THE AUTOMOBILE:

The ideal car should have a unit power plant. The motor should have four cylinders cast in pairs, having a bore of  $4\frac{3}{4}$  inches and a stroke of  $6\frac{1}{2}$  inches. The valves should be about  $2\frac{3}{4}$  inches in diameter. The motor should be of the T-head type, with the valves enclosed. The valves should have adjustable lifts. There should be a five-bearing crank and cam shaft, the bearings being of bronze with babbitt lining.

The lubrication should be by the automatic splash system, the supply being maintained by a mechanical force-feed lubricator with sight feed on dash.

Ignition should be by Bosch magneto and storage batteries. There should be two sets of spark plugs over valves with an arrangement for cutting off cylinders.

The water should be cooled by a square-tubed honeycomb radiator and a four-bladed fan and circulated by a gear-driven pump.

The clutch should be a multiple disc type running in oil. It should have about sixty plates. There should be a four-speed transmission mounted on ball bearings. Direct speed should be on third.

The car should be shaft-driven with a Timken-Detroit rear axle. Roller bearings should be used with it. The front axle should be of the B. and L. Caster type.

Steering should be by an irreversible worm and sector gear. The steering wheel should be 18 inches in diameter with a corrugated rim.

The frame should be of the best pressed steel. Semi-elliptic springs in front and  $\frac{3}{4}$  in rear. Shock-absorbers should be used.

A 30-gallon gasoline tank should be carried in the rear. The gas should be delivered to a Rayfield carbureter under pressure.

The tires should be guaranteed and should be  $36 \times 4\frac{1}{2}$  inches. Dorian rims should be used. The wheel base should be 124 inches.

There should be four large brakes each 17 inches in diameter and with easy adjustments.

The body should be of torpedo design, seating five people. The driver should be able to get in from right side. There should not be any door on left side in the rear. The seats should be very low and slanted a trifle.

The equipment should include a caravan

top of light color, an automatic windshield built for the car, and the Gray & Davis lighting system. The Warner speedometer should be used, and with the clock built so as to be flush with the dash. Tires should be carried under rear seat and under front seat should be drawers for tools. There should be trunks running the entire length of the running boards. A compressed air self-starter, Klaxon combination horn, tools, foot rails, jack, etc., should also be included in the equipment.

This car should weigh about 3,200 pounds, and should cost about \$3,000.

J. D. CRARY, JR.

Brooklyn, N. Y.

### Illustrates Rotary Sleeve

Editor THE AUTOMOBILE:

While others are telling how they would have their ideal car built, I am going to ask for space in your valuable paper to show how I would build the engine, the all-important part of the car.

Of course it will not have poppet valves, as that would not be the latest fashion, so I have selected the rotary sleeve valve and I trust my ideas will be made plain by the accompanying sketches (Figs. 1 and 2).

The sleeve valve is hollow and has

parts which uncover portholes in the cylinder wall at the proper time to admit the gas and let out the exhaust; the sleeve also has a number of small holes clustered together at the place where it is joined by the intake and exhaust pipes to admit the gas in intake sleeve and to admit the exhaust gases from the exhaust sleeve into exhaust pipe.

The sleeve valves are operated by silent chain and sprocket or gears direct from crank shaft at one-half the speed of crank shaft. They are taper fit within the casings, run on ball and thrust bearings and are adjustable so that a proper fit can always be made, allowing for heat influences and wear.

This sleeve valve is adaptable to any number of cylinders, is easy to cast and machine; the valve parts being made separate and complete. Cylinders are easy to cast and all the parts are right out where you can get at them and put your hands on them. The pistons can go up in cylinders far enough to cover ports when explosion takes place to relieve shock against sleeve valves. The engine is easy to lubricate, easy to repair and will never leak or need grinding. Exhaust can be water-jacketed if necessary. It does away with a great many parts, complication and noise.

H. LEE CLARK.

Canton, Pa.

### What a Canadian Wants

Editor THE AUTOMOBILE:

The car should have a four-cylinder T-head motor with a 5-inch bore and a 6-inch stroke, the cylinders being cast in pairs. The valves should be on opposite side of the motor, be interchangeable, and have a diameter of  $2\frac{3}{4}$  inches and enclosed in dust-proof covers.

The ignition should be furnished from a magneto and storage battery with a double distributor, firing two sets of plugs simultaneously on either battery or magneto.

The carbureter should be of the float-feed automatic type with 2-inch mixing chamber, hot water jacketed, a needle valve adjustment provided so as to be controlled from the dash. The clutch should be of the multiple disc type running in oil bath.

The transmission should be of the selective type giving four speeds forward and one reverse, direct drive being on fourth speed. The engine, clutch and gears should comprise a single unit power plant, and should be suspended from three points in the main frame.

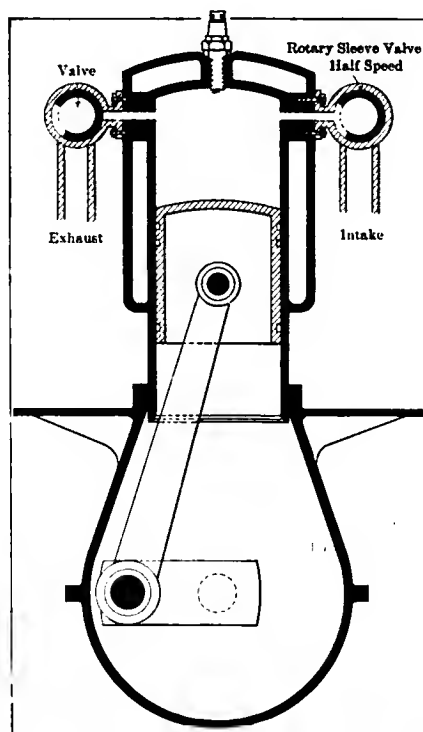

Fig. 1—Section through cylinder with rotary valve

It would be desirable to equip the car with a 124-inch wheelbase. The front springs should be 40 inches long and of the semi-elliptic type, and the rear springs 48 inches long of the three-quarter scroll elliptic type.

Tires of 38 x 4½ inches in size should be supplied, fitted to demountable rims, on both front and rear wheels. I prefer a car with right-hand drive, with the gear-shifting lever on the inside of the fore-door. There should be two pedals, the left to disengage the clutch and operate the service brake, the right to take the place of the emergency brake lever; both brakes should operate on the rear hubs. This arrangement would be more convenient and safer, as there would be no need for reaching for emergency brake lever.

The body of the car should be of aluminum where possible and of the straight-line fore-door five-passenger phaeton type, with low-set seats, having high backs and deep upholstery. This type is very comfortable combined with the long wheel base, large wheels and easy-riding springs.

The engine with large valves, ample size carbureter, and positive ignition system would give the car great power.

The equipment should include mohair top, windshield, two additional demountable rims, self-starter, speedometer.

Such a car as I have outlined should sell for about \$3,500.

RUPERT S. HAMLIN.

Ottawa, Canada.

### Wants Worm Drive

Editor THE AUTOMOBILE:

My ideal automobile is as follows: The wheelbase should be 115 inches, with wheels capable of taking a 36x4-inch tire and with Q. D. rims. The tire pump should be a part of the engine apparatus.

My choice of a motor would be one with rotary or sleeve valves; it would have four cylinders of 4¼-inch bore and 5-inch stroke. The cylinders should be cast in pairs, giving a three-bearing crankshaft. The crankshaft bearings should be of the plain type.

The clutch should be of the multiple-disc type and should be used in connection with a gearset of three speeds: 12, 7 and 4 to 1. The emergency brake should first disengage the clutch and then take up on the drums. The gearset should be located near the clutch and flywheel.

The propeller shaft should be encased in a torque tube and have a worm and gear drive to the rear axle. This would allow the propeller shaft to be aligned with the crankshaft.

The engine base should have hand holes and cover plates for easy examination of the connecting rod bearings, etc. The base should also contain a circulating splash oiling system.

I would specify a magneto for ignition while running and a dry battery set for use

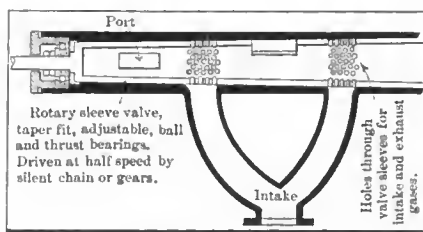

Fig. 2—View of the rotary valve suggested by a reader

in starting. The engine should be self-starting and fitted to the body best suited to the requirements of the owner. This outfit should cost from \$1,200 to \$1,400.

G. P. MCGRAW.

Pierson, Iowa.

### Requires Heavy Engine

Editor THE AUTOMOBILE:

The engine should have four cylinders of the L-type cast in pairs, they should be provided with removable cover plates over the water jackets to allow of cleaning. The motor should have a bore of 5 1-2 inches and a stroke of 7 1-2 inches with 2 3-4 inch valves.

The valves should be enclosed so as to exclude grit. This construction will give a full 48.4 horsepower A. L. A. M. and would doubtless develop 60 horsepower on the brake test.

I would specify an offset crank case split in half with side opposite camshaft removable to allow access to and the removal of the crankshaft, connecting rods or pistons whenever necessary without having to take down the engine.

The lubrication should be by positive force feed, by a gear-driven pump to all bearings and splash to connecting rods and pistons, oil contained in tank at side of engine with sight feed on dash.

Ignition should be by two independent Bosch magnetos, with two sets of Bosch spark plugs over valves.

The cooling system should consist of honeycomb radiator with gear-driven fan and water pump.

Selective type of transmission should be used with four speeds forward and reverse, running on large ball bearings with direct drive on third speed and geared 2 1-2 to 1 on direct.

The large diameter multiple disc clutch should be mounted on ball-bearing running in oil with six tension springs equidistant apart to allow taking up of wear.

Drive should be through shaft fitted with two universal joints, and be packed in grease to differential with a torsion rod alongside, and from differential to rear wheels through live axle. Both differential and live axle ought to run on Timken roller bearings.

The front axle should be of I-beam pressed steel, and a full-floating rear axle ought to be installed.

The exhaust should have two systems consisting of an ordinary muffler, and a

set of pipes with a cut-out coming through the side of the hood.

Wheels should be 38 inches, of wire construction on Timken roller bearings. These should be shod with 5 1-2-inch tires. All wheels should be fitted with quick-demountable rims.

There should be four large brakes (about 17 x 3 inches) on the rear wheels, two internal, and two external.

The wheelbase should be about 135 inches.

Semi-elliptic springs in front and three-quarter elliptic in rear should be used together with shock-absorbers.

Steering should be by worm-and-sector gear, irreversible type with 19-inch wheel on a 2-inch post.

The equipment should consist of full torpedo type body seating two persons. A 40-gallon gas tank should be mounted at rear of seat with a large opening for filling. A top, Warner Autometer Clock and two extra rims with tires should be carried on the car.

A combination Klaxon horn, engine driven tire pump, jack, complete set of tools, and a self-starter should be installed on the car.

The car should be built of the very best material obtainable. The body should be built low with seats on the floor and tilted, and upholstered with smooth leather. Such a car would cost \$4,500 or thereabouts.

A. S. P. O. R. T.

German Valley, N. J.

### Raises New Point

Editor THE AUTOMOBILE:

In my opinion the matter of price in buying a car clashes with the ideal car that the purchaser would specify in the majority of cases, for the simple reason that in buying a cheap or medium-priced car the one who is buying the car generally wishes he could afford to buy a dearer and more refined product.

When stating this opinion I do not mean to say by any means that the cheaper cars are not good; but in making any purchase, whether it be automobile or roller skates, one expects more either in beauty of finish or in mechanical refinements when a higher price is paid than otherwise. The lower and medium-priced cars are far in the majority and it is perfectly natural that it should be so when it is considered that the wealthy class are in the minority and that the majority of automobile owners are people who are in merely what is known as fairly comfortable circumstances.

For the reasons that I have given I cannot agree with INTERESTED in his communication in the issue of October 5, when he states that cheapness is a factor in the ideal car.

LOUIS BOURGEOIS.

New York City.

# Little Bits of Motor Wisdom

## Pertinent Pointers of Interest to Repairman and Driver

**CARE OF TIRES ON THE ROAD—** Care of the tires should not be confined to the time when the car is stationary in the garage before starting on a trip, but should also be a matter which will take the attention of the driver while he is on the road; especially if the trip be one of length. An inspection of the tires is, generally made by the driver before he starts on a trip. This inspection should not be confined merely to the search for cuts, but also for spots which give evidence of an impending blow-out. These are generally determined by a small bubble-like formation on the surface of the casing.

After having searched for cracks and cuts, these bubbles should be made an object in the search, as they are, if anything, more dangerous than are the cuts, for the cuts will allow water to soak through the casing and cause the fabric to rot, which will be a slow process. A bubble will indicate, on the other hand, that the spot at which it occurs is so much weaker than the rest of the tire that it cannot withstand the pressure of the air within the inner tube sufficiently to hold its proper shape. If these weaknesses are discovered within the shop before the car starts upon the trip it would naturally be the duty of the careful driver, who abhors roadside accidents, to restore the casing to its original strength by cutting and vulcanizing. It will often be the case that the driver is not sufficiently acquainted with the process of vulcanizing to attempt the work himself, so that it will naturally have to be handed over to a repair shop, the work of repairing a blister on the casing being a much more complicated undertaking than the repair of a simple cut.

The inspection of the tire in the shop will disclose the weaknesses which have already progressed far enough to evidence themselves, but the others which are not in-

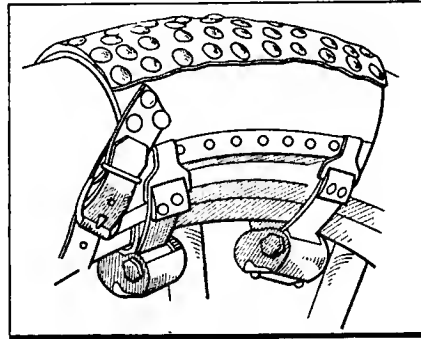

Fig. 1.—Showing a tire boot or gaiter

so advanced a state will remain hidden; it is these cases and the others which are the result of accident which make the occasional roadside inspection a necessity.

Vulcanizing cannot, of course, be well carried on while the car is standing out on some country road, for the simple reason that the necessities are not as a rule at hand, so that other means will have to be found to either restore the tire to its strength temporarily or to eliminate the chances of a blow-out in another way. The spare rim is the medium through which many meet the exigencies of the occasion, while others, who have, perhaps, used their spare rim, employ the tire boots shown in Fig. 1.

These tire boots are very easily attached and will strengthen the shoe sufficiently to hold it against the impending blow-out until a place can be reached where the permanent repair may be made. In attaching the tire boot it should be very firmly strapped to the tire and then also fastened so that it will be impossible for it to slide longitudinally. There are generally straps fitted to the boot for all these purposes, and the only thing remaining for the driver to do is to tighten them sufficiently. If the boots are firmly fitted their usefulness is in-

creased immeasurably and the possibilities of accidents in spite of the boots are greatly decreased.

**MAKING ELECTRIC CONNECTIONS—**It will often be found that a poor connection exists when the ignition of the motor is faulty. In making the new connection it should not be done hurriedly even if this minor repair is taking place somewhere along the road. It is easy to forget that a poor connection was made and the trouble will be sure to evidence itself again in a most uncomfortable manner. If the driver is fortunate enough to have detected the trouble without a long search he should be willing to sacrifice the small amount of time necessary to make the repair as it should be made.

The first three steps are depicted in Fig. 2. A pocket knife is used for the purpose of cutting off the outer insulation for about  $1\frac{1}{4}$  inches along each piece of wire to be connected; the remaining insulation is then burnt off by holding a match beneath the wire. After the insulation has been thoroughly removed the knife is again called into action and the wire scraped so that a good connection will not be hindered by dirty wire. The wire will probably be of several strands, and in this case should be twisted between the thumb and forefinger, in the same manner as a mustache is twirled, so that the various strands will not separate from each other during the time that the connection is being made.

The ends of the wires are then laid together in the manner depicted at C in Fig. 2 and twisted over each other as shown. When they are twisted so that the length of the wires in contact is about an inch, the connections should be soldered as illustrated at E in Fig. 3. The joint is then ready to be bound with tape as shown at F. A careful joint such as this will

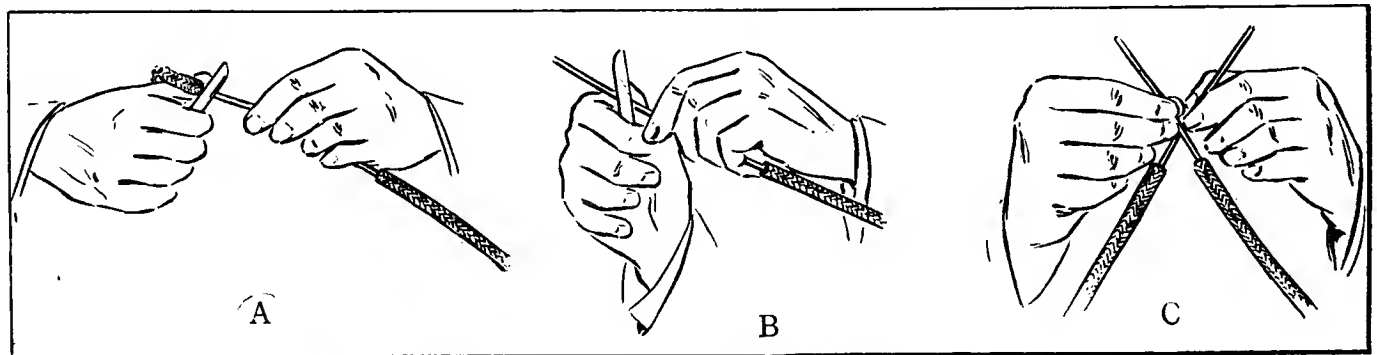

Fig. 2.—Illustrating the first three operations in making a careful electric connection

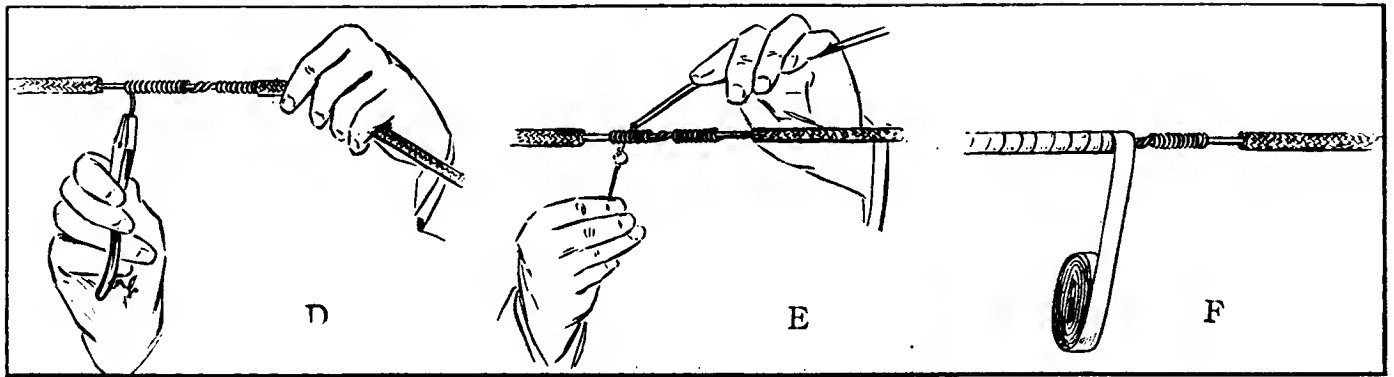

Fig. 3—Depicting the last three operations in making a connection in the wiring

not require much more time than when made carelessly. The difficulties rising from faulty connections are many and are often very hard to detect, especially if they are at the binding posts. The ordinary manner of connecting the wires at the binding posts is merely to form a sort of hook with the end of the wire, place it about the post and then screw the knurled nut down upon it. After a period of vibration the nut will often become loose and since the hook at the end of the wire has nothing left to support it it will leave the binding post and cut off the current. In most cases a casual inspection of the wiring will disclose what has happened, but in other cases the vibrations of the car bring the wire into intermittent contact with the other member of the circuit and the driver is at his wits' end to determine the seat of trouble.

**INSPECT UNIVERSAL JOINTS**—The universal joints are often neglected because they are not located where they are a constant reminder to the proprietor of the car, but it is very necessary, if the car is to be maintained in the best possible condition, that they have an occasional inspection. A good rule in the case of a car which is used moderately is to make this a monthly task. It is not necessary always to thoroughly clean these bearings every month, but they should at least have the supply of oil renewed. If this is done every month and the old oil cleaned out by flushing with kerosene before the new oil is put in they should never give any trouble.

There is generally a plug in the housing which can be removed for the purpose of flushing and refilling. When the plug is removed the motor should be turned over slowly while the kerosene is in the casing so that it will be thoroughly flushed out. Cotton waste should not be permitted within the casing as it will be sure to become caught in some irregularity of the metal and be twined about the bearing after the shaft is in motion.

The grease is generally inserted into the housings by means of a grease gun in the case of the rear universal joint, where graphite grease should be used. The front universal joint casing may be filled with

transmission oil, or, when the weather is cold, cylinder oil may be used to good advantage. In some of the front universal joint casings a level cock is used and when this fitting is employed the oil should be put in up to the level of the cock. When filling, the cock is left open and oil is poured in until there is a flow from this cock, whereupon the cock is shut off and the casing cover replaced and fitted tightly so that the oil which is thrown about by the whirling shafts will not leak from the casing. In most cases the opening for the insertion of grease is merely sealed by a plug.

A very good practice is to lubricate and clean the wheel bearings, differential and gearset at the same time that the two universal joints are attended to, so that the whole work may be done at once with a saving of labor and material.

**EXTRACTING A PIN**—There are numerous clever kinks which suggest themselves to those who are mechanically inclined and remarkable cases of ingenuity are frequently discovered among those who have had but little practical experience in the shop. On the other hand, however, little problems will present themselves which, it would seem, should not present the slightest difficulty to the merest child in the mechanical arts. A riveted pin will sometimes defy the misdirected efforts to remove it for a long time and the idea of using the vise to remove it may not occur to the me-

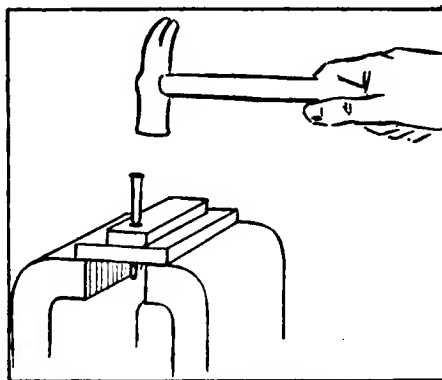

Fig. 4—Method of driving out riveted pin

chanic until he has tried several other ineffectual schemes. The piece may be laid across the jaws of the vise as shown in Fig. 4 and be very easily hammered out by the aid of a punch. In case the end of the pin is riveted over, the end will have to be filed as a rule, although when riveted lightly the burred edge will oppose little resistance to a few light blows of the hammer.

In case the parts to be disassembled are delicate a block of wood should be inserted between each jaw and the metal so that no damage can be given by the edge of the vise. The punch in this case should be carefully laid upon the pin before being hammered so that it will not be liable to slip off and inflict a gash in the part.

**RAPID DEMAGNETIZATION REQUIRED**—The core of the primary winding must be of such material that it permits itself to be readily demagnetized when the current passing through the solenoid is cut off. Soft iron possesses the quality of rapid demagnetization to a marked degree and is for that reason universally employed. The diameter of the coil is generally about 3/4 inch and about this there is a winding of some sort of insulating material which separates it from the primary winding.

It has been discovered that the rapidity of demagnetization will be markedly increased if the core is not made of a solid bar of iron but consists of a bundle of soft iron wires about 6 or 7 inches long. This is the customary method of manufacturing the core of the primary coils for use in automobile work where a rapid action of the trembler is required.

**CALCULATING CLEARANCE IN PER CENT.**—  
Let Volume of clearance = 13.73 cu. in.  
Volume of clearance piston displacement = 44.51.

$$\% \text{ clearance} = \frac{13.73}{13.73 + 44.51} = 23.6$$

This idea will, of course, obtain for any size of motor. All that has to be done is to substitute the right values for those given and then work to the formula.



# My Best Repair

## Broken Studs

ONCE had the misfortune to break a stud that united the manifold to the cylinders. It snapped off close to the cylinder casting, so that it was impossible to file a flat on it or turn it out with a pair of pliers. There was no repairer to whom I could go to have it fixed for several miles around and the noise of the exhaust leaking through was very disconcerting.

I stopped at a village blacksmith and obtained the loan of a drill, which, to say the least, was very primitive. None of the drills that he had would go anywhere near the stud, and I did not wish to spoil the thread, as I had no means of cutting another and did not know the thickness of the water jacket.

Consequently I persuaded him to make me a fine drill out of a piece of steel, which I filed down so as to obtain a cutting edge.

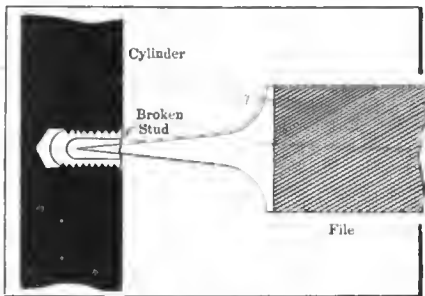

Fig. 1—Method of extracting a broken stud holding the manifold to the cylinders by drilling a hole and using a file

With the aid of the drill I made a small hole in the stud and tapped the tag end of a file in the hole with a hammer, in the manner shown in the illustration, Fig. 1.

Then it was simplicity itself to remove the part. I found it necessary to grind the tag end of the file slightly so as to obtain a good purchase in the hole. Since then I always carry a small drill in my kit and have found it very useful on many occasions. An example of this was given once when I broke a split pin in a shaft over which passed a castellated nut, and after fiddling with pin punches for some time the drill removed the pin in a second.

Montclair, N. J.

R. F. C.

## Cracked Intake Manifold

For some unaccountable reason the aluminum intake manifold of my motor cracked and though the motor did not stop altogether it lost a lot of power and caused me considerable annoyance. I traced every wire in the ignition system, although I was positive the plugs fired properly, took the carburetor to pieces without disturbing the

*Temporary automobile repairs made by the driver or owner while on the road and permanent repairs made in the garage after the run is over, are interesting to all automobile owners.*

*It may be a spring leaf has broken; a shackle bolt or strap may break; a steering tie rod is bent; the car skids into a curb and bends a steering arm or the starting crank; a throttle or magneto connection breaks owing to vibration; a radiator leak is started by a stone or some other means; a leak in the gasoline tank is discovered; there is a small hole in the gasoline feed line; a brake facing may burn out; a brake connection breaks; a front axle gets slightly sprung; a clutch starts slipping, or any one of a thousand things may happen.*

*Every automobile owner is interested in knowing how repairs have been made, how long it took to make them, how much they cost, and by whom they were made.*

*We want you to write in simple language in a letter what repair of this nature you have had to make, how you made it, how long it took you and how much it cost.*

*You can make with your lead pencil one or two rough sketches indicating the broken or damaged part and showing how the repair was made.*

*The experience of each reader is interesting to every other reader. Analyse your past experiences and send in one or two of them.*

*Give your name and address, legibly written. If you do not want your name to appear, make use of a name de plume.*

Editor THE AUTOMOBILE.

manifold and looked at all the valves.

Thinking that the connection of the manifold to the cylinders might be faulty, the gaskets having given out, I took the manifold off and found a decided crack on the side near the motor and consequently out of sight when in the car. Here was my trouble, as by the process of elimination it could be nothing else. I obtained some putty at a hardware store and with the aid of a little insulation tape I bound the fracture around so as to prevent the air from being sucked into the manifold. I cannot describe the difference in the car's running. From sluggish it became vivacious in starting, and would hold on to hills on top speed where before I had been compelled to change.

It is my impression that instead of discarding the manifold as faulty at the factory the makers, or rather some slipshod workman, painted a little shellac over the crack and let it go at that. I took the pipe as soon as I could conveniently spare the car for a few hours and had it welded while I waited. I took the opportunity to have a pair of webs welded on so as to form a support for the carburetor. It is a wonder to me that makers do not support the carburetor by a stay from the base chamber.

J. D. R.

OIL CITY, PA.

## Leather Contacts—Clutch Slips

The troubles that motorists sometimes have on the road are not always the fault of the maker, but are sometimes due to carelessness of his employees. My case was of the latter variety. The clutch on my car is of the leather cone type and I do not want anything better. I took my new purchase over with pride and proceeded to drive it home, which was about 150 miles from New York. Everything went nicely for 70 or 80 miles when I noticed that she was not pulling so well on hills and the engine was slightly inclined to race.

I put it down to a new leather that had not worked in, so I purchased some fuller's earth at a drug store, and sprinkled a little on the leather. Matters improved somewhat for a few miles, but the trouble again manifested itself. I then washed it with some kerosene to expand the leather and

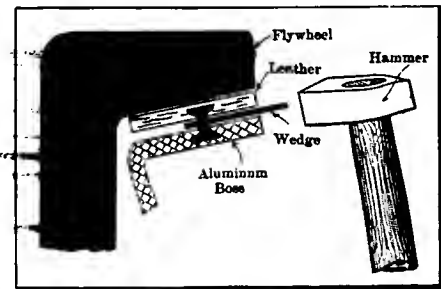

Fig. 3—Forcing a wedge between the aluminum boss and the leather of the clutch to expand the latter, and prevent slipping

afterward with a little gasoline to wash off any dirt that may have been there.

Things had got to that pitch that it was almost impossible to get along at all. I first thought that the floorboards prevented the pedal from coming back far enough, but this was not so.

I then came to the conclusion that it was either a matter of taking the clutch down or faking it to get home. I took the latter idea as being the quickest. I obtained a pair of snips and a piece of tin and cut some short pieces and drove them between the aluminum boss and the leather between the rivets with a hammer in the manner shown in the sketch, Fig. 3. It worked admirably and I got home without any further trouble. I found that the bolts securing the flywheel to the crankshaft boss had been left too long and after the leather had settled, so to speak, these bolts prevented the metal boss of the clutch from sliding in far enough to allow the leather to contact with the flywheel. This I remedied by reversing the bolts, which I found was the correct way for them to be.

KALAMAZOO, MICH.

H. P. M.

## Modern Road Building Enterprises

**F**LINT, MICH., Oct. 14—The county road commissioners of this county have been allowed an appropriation which will amount to about \$43,500 to be spent next year.

**RICHMOND, VA.,** Oct. 14—The Peninsular Automobile Association has raised \$5,000 toward the improvement of the road between Newport News and Richmond, and Richmond has raised \$2,500. A larger sum will no doubt be raised and the work continued.

**BALTIMORE, MD.,** Oct. 16—All objections have been removed and the boulevard between Annapolis and Baltimore will now be constructed as rapidly as the work can be pushed through.

**OKLAHOMA CITY, OKLA.,** Oct. 12—About the last week in November there will be a vote taken on the \$1,250,000 in bonds to construct the first group of hard surface roads in the State. The plans call for 155 miles of asphalt and 21 miles of crushed stone.

**DETROIT, MICH.,** Oct. 14—A good roads meeting will be held in Monroe on October 17, for the purpose of furthering the original route of the Detroit-Toledo highway. There are rumors that it is proposed to make use of highways which have already been constructed in neighboring towns and thus escape Monroe altogether.

**COLUMBUS, O.,** Oct. 14—At the annual meeting of the Ohio Good Roads Federation it was decided to inaugurate a vigorous campaign to secure a constitutional amendment permitting the issue of bonds for the improvement and construction of State roads.

**PHILADELPHIA, PA.,** Oct. 13—At the recent annual meeting of the Quaker City Motor Club, nominations of officers and members of the board of governors were made for the ensuing year. The nominations created a lively interest as the list of nominees outnumbered the list of vacant offices about five to one.

**TOLEDO, O.,** Oct. 14—Splendid progress is being made by the promoters of the new automobile club for owners of machines in Toledo. It is now certain that a full-fledged organization will be in existence in a very short time.

## Adapting the Motor to Farm Uses

(Continued from page 675)

manlike fashion and turning under the stubble and the fertilizers or manure spread on the surface. While the driving wheel tracks in the furrow which the disk is just then forming the right front wheel tracks in the furrow previously made, and this provision, bringing both wheels in the hollow, with the crest between them, prevents the skidding which might otherwise result from the oblique pressure of the disk. The driving wheel has two concentric rims of different widths, so disposed that the wider and smaller rim bears against the untouched soil while the larger and narrower rim follows the bottom of the furrow. On the road only the latter is in action. The small and broad rim is provided with traction ribs which may be either fixed or subject to adjustment.

In the Linard-Hubert motor plough Fig. 4 *a socs percutants* ("with shares that strike") the motor chassis is equipped with a four-cylinder, 20-horsepower motor turning at 400 revolutions per minute, and the plough chassis consists of a simple frame which is mounted at the rear of the motor chassis and from which the plough shares are suspended. By a special mechanism the motor imparts intermittent impulsion into the soil to the shares, actuating them successively, and as the velocity of the impulsions is greatly superior to that of the vehicle's advancement over the soil, the traction of the vehicle is influenced by the work only for brief periods, and the work can go on even if the ground adhesion is imperfect. When the shares are dismounted, the frame of this cultivator plough may be used for many other purposes.—From *Bulletin Official*, August.

**GRAND RAPIDS, WIS.,** Oct. 14—The Grand Rapids Commercial Club has decided to abandon the proposition of bringing the Crowe Motor Car Company, of Detroit, to this city.

**SYRACUSE, N. Y.,** Oct. 14—As the result of a special recruiting campaign the membership of the Automobile Club of Syracuse has increased to 850.

# Calendar of Coming Events

### Shows

- Oct. 7-14.....Chicago, Ill., Show of Chicago Automobile Trade Association.
  - Jan. 2-11.....New York City, Hotel Astor, Importers' Salon.
  - Jan. 6-13.....New York City, Madison Square Garden, Twelfth Annual Show, Pleasure Car Division, Automobile Board of Trade.
  - Jan. 6-20.....New York City, Madison Square Garden, Annual Show, Motor and Accessory Manufacturers.
  - Jan. 10-17.....New York City, Grand Central Palace, Twelfth Annual Show, National Association of Automobile Manufacturers; also Motor and Accessory Manufacturers.
  - Jan. 15-20.....New York City, Madison Square Garden, Twelfth Annual Show, Commercial Division, Automobile Board of Trade.
  - Jan. 22-28.....Providence, R. I., Providence State Armory, Rhode Island Licensed Automobile Dealers' Association, Automobile and Accessories Show.
  - Feb. 17-24.....Minneapolis, Minn., National Guard Armory and Coliseum, Annual Automobile Show, Minneapolis Automobile Show Association.
  - Jan. 27-Feb. 10....Chicago Coliseum, Eleventh Annual Automobile Show under the auspices of the National Association of Automobile Manufacturers. Pleasure cars, first week. Commercial vehicles, second week.
  - Feb. 14-17.....Grand Rapids, Mich., Third Annual Show.
  - Feb. 19-24.....Hartford, Conn., Annual Show, Automobile Club of Hartford, State Armory.
  - Week Feb. 22.....Cincinnati, O., Annual Show, Cincinnati Automobile Dealers' Association.
  - March 2-9.....Boston, Mass., Tenth Annual Show, Boston Automobile Dealers' Association, Inc.
- Meetings, Etc.**
- Nov. 20-24.....Richmond, Va., First American Road Congress, under auspices of American Association for Highway Improvement.
  - Nov. 22.....Road Users' Day, under direction of Touring Club of America.

- Jan. 18-20.....New York City, Annual Meeting of the Society of Automobile Engineers.
  - Race Meets, Hill-Climbs, Etc.
  - Oct. 9-13.....Denver, Colo., Reliability Run, Denver Motor Club.
  - Oct. 11-18.....San Francisco, Cal., Reliability Run, Good Roads Assn. of Northern California.
  - Oct. 13-14.....Peoria, Ill., Track Races, Peoria National Implement and Vehicle Show.
  - Oct. 14.....Santa Monica, Cal., Road Races.
  - Oct. 14 (to 26)....New York City, Start of the Annual Glidden Tour, en route for Jacksonville, Fla.
  - Oct. 30.....Minneapolis, Minn., Hill Climb.
  - Oct. 20-21.....Sioux City, Iowa, Track Races, Sioux City Automobile Club.
  - Oct. 21.....Atlanta, Ga., Track Races.
  - Oct. 21.....White Plains, N. Y., Track Races, Westchester Driving Club.
  - Oct. 21-22.....Los Angeles, Cal., Track Races, Motordrome.
  - Oct. 27-Nov. 3....Chicago, Ill., Thousand-Mile Reliability Run, Chicago Motor Club.
  - Oct. 28.....Newark, N. J., Reliability Run, Newark Motor Club.
  - Oct. 30.....Harrisburg, Pa., Economy Run, Motor Club of Harrisburg.
  - Oct. 31.....Shreveport, La., Track Races, Shreveport Automobile Club.
  - Nov. 2-4.....Philadelphia Reliability Run, Quaker City Motor Club.
  - Nov. 3-4.....Columbia, S. C., Track Races, Automobile Club of Columbia.
  - Nov. 4-6.....Los Angeles-Phoenix Road Race, Maricopa Auto Club.
  - Nov. 9.....Phoenix, Ariz., Track Races, Maricopa Automobile Club.
  - Nov. 9, 10, 12....San Antonio, Tex., Track Races, San Antonio Auto Club.
  - Nov. 27.....Savannah, Ga., Vanderbilt Cup Race, Savannah Automobile Club.
  - Nov. 30.....Los Angeles, Cal., Track Races, Motordrome.
  - Nov. 30.....Savannah, Ga., Grand Prize Race, Savannah Automobile Club.
  - Dec. 25-26.....Los Angeles, Cal., Track Races, Motordrome.
  - Nov. 3-11.....London, Eng., Olympia Show.
- Foreign Fixtures**
- Oct. 12-22.....Berlin, International Automobile Exhibition.

# THE AUTOMOBILE

Vol. XXV

Thursday, October 19, 1911

No. 16

## THE CLASS JOURNAL COMPANY

H. M. SWETLAND, President

CONDE NAST, Vice-President and General Manager

E. M. COREY, Secretary and Treasurer

231-241 West 39th Street, New York City

Cable Address - - - - - Autoland, New York  
Long Distance Telephone - - - - - 2046 Bryant, New York

### SUBSCRIPTION RATES

United States and Mexico - - - - - One Year, \$3.00  
 Other Countries in Postal Union, including Canada - - - - - One Year, 5.00  
 To Subscribers—Do not send money by ordinary mail. Remit by Draft,  
 Post-Office or Express Money Order, or Register your letter.

Entered at New York, N. Y., as second-class matter.

The Automobile is a consolidation of The Automobile (monthly) and the Motor  
 Review (weekly), May, 1902, Dealer and Repairman (monthly), October, 1903,  
 and the Automobile Magazine (monthly), July, 1907.

## Baggage Must Be Carried

WHAT would you think of a well-dressed young man living at one of the leading hotels in New York starting out on a Monday morning for the laundry with both coat pockets filled with collars, his pajamas under one arm, his soiled linen under the other arm, his hose in one hand and old handkerchiefs in the other hand? Such a sight would be an absurdity, yet many of our automobile tourists do this identical thing when it comes to going away in their cars for a tour of several days or perhaps a few weeks. The baggage is the bugbear with them; they tie part of it onto the back of the tonneau; they load all that they can into the tonneau until it is so full that the passengers have not room on the floor for their feet; they pile as much as they can onto the running board at the right side and on the left side; they put suitcases between the front fender and the hood on the right side and also on the left side; they put extra oil cans on the floor boards of the front seat; they tie suitcases onto the sides of the tonneau over the fenders; they put some of their surplus clothing under the rear seat cushion and some more of it on the coat rail at the back of the front seat; and with all this done they fill their overcoat pockets, stuff every little pocket in the car doors and fill every spare corner in the car.

It is not very pleasant making a tour in such a car. It might be all right for a short day, with the sun shining and the dust not too bad, but it would be most uncomfortable in a rain storm or on a cold day. The starting off of the Glidden tour was an object lesson in lack of preparedness in carrying baggage on a long tour. On other pages are illustrated the various means of transmuting a pleasure car into something little worse than a truck and little better than a gypsy van.

It was not always the fault of the tourist; part was his and part was also that of the maker of the car body. Car bodies are not well designed for carrying baggage on a tour. There is not enough room to carry baggage commensurate with the number of people traveling in the car. The car body is built to carry people but not

to carry their baggage. This is not right. The body must be improved so that it will carry the baggage. What is the use of having a car to travel for weeks at a time but yet not be able to take the necessary baggage. To travel for one or more days or for one or more weeks a goodly amount of baggage must be taken along, and the car builder who fits a body which is entirely inadequate to care for such conditions is not meeting face to face one of the big problems of the car industry to-day.

The baggage-carrying factor must be wrestled with. It must be settled. It cannot be settled by the method described in the opening paragraph of this editorial. How absurd it is to spend hundreds of dollars imparting the finest possible finish to an automobile body and then hang baggage over every attainable part of the car. This is preposterous. A car should have adequate baggage-carrying possibilities and it is not impossible to make a body that has such. One solution is impressing the body designer of the fact that a car body is intended to carry a reasonable amount of baggage as well as a reasonable number of people.

One solution of the baggage-carrying scheme is to use such baggage accessories as are on the market, consisting, as they do, of trunks for the rear of the tonneau or neat cases for the running boards. No matter where the trunk is it should be of neat design and good finish. It is poor judgment to place a 5-cent trunk on a \$100 car. The scheme of harmony should be carried out. Another solution is to study space economy in body design. The gasoline tank, in the majority of cars, occupies the entire space under the front seat. If pressure feed were used the tank can be placed under the chassis at the rear. One maker is placing the fuel tank under the center of the chassis at the right side where it is entirely concealed and where it is convenient for refilling. If the space under the front seat were left free it could be used for a score of things. The tools, which are usually carried under the rear seat, can be placed under the front one. These tools should be under the front seat, because, then, they can be obtained and put away again without disturbing everyone in the tonneau.

When the tools are located under the front seat the space beneath the rear seat should be utilized for carrying spare tires and suit cases. It seems folly to suggest carrying all here, but some foreign makers have solved this problem and are able to get two suitcases under the seat and carry two spare tires back of the tonneau. One maker has become still more economical and has designed his top to fold over this compartment. There is plenty of room in the rear of the tonneau for suitcases, tires and other small packages, but you cannot get them into such a space unless the body design is carried out accordingly. It is a question of designing and not an after-thought. When the tailor makes your overcoat he puts in the pockets. They are not added as needed after the coat has been worn half a season. The fact that you do not fill each pocket each time you put the coat on is not any reason why you should not have the pockets. The pockets are useful, they serve their purpose, and when needed they are needed.

So with an automobile, the baggage spaces are needed. You may not make any use of them in trips around town, but the first time you go away to spend a day

or so they are very much in demand. Then there is a rallying to the hardware store for rope or leather straps to decorate the outside of the car with traveling necessities. The 1912 body maker should meet this question face to face. If he cannot entirely solve it he should solve as much of it as he can. If you cannot have the whole, then furnish a part, at least. This work cannot be accomplished at once, it will take a few seasons, perhaps more.

In carrying baggage several points of value should be considered. A suitcase should be protected. As it is at present if the suitcase is carried outside of the body the dust finds its way into the interior, to the damage of all the clothing. If wet weather is encountered there is much damage due to dampness. As it is at present when you go on a tour of several days you run a chance of ruining the car finish with the suitcase or spoiling the suitcase. Neither of these is economical. It should be possible to use a suitcase a few days on a car without injury. Extra tires have always been

an eyesore on highly finished cars and should be removed from the side of the car. If the tires have to be carried on the side they should be encased in good covers and not left without any covering at all with the paper wrapping that was on when taken out of the tire depot.

The external appearance of the car has a moral effect on all who see it. When a car starts out loaded for a tour it should tend to excite the desire for touring in the minds of those who cannot go. A well-trimmed car, which looks a tourist in every respect, will do this; but a car with baggage scattered all over it will not attract but actually repel. It will help touring when cars are fitted with bodies built to carry baggage for tours. The very fact that care has been taken to provide such spaces impresses the car owner with the fact that the car is intended for touring. As it is to-day the owner simply thinks of his car as an around-town vehicle and not a cross-country one. The car owners can assist in this work by taking it up with the makers.

## Shows Engross Attention

NEW YORK CITY, Oct. 17—Applications for exhibition space at the coming show of the N. A. A. M. at the New Grand Central Palace continue to be received. The show will be held January 10-17 and will no doubt be a great success, as the space remaining is rapidly being decreased. Among the latest applicants are the Decatur Motor Truck Company, Universal Motor Truck Company, Atterbury Motor Car Company, Velie Motor Car Company, Koehler Company, Bergdoll Company, Metz Motor Car Company, Westcott Motor Car Company, King Motor Company, Bushnell Press Company and the Atlantic Motor Truck Company.

## Chicago Show Successful

CHICAGO, Oct. 16—The Fall show of the Chicago Automobile Trade Association, which came to an end Saturday night, was a success far greater than anticipated by its promoters at the beginning of the week. Favored by Indian Summer on all but the last day, the turnout of the prospects was surprising and as a result many of the dealers down the row actually made sales that were not anticipated. The country dealers, too, took a great interest in the affair and some of the large branches like Ford, Buick, Studebaker, Hupmobile and Overland had their agents come in and look over the 1912 models.

There only was one feature that slipped a cog. That was the trackless trolley, made up of demonstrating cars which were supposed to carry spectators up and down the row. The idea was all right in theory but apparently did not work out well, the people being puzzled as to how to get tickets. Joy riders took advantage of the opportunity to a certain extent and toward the latter end of the week some of the dealers pulled their cars out of the line and controlled them themselves. However, the fundamental idea seems all right and doubtless another year the details can be worked out better and the trackless trolley made really useful.

Outside of the Chicago fire celebration on Monday, the feature of the week was the truck parade which was held Friday night. The parade was organized at a day's notice but despite this there were more than 200 vehicles in line, the majority of which were furnished by the big mercantile houses of Chicago, which took a great interest in the turnout. The show was put on with the object of stimulating trade at this particular season, and, judging from the numbers who attended the salesrooms during the week, it was a big success.

## New Sanctions Granted

NEW YORK CITY, Oct. 17—A telegraphic application for a sanction covering a tour from Denver to New York has been received by the contest board of the A. A. A. It will probably be granted at an early date according to advices here. The matter has been turned over to Ralph W. Smith, of Denver, Colo., who is one of the twelve members of the contest board, and will be decided by him.

Part of the route between these two cities was covered in the Glidden tour of 1909 and there is no reason why the tour should not prove a success since conditions are very good for intermediary points. The date of the tour is from October 26 to November 7. The tour will be held by the Denver Chamber of Commerce.

Sanction has been granted for a series of races to be held over the Los Angeles motordrome on October 21 and 22. There are a number of cars which entered in the Santa Monica race which will participate in the events. The race is held under the auspices of the Los Angeles Motor Dealers' Association.

## Kansas City at Peace

KANSAS CITY, Mo., Oct. 16—Special telegram—Kansas City automobile dealers have at last consolidated. After 2 years of wrangling, dealers of both organizations met here to-night and formed a new association which they named the Kansas City Motor Car Dealers' Association. This is the culmination of the bitterest fight ever known in the motor world. Two shows a year have been held and thousands of dollars have been spent by the dealers of each association to outdo the other; many attempts have been made to consolidate both associations but up until to-night they have met with defeat. By unanimous vote one big automobile show was decided upon, the date being set immediately after the Chicago show.

The following officers were elected: J. Frank Witwer, of the Witwer Motor Car Company, president; W. E. Mallory, of the Jackson Motor Company, vice-president; R. C. Greenlease, of the Greenlease Motor Car Company, secretary; and H. G. Kirkland, of the Overland Company, treasurer. The show committee follows: T. S. Dey, Geo. A. Bond, C. B. Riggs, S. F. Scott and E. S. Hunnewell.

This amicable solution of the situation is a most desirable one as the different dealers and branches, as well as the industry, have suffered because of the unnecessary rivalry during the last couple of years.

# Saurer-Mack Combine Completed

NEW YORK, Oct. 18—The uniting of the Mack and Saurer truck interests, which was announced in these pages some weeks ago, has been perfected, the new organization, an incorporation of Delaware, being known as the International Motor Company, with a capital of \$10,000,000. This new incorporation will have its head offices at 30 Church street, New York City, and will have the entire management and supervision of The Mack Bros. Motor Car Company, Allentown, Pa., and the Saurer Motor Truck Company, Plainfield, N. J. The manufacture of Mack and Saurer trucks will be carried on at these respective plants, the factories being conducted as distinct organizations. It is expected that the output for the coming year will be approximately 2,000 trucks of different types and load capacities. The present sales branches of both Mack and Saurer will become the branches and agencies of the International Motor Company, which organization will conduct in all of the principal cities service stations for both makes of trucks. These stations will include inspection and maintenance systems.

Officers and directors of the International Motor Company are: President, C. B. Coleman; Chairman of the Board, W. D. Sargent; Vice-President, J. M. Mack; Treasurer, S. C. Richardson; Secretary, Vernon Monroe. Directors are: Otis H. Cutler, President American Car & Foundry Co.; Benjamin Story, Jr., Vice-President of the Bankers Trust Co.; Arthur H. Lockett, Pomroy Bros., bankers; Hunter Marston, Blair & Co., bankers; Charles H. Sabin, Vice-President Guarantee Trust Co.; George B. Case, of White & Case, attorneys; William G. Pearce, Vice-President American Brake Shoe & Foundry Co.; C. P. Coleman, President Saurer Motor Truck Co.; W. D. Sargent, President Reading Steel Castings Co.; Herbert H. Dean, Edward B. Smith & Co., bankers; John M. Mack, President Mack Bros. Motor Car Co.; Joseph S. Mack, Treasurer Mack Bros. Motor Car Co.; Montgomery Hare, attorney; Warren A. Wilbur, President E. B. Wilbur Trust Co.; Harry W. Davis, Secretary Delaware Trust Co.; Martin E. Kern, Vice-President Mack Bros. Motor Car Co. The general offices of the International Motor Car Company will be at 30 Church street, New York City.

## Denver Electric Parade and Reliability

DENVER, COL., Oct. 14—The opening feature of the Second Annual Electric Show of the Colorado Electric Club, which opened here this evening, was a big parade of electric vehicles exclusively. Never before in America has there been such a parade and the enthusiasm it created augurs well for its adoption by electric clubs in many other sections of this country. It was an electric parade in every sense of the word, even the policemen, who cleared the way, rode in electric runabouts and the bands appeared in huge electric band wagons. Many of Denver's most prominent people entered their cars, many of which were beautifully decorated.

Handsome prizes were awarded to the first eight cars in the coupé and open runabout classes. Mrs. Charles A. Murnan's coupé, which was covered with a profusion of imitation mountain columbines, the heart of each one being a tiny incandescent light, won first place in its class. Mrs. W. P. Carstarphen, Jr., wife of W. P. Carstarphen, president of the Colorado Electric Club, presented the best open runabout. The body of the car was draped in white and poised in front of the driver was a large star outlined with electric lights.

DENVER, COLO., Oct. 17—Special Telegram—The winner of the 880-mile Denver reliability tour held here last week is still in doubt. A protest has been filed against the decision of the ref-

eree in awarding first place to the Flanders roadster, which was announced to-day as winner, with only 17 points against it. The Ford was awarded second, 19 points; and Cadillac, third, 23 points. The Ford protested the decision on the ground that the technical committee did not inspect the Flanders properly. The decision of the judges was delayed because of the thorough mechanical tests given the cars after finishing the tour and the final result now is delayed indefinitely because of the absence of the referee from the city. The twelve cars left Denver Monday, October 9, and returned Friday after covering 880 miles of prairie and mountain country in Colorado and Wyoming. The route covered fine selling districts and the excellent showing of the cars under the severe conditions means a great impetus to rural trade. The tourists were welcomed enthusiastically at all points, the run was a success in every way.

Car	Driver	Penalty
Flanders	L. M. Slater	17
Ford	William Thorney	19
Cadillac	Bert Hall	23
Ford	Fred Alkire	35
Regal	J. E. Barker	54
Everett	M. B. Fletcher	59
Flanders	Leroy Ward	74
Mitchell	A. J. Wilson	84
Reo	Jas. McDonald	103
Elmore	Geo. Williams	104
Maxwell	Geo. McIntosh	104
Buick	R. E. Young	Withdrawn

## Wagner to Drive a Fiat

Louis Wagner, one-timer winner of the Vanderbilt cup and winner of the first American grand prize race, has been selected by the Fiat Company to drive a Fiat in the coming grand prize race in place of Felice Nazzaro, originally selected.

## National Wins Santa Monica

(Continued from page 661)

The cylinder sizes of the different cars in the four different races are as follows, the order of cars being the same as in the tabulations given on pages 660 and 661. All cars were four-cylinder types:

Car	Driver	Bore (inches)	Stroke (inches)
National	Herrick	5	5 11-16
Marmon	Patschke	4 3-4	7
Marmon	Dawson	4 3-4	7
National	Merz	5	5 11-16
Pope	Dingley	4 3-4	5 1-2
Stutz	Lewis	4 3-4	5 1-2
Marmon	Keen	4 23-64	5
Marmon	J. Nikrent	4 23-64	5
Merced	Hanshue	4 3-4	5
Buick	L. Nikrent	3 3-4	3 3-4
Ford	Charles	3 3-4	4
E-M-F	Seibel	4	4 1-2

The official times for the nine contestants in the small race for cars with motors under 23 cubic inches were received too late to appear in the general tabulation. This race had four contestants that finished, a Buick, a Ford, an E-M-F and a Flanders. The Buick, driven by Nikrent, traveled the 101 miles at an average speed of 59.20 miles per hour; the Ford at 57.21 miles per hour, and the E-M-F at 52.30 miles per hour. The total running time of the Buick was 103 minutes and 21.70 seconds; the Ford's time was 105 minutes 22.45 seconds, and the E-M-F time 115 minutes and 54.20 seconds. Soules, driving a Flanders, completed the race, but his time is not known; Hanshue, in a Reo, made 10 laps; Fleming, in a Locomobile, ran 10 laps; Dequelin, in a Sunset, made 8 laps; Anthony, in a Regal, traveled 5 laps, and Smith, in a Maxwell, 2 laps.



# World's Records Broken at Peoria

PEORIA, ILL., Oct. 14—In concluding the two-day race at the Peoria track, held as one of the attractions at the National Implement and Vehicle Show, the Marmon Wasp and Hotchkiss Whirlwind lowered the Illinois State record for 5 miles on a 1-mile circular track very substantially. The former record, made on the Hawthorne track at Chicago, was 4:70 for the 5 miles. Heineman, driving the Wasp, made the five laps in 4:33 and Judy Kilpatrick, driving the Hotchkiss, lowered the Wasp's time by 1 second.

The only accident of the two-day meet came in the last lap of the last race on the final day of the meeting. The big Hotchkiss car, driven by Kilpatrick, was driven into the fence on the 1-4-mile turn by Raimey in his Cino. Neither driver nor car was badly injured.

On the first day of the meet, October 13, John Raimey, driving

the Cino racer, set two world's records for a 1-mile, flat, circular track in the 10-mile, class E, non-stock race for cars of 300 cubic inches piston displacement and under, the feature of the opening day's motor race card at the National Vehicle and Implement Show here this afternoon. With a standing start he made the first lap in 1:03, a new world's record for cars of that size. He pulled down another world's mark when he completed the 10 miles in 9:56 2-5. He finished a winner by 3 seconds over a field of eight fast cars. Raimey also won a 5-mile, class C event, for cars of 231-300 cubic inches piston displacement.

In the time trials Judy Kilpatrick in his 200-horsepower Hotchkiss nosed out Heineman in the Marmon Wasp, negotiating the mile in :55 2-5. The Wasp was a second slower. Cino car finished third in :56 flat.

The summaries for both days are as follows:

### SUMMARIES OCTOBER 14

Time Trials, 1 Mile		
Car	Driver	Time
Hotchkiss	Kilpatrick	0:55 2-5
Marmon Wasp	Heineman	0:55 3-5
Cino	Raimey	0:56
Staver-Chicago	Monckmeier	1:00 1-5
Interstate	Fouts	1:01 2-5
Little Case Giant	Heineman	1:02

5-Mile, Class C, 231 to 300 Cubic Inches		
Car	Driver	Time
Cino	Raimey	4:59 4-5
Staver-Chicago	Monckmeier	5:03 3-5
Little Case Giant	Heineman	5:03 4-5
Staver-Chicago	Knudson	5:08

2-Mile, Novelty, Australian Pursuit, Stock Cars		
Car	Driver	Time
Staver-Chicago	Monckmeier	5:08 1-5
Case "6"	Jaggersberger	5:16

10-Mile, Class E, 300 Cubic Inches and Under		
Car	Driver	Time
Cino	Raimey	9:56 2-5
Abbott-Detroit	Roberts	9:59
Staver-Chicago	Monckmeier	10:00 1-5
Staver-Chicago	Knudson	10:35

3-Mile, Class E, Handicap		
Car	Driver	Time
Marmon Wasp	Heineman	3:04
Little Case Giant	Maxwell	3:20 2-5

10-Mile, Class C, 301 to 450 Cubic Inches		
Car	Driver	Time
Velic	Stickney	10:38 1-5
Interstate	Fouts	11:24

### SUMMARIES OCTOBER 14

Time Trial, 1 Mile		
Car	Driver	Time
Marmon Wasp	Heineman	0:54 4-5
Cino	Raimey	0:56 3-5
Hotchkiss	Kilpatrick	0:57 1-5
Abbott-Detroit	Roberts	0:57 3-5
Velic	Stickney	1:00 3-5
Interstate	Walker	1:02 1-5
Little Case Giant	Heineman	1:02 4-5

### Bulck Match Race, 3 Miles

Bulck	Ross	3:41
Bulck	Wonderlick	out
Class C, Non-Stock, 231 to 300 Cubic Inches, 5 Miles		
Cino	Raimey	5:14
Staver-Chicago	Monckmeier	5:20 1-5
Little Case Giant	Heineman	5:23 1-5
Staver-Chicago	Knudson	5:48

### Class E, 3-Mile Handicap

Little Case Giant	Maxwell	2:59 3-5
Marmon Wasp	Heineman	3:00 4-5
Class C, Non-Stock, 301 to 450 Cubic Inches, 5 Miles		
Interstate	Walker	5:16 2-5
Interstate	Fouts	5:22
Velic	Stickney	5:25 1-5
Bulck	Wonderlick	5:27 1-5

### High-Gear Slow Race, 1/8 Mile

Interstate	Fouts	1:01 4-5
Class E, Non-Stock, Under 450 Cubic Inches, 10 Miles		
Staver-Chicago	Monckmeier	10:05
Interstate	Walker	10:16 2-5
Velic	Stickney	10:25
Little Case Giant	Heineman	10:35 3-5
Bulck	Ross	10:45 1-5
Staver-Chicago	Raimey	10:52 4-5
	Knudson	5:49

### Class D, 5-Mile Free Handicap

Little Case Giant	Raimey	5:40 1-5
Staver-Chicago	Heineman	5:45 1-5
Velic	Stickney	5:52 2-5
Staver-Chicago	Monckmeier	5:55 2-5
Interstate	Walker	5:00 3-5

### Special Race Against Track Record, 5 Miles

Marmon Wasp	Heineman	4:33
Hotchkiss	Kilpatrick	4:32

## Minneapolis to Hold Hill Climb

MINNEAPOLIS, MINN., Oct. 15—Another change has been made in the date for the coming hill-climb and the sanction which was applied for last week affixes the time for Thursday, October 26, at 1:30 p.m. Arrangements have been completed and permission has been secured to hold the contest on the Columbia Heights hill leading off Central avenue. The hill is three miles long.

S. L. Stone, for the past three years assistant to J. B. Eccleston, sales manager of the Oakland Motor Car Company, Pontiac, Mich., has been transferred to Buffalo, where he becomes general manager of the Centaur Motor Company, of that city, dealers of Oakland cars in western New York and Pennsylvania.

The Newton-Humphreyville Company, Newark, N. J., were appointed Thomas dealers by Manager C. S. Henshaw, of the New York branch, the past week, and will handle that car in central New Jersey.

## S.A.E. Visit is Gaining

NEW YORK, Oct. 18—Foreign manufacturers are manifesting an active interest in the intending visit of members of the Society of Automobile Engineers to Europe. Many of them have expressed a willingness to open their establishments to the inspection of the party which leaves New York November 1. The latest invitation is from the famous house of Lemoine, in Paris, which is perhaps the leading manufacturer of motor vehicle axles and forgings in Europe. The proprietors have asked the officials of the S. A. E. to include a visit to the plant and an inspection of the various processes of axle construction in the program during the stay of the members in Paris.

While in London the S. A. E. party will inspect the workings of one of the largest garages handling public service vehicles. This is of unusual present interest on account of the financial success of the great London motor bus and motor cab services which is attributable to efficient methods of garage management.

## Detroit Building Operations Brisk

**D**ETROIT, MICH., Oct. 16—As further evidence of the prosperous condition of the automobile industry, the Hudson company has broken ground for a large addition to its extensive plant on Jefferson avenue completed only a year ago; and two other companies, the Hupp Corporation and the Hupp Motor Car Co., will begin the erection of new factory buildings in the immediate future.

The Hudson addition will connect with the east end of the present plant. It will be 530 feet long, 60 feet wide and two stories high, and will conform, in type of construction and in its external appearance, to the rest of the establishment. Steel and concrete are to be used almost exclusively in the construction. The extension will give the company 63,600 additional square feet of floor space. It is to be ready for occupancy by January 1.

The Hupp Corporation has awarded the contracts for its new factory building and power house at Lycaste street and the Michigan Central Railroad and work is to be rushed to have the structure finished in the minimum of time.

As a site for a complete new plant, the Hupp Motor Car Company has acquired 7 acres of land at Mount Elliott and Milwaukee avenues, adjacent to the new Belt Line Railway and opposite the plant of the Grabowsky Power Wagon Company. The purchase price is said to have been about \$40,000. Plans are being prepared for a plant that will triple the capacity of the company's present factory, at Jefferson and Concord avenues. These quarters were outgrown several months ago and it was found necessary to lease other buildings.

Work is progressing so rapidly on the new Ford buildings, which will double the present capacity of the big plant, that they will be finished by December 1, fully a month earlier than time called for in the contracts, according to the present outlook. In this connection, it transpires that the John R. Kime mills, of Buffalo, which do most of the pressed steel work for the Ford company, and which are controlled by the latter, will be moved here when the extensions are completed. This information comes direct from Henry Ford, president of the company. "We are also putting in a new 5,000 horsepower gas engine to replace the 1,600 horsepower engine we are now using," said Mr. Ford to the representative of THE AUTOMOBILE. "We intend to produce our own gas for this engine."

Local car makers are greatly interested in the outcome of plans now under way for the establishment of a mammoth steel plant on a 50-acre site west of the city, on the River Rouge. The interests behind M. A. Hanna & Co., of Cleveland, are backing the project. The same interests control the Detroit Iron & Steel Co., which has a large plant on Zug island, in the Detroit river, for the production of steel in the raw state. The new plant, if the plans go through, will be operated in conjunction with the Zug island enterprise, taking over the raw steel and turning it out a finished product for all manufacturing purposes. The concern will be known as the Michigan Steel Co. and will be capitalized at \$2,500,000. The Union Trust Co., of this city, and Peabody, Houghteling & Co., of Chicago, have agreed to underwrite the bonds that are to be issued. The establishment of a steel plant here would mean a great deal to the automobile industry of the town in the way of quicker deliveries. It would also mean a big saving in freight rates.

The organization of the new export bureau of the Detroit Board of Commerce was perfected at a largely-attended meeting of representative manufacturers, last week, and the bureau is planning a vigorous campaign for the extension of Detroit's export trade. The work will be in the hands of the same committee that had charge of the preliminary details, F. E. Fisher.

of the Studebaker Corporation, representing the motor car interests, as previously announced.

A recommendation by the special tax commission appointed by Governor Osborn to investigate the question of taxation, that corporations be taxed on their intangible values, has caused some alarm among the car manufacturers, who are already making ready to oppose this plan when the commission's report is taken up for discussion in a series of public hearings at Lansing, in the near future. The car makers declare that the proposed plan is confiscatory.

### Accessory Organization Grows

NEW YORK, N. Y., Oct. 14.—At a recent meeting of the Motor and Accessory Manufacturers held at headquarters in this city, twenty-five new members were enrolled, representing different interests in the automobile accessory field. This brings the total membership up to 247.

The following are the applications received into membership: Automobile Supply Manufacturing Company, 220 Taaffe Place, Brooklyn, N. Y.

The Batavia Rubber Company, Batavia, N. Y.

Bower Roller Bearing Company, Detroit, Mich.

The Buda Company, Harvey, Ill.

Carnegie Steel Company, Carnegie Building, Pittsburg, Pa.

Detroit Electric Appliance Company, 264 Jefferson avenue, E., Detroit, Mich.

Doehler Die Casting Company, 187 West 9th street, Brooklyn, N. Y.

The Eagle Company, 98 Warren street, Newark, N. J.

The Esterline Company, Lafayette, Ind.

Falls Machine Company, Sheboygan Falls, Wis.

Federal Rubber Mfg. Company, Cudahy, Wis.

The Hess Spring & Axle Company, Carthage, O.

International Acheson Graphite Company, Niagara Falls, N. Y.

Jacobson-Brandow Company, 122 Columbus avenue, Pittsfield, Mass.

The G. Piel Company, 13th street and Boulevard, Long Island City, N. Y.

The Simms Magneto Co., 1780 Broadway, New York City.

The Start-Lite Company, 1502 Michigan avenue, Chicago, Ill.

Stutz Auto Parts Company, 221 West 10th street, Indianapolis, Ind.

The United Rim Company, Second National Bldg., Akron, O.

Universal Tire Protector Company, Angola, Ind.

Universal Wind Shield Company, 1607-9-11 Prairie avenue, Chicago, Ill.

Voorhees Rubber Mfg. Company, 18 Bostwick avenue, Jersey City, N. J.

Waukesha Motor Company, St. Paul avenue, Waukesha, Wis.

Widmer Machine Works, 144th street and S. Boulevard, New York City.

Wolverine Lubricants Company, 80 Broad street, New York City.

### Wilson Heads American Manufacturing

NEW ALBANY, IND., Oct. 16.—George H. Wilson has been elected to the presidency of the American Automobile Manufacturing Company, of New Albany, Ind. He succeeds Berton B. Bales, who retired several weeks ago. This concern has decided to broaden the scope of its products and in the future will manufacture a complete line of pleasure cars, consisting of runabouts, roadsters, touring cars, coupés and limousines.

# Introduction of Power Wagons

By HAYDEN EAMES

It seems to be a habit of the practical mind to try to stretch its own specialty to the solution of every problem it encounters, whether obviously fitted for it or not. For many years this tendency, directly or indirectly, delayed the work of introduction of power wagons more perhaps than any other. Those most interested in the introduction of the power wagon during these years were engineers; very few others were interested at all, and, in consequence, took the engineers' point of view on faith. For a matter of 10 years, hardly a month went by that we were not treated to the information that such and such an engineer had solved the power wagon question, whereas, as far as the engineer was concerned, it was already solved, as there is ample evidence to prove the superiority of the power wagon over all other kinds of road transportation, at least as long as 10 years ago. Whatever improvements the intervening time or the future may have made or will offer, the mere engineering problem could properly be considered to have been solved when the new method afforded superior convenience and economy over then existing methods without corresponding sacrifice.

The peculiar mental bias cited in the opening phrase, however, concentrated the attention of those interested upon the search for some engineering solution, and they were correspondingly diverted from any attempt to remove the true impediments to the introduction of the power wagon during that period, which were almost exclusively administrative, and psychological, and in a less degree financial. In view of the large number of former inventions which are publicly known to have gone through the same experience, the difficulty of diverting the attention of those interested as well as the public from the engineering question seems amazing when regarded in retrospect.

While the introduction of the power wagon has made some progress during the period named, it is still conservative to say that the surface has not been scratched. Power wagon failures are still being reported by people who are trying to use the new machine in the old way; who, unconsciously, are limiting the capacity of the power wagon by the practices of draft-animal days. The first electric pleasure vehicle I ever saw was supplied with a whip socket, for which the body-maker's only excuse was "Because we had always been in the habit of putting them on." A recent alleged failure of power wagons reported to me was almost as hopeless of cure as though the owner had insisted on putting oat-bins into his machine shop; in fact, the cause of failure was somewhat analogous. It is this that we have to contend with. It is mainly to overcome this mental attitude, directly or indirectly, that the Electric Vehicle Association of America was created—of course, as a means to another end, but, nevertheless, that is the direction in which its weapons have got to be directed if it is really to be of any service to its projectors. Unfortunately, it is not only going to be necessary to directly educate owners and prospective users of power wagons, but their employes, even to the drivers, who have in most cases got to modify their points of view and methods before the introduction of power wagons can be expected to be general.

Like much other labor-saving machinery, especially in the transportation field, the power wagon speeds the men up all along the line. The operators, although much fewer for a given product, have to work harder and faster, but almost invariably obtain their compensation from shorter hours, perhaps not in proportion, but still to an agreeable extent. The increased speed is the first thing the driver feels. It takes him some little time to find his own advantage.

A good illustration lies in a story which was told me by an Adams Express agent in Buffalo some 8 or 9 years ago. At that point and at that time, the Adams Express Company had the first really successful installation of electric vehicles. Owing to a poor selection of the size of the vehicles in relation to the routes covered and the service to be done, the station was not as economical as it could have been made, but it was at that time an exceedingly well-operated station, and in all probability was at that time, in spite of the above-mentioned handicap, delivering express packages more cheaply than it was being done anywhere else in the United States by any means whatsoever. When the wagons were first introduced, the drivers immediately felt the exactions of the greater speed; they felt themselves speeded up, and they were loud in their denunciations of the whole scheme. They rejoiced in every accident that occurred and took delight in the misfit electrical conditions under which, at first, the vehicles were charged. At the time I speak of, the whole station had changed. The drivers had discovered that instead of being dragged back from the last package on distant routes at a very slow rate by a tired horse, the electric express wagon now running light brought them back at even a faster rate than that at which it had been running during the day. As one of them said to me: "I can deliver all my packages now, and get home a half hour sooner than I used to." At that time, the express agent offered to buy a new team with brass-trimmed harness for any one of the electric wagon operators that would drive it, but it was rejected with scorn.

All this education takes time, and hardly anybody is addressing himself to try to bring it about.

Perhaps the commonest of all bad practices is that of applying the power wagon to a delivery route previously operated by a horse wagon of the same size, and limiting it thereto. The difference in the actual cost of operation between a given size of horse wagon and a given size of power wagon is seldom in favor of the latter, and this is true, also, of the first cost of the complete unit. The principal economical virtue of the power wagon lies in its character of labor-saving machine. Under almost all conditions the price of drivers is the largest single item of expense. Taking the station hands into consideration, the payroll is always the largest single item of expense.

## Efficiency in Delivery

The problem of the successful user of the power wagon then lies in the question of "How much goods can I deliver per man per day?" or, "How much work can I do with a man per day?"

It does not seem to take an Isaac Newton to realize that if the work of a man operating the new machine is arbitrarily limited to only what he can do with the old, nothing is gained. In all regular delivery systems, the problem is not only to lay out the routes to fit the new machine, but to select the machine sizes so that the largest possible machine that can be fully loaded will completely empty itself over a selected route in a man's day's work. This extremely simple mathematical thought seems to be almost incomprehensible to the majority of power wagon users. In some express companies, and others, whose principal business is city transportation, certain routes have become a positive institution, and, although usually originally of an entirely arbitrary selection, are assumed to be as immutable as the value of Pi. This sounds like a joke, but it is anything but a joke to those of us who have been frequently called upon to demonstrate the superiority of power wagons over draft-animals. Those who have not had the experience will be perfectly surprised at the

frequent high grade of intelligence which declines to rid itself of the inherent necessity of operating on these time-honored routes.

We are, however, occasionally treated to a refreshing case of independence and directness in the substitution of power wagons for horse service.

In the Fall of 1901, the Adams Express agent in Pittsburgh put in service at East Liberty a light electric express wagon, and in doing so gave instructions to the agent at that point, against the latter's protest, that he should lay off all four of his horse wagons, and do his work with the electric, that he (the Pittsburgh agent) would decide later whether he would allow him any of the horse wagons back or not.

This was certainly taking the bull by the horns; but, as the East Liberty agent's job was at stake, the result justified the risk, and only one wagon of the four was put back into service, and that only as an extra. Of course, the intention of this barn-yard approach could easily have been defeated had the size and speed of the wagon been unsuitable to the particular service to be performed.

A good example of what it means to speed up, not only the operators, but the daily routine and methods, is afforded by the ordinary practices of our great express companies when horses were a rule with them.

I have before me a careful plotting of ten established routes of different express companies in New York City made in the spring of 1902. You will probably be surprised to discover that from the time the horses left the barn in the morning until they got back at night, the teams were standing still 40.4 per cent. of the time, the maximum idleness on any one route being 64.25 per cent., the minimum 27.25 per cent. At least 50 per cent of this is due to the fact that the gait of the man matched the gait of the horse. The draft-animal belongs to a slow age, and the man who drove him as a rule adapted himself to it.

#### Man Takes Horse's Gait

If any one is in doubt as to the reality of this effect, let him observe the Egyptian plowman with his water Buffalo. The ordinary plowman is slow enough, but the Egyptian's movements suggest the chameleon. The ordinary draft-animal operator grades up from this on the way to the operators of machines. But the accessory facilities have also been accommodated to the draft-animal, and are, correspondingly, impeding its successor. The methods of loading and unloading and of handling packages, the shipping room arrangements and routine, and even the unnecessary time, assumed to be necessary, even with the existing facilities, are all adapted to the gait set by the horse, and all tend to deprive the machine owner of his advantage; and, remember, these speeds are not set to what the horse can do or necessarily actually does, but what he *may* do. Long practice has subconsciously led to their adjustment to the uncertainties of the horse in spite of the goad of competition. If you have to allow a half hour's leeway in 25 per cent of the cases in which a horse has to make a 2 hours' trip, what is the use of trying to save 15 minutes of a half hour's loading time?

This, roughly, illustrates the subconscious mental process by which all these measures accommodate themselves to the horse, and may indicate, generally, why they have all got to be changed before the power wagon will be generally acceptable without question. Those who have been through the experience cannot fail to recall the immediate effect of the use of the power wagon toward remedying this condition. The difficulty is to get the first one purchased and properly used.

I have before me a plot of the far-East Brooklyn route of the New York Transfer Company, both with horse service, and with electric vehicles. This involved the operation of what is known as a route-wagon, and no opportunity whatever was afforded at the time to modify the route, or take any other direct advantage of a labor-saving character of the power wagon. During the trip the team stood still 30 per cent of the time, but the power wagon stood perfectly still only 22¼ per cent of the time. The

actual difference between the idle periods of the two outputs was three-quarters of an hour, but the power wagon completed the service one and one-half hours before the team. Of course this wouldn't do.

The experiment was not made for the purpose of introduction in that instant, but, in combination with other available routes, indicated to the demonstrator at once the immense saving that could have been accomplished had the education of the drivers, and the speeding of the package handling, the proper arrangement of shipping rooms, and wagon interiors, to that end, and the reconciliation of wagon capacities and route arrangements been immediately begun. But, perhaps, it is too much to expect that the development of special mechanical facilities for loading and unloading will precede rather than follow the general introduction of the new method.

#### System a Great Essential

The reality of the impediment which present handling facilities interposes to the introduction of power wagons can be illustrated by a case I once came across of a high grade dry goods company in one of our largest cities, whose installation of electric vehicles could not be made to pay. Examination developed the fact that no effort was made to crate or handle the packages in the waiting room with any reference whatever to the respective routes upon which they were to be delivered, and that the routes were laid out with equal disregard to the shortest possible empty haul; following their practice with draft-animals, the wagons were driven to the opening points of the routes, and, extraordinary as it may seem, the packages were all taken out of the wagons, and spread along the beds of grass between the curb and sidewalk. Some of the wagons carried one boy, and some two boys—each with a large canvas bag. Each boy pawed over the pile of packages and selected and put in his bag the packages belonging to the block that he was to cover, and those that were left the driver took back into the wagon and drove to the point at which the boys were respectively expected to finish their bags. Rather than this, the firm should have abolished its entire wagon system and employed boys with bags to carry the packages to the destinations on public trolley cars.

To the credit of the owners I must say that they finally looked into it, and the difficulty was properly remedied with correspondingly successful result. This was, of course, an extreme case, and unusual in the use of the boys, and the sorting of the packages on the ground; but the shipping room arrangements were by no means unusual. In fact, inadequate loading or unloading facilities are almost universal. The simple convenience of a ready-loaded crate to slip into the wagon upon arrival is most uncommon, and such suggestions are almost invariably resisted—not for any reason, but because we haven't been accustomed to do so. It sometimes happens in large shops that packages of a certain large classification are of a size and character which admit of their delivery through chutes to the shipping room. It is almost invariably the case that by a slight change in the arrangements, the sorting of these packages according to wagon routes can be made once and for all on the floor where and when they are put in the chutes. But, as far as I know, it has heretofore proved impossible to induce anybody to do this, although I have yet to hear a valid objection offered to it in any case, and yet the delivery manager of such an organization often calls himself a business man, although he unhesitatingly keeps the most expensive unit of his investment standing idle, apparently, for no other object than to relieve the strain on his own ingenuity.

Many of these requirements could be made to improve the horse service if the horse himself had the endurance to stand it—a point that is frequently overlooked. As has often been said, there is no watt-meter on the horse, and, in consequence, he is generally worked more or less beyond his normal capacity, the loads and routes being more or less subconsciously selected to that end. To save this loading time, therefore, means to cut down the horse's cost, without which he cannot do the work

assigned to him, but the power wagon needs no rest in the same sense, and it is a large enough investment to make it desirable to conserve this time.

In considering this general question of reducing delays and loading times, it is often overlooked that the day's mileage is a rough measure of the work performed by a unit in a given service. An hour's delay on a 5-ton horse truck, averaging say  $2\frac{1}{2}$  miles an hour, may be a large percentage of a day's work in that unit, but measured in dollars it represents only a third of the loss represented by a similar period of idleness in a 5-ton power wagon whose average running speed is  $7\frac{1}{2}$  miles per hour.

It is very hard to persuade the average user that the idle periods in the day's work in any way affect a comparison of the draft-animal and power wagon.

The reactionary effect of external conditions goes deeper, and is far more nearly universal than the mere lack of facilities in individual establishments. For example:

#### The Alley Limitations

The dimensions of many of the down-town alleys in Chicago put a definite limit on the truck dimensions that can be used therein, and nearly all trucks working in that part of the city load or unload in the alleys. The peculiar arrangement of the railroad freight yards in Chicago curtails the efficiency of all methods of highway transportation to such a degree as to greatly dwarf the question of their relative advantages. Those who have investigated this particular case closely state that, it is no exception to the rules that the conditions can be perfectly well met by a rearrangement of these yards with direct reference to the use of automobiles with a probable improvement of 150 or 200 per cent in their loading and unloading capacity. It is reported that the railroads themselves are alive to the situation, and are approaching the solution in a more or less dilatory manner with an entire ignorance of the expert knowledge that is available on this subject in the automobile field.

There are many analogous cases throughout the country; many of them can probably be partially met by special portable loading apparatus of one kind or another applied to the trucks themselves. Next to the increase of factor of safety on operating cost to be obtained by improvement in tire maintenance on the heavier trucks, there is perhaps no single field in which the designing engineer, strictly so-called, could play as large a part in developing this business as right in this field of portable loading apparatus and the design of trucks with reference to special service. This is one of the few departments of automobile knowledge in which there is anything yet to be learned from draft-animal practice, or, rather from the practices that existed during the draft-animal period.

#### Fruit Handling Very Poor

Up to date the handling of fresh small fruits at automobile speeds has almost invariably entailed loss, and it is ridiculous to suppose that a little ingenuity properly applied would fail to immediately meet this case to which the improvement in speed and certainty offered by the power wagon gives the fruit handler a most obvious gain.

Nearly all the cotton in the Gulf ports, and throughout the South, is handled by negro roustabouts. It is fairly cheap and hard to beat for economy, but it is uncertain and sometimes too slow.

The condition has been partly met by the extension of railroad spurs; but about 2 years ago I knew of a very considerable order for electric 5-ton trucks that was lost because portable jib-cranes could not be applied to them in season to meet the conditions.

More could, of course, be said on this subject, but the examples are sufficiently indicative of the class. In the work of development in this direction, there is still a little to be learned from the practice which prevailed in draft-animal vehicles.

Mechanical ignorance on the part of prospective users, of

course, has got to be expected. At least in the electric field no one is in so fine a position to cope with this as the central stations, and many of them are doing yeomen's service in this direction; but we all remember the time when it was otherwise.

The first considerable installation of electric vehicles in this country was almost ruined because the Central Station manager in that particular instance looked upon the vehicle user as legitimate prey. It was an interesting thing to walk into the charging station at night and see a long row of red-hot cast-iron rheostats through each of which a vehicle battery was being charged in two groups in parallel and to know that the current was being obtained from a 110-volt d.c. circuit which was being metered at the customer's expense nearly three-quarters of a mile away. Even a persistent horse user cannot fail to sometimes discover something. He may have a nephew just from college. At all events, this enlightened proceeding caused the user to put in his own gas engine and generator, and, in consequence, cut the monthly cost of current per vehicle from \$38.00 to \$5.50.

It is hard to believe to-day that such a company, or such people, or such action could have belonged to an organization which is probably to-day doing more far-sighted work in the introduction of power wagons than any association anywhere, and many of whose members were even at that time actively alive to the prospect.

There are, of course, many minor considerations which tend to retard power wagon introduction, and some of them are of a very isolated character. For example: One user of electric livery wagons in New York still uses many horses, and he probably will as long as there is a sale for high grade coach horses, because he raises them and uses his wagons to break them in. This particular firm needs no instructions from anybody. They are as well informed on the economy of delivery, and as well organized, and as unprejudiced, as any wagon user we have come in contact with.

Then there is always the reactionary or interested delivery manager. I have in mind a case where electric trucks came to grief very largely, but not entirely, because the man in charge of them received a personal compensation for every horse wagon he was obliged to employ in excess of the electric installation. As a result of this situation an electric truck averaging about  $7\frac{1}{2}$  miles an hour round trip by cyclometer, found itself unable to deliver any more goods per day than a horse vehicle of the same capacity averaging  $2\frac{1}{2}$  miles per hour round trip by cyclometer. Whenever, as in this case, it looks as though the laws of nature were suspended to the detriment of the power wagon, it is a pretty certain indication that something of this kind is to be looked for. But apart from these minor, but almost universal, considerations which occur in endless variety, the principal obstacles will be found to be practically limited to those discussed more at length in the above paper.

#### Public Education Is Needed

The whole question of the rapid introduction of the power wagon to-day is one of public education. We have no right to look for any engineering advance so overwhelming as to relieve this condition in time to be of any great service in the work. The general lines along which experience has indicated this education to be necessary, I have endeavored to set forth above. No associations, no corporations, no individuals are in such a position to force this education as the central stations; and no one whatever, except possibly the team users, is likely to reap as great an ultimate profit by it. The liberal manner in which this central station business has been conducted during the last few years, and the local newspaper advertising involved thereby, means the availability of the press for educational purposes to a degree even greater than that justified by the public interest in the question.

The association seems to be thoroughly alive to this situation, and we have a right to hope that the next year will see results.





A few of the motor buses transporting passengers to and from Chicago depots

**COLUMBUS, O.**—Shields & Wiseman have opened a garage and repair shop at 241 West Fourth avenue, in this city.

**COLUMBUS, O.**—O. G. Roberts & Co., 933 East Gay street, have taken the central Ohio agency for the Stearns for 1912.

**URBANA, O.**—The Only Garage of Urbana, O., has taken the agency in Champaign county for the Ford 1912.

**WHEELING, W. VA.**—W. W. Price, proprietor of a garage in McCulloch street, will have an agency in this city for the Metz cars.

**CANTON, O.**—Monnett & Sacher, Canton, O., have taken the 1912 agencies for the Ford, Oldsmobile, Rambler, and Everitt lines for that territory.

**OAKLAND, CAL.**—Frank R. Fageol, distributor of Rambler cars in Alameda County has opened a handsome new sales-room on Telegraph avenue.

**PHILADELPHIA, PA.**—An announcement is made of the removal of the United States Motor Company to its new quarters at 216-218 Broad street.

**PORTLAND, ORE.**—H. L. Keats of this city has secured another agency. His latest acquisition is the Chase commercial vehicle, for which he has the northwest distribution.

**HAGERSTOWN, MD.**—The Hagerstown Garage Company, will handle the line of 1912 Pullman cars. The company has recently built a large garage on the main street of Hagerstown.

**COLUMBUS, O.**—A change in the management of the High-Seventh Garage, located at High street and Seventh avenue, was made recently when Norman M. Johnston assumed the management, succeeding J. W. Fritz.

**COLUMBUS, O.**—R. C. Westcott, 972-976 North High street, has arranged for the 1912 agency for the Regal. The territory covers seven counties in central Ohio, a portion of which will be covered by sub-agencies.

**PORT HURON, MICH.**—George Yokom's new garage on Military street, when completed, will be able to accommodate 300 cars. The building will be 50x100 feet and will be of concrete and brick.

**PORTLAND, ORE.**—Edward E. Gerlinger, of the Stoddard-Dayton Auto Company, has secured the distribution for this city and the adjacent territory on the Pathfinder car. In addition to these two cars he will handle the Federal truck.

**PORTLAND, ORE.**—The Oregon Brush Auto Company, local agents for the Brush line, and the Landy Auto Company, Portland agents for the Garford cars and the foreign Napier, have recently leased new quarters at 31 Alder street.

**CLEBURNE, TEX.**—The material for the erection of the new factory that is to be built here for the manufacture of automobiles, by H. E. Luck and associates, has arrived on the ground and the work of putting it in place is to be pushed.

**COLUMBUS, O.**—J. P. Adamson & Company, 35 West Mound street, Columbus, O., has taken the 1912 agency for the Dart delivery wagon, manufactured at Waterloo, Iowa. The territory embraces ten counties in the central part of the State.

**BOSTON, MASS.**—The United States Motors Company has taken over the Stoddard-Dayton branch. The management will be in charge of Frank J. Tyler, E. H. Lucas will have charge of the retail department, and E. P. Weber of the wholesale department.

**WICHITA FALLS, TEX.**—The Wichita Motor Company has received the machinery for the factory that it is erecting here to manufacture automobiles. The mechanics that are to be employed in the plant have arrived from Detroit, Mich. The company will at present devote its plant exclusively to the manufacture of auto trucks.

**PRINEVILLE, ORE.**—H. C. Farris, formerly of Moline, Kan., has recently made partnership arrangements with J. F. Jacker of this city. This company will conduct an express business in the vicinity of Prineville, Ore. Two two-ton Kelly trucks have been installed and will be used to transfer freight, baggage and express from Madras, Opal City, Redmond and other railroad points on the Oregon Central to Prineville.

**BALTIMORE, MD.**—The Lord Baltimore Motor Car Company, 1523-25 Retreat street, is making preparations to move the motor truck plant from the monumental city and will probably locate in York, Pa. Jacob Baumann, general superintendent, and John Luntz, Jr., proprietor of the factory, were in York last Saturday looking over a number of sites and interesting capitalists in a project to move the plant here. Messrs. Baumann and Luntz left Baltimore Friday morning at 11 o'clock and arrived in York at 4:30 o'clock in the afternoon in a three-ton motor truck via the Baltimore turnpike. The men experienced some bad roads on the trip especially between Cockeysville and Parkton, where the pike had been torn up for a distance of about 10 miles. The men made a stop of about an hour to repair the fan on the truck and an hour and a half at Parkton for dinner. The entire distance was made on high gear and the actual running time was about 3 hours, or at the rate of 19 miles per hour.

**NEW ALBANY, IND.**—The Borgerding Motor Car Company will sell the Ford in this city.

**LOUISVILLE, KY.**—J. M. Robinson-Norton & Company, have taken the agency for the Motor Wagon.

**YORK, PA.**—H. S. Nagle, of Wilkes-Barre, has taken the agency for 1912 line of Pullman cars.

**KALAMAZOO, MICH.**—Arthur Fiske and Harry Parker have taken the agency for the Lion automobile.

**CHARLEROI, PA.**—The Spencer Auto Garage has signed up the Franklin dealership for the coming season in this locality.

**WASHINGTON, D. C.**—After extensive alterations the Buick Motor Company has opened new salesrooms at 1028 Connecticut avenue, N. W.

**TACOMA, WASH.**—John N. Ball has recently announced the acquisition of the western Washington territory on the Columbia car, with headquarters in this city.

**INDIANAPOLIS, IND.**—Brandt Brothers, who have been agents for the Lozier in Indianapolis and vicinity for some time, have also taken the agency for the Hupp-Yeats electrics.

**PHILADELPHIA, PA.**—The Eastman Motor Truck Company has established temporary quarters at 1141 South Broad street, for distribution in Philadelphia and vicinity of the Wilcox Truck.

**SEATTLE, WASH.**—Realizing that the Pacific Northwest is a rich field for the commercial truck, the Mais Motor Truck Company, is about to establish the Northwest headquarters in Seattle.

**WASHINGTON, D. C.**—The Wilson Company, agents for the Cole and Krit, has leased the building at 918 Fourteenth street, N. W., and after extensive improvements, will take possession.

**BALTIMORE, MD.**—Plans are being prepared for the removal into new quarters by C. R. Mizner, Baltimore representative for the Oldsmobile. The new quarters, consist-

ing of an up-to-date showroom and machine shop, are located at 1419 North Charles street.

**MACON, GA.**—Plans have been perfected for the transfer to this city of the Howard Automobile Company of Jackson, Mich. General Manager J. E. Keith of this company has announced that work will begin in a very short time upon a new factory to cost \$200,000.

**SEATTLE, WASH.**—As the result of a visit of Chas. P. Henderson, general manager of the Henderson Sales Company, to Seattle, negotiations were completed with the F. H. Barshar Company, of 1107 East Pike street to handle the Cole products in Seattle and western Washington.

**COLUMBUS, O.**—Alleging debts in excess of \$1,000 a petition has been filed against the Radio Manufacturing Company of Columbus, O., asking that the company be declared bankrupt. The Radio Manufacturing Company was recently formed to manufacture automobile parts and accessories.

**SEATTLE, WASH.**—Charles R. Williams, who is well known to the automobile fraternity through his 2 years' connection with the Northwest branch of the Winton Motor Car Company in Seattle, has recently established the Auto Brokerage Company, at 307 East Pike street.

**TOLEDO, O.**—The Willys-Overland Company, this week through its attorney Rathbun Fuller, filed with the city council of Toledo, a petition asking for the vacation of a number of streets and alleys in Cycledale addition. The company is now in possession of this entire addition to the city and as soon as the streets and alleys are vacated will erect a number of large additions to its plant.

**WASHINGTON, D. C.**—Uncle Sam is in the market for 2 motor-driven combination fire engine and hose wagons to be used in the Panama canal zone. Bids for furnishing the fire apparatus will be opened by the Isthmian Canal Commission in Washington, on October 30. Rigid specifications for the machines in question have been

drawn up and it is stipulated the machines must conform in every particular with the specifications.

**BALTIMORE, MD.**—Plans have been made by the Mar Del Mobile Company for an extension of The Garage, Mt. Royal avenue and Charles street. The proposed addition will be 62 x 120 feet, which, with the present building, will give the garage a floor space of 100,000 square feet. This addition will afford a separate room for furnishing gasoline for motor cars in which a number of machines can be supplied simultaneously and a repair room with machinery and appliances.

**INDIANAPOLIS, IND.**—The Manufacturers' Bureau of Indiana, which includes in its membership 1,200 manufacturing concerns of the State, has taken up the question of organizing an employers' mutual liability insurance company. Companies writing employers' liability insurance in Indiana have advanced their rates 40 per cent. since January 1, owing to recent changes in the employers' liability law. The bureau has appointed a committee to report within 60 days some plan for forming a mutual company.

**NEW YORK, N. Y.**—Mr. A. Massenat, who has represented the Panhard and Levassor Company in this country for many years, formally announced his retirement from active control. Mr. Gustave Prost, who has for some time been connected with the concern, will take active control. He has been with the American Branch of Panhard and Levassor for seven years. Howard S. Hamilton will occupy the position of assistant manager and will have charge of the sales department, assisted by Herbert K. Levick.

**KOKOMO, IND.**—The Kokomo Rubber Company has been reorganized, F. I. Willis of Indianapolis, and G. H. Hamilton, until recently New York agent for the Continental Rubber Co., having bought stock in the concern. Officers of the reorganized company are: President, D. C. Spraker; vice-president F. I. Willis; treasurer, D. L. Spraker; secretary, William F. Langdon



The selling force of the Flanders company as it met at the New York headquarters



The recent automobile accident in Paris—hoisting up the auto bus which fell into the Seine

and sales manager, G. H. Hamilton. A reorganization of the Hearshey-Willis Company, of Indianapolis, has also been found necessary, F. I. Willis, who has been secretary and treasurer, becoming vice-president. Robert H. Colburn, has been elected secretary and treasurer of the company.

CHILlicothe, O.—The ArBenz Car Company is the new name recently adopted by the Scioto Auto Car Company.

MONTGOMERY, ALA.—The Drennan Motor Car Company of Jefferson County, has increased its capital stock from \$5,000 to \$50,000.

DETROIT, MICH.—E. J. Miles has been placed in charge of the experimental department of the Studebaker Corporation. He is a metallurgist of large experience.

CLEVELAND, O.—The Judd Automobile Company, 1206 Huron Road, has added to its general garage and salesroom a tire repair shop known as the Judd Tire Company.

DETROIT, MICH.—Joseph E. Warren has associated himself with the Metzger Motor Car Company and will be chief of district managers, under sales manager W. C. Hood.

MILWAUKEE, WIS.—The Smith-Hoppe Auto Company, 114 Mason street, has been appointed state agent for the R. C. H. car. The firm now represents the Hupp-Yeats electric, Oakland and Oldsmobile.

MEMPHIS, TENN.—H. R. Stone was appointed receiver of the Hazen Automobile Company by Chancellor Francis Fentress. A bill filed against the company by the Security Bank and Trust Company was declared a general creditor's bill.

DETROIT, MICH.—The Goodfellow Tire Company has given a trust mortgage to

Austin L. Richardson, as trustee, to secure creditors with claims aggregating \$6,000. The mortgage covers the concern's plant at Woodward avenue and the Boulevard.

DETROIT, MICH.—The entry of the Ford Motor Company into the manufacture of light delivery wagons is one more example of the turning of attention to makers of commercial vehicles. The Ford delivery wagon is built on the model T chassis and uses the left-hand control as in the touring car.

CITY OF MEXICO, MEX.—It is reported that a syndicate of Americans, headed by L. H. Morrison, formerly of Indianapolis,

will establish a large plant in Mexico for the manufacture of automobiles. Application for a concession for the proposed plant will be made to the federal government. The factory will be located either in this city or in Monterey, it is stated. The demand for automobiles in this country is rapidly increasing. At present many of the cars are brought from Europe.

MILWAUKEE, WIS.—A number of Milwaukee dealers took advantage of the opportunity offered by the holding of the International Dairy Show in Milwaukee last week to make exhibits for the benefit of dairymen and agriculturists. Among those who had exhibits was George W. Browne, State agent for the Overland; the Milwaukee branch of the Buick Motor Co.; Bates-Odenbrett Automobile Co., Abbott-Detroit, and the Charles Abresch Co., Halladay and Colby. The Abresch-Cramer Auto Truck Co. exhibited a line of commercial vehicles.

RACINE, WIS.—The Mitchell-Lewis Motor Co., of this city, has elected to come within the provisions of the new workmen's compensation or industrial insurance act passed by the last Wisconsin Legislature. The company employs more than 2,000 workmen. The law eliminates litigation and the incident expenses of suits and the industrial commission fixes the rates of compensation for injury and death from accidents in the line of duty. Motor car manufacturers as a class receive the benefit of exceptionally low rates in the schedule recently prepared by the commission, as the occupation is considered less hazardous than most other industries. The Mitchell-Lewis Co. is the first Racine industry to apply for the rights under the new law, which is optional with employer as well as employee.



The prince of Phaumagar, India, enjoys riding in a Ford which is driven by a native chauffeur

DETROIT, MICH.—A service department has been established by the recently organized General Motors Truck Company, with T. P. Myers in charge as general service manager.

SYRACUSE, N. Y.—The Syracuse Motor Car Company has the agency for the Ford output in this city and has just received a new style delivery wagon, it being a closed car of 20 horsepower and having a capacity of 700 pounds.

AKRON, O.—A meeting of Swinehart branch managers, salesmen and agents was held September 29 and 30, at the office of the factory. There were more than forty in attendance. Plans and the policy for the ensuing year were discussed and agreed upon.

DETROIT, MICH.—S. L. Stone has tendered his resignation as assistant sales manager of the Oakland Motor Car Company, of Pontiac, to become general manager of the Centaur Motor Company, of Buffalo, which handles Oakland cars in western New York and Pennsylvania.

MILWAUKEE, WIS.—Leslie D. Flint has become associated with the Wisconsin Auto Sales Company, distributors for the Westcott, National, Herreshoff and Cutting. Mr. Flint will be in charge of the Westcott sales in Minnesota, Iowa, the Dakotas and Montana, with headquarters in Minneapolis.

JEFFERSON, WIS.—The Kenzler-Waverly Motor Company, a consolidation of the Kenzler-Waverly Motorcycle Company, of Cambridge, Wis., and the Waverly Motor Manufacturing Company, of Milwaukee, Wis., has accepted the proposition of the Jefferson Promoters' club to locate the consolidated works in this city. The plant will be in operation by December 1.

KENOSHA, WIS.—The Purdy Garage Company has been incorporated here to succeed to the business of the Kent Motor Car Company, which was recently purchased by Frederick Purdy. The Kent garage on Church street will henceforth be known as the Purdy Garage. C. H. Nellis, who was associated with the Kent brothers has joined the Purdy company.

CHICAGO, ILL.—The Chicago Motor Transportation Company, a \$3,000,000 corporation, has dispensed with its horse-drawn 'buses between the depots and the retail section of the city and has introduced motor 'buses, each of which has accommodation for eighteen passengers besides the driver. These are pay-as-you-enter 'buses with a side entrance on the right and an exit in rear. The fare from the depots to any of the large stores is 10 cents. This is in strong contrast with a fare of 50 cents for horse-drawn cab service. The new 'buses operate on a regular time schedule over a definite route. The 'bus bodies are built on 1 1-2-ton White chassis.



The 4 1/2-ton Commer truck which made a fine economy showing during the recent Boston truck contest

DETROIT, MICH.—The Studebaker Corporation entertained dealers from New York and the New England States during the past week, general manager Flanders acting as host.

SHERMAN, TEX.—F. D. Welch of Amarillo and P. M. Shelton of Grayson county have formed a partnership and opened the Sherman Automobile and Vulcanizing Company at 207 East Houston street.



## Automobile Incorporations

### AUTOMOBILES AND PARTS

BOSTON, MASS.—Amplex Motor Co. of New England; capital, \$25,000; to deal in automobiles. Incorporators: I. B. Spafford, Wm. Turner, Wm. B. Foster.

BROOKLYN, N. Y.—Osgood Motor Car Co.; capital, \$10,000; to make and deal in automobiles and supplies. Incorporator: Samuel H. Miskind.

CHICAGO, ILL.—South Shore Garage Co.; capital, \$12,000; to deal in taxicabs and automobiles. Incorporators: Chas. M. Mudge, L. C. Zward, E. A. Fleming.

EVERGREEN, ALA.—Evergreen Motor Car Co.; capital, \$2,000; to sell motor vehicles. Incorporators: C. P. Deming, H. W. Dunn and R. L. Whitcomb.

FORT WAYNE, IND.—Fort Wayne Auto Motor Co.; increased capital from \$50,000 to \$100,000.

GRAND RAPIDS, MICH.—Cogswell Motor Car Co.; capital, \$10,000; to make automobiles and parts.

LAFAYETTEVILLE, N. C.—Consolidated Motor Co.; capital, \$25,000; to make and deal in automobiles. Incorporators: H. Lutterloh, I. U. McKethan.

LINTON, IND.—Linton Garage Co.; capital, \$10,000; to sell automobiles. Incorporators: A. T. Custer, G. C. Porter, T. J. Holden.

NEW YORK CITY—Paul Lacroix Automobile Co.; capital, \$10,000; to make and sell motor vehicles. Incorporators: Paul Lacroix, Harry U. Kibbe, Harvey T. Andrews.

NEW YORK CITY—Harger Steam Truck Co.; capital, \$1,000,000; to manufacture and sell all kinds of vehicles. Incorporators: John S. Harger, Walter S. Wheeler, George F. Conis, James L. Weir, Gilbert E. Ofeldt.

NOWATA, OKLA.—Nowata Motor Car Co.; capital, \$2,500; to sell automobiles. Incorporators: Walter K. Campbell, George Gordon.

OSWEGO, N. Y.—Motor Specialties Co.; capital, \$175,000; to make engines and automobiles. Incorporators: Arthur Lovell, Howard H. Williams, H. V. Walsh.

PENDLETON, IND.—Förse Manufacturing Co., manufacturer of parts, increased capital from \$25,000 to \$40,000.

PETERSBURG, VA.—Overland Sales Co.; capital, \$5,000; to sell automobiles. Incorporators: T. J. Burgess, D. P. Weeks, D. H. Burgess.

PHILADELPHIA, PA.—Wm. H. Godshall Co.; capital, \$15,000; to make automobiles.

TOLEDO, OHIO—Ford Bros. Auto Sales Co.; capital, \$10,000. Incorporator: Guy R. Ford.

WICHITA FALLS, TEXAS—Wichita Motor Co.; to manufacture automobile trucks.

### AUTOMOBILE GARAGES, ACCESSORIES

BUFFALO, N. Y.—James G. Barclay, Inc.; capital, \$25,000; to manufacture and sell accessories. Incorporators: James G. Barclay, Estella Barclay, George M. Kohl.

CAMDEN, N. J.—Eureka Double Resilient Tire Manufacturing Co.; capital, \$25,000; to make automobile tires. Incorporators: Gideon S. Adams, Harry Fox, John B. Fox, Edwin S. Orr, George Clements.

CHICAGO, ILL.—Chicago Motor Omnibus Co.; capital, \$1,000; to operate omnibuses. Incorporators: Henry P. Schandler, J. M. Johnston, K. Cornwell.

CHICAGO, ILL.—University Taxi Service Co.; capital, \$2,500; to operate taxicabs. Incorporators: Frank H. Drury, W. Perry Hahn, Walter D. Launder.

CLEVELAND, OHIO—Broadway Garage & Livery Co.; capital, \$10,000. Incorporator: Frank Paprock.

DONALDSONVILLE, LA.—Donaldsonville Garage & Automobile Supply Co., Ltd.; capital, \$10,000; to do garage and accessories business. Incorporators: James P. Kock, A. A. Sarradet, Adolph Netter.

JERSEY CITY, N. J.—Sterling Top & Equipment Co.; capital, \$50,000; to manufacture automobile equipment. Incorporators: Frank Grundy, Wm. C. Kands, George Copp.

NEW YORK CITY—Kelly-Springfield Rubber Tire Co.; capital, \$10,000; to deal in rubber tires. Incorporators: Albert O. Briggs, Chas. W. Stapleton, Richard Condon.

PEORIA, ILL.—C. W. Haas Tire Seal Co.; capital, \$50,000; to make automobile tires and rubber goods. Incorporators: C. W. Haas, R. C. Uckens, Emmet C. May.

RICHMOND, VA.—Louis Bremm Estate; capital, \$7,000; to build garage.

SAN DIEGO, CAL.—Savage Tire Co.; capital, \$1,000,000; to manufacture steel automobile tires. St. Louis, Mo.—Wrought Iron Range Co.; capital, \$3,000; to build garage.

SHERMAN, TEX.—Sherman Automobile & Vulcanizing Co. Incorporators: F. D. Welch, P. M. Shelton.



# OF INTEREST *to the* INDUSTRY



The new type of 700-pound delivery wagon constructed by the Ford Motor Company for the 1912 season.

**INDIANAPOLIS, IND.**—Cole 30-40 automobiles will be handled by a number of new agencies among which are the Cole Motor Company, of Wichita, Kan., Ohnhaus Automobile Company, Fort Wayne, Ind., The Norcross Garage, Worcester, Mass., Central Auto Company Terre Haute, Ind., Curtiss Scofield, Newark, N. Y., Baker Bros. Motor Car Company, Buffalo, N. Y., The Penn Auto Company, Scranton, Pa., Burke Motor Car Company, Chattanooga, Tenn., C. A. Winter, Wellsville, Kan., Fred Bihl, 220 Dolorosa street, San Antonio, Tex., and The Philadelphia Motor Company, Philadelphia, Pa.

**BALTIMORE, MD.**—The A. G. Alford Sporting Goods Company, 212 East Baltimore street, has the exclusive agency for Ajax tires.

**BALTIMORE, MD.**—Among the latest cars added to the local field is the Cutting. The agency for this district has been placed with the Rice Garage.

**FALL RIVER, MASS.**—T. N. Paquin & Sons, South Main street, Fall River, Mass., have been appointed Kissel agents for Fall River and locality.

**NEW BEDFORD, MASS.**—A. E. Perron, 900 Belleville avenue, has been appointed selling agent for the Kissel cars and trucks for New Bedford and vicinity.

**PROVIDENCE, R. I.**—The Kissel Kar Company has been appointed selling agent for the Kissel line of cars and motor trucks for the city of Providence and vicinity.

**KANSAS CITY, MO.**—The J. A. Davis Motor Car Company has taken the agency for the Thomas line. Mr. Davis has been

connected with President Chalfant of the Thomas company for over eight years.

**AKRON, OHIO**—Fred Kast has been appointed manager of the Cleveland branch of the Firestone Tire & Rubber Company. Mr. Kast is an Akron man and has for some time been at the Chicago branch of the same concern.

**DETROIT, MICH.**—The Ford Motor Company has recently established branches at Memphis, Tenn.; Los Angeles, Cal.; San Francisco, Cal.; and Vancouver, B. C. These cities will be Ford headquarters in the respective territories.

**PROVIDENCE, R. I.**—The Rhode Island Licensed Automobile Dealers have announced the date for the coming Providence show, which will be held in the Providence State Armory, from January 22 to 28. The main drill hall, having an area of 38,000 square feet, will be used to display pleasure cars, and half as much space will be devoted to commercials.

**AKRON, OHIO**—At the annual convention of the Firestone Tire & Rubber Company, which was recently held in this city, announcement was made that the factory which has just been completed at a cost of \$1,250,000 will be devoted to the manufacture of tires while the old plant will be used in making rims.

**NASHVILLE, IND.**—Dr. F. L. Musselman, of Trafalgar, Ind., who recently purchased a sanitarium here, is planning to operate a motor 'bus line from Nashville to Bloomington, Columbus and Franklin, as Nashville is without railroad connections. A general motor car passenger carrying

business will be conducted along this route.

**BALTIMORE, MD.**—Harry N. Baetjer and G. Ridgely Sappington have been appointed receivers for the Pullman-Shaffer Motor-car Company in the United States District Court here. The petition for the appointment of receivers was filed by the Chesapeake Tire and Rubber Company and the Baltimore Buggy Top Company.

**CHICAGO, ILL.**—The Cadillac Automobile Company, local representative of the Cadillac, has decided to erect a new five-story building at the northwest corner of Michigan avenue and Twenty-third street, opposite the Thomas branch. It is expected the new building will be completed by January. The lot is 75 by 165 feet and the Cadillac has a 20-year lease. The investment will total \$275,000.

**FINDLAY, OHIO**—Another big plant in the Middle West will be added to the chain of properties constituting the United States Motor Company by the establishing of a special factory to manufacture parts for the Maxwell-Briscoe Motor Company, the Columbia Motor Company, the Dayton Motor Car Company, the Brush Runabout Company and the Alden-Sampson Manufacturing Company. A representative has already visited Toledo.

**PHILADELPHIA**—In the purchase of fifty Packard trucks by the Acme Tea Company there is recorded what is said to be the largest single order for motor vehicles ever placed in the United States if not in the world. The order was booked by the Packard Motor Car Company of Philadelphia. It calls for thirty three-ton trucks and twenty of the one and one-half to two-ton size. The purchase represents an investment of about \$150,000.

**BOSTON, MASS.**—Charles G. Andrews and M. A. Dykeman have formed a partnership named Andrews, Dykeman & Company, to handle the Moon cars in the Hub. Mr. Andrews has handled the Moon as a sub-agency, but the new firm will have the entire New England territory. Salesrooms have been secured in the motor mart, Park square, formerly used by the Alco and Stoddard-Dayton agencies. Mr. Dykeman has sold, among others, Stevens-Duryea cars.

**PITTSFIELD, MASS.**—A special stockholders' meeting of the Jacobson-Brandlow Company voted to increase the stock from \$25,000 to \$95,000, and it was decided to have five instead of three directors. Douglass P. Wesson, of the Smith & Wesson Company, Springfield, Mass., was elected a director and Harry G. Tucker, formerly with the Curtis Publishing Company, was also elected a director. The officers of the company are as follows: E. B. Jacobson, president and general manager; Douglass P. Wesson, vice-president; Harry G. Tucker, treasurer.



# PATENTS GONE TO ISSUE

**ENGINE-STARTER.**—An apparatus operating by means of an air and fuel pump.

This device (Fig. 1), which is used in combination with an internal combustion engine and a source of fuel, contains an air pump which is connected to the engine and a fuel-measuring device connected to the source of fuel. The pump consists of a cylinder, piston and a manually operable plunger connected with the piston. The fuel measuring device is in shape of a valve having abutments which co-operate when the plunger is at its inward position, so that the valve may be turned by the plunger. The valve is adapted to discharge into the connections between engine cylinder and fuel supply.

No. 1,005,541—to Edward A. Halbleib, Rochester, N. Y., assignor to Northeast Electric Company, Rochester, N. Y. Granted October 10, 1911; filed December 16, 1910.

**LAMP-DIMMING DEVICE.**—Burner is movable by hydraulic pressure.

The construction protected by this patent is a combination of a lamp and reflector with a burner normally located opposite the reflector. The burner has a laterally projecting member, and by means of a fluid forced against this member the burner may be moved from its position opposite the light reflector. Means are also provided to limit the movement of the burner from its normal position.

No. 1,005,197—to Warren A. Greenlaw, Melrose, Mass. Granted October 10, 1911; filed January 3, 1911.

**RUNNING-GEAR.**—A method of chassis suspension for motor vehicles.

2. This patent refers to the combination of a frame, a front axle, an upper connecting member on the under side of the frame and a lower connecting member having its center housed within the upper

member and its ends arranged over the ends of the axle. Through the centers of the members a sleeve is so inserted as to pivotally connect same, springs being arranged between the ends of the lower member and the axle, and bumpers between the upper and lower connecting members; there are also springs provided on the bumpers mentioned.

No. 1,005,171—to David M. Dearing, Jackson, Mich. Granted October 10, 1911; filed November 12, 1909.

**LIFTING JACK.**—Worm wheels and friction device are combined in jack construction.

3. This jack (Fig. 4) contains a standard in which a vertical lifting screw may be raised or lowered. A worm wheel is rigidly secured to the screw. A removable hanger is adapted to be mounted on the lifting cylinder or standard, and it carries a horizontally disposed worm which is operated by a crankshaft. The hanger also carries a friction device adapted to engage the crankshaft when the shaft is rotated in one direction.

No. 1,005,479—to Herrman A. Schatz, Chappaqua, N. Y., assignor to Acme Ball Bearing Company, Chappaqua, N. Y. Granted October 10, 1911; filed January 17, 1908.

**CARBURETER.**—Having two fuel reservoirs.

4. The carbureter (Fig. 5) to which this patent refers contains a main reservoir, a mixing chamber adapted to communicate therewith, a fluid inlet to the reservoir and a mixture outlet from the mixing chamber. An auxiliary reservoir is provided which has communications with the main reservoir and the mixing chamber; the auxiliary reservoir has an air inlet adapted to discharge air beneath the fluid level therein. There is provided a main air valve and a port of exterior of the air valve adapted

to deliver a supply of air and fluid from the auxiliary reservoir to the outlet.

No. 1,005,491—to Alfred Weiland, Philadelphia, Pa. Granted October 10, 1911; filed January 21, 1909.

**COMBINED SIGNAL AND SIGN DISPLAY LAMP.**—System for automobile tail lamps.

1. The patent relates to a frame for holding individual interchangeable letter or number plates, comprising ends, top and bottom having parallel inwardly projecting flanges at their opposite front and rear edges forming longitudinal slideways for the plates, the top being provided with an opening at one end to admit one plate at a time into the slideway, a method of securing the closing means in place over the opening.

No. 1,005,306—to Almor Manor Puckett, San Antonio, Tex. Granted October 12, 1911; filed December 1, 1910.

**INTERNAL COMBUSTION ENGINE.**—Construction of the Diesel compressed-air ignition type.

1. The patent relates to the combination, in an engine of the type mentioned, with the engine cylinder, of a combustion chamber in which is arranged an atomizer nozzle containing a cut-off valve, which is normally held in closed position. A pump is provided to force a liquid fuel through the nozzle past the cut-off valve; an overflow valve is also provided, as well as an operating lever for the pump actuated from the engine shaft. On a stud is mounted adjustably an eccentric, on which again is mounted a regulating lever adapted to control the overflow valve. A link connects the regulating lever with the one controlling the pump, whereby overflow valve and pump are operated according to the speed of the engine.

No. 1,005,457—to Friedrich Oberhaensli, Bregenz, Austria. Granted October 10, 1911; filed November 28, 1910.

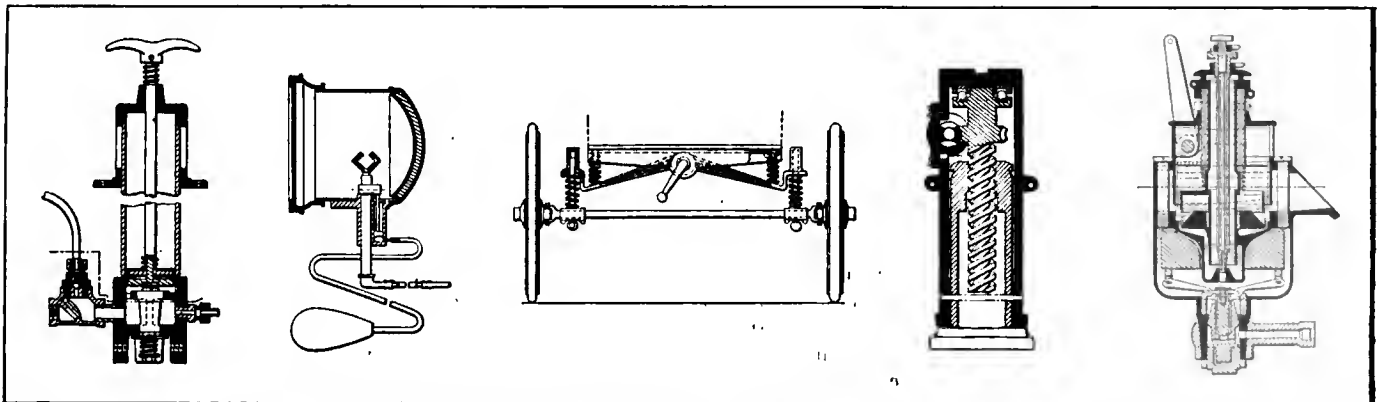

Fig. 1—Halbleib starter. Fig. 2—Greenlaw dimming device Fig. 3—Dearing running gear. Fig. 4—Schatz jack. Fig. 5—Weiland carbureter

# Newest Ideas Among the Accessories

## Rapid Engine Cleaner

THE cleaner depicted in Fig. 3 serves for removing grease and dirt from parts of the automobile accessible or otherwise. One gallon of the cleaning fluid, which may be kerosene, gasoline or

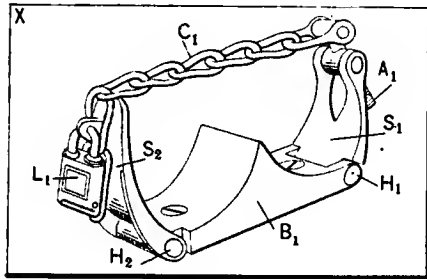

Fig. 1—B-A tire lock

tar oil, is filled into the tank through the filler hole ordinarily closed by means of filler cap F1, which is put in place after this operation. The tank is 20 inches high and has about 7 inches diameter. Then the pump P1 is worked, the air being led to the top of the tank where it presses on the liquid. This operation is continued until the gauge G1 on the top of the tank shows about 90 or 100 pounds. There is no difficulty in pumping up to this pressure in about five minutes, after which the tank is ready for use. If now the two cocks C1 and C2 are opened, the compressed air in the tank forces the oil up through the tube T1 and then through the hose H1 to the nozzle N1, where it is expelled in the form of a solid and fine but powerful jet. This will be efficacious in removing dirt, etc., if directed against the object to be cleaned. The

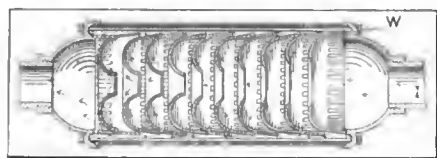

Fig. 4—Miller multi-chamber muffler

Rapid Auto Engine Cleaner is handled by Asch & Co., 1777 Broadway, New York City.

## B-A Tire Lock

The device shown in Fig. 1 is the new tire lock made by the B-A Specialty Co., New York City, and marketed by Asch & Co., of 1777 Broadway, in the same city. Referring to the illustration, it is seen that the lock consists of a cast steel base B1 having a central divide to accommodate two tires. To this base two drop-forged

shackles S1 and S2 are hinged at H1 and H2, and chain C1, which is of hardened steel, is fixed to S1 by means of the adjustable link A1. This chain is laid over the tires carried in the lock, and fixed to shackle S2 by padlock L1. The chain is long enough to accommodate any size of tires; the lock is finished in hard rubber.

## Acme Torsion Springs

The Acme torsion springs, shown in Fig. 2, are designed to prevent road shocks and vibration from being transmitted to chassis.

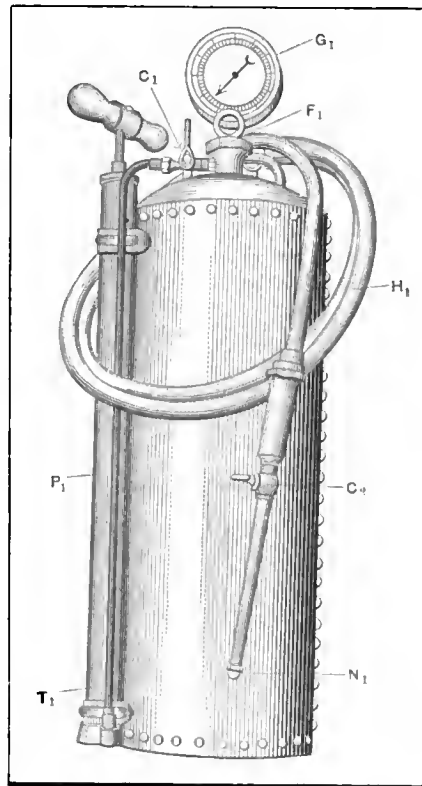

Fig. 3—Rapid engine cleaner

engine and body of the car, and to thereby relieve the tires of the shock absorbing service that is very frequently placed upon them. In the illustration Acme coiled springs are shown applied to the rear springs of the car, in place of the links connecting the leaf springs to the chassis frame. This work is easily done while the automobile is raised up on jacks, and the same bolts which hold the connecting links secure the torsion springs to the frame. It is necessary to lubricate the bolts copiously lest they suffer from the vast amount of work they have to do. The springs, which are manufactured by the Acme Torsion Spring Co., of Boston, Mass., are handled in the Metropolitan district by Frank Halpin, 9 Church street, New York City.

## The Miller Muffler

The Miller muffler, shown in Figs. 4 and 5, is of the multi-chamber type and of cylindrical form. The exhaust gases of the motor enter on one end and after passing through eleven separate

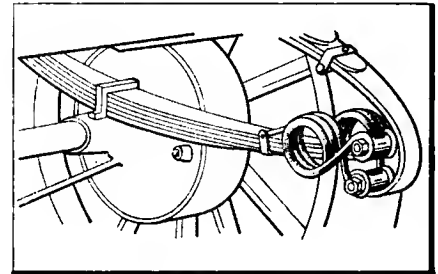

Fig. 2—Acme torsion spring

chambers leave at the other. The chambers are all of the same diameter, and stamped of steel in the shape of cups. As Fig. 4 shows, the entrance of each individual chamber is larger than its exit, so that part of the gases entering a chamber is bound to strike the rounded portion of the opposite wall, which is highly polished and imparts to the gases a whirling motion. This principle of operation is illustrated in Fig. 5, and the construction of the chambers forces the gases to leave them through the lateral passages and flow to the muffler outlet along the wall W (Fig. 4), because the central chamber outlets do not permit of passing of all the exhaust through them.

The whirling motion in the chambers serves to cool and expand the gases, and thereby to use up the inherent energy of the exhaust. Since the curved portions of

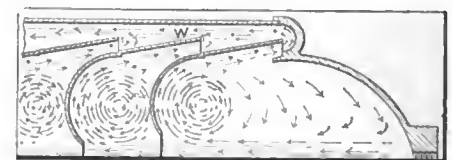
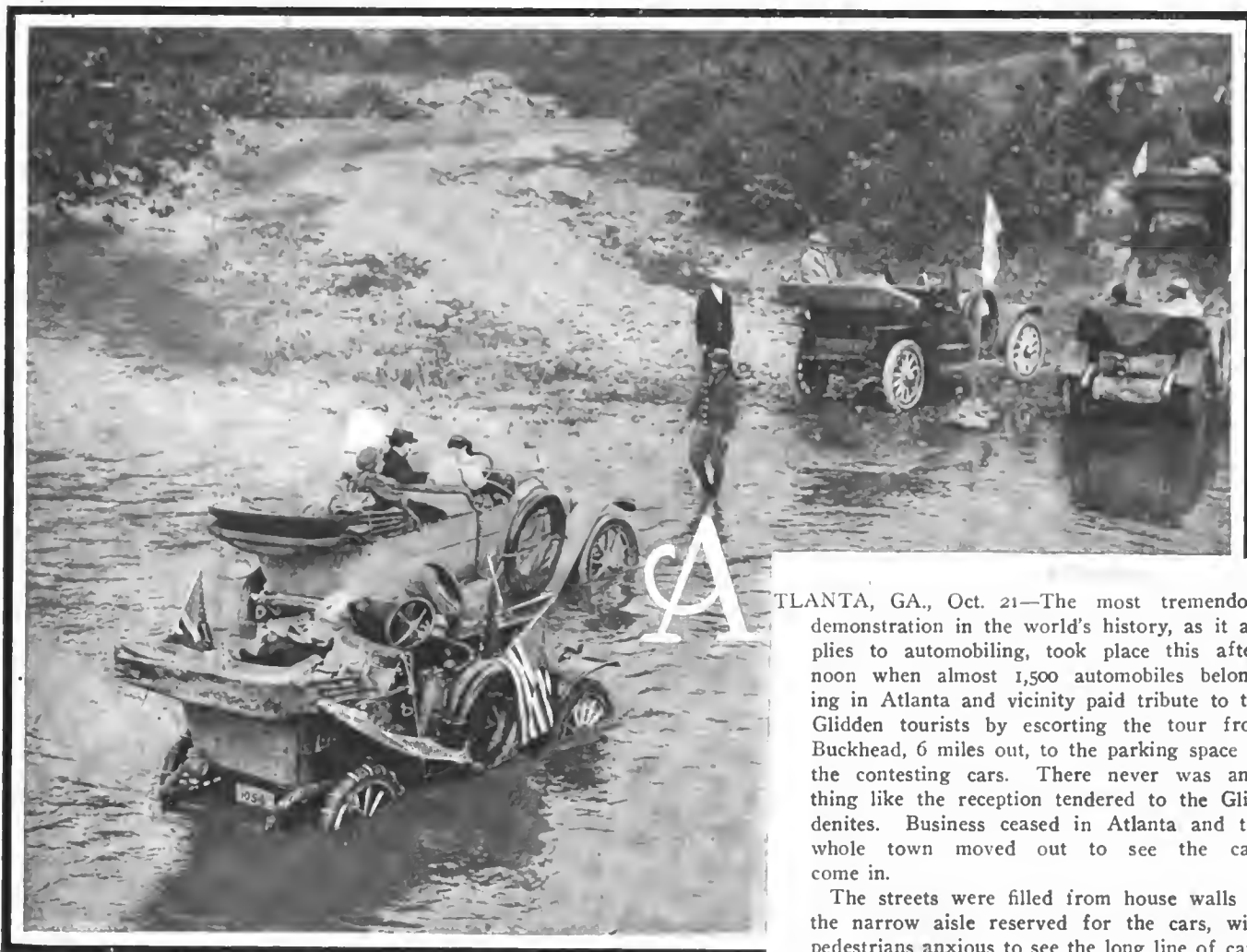

Fig. 5—Part section of Miller muffler

the chambers increase in size as the muffler outlet end is approached, the whirling motion would be continually increased but for the diminished velocity of the gases. The whirling effect is accompanied by a suction created in the chambers which tends to draw the exhaust into the muffler, thereby offsetting, to some extent, the back pressure caused by the same. In the last chamber no central opening is provided so that all the gas finally has to take the path leading along the muffler wall. The Miller muffler is manufactured by the Miller Silencer Company, Captain J. M. Miller, of 25 The Victoria, Washington, D. C.

# THE AUTOMOBILE

## Maxwells Alone Perfect in Glidden



THE FORD OVER BACK CREEK STALLED A SCORE OF CARS

ATLANTA, GA., Oct. 21—The most tremendous demonstration in the world's history, as it applies to automobiling, took place this afternoon when almost 1,500 automobiles belonging in Atlanta and vicinity paid tribute to the Glidden tourists by escorting the tour from Buckhead, 6 miles out, to the parking space of the contesting cars. There never was anything like the reception tendered to the Gliddenites. Business ceased in Atlanta and the whole town moved out to see the cars come in.

The streets were filled from house walls to the narrow aisle reserved for the cars, with pedestrians anxious to see the long line of cars. The Atlanta newspapers devoted their whole front pages to the affair in preparing this city for the advent of the tourists.

It was a magnificent sight down Peachtree street with the Glidden cars moving sedately between solid masses of cheering citizens. On the other hand it was cruelly hard upon the cars themselves. They had just finished a long run in warm weather like July in New York, and many of them were short of water when they checked in. The course was long, and naturally the cars had to proceed at a slow rate with frequent stops and starts. The immediate result was that several of the contesting cars seized pistons and experienced overheating during the parade. The final results are problematical, but it is reasonably certain that several of the clean-score cars will suffer from the parade when they get into the deep Florida sands that are promised for Wednesday and Thursday.

The roads to-day were only fair. In South Carolina and in Georgia, on both sides of Commerce, the highway is largely unimproved, save for considerable grading. The schedule was not hard and only six cars suffered penalties. The chief of these will fall upon Oldsmobile No. 60, which broke its steering yoke and right front spindle north of Commerce. The car had just crossed a bridge and plunged into a chuck-hole. In trying to extricate it, the steering gear gave way. Case car 71 suffered much



The Tarrytown Maxwell team, which was the only trio that had reached Atlanta without being penalized

tire trouble all day and was not reported to-night. Oldsmobile 65 lost its clean score to-day, being delayed 17 minutes by tire trouble. The other penalizations were inconsequential.

It was a hard day on tires from start to finish, owing to the loose surface and lack of traction in numerous spots.

The Maxwell Tarrytown team retained its lead with a clean score for all cars composing it. Save for some minor adjustments that will be made on Tuesday's running time all the cars finished the day in just as good apparent condition as when they left New York. Just how much they were affected by the

TABLE SHOWING EQUIPMENT AND PENALIZATION OF CONTESTING CARS IN GLIDDEN TOUR.

Team.	Number.	Car.	Magneto.	Carbureter.	Tires.	Sizes.	Penalization.
Tarrytown.....	1	Maxwell	Splitdorf	Stromberg	Ajax	35x4 1/2	0
	2	Maxwell	Splitdorf	Stromberg	Ajax	35x4 1/2	0
	3	Maxwell	Splitdorf	Stromberg	Ajax	35x4 1/2	0
Atlanta 2.....	11	Stevens-Duryea	Bosch	Stevens-Duryea	Diamond	36x4 1/2	0
	39	Stevens-Duryea	Bosch	Stevens-Duryea	Goodrich	36x4 1/2	0
	66	Stevens-Duryea	Bosch	Stevens-Duryea	Fisk	36x4 1/2	19
Jacksonville.....	32	Cadillac	Delco System	Cadillac	Morgan & Wright	37x4 1/2	0
	40	Cadillac	Delco System	Cadillac	U. S.	37x4 1/2	0
	47	Cadillac	Delco System	Cadillac	Morgan & Wright	36x4	23
Atlanta 3.....	43	Ford	Ford	Kingston	Fisk	30x3 front-30x3 1/2 rear	125
	44	Ford	Ford	Kingston	Firestone	30x3 front-30x3 1/2 rear	0
	45	Ford	Ford	Holley	Fisk	30x3 front-30x3 1/2 rear	0
Florida.....	28	Cadillac	Delco System	Cadillac	U. S.	37x4 1/2	4
	29	Cadillac	Delco System	Cadillac	U. S.	37x4 1/2	226
	37	Cadillac	Delco System	Cadillac	Hartford	37x4	14
Live Oak, Fla.....	31	Cadillac	Delco System	Cadillac	Morgan & Wright	37x4 1/2	249
	51	Cadillac	Delco System	Cadillac	Morgan & Wright	37x4 1/2	13
	74	Cadillac	Delco System	Cadillac	U. S.	36x4	3
Atlanta 1.....	8	Flanders	Splitdorf	E.M.F. Flanders	Firestone	30x3 front-30x3 1/2 rear	296
	63	Flanders	Splitdorf	E.M.F. Flanders	Firestone	30x3 front-30x3 1/2 rear	104
	61	Flanders	Splitdorf	E.M.F. Flanders	Firestone	30x3 front-30x3 1/2 rear	5
Nashville.....	56	Marathon	Remy	Schebler	Goodrich	34x3 1/2	225
	57	Marathon	Remy	Schebler	Goodrich	34x3 1/2	210
	58	Marathon	Remy	Schebler	Goodrich	34x3 1/2	43
Detroit, Mich.....	53	Flanders	Splitdorf	E.M.F.	Firestone	30x3 front-30x3 1/2 rear	612
	54	Flanders	Splitdorf	E.M.F.	Firestone	30x3 front-30x3 1/2 rear	0
	55	Flanders	Splitdorf	E.M.F.	Firestone	30x3 front-30x3 1/2 rear	416
Georgia-Dixie.....	4	Maxwell	Splitdorf	Stromberg	Ajax	35x4 1/2	0
	49	Columbia	Bosch	Columbia	Diamond	35x4 1/2	0
	50	Maxwell	Bosch	Stromberg	Ajax	34x4	1000 (Non-Con.)
Atlanta Journal.....	5	American	Bosch	Stromberg	Fisk	40x4	0
	6	Thomas	Bosch	Mayer	Goodyear	36x4 1/2	1000 withdrawn
	7	White	Bosch	White	Goodrich	34x4	27
Cordelc, Ga.....	60	Oldsmobile	Bosch	Nelson	Goodrich	34x3 1/2	1150
	65	Oldsmobile	Bosch	Nelson	Firestone	39x5	17
	69	Oldsmobile	Bosch	Nelson	Diamond	38x4 1/2	1
Everglades.....	33	Cole	Bosch	Cole	Firestone	34x4	181
	46	White	Bosch	White	Diamond	34x4	1050 withdrawn
	48	Cadillac	Delco System	Cadillac	Morgan & Wright	36x4	0
Albany, Ga.....	34	Halladay	Bosch	Schebler	Fisk	36x4	63
	35	Halladay	Bosch	Schebler	Fisk	36x4	228
	36	Halladay	Bosch	Schebler	Fisk	36x4	1031 (Non-Con.)
Waltham, Mass.....	15	Metz	Bosch	Holley	Goodrich	30x3	160
	16	Metz	Bosch	Holley	Goodrich	30x3	385
	17	Metz	Bosch	Holley	Goodrich	30x3	1000 withdrawn
Atlanta 6.....	18	Garford	Bosch	Garford	Goodyear	36x4 front-36x4 1/2 rear	970
	19	Mitchell	Splitdorf	Holley	Morgan & Wright	36x4 1/2	0
	20	Schacht	Mea	Schebler	Goodyear	34x4	1000 (Non-Con.)
Atlanta 4.....	10	Pierce-Arrow	Bosch	Pierce-Arrow	Goodyear	36x4 1/2	26
	12	Marmon	Bosch	Schebler	Fisk	36x4	1000 withdrawn
	64	Pierce-Arrow	Bosch	Pierce-Arrow	Fisk and Diamond	37x5 front-36x4 1/2 rear	1108 withdrawn
Atlanta 7.....	21	Corbin	U. & H.	Schebler	Morgan & Wright	34x4	23
	14	White	Bosch	White	Diamond	32x4	2133 (Non-Contestant)
	22	Thomas	Bosch	Mayer	Goodyear	38x5 1/2	0
Un teamed Cars.....	26	Mitchell	Splitdorf	Holley	Kelly-Racine	33x4	18
	27	Chalmers	Bosch	Rayfield	Goodrich	35x4	13
	41	Winton	Bosch	Stromberg	Goodrich	37x5	54
	42	E.M.F.	Splitdorf	E.M.F.	Morgan & Wright	33x4	2164 withdrawna
	52	Paekard	Bosch	Paekard	Swinehart	34x4	14
	59	Cadillac	Bosch	Cadillac	Goodyear	36x4	146
	70	Krit	Bosch	Stromberg	Goodrich	32x3	45
71	Case	Remy	Stromberg	Firestone	34x4	429	
73	Mitchell	.....	.....	.....	.....	0	
72	Haynes	Eiseman	Stromberg	Goodyear	36x4	728	

‡Not reported at Atlanta night control.



The long line of cars stopped at Lexington, Va., to allow the tourists to inspect Washington and Lee College

parade through Atlanta remains for the Florida sands to tell. The Stevens team and the Cadillac team added nothing to their demerits and the Fords maintained their status. The Oldsmobile team is out of the running, although it is likely that all three cars will finish the tour.

Aside from the Maxwell factory team, the other clean scores are the following: Maxwell 4, American 5, Stevens 11, Mitchell 19, Thomas 22, Cadillac 32, Stevens 39, Cadillac 40, Ford 44, Ford 45, Cadillac 48, Columbia 49, Flanders 54, Mitchell 73.

Atlanta is taking more than a curious interest in the tour and the tourists. Upon arrival at headquarters in the Georgian Terrace Hotel, a magnificent new hostelry, the members of the tour were presented with engraved invitations from nine of the chief social and professional organizations of the city to make themselves at home in the various club quarters.

There was a dinner to-night at the Piedmont Club and on Monday there will be a barbecue and theater party, beside quite a number of less formal entertainments.

It has been estimated so far that the souvenirs, such as toilet accessories, cold-cream, tobacco and other small articles that have been heaped upon the tourists along the route, cost their purchasers not less than \$2,000. They have been of real use. For instance, before reaching Charlotte a package was handed to each member of the tour containing toilet soap, talcum powder, toilet water and tooth-paste, all the gift of the local Y. M. C. A. Equally appropriate were a number of the other gifts.

After the fierce runs of mid-week, the last two days have been rather easy and quite monotonous.

One feature of the tour which is attracting deserved favorable comment is the work of the official cars. The Reo pilot cars have performed their work in a manner that leaves nothing to be desired, while the Cunningham pacemaker has met the severe test imposed upon it without flinching. Even the Chalmers press car, handicapped as it is with many pounds of over-fed newspaper men, has finished each day's run well up ahead of the line.

The trio of baggage trucks—Marathon, Reo and Federal—are seldom far behind when the night control is reached.

### 60 Miles Through the Night

WINSTON-SALEM, Oct. 18.—Yesterday's wild race from Natural Bridge to Roanoke over seething roads and through a deluge of driven rain was discounted in its spectacular features by the night ride at top speed that featured to-day's run. Definite penalties were charged against 23 contesting cars, while seven failed to put in an appearance at night control up to the time the official report was made up.

The deluge of yesterday was so great that it was doubtful whether the cars would start at all during the day, but about 10 o'clock the word was given that the cars would be allowed to proceed as far as Rocky Mount without being checked out until arrival at that place. The difficulty lay in the condition of Back Creek, five miles from Roanoke, which was swollen to flood size. The cars forded this stream on their own power in large measure, but about twenty of them were stalled in midstream through the short-circuiting of magnetos and the flooding of carbureters. The column finally reached Rocky Mount around 4 o'clock and it was discovered that the checking out station had been moved along about 9 miles. The route up into the Blue Ridge was wonderfully beautiful everywhere except under the wheels of the cars. The hills were steep over Lynville Mountain and beyond, and except for short stretches the road was so bad that the cars barely crawled. The checking out station was 40 miles from Roanoke and 20 miles north of Martinsville, where noon-control was to have been established. Those 20 miles added the finishing touches to the majority of the clean scores, for they were all but impassable on account of the slippery going. Martinsville was reached just as night was falling. One by one the big blazing stars came out and the shadows from the wild woods swallowed up the moonless road.



New six-cylinder Chalmers press car



The Reo baggage truck performed splendidly



# Bridgeless Peck Creek, Which Was Swollen by the



1—At the top of the ridge, going down toward Peck Creek  
 3—Two cars stalled in the stream at the same time

2—How the radiators were covered to keep out the water  
 4—Maxwell No. 1 started across with a rush and landed safe

# Continued Rains, Gave the Tourists Untold Trouble

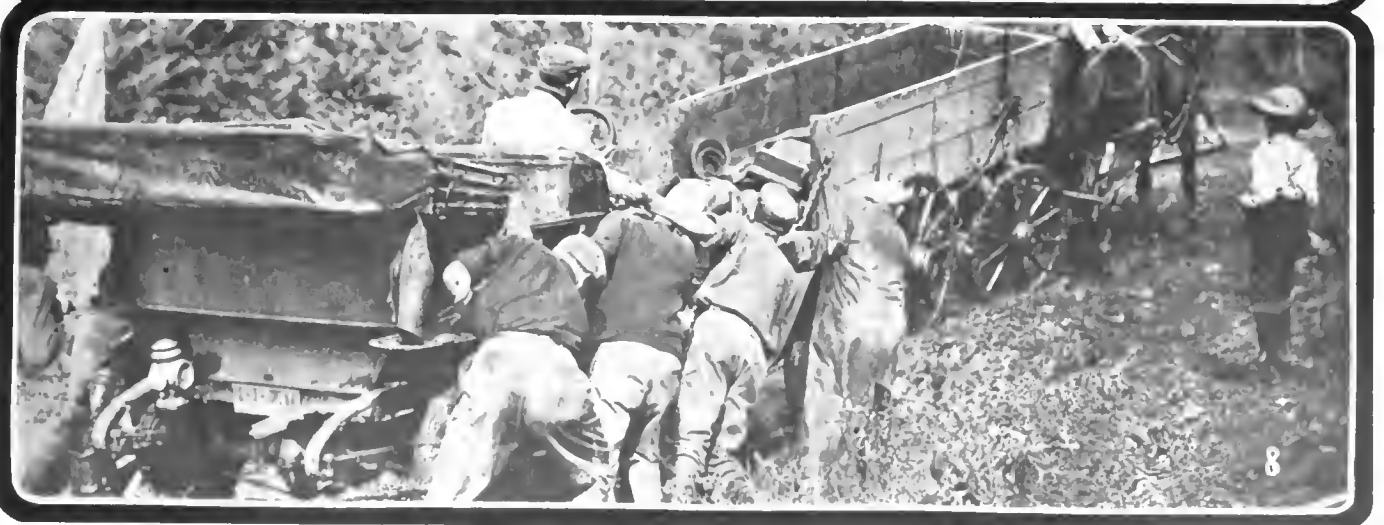

5—Waiting on the hill for their turn to rush the diagonal ford  
 7—The cars that were stuck came out finally under two-mule power

6—V'elie press car caught when only a few feet from the shore  
 8—After getting on the far bank the mule tractor came in handy



*In the above pictures are given a few evidences of the manner in which some sections of the South look after their roads. In the top illustration Krit No. 70 is seen negotiating a particularly bad stretch. There were miles and miles of roads no better than that shown in the middle picture. The conditions outlined in the lower illustration are to be attributed to the excessive rains, the effect of water shown being merely an undrained road hollow, how it impeded the cars is evident from the picture.*

All around the horizon the peaks of the Blue Ridge loomed into the purple night and the breath of the trees supplied the inspiration for the marvelous run that followed into Winston-Salem. Sixty miles to the South lay the North Carolina city that was designated as night control and few of the tourists had ever been over the road in daytime, to say nothing of night.

The majority of the cars had from 2 to 3 hours left on their running schedule when they reached Martinsville and it was certain that scores would be decimated. But among the caravan were many drivers who would not say die and of these there are still a few with perfect scores.

It was a fierce drive over rough dark roads for full 20 miles and then the pike grew better and better until the spellbound passengers realized that they were whirling along at better than 30 miles an hour with grinning death just beyond the radiators. There were a few minor accidents but nothing of much moment, and to the astonishment of many a portion of the Glidden caravan finally reached control. There is a saying that the Lord is good to Glidden tourists and the members of the present run are willing to subscribe to that sentiment.

Despite the lateness of the hour, the whole city of Winston-Salem was out to welcome the travelers. Two bands played industriously and inside official headquarters at the Hotel Zinzendorf a galaxy of feminine beauty was gathered to personally welcome each new arrival. The drivers and in fact many of the passengers were treated as if they were heroes returning from a winning battle. At midnight Governor Smith made an address in which he voiced his well-known sentiment: "To Hades with the tariff; give us good country schools and good roads."

Some idea of the hardships encountered by the tourists to-day may be had from the statement that Governor Mann, who evidently knew what was ahead, side-stepped the tour through his State. If he had been within earshot of some of the tourists at the end of the day he would have in all probability registered a vow to get busy on good roads work at once. It is doubtful if the spectacle of 80 automobiles being dragged through muddy streams with the aid of Virginia mules will have a beneficial effect upon automobilists who contemplate traveling southward in the near future. Even the rickety old foot-bridge that was swung across Back Creek, where the cars were compelled to cross a diagonal ford, was in sympathy with the occasion, for while a crowd of automobilists were strung across it watching the passage of the cars through the turbid yellow waters, the flimsy structure emitted several warning cracks, and there was a lively stampede for either shore, according to which was nearer. Two men went through the rotten wood, but were grabbed by those nearest them and hauled up onto the bridge again. The passage of the ford by the 80 cars occupied at least five hours, and after getting through the contestants were compelled to negotiate 50 miles of as poor roads as can be found in these United States.

Nos. 6, 8, 17, 20, 42, 50 and 53 did not report at night control before midnight. Among the penalizations were: No. 7, 18 points; No. 10, 12; No. 14, 152 (making total of 1,133); No. 15, 130; No. 16, 57; No. 18, 10 (making total of 970); No. 21, 23; No. 26, 81; No. 31, 249; No. 33, 13 (making total of 100); No. 35, 228; No. 37, 3; No. 41, 33 (making total of 54); No. 46, 42 (making total of 46); No. 56, 153; No. 58, 34 (making total of 43); No. 59, 60 (making total of 65); No. 60, 81 (making total of 85); No. 63, 104; No. 64, 104; No. 66, 9 (making total of 19); No. 71, 117 (making total of 412).

### Maxwells Assume Lead

CHARLOTTE, N. C., Oct. 19.—The trip from Winston-Salem to Charlotte, N. C., proved to be the most pleasant so far from a weather point of view. The start from the busy manufacturing center of Winston-Salem was most auspicious and it was seen by at least 1,000 college and school-girls who lined the sidewalks to witness the performance. The roads generally proved to be excellent as far as High Point, which by the way

is a manufacturing center for furniture rivalling Grand Rapids. But when the Davidson County line was reached there was a different road story to tell. Davidson County is located in a rich cotton growing belt and is quite a distributing and collecting point for that staple, but its roads are neglected. Most of the penalizations that accrued to-day resulted from the bad condition of the highway near Lexington. North of Salisbury where the road passes out of Davidson county there is a startling change for the better, and from Salisbury to Charlotte the roads are fair to good, with some short stretches that rival anything in New York state.

The contest narrowed down sharply after Winston-Salem and the Maxwell factory team showed out in front with a clear lead in the race for the Glidden Trophy. All the cars, Nos. 1, 2 and 3, have clean scores, the team being the only one left in that category. Next in order comes the Stevens-Duryea team, consisting of cars 11, 39 and 66. The latter is demerited 19 points and the other two are clean. The Jacksonville Cadillac team is third with 23 demerits. This team consists of numbers 32, 40 and 47. The Oldsmobile team is fourth and the Ford team fifth. The others are so far out of it that they are not considered to have a chance.

The Metz team was heavily penalized for the run into Winston-Salem, one car breaking a wheel and suffering other injuries so severe as to necessitate its withdrawal. Both of the other members were late getting in and the team is out of the running. E-M-F 42 has withdrawn as the result of another broken axle. This car was equipped with a new kind of solid tires that did not lend themselves to touring over mountain roads. The only difficulty experienced by the car was due to the jolting of the solid tires.

The route of the tour carries the column through a series of receptions that are hearty and hospitable to a degree. At Charlotte open house was held at the Manufacturers' Club and at Salisbury the civic organizations did everything possible to make the noon stop pleasant.

To-day the town boosters were scattered all along the route, and each contingent seemed to be exerting itself to outdo the others in pressing gifts upon the travelers. Pipes and tobacco were furnished by one Winston-Salem firm. Other firms gave soap and vanity mirrors—these latter for the ladies only, of course—buttons, badges, flags, illustrated booklets, and other articles designed to extol the merits of their several towns. Many of the villages through which the tour passed had welcoming banners stretched across the roadway, each inscribed with hearty greeting. To-day's experience was a welcome one after the hardships encountered on yesterday's mud plug.

Nos. 16 and 72 had not reported at midnight. Penalties inflicted to-day included: No. 10, 14; No. 14, 1,000 (out); No. 15, 24 (making total of 154); No. 19, 21; No. 33, 62; No. 37, 11 (making total of 14); No. 53, 21 (making total of 612); No. 59, 58 (making total of 123); No. 60, 26 (making total of 111); No. 70, 45.

### Seventh Day Uneventful

ANDERSON, S. C., Oct. 20.—The seventh day of the tour ended in the center of the cotton belt of the southeast. It is said that the territory tributary to Anderson raises a bale per capita for its population and that the giant mills use something over 30,000 bales more than the territory produces. The run was uneventful and the scenery did not possess the wild charm of the Virginia mountains, but the roads were excellent nearly all the way.

Like nearly all the towns used for night controls so far, the hotel accommodations for such a large party were inadequate. They were all right as far as they went, but did not extend any noticeable distance.

The Maxwell team maintained its lead and neither of the two teams nearest the front received any demerits. The Oldsmobile team, however, fell back a little and is now behind the Fords.

South Carolina furnished a pleasant surprise to the tourists



The above illustrations will give some indication of the hardships encountered by the contestants on the Glidden tour. In the upper picture is shown the Flanders No. 63 stuck in a 12-foot sandy rut, necessitating hard work on the part of the whole crew in order to extricate it. Rain persisted for nearly a week and every depression in the road formed a miniature lake. Nearing Atlanta the tourists encountered some excellent roads which were kept in shape by gangs of convicts.



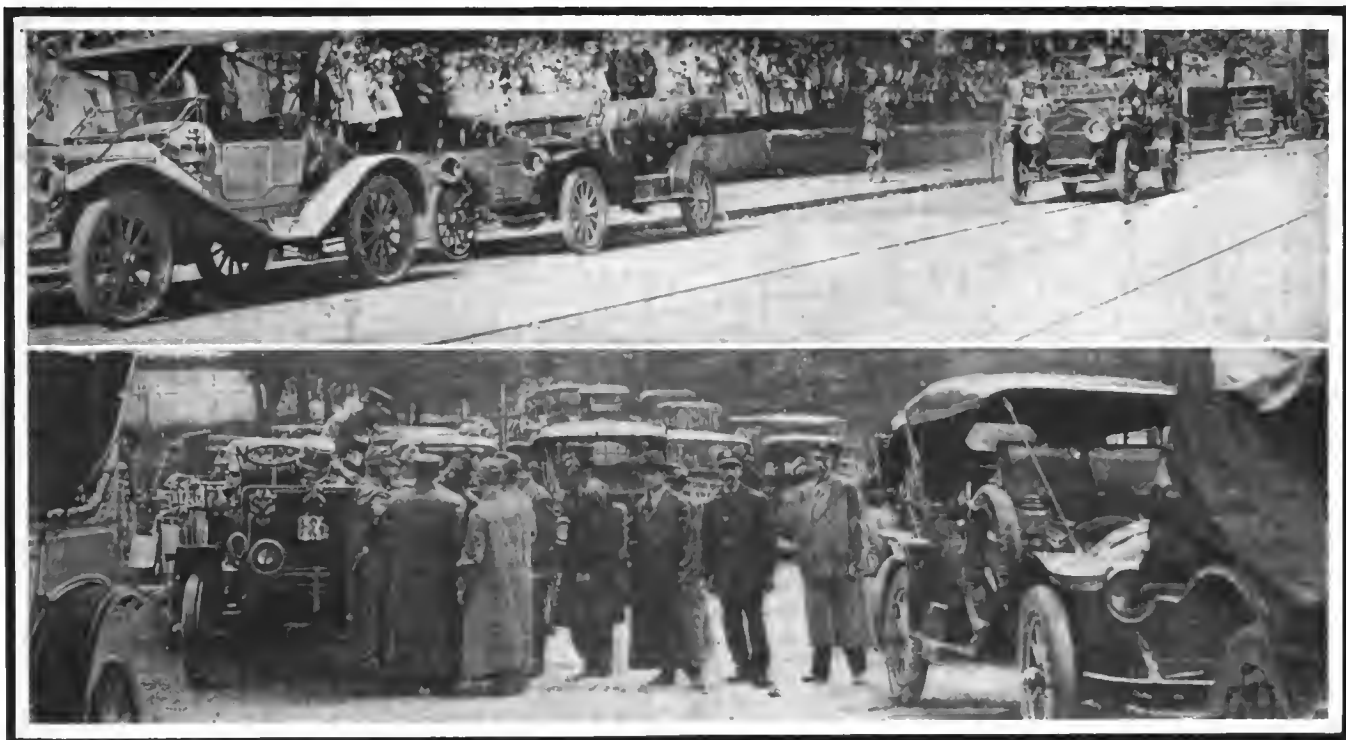

Crowds of school children welcomed the Gliddenites on their arrival at Roanoke  
The fire department at Natural Bridge, Va., is the proud possessor of a motor hose wagon, which came out to welcome the travelers

in the matter of roads. They had been led to expect that this state was far behind North Carolina in that respect. But the run of 160 miles from Charlotte to this place was over the finest dirt and macadam roads that have yet been encountered below Mason & Dixon's line. A couple of spills were the only features of the day's run. These were due to the speeding proclivities of a couple of Atlantans, who were evidently so tickled at getting on good roads once more that they could not help whooping things up a little. Anderson will never get far on its ability to take care of transient travelers, the accommodations here being so meager that in not a few instances a half dozen men were compelled to bunk together in one crowded compartment, which contained little or no facilities for removing the stains of travel.

At midnight to-night Nos. 15 and 16 had failed to report. Among the penalized cars were: No. 7, which accumulated 9 demerits; No. 60, 39, and No. 71, 8.

### From Atlanta to Cordele

CORDELE, GA., Oct. 24—The run to-day from Atlanta was over astonishingly good roads that have been built within the past year to a very large extent. For most of the distance of 167 miles the cars traveled over highways that seemed almost like boulevards when compared with the fairly good roads of the latter part of last week. Georgia is evidently alive to the value of good roads, and has accomplished a vast amount of work along these lines since the vogue of the automobile in the South.

When the cars reached Macon, 100 miles south of Atlanta by the national highway route, which was scheduled for the noon stop, the town was in holiday dress, and the streets were lined with thousands of citizens cheering the tourists as they entered the city.

One section of road encountered to-day attracted no end of favorable comment. Leaving Macon the tourists encountered 15 miles of broad macadam road leading across low, swampy ground, that under ordinary conditions, before the road was built, would have tested the cars to their utmost. This stretch of road is broad enough for four cars traveling abreast.

Case car No. 71, which reported so late at Atlanta Saturday night that it failed to get on the official report blanks and was ruled out unofficially, was back in the run to-day and received the only penalization imposed. It was nine minutes late getting into Macon.

Pierce-Arrow No. 64, owned by E. Rivers, of Atlanta, was withdrawn by its owner who contracted a heavy cold



Where the cars were parked overnight at Staunton, Va.



during the rains of last week and on the advice of his physician abandoned the run.

White gasoline car No. 46, owned by Julian Howard of Jacksonville, failed to arrive here at midnight. Report has it that it is ditched somewhere near Barnesville, Ga., with a broken axle. Those in charge of the car have wired that they will be able to effect repairs in time to join the tour to-morrow.

What looked like an ugly accident occurred just before Macon was reached when Cadillac car No. 47 went over a railroad right-of-way into a 6-foot ditch. It was pulled out by a non-contestant and made the noon control all right.

Considering its size, Griffin, Ga., accorded the tour one of the heartiest receptions given it along the route. Such was the opinion of the tourists, at least; but their minds were disabused later on when they discovered that the uproar in the streets of the small town was due to the fact that a wandering circus had pitched its tents there for the day and thousands of people from the surrounding country had poured into the town to witness the parade preceding the performance. It is quite possible that the Griffinites were unaware of the passage of the Gliddenites till their arrival. During the afternoon the travelers were greatly entertained by witnessing the operation of manufacturing turpentine at one of the roadside camps.

One of the contestants in the tour, Capt. W. J. Hillman, of Live Oak, Fla., who is engaged in the turpentine business, gave an impromptu lecture on the various processes that proved decidedly interesting.



Checking in at the noon control at Salisbury, S. C.

This city to-night is ablaze with electric lights specially strung to celebrate the honor accorded Cordele by placing it on the itinerary as an over-night stop. All the leading clubs supplied the tourists with visitors' cards and placed their club houses at the disposal of the visitors.

All told, the participants of the tour feel perfectly content in respect of the welcome they have hitherto met all along their route.

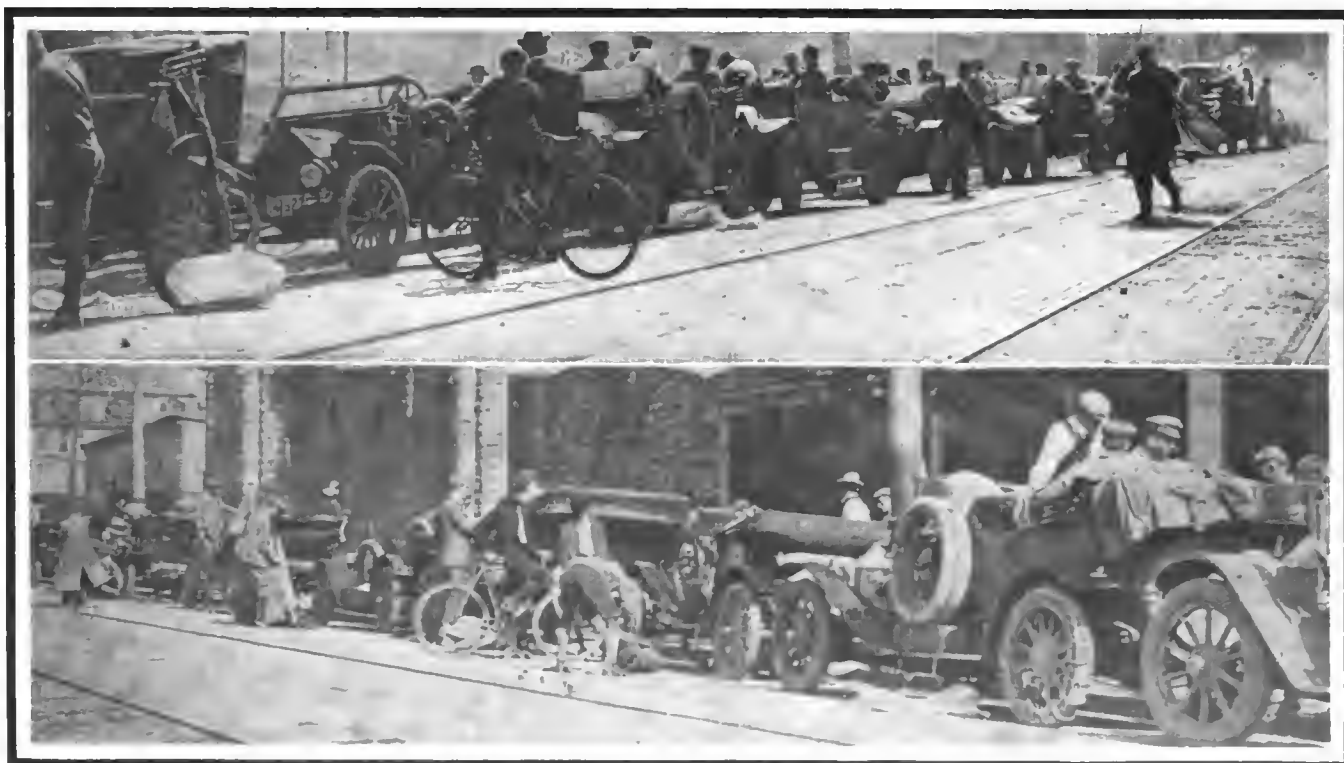

Line-up for the start from Roanoke, Va., on the morning of the fifty day  
Just before the start from Winston-Salem, N. C., on the morning of the sixth day

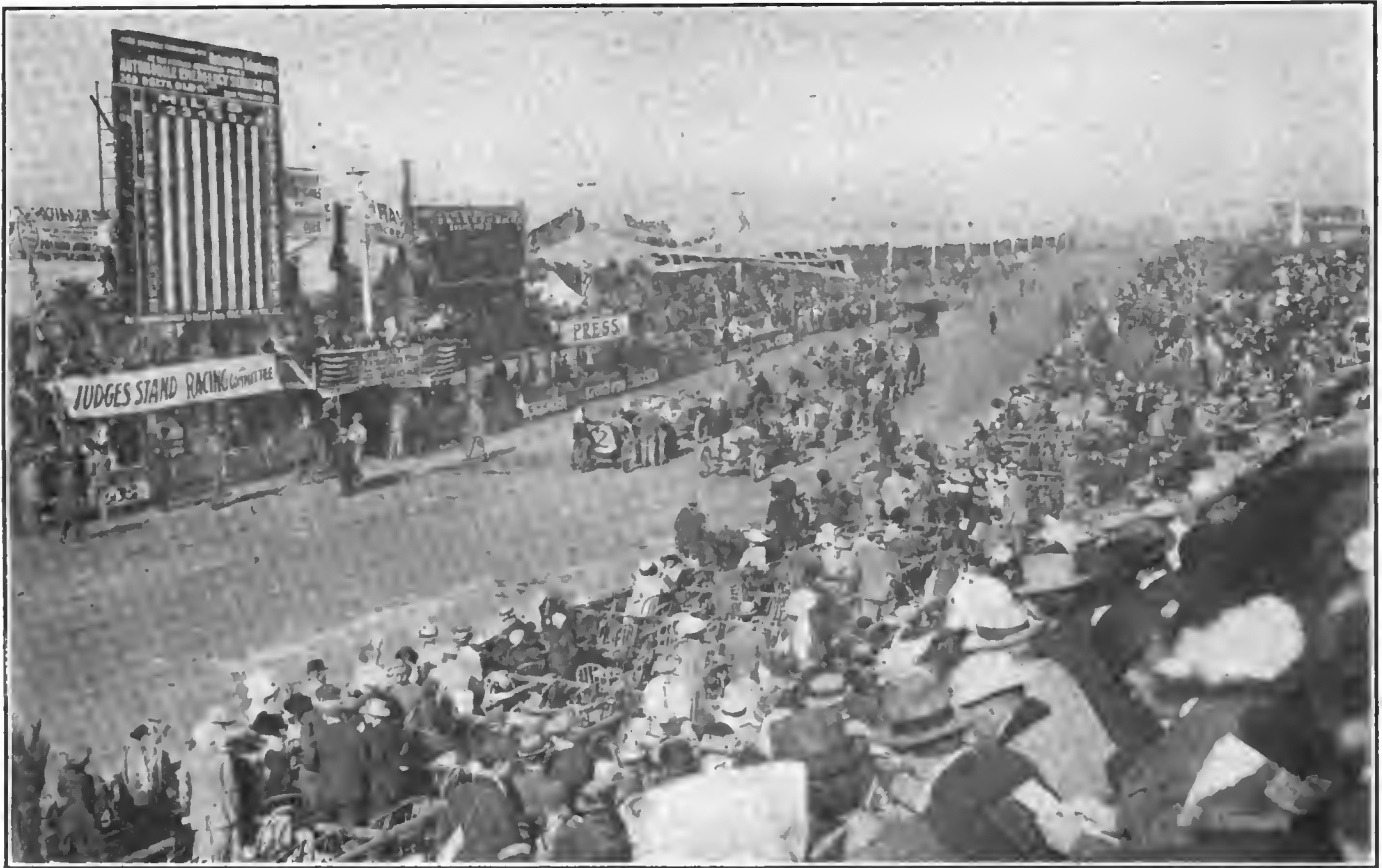

Line-up for the medium and heavy car events in the recent Santa Monica races, showing grand stand and timer's pavilion

# Fast Time Marked Los Angeles Meet

**L**OS ANGELES, CAL., Oct. 22—The usual fast time marked the two-day speedway motordrome meet. Five thousand people saw Saturday's sport and 10,000 crowded the piepan to-day. The feature Sunday was the match race between Tetzlaff in a Fiat and Lee Oldfield in a second Fiat. Tetzlaff

won two straight 2-mile heats in 1:18.57, and 1:17.9. These cars also hooked up in the two 5-mile free-for-all events. Tetzlaff won the first in 3:19.25. Oldfield was 4 seconds behind. The Inter-State, with H. Endicott driving, took third. In the second free-for-all Oldfield beat Tetzlaff in 3:20.33. Dingley in the Pope was third.

The 5-mile race for cars under 600 cubic inches piston displacement was easy for Bert Dingley. The Schacht also had an easy time winning the 10-mile 231-300 class, and the 25-mile race for the same class. Tetzlaff and Dingley fought out the free-for-alls Saturday. Both 5-mile races were fights, the Pope finishing a close second each time. Hanshue in the Mercer was an easy winner in the 10 and 25-mile races for his class. Dingley won the handicap, Saturday, and was beaten by Endicott in the Inter-State Sunday. Endicott had 13 seconds in 5 miles. Summaries:



Start of the 301 to 450 class in the recent Santa Monica races

### SATURDAY'S EVENTS

Pos.	Car	Driver	Time
<b>5 Miles, 161 to 230 Class</b>			
1	Regal	Anthony	4:25 1-5
2	Maxwell	Smith	
3	Reo	Endicott	
<b>10 Miles, 231 to 300 Class</b>			
1	Mercer	Hanshue	7:45 1-5
2	Schacht	Jeffkins	
3	Cole	Carlson	
<b>1-Mile Time Trial</b>			
1	National	Herrick	:44 3-5
<b>5-Mile Free-for-All</b>			
1	Fiat	Tetzlaff	3:25 3-5
2	Pope-Hartford	Dingley	
3	Stutz	Lewis	

Pos.	Car	Driver	Time
<b>25 Miles, 231 to 300 Class</b>			
1	Mercer	Hanshue	20:59 1-5
2	Cole	Carlson	
3	Regal	Anthony	
<b>5 Miles, Handicap, Free-for-All</b>			
1	Pope-Hartford	Dingley	3:58 1-5
2	Regal	Anthony	
3	Reo	Endicott	
<b>5 Miles, Free-for-All</b>			
1	Fiat	Tetzlaff	3:33 1-5
2	Pope-Hartford	Dingley	
3	Inter-State	Endicott	
<b>SUNDAY'S EVENTS</b>			
<b>5 Miles, Under 600 Cubic Inches</b>			
1	Pope-Hartford	Dingley	3:40.2
2	Inter-State	Endicott	
3	Stutz	Lewis	
<b>10 Miles, 231 to 300 Class</b>			
1	Schacht	Shain	7:55
2	Cole	Carlson	
3	Regal	Anthony	
<b>10 Miles, 161 to 230 Class</b>			
1	Maxwell	Smith	8:42.41
2	Regal	Anthony	
3	Reo	Endicott	
<b>5 Miles, Free-for-All</b>			
1	Fiat	Tetzlaff	3:19.35
2	Fiat	Oldfield	
3	Inter-State	Endicott	
<b>25 Miles, 231 to 300 Class</b>			
1	Schacht	Shain	19:49.57
2	Cole	Carlson	
3	Regal	Anthony	
<b>5 Miles, Free-for-All</b>			
1	Fiat	Oldfield	3:20.33
2	Fiat	Tetzlaff	
3	Pope-Hartford	Dingley	
<b>5 Miles, Handicap</b>			
1	Inter-State	Endicott	4:02.98
2	Pope-Hartford	Dingley	
3	Regal	Anthony	



Herrick in a National beating world's record in Santa Monica race

### Sealed Handicap at Long Island Club

The Long Island Automobile Club's first contest for the Schimpf Trophy will be held on Saturday, October 28, 1911, starting from the Club House, 920 Union street, at 1 p. m. At the suggestion of the Board of Governors, the first contest will be an easy one, practically a club run, with the award a matter of chance. The restriction in regard to the amateur status of drivers has been eliminated from the deed of gift and any member of the Club in good standing, who drives his own car, is eligible. There will be no restriction as to passengers to be carried by the cars.



Merz in the National at the finish of the 301 to 450 class race at Santa Monica, winning first place and averaging 74.42 miles an hour

REVISED OFFICIAL RECORD OF TRUCKS IN SAN FRANCISCO'S RECENT TWO-DAY TEST

No. of Entrant	Name of Truck	Class	Running Schedule, Miles Per Hour	Price of Truck	Load Carried, Pounds	Gasoline, Gallons Used	Cost at 14 1/2c Per Gallon	Lubricating Oil, Pints Used	Cost at 40c Per Gallon	Drivers' Wages, Two Days	Depreciation 12% Per 300 Days	Total Cost	Total Cost, Per Mile	Total Cost, Per Ton-Mile	Total of Road and Final Technical Examination Penalties	Total Cost Per Ton-Mile, Including Penalties at 1-10c Per Penalty	Hrs. Actual Running Time	Min. Covering Course of Sec. 133 Miles
7	Brush (winner)	1	14	\$450	500	5 3/4	\$0.83 3/4	5	\$0.25	\$4.00	\$0.36	\$5.44 3/4	\$0.0409	\$0.1636	89	\$0.1660	7:41:20	
26	Indian	1	14	450	250	3 3/4	.52 9/16	1	.05	4.00	.36	4.93 9/16	.0371	.2968	None	.2968	7:16:17	
24	Reo (winner)	3	12	875	1,500	12	1.74	11	.55	5.00	.70	7.99	.0600	.0809	86	.0809	8:56:21	
8	Buick	3	12	1150	1,500	15	2.17 1/2	10	.50	5.00	.92	8.59 1/2	.0646	.0861	None	.0861	8:11:53	
1	White	3	12	2400	1,500	10 1/4	1.48 3/4	5 1/2	.27 1/2	5.00	1.92	8.68 1/2	.0652	.0869	None	.0869	6:18:5	
6	Franklin (winner)	4	12	2620	2,000	16	2.32	3 1/3	.16 2/3	6.00	6.00	10.57 2/3	.0795	.0795	4	.0795	6:53:24	
20	Grabowsky	4	12	2430	2,000	16	2.32	11	.55	6.00	1.92	10.79	.0811	.0811	20	.0812	8:34:59	
22	Autocar (winner)	5	10	2400	3,000	13	1.88 3/4	6 1/2	.32 1/2	6.00	1.97	10.13	.0761	.0507	None	.0507	7:59:16	
4	White	5	10	3350	3,000	11	1.59 1/2	9	.45	6.00	2.68	10.75 1/2	.0806	.0537	None	.0537	6:11:5	
3	Federal	5	10	2250	2,000	19 1/4	2.77 5/16	3	.15	6.00	1.80	10.72 5/16	.0806	.0806	550	.0847	7:28:12	
11	Reliance (winner)	8	8	3750	7,000	23 1/2	4.83 3/4	16	.80	8.00	3.00	16.65 3/4	.1252	.0357	14	.0358	11:7:40	
28	Packard	8	6	3850	6,000	21 3/4	3.15 3/4	10 1/2	.52 1/2	8.00	3.08	14.75 3/4	.1109	.0369	None	.0369	11:4:35	
9	White	8	6	4050	6,000	22	3.19	11 1/2	.57 1/2	8.00	2.88	17.05 9/16	.1282	.0427	90	.0429	10:22:19	
21	Kelly	8	6	3500	6,000	29	4.20 1/2	10	.50	8.00	3.80	15.50 1/2	.1165	.0388	6	.0388	10:5:59	
13	Gramm	8	6	3890	6,000	28	4.06	16	.80	8.00	3.11	15.97	.1200	.0400	None	.0400	8:52:33	
18	Pope-Hartford	8	6	3600	6,000	38 3/4	5.60 1/16	11 1/4	.57 1/4	8.00	2.88	17.05 9/16	.1282	.0427	96	.0429	10:22:19	
25	Universal	8	K	Withdrawn														
19	White (winner)	9	6	4500	10,000	18 3/4	2.17 3/4	10	.50	8.00	3.60	14.81 3/4	.1114	.02228	None	.02228	11:57:9	
23	White	9	6	4500	10,000	23 1/2	3.40 3/4	6	.30	8.00	3.60	15.30 3/4	.1150	.0230	None	.0230	11:41:5	
17	Pierce Arrow	9	6	4750	10,000	24 3/4	3.55 3/4	3 7/10	.18 1/2	8.00	3.80	15.53 3/4	.1168	.02336	None	.02336	9:58:36	
14	Speedwell	9	6	3650	8,000	22	3.19	7	.35	8.00	2.92	14.46	.1087	.0271	None	.0271	9:43:38	
10	Lewis	9	6	3850	8,000	30 3/4	4.44 1/16	6	.30	8.00	3.08	15.82 1/16	.1189	.0297	50	.0298	10:25:2	

\* Awarded grand prize as winner of entire contest, its cost per ton mile being the lowest.

Revised Figures Show New Winners in Frisco

SAN FRANCISCO, Oct. 15—Several errors having been found in the official records of last week's two-day motor truck contest in this city, a new and revised statement has just been issued by Walter C. Manuel, the official A. A. A. referee. With the tangle straightened out the position of several trucks in the contest is changed.

In the 1,500-pound division the Reo is declared the winner on its economy record of \$.0809 per ton-mile, with the Buick second at \$.0861 and the White third at \$.0869. The Reo suffered 86 points road penalties while the Buick and White were perfect in this regard.

In the 1-ton class the Franklin won at a cost of \$.0795 per ton-mile, with the Grabowsky second, at \$.0812.

The Autocar is declared winner in the fifth division with a cost per ton-mile of \$.0507 and the White second at \$.0537. A Federal, with 550 points road penalties, is third at \$.0847.

The biggest surprise came in the 5,001- to 7,000-pound class, in which the Reliance is declared the winner with a cost per ton-mile of \$.0358. The Packard is second at \$.0369. The White is third at \$.0376 and the Kelly (originally declared the winner) now comes fourth at \$.0388 per ton-mile. The Gramm is fifth at \$.04 and the Pope-Hartford, which suffered 90 points road penalties, is sixth at \$.0429.

In the big division for cars between 7,001 and 10,000 pounds the White No. 19 is declared the winner. Its cost per ton-mile was \$.0228, a record which also secured for it the Grand Prize.

The White No. 23 was second at \$.0230; the Pierce-Arrow third at \$.02336 and the Speedwell fourth at \$.0271. The Lewis, a California made truck, which suffered 50 points road penalties came in fifth at \$.0298 per ton-mile. The table follows.

Racer Sues for Prize Money

OAKLAND, CAL., Oct. 15—Almost every automobile dealer in Oakland has been joined in the suit brought by Earl de Vore, a racing driver, who wants prize money that failed to materialize after the race was won and the shouting over.

De Vore claims he was urged by the Oakland Dealers' Association to enter the contest. He drove a Pope-Hartford and won his race. When he claimed the \$200 prize, however, no money was forthcoming. Now, besides suing the association, he has entered claim against every one of the dealers who are members of the organization.

Fatal Accident Mars Races at Sioux City

SIoux CITY, IA., Oct. 23—"Billy" Pearce, the well-known driver, was killed when his Colby car dashed through the fence, on a trial run on the Sioux City track, the day before the races. Thursday afternoon Pearce was trying out the track, and made the first mile in 1:01. He was increasing his speed, and it is said that he attempted to make a "hairpin" turn, on the first curve from the grandstand, running close to the outside fence, and turning square. The car swerved and dashed through the inside fence. The machine was not badly injured.

Pearce had made fast time on this track the year before, and among other trophies, his Fal car captured the G. & J. trophy at the Indianapolis races in 1909. At the Omaha races two weeks ago he carried off practically all the honors with his Colby car.

On account of Pearce's death, one race, a ten-mile race for cars of Class B-3 B, was called off. Summary:

25-Mile Race, for Stock Cars			
Pos.	Car	Driver	Time
1	Buick	John Sparling	25:27
2	Paige-Detroit	J. W. Shrunk	
3	Chalmers	H. A. Wetmore	
4	Moon	Philip Wells	
5	Reo	Walter Gnehm	
6	Ford	Jim Ralston	

Australian Pursuit Race for Class D Cars			
Won by Buick, driven by Sparling; the Moon, Wells, second.			
10-Mile Event for Class C-2 C			
Pos.	Car	Driver	Time
1	Paige	Shrunk	10:12
2	Reo	Gnehm	
3	Ford	Ralston	
4	Chalmers	Wetmore	

10 Miles for Class B-4 B Stock Cars			
Pos.	Car	Driver	Time
1	Buick	Sparling	10:42
2	Jackson	Harry Woodruff	
3	Cutting	Delaney	

The 50-mile race was the big event the second day. The Buick led for some distance, but was stopped by officials to change tires. The Paige then led but was also compelled to stop. Summary:

50-Mile Free-for-All			
Pos.	Car	Driver	Time
1	Chalmers	Wetmore	55:57
2	Abbott-Detroit	Marvel	
3	Buick	Sparling	
4	Paige	Shrunk	

Class C-2 C, 10 Miles			
Pos.	Car	Driver	Time
1	Paige	Shrunk	11:04
2	Chalmers	Wetmore	
	Ford	Ralston	

Class C-4 C, 10 Miles			
Pos.	Car	Driver	Time
1	Buick	Sparling	10:17
2	Jackson	Young	
3	Moon	Wells	

# How New York Will Regulate Garages

## Text of Proposed Ordinance Which Is Under Discussion

### CHAPTER XXI

**DEFINITION**—By the term garage is meant a building, shed or enclosure, or any portion thereof, in which a motor vehicle is kept, housed or stored.

Sec. 1. It shall be unlawful for any person to store, house or keep within the City of New York any motor vehicle containing volatile inflammable oil except in a building, shed or enclosure for which a garage permit has been issued by the Fire Commissioner.

Sec. 2. An application for a garage permit shall give in detail the following information:

- (a) Name of applicant.
- (b) Location of premises.
- (c) Nature of construction of building.
- (d) Description and maximum number of motor vehicles to be stored therein.
- (e) Maximum quantity of volatile inflammable oils to be stored or kept at one time.
- (f) Maximum quantity of calcium carbide to be stored or kept therein at one time.

Sec. 3. When an application is made for a garage permit wherein more than one motor vehicle is to be stored, housed or kept, or where volatile inflammable oil is to be stored or kept, the application must be accompanied with a detailed plan of the premises, drawn to a scale of not less than one-fourth of an inch to the foot.

Sec. 4. No garage permit to store more than one motor vehicle, or for the storage of any volatile inflammable oil, shall be issued for any building:

- (a) Which is situated within fifty feet of the nearest wall of any building occupied as a school, theater, or other place of public amusement or assembly.
- (b) Which is occupied wholly or in part as a tenement house, hotel, workshop or factory.
- (c) Which is a frame or wooden building.
- (d) Which is not lighted solely by electricity.
- (e) Where drugs, cigars, cigarettes or tobaccos are kept for sale.
- (f) Where paints, varnishes or lacquers are manufactured, stored or kept.
- (g) Where dry goods of any kind or other materials of a highly combustible nature are manufactured, stored or kept.
- (h) Where matches, rosin, turpentine, hemp, cotton, guncotton, smokeless powder, blasting powder, or any other explosives are stored or kept.

Sec. 5. The application and plan mentioned in sections 2 and 3 of this chapter shall be referred to the Municipal Explosives Commission; and upon the recommendation of said Commission the Fire Commissioner may issue a permit.

Sec. 6. A permit may be issued for a garage on premises on which there is a dwelling occupied by the applicant or by his employee, provided that the entrance to the living apartments shall not be through the garage; and provided further that not more than three motor vehicles may be kept or stored in such garage, and that none of them shall be let out for hire.

Sec. 7. A permit may be issued for a garage in a building occupied as a dwelling by either the applicant and one other tenant or by the applicant's employee and one other tenant, provided that not more than two floors or stories above said garage shall be occupied or used as living apartments, such floors being separated from the garage by unplastered fire-proof walls and floors; and provided further that not more than four motor vehicles may be stored in such garage and that none of them shall be let out for hire.

Sec. 8. No volatile inflammable oil except that contained in the motor vehicles may be stored in any garage for which a permit has been issued under sections 6 and 7 of this chapter, unless the building in which such garage is situated is of fireproof construction throughout.

Sec. 9. All garages wherein volatile inflammable oils are stored shall be continuously under the care and supervision of one or more persons each holding a certificate of fitness as a superintendent or manager of a garage. The number of persons required to hold certificates of fitness in each case shall be determined by the Fire Commissioner and shall be stated in the permit.

Sec. 10. No garage permit authorizing the storage of volatile inflammable oils shall be issued for any premises which are not equipped with an oil separator, trap or other contrivance attached to the house drain for the purpose of preventing volatile inflammable oils from flowing into the sewer.

Sec. 11. No garage permit authorizing the storage of volatile inflammable oils shall be issued for any premises which are not equipped with a tank or tanks of sufficient capacity for the storage of such oils except as otherwise provided in this chapter.

Sec. 12. No garage permit authorizing the storage of volatile inflammable oils shall be issued for any premises which are not equipped with one or more portable tanks for the transfer of such oils from the storage tank to the motor vehicles. The number of such portable tanks shall in each case be determined by the Fire Commissioner and stated in the permit.

Sec. 13. No garage permit authorizing the storage of volatile inflammable oils shall be issued for any premises which are not equipped with a pump or other apparatus for drawing off such oils from the storage tank.

Sec. 14. No storage tank, portable tank, oil separator, pump or other apparatus shall be installed in a garage unless a certificate of approval for the same shall have been issued by the Fire Commissioner.

Sec. 15. Applications for certificates of approval for any of the articles

*The new garage law adopted by New York City tersely defines the status of the garage and limits quantity of inflammable oils and other chemicals that may be stored. Permits issued for special garage locations. Fire Commissioner's certificate necessary for storage tanks. Minute details on gasoline handling. Repair shops to be regulated. Storage and sale of kerosene oil arranged for. Signs prohibiting smoking must be displayed.*

mentioned in the preceding section shall be made to the Fire Commissioner, and shall have attached thereto complete working drawings for such articles.

Sec. 16. Each storage tank shall be constructed of steel at least one-quarter of an inch in thickness; shall have a capacity of not more than two hundred and seventy-five gallons, and shall, under test, stand a hydrostatic pressure of at least two hundred and fifty pounds to the square inch.

Sec. 17. Each storage tank shall be coated on the outside with tar or other rust-resisting material, and shall be embedded in and surrounded by at least twenty-four inches of clean sharp sand, well stamped into place.

Sec. 18. Each storage tank shall be so set that the top or highest point thereof shall be at least four feet below the level of the lowest cellar floor of any building within a radius of twenty-five feet from the tank.

Sec. 19. No storage tank shall be placed under the sidewalk or under the front area of any garage.

equipped with a filling pipe, a drawing-off pipe and a vent pipe; provided, however, that no storage tank installed in a garage as a part of an hydraulic storage system shall be required to have a vent pipe. All pipes shall be of galvanized wrought iron and shall have malleable iron fittings. All screw joints must be made with litharge and glycerine.

Sec. 21. The filling pipe must be at least two inches in diameter, and shall be laid at a descending grade from the sidewalks in front of the garage to the tank.

Sec. 22. The intake of the filling pipe shall be located in a heavy cast-iron box, which shall be sunk flush with the sidewalk at the curb level and fitted with a heavy metal cover which shall be kept locked when the filling pipe is not in use.

Sec. 23. The filling pipe shall be closed at the intake by a cock or valve fitted with a coupling for attaching to the hose of a harral wagon, and with a screw cap to close the opening when not in use.

Sec. 24. Each filling pipe shall be provided with a screen made of two thicknesses of 20-mesh brass wire gauze, placed not more than two inches below the filling cock or valve.

Sec. 25. The vent pipe shall be at least one inch in diameter, and shall run from the tank to the outer air at least ten feet above the roof of any building within a radius of twenty-five feet from the garage, and at least twenty feet from any window in adjoining buildings, and shall be well braced in position.

Sec. 26. The vent pipe shall be capped with a double goose-neck and provided with two screens made of two thicknesses of 20-mesh brass wire gauze and placed, one at or near the tank connection, and the other just below the goose-neck.

Sec. 27. The drawing-off pipe shall be not more than two and one-half inches in diameter in its largest dimension and shall be fitted with as many outlets as may be required, but not to exceed one for each floor of the garage.

Sec. 28. Each drawing-off pipe shall be encased in and surrounded by either six inches of Portland cement concrete or eight inches of brick masonry throughout its entire length.

Sec. 29. Each outlet for a drawing-off pipe shall be located in a separate compartment built upon suitable foundations having no opening except into the garage, and having walls, floors and roof constructed of Portland cement concrete at least six inches thick, or of brick masonry at least eight inches thick, the brick to be laid in and surrounded by Portland cement mortar. Each compartment shall be fitted with a self-closing iron door which shall always be kept locked except when oil is being drawn.

Sec. 30. No compartment wherein there is an outlet for drawing off volatile inflammable oil shall be situated in the area between the building and the sidewalk, or under the sidewalk, or within the stoop line; nor shall such compartment have a greater floor area than twenty-five square feet for one outlet and fifteen square feet for each additional outlet.

Sec. 31. The floor of each compartment wherein an outlet for drawing off volatile inflammable oils is located shall be graded to a common center and connected with a drainage pipe running into the oil separator.

Sec. 32. Each pump for delivering volatile inflammable oils shall be located in the compartment provided for in section 29 of this chapter, and shall be equipped with a shut-off valve with ground key on nozzle and with a check valve between the pump and the nozzle.

Sec. 33. Each compartment wherein an outlet for the drawing off of volatile inflammable oils is located shall be equipped with a ventilating flue, constructed of brick or concrete lined with tile pipe at least eight inches square inside measurement, and extending from the floor of the compartment at a point opposite the door to at least six feet above the highest point of the roof of the garage or any adjoining building within a radius of twenty-five feet of the garage.

Sec. 34. Each ventilating flue shall have an opening into the compartment 4 by 6 inches in area and three inches above the floor.

Sec. 35. Each flue shall be capped with a double goose-neck eight inches square, made of at least 18-gauge galvanized iron, with all openings covered with 20-mesh brass wire screens.

Sec. 36. The provisions of sections 29, 30, 31, 32, 33, 34 and 35 of this chapter shall not be held to apply to garages located in buildings that are of fireproof construction throughout. In such buildings no separate drawing-off compartment shall be required.

Sec. 37. It shall be unlawful for any person to deliver volatile inflammable oils from a storage tank to a motor vehicle by means of a



portable tank or directly through the outlet of the drawing-off pipe.

Sec. 38. Each portable tank shall be of a capacity not exceeding fifty gallons, and mounted on a suitable iron frame with rubber-tired wheels. The volatile inflammable oil contained in the tank shall be discharged only by means of a pump through a hose not exceeding eight feet in length having a shut-off valve close to its outlet.

Sec. 39. No pump or outlet for the delivery of volatile inflammable oils in a garage shall be allowed on any floor below the street level; and it shall be unlawful for any person to deliver a volatile inflammable oil to the tank of any motor vehicle while on the floor of a garage below the street level.

Sec. 40. Each portable tank used in a garage shall bear a number corresponding to the floor of the garage on which it is used; and it shall be unlawful for any person to remove a portable tank containing volatile inflammable oil from one floor to another floor in a garage.

Sec. 41. Each garage delivering volatile inflammable oils to a garage shall be equipped with a metallic hose having an automatic shut-off valve at the coupling next to the barrel containing such oils.

Sec. 42. No barrel containing volatile inflammable oil shall be taken off the wagon, but the oil shall be delivered directly to the storage tank of the garage through the filling pipe by means of a hose coupled to the barrel containing the oil and connected to the intake provided for in section 22 of this chapter.

Sec. 43. No wagon or other vehicle engaged in the delivery of volatile inflammable oils shall be admitted to or taken within a garage or any portion thereof.

Sec. 44. It shall be unlawful for any person to deliver to or receive within a garage any volatile inflammable oil in barrels or other receptacles, or to keep or store in a garage any barrel or other receptacle from which volatile inflammable oil has been drawn.

Sec. 45. Each oil separator installed in a garage shall be connected to the house drain and so arranged as to separate all oils from the drainage of the garage. The drainage from water closets in garages shall not be emptied into the separator, but shall be discharged directly into the sewer.

Sec. 46. It shall be unlawful for any person to throw or discharge any volatile inflammable oil into the urinals or water closets of a garage.

Sec. 47. The oil receptacle of an oil separator shall not exceed fifty gallons in capacity, and shall be emptied as often as may be necessary to prevent the oil from overflowing; and such oils as are recovered from the separator must be removed from the garage within twenty-four hours after being taken from the separator.

Sec. 48. All volatile inflammable oils spilled in a garage must be recovered by sponging or swabbing, and poured into the drain leading to the oil separator.

Sec. 49. A garage shall not be artificially lighted except by electric lights having air-tight tubes or bulbs or globes encased in suitable wire cages, fitted with keyless sockets. All electric switches and plugs shall be placed at least four feet above the garage floor.

Sec. 50. No system of artificial lighting other than incandescent electric lights shall be installed in any garage unless a certificate of approval for such system shall have been issued by the Fire Commissioner.

Sec. 51. No stove, forge, torch, boiler, furnace, flame or fire; electric dynamo, motor hoist or other electric appliance which is likely to produce an exposed spark, shall be allowed in any garage or in any building wherein a garage is situated, unless that portion of such building is separated from the garage by unpierced fireproof walls and floors.

Sec. 52. No motor vehicle shall be stored or kept in a garage unless the tank of such motor vehicle is equipped with a safety or fusible plug for which a certificate of approval has been issued by the Fire Commissioner.

Sec. 53. All fires and lights in or upon a motor vehicle shall be extinguished before bringing it into a garage, and shall not be lighted while the motor vehicle remains in the garage.

Sec. 54. It shall be unlawful for any person to smoke or carry a lighted cigar, cigarette or pipe within a garage or any room or enclosed place in which volatile inflammable oil is kept. A notice bearing in large letters the words "SMOKING UNLAWFUL," together with a copy of this section in smaller letters, shall be displayed in one or more conspicuous places on each floor of a garage.

Sec. 55. It shall be unlawful for any person to use or handle volatile inflammable oils within a garage for any purpose other than that of filling the tank of a motor vehicle.

Sec. 56. Each garage shall be permanently equipped with fire buckets filled with sand and kept on each floor, for use in extinguishing fires. A quantity of sand shall also be kept upon each floor of a garage for absorbing waste oils. The quantity of sand and the number of buckets for each garage shall be designated by the Fire Commissioner and stated in the permit.

Sec. 57. Each floor of a garage shall be equipped with self-closing metal cans, and all inflammable waste material shall be kept therein.

Sec. 58. All calcium carbide stored in a garage shall be kept in water-tight metal containers with securely fastened covers, but the aggregate quantity kept on hand at any one time shall not exceed fifty pounds.

Sec. 59. A person who violates any of the provisions of this chapter is guilty of a misdemeanor.

Sec. 60. (Sec. 25, Chap. III). For a garage permit issued under sections 5 and 6 of Chapter XXI of these regulations, the applicant shall pay an annual fee of Five Dollars for each motor vehicle stored therein.

Sec. 61. (Sec. 26, Chap. III). For a garage permit allowing the storage of volatile inflammable oils, the applicant shall file a bond in a penal sum to be fixed by the Fire Commissioner, but in no case shall the amount thereof be less than Five Thousand Dollars, and shall pay an annual fee of Fifty Dollars for a single storage tank and Twenty-five Dollars for each additional storage tank installed in such garage.

## CHAPTER XXII

### MOTOR VEHICLE REPAIR SHOPS

*Definition*—By the term motor vehicle repair shop is meant, a building, shed or enclosure, or any portion thereof, wherein motor vehicles are repaired for hire or by hired employees.

Sec. 1. Except as provided in the following section, it shall be unlawful for any person to keep or maintain a motor vehicle repair shop within the City of New York without a permit from the Fire Commissioner.

Sec. 2. A person holding a permit issued in conformity with the provisions of chapter XXI of these regulations shall not be required to obtain a permit under this chapter.

Sec. 3. Applications for permits to maintain motor vehicle repair shops shall give in detail the following information:

- (a) Name of applicant.
- (b) Location of premises where the repair shop is to be maintained.
- (c) Nature of construction of building.

Sec. 4. It shall be unlawful for any person to store or keep in a motor vehicle repair shop any volatile inflammable oil or calcium carbide.

Sec. 5. It shall be unlawful for any person to introduce or receive into a motor vehicle repair shop any motor vehicle containing a volatile inflammable oil, unless the building or that portion of the building occupied as such repair shop is of fireproof construction throughout.

Sec. 6. A person who violates any of the provisions of this chapter is guilty of a misdemeanor.

Sec. 7. (Sec. 28, Chap. III). For a permit allowing the operation of a Motor Vehicle Repair Shop, the applicant shall pay an annual fee of Twenty-five Dollars.

## CHAPTER XXIII

### MANUFACTURE, TRANSPORTATION, STORAGE AND SALE OF PETROLEUM, AND OTHER MINERAL OILS

Sec. 1. Except as otherwise provided in these regulations, it shall be unlawful for any person to manufacture, refine, transport, store, sell or deliver, any petroleum, or the liquid products thereof or of coal tar or shale oil, without a permit from the Fire Commissioner.

Sec. 2. Applications for permits to manufacture, refine or distill petroleum, coal tar or shale oil, within the City of New York, shall give in detail the following information:

- (a) Name and office address of the applicant.
- (b) Location of plant.
- (c) Manner and place of storing raw material.
- (d) Manner and place of storing finished product.
- (e) Nature of finished product.
- (f) Maximum capacity of the plant in daily output.
- (g) Name of each person designated by the applicant to have charge or supervision of the whole or a part of the plant.
- (h) Operation necessary for the manufacture of the finished product.

Sec. 3. In connection with the application mentioned in the preceding section, the applicant shall file a plan, in duplicate, drawn to a scale of not less than one-sixteenth of an inch to the foot, showing clearly thereon the following information:

- (a) Location of plant.
- (b) Nature of construction and dimensions of each building, storage tank and supply pipe in the plant enclosure.
- (c) Purpose for which each building is used.
- (d) Description and maximum quantity of material to be stored in each storage tank or building.
- (e) Maximum quantity of oil passing through each supply pipe per hour.
- (f) Location of each building with reference to nearest buildings outside the enclosure on all sides.

Sec. 4. The provisions of sections 2 and 3 of this chapter shall apply only to plants for the manufacture, refining and distilling of petroleum now existing in the City of New York, and no permit shall hereafter be issued for the erection or operation of any new plant of a similar character.

Sec. 5. It shall be unlawful for any person to transport, deliver or receive within the City of New York any volatile inflammable oil in a receptacle other than a galvanized steel barrel equipped with a safety or fusible plug for which a certificate of approval has been issued by the Fire Commissioner.

Sec. 6. The provisions of the preceding section shall not apply to the transportation of volatile inflammable oils when contained in glass bottles of not more than four ounces capacity each and plainly marked on the outside "DANGEROUS: Keep from Flame"; nor shall the provisions of said section apply to the transportation of such oils in cans of a capacity not less than one nor more than five gallons, for delivery only to persons holding permits for the storage and sale at retail of such oils.

Sec. 7. It shall be unlawful for any person to sell or deliver within the City of New York any volatile inflammable oil in quantities greater than one gallon unless the purchaser or receiver thereof holds a permit issued by the Fire Commissioner in conformity with these regulations for the storage, sale or use of such oils.

Sec. 8. Each vendor of volatile inflammable oils shall render to the Fire Commissioner on the first business day of each month a written statement, verified as to its correctness by an affidavit, describing the deliveries of volatile inflammable oils in quantities greater than one gallon made within the City of New York during the preceding month. Such statements shall be made upon forms furnished by the Fire Commissioner, and shall give in detail the following information:

- (a) Date of delivery.
- (b) Name of purchaser and number of his permit.
- (c) Place of delivery.
- (d) Quantity and kind of oil delivered.

Sec. 9. All cans used for the delivery of volatile inflammable oils shall be equipped with a metal seal so arranged that there shall be no outlet for the oil unless the seal is broken.

Sec. 10. No barrel, can, drum or package shall be used for the delivery of volatile inflammable oil unless a certificate of approval therefor has been issued by the Fire Commissioner.

Sec. 11. Petroleum and all liquid products thereof and of coal tar and shale oil, except volatile inflammable oils, may be transported within the City of New York in the following containers:

- (a) In tank cars or through supply pipes.
- (b) In steel, iron or wooden barrels, of a capacity not exceeding fifty-five gallons each.
- (c) In cans of a capacity not exceeding ten gallons each, made of galvanized iron or at least No. 24 B. & S. or I. C. charcoal tin or terne plate, and packed in substantial wooden cases.
- (d) In cans, drums or packages not exceeding ten gallons capacity each, made of at least No. 25 B. W. G. tin or terne plate.

Sec. 12. It shall be unlawful for any person to carry or transport within the City of New York any petroleum or the liquid products thereof or of coal tar or shale oil, in a tank wagon unless a certificate of approval has been issued therefor by the Fire Commissioner.

Sec. 13. The tank of a wagon used for the transportation of petroleum or the liquid products thereof or of coal tar or shale oil, shall be constructed of iron or steel not less than one-eighth of an inch in thickness for the top plates and three-sixteenths of an inch in thickness for the bottom plates, and equipped with faucets which shall be kept locked when not in use. The capacity of a tank wagon shall not exceed thirty barrels of fifty-five gallons each.

Sec. 14. All tank wagons shall have painted on both sides thereof, in conspicuous letters not less than two inches high, the name of the person, corporation or association operating the same, and the number of the certificate of approval.

Sec. 15. It shall be unlawful for any person to drive or have charge of a tank wagon in transit within the City of New York without having obtained a certificate of fitness from the Fire Commissioner.

Sec. 16. It shall be unlawful for any person to transport or carry in or upon a wagon or other vehicle, except a tank wagon, any petroleum or the liquid product thereof or of coal tar or shale oil, in quantities aggregating more than twenty-five barrels of fifty-five gallons each.

Sec. 17. Permits for the storage of a petroleum or the liquid products thereof or of coal tar or shale oil may be issued by the Fire Commissioner upon written application giving in detail the following information:

- (a) Name and office address of the applicant.
- (b) Location of plant.
- (c) Nature and maximum quantity of oil to be stored.
- (d) Name of each person designated by the applicant to have charge or supervision of the plant, and the number of his certificate of fitness.

Sec. 18. In connection with the application mentioned in the preceding section the applicant shall file a plan, in duplicate, drawn to a scale of not less than one-sixteenth of an inch to the foot, showing clearly thereon the following information:

- (a) Location of plant.
- (b) Nature of construction and capacity of each tank and building and the location thereof with reference to the nearest buildings not forming part of the plant.

Sec. 19. It shall be unlawful for any person to store or keep in a storage plant within the City of New York any petroleum or the liquid product thereof, or of coal tar or shale oil, in quantities in excess of the following:

- (a) Volatile inflammable oils: fifty steel barrels of fifty-five gallons each.
- (b) Other oils that do not emit an inflammable vapor below 100 degrees Fahrenheit; if in barrels, three hundred barrels of fifty-five gallons each; if in cans, a quantity not exceeding one thousand gallons; if in storage tanks, a quantity not exceeding fifty thousand gallons.

Sec. 20. Except as provided in the following section, all storage tanks shall be embedded in soft earth so that the tops thereof shall be at least two feet below the street level.

Sec. 21. For the purpose of facilitating the filling of tank wagons, there may be installed in a storage plant not more than four tanks, elevated on brick piers, and having an aggregate capacity of not more than five thousand five hundred gallons, for the storage of oils that do not emit an inflammable vapor below 100 degrees Fahrenheit. Such oils must be returned to the storage tanks underground each day at sunset.

Sec. 22. It shall be unlawful for any person to connect any part of a storage plant with a sewer, or to allow any of the liquid products of petroleum to escape into any sewer within the City of New York.

Sec. 23. It shall be unlawful for any person to keep or maintain a plant for the storage of petroleum, or any of the liquid products thereof or of coal tar or shale oil, unless such plant is continuously in charge of a person holding a certificate of fitness issued by the Fire Commissioner.

Sec. 24. No permit shall be issued for the storage of petroleum or any of the liquid products thereof, or of coal tar or shale oil, in any building which is occupied wholly or in part as a tenement house or dwelling, or in any building having more than one floor below the street level; nor for the storage of any such oils upon any floor of any building above the ground floor.

Sec. 25. Whenever the physical conditions along the shore front in the City of New York are such as to make it impracticable to place underground a storage tank for the storage of volatile inflammable oils to be delivered to launches and other vessels for generating motive power, the Fire Commissioner may, upon the recommendation of the Municipal Explosives Commission, issue a permit for a tank not to exceed two thousand five hundred gallons capacity, to be placed and maintained in such manner and under such conditions as the Municipal Explosives Commission shall prescribe, which conditions shall be clearly stated in the permit.

Sec. 26. For the purpose of filling the tanks of launches and other vessels using a volatile inflammable oil for generating motive power, such oils shall be transferred to the tank of such vessels directly by a pipe from a storage tank, and not otherwise.

Sec. 27. It shall be unlawful for any person to smoke or to carry a lighted cigar, cigarette or pipe within a storage plant where petroleum, or any of the liquid products thereof or of coal tar or shale oil, is stored or kept; and a sign bearing, in large letters, the words "SMOKING UNLAWFUL," together with a copy of this section in smaller letters, shall be posted in one or more conspicuous places in such plant.

Sec. 28. A person who violates any of the provisions of this chapter is guilty of a misdemeanor.

Sec. 29. (Sec. 31, Chap. III.) For a permit allowing the storage of petroleum, or any of the liquid products thereof, and of coal tar and shale oil, in a storage plant as provided for in section 17 of chapter XXIII of these regulations, the applicant shall pay an annual fee of One Hundred Dollars.

CHAPTER XXIV

STORAGE AND SALE AT RETAIL OF VOLATILE INFLAMMABLE OILS

*Definition*—By the term volatile inflammable oils is meant, any oil or liquid that will generate an inflammable vapor at a temperature below 100 degrees Fahrenheit when tested either in the open air or in the closed pyrometer of Giuseppe Tagliabue.

Sec. 1. Permits for the storage and sale at retail of volatile inflammable oils may be issued by the Fire Commissioner upon written application giving in detail the following information:

- (a) Name and office address of the applicant.
- (b) Location of the premises in which the oils are to be stored.
- (c) Nature of construction of the building.
- (d) Purpose for which the building is used.

(e) Nature of the business in which the applicant is engaged in such building.

Sec. 2. No permit shall be issued for the storage or sale of volatile inflammable oils within the City of New York in any building:

- (a) Which is occupied wholly or in part as a tenement house, dwelling, school or place of public assembly or amusement.
- (b) Where any explosives are stored or kept for sale.
- (c) Where dry goods of any kind are manufactured, stored or kept for sale.
- (d) Which is lighted by any artificial means other than electricity.

Sec. 3. No volatile inflammable oil shall be stored in a building for which a permit has been issued in accordance with the provisions of this chapter in quantities aggregating more than fifty gallons.

Sec. 4. It shall be unlawful for any person to store, keep, sell or deliver any volatile inflammable oil except in original packages with the seal unbroken, or to open any such package within the premises covered by the permit, or to sell or deliver any volatile inflammable oil in a quantity less than one gallon.

Sec. 5. It shall be unlawful for any person to smoke or to carry a lighted cigar, cigarette or pipe within any premises covered by a permit issued in accordance with the provisions of this chapter; and a sign bearing, in large letters, the words "SMOKING UNLAWFUL," together with a copy of this section, in smaller letters, shall be posted in one or more conspicuous places in such premises.

Sec. 6. The floor of each store or premises covered by a permit issued in accordance with the provisions of this chapter, shall at all times be kept clean and free from all accumulation of waste paper and other inflammable material, and shall be provided with self-closing metal cans for keeping sawdust or cotton waste used for cleaning purposes, and also with a number of buckets filled with sand for use in extinguishing fires; the number of buckets to be so kept shall be determined by the Fire Commissioner and shall be stated in the permit.

Sec. 7. A person who violates any of the provisions of this chapter is guilty of a misdemeanor.

Sec. 8. (Sec. 34, Chap. III.) For a permit allowing the storage and sale at retail of volatile inflammable oils, as provided for in chapter XXIV of these regulations, the applicant shall pay an annual fee of Ten Dollars.

CHAPTER XXV

STORAGE AND SALE AT RETAIL OF KEROSENE OIL

*Definition*—By the term kerosene or kerosene oil is meant, any liquid product of petroleum commonly used for illuminating purposes which does not emit an inflammable vapor below the temperature of 100 degree Fahrenheit when tested either in the open air or in the closed pyrometer of Giuseppe Tagliabue.

Sec. 1. It shall be unlawful for any person to store, keep or sell within the City of New York any kerosene or other mineral oil to be used for lighting purposes in quantities greater than five gallons without a permit from the Fire Commissioner.

Sec. 2. Permits for the storage and sale of kerosene and other mineral oils used for lighting purposes may be issued by the Fire Commissioner upon application giving in detail the following information:

- (a) Name and address of the applicant;
- (b) Location of premises;
- (c) Character of construction of building;
- (d) Purpose for which the building is used and number of families residing therein, if any;
- (e) Nature of the business in which the applicant is engaged in such building.

Sec. 3. No permit shall be issued for the storage and sale of kerosene or other mineral oil used for lighting purposes in quantities greater than seventy gallons in any building occupied wholly or in part as a tenement house.

Sec. 4. No permit shall be issued for the storage or sale of kerosene or other mineral oil used for lighting purposes in any building in quantities greater than two hundred and seventy-five gallons.

Sec. 5. It shall be unlawful for any person to store or keep any kerosene or other mineral oil used for lighting purposes except in the original package, or in a tank, can or container for which a certificate of approval has been issued by the Fire Commissioner.

Sec. 6. Certificates of approval for cans, tanks and other containers for the storage of kerosene or other mineral oils used for lighting purposes may be issued by the Fire Commissioner upon the recommendation of the Municipal Explosives Commission.

Sec. 7. It shall be unlawful for any person to sell or offer for sale any kerosene or other mineral oil used for lighting purposes which will emit an inflammable vapor at a temperature lower than 100 degrees Fahrenheit, when tested either in the open air or in the closed pyrometer of Giuseppe Tagliabue.

Sec. 8. All kerosene barrels, cans and containers shall be removed from the premises immediately after being emptied.

Sec. 9. A person who violates any of the provisions of this chapter is guilty of a misdemeanor.

Sec. 10. (Sec. 35, Chap. III.) For a permit allowing the storage and sale of kerosene or other mineral oils to be used for lighting purposes, as provided for in chapter XXV of these regulations, the applicant shall pay an annual fee of Ten Dollars.

Preparing for Richmond's Good Roads Meeting

RICHMOND, VA., Oct. 23—Novel, indeed, are the suggestions made by the executive committee of the Richmond Automobile Club for decorated automobiles during the convention of the National Highway Association, the week of November 20.

It is proposed to make the auto parade historical, depicting the men who settled Jamestown, the red men who watched them, the men of the time of Bacon's Rebellion, Governor Berkeley, Patrick Henry, John Marshall and "Light Horse" Harry Lee. The idea would be to put these historic men in automobiles and take them over the road to Petersburg and let them see the scene of the battle of the Crater, and other historical points.

President Taft has given every assurance that he will be here to attend the big highway meeting.

Seventeen Entries in Chicago Run

CHICAGO, Oct. 23—Seventeen cars are entered in the fifth annual reliability run of the Chicago Motor Club, which starts Friday for a 1,300-mile trip through five States. In the touring car class there are entered two Molines, two Halladays, two Staver-Chicagos and one each of the Case, Lion, Abbott-Detroit and Oldsmobile. The roadster division includes two Molines, two Velies, and one each of the Oakland, Bergdoll and Grout. The itinerary of the tour calls for night stops at Indianapolis, Louisville, Cincinnati, Columbus, Detroit and Grand Rapids. Sunday will be spent in Louisville. In addition to the contestants there will be several official cars—a Halladay pilot, a Packard pace-maker, a National press car, a Midland checker's car and a Haynes technical committee car.

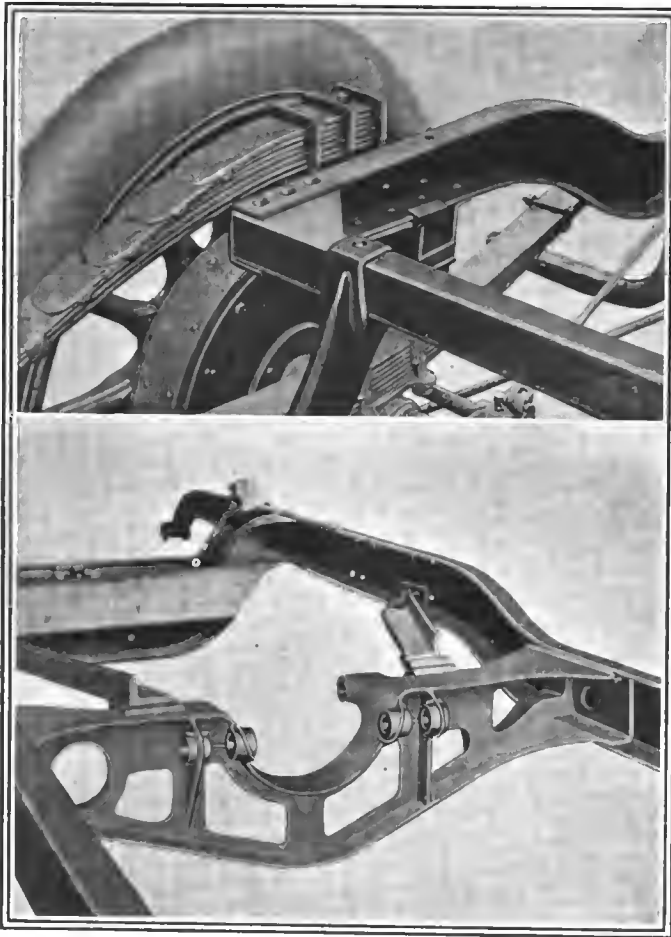

Fig. 5—Showing the attachment of rear springs on all Overland chassis for 1912 models

Fig. 6—The celebrated malleable iron cross member in the frames of all Overland cars

In the motor the thermo-syphon water piping has been increased in capacity from 25 to 75 per cent. in the different models. These pipes are aluminum castings. As in all thermo-syphon motors the radiator has to be well elevated above the cylinder heads. The aluminum crankcase is a two-part casting, the upper carrying the five crankshaft bearings, the lower constituting an oil reservoir and basin. In models 58 and 59 a mechanical oiler is used and consequently the lower part of the crankcase serves merely as a basin; whereas in 60 and 61 a circulating oiling system is used and the base of the case contains a sump or oil reservoir beneath the crankcase proper. In the circulating system the oil is delivered from the gear pump through a pipe to the middle of the crankcase, where it is poured against a divider of inverted V form cast on the inside of the case. The oil falling onto the apex of this divider is sent half to the front of the case and half to the rear. This supplies two splash levels and the oil splashed by the four connecting rods lubricates the crankshaft and camshaft bearings and also the cylinder walls, wrist pins and piston rings.

On models 58 and 59 the mechanical oiler is carried over the intake water pipe on the right side of the motor and has six leads, four to the cylinders, one to the rear crankcase compartment and one to the timing gear compartment at the front end of the motor.

A most important motor improvement on some of the models is the enclosing of the valve spring, Fig. 2, on the model 51. The cover for each valve spring is made up of semi-cylindrical parts held in place by two circular springs which surround them as clamps. A further improvement, one not shown in the illustration, is the method employed of preventing oil from leaking out by way of the valve stem. A real packing-box system is

used. The bottom of the valve-stem bushing, which sets into the cylinder casting, is formed with an annular recess and into this packing is fitted, a steel washer being used below the packing to retain it in position. The washer is in turn retained in place by a small spring similar to the valve spring, and located around the valve stem and inside of the valve spring. Provision is also made to prevent the valve-lifter rods from acting as plunger pumps and lifting oil which is splashed on their lower ends within the crankcase. The guide for the lifter is made with two vertical slots from top to bottom, in conjunction with an annular space at the top of the slots, so that the oil, which works up by the pumping action, flows off of the lifter into the slot and then flows down the slots into the crankcase, thus not only conserving the oil supply but aiding in keeping the motor clean—a potent factor in the modern car.

The Overland company has been a consistent exponent of the cone clutch, and continues its use. It is equipped with a clutch brake, which bears upon the cone face when disengaged to prevent its spinning, thus slowing it down and making gear shifting possible without grinding of the teeth of the meshing gears. Another clutch feature is the limited plunger action of the six radial plungers, which are regularly spaced around the cone periphery and bear outward beneath the asbestos facing. Each plunger stem is carried in a bracket attached to the cone. In the stem, near the clutch center, is a restricting pin, which, when the plunger presses outward 3-32 inch, bears against the bracket, stopping its movement. This prevents too quick engagement, or gripping when throwing the clutch in. The cone-clutch part is self-centering with the flywheel through the use of a three-arm spider, which bears upon a semi-spherical support, the semi-sphere allowing of the cone finding its own center.

The dual ignition system is used in all four chassis: On 58 and 59 the Splitdorf outfit is employed; on 60 it is the Remy, and on 61 use is made of the Bosch. The carbureter is the new Schebler model L. The carbureter is carried very low, the top of it being on a level with the lower half of the crankcase. Gravity feed is used.

One of the Overland frame features is the use of a malleable-iron cross-member, Fig. 6. This takes the place of forty-seven original pieces in the frame. It serves, in a word, to support the clutch and brake-operating parts and on its rear face are two eye-holes to which the arms of the yoke on the front end of the torsion tube, containing the propeller shaft, are attached.

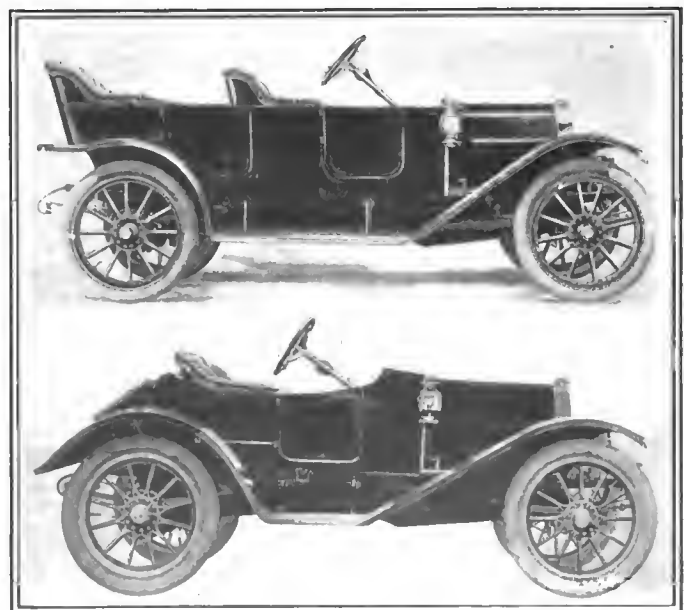

Fig. 7—Overland Model 59 touring car with 106-inch wheelbase and 32 by 3.5-inch tires

Fig. 8—Overland Model 58 roadster with 96-inch wheelbase and 32 by 3.5-inch tires

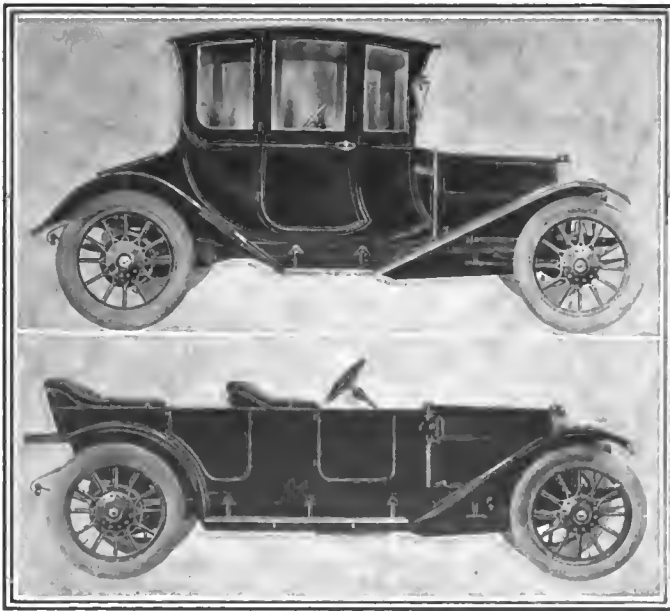

Fig. 9—Overland Model 61 coupé with 118-inch wheelbase and 34 by 4-inch tires

Fig. 10—Model 61 Overland touring car with 118-inch wheelbase and 34 by 4-inch tires

On all models the brakes are of the same design as used this year; that is, internal and external on the rear wheel drums. Fig. 11 shows the method of adjustment. On the brake rocker shaft is a sector, with a slot which has a toothed or serrated margin. The brake connection arm takes a pin with nut on the opposite end. By loosening the nut this arm can be set in any position in the slot in the sector and held there. This gives every possibility of range. By adding the springs all rattling of the external band has been eliminated. These are new. Quick disengagement of the expanding brakes is insured by the springs. The drum sizes are 10 x 2 inches on 58 and 59; 12 x 2 on 60, and 14 x 2 1-2 on model 61.

On all models semi-elliptic front springs are used. On 58 the rear springs are elliptics, but on the 59, 60 and 61 a three-quarter elliptic is used. Fig. 5 shows the bracket for attaching these springs to the frame. The spring is held by three clips and the lower part of the bracket is turned over or clinched on the lower lip of the frame. The heavy corner gusset reinforces the frame at this point.

Where selective gearshifts are used—and they are employed in all but one model—the three-speed set is made use of. On models 60 and 61 chrome vanadium steel gears are used and F & S annular ball bearings fitted. On models 60 and 61 an improvement in direct drive is the use of an internal gear into which meshes the sliding unit, in place of the dental-face teeth for locking the gears formerly used and still continued on model 59. Shifting is decidedly easier with the internal-gear scheme.

The precautions taken by the Overland company to prevent leaking of oil from the motor parts are also in evidence in the rear axle. With rear axles the big problem is to keep the lubricant in the differential housing, where it is needed, and prevent its leaking out at the ends of the axle sleeves and getting on the brake drums as well as on the spokes of the wheels. In this work two systems are used, the simpler on models 58, 59 and 60, and a more elaborate one on model 61. On models 58, 59 and 60 a packing is held at each side of the differential in the axle sleeves. It is retained by a washer at each side of it. The outer washer bears against a shoulder formed by the end of the axle sleeve and the inner washer is pressed against the packing by a coil spring. This holds the packing firmly in position.

In the model 61 a real stuffing-box scheme is made use

of. A stuffing box threads into the axle sleeve and is anchored there. The axle driver shaft where it passes through the stuffing box is ground to give a non-leak fit.

The Overland model 61 has other special features as compared with models 58, 59 and 60. One of these is a new gearshift. The gearshift lever works in a single slot, which is a feature in fore-door bodies and especially so if the shift lever is placed in the center of the car for manipulation by the left hand. The lever has a ball end, which is really not on the lever but on the latch which works inside of it. The lower end of this latch works in two slots, one located above the other, with a crossway between them. The different speeds are obtained as follows: By pushing the lever forward without pressure downward on the ball gives reverse, and pulling the lever back without downward pressure gives low speed. To get second speed the lever is moved forward with downward pressure on the ball, and to get direct drive it is pulled backward with the downward pressure. On the models 58, 59 and 60 a side movement of the gearshift lever is necessary.

### Increased Use of Aluminum

According to a recent article in the *Franfurter Zeitung*, the development of the aluminum industry has been unusually rapid. the world's production having risen from 11,500 metric tons in 1905 to 24,200 metric tons in 1909, and 34,000 metric tons in 1910. The distinctive feature about the aluminum trade is that it is in the hands of only 12 companies, of which five account for nine-tenths of the total output. The price of aluminum per kilo. (2.2 pounds) was \$6.50 in 1890, 50 cents in 1900, 80 to 90 cents in 1905, 27 to 36 cents in 1909 and 27 to 38 cents in 1910.

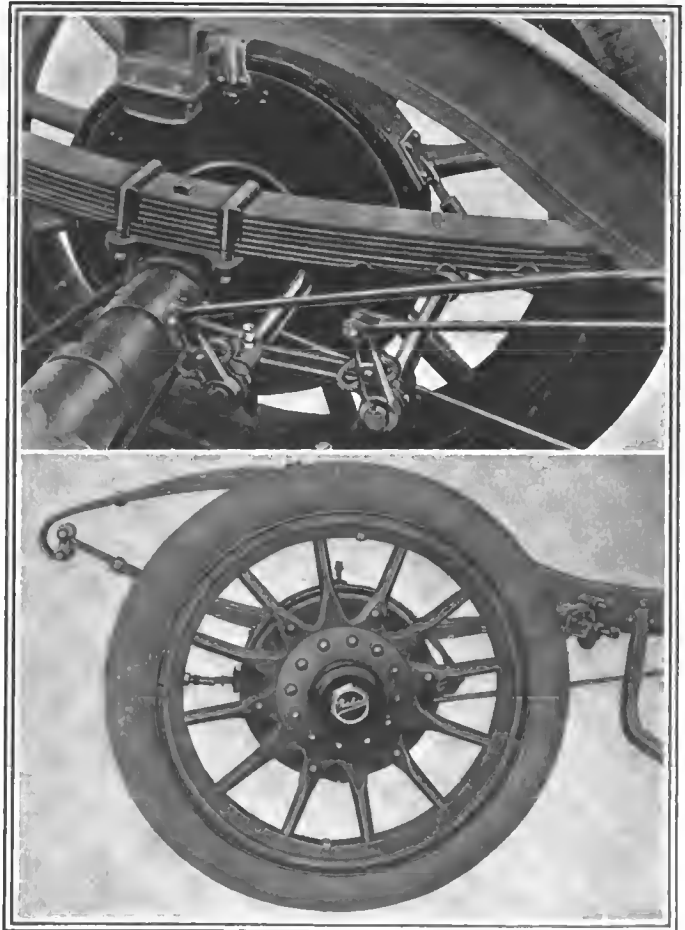

Fig. 11—Brake adjustment details on the different Overland models for 1912  
Fig. 12—Heavier wheels are used on the 1912 Overland models on all chassis



# The Automobile in Many Lands

**H**ERE are some new and interesting facts connected with the rubber plantation industry in the Malays. Contract laborers—Chinese coolies—on the rubber estates are a sturdy lot of men. A contract printed in English and Chinese, signed by the local representative of the Planter's Labor Bureau, is given to each man. The contract provides for eight hours' work per day, 24 working days per month and extra pay for overtime, monthly payment of wages due and free passage back to Hong Kong after the three years' contract shall expire.

There is wonderful activity in the rubber plantation industry all over the Malay States. Large areas of jungle lands are being cleared for plantation rubber growing. The forests, very dense, are being subjected to the same heroic treatment as is the case in Ceylon and British Guiana, where trees are being planted and cultured. The dense forests are being felled and the underbrush is burned away. Some of the men who realize the rapidly growing demand for paper argue that the wild rubber trees that are being cut down to make way for the plantation industry might be converted into pulp, instead of letting them go to waste. Everywhere in the southeast part of India interest in the new industry is taking on a marvellous impetus. Coolies are in great demand. The planters in the Malays claim that 15,000 coolies are needed to tap and collect the latex of 4,000,000 trees. The planters are beginning to wonder where they will be able to get a sufficient amount of coolies from when the rubber trees of the Malay Peninsula shall have increased to 45,000,000 in number. They are already casting eyes upon China in anticipation of the need of more coolies.

There is much to be done before the rubber is ready to ship from the Malays to London—the charge for which amounts to about \$17 per ton. There is the sorting process, work which requires great care, on account of the various prices that attach to the various grades of rubber, mixed lots selling at a reduction over lots that have been sorted after a system. The thin, transparent sheets and crêpes of rubber are most in demand in the market. After the rubber is put into cases—which are made in Japan, of white wood—it is weighed, a full case containing about 110 pounds. It is then carried to the transportation companies for shipment to London.

The high charges of the London rubber market have had the effect of inducing the plantation-rubber cultivators and buyers of the Malay States to organize a Rubber Exchange in Singapore. This in order that they may avail themselves of the opportunity to purchase raw rubber direct at the place of production. They argue that with this plan in operation they will be able to operate against the London brokers and extend the rubber market. The planters declare that up to the present time they have been absolutely at the mercy of the brokers and that for this reason they wish to have the business transacted near to the base of supply. Singapore being the center of the rubber-producing belt, it offers every advantage as a place of sale.

One firm in Singapore disburses \$5,000,000 worth of raw rubber annually. A member of the firm is authority for the statement that by establishing an exchange a large portion of the para rubber output of the plantations would be marketed there, including Borneo, Malaysia, Sumatra and Java, and for the reason that the planter would be able to obtain the best prices. The services of the local middle-man would be less expensive, and at

Rubber Industry in the East Indies Is a Most Important One—Help Becoming Scarce—Emperor William Now Owns Thirty Automobiles—Mexican Rubber Prices—English Signal Regulations—Other News Items from Continental Districts

the same time more effective, than those of the broker thousands of miles away. The Exchange would be under obligation to prove that prices would be fair, made by free competition of the members to buy and sell

the product entrusted to them. The Exchange would serve as a general storage plant, as well as a meeting place of members, and the business would be handled by a staff of experienced men.

The total amount of cultivated rubber exported from the Federated Malay States and Ceylon during the last seven years was 26,854,842 pounds.

Except in the case of re-exports from England or France, it is out of the question to buy American-made tires in Rio de Janeiro. The automobile accessories imported into Brazil yearly amount to \$150,000, and yet the United States gets only \$12,000 worth of this trade. Such accessories are sold there almost exclusively by agents representing European automobile houses. Another disadvantage which the American manufacturers of rubber tires encounter is the fact that the automobile trade is monopolized by European houses.

Rubber seed has become a valuable commercial factor in China, where it is proving a fine food for cattle. It is also an effective fertilizer. The seeds yield a clear oil, not inferior to linseed oil.

The new motor-car system of taxes went into force in Sheffield on the first day of September, 1910. Licenses are issued upon the basis of horsepower units, and they are apt to make cars an expensive luxury—one which none but the rich or the very extravagant could afford to carry even if so disposed. The new tax rate is from \$4.86 for a motor-bicycle to \$204.39 for a car above 60 horsepower. Many of the larger types of touring cars are being offered for sale at a sacrifice. The demand for cars above 20 horsepower is limited. The most popular cars in and about Sheffield are 15-horsepower machines. On cars of these dimensions a duty of \$19.47 is levied.

The gauge of automobiles in Nuremberg and vicinity is from 4 feet and 1 inch to 6 feet and 1 inch, the size of the car governing the gauge. This is wider than the standard gauge of other vehicles, which is from 3 feet and 7 inches to 3 feet and 8 inches.

There are now about fifty automobiles in Yarmouth, Nova Scotia. This number includes twelve new machines purchased during the year ending in October, 1910. Of the half-hundred machines, thirty-four were manufactured in America. During the Summer half a dozen Canadian-made cars were brought to Yarmouth by cottagers.

Emperor William of Germany has just purchased four more new types of automobiles, thus augmenting his motor car fleet to thirty and again emphasizing his stand as an enthusiastic motorist. The majority of his machines are of German and French make. Six of these cars are utilized as luggage vans. The Kaiser keeps five of his automobiles at Corfu. No other person is permitted to possess a horn like that used on His Majesty's motor cars, the type of horn being that of a peculiar fanfare. When in commission the car bears the Imperial Standard flag, which flies beside the chauffeur by day. This ensign is replaced at night by an illuminated glass shield, revealing the Standard in regulation colors.

English law makes it compulsory upon automobilists to "carry a bell or other instrument" on motor cars. To this end the Local Government Board says that the signal "shall be used whenever necessary." This rather indefinite phrase is some-



times hard to interpret, for example, in a case of alleged neglect, when the matter is referred to a Magistrate. But the problem of the motor car horn, "hooter," siren or "road clearer" has become so great and the kinds of "instruments" in use so numerous that both motorists and pedestrians are in a muddle. To get out of it they are considering the feasibility of calling upon the respective Local Government Boards to agree upon some one definite type of horn to be used. Throughout the country English motorists seem to show a liking for a certain type of bugle, which contains ten notes, comprising the diatonic scale of the key of G, with F sharp and an extra A added.

France has just introduced a new type of motor truck. It is equipped with a tilting platform, about thirteen feet in length, and a capstan. The truck has a capacity for carrying loads of great weight, which, by reason of platform and capstan, are handled both in the loading and unloading at a wonderful saving of hand labor. The platform is tilted over the rear axle, while the loading truck is run out upon the ground. After having loaded the goods upon the truck, the workmen draw the truck back upon the tilting frame by means of the capstan. The frame is then tilted back and locked in its place. Not only have manufacturing concerns and commercial houses adopted the truck, but the military authorities have put it into commission.

Eisenach, Arnstadt and Apolda, in Germany, each maintain extensive automobile manufacturing plants and the output of motor cars and accessories from these factories is growing at a tremendous rate. Naturally, the demand for tires keeps pace. The people residing in the Erfurt region, where the above-named towns are located, know very little about American-made tires, Germany having supplied the bulk up to the present time, although there is one Great Britain firm which keeps a supply of tires in a branch factory in Germany. Tires made in France also go well in this vicinity. Upon the whole, Germany is beginning to demand a higher grade of tire than formerly used. Upolda and Arnstadt manufacture tires principally for small motor cars, the price of which is about \$1,000 or less. The Thuringia hill country in the Erfurt section affords some of the grandest roads in Germany. The great touring cars made in this locality comprise high power, with a relative light weight, the automobiles made here being especially designed with the view to hard climbing. Heavy tires that will stand up, endure the strain over the mountain highways and not skid are in demand. At the same

time these machines must be built so as to resist snow and ice.

The fact that a uniformity of prices prevails in the case of German-made tires stimulates the supposition that this line of industry, as it is conducted in the German Empire, yields a fair amount of profit to the manufacturers.

The requirements of the metric system obtain in Germany, as they do in Great Britain. Some of the American manufacturers have shown a disposition not to conform to patterns of automobiles built for export to the requirements of the metric system. This has proven to the disadvantage of American trade in Germany, at least in the matter of fixtures and mechanical attachments.

Manufacturers of rubber tires in Germany carry on an extensive business not alone with small dealers in automobiles, but they sell direct to the motor car factories. The customary terms given by German manufacturers are thirty days, with 2 to 3 per cent. discount for cash.

Some of the German tire manufacturers give a guarantee on tires "for 10,000 miles, to be run within twelve months from the date of delivery," under conditions which restrict the heft of loads.

Although crude guayule (Mexican) rubber, which sold for a time at \$1.25, has dropped to 60 cents the pound in gold recently, the production in the Torreon section of that country does not seem to have fallen off. The amount of the product shipped from Mexico between November 23 and December 14, 1910, is given as 1,474,000 pounds. New York received the greater portion of it. In addition to this output the State of Coahuila has been coming to the front with a product of guayule rubber which has yielded something like \$450,000 per month. There is a concern in Mexico whose product is over 1,500,000 pounds per month. The promoters are endeavoring to build up a European trade, especially in Germany, France and England. A considerable amount of guayule rubber has already been shipped to these countries. Estimates showing the cost of manufacturing the crude rubber from the guayule shrub run all the way from 40 cents the pound down to ten cents the pound. A great many contracts were made in the beginning—some of these are still in force—for shrubs at from \$25 to \$30 Mexican money per ton. The price at which the shrub is purchased and the expense involved in delivering it to the factory have a great deal to do with the extent of the profit.

## Harking Back a Decade

THE following extracts have been taken from the *Motor Review* of October 24, 1901:

Alexander Winton has accepted an invitation from the Detroit Driving Club to use the Detroit track in an attempt to regain the mile track record now held by Fournier, which was wrested from him a few days ago.

George V. Brower, Commissioner of Parks of New York, having given his formal approval to the use of the Coney Island boulevard on Saturday afternoon, November 16, from 1 o'clock until 5, The Long Island Automobile Club announces a series of races for gasoline and electric vehicles, the horsepower of the gasoline vehicles to range from 6 to 20 horsepower.

The first annual convention of the National Association of Automobile Manufacturers, for the discussion of trade topics, will be held in the assembly room of the Madison Square Garden during the week of the automobile show on the forenoons of Tuesday and Wednesday, November 5 and 6.

The Stearns Steam Carriage Company, Syracuse, N. Y., has completed a new style surrey which will be sent to New York to be exhibited at the Madison Square Garden show. The surrey has a boiler of 621 flues and engines of 12 horsepower.

The municipal council of New York City last week aimed a blow at automobiles and their drivers by passing a resolution to enforce the automobile laws now in existence to the end "that pedestrians on the streets, avenues and roadways of the parks and passengers in vehicles drawn by horses may be protected."

The Long Island Automobile Club conducted its initial run of the season on October 12, reaching Garden City at 2 p. m., where a special dinner awaited the chauffeurs, among whom were a number of women.

At the Providence, R. I., race meet it was expected that William K. Vanderbilt, Jr., with his Red Devil, and Foxhall Keene would be present, but owing to accidents to the machines they were unable to start. Arthur C. Bostwick with his 40-horsepower Winton went after records on the track. He soon had the spectators on tip-toe, and when it was announced that his first mile was made in 1:20¼ the people realized that there was speed in the machine. He made the 10 miles in 14:09¾.

Albert Champion, the noted French motor bicycle chauffeur, broke the world's records for 2, 3 and 4 miles in his race yesterday at Vailsburg, N. J. His times were: Two miles, 2:32; 3 miles, 3:50; 4 miles, 5:07, and 5 miles in 6:24.

# Special Windshield Adaptations

By GEORGE J. MERCER

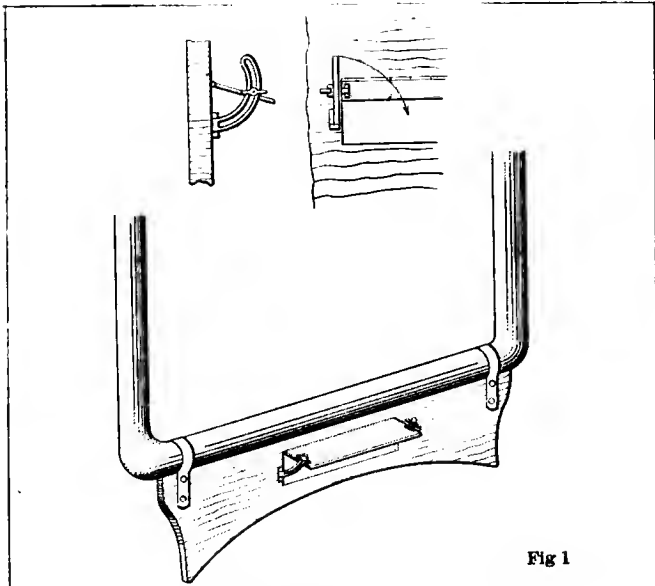

Fig 1

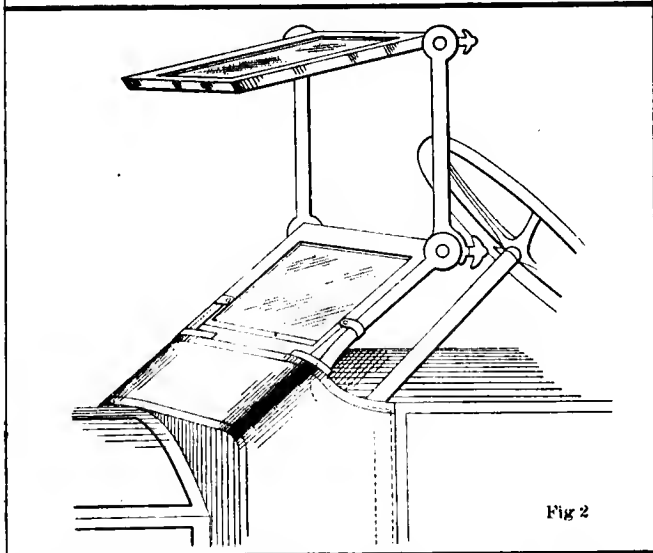

Fig 2

Fig. 1—Ventilator in base board of windshield for fore-door bodies

Fig. 2—The zigzag type of windshield with a leather filler board used

WITHOUT casting any discredit on the general appearance of the stock windshield, it is only reasonable to suppose that the shield made to conform to the body design, and built to the body as a part of it, will always carry a class that the ready-made product is lacking. It is quantity production against custom work and the price is according. Two illustrations, Figs. 3 and 4, show the altogetherness and harmony of design with the shield that is built on the body. The first design, Fig. 3, is used in this country on the Metallurgique car and it is the writer's impression that originally it came out on the English Daimler. It has merit both for its clean, symmetrical appearance as well as for its practical worth. It is made to conform to the design of the body front, the lower panel being a continuation of the cowl. The side rods are made to bend gracefully at the point of intersection with the cowl and are continued down and inside the body to form a supporting brace.

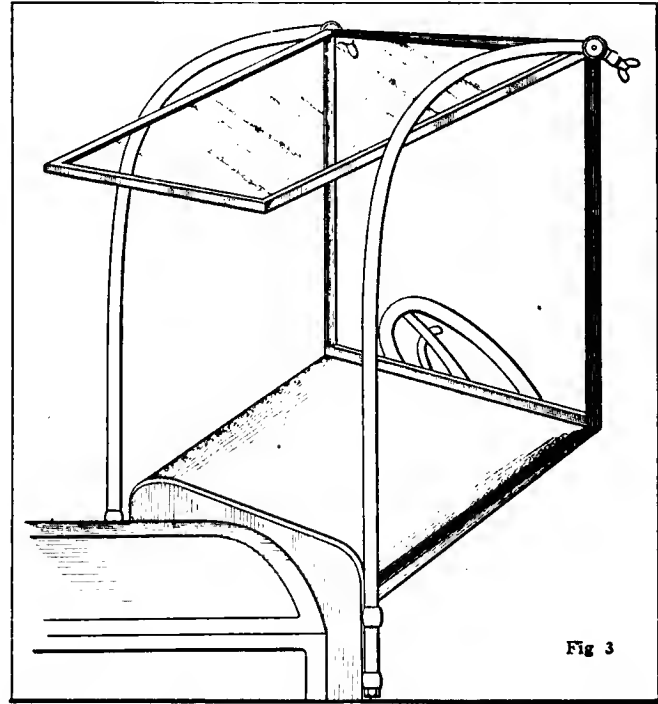

Fig 3

Fig. 3—A type of windshield that has many points of merit and is adaptable to many makes of cars on the market to-day

The use of thumb nuts for fastening the swinging frame in position is shown on the illustration, but there is nothing to prevent the use of the automatic fastening and it would improve the shield, in fact it will soon be an impossibility to market a windshield that is not automatically fastened or made to operate with one hand.

In Fig. 4 is illustrated a shield made on the body. It is generally used on cars that have a very high cowl and where the owner is used to driving his car without an extension top. It can be tilted to any angle desired, the point of turning being at the bottom. The method of securing the braces to the body is shown and no stay rod is required at the front. It can be quickly removed from the body and the painted surface of the cowl is not left scarred as with the ordinary shield.

In Figs. 5, 6, 7 and 8 are four views of an English-made shield that does duty as a protection for the occupants of the rear seat of the car. A friend of the writer's assured him that this shield is as effective as its advocates claim, and his experience during a recent tour in England has made him a convert to its merit, especially for the between seasons when the air is raw and full of misty rain and the wheels are splashing the mud around and the wind is strong enough to carry it back to the tonneau of the car. Figs. 5, 6 and 8 show the plan, front and side views of the shield in position ready for use, and the arrows on the plan view show the means of folding the shield as well as indicating the means of extending or shifting the shield to best suit the needs of the user. It will be noted that there is great flexibility and the supports are made suitable to hold the shield rigid in a great variety of positions.

Fig. 7 indicates the position of the shield when folded and out of commission; it is made to lie closely to the rear of the front seat and there is in addition a shirt or cloth that hangs from the bottom of the frame. This cloth is long enough to

almost touch the floor of the body and its object is to carry the protection afforded by the glass down to a point that the wind cannot enter, and when the glass frame is folded, as indicated in Fig. 8, this cloth can be made to fold over the same in the manner of a robe over the regulation robe rail. This cloth is not shown in the illustrations, as its effect would be to hide the more important parts of the shield.

The windshield until quite recently was listed as an extra by automobile manufacturers; that is, the stock car was a complete unit without it and the purchaser simply went a little deeper into his pocket if he thought a shield was essential to complete the outfit. Any doubt that existed in his mind as to the usefulness of a shield to him as a car user was generally founded on the fact that an inefficient article was being handed to the public at an inflated price because protection from the elements during certain months of the year must be provided for in some manner and a good windshield together with a good top will add the necessary comfort to the touring car and the runabout.

The commercial windshield on the market to-day is uniformly good and the variety is sufficiently large to suit nearly all requirements. The range of models extends from the simple shield, made of celluloid and pantasote, to the intricate shield with metal frame that can be made to assume a variety of different angles for deflecting the wind and the rain and that can also be made to collapse when not required. All these types of shields are common to car users and the description of such will be confined to the new feature that has lately been added to some models now on the market, that is, the ventilator that allows a current of air to be forced downward around the feet of those seated in the front of the car, the object being to offset the heated conditions that exists where fore-doors are used. Fig. 1 illustrates a standard make of shield with a ventilating door in the filler board. It is simply a metal door at the rear or inner side and is hinged at the top so it can be raised to permit the desired opening. The method of fastening is shown enlarged on the two sectional views at the top of the illustration. The slotted side arms are hinged at the bottom and when the door is closed these arms turn, as indicated by the arrow, and lie flat against the door, thus eliminating any projections from the board when the door is closed. The ventilator is still an experiment and the new shields coming out will no doubt present a variety of methods for accomplishing the desired result.

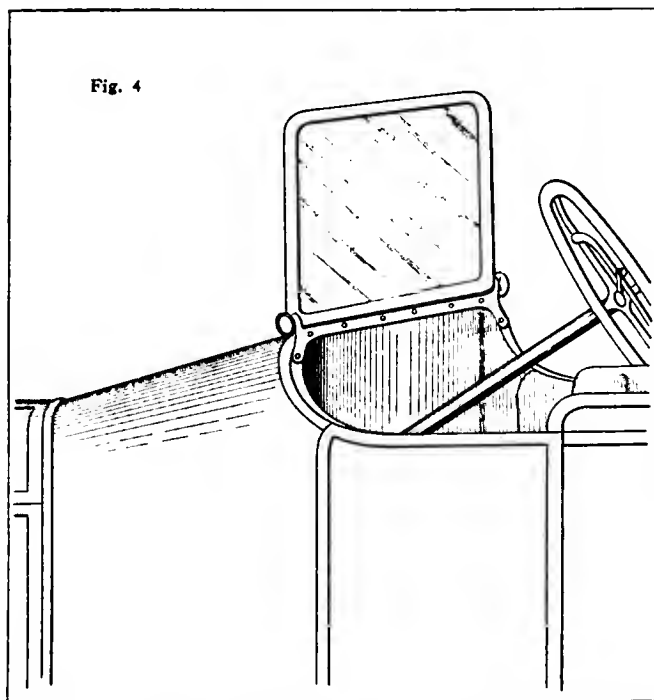

Fig. 4—This illustration shows the results that can be obtained when a windshield is designed to especially suit the cowl dash and where its design harmonizes with the body lines of the car

Fig. 2 illustrates an essentially custom-made shield which can be made to fit any car easily and can be quickly removed or put on. It is easy to operate and is of the zigzag type without being as heavy as the usual shield of that style and the davits or side rods hold the frame firmly without the aid of stay rods. The lower panel is formed of leather and underneath this panel is a small rod from the dash to the frame to keep the latter from swinging forward. The leather will keep it from going backward. With this as with the zigzag shield the extension top can be made the minimum length forward over the driving seat. This shield is an American improved adaptation of the French model brought out a few years ago.

A SUBSTITUTE FOR PLATINUM.—The great increase in the price of platinum, which is due to its scarcity, is resulting in a brisk demand for another rare metal which seems destined to take its place in many industrial applications. Palladium is the metal which possesses practically all the properties of platinum, being extremely hard, malleable, ductile and refractory to acids. Lately this substance has been obtained in relatively large quantities from the mining districts of Ontario, Canada. In the reduction of 200,000 tons of nickel ore 3,000 ounces of palladium is one of the valuable by-products.—*Riviste Mensile del Touring Club Italiano.*

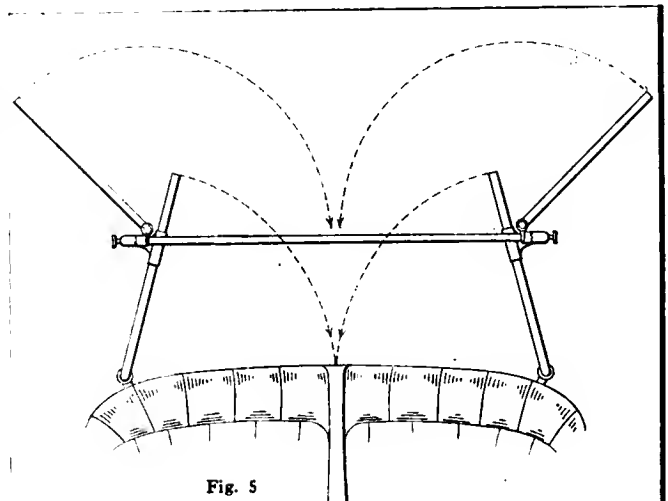

Fig. 5

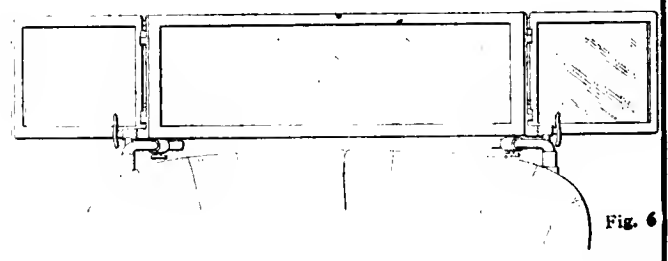

Fig. 6

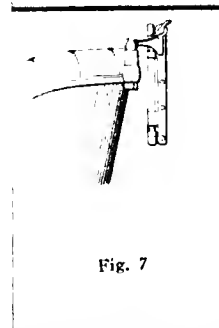

Fig. 7

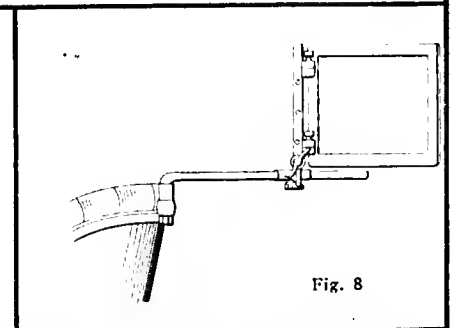

Fig. 8

Figs. 5, 6, 7 and 8 show different views of a type of windshield that can be carried on the back of the front seat of a car and used for the benefit of those in the tonneau. It has a wide field of uses and is a big comfort factor in a car

# Digest of the Leading Foreign Papers

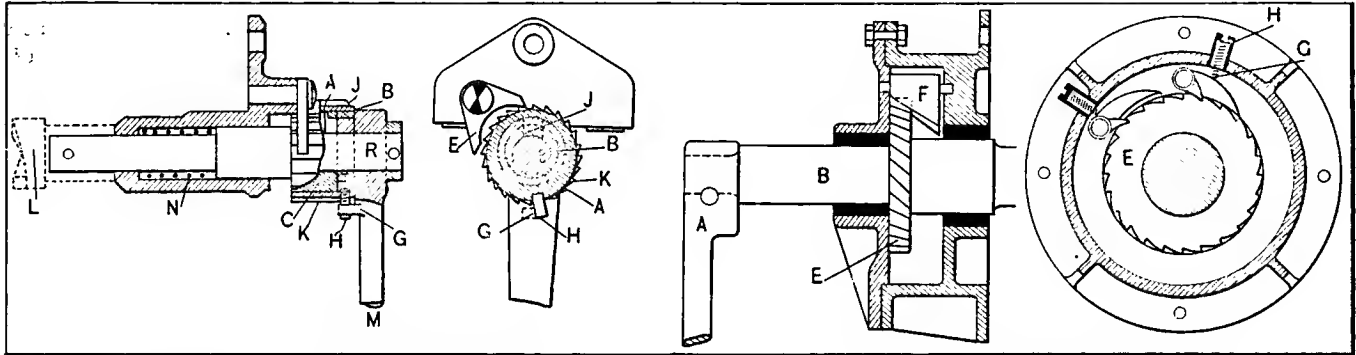

Fig. 1—The Clemencet safety starting crank

Fig. 2—The Castagnet safety starting crank

## FIFTY-EIGHT competitors responded to a call from the Industrial Society for the

### Safety Starting Cranks

Prevention of Accidents in the Performance of Work when the latter planned an international test of devices for preventing all unintentional rotation of cranks for hoisting apparatus, such as cranes, winches and iron shutters for stores and warehouses, and particularly of starting cranks for automobiles. The object was to arrive at some standard construction by which accidents could be eliminated.

With regard to starting cranks it was required that the devices submitted for test should effect the immediate disengagement of the crank the moment the engine is either started in the normal direction or backfires. Only sixteen of the fifty-eight devices submitted met this condition and five out of these sixteen were for various reasons not presented at the trials, leaving only eleven to be compared and judged in practice. Some of these are herein partially described and illustrated.

The Clemencet safety crank, Fig. 1, is connected with the motorshaft by the customary jaw-clutch *L* and release spring *N*. The boss of the arm *M* is mounted idly upon the motorshaft extension *R*, but its axis is eccentric in relation to the axis of the shaft. On the arm there is a dog *G* to receive the thrust of disengagement. On the shaft *R* there is formed an integral collar *C* and a sleeve *A* mounted idly upon it with its cylindrical bore having the same eccentricity as that of the crank boss; its surface is provided with ratchet teeth *K* acting against the ratchet pawl *E*, so that the sleeve can turn only with the sun. This sleeve also carries the dog *H*, and when this dog *H* is nearly in contact with the dog *G* on the crankarm the center of the sleeve coincides with the center of the crank-boss and there is therefore room between the boss and the sleeve for the cylindrical ring *B*, which engages a slot in collar *C* by means of feather *J*. It must therefore rotate with collar *C* and shaft *R*. The operation is as follows: When the crankarm is turned for starting, dog *G* has no action on dog *H*. The eccentricity of the crank boss causes ring *B* to be gripped at once, carrying shaft *R* with it. And sleeve *A*, which can move in this direction, is also carried along, so that the whole system turns, dog *H* following dog *G* a few tenths of a millimeter behind. When the motor starts it does not take the crank with it, even if the customary release device fails to work; in fact, sleeve *A*, being free to rotate on collar *C* on shaft *R*, is held from movement in this direction by dog *H* abutting against dog *G*, and the ring *B* turns freely. If the motor backfires and turns the shaft *R* in the opposite direction the sleeve *A* is immediately stopped by the pawl *E*, the dog *G* is arrested by the dog *H* on the sleeve *A* and the ring *B* turns freely. The crank *M* is thus immediately

released in either case when the motion is started from shaft *R*.

In the Castagnet safety crank, Fig. 2, the shaft *B* of the crank *A* carries a miter gear *E*. Two pawls *F* are so placed that one or the other can act at once, being spaced half a tooth apart in their action (though the illustration does not show it). They are applied against the miter gear by means of two helical springs *G* enclosed in the hollow adjustment screws *H*. The end of the crank spindle is provided with the usual clutch for gripping the motorshaft. In operation, if a reverse movement is produced, the crank tends at first to being carried along, but by reason of the angle of the pawls and the form of the gear teeth there is produced a longitudinal displacement of the spindle which causes the immediate disengagement of the clutch.

In the David safety crank, partially shown in the sectional view, Fig. 3, the crank hub is mounted upon the motorshaft *A* by means of a shoulder, a washer and a screw nut. The crankarm is secured to the collar *H* by a cotter. The collar *H* is externally concentric with the shaft *A*, while its bore is slightly eccentric. Two segments *K* and *K1* are placed in the space between the collar *H* and the shaft *A*. *K1* is secured to the collar *H* by screws, but *K* is notched to receive the rollers *g* and carries on one side the helical spring *r* and on the other the spring pawl *m*, which passes through a mortised hole in the collar *H* and engages a ratchet ring. When the crank is turned for starting the collar *H*, being eccentric, pinches segment *K* between itself and the shaft *A*, and the latter is rotated, while the pawl jumps from tooth to tooth. When the motor starts *K* is loosened and the crank is freed. If the motor is reversed the pawl immediately releases *K* and the crank is again free.—From *Bulletin Official*, August.

**MOTOR POWERS FOR FARM AND SHOP**—In reply to an inquiry, the following estimates are offered with regard to the work which may be entrusted to a gasoline motor, automobile or otherwise, particularly referring to work which in common European practice has usually been done by hand or horsepower.

The 4-horsepower motor can operate a threshing equipment (as distinguished from the portable threshing machine outfit), which has previously been worked with two horses. A 6-horsepower motor will take care of an equipment intended for four horses and with a capacity of about 150 bushels, in the case of wheat, per day. A 2-cylinder motor of 8-horsepowers will operate an equipment turning out 250 to 300 bushels of wheat per day and provided with a chaff-blower, a cleaner and a mechanical

binder. With the same equipment a 10 to 12-horsepower motor will increase the output about 50 per cent.

Eight horsepowers will operate a circular saw cutting about 14 inches deep at the rate of 3 feet per minute. With a bandsaw the depth of the cut may be doubled.

The 4-horsepower motor will produce electric light for forty lamps of 16 candlepower each, at a cost of 5 cents per kilowatt (would be 2 cents per kilowatt at American prices for gasoline, provided the motor did not waste the difference by reason of poor design). An 8-horsepower motor is sufficient for running a moving-picture machine or to light a hall with a seating capacity for 300 to 500 persons.

The 4-horsepower motor will turn at the same time a cream separator, a churn, a feed-mixer, a kneading machine and a washing machine on a farm of medium size. It can pump sufficient water in 1 hour from a depth of 90 feet for supplying a farm of 200 to 300 hectares (1 hectare equals 2.4 acres) with all the cattle usually kept on such an acreage. It is also amply large for doing all the power work in a small brewery and for running all the tools in a cabinet maker's shop. In a machine shop it will run at the same time two lathes, three drills, a milling machine and an emery grinder.

With 2 more horsepowers the farmer can run at the same time a chaff-cutter or a crusher and a root-cutter, a pump and a sheep-shearing machine.

A contractor with a motor of 4 to 6 horsepowers can transport by wagonets 2,000 cubic meters or yards of excavation material in 700 hours over a distance of 3 kilometers and with

a difference in levels of 300 meters. He could take the same quantity a distance of 150 meters and to a level 15 meters in 35 hours.—From *La Vie Automobile*, Sept. 23.

**How to SAVE FUEL**—First of all give the carbureter plenty of air. In nine cases out of ten the mixture used is unnecessarily hot after the motor is once warmed. When running down hills, either take the clutch out and throttle the engine to dead slow, or shut the throttle off altogether and let the engine brake against the compression whenever possible. In this case there should be an air inlet upon the induction pipe, to be opened so as to prevent the formation of partial vacuums in the combustion chambers and the resulting flooding thereof with lubricating oil. Or else, the gear can be put into the neutral position and the engine stopped—that is if it starts easily off the switch on every downgrade. Much fuel may be saved by keeping the pace down to the most economical speed, which for ordinary cars is generally about 20 to 25 miles an hour on the top gear, as above this speed the wind resistance comes in as an important factor in adding to the work to be done by the engine and puts up the fuel consumption at once. Lastly, there must not be any racing of the engine up hills on any speed, and the engine must not be left working when any stop over half a minute is necessary. In a month's running of about 1,000 miles, the writer has been able to save about 9 gallons of gasoline, by following these precepts, making 17 1-2 miles per gallon instead of 15 miles, as by his previous driving practice.—From *The Car*, Sept. 27.

# Mexican Rubber Industry Develops

TORREON, MEXICO, Oct. 10—The industrial world may well be astounded at what has been accomplished in the development of the guayule rubber industry during the last 7 years in Mexico and Texas. The report of the Federal government just issued shows that during the last fiscal year there was exported from Mexico refined and crude guayule rubber to the value of \$32,985,679. This was an increase of \$6,757,490 over the value of the guayule rubber exportations of the preceding fiscal year. But for the interruption of the different rubber manufacturing plants during the period that the revolution was in progress the value of the product manufactured during the year would have reached nearly \$50,000,000, it is said. For several months several of the larger factories in the Torreon district were shut down and nothing was done upon the ranch lands in the way of cutting the shrub.

When the fact is considered that 8 or 9 years ago the guayule shrub was unknown as a source of rubber supply and that since the discovery that it yields a good quality of the product more than \$60,000,000 has been invested in the industry in Mexico and about \$2,000,000 in Texas, the enormous annual production that is now being obtained is remarkable.

Practically all of the guayule rubber produced in Mexico is exported to the United States, where it enters largely into the manufacture of automobile tires and electrical appliances. Owing to the fact that most of it is mixed with the Para product when it gets to the refineries and manufacturers it loses its identity as to name so far as the general trade is concerned.

It is not known here what the production of guayule rubber in Texas during the last fiscal year amounted to, but it is said to have been considerable. The development

of this industry in Northern Mexico and in the upper Rio Grande border region of Texas means that the United States is now equipped with a new element of industrial greatness. The supply of guayule shrub is practically inexhaustible. It is indigenous to a region embracing many millions of acres of land that is almost worthless for any other purpose. The shrub belongs to the semi-desert class of vegetation and grows slowly under natural conditions, but it has been proved by experiments that by cultivation it can be made to attain a commercial size in 2 years after planting. In its wild state it takes about 4 years to reach the desired height for cutting. The shrub is being extensively propagated in Mexico and Texas and experiments are being made in growing it in New Mexico and Arizona.

The two largest guayule rubber producing interests in Mexico are the Madero family, to which President-elect Francisco I. Madero, Jr., belongs, and the Intercontinental Rubber Company and its subsidiaries, which is controlled by the Rockefeller-Aldrich syndicate. This city is the chief manufacturing center of the industry. Besides the large rubber factories that are situated here a number of others are scattered through the states of Zacatecas and Coahuila.

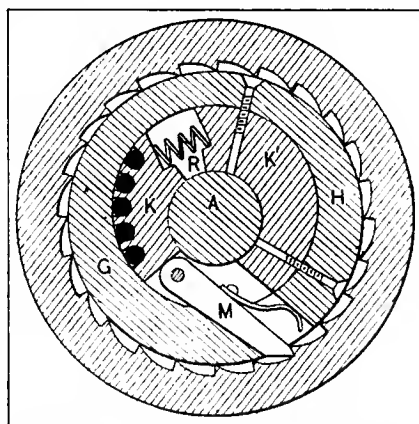

Fig. 3—The David safety starting crank, which was one of the competitors in the contest promoted by the Industrial Society for the Prevention of Accidents in the Performance of Work

ONE OF THE THINGS which a careful automobilist should always have at his disposal is a stick which is notched at various points along its length. The stick can be inserted into the gasoline tank opening for the purpose of determining the amount of gasoline in the tank. The notches are laid off in spaces which represent a gallon a notch. When the stick is withdrawn the part which is wet will indicate the depth of the gasoline.



# Letters Answered and Discussed

## Use a Pair of Calipers

Editor THE AUTOMOBILE:

[2,880]—I wish to determine whether a steel shaft that I am going to use as a drive-shaft for a piece of machinery has any taper or if it is perfectly straight and if the same diameter throughout its length. Could you tell me any accurate method of determining the taper, if there is any, and how I can measure it? READER.

Davenport, Iowa.

The simple calipers are about as good

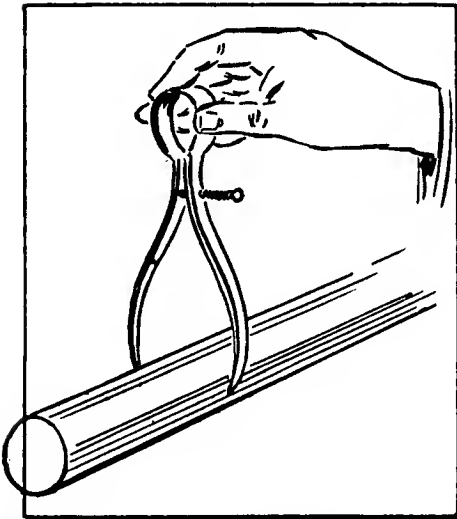

Fig. 1—Calibrating a shaft is the best method of detecting taper

a tool as there is to use for the purpose you desire. The calipers are held above the shaft, as shown in Fig. 1, and allowed to slip over the shaft in such a manner that they are not sprung as they are slipped over, but the points just fit snugly over the shaft. The calipers are set at this measurement and then tried at various points along the length of the shaft. If they will not pass over the shaft, or if they pass too loosely, there is an irregularity in the shaft which may be scaled as follows. The calipers are set to the part of the shaft with the largest diameter and then moved along the shaft. The differences are obtained by inserting a feeler gauge between the calipers and the shaft.

## Testing for Radiator Leaks

Editor THE AUTOMOBILE:

[2,881]—I know that there is a leak in my radiator but I do not know where it is. Would you kindly tell me how to go about finding it? The radiator is of the tubular type. H. W.

Mount Vernon, N. Y.

As the average car owner has no supply of compressed air on hand he may use a tire pump. The radiator is placed in a tub of water, as shown in Fig. 2, and the tire pump connected to it. A plug is placed in the water outlet at the bottom of the radiator and the air pumped in. Bubbles coming from the leak will indicate exactly where it is located.

The leak may be readily repaired by means of a little prepared solder. The solder is made so that the metal is cored out and the flux placed in the center. This will save the trouble and time of preparing the flux outside of the work of soldering. The prepared solder generally comes in sticks and can readily be used with a candle or match. If matches have to be used, two or three of them can be burned at once so that the flame will be hotter than that given forth by one match. It will often be found that a candle is not handy just at the time it is needed for the repair work.

## Has Carbureter Troubles

Editor THE AUTOMOBILE:

[2,882]—Will you kindly give me reasons for my trouble? I have a single-cylinder motor which I am unable to start. Everything seems to be in good condition, but I can get no explosions except by putting my hand over the intake pipe of the carbureter and shutting off nearly all air; in this way I can occasionally get very weak explosions, but the carbureter will flood in a very short time.

I have tried adjusting the carbureter in every way possible but can get no results. The carbureter is about 6 inches from the cylinder and is connected to manifolds of 1-inch brass pipe. J. U. H.

Salem, Mass.

The symptoms given may apply to many cases and it is difficult to say what the cause of the trouble might be. Examine the manifold connection to the engine and carbureter to see if there is a leak which manifests itself at either of these points. The needle valve of the carbureter perhaps requires grinding in order to prevent too great a flow of gasoline into the float chamber. The float of the carbureter may bind or stick in such a way that the gasoline supply is not properly regulated. Take the carbureter from the engine and examine the float for the purpose of determining whether there is anything which interferes with its action. There might be an air lock in the piping from the tank to the carbureter. Do not permit any vertical bends in the piping. Perhaps there is

no vent in the fuel tank to permit the air to enter as the gasoline leaves. As a final resort, if the above causes are not suitable to your case, the carbureter should be sent to the factory for examination as it is probably defective. This advice is based on the assumption that the other parts of the motor are in good condition.

## Wants Non-Freezing Solution

Editor THE AUTOMOBILE:

[2,883]—During the Winter months I store my car in a garage where the temperature often drops below the freezing point. Consequently I have to drain my radiator to prevent it from being damaged. Do you know of any solution which one could add to the radiator water to prevent freezing under ordinary temperature conditions, and, at the same time, be absolutely harmless to the circulating system?

W. C. MAND.

Chatham, N. J.

Denatured alcohol is about the most commonly used solution; it is harmless and effective. A 20 per cent. solution will freeze at about 10 degrees above zero; this is a proportion of 1 quart of denatured alcohol to 1 gallon of water. A 30 per cent. solu-

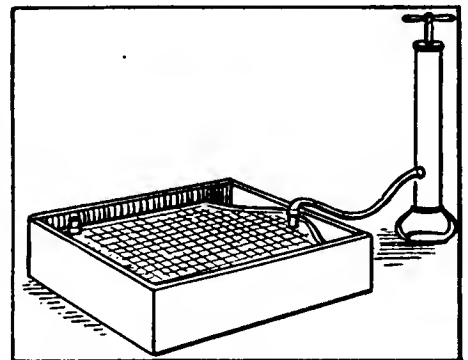

Fig. 2—Illustrating method of testing for leaks in radiator

tion, 1 1-2 quarts of denatured alcohol to 1 gallon of water, would freeze at about five degrees below zero. Freezing point of water is at 32 degrees above.

## Care of Mohair Tops

Editor THE AUTOMOBILE:

[2,884]—What is a good dressing to make mohair tops waterproof? How is it applied? MURRY FAHNESTOCK.

Alleghany, Pa.

In the issue of September 7, on page 394, there is an answer to a similar question which will cover this case. In other words mohair tops should not be dressed.

Wants Article on Transmission

Editor THE AUTOMOBILE:

[2,885]—I am very much interested in your paper and would like to see an article on transmissions, progressive vs. selective types. Just at present I am having trouble with my gearset, having broken a countershaft and two main shafts. The gears are noisy and rumble while in mesh and the car jerks when going slow if I disengage the clutch with either first or second gear in mesh.

J. W. REEVE, JR.

New York City.

The gearset you employ is no doubt inadequate to fit the needs of the car and should be replaced by one made by a reliable concern. It is very well possible that the clutch is also in need of refacing if it takes up fiercely at low speeds. If it is a leather faced cone clutch it should be blocked out of engagement by propping the pedal and castor oil applied. A liberal coating of oil should be given and allowed to stand over night.

Uses Too Much Oil

Editor THE AUTOMOBILE:

[2,886]—As a subscriber to your valuable paper, I would like to ask you some questions regarding my engine.

The front cylinder seems to let oil through it when running; I have taken the cylinder head off and find that the rings are tight. I poured oil in the cylinder with the head down about 1-2 to 1 inch from the top and poured oil into the cylinder. It held the oil tightly and the cylinder has splendid compression.

The engine runs very well but it consumes entirely too much oil. As there are no leaks in the crankcase outside of a few drops, I cannot understand where it goes

or how it gets into the top of the cylinder. None of the other cylinders give any trouble in this way the trouble being entirely confined to the cylinder nearest the radiator. It gathers carbon quickly while the other cylinders rarely have to have their spark plugs cleaned; the motor runs as noiselessly as the majority and is economical in all respects except in the matter of lubricating oil.

ED. C. BATES.

Clarksville, Tenn.

If you will take the piston rings out and replace them you will find that this trouble will disappear. The trouble is that while the engine is running the oil will be forced past them because they are worn.

Illustrates Score Board

Editor THE AUTOMOBILE:

[2,887]—I take pleasure in sending you a photograph of the score board of the fourth annual 200-mile race of the Quaker City Motor Club (reproduced in Fig. 3), held in Fairmount Park, October 9. I am sending this because it is a complete story of the standing of the cars in the race, and because as a work of art it stands alone in this respect. This board is 22 ft. high by 44 ft. long, and the excellent system that the writer inaugurated as official timer and scorer enabled the public in 95 per cent. of the time to obtain figures from fifty seconds to one minute and ten seconds after the cars had crossed the tape. In other words, to show our excellent timing and scoring there was only a delay of from fifty seconds to seventy seconds after a car would cross the tape before the painters would have the score recorded on the board.

No time in the history of automobile racing has there been a score board of this character provided that afforded a correct

record of the race and the score so quickly recorded.

Believing that this photograph and the above information will be of interest to you, and that you kindly acknowledge receipt of this, I remain,

Yours truly,

PAUL B. HUYETTE, M.C.

Philadelphia, Pa.

A Little Road Incident

Editor THE AUTOMOBILE:

[2,888]—As a little illustration of how hospitable people will be along the roads I wish to relate an experience I had the other day while taking a short cross-country tour up in Connecticut. We were going along the road at a fair rate of speed when the car skidded in turning a corner and ran into a telegraph pole. The steering knuckle snapped and we were left helpless upon the road.

Evening was approaching and a rain-storm threatened at any moment, the wind blowing out of the northeast with all the discomfort accompanying it which a northeaster can possibly bring with it. There were two ladies in the car, and the roads were in no fit state for any pedestrian, so we were "up a tree."

While we were debating what to do under the circumstances, an old farmwagon hove in sight and, seeing our plight, stopped. After considering us for a short time in the way of countrymen, he announced that he had some neighbors who lived nearby and they would be glad to shelter us from the rain. It had started to fall. Well, to make a long story short, we sat down to the best kind of a New England dinner and the farmer's son guarded the machine until help arrived from a nearby village which was blessed with a garage.

C. Q. D.

New York City.

Table titled 'QUAKER CITY MOTOR CLUB Fourth Annual 200 Mile Race' showing race results with columns for Division, No., Car, and time intervals from 1 to 25.

Fig. 3—Illustrating the score board used at the Fairmount Park races recently

# Little Bits of Motor Wisdom

## Pertinent Pointers of Interest to Repairman and Driver

**CAM ACTIONS**—The principle of the wedge is not applied in a more useful form than in the cam. In nearly all machines some part of the mechanism is manipulated by means of the action which is imparted to its various parts by a cam arrangement. In the internal combustion engine this principle has been utilized to the greatest extent in the operation of the valve mechanism. To secure the greatest efficiency possible with a given engine the valve action must be correctly timed, the gases must be admitted to the cylinder at the proper instant and must flow into the cylinder in such an interval of time that the required weight of charge is in the cylinder and at the same time not overlap any other part of the cycle in such a way that it will interfere with it.

In the case of an average valve timing, which was compiled by taking the timing of several different cars and striking an average between them, the cams were arranged so that the inlet cam held open the valve which it manipulated during the time that the crank passed from 10 degrees past the upper dead center until it reached a position 30 degrees past the lower dead center. The exhaust cam in this case was arranged so that it held the valve open from 40 degrees before lower dead center on the end of the explosion stroke to 5 degrees past upper dead center. It will be noticed that while the inlet valve was held open for 110 degrees the exhaust valve was held open for 135 degrees. This difference in the length of time that the valves are held open will entail a difference in shape of the cams which may be well brought out by illustrating the cams on an average en-

gine. The cams shown in Figs. 2 and 3 bring out the difference in contour between the exhaust and inlet valve cams. The cams which have the longest face are for the exhaust action while the shorter faced cams are for the inlet. If the actions of the inlet and exhaust valves were similar so far as time of opening were concerned the shape of the cams would naturally be exactly similar, though they would be set at a different angle on the camshaft.

There are many variations so far as the relative valve opening and closing times are concerned; these variations being based on the different theories of the designers of the various makes of engine. There are two principal theories, however, which hold sway at the present day in the inlet timing of the four-cycle motor. According to one idea the inlet valve should open before the exhaust valve closes so that the entering charge will aid in scavenging the motor by sweeping out the remainder of the dead gases. The other scheme, which is used by the majority of engine builders, is to have the inlet valve open shortly after the exhaust is closed. In the average engine above mentioned, the period between the closing of the exhaust and the opening of the inlet valves is 5 degrees in the crank circle.

**USING THE HACKSAW**—The hacksaw is among the tools which may be used for a variety of purposes. Four of the different pieces of work which may be accomplished with this useful tool are shown in Fig. 4. The operation indicated by A, in this illustration, is one of cutting a piece

from a solid block. This is a tedious piece of work at best, but could not be accomplished by any other hand tool as simply as it may be done by means of the saw. The work may be clamped in the vise in the manner most convenient for the workman to proceed with the operation and may be shifted from time to time according to

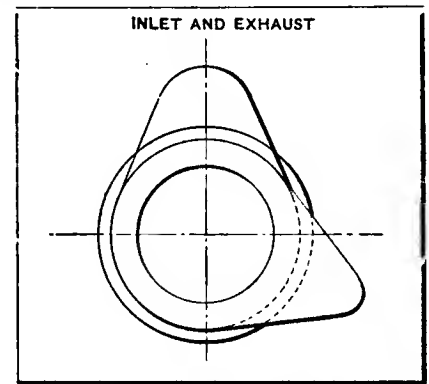

Fig. 2—Showing the relative shapes of the inlet and exhaust cams

the manner in which it is required to make the cut.

At B the operation of removing a tight bushing without damage to the part containing it is shown. If the bushing is removed by driving it from the pinion, there is a great chance that the pinion would be marred or the teeth destroyed or damaged in some way. By using the hacksaw a simple vertical cut or two may be made which will permit of the removal of the bushing without trouble. A wise precaution which may be taken in performing this operation or any other in which the part is clamped within a vise, is to slip a piece of wood between the jaws of the vise and the part enclosed within them. The wood being so much softer than the metal will take up the squeeze of the vise and hold the part firmly, yet at the same time the sharp metal edges of the vise will not be able to mar the metal.

It may sometimes be necessary for the automobilist who strays far from the beaten path to make himself a gearwheel which will at least fill the position of a disabled member for a short length of time. At C this operation is being carried out. It will take a long time to do it, but in the case where the automobilist is far from the factory or nearest service plant it will perhaps take him a shorter time to set to work with the saw than it would for him to wait until the needed part ar-

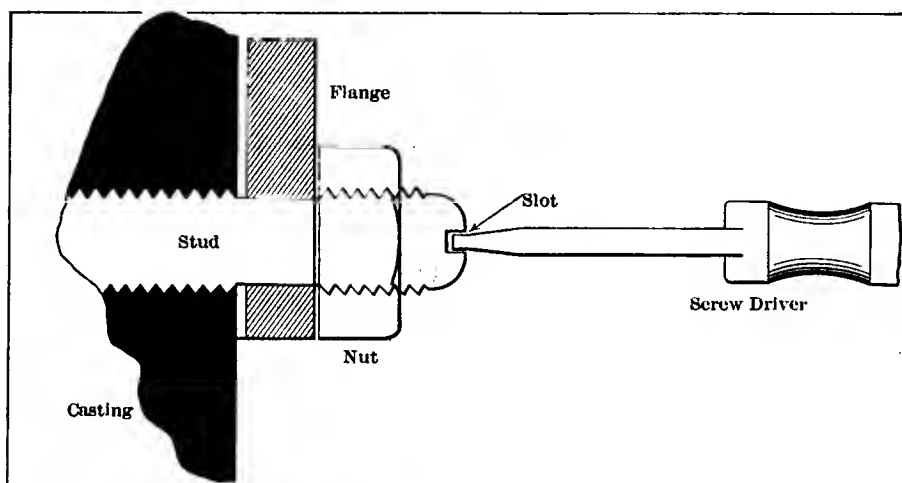

Fig. 1—A case where a stud may be fitted which can be adjusted by means of a screwdriver

rives. The broken gearwheel will serve as a guide and template in laying out the new wheel; or, if the old wheel be lost, the diameter of the pinion required may be measured on the machine itself. The number of teeth in the wheel will depend on the function it is called upon to fulfill. It may be easily calculated at any rate by remembering the simple rule that the number of teeth upon a gear wheel of any size varies directly with the diameter of the wheel when the pitch of the teeth is constant. The pitches of the teeth on wheels which operate in mesh with each other are naturally the same.

It may often be the case that a screw of a certain size will be required at a place and that there are none available. If the operator is equipped with a hacksaw the problem will resolve itself down to about a half hour's work. A bolt of the same size as the screw required may be clamped in the vise. The head is then sawed off by a horizontal cut. The next operation is depicted at D. The operator has merely to make a vertical cut into the top and a perfect screw will be made. The threads may be filed from the top if it is desired.

**SCREWDRIVER HANDIER.**—There are many instances where the parts which require frequent adjustment on the automobile are not so accessible as they might be. In fact accessibility is just becoming prominent in the minds of those to whom the world looks for the best in automobile design. In the automobile, as well as in all new mechanical devices, the first developments lie almost entirely along the lines of the really essential features, while those things which would tend towards the greater comfort and convenience of the operator of the machine, and yet are not an absolute necessity in the construction, were not considered of prime importance.

It will often happen that a nut is fitted upon the motor at such a place that while it may be entirely within reach before the motor body is mounted upon the chassis or the motor itself placed within the chassis, yet after the assembly has been made it requires a series of gymnastic feats to tighten the nut after it has been removed. The nut may be brought home a considerable distance and yet it will be a physical impossibility to give it the final turn which will produce the necessary tightness of fit. This is generally the case where the wrench can not be properly applied owing to the cramped position.

The screwdriver can often be used in cases where it would be impossible to attempt to use a wrench, so that if the end of the stud is threaded as shown in Fig. 1, it may be screwed home by the screwdriver. The nut in this case would act merely as a lock-nut. The screwdriver would have to be large in order to do its duty properly in a case of this kind, as there would naturally have to be a considerable amount of force employed to turn the stud home as tightly as if a wrench were employed. The greatest advantage in the use of a wrench is the amount of leverage which can be employed when it is desired to tighten the nut as firmly as possible. A screwdriver, however, if composed of good material so that it will not crumble away at the end if pressure is placed upon it, will be perfectly capable of turning the nut as far as it is necessary. In many instances the end of the screwdriver may be flattened and the wrench placed over this part of it.

It will be a matter of but a few minutes to make the change described above and of applying the screw-headed stud to a part such as is depicted in Fig. 2. The nut will take some of the strain, so that it will not all be upon the threads within the tapped hole. The screwdriver will be much handier to manipulate in the cramped space than the wrench, and will be found to give adequate satisfaction so far as tightness is concerned. A point to remember in connection with the neatness of the job is that the length of the end of the stud screw should be regulated so that there will not be a long shank projecting out behind the end of the nut. A small amount may be allowed; that is, enough so that there will be no danger of the stud being shorter than the end of the nut.

**USE STRAPS FOR BAGGAGE.**—The ancient rope is one of the most useful of man's servants, but in spite of this fact it has its limitations, which cannot be denied. One of these limitations is in the line of its use as an instrument in holding baggage upon the automobile.

A buckle is ever so much more conveni-

ent than a knot, no matter with what skill the latter may have been tied, and when the weather happens to be rainy the truth of this statement will be demonstrated. A strap may easily be unbuckled, and then, if it is desired to fasten it in any other place after changes have been made, it is very simple to punch a new hole in the strap at any place along its length and fasten it at that point. When baggage is carried in two or three suit cases which are tied together it is much more simple to have them bound by straps in place of ropes.

The leather of the strap should be well taken care of. This is a point which is often overlooked, and yet it is of considerable importance so far as economy is con-

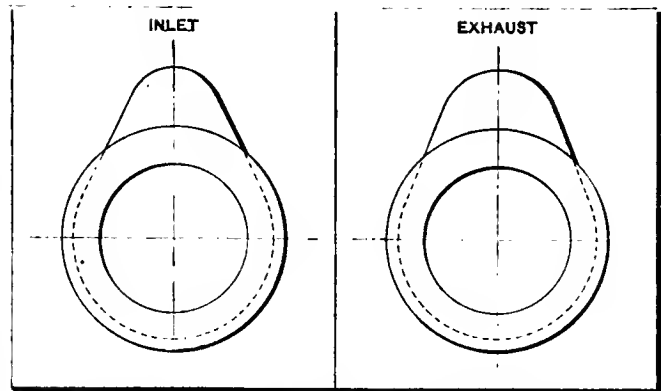

Fig. 3—The inlet cam has a shorter period than the exhaust

cerned. A little neat's foot or castor oil will keep it pliable.

**WHEN A VALVE IS DISABLED.**—It is not necessary to throw the hands up in despair if the valve on one of the cylinders of a multi-cylinder engine is disabled, as it is very well possible to get home on the other cylinders without a great amount of trouble if a few simple steps are taken. The inlet passage can be sealed so that it is impossible for the cylinder to draw in a charge of fuel. The exhaust valve should also be closed so that there will be no chance for the motor to suck dead particles into the cylinder.

A good method of sealing the valves is to open the joint where the gasket is inserted and putting a blank gasket in place. The cover is then bolted on, and the engine is ready to be operated in spite of the break. The motorist is able to get home in this way without the slightest fear that any damage will be done to the motor further than the valve breakdown.

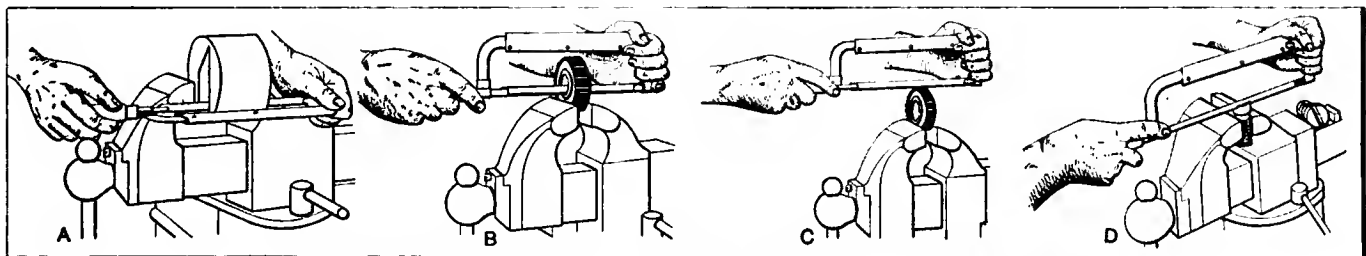

Fig. 4—Depicting four different operations which can be carried out by means of a hacksaw

# My Best Automobile Repair

## Some Quick Repairs Made in the Garage and on the Road

### Used Leather Washers

Editor THE AUTOMOBILE:

In answer to your interesting invitation to automobilists to send in a description of their temporary or permanent repairs, I am sending you a sketch (Fig. 1), showing how I made a temporary road repair on my left front wheel after the cones had burst when descending a steep hill; and by the use of three leather washers went merrily on my way.

The illustration shows a section through a hub. The end of the axle A rested on ball bearings, which were located at B. P is a cotter pin through the nut, and C the cap. The hub of the wheel is indicated at H and is shown riveted to the wheel. It was at the point W that the accident happened, and at the time I had only been driving and owning a car for four weeks.

I went to a farmhouse and procured a piece of leather, which I cut into washers. These washers I fitted as shown at W. I took a great deal of care that this point was very copiously lubricated after I had fitted them as shown, and I am sure I could have ridden 100 miles without damage to the car in any way.

This repair took me 45 minutes, and considering the short length of time that I had been driving the car, the scheme was a great success, as I had no trouble in

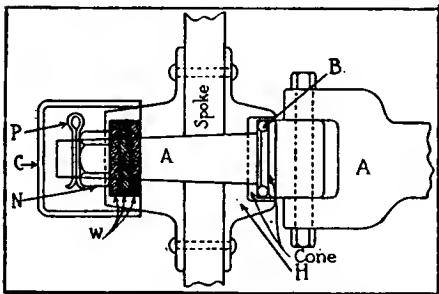

Fig. 1—A repair made by a reader when the cones had failed in descending a hill

reaching a point where a permanent repair could be made.

W. B. WHITE.

Zelienople, Pa.

### Made a Tire Pump

Editor THE AUTOMOBILE:

In answer to your invitation for readers to send in their roadside experiences and repairs, I am sending you a description of a tire pump which a friend and I made, and although it is not exactly a repair, may interest you, since it is along the same line.

*Temporary automobile repairs made by the driver or owner while on the road and permanent repairs made in the garage after the run is over, are interesting to all automobile owners.*

*It may be a spring leaf has broken; a shackle bolt or strap may break; a steering tie rod is bent; the car skids into a curb and bends a steering arm or the starting crank; a throttle or magneto connection breaks owing to vibration; a radiator leak is started by a stone or some other means; a leak in the gasoline tank is discovered; there is a small hole in the gasoline feed line; a brake facing may burn out; a brake connection breaks; a front axle gets slightly sprung; a clutch starts slipping, or any one of a thousand things may happen.*

*Every automobile owner is interested in knowing how repairs have been made, how long it took to make them, how much they cost, and by whom they were made.*

*We want you to write in simple language in a letter what repair of this nature you have had to make, how you made it, how long it took you and how much it cost.*

*You can make with your lead pencil one or two rough sketches indicating the broken or damaged part and showing how the repair was made.*

*The experience of each reader is interesting to every other reader. Analyze your past experiences and send in one or two of them.*

*Give your name and address, legibly written. If you do not want your name to appear, make use of a nom de plume.*

Editor THE AUTOMOBILE.

The pump was made out of fittings which can be found in any plumbing or machine shop, and is so simple that it is merely a matter of screwing the parts together. It will do the work every bit as well as a pump which costs many dollars, and yet does not cost more than \$1.50. It fits into the sparkplug, and the engine does the work.

The pump is shown in Fig. 2 and consists of but nine pieces of material. Reading from the left to the right on the illustration the inlet is at I; A is a 3-8-inch check and forms the inlet piece. The T-piece P screws into the sparkplug and is of 1-2-inch standard gas pipe; upon the top of this piece is fitted a release cock C. Another check of the same size as the first screws into this at A, and fitted upon the top of this there is a pressure gauge G. The union U is inserted in the line for the purpose of connecting the hose H to the pump. The hose H leads directly to the tire and is fitted with a valve for connection. This pump will put pure air into the tires and will allow the engine to do the work without any trouble.

ED. C. BATES.

[The opinion of our readers on these contrivances and repairs is invited—EDITOR.]

### Made a Rope Tire

Editor THE AUTOMOBILE:

Once while I was out on a rather rough road I blew out one of the rear tires. I had been going along very steadily at a moderate rate, when suddenly the tire blew out. I stopped the car and after examining the tire was at a loss as to how to proceed, as I did not wish to completely ruin a casing which was bad in only one spot. The road was very rough and I could not proceed on the flat tire without hopelessly cutting it up, so I took a piece of rope and by binding it on tightly after removing the casing from the rim I made a fair imitation of a tire, which took me to a garage without cutting either the rim or the casing.

I. H. P.

Detroit, Mich.

### Broke Valve Spring

Editor THE AUTOMOBILE:

Once while running along a rough piece of road I happened to snap a valve spring. I have always attributed this incident to the roughness of the road, as the spring broke just as the car went into a deep rut. I was puzzled for a time, and was just going to throw the broken spring away in disgust, when a thought struck me that by inserting a washer between the two pieces of broken spring I might be able to make it work. I tried the scheme, and to my great delight found that the engine ran along as well with the double spring as it did before the accident.

As I was making the repair it struck me that there would have been another way of doing it, in case the spring did not work well when fixed in this manner. I thought of taking a piece of pipe and fitting it to the right length and then placing the washer on top of it, thus using only part of the spring. But as the other plan worked perfectly, I was amply satisfied. I think

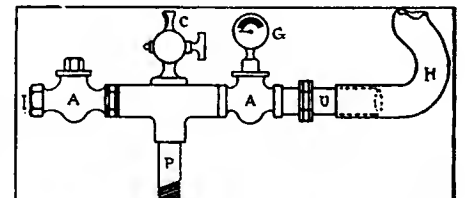

Fig. 2—A tire pump made from the simple fittings common to any plumber's shop

that this is a good lesson not to hastily throw away broken parts.

H. W. W.

New Rochelle, N. Y.



# My Ideal 1912 Automobile

## Readers' Conceptions of What Next Year's Car Should Be

### Curves for \$350

Editor THE AUTOMOBILE:

My idea of what a low-priced car should be will be found in the sketch enclosed (Fig. 1) and the added description.

Curves, all curves you will notice; late investigations have shown just how great are the losses in power on present models because of the want of curves. The windshield is not an addition, but forms a part of the machine. The door when swung open swings a part of the windshield with it to permit easy ingress to the car. There is room for three people, the operator sitting in the middle. The reason for this is that springs, to permit easy riding, must be very soft. Under these conditions, for the driver sitting to one side, when alone, is to have a lopsided machine; further, it is best because symmetrical, other things being equal.

Mudguards and top are put in position when needed, a further reduction in wind resistance; and, for another thing, there is no good reason to keep an umbrella over one's head because it may rain some day. The rear part of the car, all enclosed, provides space to pack spare tires, top and mudguards, and leaves the care more sightly.

A single-cylinder engine of 4 1-2 x 6, giving a maximum speed of 40 miles per hour, which I think is sufficient. Since two horses cannot run faster than one, the additional cylinders of a 4-cylinder engine add to complication, but not to power or better service. A single chain, enclosed against dust; planetary transmission controlled by two interconnected pedals (high and low), for the right foot to manipulate; for the left foot, the transmission brake, also the spark control, arranged in a curved slot and self-locking, should be installed. The low speeds (when hampered by traffic) are had by coasting, after the manner of motorcycles; the clutch is left in, and by throwing the left foot to the extreme left against a spring the fuel and spark are cut off, the car coasting.

The fuel control is located on a sector beneath the steering wheel. There is no carbureter, generator or injector, nor a throttle; I do not think it possible to devise an automatic carbureter (the very great number offered to the public alone will support my contention); therefore I rely on hand control, doing away with the most troublesome part altogether. The throttle serves to cut down the efficiency of the engine to a very great extent, and

speed control by spark advance and coasting I believe more desirable.

The entire upper part of the car is taken up by two tanks, one containing kerosene, 7 gallons for fuel, and 3 gallons of water. The other 1 1-2 gallons of gasoline for starting duty, and 1-2 gallon of oil. No pressure, only gravity required. High-tension ignition by battery and three plugs.

The radiators are hidden in the ventilators on each side, two finned tubes in each. The entire front of the car is open to admit the air freely. The car is 43 inches high, 53 inches at the windshield, and 64 inches with the canopy. Wheelbase, 80 inches; tread, 56 inches. The springs in this drawing are made to yield to all loads alike, and are not visible from the outside. I would not mention this, but it might be thought a defective drawing otherwise.

It should sell for not more than \$350.  
New York City. P. G. TISMER.

### Idea of \$1,500 Car

Editor THE AUTOMOBILE:

Seeing that you ask the readers of your magazine to send in a description of their ideal 1912 car, I am sending mine.

My 1912 car would have a 22-horsepower, 4-cylinder motor of the T-head type, cast en bloc. It should have a bore of 3 3-8 inches and 4 1-2-inch stroke. All valves should be enclosed in a dustproof cover. The ignition should be of the Bosch dual system. Lubrication of the splash type. The carbureter should be of the float-feed type, with an adjustment on the dash.

The clutch should be of the mutiple-disc type and run in oil. It should be housed with the gearset, which should be placed amidships.

The transmission should be selective type, with three speeds forward and one reverse.

The drive should be by shaft with two universal joints, to a full floating rear axle. The front axle should be of the I-beam type with large steering knuckles.

The frame should be underslung and inswept in front, because the underslung frame makes the car safer and makes it possible to have the car look better. The insweep in front is to give the car a short turning radius. The springs should be long, flat, semi-elliptic, with shock absorbers on the front and rear.

Tires should be 36 x 4-inch front and rear, on Firestone demountable rims. Wheel base should be 106 inches.

Control levers should be on the right side; there should be a foot accelerator, and pedals should be standard. The steering wheel should be 18 inches in diameter.

The body should be of the two-passenger torpedo type, with the levers on the outside, and on the rear deck there should be placed the gasoline tank and the spare tire.

Equipment should consist of a top and cover, windshield, speedometer, three electric lamps, two headlights and gas tank, the headlights to be lit by a flash auto-lighter; electric horn, storage battery and one extra rim.

Price should be about \$1,500.  
Walton, Pa. X. Y. X.

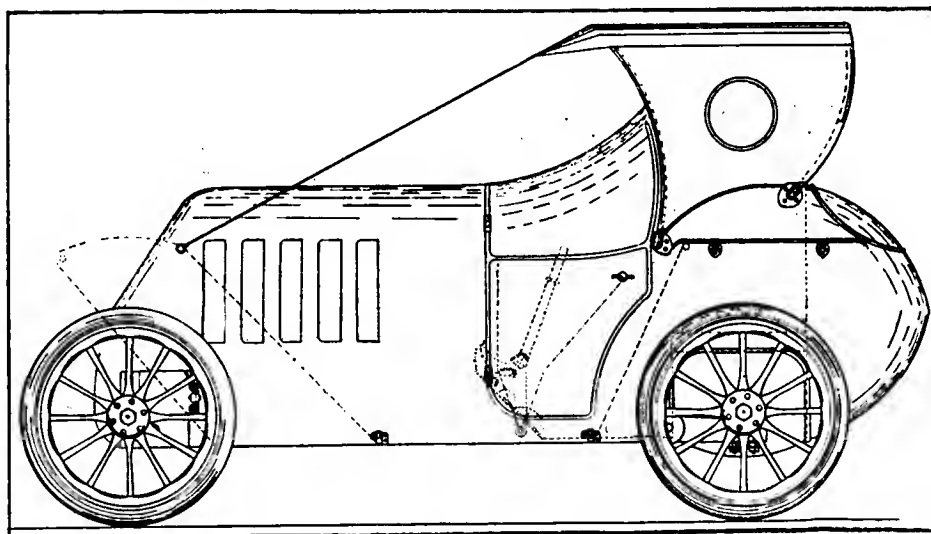

Fig. 1—Illustrating the body desired by a reader at a cost of \$350

# Systematic Handling of Car Repairs

**S**YSTEM, while it may seem complicated at the time of its first introduction, soon proves that it makes things simpler than they were before it took effect. The gain in time and labor by the use of a suitable system is hardly to be overestimated; or is the use of the system itself exaggerated but in very rare instances. In the automobile repair business, this latest branch of the machine trade, system has but recently been introduced, but al-

DATE		CAR AND EQUIPMENT	PRICE	DATE	LABOR	PRICE
		CAR Abbott Detroit	1500	9/15/11	Repairs	57 25
		TOP	75			
		SPEEDO	15			
		SPEEDO METER	45			
		FRESH-O TANK				
		OTHER EQUIPMENT				
		less 'all. on acc.	1540			
		Less car	570			
		Commission	75			
		net	905			
		TOTAL				

Fig. 1—Record of a car, showing the total amount paid by the user of a car, including repairs

intended for, what territory it is to work in, or the like; or, if the car sold is a second-hand one, some confidential notes of interest to the buyer, but charily guarded by the vender, may find their place under that innocent heading Remarks.

The prices given on the reverse side of the card, Fig. 1, for some equipment bought with the car are, of course, fictitious, but they illustrate the manner of keeping a simple yet efficient account of every car sold. In

ready have its advantages made themselves felt. Increased efficiency and consequently greater economy in material and labor are the consequences of a live system applied in these quarters.

In the following is given a description of the card index system used by one of the New York automobile selling concerns, the Abbott-Detroit Motor Company, 1670 Broadway, whose repair department is located a short distance from the store. This concern handles the Abbott-Detroit and Regal products in the Metropolitan district. The system used is simple, consisting of but two small cards, both of which are 5 by 8 inches. One is used on both sides.

The principal card, Figs. 1 and 3, is always kept at the office of the company and is printed on both sides, the front being illustrated in Fig. 3 and the rear in Fig. 1. On the front are entered, besides the make of the car, the buyer, the date of the sale and the name of the salesman who closed the transaction. In case of a used car being traded in the make and allowance made for it are stated, and the salesman's commission, which must, like the preceding figure, be deducted from the selling price of the car, is given on the same line. In case the automobile is insured the details of this fact are given, including the amount the machine is insured for, the price of the policy paid and the date when this has been done. Half the card is left over for remarks of some nature or other, as, for instance, what service the car sold is

the instance shown in the illustration the selling price is \$1,540.45, from which must be deducted the allowance for the old car traded in, which is \$570, as well as the salesman's commission on the deal, amounting to \$75. This leaves a net selling price of \$905.45.

The right-hand side of the card in Fig. 1 is reserved to contain the account of the car's history after its sale so far as the company is concerned in this matter. The first item has been entered on September 15, amounting to \$57.25 for repairs. If reference is made to Fig. 2, the repair and material order of the repair department of the company, it will be seen what items have gone to make up this \$57.25, as well as in what way the repair department is run.

A. G. Jones, buyer and owner of the car named on the sheet, had obviously met with a collision, as is indicated by the nature of the repairs ordered when he handed the automobile over to the company. He asked for a new steering knuckle to be fitted,

as well as for a pair of headlights to be installed on his car. This shows that some cards tell a good deal to the man who knows. Besides there is little doubt but that this was Mr. Jones' first car and that he tinkered with it as well as he could; hence the spoiled valve adjustments, while the disordered transmission gear tells of a tvro-like treatment of the car.

In the repair shop the work was speedily executed. Assuming the steering

ABBOTT-DETROIT MOTOR CO.						
REPAIR AND MATERIAL ORDER						
Name <i>Mr. A. G. Jones</i>			NEW YORK <i>Sept. 15, 1911</i>			
Vehicle <i>Abbott Detroit</i>			No. <i>947</i>		Model <i>B. Touring</i>	
WORK TO BE PERFORMED						
<i>Install new steering knuckle + headlights, look over timing of valves; also see transmission for adjust</i>						
REQ. NO.	PART NO.	MATERIAL USED	PRICE	EXTENSION	TOTAL	
<i>1206</i>	<i>543</i>	<i>Steering knuckle</i>	<i>11 26</i>			
<i>3477/a</i>	<i>3182</i>	<i>Headlights (2) + brackets</i>	<i>16 67</i>			
		<i>Inspecting valve timing + adjust nuts</i>	<i>6 29</i>			
		<i>Inspecting + repairing transmission gears</i>	<i>19 93</i>			
Time		Hours <i>Eight</i>	Workman <i>Wilson</i>	Price	TOTAL <i>57.25</i>	

Fig. 2—Repair and material order, giving detailed figures as to value of repair work done

*Abbott - Detroit*

HISTORY OF CAR			
TO WHOM SOLD	<i>Mr. A. G. Jones</i>	DATE	<i>Jan 26-11</i>
ALLOWANCE ON 2ND HAND CAR AND MAKE	<i>\$570</i>	SALESMAN	<i>Browning</i>
DATE INSURED	AMT. INS. FOR	DATE INS. CANCELLED	TOTAL INS. COST
REMARKS			

Fig. 3—Sales record of car, containing exact data and remarks on transaction between automobile seller and buyer

knuckle to be the part No. 593 on the Model B touring car, then this number is entered under the heading Parts No., while 1206 is the registration number of the individual part fitted to the car and under which it was kept in the shop. Likewise headlights bear the part No. 3182, but the two particular lights fitted to Mr. Jones' car are numbered 3477 and 3478, respectively, the bracket being kept together with the lamp.

Remembering that charges on the sheet illustrated are not the same as those made in reality, let us assume that the steering knuckle is valued at \$11.36 and the two headlights at \$16.67, which prices are entered under the heading so marked. Under Extension, Fig. 2, on a repair sheet are generally charged the repairs of parts covered by a guarantee while it lasts, but made after it expires. Inspecting and adjusting the timing of valves were charged to Mr. Jones at \$6.29, while the work done on the change-speed gearset cost him \$19.93. Adding to these charges the wages paid to the workman who executed the job, the total bill of \$57.25 is arrived at.

The principal cards are kept in alphabetical order, while the repair cards, Fig. 2, one being filled out in every case of a repair job, may be either filed under the car numbers or together with the principal cards. In all cases, however, all the cards are kept

in the office after the repairs have been finished. The principal cards, Figs. 1 and 3, of course, never leave the office, while the blanks for the repair orders, Fig. 2, are kept in the shop, filled out by the superintendent of the repair department and then handed over to the office.

The particular system above described is used, with some minor variations, by many other concerns besides the one named and has been found to be effective enough by those who have introduced it.

—

CAREFUL SUPERVISION WILL SURELY ADD TO THE LIFE OF A CAR—  
It can never be said that a car is in good condition if it is allowed to leave the garage with the tire casings hacked to pieces or with deep cuts appearing on the surface. One of the greatest causes for the rapid deterioration of tires is the fact that water will work through the cuts and rot the fabric. This will eventually lead to a burst which could easily have been prevented with a little energy and foresight. In the points mentioned, as well as in all the other details which will present themselves at different times to the car owner and driver, a careful supervision will be rewarded by a prolongation of the life of the car and increased comfort in driving.

## Calendar of Coming Events

**Shows**

- Jan. 2-11.....New York City, Hotel Astor, Importers' Salon.
- Jan. 6-13.....New York City, Madison Square Garden, Twelfth Annual Show, Pleasure Car Division, Automobile Board of Trade.
- Jan. 6-20.....New York City, Madison Square Garden, Annual Show, Motor and Accessory Manufacturers.
- Jan. 10-17.....New York City, Grand Central Palace, Twelfth Annual Show, National Association of Automobile Manufacturers; also Motor and Accessory Manufacturers.
- Jan. 15-20.....New York City, Madison Square Garden, Twelfth Annual Show, Commercial Division, Automobile Board of Trade.
- Jan. 22-28.....Providence, R. I., Providence State Armory, Rhode Island Licensed Automobile Dealers' Association, Automobile and Accessories Show.
- Jan. 27-Feb. 10....Chicago Coliseum, Eleventh Annual Automobile Show under the auspices of the National Association of Automobile Manufacturers. Pleasure cars, first week. Commercial vehicles, second week.
- Feb. 12-17.....Kansas City, Mo., Annual Show, Combined Association of Motor Car Dealers.
- Feb. 14-17.....Grand Rapids, Mich., Third Annual Show.
- Feb. 17-24.....Newark, N. J., Fifth Annual Automobile Show, New Jersey Automobile Exhibition Company, First Regiment Armory.
- Feb. 17-24.....Minneapolis, Minn., National Guard Armory and Coliseum, Annual Automobile Show, Minneapolis Automobile Show Association.
- Feb. 19-24.....Hartford, Conn., Annual Show, Automobile Club of Hartford, State Armory.
- Week Feb. 22.....Cincinnati, O., Annual Show, Cincinnati Automobile Dealers' Association.
- March 2-9.....Boston, Mass., Tenth Annual Show, Boston Automobile Dealers' Association, Inc.

**Meetings, Etc.**

- Nov. 20-24.....Richmond, Va., First American Road Congress, under auspices of American Association for Highway Improvement.
  - Nov. 22.....Road Users' Day, under direction of Touring Club of America.
  - Jan. 18-20.....New York City, Annual Meeting of the Society of Automobile Engineers.
- Race Meets, Hill-Climbs, Etc.**
- Oct. 14 (to 26)....New York City, Start of the Annual Glidden Tour, en route for Jacksonville, Fla.
  - Oct. 28.....Brooklyn, N. Y., Sealed Road Handicap for Schimpf Trophy, Long Island Automobile Club.
  - Oct. 30.....Minneapolis, Minn., Hill Climb.
  - Oct. 27-Nov. 3....Chicago, Ill., Thousand-Mile Reliability Run, Chicago Motor Club.
  - Oct. 30.....Harrisburg, Pa., Economy Run, Motor Club of Harrisburg.
  - Oct. 31.....Shreveport, La., Track Races, Shreveport Automobile Club.
  - Nov. 2-4.....Philadelphia Reliability Run, Quaker City Motor Club.
  - Nov. 3.....Newark, N. J., Reliability Run, Newark Motor Club.
  - Nov. 3.....Newark, N. J., 125-mile Automobile Endurance Run, Newark, Star.
  - Nov. 3-4.....Columbia, S. C., Track Races, Automobile Club of Columbia.
  - Nov. 4-6.....Los Angeles-Phoenix Road Race, Maricopa Auto Club.
  - Nov. 9.....Phoenix, Ariz., Track Races, Maricopa Automobile Club.
  - Nov. 9, 10, 12....San Antonio, Tex., Track Races, San Antonio Auto Club.
  - Nov. 27.....Savannah, Ga., Vanderbilt Cup Race, Savannah Automobile Club.
  - Nov. 30.....Los Angeles, Cal., Track Races, Motordrome.
  - Nov. 30.....Savannah, Ga., Grand Prize Race, Savannah Automobile Club.
  - Dec. 25-26.....Los Angeles, Cal., Track Races, Motordrome.
- Foreign**
- Nov. 3-11.....London, Eng., Olympia Show.

# THE AUTOMOBILE

Vol. XXV

Thursday, October 26, 1911

No. 17

## THE CLASS JOURNAL COMPANY

H. M. SWETLAND, President

CONDE NAST, Vice-President and General Manager

E. M. COREY, Secretary and Treasurer

231-241 West 39th Street, New York City

Cable Address - - - - - Autoland, New York  
 Long Distance Telephone - - - - - 2046 Bryant, New York

### SUBSCRIPTION RATES

United States and Mexico - - - - - One Year, \$3.00  
 Other Countries in Postal Union, including Canada - - - - - One Year, 5.00  
 To Subscribers—Do not send money by ordinary mail. Remit by Draft,  
 Post-Office or Express Money Order, or Register your letter.

Entered at New York, N. Y., as second-class matter.

The Automobile is a consolidation of The Automobile (monthly) and the Motor  
 Review (weekly), May, 1902, Dealer and Repairman (monthly), October, 1902,  
 and the Automobile Magazine (monthly), July, 1907.

## Does It Boost Good Roads?

THE Glidden tour was taken South to boost the good roads cause. Does it boost the good roads movement and does it boost the automobile business to take seventy cars through a country in which there are over thirty streams that have to be forded? A tour went over this same route two years ago and these same fords were in existence then; they had to be forded then, but fortunately the weather was, and had been, dry at that time and the water was low. In two years there has been plenty of time to build bridges over some of these fords, in fact over all of them. It should not require an annual demonstration of running an automobile through water and mud, or having it towed by oxen or horses or mules, to impress on the populace the necessity of good roads. The question then arises, Is the present tour worth while from a good roads point of view? This remains to be seen. If immediate work is not begun bridging these fords and getting stone road material to the quagmire road sections then it is not worth while. What the section of road from Natural Bridge to Martinsville needs is immediate action rather than any more tours. The experiences of the past week with the Gliddenites is not a good advertisement to those Southern States. It is going to repel touring from that locality rather than encourage it. You can talk of enthusiasm and receptions, but if you have not roads automobiling is not worth while. The roads must be built. The people have known for several years just how bad these roads are when it rains. There is not any use of advertising the fact any further; it would have been better without this recent exploitation. Work is needed.

Much work has been done on these roads within the last three years, but still they are impassable when it comes to the worst. A chain is but the strength of its weakest link and a road is but as good as its worst spot. One old road builder defined a good road as being one that is good in bad weather. This is a good definition. Any dirt road can be good in fine weather; any clay road can be all right when there are not any rains. What

better roads could be desired than a dragged gumbo road in dry summer months? but with all of these dry-weather roads it is the same story of impassability in rainy periods. What America needs is the road that is good in bad weather. This is the kind of road that the East is building and this is the kind of road that must be built in the South, and in the Middle West gumbo and black-soil districts. It does not call for so-called automobile tours to let the people know this. This fact is already known. Tours are excellent things if some actual good is achieved as the tour goes along. It would pay the South to issue bonds and build a good stone road into the heart of its territory and then run a tour over it in the rainy season to demonstrate to the entire nation that it has good roads—roads that are good in bad weather.

\* \* \*

## Introducing Motor Trucks

IN these days, when many dealers in pleasure cars in different sections of the country are taking on a line of commercial cars, it is imperative that such dealers give some study to the task they have undertaken. They imagine that because they have been successful in selling pleasure cars they cannot but be successful with commercial vehicles. This does not necessarily follow. A commercial car is a business investment, whereas many pleasure cars are purchased for pleasure and outing purposes. The work of introducing the commercial car is a big task. In the first place the pleasure car dealer is ignorant of many factors entering into the situation. He is ignorant of the details of his truck construction; he is ignorant of the sphere of freight transportation within big cities; he is ignorant of the problem of commercial vehicle maintenance; he is ignorant of the troubles with the truck driver; he is ignorant of the ins and outs of the teamster situation in the city streets and depot yards; in a word, there are ten or more important factors that must be carefully studied before the pleasure car dealer is in a good position to take the truck matter sensibly in hand.

The truck is in many cases a good engineering job. The strength of the axles, springs and wheels is adequate; the body facilities meet with all requirements, and the design of motor or gearset is satisfactory for the present. These are but small items in the big problems of handling trucks. The first big problem is the selection of a proper system of trucks or delivery wagons for the needs of the buyer. It is folly to sell a mercantile store 3-ton trucks if the demands of their business are such that 1-ton trucks are best suited for the work. It is poor policy for the salesman to make a sale where he himself feels that his truck is not best suited for the work. It would be better in the long run not to make such sales. Some truck concerns have been conscientious in this matter and when they did not have types of trucks best suited to the needs of many of their customers they took the matter in hand and brought out new models of load-carrying capacity to suit the needs of the buyers in question. This is good truck policy and should be imitated by others. A dealer does not lose much in the long run when he looks after the interests of his buyers in this matter of truck selection. Some dealers may argue that it is not their sphere to say exactly what load capacity or type of truck is best adapted to the particular needs.

The dealer should know better than the buyer. If the dealer does not know then he should go out and study the problem. It is a certainty that the buyer does not know. The motor truck is an untried quantity to him and he will be apt to draw comparisons between it and his horse-drawn systems. Comparisons are dangerous in this field, because the buyer is ignorant of the abilities of the truck; he will underestimate certain qualities of it and may overestimate others. He cannot properly compare; he does not know enough about the trucks to make such comparisons. Here is where the field of the salesman comes in. The salesman must get out of the salesman's room. His work is not one of talking mechanical constructions or elucidating on engineering problems; his is a duty of meeting conditions front to front. He must study the problems of freight delivery in the congested zones of cities and also in the suburban and semi-suburban districts. He must study the fields best filled by gasoline types of machines and he must also study the fields for which the electric is specially qualified. This is not any child's play; it is real labor—labor that

can only be accomplished by the sweat of the brow.

But the truck dealer has more problems to solve. He has to solve the question of the driver and other workers on the truck. The driver of the horse-drawn vehicle has set his pace to suit horse-drawn traffic; he is not working on a pace for motor-driven vehicles. Consequently the efficiency of the truck is held back by the horse-pace of the driver or other truck attendants. This field must be cleaned up. The horse driver, satisfied to sit and wait for two hours while a big load of small packages is being put on, is a stumbling block to truck introduction. Where small packages are involved a crate system is advisable. It is more expensive to keep a big truck idle for two hours during a slow loading process than to keep a horse-drawn truck idle during the same period. In two hours the motor truck can travel sixteen miles, but the horse team could not make over 4 or 6 miles. New facilities for loading and unloading must be worked up, otherwise the truck will be held back by the old horse-order of things. The driver must be speeded up; otherwise the efficiency of motor delivery will be held back.

## Chairman Butler Killed on Glidden

TIFTON, GA., Oct. 25—(Special Telegram)—Samuel M. Butler, Chairman of the Contest Board of the American Automobile Association, was instantly killed this morning, and P. B. Walker, Referee of the Glidden Tour of 1911, and Mrs. Walker were seriously injured when the Cunningham pacemaking car in which the official party was riding broke a steering knuckle and plunged off the road into an adjoining field. Mr. Butler was caught under the tonneau when the crash came and was crushed to death in the twinkling of an eye. Referee Walker was badly shaken up and injured internally, while Mrs. Walker suffered a broken arm. Both are in a Tifton hospital.

At the time the accident occurred the car was going at about 35 miles per hour over a very good road. While the cause of the breakage is not definitely known, it was in all probability due to crystallization of the knuckle while the car was being subjected to the knocking and pounding on the terrible roads in Southern Virginia.

It was at first stated unofficially by THE AUTOMOBILE representative that owing to the distressing accident the tour would be abandoned at Tifton. This place, according to the route book of the Glidden tour is 41.9 miles from Cordele, the over-night stop. Later it was announced that the run would be continued on neutralized running time.

Samuel McKnight Butler was born Sept. 13, 1866, and was therefore 45 years old. He is survived by a widow and two children—a boy of 18 and a girl of 16. Their home is on Carlton street, Brooklyn, N. Y.

Mr. Butler was first assistant secretary and then secretary of the Automobile Club of America, holding the latter position at the time of the formation of the American Automobile Association, in the organization of which he was largely instrumental. He retained his position as Secretary of the A. C. A., until he assumed the chairmanship of the Contest

Board of the American Automobile Association in December, 1909. He was also at one time secretary of the Aero Club of America, and made quite a number of ascensions during his incumbency of the office. During the Spanish-American War, Mr. Butler served with credit in the Signal Corps of the United States Army.

### S. A. E. Headquarters in London

Interest in the approaching European tour of the Society of Automobile Engineers is growing. As previously announced the headquarters in London will be at the St. Ermin's Hotel, St. James' Park, London, S. W., near Westminster Abbey and the Houses of Parliament, and within a short walk of Whitehall, Pall Mall, Piccadilly, the Strand, and other leading thoroughfares of the English metropolis. The hotel is the headquarters in London of the Motor Union of Great Britain and Ireland.

The hotel management has officially quoted a price of from 6 shillings and 6 pence (\$1.75) per day up for each person according to size and position of room selected. This price includes lights, attendance and bath and table d'hote breakfast. Rooms with private baths can be secured from 9 shillings (\$2.25) per day up per person without meals. Suites of two rooms and bath (without breakfast), can be had from 1 guinea (\$5.25) per day, upwards.

The St. Ermin's Hotel is connected by a private corridor to St. James' Park subway station, whence trains run direct to the automobile exhibition at Olympia. The Cunard Steamship Company has furnished a neat baggage label for the special use of the S. A. E. members.

The party which will sail on the *Mauritania* on November 1 will include forty-three persons. Sixteen members will join the party abroad. A group photograph will be taken before the start.



The late Samuel M. Butler.



## Big Purses for Savannah Races

SAVANNAH, GA., Oct. 23—With the Thanksgiving race week more than a month away, interest in the approaching contests is at fever heat here. On Wednesday morning last the advance sale of box and grandstand seats for the two days' races was opened, and, in addition to 75 boxes, several hundred reserved seats in the stand were disposed of. Mayor George W. Tiedeman was accorded the privilege of buying the first box. The prices of tickets are the same as last year. Box seats for two days, \$50; grandstand seats for two days, \$3; general admission, \$1 each day. Parking spaces will cost \$25 or \$50, according to location.

The large number of reservations being filed at the local hotels indicates that the crowds that will assemble here during the last week of November will exceed in size even the record-breaking gatherings of former Grand Prix weeks.

The Lozier Company has announced its intention of entering two cars in each of the big races—the Grand Prix and the Vanderbilt—but has not as yet nominated the drivers.

The prize list is growing daily. Besides the Savannah Automobile Club's \$12,500 and the Remy Company's \$4,250, the Findeisen & Kropf Company, maker of the Rayfield carbureter, has hung up \$2,500, and the Bosch Magneto Company has come forward with cash offers aggregating \$1,550.

### Garford Tourists on Santa Fé Trail

OMAHA, NEB., Oct. 21—With their trip of 4,200 miles almost half completed the tourists following the "Trail to Sunset" are spending to-day in this city and Monday morning they will turn southward to strike the Santa Fé trail at Kansas City, entering on that famous highway next Wednesday to follow it over 800 miles into the great Southwest.

The four Garford touring cars which are carrying the passengers as well as the "prairie schooner" which makes the fifth car of the automobile train and in which are the hand baggage and extra tire equipment have all made the trip so far in perfect condition.

The reception accorded the tourists in Iowa during the last four days of the week just closed surpassed anything they have so far experienced. From Davenport to Omaha they followed the "River to River Road," a smooth, straight highway on which the Hawkeye motorists have been laboring for months. The tourists crossed the Mississippi at Davenport Tuesday night.

Next Sunday's stop will be at Dodge City, Kan. As towns of any size and consequently hotels of the better class are far apart in that part of the country the longest single day's run of the whole tour will be made next Saturday. This will be from Hutchinson to Dodge City, a distance of approximately 154 miles, the stop for lunch probably being made at Larned.

When the tour reaches Hutchinson, Kan., next Friday afternoon, it will have covered exactly half of the 4,200 miles of its schedule.

### Floral Parade Features Lincoln's German Day

LINCOLN, NEB., Oct. 23—One of the features of the German day celebration here was an automobile floral parade, in which fifty beautifully decorated automobiles took part. The parade brought a large number of people from out of the city, being something new here.

The first prize was won by Miller & Paine, the car being decorated in brown and red autumn leaves, four gilt pillars supporting a canopy, above which in a lotus flower was a little girl.

Mrs. Gillen and Mrs. Boney won second prize with a car decorated in roses and green leaves. Above the tonneau a rose arbor was erected, lattice work being covered with rose buds.

S. S. Shean took third with a simple gold and white car. H. E. Kooch, fourth, and O. E. Houck, fifth.

The Elks were awarded first prize in the lodge contest, the car being decorated with chrysanthemums on a white background, and having two elks at rest with a third standing.

The Eagles took second for lodges, with red, green and white decorations, eagles on brackets ahead of car, large white eagle above, with group of birds just over windshield.

### To Fight Alabama's New Automobile Law

MONTGOMERY, ALA., Oct. 21—The new automobile law of Alabama will be attacked. The allegation is that the law is unconstitutional and the State may be forced to return the license fees collected from the owners of automobiles.

In the act there is a provision that the fee or license collected shall be in lieu of all other privilege licenses which may be exacted by any municipality or county, and the allegation is that this is in direct conflict with the Constitution of Alabama.

As the automobile law now is, the license fee is paid over to the State and a municipality or county cannot impose a tax or license, but the State divides up with the different municipalities and counties.

The flaw was picked out by R. G. Arrinton, an attorney of Montgomery, and also a well-known automobile enthusiast. It is probable that steps will be taken at once that will place the case before the Supreme Court so that a decision can be rendered before time to collect the auto tax for next year.

The legality of the law affects many owners of automobiles in Alabama. At the present time a tax is being collected by the Secretary of State and each machine is numbered consecutively.

### Velie Officials Entertain Dealers

MOLINE, ILL., Oct. 23—Officials of the Velie Motor Vehicle Company were hosts last week to forty-five representatives of the Velie throughout the country who were called into the home plant to inspect 1912 models and have improvements and new conditions pointed out. The visiting dealers were addressed by Chief Engineer C. B. Rose, Sales Manager C. H. Lloyd and Assistant Sales Manager C. P. Hatter. The following officers and employees of the Velie plant entertained the visitors: President, W. L. Velie; secretary, L. M. Fuller; chief engineer, C. B. Rose; sales manager, C. H. Lloyd; assistant sales manager, C. P. Hatter; Henry T. Wheelock, in charge of truck sales; Messrs. Bryant Thompson, Brink, Soner, Ramsay, Kennedy, Froelich and Ward.

The following are the dealers registered: Messrs. Taylor, Memphis, Tenn.; Scouten, Nashville; Elliott, Nashville; Banta, Spokane; Duc Luce, Chicago; Beharall, Lowell, Mass.; Wylie, Kansas City; Johnson, Essex, Vt.; Bornstein, Boston; Lanc. Cormley and Steinert, Pittsburgh; Morse, Knoxville; Glynn, San Francisco; Benton, Los Angeles; Dixon, Buffalo; Davis David, Philadelphia; Garland, New York City; Kerr, Syracuse, N. Y.; Schmidt, Harrisburg, Pa.; Varrell, Gloversville, N. Y.; Burns, St. Louis; Wetherby, Syracuse; Reed, Wichita, Kan.; Marrill, Louisville, Ky.; Lindsay, Omaha; Snell, Attleboro, Mass.; Geer, Minn.; Smith, Hibbing, Minn.; Titus, Miles City, Mont.; Harrington, Sleighton; Roller, St. Paul; Highshoe, McLean; Hogan, Alvedo, Ill.; Heiserman, Albia, Ia.; Ketchan, Farmington; Kelly, Farmington; Minturn, Winterset, Ia.; De Jarnette, Omaha; Randall, Oklahoma City.

## News of the Week in Detroit

**D**ETROIT, MICH., Oct. 23—The activity that prevailed in Detroit factories earlier in the month continues, with no sign of abatement. Many of the plants are working both day and night shifts and still are behind orders in some instances. So there is every reason to believe that the business for the month will meet all expectations.

The Chalmers Motor Company is planning the erection of a new warehouse at its plant in the very near future. It will be so arranged that cars can be loaded for shipment directly from the warehouse. The plant is running full capacity.

The Chalmers annual technical convention began last week, with a good attendance. The convention will be held in three divisions, the second division convening to-day and the third, Oct. 30. Those in attendance last week included technical men from the Eastern cities and from Michigan, Ohio and Indiana. Nearly an entire day was spent in disassembling and studying the chassis of the Chalmers "36." Talks were given by George W. Dunham, vice-president and consulting engineer of the company; A. B. Hanson and R. O. Gill, of the service division, and C. C. Cross, head of the inspection department. Particular attention was given to the Chalmers standardization methods. These conventions are for the benefit of representatives of the service divisions of Chalmers dealers and Chalmers road men.

Three delegations representing outside motor car manufacturers, including managers and their engineering staffs, were among the visitors to the Cadillac plant last week. They came for the express purpose of studying the Cadillac electric starting and lighting process. The Metzger Motor Car Company entertained a dozen or more dealers from various parts of the country and State during the week.

The chief topic of discussion in local motor car circles the past week has been the report of the tax commission appointed by Gov. Osborn to make an inquiry into the tax question. The report, which was made public a few days ago, confirms earlier statements to the effect that the motor industry would come in for a good deal of consideration. That an attempt will be made by the State to force the manufacturers to pay more taxes was made clear by the governor in an address before the members of the Detroit Board of Commerce at a luncheon in the Hotel Cadillac last Thursday, when he said:

"There is to my mind no good reason why those corporations of Michigan which bear inadequately their burden of taxation should not be brought to a point of correction. The automobile industry in Detroit and Michigan is one that should be aided and encouraged in every reasonable manner. But there is not one automobile manufacturer who would care to be placed in the charitable class, or who would contend that \$1.40 per thousand is enough taxation, when the railroads are paying \$20.55; residences in cities and villages, \$14.50; farms, \$10; electric railroads, power, heat, light and gas companies, \$7, and manufacturing corporations, \$5.30. This inequality and unfairness is intolerable."

The figures quoted by the governor were taken from the tax commission's report. With reference to the automobile industry in Michigan, the commission shows that manufacturers of motor cars and automobile parts in the State reported a total net income of \$14,508,529, net income, exclusive of all interest, \$13,428,053; capital stock, \$29,192,079; indebtedness, \$47,239,044; taxes paid in 1909, \$185,000. The report goes on to say:

"The net income, exclusive of interest, capitalized at 10 per cent., gives the value of the stockholders' equities as \$134,280,530 which, divided into the taxes paid for these industries, gave a rate of \$1.40 on the thousand. If we add the indebtedness, the value of the corporate business is \$181,000,000, which paid taxes

at the rate of \$1.05 per thousand, or 1.14 per cent. of the net income.

"A careful perusal of the methods employed and the results produced in these figures demonstrates the existence in Michigan of a large amount of property grossly undertaxed, as compared with other property."

In another part of its report, the commission says:

"It will be shown that too much attention has been centered on the taxation of farm property and railroads, while the automobile manufacturing industry seems to have been sadly neglected, as viewed from a taxation standpoint."

In response to many requests from various interests, the commission has arranged for public hearings on their report. These will begin at Lansing in a day or two, and it is expected that the motor car makers will be well represented.

In addition to the condemnation proceedings instituted in the recorder's court a few days ago, the Herreshoff Motor Company, which is building a factory on Woodward avenue, in a fashionable residence neighborhood, now has an injunction suit on its hands. Judge Donovan, of the Wayne circuit court, has issued an order, on the petition of several residents of the neighborhood, directing the company to show cause why an injunction should not issue.

The 3-ton Packard truck, which was brought back to Detroit a few days ago after its transcontinental run from New York to San Francisco, leaves to-day on an exhibition tour that will cover a period of several weeks. It goes first to Toledo, O. Other cities to be visited are Cleveland, Rochester, Syracuse, Albany, Boston, Providence, Hartford, Bridgeport and New York.

The United Motor Detroit Company is well pleased with the showing made by the Maxwell Messenger in its 120-hour non-stop run, which ended last Tuesday. The little 16-horsepower car covered a total of 2,060 miles, consumed 91 gallons of gasoline, an average of 22 1-2 miles per gallon; 82 pints of oil and two quarts of water.

Weather permitting, the Wolverine Automobile Club will hold the second of its under-sealed-orders sociability runs next Sunday. The Detroit *Saturday Night* offers a silver trophy to the member coming nearest to the time of the pathfinding car. The club is making arrangements for a big social evening Nov. 4. It is also planning to get out a club publication. The first number will make its appearance early next month.

### Tire Men Gather in Metropolis

An important gathering of tire men was held at the Hotel Astor in New York last Sunday, when the United States Tire Company called together all its branch managers and salesmen in the Central and Eastern Districts to discuss trade policies for the coming year. About 150 representatives of the company were present, among whom were: J. M. Gilbert, general manager; J. D. Anderson, general sales manager; A. I. Philip, manager central district; O. S. Tweedy, manager eastern district, and William MacMahon, chairman of the factory committee.

The meeting was presided over by Mr. Anderson. General Manager Gilbert made the principal address. He outlined in detail the plans of the organization for taking care of the country's demands during the coming year. Addresses also were made by Messrs. Philip, Tweedy, Anderson and MacMahon.

Following the business session a luncheon was served and the Central District managers and salesmen made a hasty get-away for their homes.

This was the first trade-policy meeting held by the United States Tire Company since its organization.



Universal 3-ton truck in the service of the Concrete Lumber Co., Detroit, Mich.

**SAN FRANCISCO.**—The Velie cars will hereafter be handled in Northern California by the Auto Sales Company.

**SAN FRANCISCO.**—The Olds Motor Works, of Lansing, Mich., has established a branch here, with D. L. Whitford as manager.

**SAN FRANCISCO.**—The Northern California agency for the Selden car has been placed with the Middleton Motor Car Company, of this city.

**SAN FRANCISCO.**—The H. O. Harrison Company, now California distributor of the Peerless and Everitt cars, has taken the agency for the Waverley Electric.

**FRANKLIN, IND.**—It is announced that the Whitesides Motor Truck Company, located here, has leased the buildings formerly occupied by the Safety Shredder Company at Newcastle and will move to that city.

**SAN FRANCISCO.**—Geo. A. Troutt, representing the Lion Motor Car Company, of Detroit, has placed the Northern California agency for the Lion with the Reliance Automobile Company, which also handles the Knox and Detroit electric lines.

**SAN FRANCISCO.**—G. L. Wands has been appointed director of agencies for the Haynes Auto Sales Company, Coast distributor of the Haynes and Krit cars. Chas. Corcoran takes his place as sales manager of the local Haynes branch.

**SAN FRANCISCO.**—The Reo Pacific Company has been appointed distributor of the Premier cars in Northern California and Nevada. Norman de Vaux, manager of the company, also takes over the Reo wholesale business in Southern California.

**INDIANAPOLIS, IND.**—The Central Automobile Company, North Capitol avenue, has taken the agency for the line of electric trucks manufactured by the Walker Vehicle Company, Chicago. The Indianapolis company will distribute the Walker throughout Indiana.

**WILMINGTON, DEL.**—The first automobile ambulance in the State has been placed in service here. It is connected with the Fire Department and is operated by No. 4 Company. The car comprises a Mitchell chassis and a body of the regulation pattern, built by the Bowe Carriage Co., of this city.

**DETROIT, MICH.**—Hugh Chalmers, head of the Chalmers Motor Co., will be one of the speakers for Road Users' day, which will be one of the features of the first American Road Congress, to be held in Richmond, Va., Nov. 20-24. His topic will be "The Forecast of the Automobile Industry."

**SAN FRANCISCO.**—The National agency for Northern California has been annexed by the Howard Automobile Company, Coast distributor of the Buick cars. Carl Christensen, hitherto representative of the National, joins the Howard forces and will remain in charge of the National end of the establishment.

**SAN FRANCISCO.**—The Ford Motor Company, of Detroit, has established a branch house here, to handle Northern California, Nevada and the Hawaiian Islands. The new Ford headquarters will be in a spacious building at Van Ness avenue and Fell street. The branch will be in charge of J. B. Lund, who has been assistant manager of the Ford branch in Seattle.

**KANSAS CITY, Mo.**—At the largest and most enthusiastic meeting that has ever been held the Kansas City Motor Car Dealers' Combined Associations decided to hold a motor car show February 12 to 17.

**DETROIT, MICH.**—M. H. Snyder, of Bozeman, Mont., has been appointed sales manager for the Day Utility Car Co. Mr. Snyder has been a dealer in Bozeman for several years and came here last week to secure the agency for the Day car in the State of Montana.

**DETROIT, MICH.**—The General Motors Co. has found it necessary to seek larger quarters for its general offices and will move from its present location at No. 127 Woodward avenue to the new Boyer-Campbell Building as soon as the latter is completed, occupying practically the whole building with the exception of the ground floor.

**SAN FRANCISCO.**—The local branch of the American Motors Company has been incorporated as the American Motors California Company, with J. I. Handley as president. W. Scott Heywood, a wealthy oil man of California, becomes vice-president and general manager. Marc Bunnell, until now manager of the branch, becomes district sales manager for the Pacific Coast and inter-mountain States.

**NEW YORK CITY.**—H. F. Donaldson has sold his interest in *The Commercial Vehicle* to the United Publishers Corporation, and has tendered his resignation as president and editor of that publication. Mr. Donaldson intends to join the S. A. E. party sailing for England November 1, and while abroad will investigate commercial vehicle conditions in Europe, returning in time for the New York shows in January.

**SOUTH BEND, IND.**—The Fisher Manufacturing Company, of South Bend, has been reorganized with capital stock of \$100,000, and will locate in Toledo, Ohio. The new company will be known as the Electric Auto-Lite Company with A. W. Fisher, of South Bend, president; S. L. Kelly, South Bend, vice-president and general manager; C. O. Miniger, Toledo, secretary and treasurer. The capital stock has been fully paid in and the company expects to move to Toledo immediately.

**TOLEDO, OHIO.**—Among the "fans" who witnessed the world's championship series between the New York Giants and Philadelphia Athletics were the Overland baseball team, composed of men employed in the Willys-Overland plant at Toledo. During the summer a Toledo newspaper conducted a contest for the most popular amateur and semi-professional baseball team in Northern Ohio, and the Overland organization received an overwhelming majority by popular vote. In addition to winning the trip East to witness the series, the Overland team received a cash prize of \$500.

DETROIT, MICH.—The Warren Motor Co., of this city, has been elected a member of the Automobile Board of Trade.

INDIANAPOLIS, IND.—The Fisher-Gibson Company has become the Indiana distributor for the Stearns. This company also represents the Overland, Empire, Stoddard Dayton, Alco and Baker.

NEW YORK CITY—At the regular monthly meeting of the Motor Truck Club on Wednesday, October 25, at 6 p. m., at the Hotel Empire, Broadway and 63rd street, there was an informal dinner which was followed by the regular papers, discussion and business.

MISHAWAKA, IND.—Frank Dean, formerly connected with the Thomas Flyer Company, of Buffalo, N. Y., has been appointed superintendent of the Simplex Motor Car Company, to succeed Joseph Holloway, who has resigned.

DES MOINES, IOWA—The Herring Motor Co., of this city, Iowa agent for the Ford, this week established an agency at Waterloo. The company will be known as the Repass Automobile Company and will handle Fords exclusively.

MONTGOMERY, ALA.—The Chalmers Agency has one of the best exhibits in the machinery hall of the Alabama Exposition now in progress here. It is the only local agency with a large exhibit. There are five cars shown.

NEW YORK CITY—Mr. Chas. A. Ackerman has severed his connection with the F. B. Stearns Company and has accepted a position in the sales department of S. J. Wise & Company, Eastern distributors of the Valveless Amplex car.

DES MOINES, IOWA—Frank Gotch, the world's champion heavyweight wrestler, has closed contracts with the Studebaker Corporation, to handle E-M-F and Flanders cars in Humboldt, Iowa. He also represents the Mitchell there.

INDIANAPOLIS, IND.—From January 1 to October 20 there were 2,623 motor vehicle licenses issued by the city of Indianapolis. During all of 1910 there were 1,850 licenses issued. City Controller Wallace has recommended a new ordinance amending the license fees, fixing the license for runabouts at \$3, for turing cars \$7 and for trucks \$10. All motor vehicles, regardless of size, now pay but \$3 a year.

DETROIT, MICH.—The New Departure Manufacturing Company has installed at its Western Branch, 1016 Ford Building, a measuring machine which is available without cost to the trade in general for close measuring. The machine positively indicates variations of 1-40 of .001 inch, and is a duplicate of the machine used by the company at its factory in Bristol, Conn., in accurately manufacturing gauges used for inspecting New Departure ball bearings.



Effective way in which a Texas motor truck dealer advertised his vehicles

## Automobile Incorporations

### AUTOMOBILES AND PARTS

BUFFALO, N. Y.—Queen City Electric Automobile Co.; capital, \$50,000; to make automobiles. Incorporators: A. C. Towne, C. S. Chamberlain, Moses T. Day.

BUTLER, PA.—Carter Motor Car Corporation; capital, \$50,000; to build motor cars.

CHESTERTOWN, Mo.—Chestertown Automobile & Garage Co.; capital, \$25,000. Incorporators: H. Berge Simmons, A. Parks Rasin, L. Bates Russell.

CHICAGO, ILL.—Karheck Motors Co.; capital, \$50,000; to build automobile engines. Incorporators: E. E. Hartman, A. T. Ewing.

CLEVELANO, OHIO.—Richardson-Neighbors Motor Co.; capital, \$5,000; to sell automobiles. Incorporators: F. E. Richardson, H. F. Neighbors, W. J. Dawley.

DAYTON, OHIO.—Dayton & Troy Automobile Co.; capital, \$10,000. Incorporators: C. E. Emerick, S. S. Faulkner, W. J. Sherer, S. B. Franklin, D. B. Sherer.

DAYTON, OHIO.—Marion Automobile Co.; capital, \$5,000; to sell automobiles as well as accessories. Incorporators: Leslie B. Eaton, Frank W. Penabaker, O. G. Stout, William C. Frizzell, C. L. G. Breene.

DAYTON, OHIO.—Ohio Mercer Sales Co.; capital, \$20,000; to buy and sell automobiles and accessories. Incorporators: Geo. A. Ware, M. E. State, F. P. Chamberlin, B. L. Hull, H. I. Roheson.

LANSING, MICH.—Mechanics Motor Car Co.; capital, \$10,000; to build automobiles.

LEWISBURG, W. VA.—Greenbrier Motor Co.; capital, \$10,000; to sell automobiles, etc. Incorporators: Mason Bell, F. E. Campbell, F. M. Arbuckle, K. M. Snyder, W. E. Hines.

MEMPHIS, TENN.—Noble S. Bruce Auto Co.; capital increased from \$10,000 to \$50,000. Incorporators: J. W. Bruce, C. E. Beloate, Noble S. Bruce, John S. Parker, C. H. Thomas.

MEMPHIS, TENN.—Chickasaw Motor Car Co.; capital, \$25,000; to sell automobiles and conduct a repair business.

MONTCLAIR, N. J.—Frank A. Reeve Co.; capital, \$50,000; to build motor cars. Incorporators: Frank A. Reeve, John A. Butler, David H. Slayback.

NEW YORK CITY.—Colonial Sales Co.; capital, \$10,000; to deal in automobiles and accessories. Incorporators: Everett A. Levy, Louis V. Hansen, Benj. H. Stern.

NEWARK, N. J.—Merchants Motor Car Co.; capital, \$50,000; to build automobiles.

PHILADELPHIA, PA.—Cavac Motor Car Co.; capital, \$50,000; to build automobiles.

TOLEDO, OHIO.—Ford Bros. Auto Sales Co.; to deal in second-hand automobiles. Incorporators: Guy R. Ford, J. R. Ford.

WILMINGTON, DEL.—Union Motor Car Co.; capital, \$25,000; to build automobiles.

### AUTOMOBILE GARAGES; ACCESSORIES

CAMDEN, N. J.—International Airless Tire Co.; capital, \$100,000; to make automobile tires. Incorporators: J. H. Nixon, I. Zimmerman, T. B. Hall.

CLEVELANO, OHIO.—Start-O Co.; capital, \$10,000; to make and sell starters and other accessories. Incorporators: Henry P. Beckenbach, Hubert B. Fuller, E. L. Stoiber, William E. S. Fitzgerald, R. M. Hard.

CLEVELANO, OHIO.—Moore & Rigby Garage and Sales Co.; capital, \$10,000; to conduct a garage and repair business. Incorporators: W. H. Moore, John Moore, Albert V. Rigby, C. F. Magee, C. E. Alden.

DETROIT, MICH.—K. & H. Lamp Co.; capital, \$12,000; to make and sell automobile lamps. Incorporators: Paul Krastin, John H. Hart.

FLOYD, VA.—American Brake Lever Co.; capital, \$15,000; to manufacture brakes of all kinds. Incorporators: V. M. Sowder, R. F. Tompkins, S. R. Brame, J. M. Peterman.

HIGHMOUNT, N. Y.—Stein Tire & Rubber Co.; capital, \$10,000; to make tire and rubber goods. Incorporators: Jay N. Emley, Clarence E. Mundy, John N. Scelsa.

JERSEY CITY, N. J.—Seventh Avenue Garage; capital, \$25,000; to operate a garage business. Incorporators: Chas. H. Weller, Harvey B. Hall, Leo J. Cain.

KENILWORTH, N. J.—Kenilworth Rubber Works; capital, \$60,000; to make automobile tires. Incorporators: Geo. B. Bradshaw, Lester F. Dittenhoefer, Edward W. Lawlor.

MARTINSVILLE, OHIO.—Clucker & Hixson Co.; capital, \$2,500; to make and sell accessories. Incorporators: C. E. Westervelt, C. L. Hixson, Melcena West Hixson, W. B. Jackson, F. A. Kehrer.

NEW YORK CITY.—Senora Motor Horn Co.; capital, \$50,000; to manufacture automobile supplies. Incorporators: Russell Goldman, A. Fosbay, H. Neuhardt.

NEWARK, N. J.—Gray Specialty Co.; capital, \$125,000; to make automobile supplies. Incorporators: Edward Gray, Edward Gray, Jr., Theo. P. N. Gray.

RACINE, WIS.—Kelly-Racine Rubber Co.; capital was increased from \$500,000 to \$1,000,000.

RICHMOND, VA.—Hutzler & Co.; capital, \$25,000; to handle automobile supplies. Incorporators: H. C. Beattie, Sr., Jonas Marcuse, Leroy Hutzler.

SAN FRANCISCO, CAL.—Halliwell Company; capital, \$50,000; to handle accessories.

VINITA, OKLA.—Vinita Automobile Co.; capital, \$10,000; to deal in motor cars. Incorporators: Walter A. Cronan, M. R. Kapp.

WILMINGTON, DEL.—Lake Shore Building Co.; capital, \$400,000; to operate garage.

# OF INTEREST *to the* INDUSTRY



**A**KRON, O.—The magnificent new plant of the Firestone Tire & Rubber Company illustrates the wonderful growth in the automobile and tire industry. Less than a dozen years ago the company occupied a small factory employing only a score of hands. The new plant, covering many acres of ground, includes the largest tire building in the world and employs thousands of hands.

SYRACUSE, N. Y.—F. V. Coville has been appointed buyer for the H. H. Franklin Manufacturing Company, succeeding W. G. Lindsey, who resigned.

BOSTON, MASS.—The Boston branch of the Lenox Automobile Company has been moved from 16 Pleasant street to Columbus avenue.

BALTIMORE, MD.—The Goodyear Tire and Rubber Company, of Baltimore, has been conducting an exhibition of the no-rim-cut and non-skid Goodyear tire at its headquarters, 533 North Howard street.

BOSTON, MASS.—The building at 1070 Boylston street is now being remodeled and when the work is completed the Metz company will move into it from their present salesrooms on Huntington avenue.

FLINT, MICH.—After having been connected with the W. A. Patterson Company for several years, Patrick H. Doherty has resigned to become associated with Benjamin Rozensweig, Jr., in the auto parts business.

SYRACUSE, N. Y.—Bert S. Bingham, district manager in New York and Pennsylvania for the Regal Motor Car Company, has just closed a 1912 Regal contract with the Syracuse Regal Auto Company, 1205 West Genesee street.

FLINT, MICH.—Floyd A. Allen, acting assistant to General Manager Nash of the Buick Motor Company, has been promoted to the position of assistant secretary and treasurer of the company, with headquarters at the local plant.

ATLANTA, GA.—The Velie Motor Vehicle Company, of Moline, has opened a branch house at No. 247-249 Peachtree street, Atlanta, Ga., for the purpose of distributing the line of automobiles and trucks throughout the southeastern part of the United States.

LANSING, MICH.—The Olds Motor Works is to open a branch in Saginaw for the distribution of automobiles in that city and surrounding territory. William H. Watt will be in charge of the branch. The property selected is just off Jefferson avenue in Saginaw.

BALTIMORE, MD.—The latest truck to enter this field is the Federal, which is being handled by the Oakland Sales Company, representatives for the Oakland car, 107 West Mount Royal avenue. The company is the distributor for the truck in Maryland, Virginia and the District of Columbia.

JEFFERSON, WIS.—The Kenzler-Waverly Motor Co. has started work on the first unit of its new plant here, which will be a factory building, 60 x 100 feet and two stories high. The concern is a consolidation of the Waverly Mfg. Co., of Milwaukee, and the Kenzler-Waverly Co., of Cambridge, Wis.

TOLEDO, O.—The Mather Spring Co., which manufactures automobile springs, is building a handsome factory structure near the Willys-Overland plant. It will be ready for occupancy within a few weeks. The new plant covers a ground space of 80 x 400 feet and is constructed entirely of steel and brick. The working department is on the ground floor. The company is headed by Gordon Mather.

PHILADELPHIA, PA.—The Hess-Bright Manufacturing Company, makers of ball bearings, announce that they have received word from the Deutsche Waffen-und Munitionsfabriken, for whom they are importers, that the DWF have just been awarded the "Grand Premio" at the In-

ternational Industrial and Trade Exhibition of Turin, this being the highest distinction.

AKRON, O.—The annual meeting of the stockholders of the Diamond Rubber Company was held October 18, when the regular 3 1-2 per cent. dividend was declared, and in addition an extra dividend of 2 1-2 per cent. Officers elected were: F. A. Hardy, president; A. H. Marks, vice-president and general manager; W. B. Miller, secretary; A. H. Noah, treasurer; Guy Norward, assistant treasurer.

NEW YORK CITY.—An increase of 60 per cent. in shipments of cars over the same month last year is shown in the September traffic report of the United States Motor Company. The outbound shipments filled 1,090 carloads of Maxwell, Stoddard-Dayton, Columbia, and Brush cars, and Sampson freight and delivery motors. Eighty-five railroads shared in carrying this record breaking tonnage to all corners of the world.

TOLEDO, O.—The Champion Spark Plug Co. this week purchased from the Irving B. Heiett Co. a 1 1-2-acre building site on the Lake Shore railway tracks at Upton and Avondale avenues. Work will be started immediately on a new and modern fire-proof plant of the Monitor type, the building to be 102 x 72 feet. Robert Stranahan is president of the company, which came to Toledo from Boston a year ago.

MILWAUKEE, WIS.—The Yale Mfg. & Sales Co., Manufacturers' Home building, Milwaukee, manufacturing motor car signals and accessories, has purchased the entire plant of the defunct Oostburg Foundry Co., of Oostburg, Wis., and will in the future concentrate its manufacturing activities at Oostburg, the sales and executive offices remaining in Milwaukee. The Oostburg plant is one of the most complete in the northwest and ideal for the purpose.



# PATENTS GONE TO ISSUE

**BLOW-TORCH**—Combination of two gas outlets from separate gas vessels.

4. The blow-torch referred to in this patent (Fig. 1) comprises a cylindrical body formed with a slot in its wall and provided with concentric air and gas passages which have a common orifice, the passages communicating through an opening. Between the opening and orifice an apertured wall is placed in the air passage and means are provided for dividing the air passage between the wall and the orifice into a plurality of concentric passages. Within the air passage there is a tubular member having an apertured flange bearing against the wall. On the body is mounted a rotary sleeve rigidly connected with the tubular member mentioned which extends through the slot in the wall of the body.

No. 1,006,034—to Jacob Weintz, Cleveland, Ohio. Granted October 17, 1911; filed July 9, 1910.

**ODOMETER**—Milemeter in which the indicator disc is regulated by a spring.

2. The odometer consists of a wheel or disc rotatable to give a desired indication; a spring tending to bring the disc to a zero position is fixed at one end to the disc, while the other end is adapted to make shifting engagement or anchorage with fixed teeth; means for retaining the disc in any position that it is brought to and a release device operable upon the retaining means in such a way that the disc is left to the action of the spring.

No. 1,005,845—to Joseph W. Jones, New York. Granted October 17, 1911; filed August 7, 1908.

**AIR-COMPRESSOR**—Apparatus for condensing and cooling atmospheric air.

5. The compressor described in this patent (Fig. 2) is a combination of a power cylinder provided at one end with a connecting member adapted to deliver a fluid

thereto, and an axially disposed pumping cylinder at the other end of the power cylinder. Pistons working in both cylinders are connected with one another, and means are provided for permitting the passage of fluid past the power-cylinder piston in the direction of the connecting member. The pumping cylinder is provided with inlet and outlet ports, and the power cylinder has an inlet on the opposite side of its piston from that occupied by the connector.

No. 1,005,940—to Charles Jerome Costello and Stephen Guion Skinner, Chicago, Ill. Granted October 17, 1911; filed January, 23, 1911.

**CRANKING DEVICE**—A system of engine starting by means of compressed air.

1. This patent relates to an engine starter as the one shown in Fig. 3, which is operatively connected with one end of the crankshaft. The rotary device communicates with an air-storage tank, containing compressed air, by means of a plurality of air passages, valves being used to control the flow of air in these passages, the valves being operated by a hand lever and mechanism adapted to close and open these valves. An air passage between the passages above mentioned leads to the connection between the rotary device and the engine shaft.

No. 1,006,063—to John S. Clarke, East Cleveland, Ohio. Granted October 17, 1911; filed July 1, 1910.

**DRIVE FOR AUTOMOBILES**—Transmission of power to wheels through two driveshafts.

The manner of driving two wheels (Fig. 4) is the subject of this patent, which covers the combination of a frame supported on these wheels with driveshafts, one being geared to each wheel, the shafts converging toward a point at a distance horizontally from the axis of the wheels mentioned. At the point of convergence a balance gear is mounted on the frame and it is adapted to rotate the shafts and per-

mit independent motion of the shafts, which, together with the gearing, are enclosed in casings secured to the driving wheels, converging toward each other and united at their adjacent ends.

No. 1,005,863—to William M. Miggett, Ann Arbor, Mich. Granted October 17, 1911; filed December 31, 1909.

**INTERNAL COMBUSTION ENGINE**—Engine of the rotary-valve type, the valve having a main and an auxiliary port.

5. The illustration (Fig. 5) is of an internal combustion motor with a working cylinder having main intake and exhaust ports, and a valve mechanism controlling these ports including a rotary valve, having a main port adapted to register with the exhaust port, and also an auxiliary port at an angle to the main port. Means are provided for rotating the valve from the crankshaft, and for shifting the valve to bring the auxiliary port into operation.

No. 1,006,095—to Russell Huff, Detroit, Mich. Granted October 17, 1911; filed May 11, 1911.

**RUNNING-GEAR**—System of chassis suspension.

1. The patent refers to a running-gear, front and rear axles, a reach connecting them which has rear hounds, the axle comprising substantially flat elongated bars having L-shaped ends, one secured above and one below on the rear end of the reach and the hound, stub axles having bodies arranged between the L-shaped ends, bolts penetrating the L-shaped ends and the bodies, the bolts being extended upwardly, thus affording means for holding a wagon body in place, wheels for the front axles and stub axles, and connections between the bodies of the stub axle and the front axle to cause them to oscillate in unison.

No. 1,005,909—to Fleming H. Weaver, Griffin, Ga. Granted October 17, 1911; filed April 29, 1911.

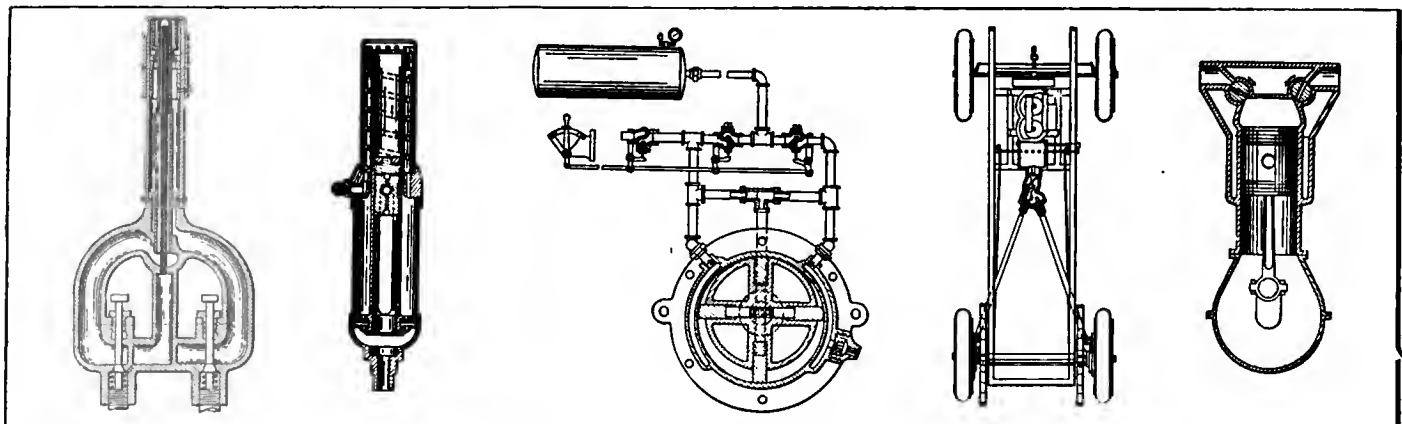

Fig. 1—Weintz blow-torch. Fig. 2—Costello-Skinner air compressor. Fig. 3—Clarke cranking device. Fig. 4—Miggett drive. Fig. 5—Huff engine

# Newest Ideas Among the Accessories

## Neverout Radiator Heater

**T**HE Neverout Radiator, Figs. 1 and 2, is made with the object of keeping the circulating water in the piping system of an automobile warm and in circulation, while the motor is not working, and the car, in a good many cases, standing in a cool place. The garage type of heater is seen in Fig. 1, where it is temporarily attached to the radiator, by hooking the

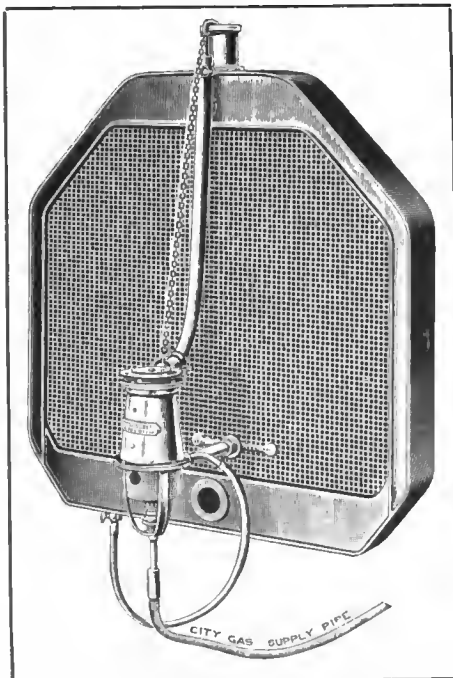

Fig. 1—Neverout radiator heater, garage type

apparatus on to the filler hole, after removing the radiator cap. The bracket of the device is made to bear against the face of the radiator, while one tube is used to connect the heater to the petcock of the radiator, and the other to permit of feeding city gas to the burner contained in the heater. After opening the petcock and lighting the burner, the water which flows to the heater, or boiler, as it might be called, is rapidly heated and raised to the height of the filler cap, thus keeping up the circulating of the water.

The original type of the Neverout heater is shown in Fig. 2, where it is permanently attached to the radiator. The burner of this type burns acetylene gas and is connected to the tank by means of a rubber tube. This type of heater is a double-walled cylinder of about 4 inches in length with cross-staggered copper tubes connecting the walls, around and between which the acetylene gas passes. The flame is produced on a burner resembling the Bunsen type, and the oxy-acetylene flame has a temperature

of about 3,000 degrees at the tip of the inner cone. The double-walled jacket has a connection passing from its upper end through the lateral air space of the radiator and communicating by a concealed 1-4-inch copper tube with the upper radiator portion. The lower portion of the jacket is connected to the lower radiator regions in a similar way. This device is effective in keeping up the circulation in the cooling system with the power shut off, and it is claimed that by turning the flame to its maximum size the water in the piping may be made to boil.

The device uses about four times as much oxygen as it does acetylene, and under normal conditions it burns only about half a cubic foot of gas per hour, so that it is very inexpensive. At all events, this means of keeping the water warm is less expensive to keep the engine running, perhaps for a half hour or longer, only to avoid freezing of the cooling water.

The Neverout heater is manufactured by the Rose Manufacturing Company, 917 Arch street, Philadelphia, Pa.

## Aviator Goggles

The aviator type of goggles is illustrated in Fig. 3. It is constructed with the idea to afford the eyes of the motorist a thorough and efficient ventilation. This is necessary, as otherwise vapor will accumulate on the inside of the goggle glass plates and obstruct the view of the automobilist as well as his well-being, so far as his eyes and their functioning are concerned. The body of the goggles is made of soft rubber, into which the oculars made of plate glass, are set. The tube surrounding the plates is made with air outlets directing a constant stream of cool air against the glass plates if air is permitted

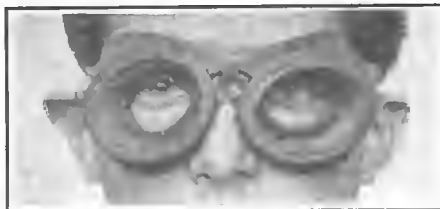

Fig. 3—The Aviator goggles ventilate the eyes

to enter the tubes. This takes place through the medium of the air inlet which is of funnel shape and placed upon the communicating portion of the goggles between the two ocular portions. When the motorcar is in motion, the air striking the funnel-shaped rubber mouth is caught in the same and led through the rubber tubing to the outlets whence it flows to the inside of the goggle space. After sweeping over

the glass plates the air passes out through vents opposite the ones through which it came in, and after passing through part of the rubber tubing, leaves it at the right and left sides of the respective eyes. By ventilating the inner goggle space, the eyes are enabled to continue in giving off their surplus of moisture. If this process is restrained, the comfort of the eyes as well as their working capacity is impaired.

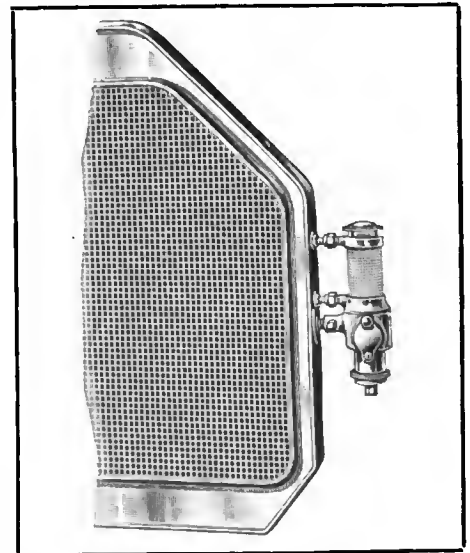

Fig. 2—Permanent type of Neverout radiator heater

The Aviator goggles, which are of a French make, are handled on this side by the W. C. P. Supply House, 1739 Broadway, New York City.

## Buckeye Electric Drill

The Buckeye type of drill is a portable breast drill of convenient shape, to which has been adapted an electric motor drive. The motor has been given particular attention to make it both efficient and light. It is wound for either alternating or direct current, as well as a combination winding which will enable it to be operated on the same voltage in either alternating or direct current. The latter winding, however, is not recommended, unless it be a necessity. The drill is reversible by manipulating the motor, so that when the drill breaks it is possible to prevent more serious damage by reversing the motor. Besides being used for drilling, this instrument is adapted to tapping. The spindle is brought into locking position by means of a special patented spindle lock. The weight of the entire outfit complete with cord and socket is 12 1-2 pounds. Capacity, zero to 3-8 inches. The drill is made by the American Foundry Company, Leipsic, Ohio.

# THE AUTOMOBILE

## Comfort in Winter Driving



Zero weather has no terrors en tour for the lady equipped like this

when it is not being used on a very cold day. The tabs look like a part of the crown except when they are in use, but when they are in action they pull down to the collar and fasten under the chin, thus making a very warm, compact bit of headgear.

The English golf cap is also exceedingly popular and differs from the double-snap cap in that it has no ear-tabs. The ears are protected by a strip of cloth that may be pulled down from a telescoped position outside the body of the cap. A variation of the golf cap is the English automobile cap. This is made on the same lines, but the part that pulls down over the ears when

**S**PECIAL clothing to make possible the full enjoyment of automobiling costs in the neighborhood of \$50 a year for each individual motorist. Outfits of a certain character can be had for less and they may cost almost any amount more, but the average expenditure is about the figure cited.

If there are 450,000 pleasure automobiles in operation in the United States, and if there are three persons associated with each car, the aggregate cost of clothing per annum for automobiling would reach the astonishing total of \$18,000,000.

In Winter, and in fact in both Spring and Autumn, comfortably warm clothing is almost as essential to automobiling as the car itself. Nothing could be more disagreeable than a long ride on a cold day where the lack of warm clothing makes itself apparent in chilled bodies and shivering nerves. On the other hand, a ride even over frozen roads and against a nipping wind is a magnificent pleasure if proper preparations for it have been made in the way of clothing.

Some of the characteristic lines of clothing that are being shown this season include the following: Caps, hoods, bonnets, polo-coats, fur coats, leather-lined fur coats, cloth coats, waterproofs, slip-overs, ponchos, gaberdines, spring pants, scarfs, gloves, muffs for hands and feet, boots, robes, puttees and leggings.

Taking these in the order given, the line of caps shown this season is limited to three types of cloth caps and two types of fur caps. Perhaps the most popular of these is what is known as the double-snap tourist. It is made in a variety of materials, silk-lined, and its distinguishing feature is in the ear-tabs which are fastened on top of the cap



The Shetland wool muffler often proves a real comforter

Knitted hoods like this add piquaney to beauty in the car

required is made either of cloth or fur. In cost the golf caps are about the same as the tourists.

For those who wish something different there are high band tourist caps and gentlemen's driving hats. The first of these is not new this season and the second is a peculiarly rakish appearing hat, with the back of the rim flattened against the crown and the peak extended and pulled down over the eyes. These hats sell for from \$2.50 to \$3.

In the line of fur caps there are two chief styles. The first is known as the Detroit and consists of a round crown, fitting snugly against the head. The rim is divided to form a peak that can be pulled down over the forehead and the rest of the rim can be turned down to form a warm comfortable protection for the neck and ears. These caps are made in all kinds of fur, and one variation may be noted in the fact that patent leather peaks may be had in place of the skin.

The other type of fur cap is the Alexis, a brimless, fedora shape such as is popular in Russia. The Alexis has an adjustable band that may be pulled down to ward off inclement weather. Persian lamb is the favorite material for this style. Fur caps may be had at any price between \$2.50 and \$30, the material ranging all the way from dog to sealskin.

When Miladi goes a-touring and the attack of Jack Frost is sharp and insistent there are many items in the grand total of automobile clothing that are in demand. Knitted hoods, varying all the way from the dainty little head covers something like those her Grandmamma used to manufacture while the dancing light from the open fire glistened from the moving needles, to

the ultra-modern aviation hood that is the final word in this line, have been prepared for her comfort. Both hoods and aviation caps are made in a wealth of color, ranging from demure gray with white lace and a ruffle over her eyes to the gaily fashioned and tufted contraption that she affects when taking a short biplane ride or its equivalent in the automobile. An improvement over last year is the silk lining to keep out the wind. She can pay from \$1.50 to \$5 for these styles and look bewitching in either.

In the line of bonnets the field is wide.

There is one confection now being displayed that will undoubtedly have a considerable vogue this season. This is a little flat, close-fitting bonnet classified as a poke. It is made of strengthened silk or taffeta and has its veil attached. The most striking example is the one shown in coronation purple. This color, by the way, is exceedingly popular and will be used extensively during the Winter. There are also poke bonnets made up in black that look just enough like widow's bonnets to be fascinating and yet carry some little dash of color to show that they are not sure-enough mourning. These cost from \$5 to \$15.

Fur caps in several styles will be used extensively, the Beauty being a leader. This is a round type of cap with peak and sides that turn up or down according to the desire of the wearer. They sell from \$8 to \$25, and are made of every conceivable kind of fur. The beaver skin makes a striking cap of this variety.

The most popular style of coat for men and women this season is made either of fur or cloth with combination collar. When the combination is off the best coat looks like any other full cut overcoat with rolling collar and revers, but when it is desired to use the combination the wearer may button the left lapel under the right side of the collar. Then by turning up an inch of the back of the collar and catching the opening together with a heavy hook and eye, the coat gives the impression of one of those trim, smooth military affairs. They come in all sorts of materials and in the polo-coat type range from \$18 to \$50 in price.

Furs costing from \$50 to \$1000, the latter being for very choice specimens of rich skins and the former representing a good



The Detroit style of fur cap is popular in cold weather

How the back turns down to keep off cold winds from the neck

general average price, will be seen very generally. These are made of wallaby, coon, calf, dog, Japanese cat, civet, leopard, marmot, muskrat, beaver and a dozen other varieties.

All the coats made of fur and most of those constructed of cloth and designed for use in exposed parts of the car are fitted with wrist windshields. These are in effect woolen wristlets fastened into each sleeve so that when the wearer slips into the coat his hands will pass through the wristlets, and no matter how sharply the wind may blow his arms will not become chilled.

Last year a line of coats was displayed with a permanent leather lining throughout. The leather was of flexible texture and proved to be advantageous in very cold weather. This year a slight modification of this style has been made. The leather lining is made entirely separate from the coat itself, and is designed so that it may be worn with any kind of outer garment. In effect it is a close-fitting garment of leather that may be slipped on in excessively cold weather and left off in moderate temperature.

Such leather garments as described can be had at \$35. They may be used with either cloth or fur overcoats.

In the line of waterproofs too much emphasis cannot be given. A waterproof garment of some kind is absolutely necessary to automobiling in variable weather, even if it is only a slicker or an oilskin. The slip-over type of raincoat has been popular for several years. This garment is made of pure rubber and is light and easily carried. As its name suggests, it slips over the head and laces up at the neck. It covers the whole body. It costs around \$5. The poncho type is newer. It is made of heavily rubberized cloth, and the neck is



Two views of the popular and serviceable type of cap for automobile wear. The protective flap can be pulled down in a moment

fitted with a yoke of pure rubber that fits snugly after it is drawn on over the head. The poncho type sells for \$7.50 to \$10. There are also rubberized coats that cost \$15 up and look almost like an ordinary overcoat, and there are lines of cravenettes of various styles and types that are familiar. In fact, all the overcoats made especially for automobilists are cravenetted to keep out wind and rain. The English gaberdine coat, with military collar made with a velvet band, is a trim-looking, comfortable garment.

One of the unique features of the sea-

son is a device called spring pants, just plain pants. In the final analysis they consist of five steel springs, made in circular shape but open at one side. The top spring is larger than the others and is designed to open and snap close around the waist. The two medium-sized springs perform the same service about the knees and the little ones grasp the ankles. Draped from the big spring to the little ones is a covering of waterproof cloth. When the driver adjusts the spring pants he snaps the waist spring around his body and the knee and ankle springs around his legs, covering himself with an impermeable layer of waterproof which will defy the elements. The spring pants are made not only in plain waterproof cloth, but also in all kinds of fur. In their simplest form they cost \$5 a pair, and they may run up to \$100, depending on the kind of fur desired.

Even the little details of comfort are provided for to-day and one finds a complete line of soft, woolen scarfs for the neck. These cost from \$2 to \$4.50, and the best examples shown are made of Shetland wool imported for the purpose.

It has been said that if the hands and feet are warm, the whole body will be comfortable, and so the provision for gloves and boots in going on a trip in cold weather is among the most important.

Gloves for use in the car ought to be warm and the prevailing styles offered to the public are fleece-lined or fur-lined. For the driver they are gauntleted and lined, and for the lady passenger they are daintily shaped as a dress glove. They are made of every kind of glove fabric and leather, and cost from \$250 to \$25 a pair. There is no difference between the prevailing styles of automobile gloves and those



Miladi looks charming either in silk bonnet or woolen hood, particularly if she is protected by ample wet weather garb such as these





The slip-on cover is a Godsend in the rain

that have been perfectly familiar to the outdoor winter public for years, except that the automobile gloves are warmer and more flexible.

Ordinary shoes are generally used in the car both Summer and Winter, and much discomfort is experienced thereby. Of course they will still do if proper precautions have been made to protect the feet with robes or muffs or something of that sort. But if one wants solid comfort in the coldest weather, fleece-lined boots will prove a revelation. These are made of pliable leather and are either 6, 8 or 10 inches high, opening on the side and fastening with straps. These answer the question perfectly and cost from \$8 to \$13.50 a pair. They are also made in hip sizes for \$25.

One might ask why a lady possessing a fine muff should need special equipment of that sort for automobiling. The answer is: bad weather. A Russian sable muff probably would keep her hands warm, but she would have to be a stoic indeed if she could enjoy a trip through the rain in which the valuable muff was deluged with water. To fill this gap the purveyors to automobile comfort have prepared a leather-covered, fleece and down-lined muff that will defy the elements that sells for \$8 and \$10. In the line of foot protection there is the foot muff, made to lie on the floor of the car and large enough to contain a pair of feet. They are made of dog or coon skin and are said to be quite durable and very comfortable. They cost from \$5 to \$8.50.

Robes are not strictly clothing, but nevertheless they are important on an automobile trip. Fur robes of very high price are not so popular as they have been in the past. It has been found that the percentage of loss by thievery in the matter of fur robes is unduly large, and therefore the automobile owners are hesitating about equipping their cars with such expensive portable stuff. In the place of the magnificent fur robes that are still to be seen in appreciable number

the automobilists are turning to the cloth robe interlined with pure rubber. These only cost from \$10 to \$17.50 and serve every purpose of the more costly robes. They are slashed to allow the hands to be pushed inside, and some of them are made to serve as foot muffs as well as protection for the legs and lap.

Puttees and leggings are not quite so lively this year as they have been in the past. The yellow leather puttee has practically passed away as a factor in the automobile clothing field, and in its place has come the black leather puttee. These are made either of domestic leather or English pigskin and cost from \$5 to \$10 a pair. The proper caper nowadays seems to be for the automobilist to wear golf stockings and low shoes.

An extensive line of veilings is shown for the ladies. The leader of the line is a washable, dust-proof fabric of exceeding lightness. The veils come in all sorts of colors and fabrics.

Another important garment for automobiling in cold weather is the sweater. Specially woven garments of this description sell for \$8.50 up. Mica hoods are still considered good by those who know. These hoods are made of crêpe de chine or China silk and cover the whole head and shoulders. A plate of mica is inserted in an opening in the fabric so as to allow the wearer to see.

Regular suits, cravenetted for automobiling, but in other respects like ordinary clothing, cost from \$17.50 to \$50.

No special underwear and stockings are needed in automobiling if proper outer garments are prepared.

The man who essays to drive in his business suit, costing, say, \$60, will probably pay more for his automobile clothing in the

course of a year than the man who has special clothing for the purpose. Just a little lubricating oil will put a good suit of clothes out of commission, and a brake lever has been known to destroy a \$40 coat in the twinkling of an eye. Hinges on the doors of the car are frequently destructive of good clothing.

The man who spends \$50 a year to be comfortable in his car through the medium of automobile clothing will probably have more money at the end of five years than the owner who economizes in this



The driver in wide cut gaberdine for moderate weather



Leather linings suitable for any kind of overcoat



Cold will have only a good effect upon the driver so equipped

respect and spoils his regular clothes. It is absolutely certain that he will have more comfort during the five years.

A typical man's outfit for automobiling might include the following items: Cap, \$2.50; coat, \$50; slip-on, \$6; gloves, \$7.50; suit of clothes, \$40; boots, \$8. Total, \$114. By making renewals when needed the average cost per year for this outfit need not exceed \$50.

But he will have to dig a little deeper in outfitting Miladi. Something as follows: Bonnet, \$15; cap, \$3.50; hat, \$7.50; coat, \$50; raincoat, \$12; gloves, \$6; muff, \$8; foot-muff, \$5. Total, \$107.

Of course he may wish to do the thing economically, and then it is possible to cut down several of the items so as to bring the initial cost to about \$85.

On the other hand, if comfort is the object and money is not, the outfit may run up to \$1000 or more with great facility. To illustrate this phase of the situation it may be related that several outfits purchased this Fall in New York have totaled \$2000 each and did not seem to be particularly elaborate at that. On the other hand, a very simple, comfortable outfit is within the financial limits of every man who owns an automobile.

Parsimony as far as special clothing is concerned means waste as applied to ordinary clothing and certainly spells discomfort and dissatisfaction. Reasonable expenditure, on the other hand, means economy on general lines, and the pleasure that will be the result will add greatly to the enjoyment of the automobile all the year around.

While the weather so far this Fall has not been particularly severe, the advantages of wearing adequate clothing while touring was never better exemplified than during the recent Glidden Tour. Out of the 273 persons who started from New York on the long grind to Florida there was not one who had not made some special provision in the way of clothing.

There were new and natty outfits containing the latest ideas in clothing and there were makeshifts of every sort and description. There were also combinations of the latest things with old, and from every



This driver would do well to put on a sou'wester



Rubber coat laced at neck and protected at wrists



The new overcoats are astonishingly comfortable



Ready for a ride in any kind of weather

viewpoint the clothing equipment of the passengers on the tour was interesting.

In large measure the professional element was well equipped. The factory drivers and crews, first of all, had adequate waterproofs. These included sou'westers of rubber, slip-ons of heavy rubber and flexible boots. The sleeves of the rubber shirts were protected with wind and weather shields and their gloves were not only waterproof, but so arranged at the sleeves that the pelting rain had no chance to find entrance to their skin.

It was found that goggles were useless in the heavy rain storms met with in Virginia and Florida and chances had to be taken in following other cars. Quite a lot of mud and gravel was flung in the faces of the tourists while speeding in the rain and there seems to be no way to obviate this difficulty except the perfectly obvious one of not driving in weather that is so bad as to eliminate all kinds of pleasure and satisfaction in traveling.

In the amateur section of the tour there was a wide difference in equipment to be observed. A number of the gentlemen drivers wore ordinary business clothing throughout. It is safe to say that all such ruined at least one suit of clothes. One Florida owner who took part said at Jacksonville that he had spoiled three suits, one of which was rendered shapeless after reaching Roanoke, another was covered with grease and oil when it became necessary for him to tighten several bolts in the base of his engine, and the third succumbed to the drenching rain within the limits of his home city. He had a heavy rubber coat, but no boots, and, as a result, he had wet feet for 3 days and caught a severe cold.

On the other hand, there were eight contestants in the amateur section of the tour who bought complete outfits of special clothing before leaving New York. These experienced a fine trip, despite its drawbacks. They had caps for dry weather, furs for cold weather, slickers and sou'west-

ers for wet weather, boots and also provided themselves with several pairs of gloves.

The tour demonstrated the need of a supply of gloves about as well as it did any one single item. It proved that heavy buckskin gloves worn in wet weather would be of no use for a week afterward, if at all, and that the ordinary type of walking glove would last about two hours if its owner attempted to handle the wheel of a heavy car in slippery going after it had been rained upon. Good gloves of the thoroughly waterproof type were demonstrated to be of the highest importance to the man who wants to drive in the rain.

As has been intimated, the lack of some one essential part of the clothing equipment will bring about an extraordinary amount of discomfort. Take the case of the man who forgot to buy waterproof foot covering and leg covering and remembered everything else. He was quite as miserable after facing a driving rain for 1 hour as was the fellow whose rain-hood leaked at the neck. It was found that water running down one's back was not a whit more uncomfortable than water running into one's shoes.

The ladies of the party, numbering twenty-seven all told, were protected in a large measure by the tops of their cars, but there were several who rode the entire distance without such protection and they showed an astonishing amount of care in selecting their outfits. Miss Marks, who drove the Columbia all the way to Jacksonville, had an equipment that was peculiarly suitable for the occasion. For dry weather she wore a leather bound cap of jaunty effect and in wet weather she donned a sou'wester that reached clear to her shoulders all around. She had two raincoats, one a light slip-on and the other a heavy slicker, and for dry weather she wore one of the new polo coats that are so much in vogue. She had boots that would defy any rain, reaching nearly to



Gloves and boots seem much more important if you are not well supplied with them and happen to be caught in rainy or cold weather

her knees, and ordinary stout shoes for ordinary driving. Her rain gloves fitted inside the sleeves of her slicker and rested against the windshield.

It is notable and a fact that her Columbia car made every control within the time limit and that she seemed to enjoy every foot of the journey.

There were several of the ladies who made no special preparation for the tour except for raincoats and veils. They had a trying trip from every viewpoint. For sheer gameness the exhibition of these ladies was remarkable. Arriving at Roanoke after a wild ride through the Blue Ridge and across numerous fords that looked like swirling rivers, they were mostly wet to the skin when their cars

drew up in front of the hotel. They were stiff from holding cramped positions to avoid the rain and cold and miserable as possible. But within an hour each appeared in the lobby attired in evening costume, apparently none the worse for the wreck of clothes and the discomfort of the rainy ride.

The evening costumes were less in evidence the next night, and by the time the party reached Atlanta there was not a presentable evening dress in the whole tour.

If these ladies had taken the pains to secure touring equipment that would serve in all kinds of weather and had paid less attention to the dress of the ball-room, they would have enjoyed the trip much more. Only a certain amount of luggage can be carried in an automobile in any event, and experience proves that it should first be devoted to carrying the prime essentials to comfort. Then if there is any spare space and carrying capacity in the car it may be used for the decorative effects in dress.

Of course the Glidden Tour does not fairly represent automobile touring conditions. It was one of those things that go to prove that it is the exceptional events that have to be provided for. And in nothing does it better emphasize this particular angle than in the matter of clothing.

It would be comparatively simple to overdo the special clothing equipment for automobiling and the use of considerable judgment is required in selecting just what is needed. Too much clothing is not as bad as too little, but it presents certain inconveniences that it would be well to eliminate. Besides costing much unnecessary money,



The woolen cap that pulls down over ears and neck and is equipped with a peak is absolute necessary unless one has furs



Fleece-lined boots, strapping snugly around the leg and gauntletted mittens so constructed as to allow the fingers play are two things that deserve attention

each additional pound carried in the car causes extra wear on tires and mechanism, and as clothing is light and bulky a few unnecessary pounds make their presence distinctly felt on a long trip:

An unopened suit case on a long automobile trip is an economic outrage in which the owner of the car, driver and passengers are all aggrieved parties and in which its owner can take no pride or satisfaction.

Therefore, as unneeded garments are a disadvantage, care should be used before the start to select only such clothing and accessories as stand a good chance of being used.

The photographs from which the illustrations for this article were made were taken by THE AUTOMOBILE staff photographer from stock loaned for the purpose by The Automobile Supply Company.

fact that the account contained an item of \$1395.64 for repairing the roads in Fairmount Park, an expense that heretofore has been assumed by the municipality, but which this year devolved upon the Quaker City Motor Club to pay out of the money to be donated to charity.

The Q. C. M. C. came out of the race on the wrong side of the ledger. The actual expenses of the contest amounted to \$9422.37. The club's receipts from entrance fees only footed up to \$8500, leaving a deficit of \$922.37.

### Around Georgia Tour

ATLANTA, GA., Oct. 30—Owing to the complaints of Southern amateur owners who took part in the recent Glidden tour the promoters of the Tour Around Georgia, which will be run to the Savannah races, have announced most extremely liberal running conditions for their event. The top speed required will be but 18 miles an hour. It is also provided that the contestants will be allowed to run right along without using the hour allowed for the noon control. They will also be allowed to make repairs on their cars on their town time.

### T. C. A. Tour's Progress

CHEWAW, S. C., Oct. 30—The Atlanta-to-Richmond tour which is being conducted under the auspices of the Capitol Highway Association, the American Association for Highway Improvement, and the Chamber of Commerce of Richmond, Va., under the direction of the Touring Club of America, stopped here for luncheon. The tour left Camden this morning and will stop to-night at Pinehurst, N. C. The party expects to reach Richmond on Friday night. A Chalmers Six driven by Freeman Monroe, of Detroit, Mich., is leading the party under the command of Col. Henry MacNair, editor of the Official T. C. A. Automobile Blue Book.

## Quakers Lost Money on Fairmount

PHILADELPHIA, Oct. 30—Fred C. Dunlap, chairman of the Contest Committee of the Quaker City Motor Club, to-day submitted to Mayor Reyburn a report of the receipts and expenditures of the Fairmount Park 200-mile road race held on Monday, October 9. The statement shows that a smaller sum than usual will be turned over to the beneficiaries—in this instance the Police Pension Fund and the Fairmount Park Guard Pension Fund.

The total sum realized above expenses amounts to \$3036.57, of which the first-named fund will receive \$1518.29 and the Park Guards \$1518.28, the money being equally divided. Originally it was the intention to include a third charity, the Children's Playground Committee to share in the general distribution of the profits, but that organization was eliminated by reason of the disappointingly small amount left after all expenses had been paid.

In detail the statement shows receipts, which embraced the sums realized from the sale of grandstand seats and parking spaces, of \$8527, from which expenditures amount-

ing to \$5490.43 were deducted, leaving a profit of \$3037.57 for the charity fund. The expenses incurred were larger than they ordinarily would have been by reason of the



Masks to protect the face from very cold winds and made of leather or other material with mica window, and one of the 1912 models of Arctic overcoats





Crossing the Suwannee river, famous in song

The reception which was accorded the tourists as they swung into Atlanta was a most enthusiastic one

An elegant road through the turpentine country

## Fourteen Clean Scores in Glidden

**T**HE Maxwell factory team, entered as representing Tarrytown, N. Y., won the Glidden Trophy of 1911, scoring perfect for all three cars during the entire 11 days of running from New York to Jacksonville. Two of the cars would have been penalized for the run into Roanoke, Va., but for the ruling of Referee Walker that all cars should be allowed 26 minutes on account of delays resulting from a blockade of the road by two automobile fire engines that mired down a few miles south of Natural Bridge and held up the Glidden cars for that length of time. Despite this delay one of the cars checked in on time and the others were only 6 minutes late.

The winning was accomplished with much certainty and the cars were scientifically handled throughout. Deadly speed when unnecessary to make controls was not resorted to. There was no effort to check the team in with an hour to spare, simply to get in ahead of others. The three drivers, Walls, Gager and Costello, are experts and drove on a definite speed schedule just

sufficient to make controls with an allowance for possible tire trouble and for adjustments before checking in.

The Stevens-Duryea team, representing Atlanta, was a close second in the race for the trophy. These big cars, numbers 11, 39 and 66, received a total of nineteen demerits, all of which were scored against number 66, entered by Brooks Morgan and driven by Murphy. The car was 36 minutes late in reaching Roanoke, owing to the blockade and was allowed 26 minutes under the rule, leaving it with ten points for the day. The following day it was 9 minutes late in reaching Winston-Salem. The other cars were clean throughout the running.

The same sort of a story may be told of the Jacksonville Cadillac team, which had two clean scores at the finish and one car, Number 47, penalized 23 minutes for lateness into Roanoke.

Similarly reads the story of the Ford team's showing. Car 43 suffered a broken axle out of Roanoke and was demerited 125 points. The others were clean all the way.



Group of officials taken at Thomas. Secretary Butler on lower step



The wrecked car in which Secretary Butler lost his life



FULL STORY OF THE GLIDDEN TOUR TOLD IN THE PENALIZATION TABLES

Team	1	2	3	4	5	6	7	8	9	10	11	Penal-ization.	Team	1	2	3	4	5	6	7	8	9	10	11	Penal-ization.
<b>TARAVTOWN</b>													<b>EVERGLADES.</b>												
1 Maxwell	..	..	..	..	..	..	..	..	..	..	..	0	33 Cole	..	..	..	87	13	62	..	19	..	..	..	181
2 Maxwell	..	..	..	..	..	..	..	..	..	..	..	0	46 White	..	..	..	4	42	..	..	..	..	..	..	1050 1231
3 Maxwell	..	..	..	..	..	..	..	..	..	..	..	0	48 Cadillac	..	..	..	..	..	..	..	..	..	..	..	0
<b>ATLANTA No. 2.</b>													<b>CORDELE.</b>												
11 Stevens	..	..	..	..	..	..	..	..	..	..	..	0	60 Oldsmobile	..	..	..	4	81	26	39	1000	..	..	..	1150
39 Stevens	..	..	..	..	..	..	..	..	..	..	..	0	65 Oldsmobile	..	..	..	..	..	..	..	..	..	..	..	17 1175
66 Stevens	..	..	..	10	9	..	..	..	..	..	..	19	69 Oldsmobile	..	..	..	1	..	..	..	..	..	..	..	8
<b>JACKSONVILLE</b>													<b>ALBANY, GA.</b>												
32 Cadillac	..	..	..	..	..	..	..	..	..	..	..	0	34 Halladay	..	..	63	..	..	..	..	..	..	..	..	63
40 Cadillac	..	..	..	..	..	..	..	..	..	..	..	0	35 Halladay	..	..	..	..	228	..	..	..	..	..	..	228 1322
47 Cadillac	..	..	..	23	..	..	..	..	..	..	..	23	36 Halladay	..	..	..	..	..	..	..	..	..	..	..	1031
<b>ATLANTA, No. 3.</b>													<b>ATLANTA, No. 1.</b>												
43 Ford	..	..	..	125	..	..	..	..	..	..	..	125	8 Flanders	..	..	..	..	..	296	..	..	..	..	..	296
44 Ford	..	..	..	..	..	..	..	..	..	..	..	0	63 Flanders	..	..	..	..	104	..	..	..	..	..	..	1104 1405
45 Ford	..	..	..	..	..	..	..	..	..	..	..	0	61 Flanders	..	..	..	5	..	..	..	..	..	..	..	5
<b>LIVE OAK</b>													<b>WALTHAM, MASS.</b>												
31 Cadillac	..	..	..	..	189	..	..	..	..	..	..	189	15 Metz	..	..	..	..	130	24	6	..	..	..	..	Not in
51 Cadillac	..	..	..	13	..	..	..	..	..	..	..	74	16 Metz	..	..	..	..	57	..	328	..	..	..	..	Not in
74 Cadillac	..	..	3	..	..	..	..	..	..	..	..	3	17 Metz	..	..	..	..	1000	..	..	..	..	..	..	1000
<b>NASHVILLE.</b>													<b>ATLANTA, No. 6.</b>												
58 Marathon	..	..	..	72	153	..	..	..	..	..	..	225	18 Garford	..	..	..	960	10	..	..	..	..	..	..	97 0
57 Marathon	..	..	..	..	210	..	..	..	..	..	..	31	19 Mitchell	..	..	..	..	..	..	..	..	..	..	..	0 1970
56 Marathon	..	..	..	9	34	..	..	..	..	..	..	43	20 Schacht	..	..	..	..	1000	..	..	..	..	..	..	1000
<b>DETROIT.</b>													<b>ATLANTA, No. 7.</b>												
53 Flanders	..	..	..	591	..	..	..	21	..	..	..	612	21 Corbin	..	..	..	..	..	23	..	..	..	..	..	23
54 Flanders	..	..	..	..	..	..	..	..	..	..	..	0	14 White	..	..	..	152	981	1000	..	..	..	..	..	2133 3156
55 Flanders	..	..	..	416	..	..	..	..	..	..	..	416	22 Thomas	..	..	..	..	..	..	..	..	..	..	..	1000 1000
<b>Scores of Teams Disqualified by Withdrawals</b>													<b>FLORIDA.</b>												
<b>GEORGIA-DIXIE.</b>													28 Cadillac .. 4 .. .. .. .. 4												
4 Maxwell .. .. .. .. 0													29 Cadillac .. .. 226 .. .. .. Dis. .. 226 1344												
49 Columbia .. .. .. .. 0 1000													37 Cadillac .. .. 3 11 .. .. .. 14												
50 Maxwell .. .. 1000 .. .. .. 1000													<b>How the Individual Entrants Fared</b>												
<b>ATLANTA JOURNAL.</b>													27 Chalmers .. .. .. .. 13												
5 American .. .. .. .. 7 7													42 E.-M.-F. .. .. .. .. (withdrawn) 2342												
6 Thomas .. .. .. 1000 .. .. .. 1000 1034													26 Mitchell .. .. .. .. 88												
7 White .. .. .. 18 .. 9 .. .. 27													41 Winton .. .. .. .. 54												
<b>ATLANTA, No. 4.</b>													52 Packard .. .. .. .. 14												
10 Pierce .. .. .. 12 14 .. .. .. 14 40													59 Cadillac .. .. .. .. 146												
12 Marmon .. .. .. 1000 .. .. .. 1000 2148													70 Krit .. .. .. .. 45												
64 Pierce .. .. .. 3 105 .. .. 1000 .. 1108													71 Case .. .. .. .. 662												
													72 Haynes .. .. .. .. (withdrawn) 1728												
													73 Mitchell .. .. .. .. 18												

The Live Oak Cadillac team was heavily handicapped by the demerits imposed on Capt. W. J. Hillman's car. He waited for supper at Martinsville and was late in reaching Winston-Salem. The car also suffered clutch trouble at that stage of the tour. Both of the other members received penalties, No. 74 on the run into Gettysburg and No. 51 on the final day.

The Nashville Marathon team was roundly penalized on the fourth and fifth day's running and No. 57 broke spring and axle going into Jacksonville. This team, however, was the only one on the tour to make the whole distance under the power of its own engines. This happened because the three cars were the only ones that forded Back Creek without assistance. All the



Counting the contesting cars and the large escort, more than one hundred automobiles were in the line that started from Commerce



Not a little tire trouble was experienced by the contestants along that portion of the road which followed the foot of King's Mountain

others had one or more cars swamped in the raging torrent.

The Flanders factory team made a commendable showing most of the trip and one car came through with a clean score. Broken axles caused the others to be penalized.

The Metz team which had a clean score into Roanoke was overwhelmed by the run into Winston-Salem in the dark. The exceedingly rough mountain roads and the deep fords proved too much for No. 17, which broke a wheel and retired.

There were fourteen cars with clean scores at the end of the tour, namely: Maxwells 1, 2, 3 and 4, Stevens-Duryeas, 11 and 39, Cadillacs 32, 40 and 48, Fords 44 and 45, Flanders 54, Columbia 49 and Mitchell 19.

These cars drew for the Anderson, S. C., trophy, a huge silver punch bowl, and the choice fell upon Maxwell 4, the entry of Governor Hoke Smith, of Georgia.

The divisional prizes offered in each of the seven sections of Class A, consisting of \$200 in each class, were won by the following. Where more than one car is named the prize was divided: Division 1, Fords 44 and 45 and Flanders 54. Division 2, Mitchell 26. Division 3, Maxwells 1, 2, 3 and 4. Division 4, Cadillacs 32, 40 and 48. Division 5, Mitchell 19. Division 6, Stevens-Duryeas 11 and 39 and Columbia 49. Division 7, American 5.

The official cars all had a rough trip. The pacemaking Cunningham was wrecked at Tifton; the Pierce-Arrow press car was smashed early in the run in Virginia; the Reo pilots experienced

several accidents, one breaking a wheel and the other dislocating its propeller shaft in a North Carolina ford. The Reo truck made controls in good style and the Velie Press car was always on hand. The Chalmers Six had no trouble after the first day when it suffered a burned bearing.

### Rain Again the Last Day

JACKSONVILLE, FLA., Oct. 26—In a tropical downpour the Glidden Tour of 1911 finished its schedule here to-day after a wonderfully fast run across the dreaded sands of Florida. The start this morning from Live Oak was made at 8 o'clock and throughout the contesting column the impression was widely held that there would be no 20-mile cars to make clean scores for the day and that the chances were slim that any automobiles traveling on slower schedules than that would get through on time.

But the rain that worked such havoc in Virginia saved the day and the intermittent showers that fell in the morning aided the traction and were solely accountable for the fine showing made across the all but trackless waste.

Nearing Jacksonville the rain increased in intensity and when the cars were lined up for the run into the city the rain came down solidly. It spoiled the plans for a monster reception, which fact was not without its agreeable features to the tourists in view of the trial afforded by the Atlanta reception.



Chalmers press car in the pine forests near Live Oak



Several cars were delayed by a train across the road at Spartansburg



Pilots ask directions of convict road makers below Anderson, S. C.

The road from Live Oak was fair for a few miles and degenerated into a trail through pine barrens, winding along tortuously past swamps until Lake City was reached. The worst of the road lay between Lake City and Glen St. Mary, where the highway was meagerly marked and the sand would have been impassable at schedule time but for the hardening influence of the rain.

From Glen St. Mary to Jacksonville the road followed was a temporary trail largely built for the occasion. The building consisted in covering the softest spots with pine needles and marking the rest with confetti. The road is considered the worst in the country at its worst.

But when within 7 miles of the terminus the tourists came upon a magnificent macadam highway that will be eventually extended clear across the State.

Only two of the sixteen clean score cars that left Live Oak suffered penalties on the last day. These were American 5, which heated up in negotiating the sands, and Mitchell 73, which experienced tire trouble several times during the latter part of the run.

Otherwise the final standing of the teams and individuals was not disturbed.

### The Tour Summed Up

Dripping with rain, beaten by road and weather conditions almost from the start of the run from New York, the Glidden tour rolled into Jacksonville last Thursday. With spirits drooping under the tragic happening at Tifton, there was little lightness and happiness in the column that made



Waiting for road repairers to fix up a small culvert near Anderson, S. C.

the long trip, covering 1,454 miles in 11 days. Sixty-four typically representative American automobiles started from New York in the contesting division and only forty-seven finished with scores good enough to receive official cognizance.

On the face of the event this was a surprising showing, but under the surface there is an excellent reason. The wonder is not that seventeen cars fell out and were penalized at least 1,000 points each, but that forty-seven finished and fourteen had clean scores.

There were three running days when road conditions could not have been worse. The run into Gettysburg was hard, but the roads encountered in Pennsylvania were fine highways in comparison with the route on both sides of Roanoke and through the sands of Florida.

As fortune would have it rain fell in a deluge upon the tour after leaving Natural Bridge, making the road tractionless where it was not bottomless. This rain extended southward and converted what were supposed to be passable roads leading well up toward the summit of the Blue Ridge into smeary imitations of toboggan slides. Six unbridged creeks, swollen and angry by the rain in the hills, added to the problem of the run into Winston-Salem. In Florida the rain was a life-saver, hardening the sands so that it was possible for the cars to get through.

The major portion of the demerits imposed came on the fourth day or later, because of it. Many of the drivers were Southerners and most of them owned their own cars. The problem presented to them by the roads in Virginia was so complex that many of them took penalties rather than try to get in on time.



When the report of Secretary Butler's death was circulated, the tourists lined up near the scene of the accident to await instructions



Line-up of the twenty-six contestants in the Long Island Automobile Club's Schimpf trophy run

## Long Islanders' Secret Time Run

BROOKLYN, N. Y., Oct. 30—The contest for the Schimpf trophy, in which twenty-six members of the L. I. A. C. participated, started here on Saturday at 1 p. m. The contest was not one of skill, but one of luck rather. Before the start every contestant entered his name on a sealed envelope containing a total running time for the trip to Jamaica and return to the clubhouse. The only condition of the run was that on their way to Jamaica the tourists had to pass through Roslyn, East Norwich, Hicksville and Hempstead in the order named. Among the automobiles which took part in the pleasure run were several 1912 models.

During a dinner following the return of the "joy riders" to the club the envelopes were opened and the times demanded compared with the actual running times of the contestants. This process developed the result that Louis A. Vogel, Jr., was declared winner of the Schimpf trophy, approaching his secret time as near as 1 minute and 7 seconds. J. E. Frink, who came within 1 minute 8 seconds of the sealed time, was second, and W. H. Kouwenhoven third, with a difference of 2 minutes and 5 seconds. Several contestants experienced slight trouble with motor policemen, and it was due to the efforts of the donator of the trophy that the lawbreakers were given their liberty without considerable delay.

## Forty-four in Watson Cup Contest

SYRACUSE, N. Y., Oct. 30—Ernest O. Cowan, with a Firestone-Columbus, won the second annual Watson cup run, held Wednesday. The event was under the auspices of The Automobile Club of Syracuse, and had to be postponed several times because of bad weather. It was finally held under ideal weather conditions over a beautiful scenic route approximating 100 miles, dinner being had at Cortland.

The start and finish were from the court house in this city. Forty-four cars participated and there was not a single accident, barring a few punctures. Every car finished.

Mr. Cowan's time was 4:59:15 and the secret time established was 4:56:37. S. L. Devendorf made the run in exactly 4:59, but was debarred from holding the cup for the ensuing year because he was not a member of the club. A Ford accessory truck accompanied the "parade."

Mrs. Jane M. Bartels received the cup given the woman driver coming closest to the secret time. All those participating were unanimous in pronouncing the run a complete success and it will be repeated next year.

The officials were: Starter, C. A. Benjamin; referee, H. W. Smith; pilot, B. E. Watson; manager of run, Edward Churchill. Secretary Forman Wilkinson, George E. Messer and J. E. Doane figured the time.

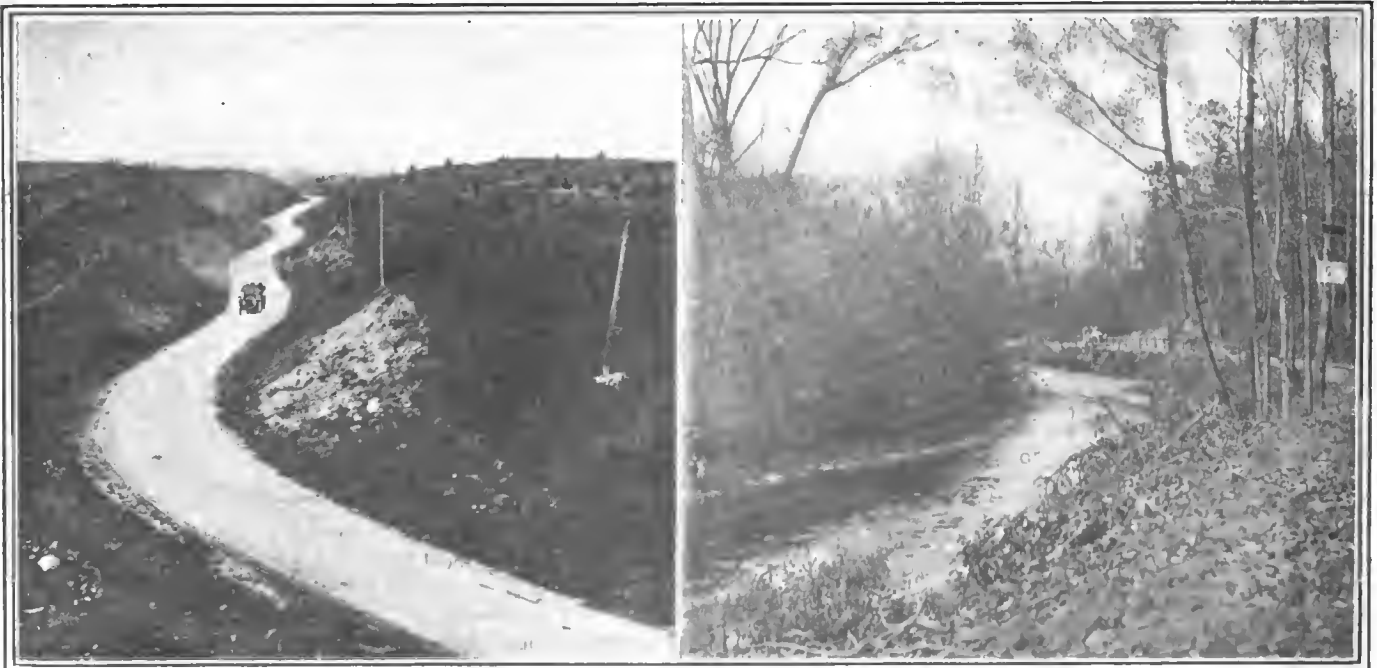

Some of the beauty spots encountered by the contestants in the Watson cup contest of the Automobile Club of Syracuse



## Berlin's International Show

**A**FTER an interval of four years since the last show was held in 1907 the German automobile industry has this year again arranged a large international automobile exhibition under the auspices of the Imperial Automobile Club and the Association of Automobile Manufacturers. It was opened October 12 by Prince Henry of Prussia after a preliminary introduction of the exhibits on the previous day to the journalists of Germany and the special representatives of foreign publications.

The exposition is located in large and sumptuous quarters close to the famous Zoological Garden of Berlin and the artistic arrangements and decorations as well as the superb lighting of the approaches to the building are universally praised, especially

hibition halls, could be intended only for arctic expeditions, as its unprotected propeller would be objectionable on any highway within the limits of civilization.

At a meeting of the Associated German Automobile Clubs on October 18, in connection with the exhibition and with the Duke of Ratibor in the chair, it was decided that there shall be no Prince Henry Cup race next year, a-twelvemonth being required for formulating a set of rules and regulations for this important event, when it is resumed for 1913, which shall be found to answer the technical and sporting requirements of the day and hour. Provisions were made for the organization of a race in the Spring for small vehicles not exceeding 8-horsepower, and the Northern German Automobile Club was authorized to



View of the International Exhibition at Berlin, held under the auspices of the Imperial Automobile Club and Manufacturers

in comparison with the earlier German exhibitions where a super-esthetic rococo style seemed to class with the mechanical nature of the exhibits. The decoration scheme for the stands has this year been made uniform for all, so far as signs, festoonings and flower pots are concerned.

Among the exhibits a motor sleigh driven by an aeroplane propeller at the rear and steered by means of small skids in front is particularly noticed for its oddity, while a small electric three-wheeler, driving by the single wheel in front, also attracts much attention from the large majority of the visitors who do not pretend to be able to judge the mechanical refinements which form the only new features at most of the stands of the large German and foreign exhibitors. The motor sleigh, which may be noticed in the accompanying general view of one of the ex-

hibit in conjunction with a number of other clubs for a large touring expedition, without speed trials, to take place in June, the rules to be approved first by the Imperial Club.

### American Wins Long Run

SAN FRANCISCO, CAL., Oct. 21.—The most severe automobile endurance run ever held in California came to a close Wednesday night when seven cars checked in at San Francisco after a run from here to Los Angeles and return, a distance of more than 1,000 miles. The penalties of each car were as follows: American "50," 87; Warren "30," 487; Flanders runabout, 857; American "50," 977; S. G. V., 1,195; Cartercar, 2,030; Flanders touring, 2,048.





Banking the turn from the grand stand stretch into Waters Road



Oiling a straightaway in preparation for Savannah road races

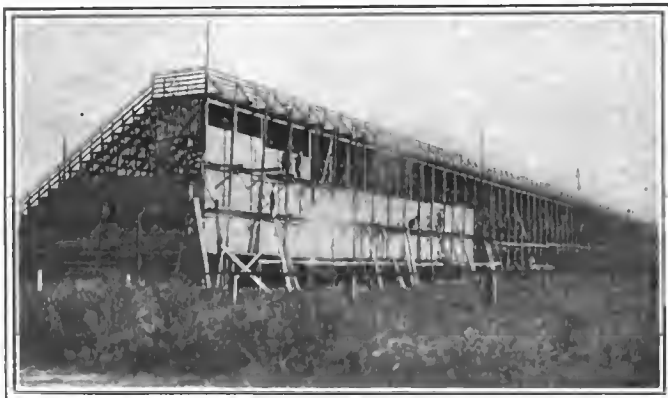

To prevent discomfort in the stands they are being boarded up behind



Banking the sharp turn to the grand stand, which was flat last year

## Grand Prize Looms

SAVANNAH, GA., Oct. 29—Preparations for the four great road races to be given here November 27 and 30 are progressing rapidly. Within two weeks it is expected that the circuit will be ready for fast practice work and from then until the actual race days this city and the surrounding territory will be the focus of attention for the automobile world.

The course is being straightened and slightly shortened by the elimination of certain curves and turns that were present last year. The total length of the circuit will be almost exactly 17 miles, whereas before it was about 18 miles.

Turns are being banked so that it only will be necessary to shut down on two of them at the most. The engineering problems involved include lengthening and softening the angles, widening the roadway at the approaches and raising the outside edges of the course on the turns so that the chances of skidding will be minimized. In several cases crooked portions of the course have been cut out altogether by building new roads through the woods, connecting up the good stretches in satisfactory form. As a general proposition the narrow stretches have been doubled in width and the average width of the course has been increased nearly 4 feet.

From end to end the surface has been repaved and when fast practice starts the drivers will find everything in the best of condition. The course resembles in a general way the route used last year, but the improvements that were outlined in a previous issue of *THE AUTOMOBILE* will go a long way toward insuring safety and stimulating high speed.

So far \$20,000 in round figures has been offered to the winners of the four races and before closing time it is expected that the prizes and purses usually hung up by accessory makers for winners and placed cars using their products will swell the total amount to over \$30,000. The Bosch Magneto Company has offered \$1550; Rayfield carbureter, \$2500; Remy company, \$4250, besides the purses of gold hung up by the Savannah Automobile Club, totaling \$12,500.

The Vanderbilt Cup race and the contests for the Tiedeman and Savannah cups will be held November 27. The Grand Prix will be staged on November 30.

The conditions of the races are as follows: Vanderbilt Cup: Open to cars under Class C, divisions 4C and 5C that is, non-stock cars with piston displacement respectively of from 301 to 450 cubic inches and from 451 to 600 cubic inches. The conditions of Class C are that the factory shall have made at least fifty automobiles within the preceding year, not necessarily of the same model. The purpose of the rule is to bar out freak cars.

The distance of the Vanderbilt Cup race will be 289 miles, or seventeen circuits of the 17-mile course. The prize is the Vanderbilt Cup, a perpetual trophy which already has been contested for six times. The cup carries with it a cash prize to the winner of \$2000 and the Donor's Trophy for permanent ownership. The entry fee is \$500 for one car, \$750 for a pair and \$1000 for three cars, which is the limit for one make of automobile.

Until this year the Vanderbilt Cup races have been staged on Long Island over a course consisting of a portion of the Motor Parkway and country roads.

The Savannah Challenge Trophy, which includes a cash prize of \$1000 and a Donor's Trophy for permanent ownership, is open to cars of Class C, Division 3C. This class includes cars having piston displacement of from 231 to 300 cubic inches, the next division below the smaller class in the Vanderbilt Cup race. The distance is thirteen laps of the 17-mile circuit. The entry fee is \$250 for one car, \$400 for two and \$580 for three.

The Tiedeman Trophy race for the perpetual trophy of that name and a cash prize of \$1000 is for cars of Class C, Division

## in Near Prospect

2C, cars having a piston displacement of from 161 to 230 cubic inches. Entry fee is the same as for the Savannah cup. The distance is 170 miles or ten circuits of the course.

The Vanderbilt Cup, Savannah Cup and Tiedeman Trophy races will be run coincidentally on November 27. After they have been finished the racers will prepare for the greatest of all the free-for-all road races in the automobilic world, the Grand Prize of the Automobile Club of America. Twice before has this contest been held and in each case a foreign car has borne away the honors. It has produced two of the fiercest speed battles ever witnessed and both times was won by the narrowest kind of margins.

A giant Fiat driven by Wagner won the first race and a Benz car piloted by Bruce-Brown went over the line less than 2 seconds ahead of the second car last year.

The contest is so framed as to attract the most powerful automobiles in the world, irrespective of their place of manufacture. It is free for all in a broad sense, the conditions of eligibility being extremely simple. They are as follows: No other agent of oxidation than atmospheric air is permitted. Each car must carry two persons seated side by side. Each must have a motor-driven reverse gear. Its exhaust must not be directed toward the ground. It must not be over 74 inches in width.

The entry of more than three cars of any one make will not be received and the entry fee is \$1000 for one car, \$1500 for two and \$1750 for three.

There is no restriction as to size and power except that the cars will have to pass an examination at the hands of the Technical Committee touching their safety and that they may not measure more than 74 inches in width.

The race is to be 408 miles long or twenty-four circuits of the course, and it will be run on Thanksgiving Day. Entries for all four races close November 15.

A provision is made in the entry blank covering each contest reserving the right to the racing organizations to refuse any entry or to stage a series of elimination trials if the volume of entries should prove to be cumbersome. While the actual entries to date are few and have not been announced, it is believed that there may be as many as ninety in the four races.

In such an eventuality it is quite probable that there will have to be some form of elimination in order to make the fields small enough for safety.

So far the entries include the following (unofficially): Case 2, Fiat 5, Benz 3, Mercedes 3, Marmon 2, besides several others.

The advance sale of seats has been much greater than ever before at this stage, and preparations are being made to care for vastly larger crowds than attended last year. The hotel accommodations must of necessity be scanty, as usual, but great effort is being made to arrange for quarters for the visitors. Accommodations suitable for housing and feeding 50,000 visitors for at least four days constitute a problem of much magnitude for a city of the size of Savannah, but the committee is relying upon the Southern spirit of hospitality to come to its aid.

The problem presented is much more momentous than last year because of the gap that intervenes between the running of the Vanderbilt Cup and the light car races on Monday and the Grand Prix on Thursday. For a day it would be possible to camp out, carrying picnic eatables, but the idea of camping out four days in November, even in Southern Georgia, has its drawbacks.

The large hotel which will have a capacity exceeding that of any hotel existing now in the South, is not finished yet, and will hardly be so in time to accommodate the army of enthusiasts that will come to Savannah to witness the races.



5—New turn near Bona Bella, completed for this Fall's races



6—High speed will be made down Ferguson Avenue between the pines



7—The surface of the course is being repaved throughout the whole circuit



8—Another new turn, which will make La Roche avenue safer for the races

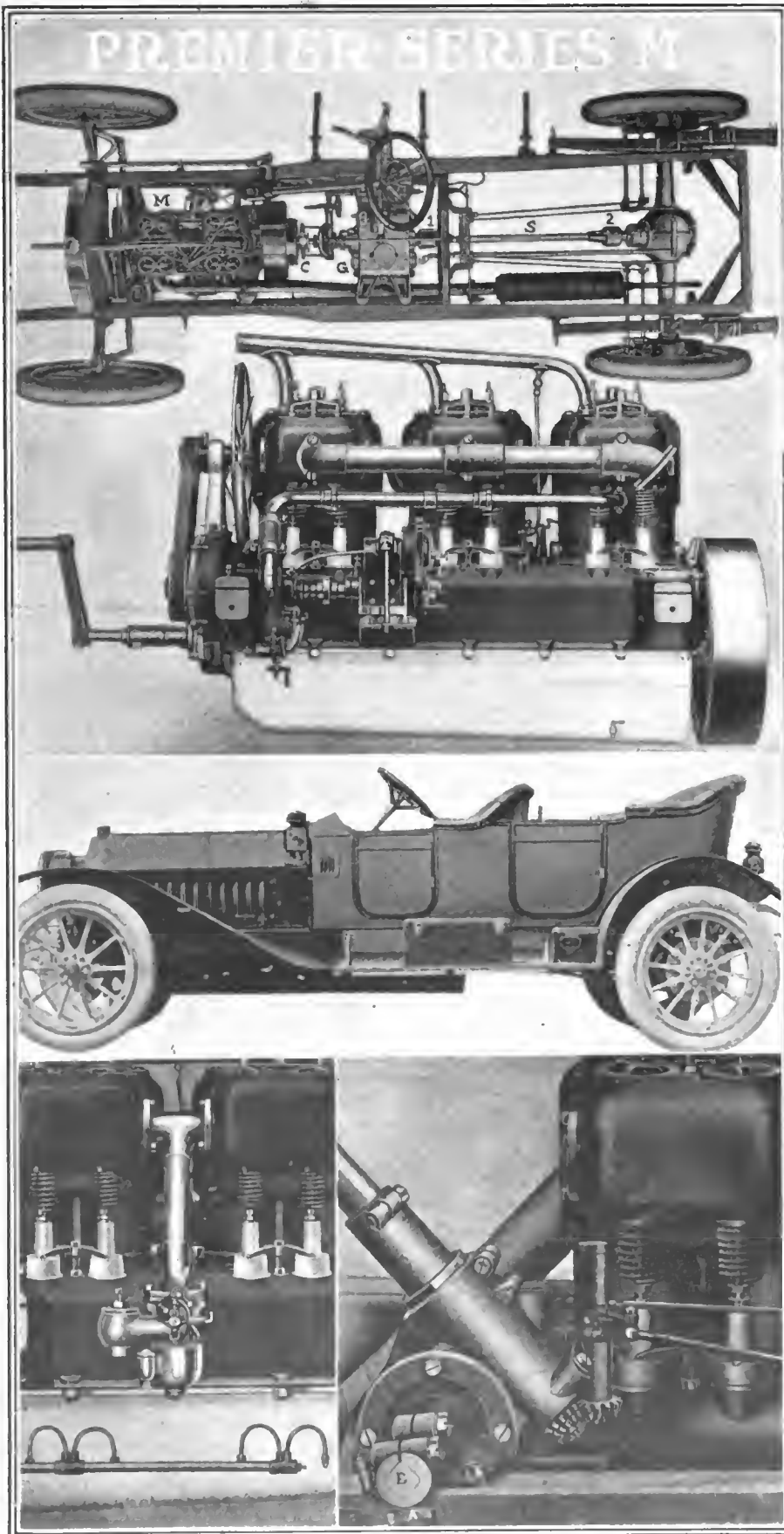

Fig. 1—Group of Premier Car Parts

In the upper illustration is seen the 1912 Premier four-cylinder chassis, showing the new style of brake equalizers. Beneath it appears the magneto side of the six-cylinder motor. The 1912 body styles is next shown. At the bottom on the left is the simple type of intake manifold on the four-cylinder motor and at the right is the steering gear mounted above the frame line so that the shaft E is carried over the frame side member instead of through it as is very frequent practice

**T**HE policy of the Premier Motor Manufacturing Company for 1911 will be continued for the year 1912. The company will build both four and six-cylinder chassis, the ratio of production being approximately four times as many six-cylinder as four-cylinder cars. The constructions of 1911 are continued except in minor details where changes have been made by the engineering department. In the motor the improvements are largely confined to the use of improved push rods and push-rod guides, for lifting the valve stems. The push rods are now made with rollers on their lower ends to bear upon the cams and the camshaft. These rollers will eliminate side thrust to a large extent. An improvement has been made in the oiling system by adding a lead from the sight feed on the dash to the bearing of the magneto shaft and thence to the timing gear housing at the forward end of the motor. Helical timing gears introduced in the early part of the 1911 season are continued.

The group of illustrations, marked Fig. 1, give a general conception of the Premier chassis, the four-cylinder type being here illustrated. The chassis is a three-unit type, the motor M constituting the first unit, and carrying in the flywheel the multiple-disc clutch C. The selective gearset G is the second unit. The rear axle comprises the third unit. Between the gearbox and rear axle is a propeller shaft S with two universal joints, 1 and 2. Between the motor and gearbox is a telescoping joint to allow for clutch disengagement. The motors whether of the four or six-cylinder type used the same twin cylinder castings of T-design, the bore being 4 1-2 inches, and the stroke 5 1-4. This is a stroke-bore ratio of 1.16 to 1. The motors are symmetrical units, having the carbureter placed centrally on the right side, and the water pump and magneto carried forward on the left side, a design which leaves all of the intake and exhaust valve springs accessible for removal if such becomes necessary.

Every care is taken in the manufacture of the motor, and one point which stands out in this respect is that the upper portion of the crankcase, instead of being an aluminum casting, is a close-grained semi-steel casting, which material is well adapted to hold the threads for the crankshaft bearings as well as the lower half of the case. The lower portion of the case, which serves the purpose of an oil retainer, is an aluminum casting. In the manufacture of the cylinder castings the cylinders are, after being cast, pickled to remove core sand. This done they are given a rough machining process and then heat-treated to relieve the tension of the outside scale. This process completed, they are bored, enameled and finally ground. The pistons, of gray iron, are each fitted with three compression rings. Connecting rods are I-section drop forgings and have large bearings. The crankshaft of the six cylinder Premier

is illustrated in the group on Fig. 2. It has four main bearings, whereas on the four-cylinder motor but three bearings are used.

The oiling system of the Premier is a circulating one, the complete details of which are shown in Fig. 2. In the top illustration is shown the oil pump P outside of the oil reservoir. It delivers the oil through a horizontal pipe to the six leads or branches 1, 2, 3, 4, 5 and 6. Each lead pours its supply into a trough T in the base of the crankcase, which is shown in the bottom illustration. On the bottom on each connecting rod is an oil scoop S which dips into the oil trough, picking up the oil, carrying a part of it to the lower connecting rod bearing and splashing a portion into the open cylinder. The oil which overflows from the troughs T drains into the reservoir to the pump, whence it is ready for recirculation. The size of the oil scoops S on the connecting rod caps has been experimentally calculated so that it is claimed they supply just sufficient lubrication without any tendency to induce smoking. Over each crankshaft bearing is a pocket which is filled by the splash, the oil leading from the pocket into the bearings. The oil reservoir, formed by the base of the crankcase, has capacity for two to three gallons at one filling, which is sufficient for 500 to 750 miles of road travel. To insure the driver as to the certainty of motor lubrication a sight feed has been placed on the dash. In addition to the motor lubrication there are various parts of the car, chassis, oil and grease cups, which take care of the gearset, rear axle, universal joints and other necessities.

Ignition on both four and six-cylinder Premier models is the conventional dual type, current being supplied by high-tension magneto. The simplicity of former years in the use of a simplified intake manifold is continued, the Premier Company being the first concern in America to use the simple vertical pipe from the carbureter to a point between the valve housings of the front and rear cylinder pair, as illustrated at the lower left corner of Fig. 1. This manifold calls for but a T-union between the cylinder castings, the remainder of the air passage to each casting being a water-jacketed space within the casting. The manifold employed on the six-cylinder motor, a Y-type, is shown in the upper illustration, Fig. 2. The use of manifolds of this nature adds to the accessibility of valve parts.

The clutch is of the multiple-disc type encased and running in oil. It is made of twenty-one plates arranged in alternate sets, ten in one and eleven in the other. Fig. 3 shows the general makeup and also illustrates one of the plates P with its cork inserts. These inserts are used to prevent gripping and allow of picking up car speed and drawing down to that of the motor without strain or shock on the mechanism of the car. The shaft between the clutch

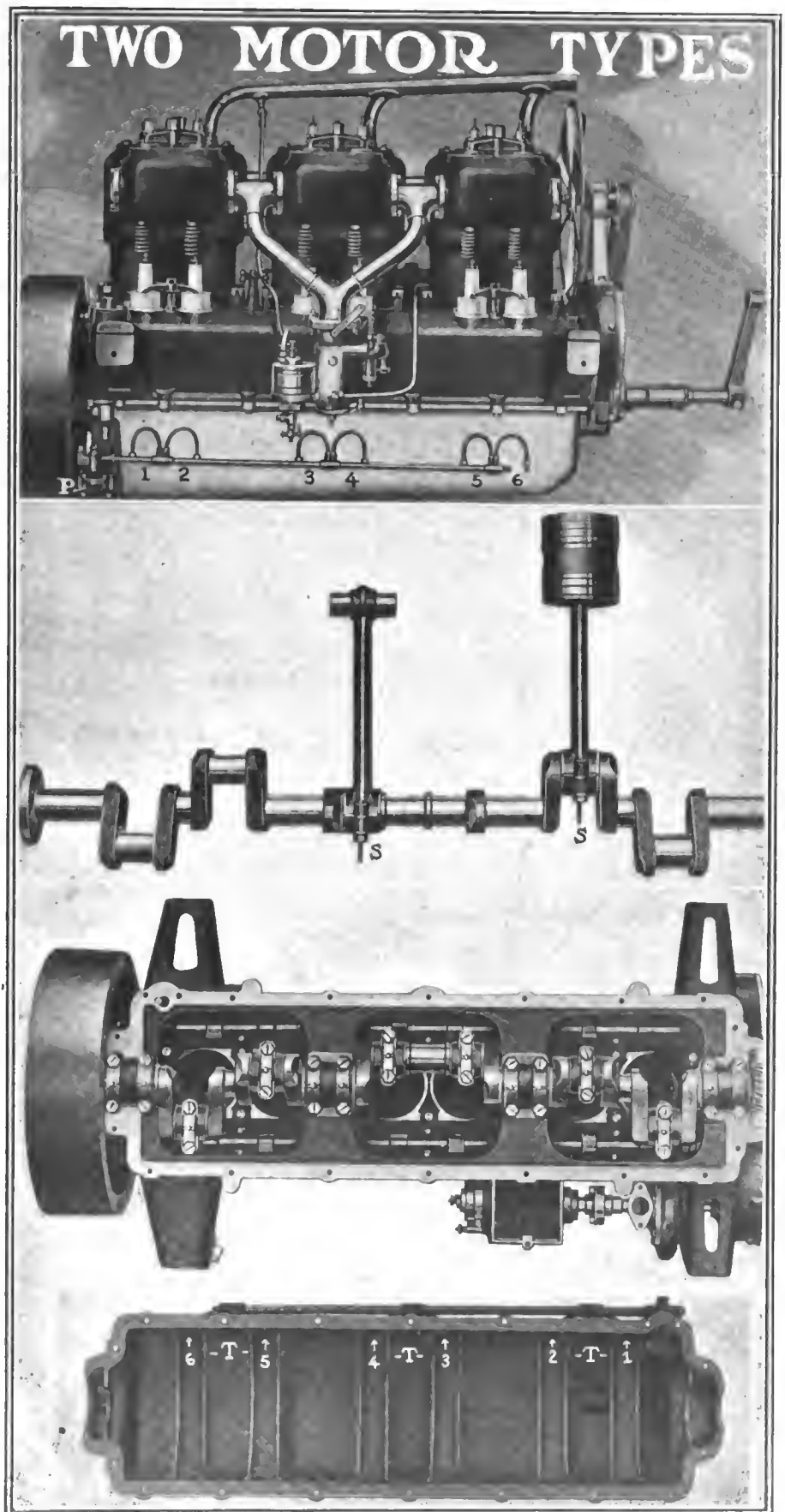

Fig. 2—Group of Premier Car Parts

This illustration shows at the top the intake side of the simple intake manifold used on this motor, a part of the gas passages are cored into the valve chambers in the castings. The second illustration shows the scoops on the caps of the connecting rods for oiling the bearings. The bottom illustration is of the inside of the crankcase base showing the six oil troughs into which the scoops S dip, the oil being fed into these troughs by means of the six oil leads marked 1, 2, 3, 4, 5 and 6.



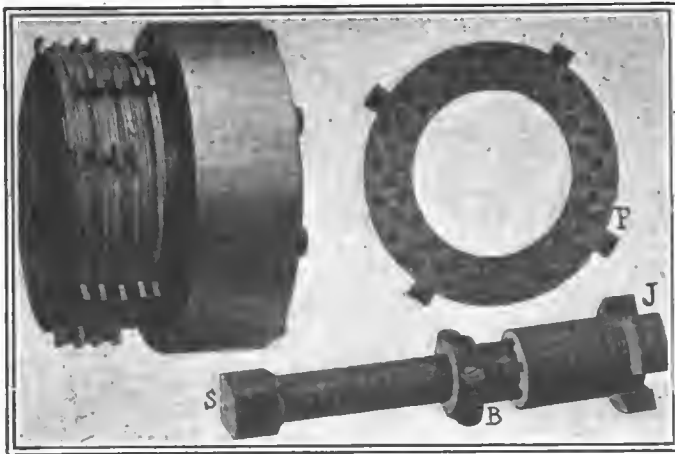

Fig. 3.—Premier multiple-disc clutch for 1912

and the greatest telescopes the part J with three jaw teeth extending into the gearbox and forming part of the direct drive clutch. This sliding member works on a shaft B with four broaches. The forward end of the shaft is squared at S, where it connects with the clutch mechanism. By the use of a releasing collar it is possible to remove any part of the clutch without dismantling the gearbox or the motor. The clutch release has been improved in that it now carries two annular bearings, one at the top and one at the bottom. The release consists of a bronze collar which carries these bearings, which work against hardened and ground steel discs. The release is claimed to be quite free because of the use of annular bearings and the bronze clutch plates being completely separated from one another by the use of steel springs between adjacent plates.

Nine years ago the Premier company on its original cars made use of a sliding gearset, a type now universally in the car field and one which has been improved upon year by year by the company. It is of the selective design, giving three forward variations. The design and location of the gearbox is illustrated in Fig. 4. It is an oil-tight aluminum case carried direct from the side members of the main frame. To carry the main and countershafts five imported ball bearings are used. The gears are cut from nickel steel forgings. At each end of the main shaft are positioned little plates on the shaft, so placed that by their centrifugal action they throw back upon the gears any lubricant tending to work out past the end of the shaft. This is an ingenious scheme to prevent the leaking of lubricant from the case.

Back of the gearset and connecting it with the rear axle is the propeller shaft with its two universals packed in grease. Each end of the propeller shaft is a tapered square which fits into a tapered square hole in the universal joint. This construction gives a positive connection with the proper amount of tightness. Paralleling the propeller shaft is a V-design of torsion tube, the spreading arms spanning the differential housing at the rear. The front end of the rod is retained in a spring cushion ball joint.

The Premier rear axle has always been a special feature in conjunction with these cars and is illustrated in Fig. 6. Each axle sleeve A is a tapered and slightly bell-shaped turned forging, and the differential housing G is a crucible steel casting. The axle housing is not supported by any truss rods, but has an internally ribbed housing which gives added strength. The axle drive-shafts B are carried at the inner ends on roller bearings and the outer end on a single annular ball bearing. On the axle drive-shaft is an integral clutch member C which locks with a corresponding clutch member D formed integrally with the brake drum. The construction of the clutch part D may be seen to advantage in Fig. 5.

The differential is of the bevel gear type and upon it is mounted the main driving gear, and through hand-holes in the rear of the housing the differential and the gear may be adjusted

laterally to take up any wear. Correspondingly, the pinion which transmits the rotary motion of the driving shaft to the floating axle gear is adjustable longitudinally, so that with these two adjustments the gears can readily be made to mesh properly should it be necessary to change their setting. There are eight anti-friction bearings in the axle, the roller thrust bearing on each side of the differential, imported annular bearings at each outer end of the axle shaft and four bearings in connection with the pinion, two of which are thrust bearings. The pinion is forged solid with the shaft, contrary to the usual practice of keying it. This construction obviates any danger of a loosened gear and gives a stronger one. The pinion is mounted between two imported annular bearings, an important feature and one much more desired than the common method of having both bearings on the front end, leaving the rear unsupported. The thrust is taken by two annular bearings with an adjusting collar to provide adjustment.

At the ends of the axle housing are the brake supports, rigidly attached and hot riveted so that they cannot loosen. The brake drums are integral parts of the wheel hubs not separable and bolted on. The live axle shafts are squared at the inner ends to fit into the differential. A liberal annular bearing is placed almost in the direct load-carrying center of each rear wheel, a construction made possible by the use of the semi-floating live axle. With this type of axle also the distance between bearings is about 24 inches, giving a large distance through which the supporting action against lateral strains takes place.

Some changes have been made in conjunction with the brakes in that the internal expanding sets are now steel bands covered with raybestos. Formerly bronze shoes with cork inserts were used. The external contracting brakes are steel bands lined with raybestos. A change has been made in the equalizing principle of these brakes in that short equalizers are used. (See Fig. 1, top illustration.) These equalizers are placed immediately in rear of the frame cross-member back of the gearset. For this year the equalizers were long members working in slots through the side members of the frame. With the new construction all of the brake operating parts are located within the side members of the frame. The two shafts for operating the brakes on each wheel are carried on the rear axle housing and in front of it. Adjustment of the brakes can be made by lifting the floor boards in front of the driver's seat. The brakes have a total area of 526 square inches.

In the Premier running gear the frame side members are heavily reinforced midway of the axles and the channel lips gradually taper to the rear. The rear corners are braced by pressed steel gusset plates and at the front are integral gusset plates which extend down to the radiator supports. The front springs are 36 inches long and the three-quarter elliptic rear ones have the bottom section 50 inches and the top section 26.

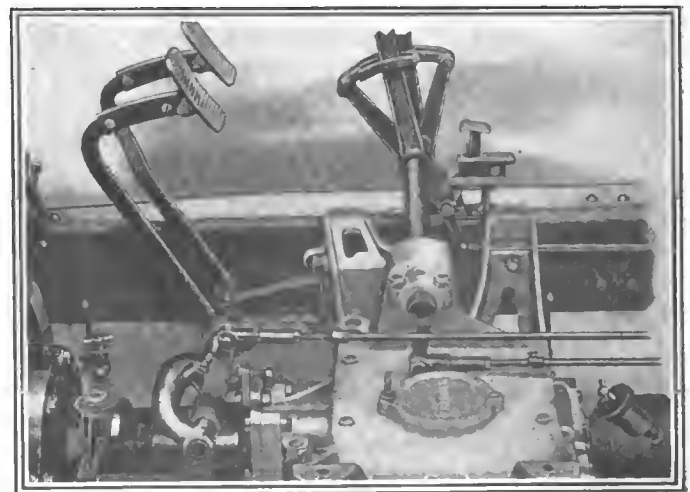

Fig. 4.—Gearbox and operating pedals on Premier



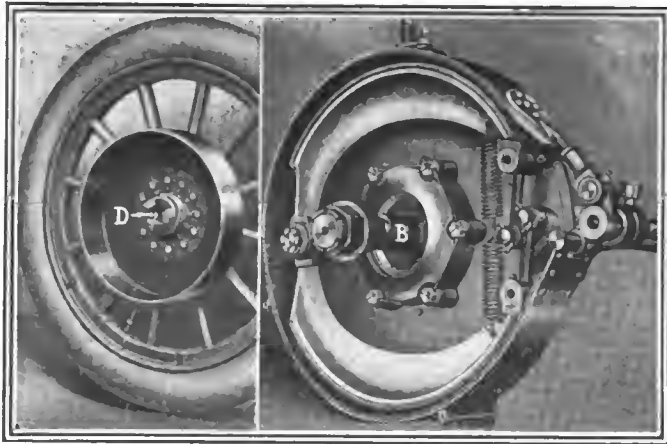

Fig. 5—Improved brakes on the 1912 Premier models

The front axle is a one-piece forging with Elliott-type ends. In the knuckle design the load-carrying center has been brought into the closest relation to a center line through a king bolt constituting the steering center. Thrust bearings are used in the top of the king bolt to carry the vertical load. The lower end of the bolt is held in hardened and ground bushings, the steering cross rod being placed in the rear of the axle. The front wheels are carried on tapered roller bearings.

The general location of the Premier steering gear is shown in the lower right-hand corner of Fig. 1. The bottom of the steering column carries a steel worm in mesh with a spiral gear which is carried on the shaft E. The shaft has a squared end and onto it is mounted the radius arm A, which extends downward and has a ball joint on its lower end. The shaft E is mounted in eccentric bronze bushings so that it can be adjusted with relation to the worm on the steering column. The gear on the shaft E travels less than one-quarter of its circumference for any movement of the steering wheel, and should this quarter become worn it can be shifted so that any of the three remaining quarters can be meshed with the worm, thereby increasing the wearing field of the gear fourfold.

One feature of the Premier body line is that the five and seven-passenger bodies are interchangeable on the four and six-cylinder chassis. In addition to regular touring body styles the 1912 line includes close-coupled types for four and five passengers, the Clubman design, and roadster styles. Inclosed types of limousine lines are included. In all the standard finish is blue black with black panel lines and light striping. The wheelbase on the four-cylinder model is 126 inches and that on the six-cylinder is 140 inches. Both chassis are fitted with Firestone demountable rims. Tire sizes on the four-cylinder cars are 36 by 4 1-2 all around, and on the six-cylinder chassis the front wheels carry 36 by 4 1-2-inch sizes and the rear wheels 37 by 5. This arrangement on the six-cylinder chassis gives a larger wheel tire, but it is a size which is interchangeable with the front wheels so that there is no necessity to carry a double supply of spare tires.

### Modern Rustproofing Methods

By the Bontempi rustproofing process, one of the latest along this line, the iron or steel article to be treated is placed in a muffle furnace and brought to a heat of about 1350° Fahrenheit, when dry superheated steam is introduced in the furnace and a cartridge containing certain chemicals is broken, also inside of the furnace, and the steam in combination with the chemicals forms certain gases which penetrate into the heated steel and impart to it a rustproof shell which is of greyish color and whose thickness depends upon the time of exposure. If it is desired to conserve the properties of the iron or steel article as much as possible, it is kept under cover, so as to protect it against oxidation from the atmosphere and cooled very slowly.

As this process practically involves annealing of the metal and, in the case of wire chains for example, has been known to reduce the tensile strength of the part considerably, it is scarcely applicable to automobile parts which have been heat-treated or hardened, and it is in fact quite possible, in the absence of tests in proof or disproof, that the process may weaken any part or article to which it is applied. On the other hand, the applications of the process are very numerous in other directions where the question of strength is subordinate to questions of surface and appearance. The advantages over sherardizing consist mainly in the coloring of the coat, which may be made black and matt black, as well as grey, by the use of oil on the heated surface, and in the fact that the active gases take effect in every nook and corner and particularly on the inside of hollow objects, while the tumbling process required for sherardizing cannot readily be used for any but smooth exterior surfaces and also requires considerably longer time. The company which is now erecting furnaces at Bridgeport, Conn., contemplates to experiment considerably before undertaking to recommend its process for articles employed for dynamic work, having a wide field where the rustproofing as such is the principal requirement. It is stated that articles treated by the Bontempi process resist attacks from acids and preserve their appearance indefinitely.

As one of the new methods by which other substances than carbon are introduced into iron and steel by cementation, and foreshadowing the time when all automobile parts may be machined in common soft steel and afterwards transformed into parts of great hardness and strength through the introduction of suitable alloys, whether these alloys penetrate the steel in solid or in gaseous form, the rustproofing and sherardizing processes claim the attention of automobile engineers.

### Honesty Best in the End

The feeling of distrust with which the average car owner looks upon the public garage has been discussed from various angles, and many owners naturally dread the idea of entrusting their cars and pocketbooks in the hands of those whose honesty has been so much debated. Nothing is so hard to regain as a lost reputation, and the short-sightedness of the few in the earlier days of the public garage business is much to blame for the existing conditions.

Restrictive legislation and the vigilance of the owners and garage proprietors, who have lost the idea that catering to a dishonest chauffeur is good business policy, have gone far in limiting the activities of the joy rider, so that on the whole the prospects are not so dark as they are painted. In the matter of repairs, the same may be truthfully said to be the case, although in this as in all other matters of purchase the energetic salesman will often have to be restrained.

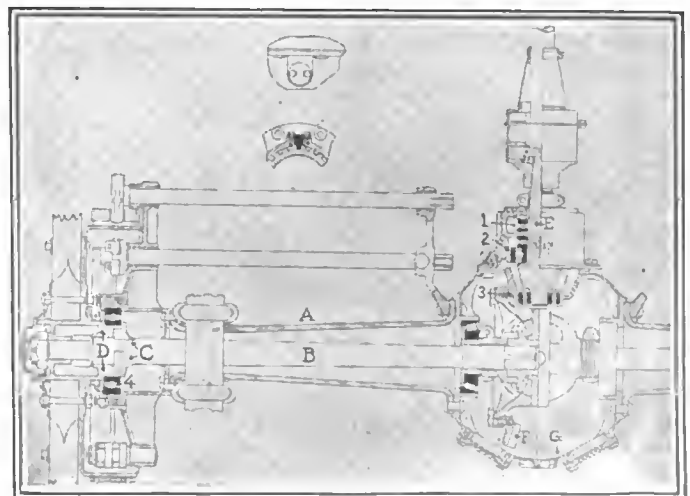

Fig. 6—The patented rear axle on the Premier

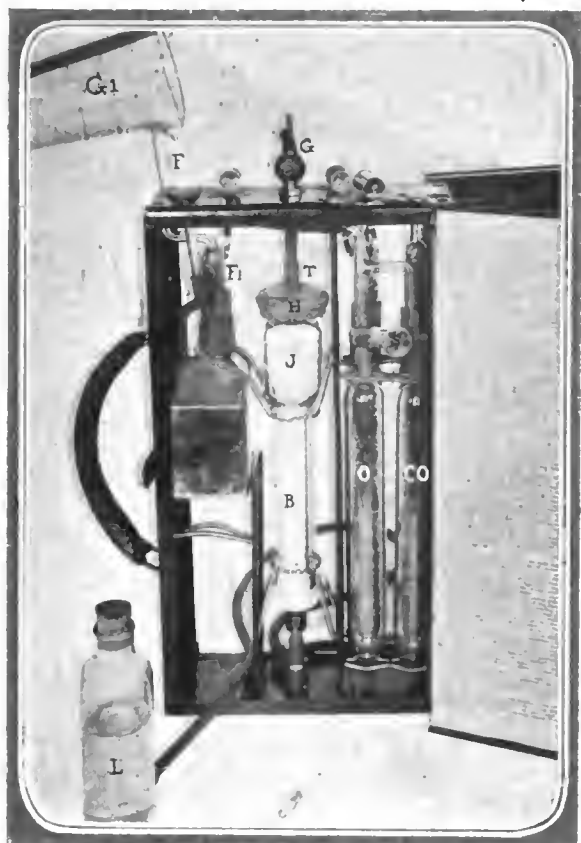

Fig. 1—Getting ready for the carbon dioxide analysis. The caustic is cautiously poured into the CO<sub>2</sub> chamber through a funnel, and the problem is not to spill any of the highly active alkali on either one's hands or clothes



Fig. 2—Regulating the level of the caustic potash. With the cock closed tightly and pinch check held wide open, the leveling bottle is manipulated so as to raise the caustic to the top of the metal filling above the CO<sub>2</sub> chamber

## How to Analyze the

**I**N order to get the maximum of work out of a motor, leaving all other things out of consideration, it is absolutely necessary that the mixture is right; that is, that gasoline and air are contained therein in a definite ratio, which, when the mixture is completely burned, will result in the motor's delivering the highest possible amount of power which may be realized from the quantity of fuel used.

The ideal mixture, according to numerous tests, contains about 14 volumes of air to one of gasoline. Gasoline, as is well known, is essentially a mixture of various hydrocarbons, prevalent among which is hexane, C<sub>6</sub>H<sub>14</sub>. This compound contains a fixed amount of energy per pound, which is set free and may be utilized if all of the carbon (C) and of the hydrogen (H) composing the hexane are burned to carbon dioxide and water, respectively. If the ratio 1 to 14 is diminished the gasoline will not be offered enough oxygen, and consequently part of it will escape unburnt or partly burnt, forming hydrogen and carbon monoxide. If, however, a mixture of a ratio higher than 1 to 14 is employed the surplus of oxygen will be of no use, and the additional amount of nitrogen which always accompanies oxygen in the air will go to stifle combustion and to decrease the rate of flame propagation.

Thus, a rich mixture will result in an excess of carbon monoxide in the exhaust of a motor, whereas too lean a mixture will produce an exhaust containing a high percentage of oxygen. In both cases the thermal efficiency is below the maximum. The maximum thermal efficiency is said to obtain at the ratio of 1 to 14.5. Some empirical results, compiled by a foreign expert, are given in the following table:

### RELATIONS BETWEEN THERMAL EFFICIENCY AND EXHAUST COMPOSITION

Thermal Efficiency.	Per Cent. CO <sub>2</sub> .	Per Cent. H.	Per Cent. CO.
.162	6.0	8.7	11.6
.204	9.6	2.65	6.25
.238	10.6	2.1	5.0
.244	10.9	Not determined	Not determined
.252	12.8	Not determined	Not determined
.261	13.5	Not determined	Not determined

These primary considerations will serve to carry conviction to the effect that the efficiency of combustion will react infallibly upon the composition of motor exhaust. Therefore this composition permits of drawing safe conclusions as to whether anything, and what, is at fault about the process of combustion taking place in the engine cylinders; it will also be a positive indication as to what means have to be resorted to in order to remedy the existing trouble; whether the motor needs a richer or leaner mixture, and whether the ignition is to be advanced or retarded.

The analysis of the exhaust is by far easier than it is generally considered to be; in fact, the necessary apparatus has to-day reached a state of development where no chemical knowledge whatever is required to do this work. There are several methods of making an analysis of a gaseous mixture, and the simplest one, which is sufficiently accurate for any tests the automobile user or engineer might be interested in, will be described in the following.

For analysis a sample of the gas to be tested is stored in a bent glass tube between two liquid levels and the space taken up by the gas is noted. After this has been done all of the gas sample is forced through a solution of caustic potash, which instantly absorbs the entire carbon dioxide content of the gas. Hereafter the gas volume is again measured and its volume noted. In order to determine the respective amounts of oxygen and carbon monoxide, the gas sample is first sent through a solution of pyrogallic acid, where the oxygen is absorbed, after which the rest of the sample is measured and then forced through a cuprous ammonia solution, where the carbon monoxide is held back. The rest of the gas which remains after this treatment is practically pure nitrogen.

The apparatus used in the analysis is the Hays Special Gas Analysis Instrument shown in Fig. 1. The apparatus is carried in a metal case (Fig. 5) finished in black and provided with a handle. The burette B,

## Exhaust of the Motor

which is surrounded by a water-jacket J, carries a scale and is connected, at its upper end, to a cock G, while a connection is provided at the bottom to permit of establishing a communication between the burette and the leveling bottle L, which normally is placed below the chamber marked CO<sub>2</sub> in the illustration. The CO<sub>2</sub> chamber has two upper outlets, one corresponding by means of a rubber tube to the cock G, while to the other outlet is fitted a short piece of rubber hose, into which fits a glass funnel F. In the connection between CO<sub>2</sub> chamber and cock G is interposed a glass tube filled with metal filings which retain all solid matter contained in a liquid passing through the tube. The cock G has also two other connections, which lead to two vertical glass chambers marked O and CO, which serve for the absorption of oxygen and carbon monoxide, respectively. Each of these chambers corresponds with a glass tube of the same volume on the opposite side of the instrument, and it is on that side that the connections from cock G lead to the tubes. On the side shown in Fig. 1, however, the O and CO chambers are connected through a T-glass tube and some rubber tubing, which is normally squeezed close by the screw clamp S.

The chemicals used for the analysis are seen in Fig. 3. Caustic potash is supplied with the instrument, this material being the most efficacious for the absorption of carbon dioxide. The potash is seen at S and S<sub>1</sub>, and it is important that in reordering the potash none should be bought which has been purified by means of alcohol. Pyrogallic acid, commonly called pyro, P and Pl, comes in small tubes, as does cuprous chloride, which is shown at C and Cl. Hydrochloric (muriatic) acid, H, is used in the analysis, because it does not react with carbon dioxide, monoxide or oxygen. At A is shown a bottle with ammonia solution, containing .90 per cent. of ammonia. Like the ammonium chloride, A<sub>1</sub>, it is used in the determination of carbon monoxide. The bottle B as well as glass funnel F also play their parts in the process. The aspirator A<sub>2</sub> is interposed in the rubber-tube line, about 6 feet from the end of the tube which is attached to the cock G.

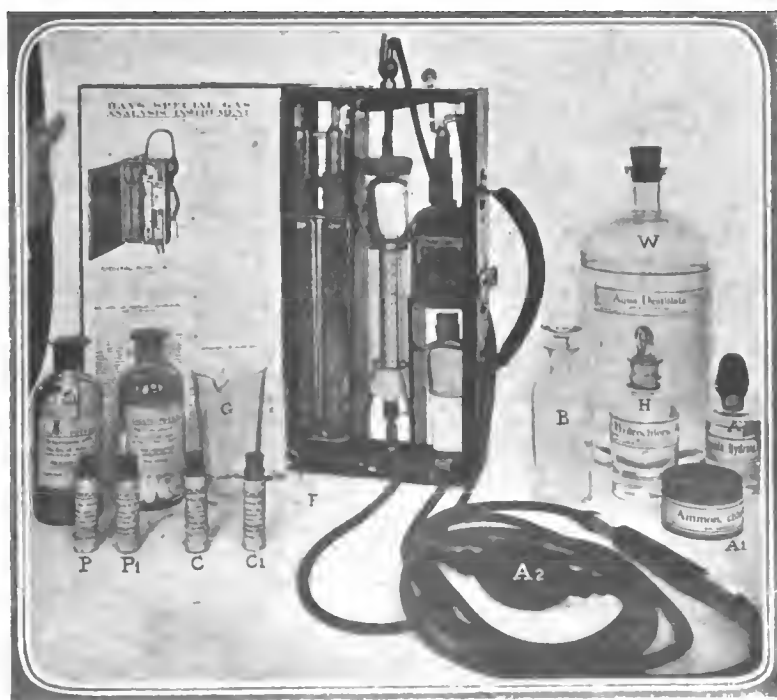

Fig. 3—Line-up of apparatus and chemicals for analysis. Preparations might look tremendous, but the operations are simpler than they seem. Besides muriatic acid and aqua destillata, only caustic potash comes into play when carbon dioxide is to be determined.



Fig. 4—Filling the burette with acid water. For this purpose the cock is turned open and the leveling bottle raised as shown in the picture. This operation is also used when it is necessary to coax the caustic into the chamber.



Fig. 5—View of the instrument when not in use. It is of first importance to remember that the cock should then be closed, and the plug be used to seal up the rubber tube above CO<sub>2</sub> chamber, lest disastrous results are the expectation.

Before beginning the actual analysis, the rubber hood H of the jacket J in Fig. 1 is lifted and the jacket filled with water up to the capillary tube T. Then the leveling bottle is filled to about two-thirds with distilled water, after which half a teaspoonful of hydrochloric acid is added. The leveling bottle should always be closed with the rubber stop furnished therewith, when not in use. The bottle being filled with dilute acid, one of the bottles containing the sticks of caustic potash is filled with distilled water, closed and shaken until the caustic has been dissolved. Then the handle of the cock is brought to a vertically upright position, and the funnel is put in place as in Fig. 1. Hereafter pinch check PC<sub>1</sub>—the one next to the CO<sub>2</sub> chamber—is pressed by two fingers, and the caustic having been filled into the measuring glass up to the 3 1-2-ounce mark, is poured into the CO<sub>2</sub> chamber. In case the potash should stay in the funnel and refuse to flow down into the chamber, it will be necessary to use the leveling bottle to attain the end sought. This is done as follows: First release the pressure on the pinch check. Then, after removing the leveling bottle from its compartment, the stop is taken out and the bottle raised. The hydrochloric-acid solution will flow from the leveling bottle into the burette and fill it. When the liquid reaches the height of the capillary tube, Fig. 4, the leveling bottle is held in place and the cock handle turned to a horizontal position. Now the bottle is lowered while the pinch check PC<sub>1</sub> (Fig. 3) is held open with the thumb and forefinger, until all of the caustic has flown into the CO<sub>2</sub> chamber. Then PC<sub>1</sub> is released. Now the instrument is ready for making one or more analyses for carbon dioxide.

The apparatus is placed in a stable position, preferably by hanging it on a nail through the hole in the metal casing. The funnel—or the plug which is put in the rubber tube above the CO<sub>2</sub> chamber when the instrument is not in use—is taken out of the tube, and the stopper removed from the leveling bottle. While the handle of the cock is still in the horizontal position, the leveling bottle is raised about 2 inches so as to drive any potash which may be in the connection between burette and CO<sub>2</sub> chamber back into the latter. The pinch check PC<sub>1</sub> must be held open while this is done. Now the cock handle is turned up vertically and the leveling bottle raised till the level in the burette rises up to the capillary tube. Then the handle of the cock is turned to a horizontal position, and, while PC<sub>1</sub> is still held open, the bottle is lowered slowly until the caustic rises to the top of the metal filing in the tube above the CO<sub>2</sub> chamber.

The apparatus is now ready for the gas sample to be introduced. For his purpose the long rubber tube carrying the aspirator is slipped over the open end of the cock, while a piece of 1-8-inch gaspipe is slipped into the other end of the rubber-tubing line. The gaspipe is inserted into the outlet of the muffler, and the aspirator worked. If this is done after the cock has been opened by turning the handle to a vertical position, the exhaust will pass through the burette and bubble up through the leveling bottle. This should be continued until the operator feels sure all the air has been displaced from the burette, when the cock should be closed by turning the handle to a horizontal position. Then bring the level of the liquid in the leveling bottle to the exact level of the zero mark on the burette. If the handle is turned up to an elevation of 45 degrees the liquid will rise slowly in the burette, its surface being curved downward at the center. When the lowest point of this surface reaches the zero mark the cock is closed. While the liquid flows into the burette the leveling bottle must be raised a little, so as to keep the levels in the burette and bottle the same at all times.

Then, while the pinch check is held open with the fingers, the leveling bottle is raised slowly until the liquid rises in the burette up to the capillary tube. This forces the gas sample into the CO<sub>2</sub> chamber, where all the carbon dioxide is instantly dissolved in the caustic potash solution. Now the leveling bottle is lowered quickly until the level falls in the burette down to the 15 mark. After this lower the bottle slowly until the caustic rises again to the top of the filling in the tube above the CO<sub>2</sub> chamber. When the potash has reached this height release the pinch

check and bring the leveling bottle to such a height that the levels of the liquid in bottle and burette fall into the same plane. The number found on the burette at the lowest point of the surface is the percentage of carbon dioxide in the gas sample tested.

Hereafter the rest of the sample may be tested for oxygen and carbon monoxide. For this purpose the respective chambers are filled with the proper reagents in the manner given in the instruction accompanying the instrument when it comes from the maker. These tests, however, take more time than the one for carbon dioxide, and the average automobilist is more liable to make a mistake while undertaking them. Incidentally, they are of less interest than the carbon dioxide determination, because what the engineer and autoist desires is a complete and efficient combustion, or, what means the same, a maximum of carbon dioxide in the exhaust. Therefore, it will be much simpler to work only with carbon dioxide analyses, adjusting the carbureter in one way or another, until the highest carbon dioxide percentage is obtained. This percentage is between 12 and 14 per cent., and on the average a motorist may be quite satisfied to run on a mixture that burns to an exhaust containing about 12 or 13 per cent. of carbon dioxide, because the degree of combustion prevalent in average automobile practice is hardly three-fourths of the one producing an exhaust with 14 per cent. carbon dioxide. At the same time it may be said that when the carbon dioxide content of the exhaust has risen to 13 or 14 per cent. the carbon monoxide therein is a very negligible quantity.

A few remarks respecting incorrect mixtures may not be out of place here. It is well known that gasoline is not explosive, and combustible only if mixed with no less than a minimum of air. This explains the possibility of burning gasoline in a lamp in the same manner as crude oil, and no spontaneous combustion will be experienced unless some of the fuel is permitted to evaporate and mix with the surrounding air. A spark occurring in a body of liquid gasoline contained in a tank will not be efficacious in igniting it, but will result in the most rapid combustion of the fuel if it is in the gaseous state and mixed with oxygen.

On the other hand too lean a mixture will not burn. Below a certain gasoline content the gasoline-air mixture is incombustible. This is well illustrated by the fact that not infrequently gasoline is spilled in the street and allowed to mix with air; at the same time, there are enough opportunities of igniting this mixture, so that according to the law of probabilities gasoline fires in the street should not be of such rare occurrence as they are in practice. The reason therefore is that the gasoline is rapidly distributed through the air currents always obtaining in a street, so that even a match lighted at a distance of say 10 feet away from the gasoline spilled will hardly ever ignite the same. Whereas in a closed room, such as a garage, the same experiment would undoubtedly result in a serious fire. A similar case can be observed in any city apartment every day. In a well-ventilated room, the gas of a lamp may have been turned on for minutes and plenty of gas might have left the burner; yet, if a match is applied to the burner, only the gas next to it will ignite, and the farther-away portions, which are mixed with a vast surplus of air, will not avail themselves of their opportunity to burn. In this instance, too, unless the room is well ventilated and the gas thoroughly diluted by plenty of air, a highly combustible mixture will be formed and ignited at the earliest occasion.

The apparatus before described is handy enough, and after having become accustomed to work with it by a dozen tests or so, the automobilist who is out for economy will find it a very convenient instrument. The construction is compact, and as long as the cock is kept closed and the glass plug in the rubber tube above the CO<sub>2</sub> chamber when the instrument is not in use, there is no danger of spilling any of the chemicals over the car as long as the glass parts of the apparatus remain unbroken, so that one may keep the analyzer in almost any place at all. It is manufactured by the Combustion Appliances Company, Rogers Park, Chicago, Ill.

## British Starting Crank

**A** CRANK which has been brought out in the English accessory market is described and illustrated with the assurance added that the crank has proved perfectly reliable in practice and is obtainable at a very reasonable price, besides that it may be fitted to any motor crankshaft by varying the bore of the motor shaft extension on which the crank is mounted. The description as given seems to be at variance with the possibilities of mechanics and is rendered in the following with modifications which, it is believed, represent the true construction of the crank. F is the motor shaft extension whose bore is fitted over the motor shaft end, not shown, and secured by set screws. This extension is cylindrical, and to it is keyed the pinion C. The crank arm B is journaled upon the end portion of the extension shaft with its hub adjacent to pinion C and fitting over it as a casing by means of a circular flange except where the crank arm joins the hub. A screw bolt holds a washer against the extension shaft end, thereby securing the crank hub B<sub>1</sub> while leaving it free to turn around. The free end of B is hinged to the piece A which forms the outer end of the crank arm with the usual handgrip, and the spindle which carries the grip is formed on the opposite side with a conical recess E<sub>1</sub>. D is another portion of the complete crank arm and is pivoted in B at D<sub>1</sub>. Its short end is provided with teeth which engage pinion C and its outer end is formed with a conical projection fitting into the conical recess E<sub>1</sub> in the end of A. A spring at the hinge joint A<sub>1</sub> holds A away from D and E<sub>1</sub> disengaged from E unless the hand of the operator starting the car exerts an opposite pressure upon the grip.

When it is desired to start the motor, this pressure is brought to bear, and the crank is turned in the same manner starting cranks are ordinarily turned. In case of back fire, however, if the pinion C is rotated in the reverse direction, the shock of its teeth against the teeth on the short end of D releases the engagement at E and E<sub>1</sub> and throws D around the pivot pin at D<sub>1</sub>, thereby leaving the pinion and the motor shaft extension free to rotate, while the crank is released. Apparently the rapidity of motion caused by the pinion acting on a very short lever has much to do with throwing the conical joint at E out of action, while the angle of the cone in conjunction with the

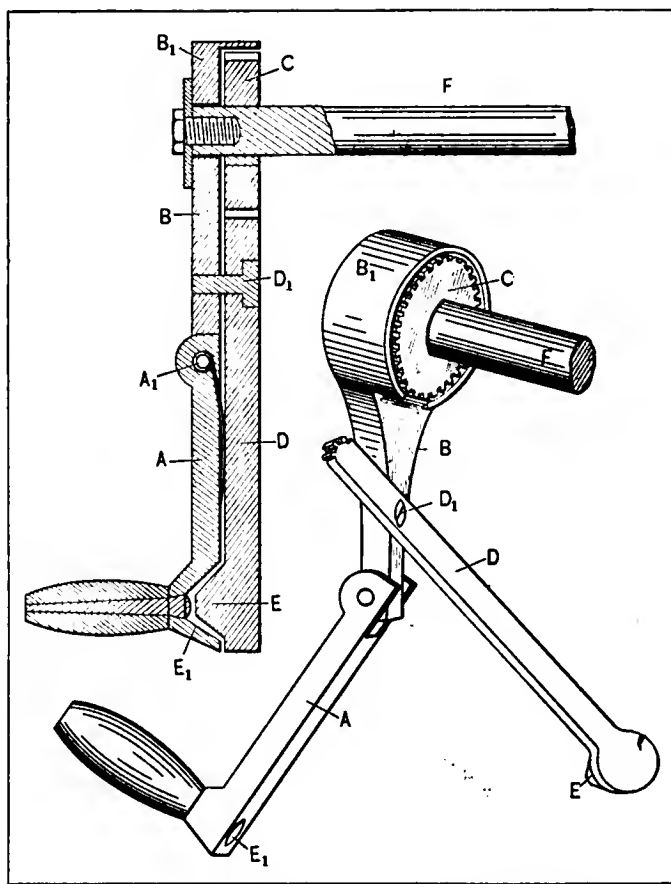

Safety starting crank recently introduced in England

spring at A<sub>1</sub> contributes to throwing A forward. The device can of course be mounted on the motor shaft with the customary clutch and release spring in addition to the features described, so that the successful starting of the motor will not throw the parts out of their normal assembled relations every time the crank is used.—From *The Motor*, Sept. 23.

## Harking Back a Decade

**J**UST ten years ago the *Motor Review*, the forerunner of THE AUTOMOBILE, published the following:

Alexander Winton created a new world's record for the mile on an oval track last week when he negotiated the Grosse Point track in 1:06 2-5. The best previous was Fournier's 1:06 4-5, made on Empire City track, New York. This record was made in the third mile of a 10-mile trial and was equaled in the seventh mile.

The list of exhibitors at the second annual display of motor vehicles, which will open in Madison Square Garden on November 2 under the auspices of the Automobile Club of America, includes the names of forty-one makers of automobiles and forty-two of accessories. Against the protests of the National Association of Automobile Manufacturers, the promoters decided to allow French cars to be exhibited.

Rochester, N. Y., is experimenting with the automobile for collecting mail, and its work as compared with that of the horse-drawn vehicles then in use showed a time saving of 61 per cent.

The Automobile Club of America pledged its support in the work of enforcing the new speed ordinances of Long Island. Secretary S. M. Butler, of the A. C. A., is especially prominent in the matter.

The necessity for the formation of a national association in

the interest of the users of motor vehicles is editorially dilated upon and attention is called to the fact that the Automobile Club of America has appointed a committee to consider the matter.

The Automobile Club of New Jersey is arranging to hold a hill-climbing contest on the famous Eagle Rock Hill on election day.

Boston announces its first automobile show. It is to be held in the new Automobile Building during the ten days from November 15 to 25. Admission will be free and after the regular show a permanent exhibition will be conducted.

New York motorists are congratulating themselves on the early completion of a specially built speedway for automobiles. It follows the windings of the Bronx River for 1 1-2 miles and will accommodate six cars abreast.

The Long Island Automobile Club is preparing for its race meet scheduled for November 16. In the entry blank gasoline carriages are divided into three classes: under 1000, between 1000 and 2000, and over 2000 pounds. Steam vehicles of all kinds are to compete in one class, as will electrics.

Two destructive fires marked the week. One, at the Chicago plant of the Woods Motor Vehicle Company, caused a loss of \$75,000. The other, at the new establishment of the New York Belting & Packing Company, also caused a large loss.



# Digest of the Leading Foreign Papers

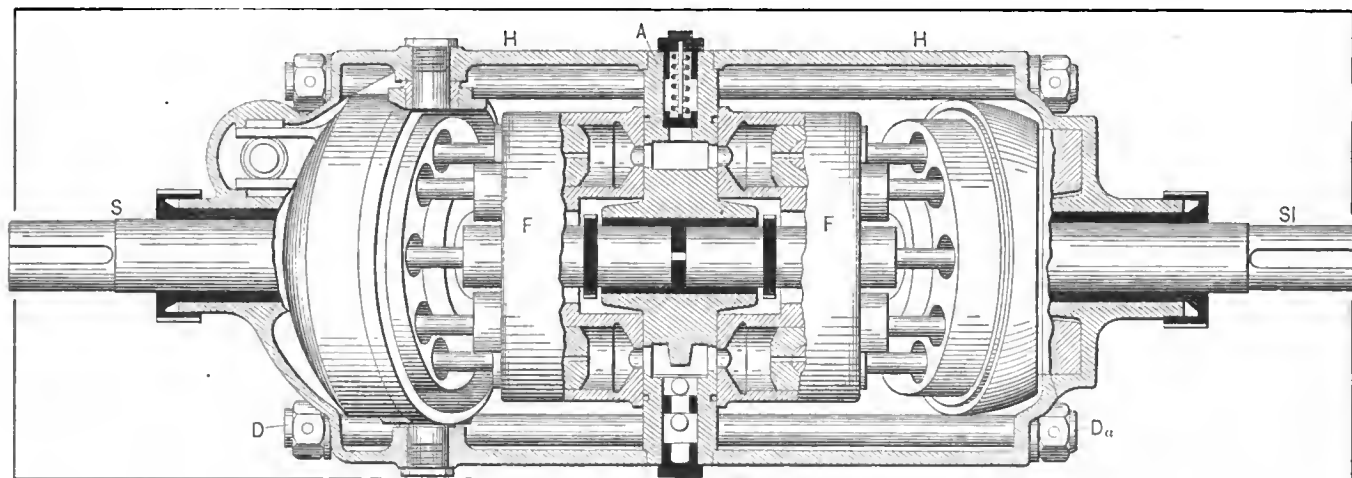

Fig. 1—Delaunay-Belleville hydraulic change-speed set in which oil is used

THE Williams-Janney hydraulic trans-

## New Hydraulic Change-Speed Set

mission and change-gear mechanism, which has been used for the maneuvering of turrets and large ordnance on board of warships, has been adapted to automobile purposes by the Delaunay-Belleville Company, of France, and is described by C. Faroux in a review of the foremost hydraulic transmissions, as these have become known through patents or practical applications. In all of them the principal object is simplification of the driver's control movements, the avoidance of gears and such reduction of the vehicle speed that a motor of moderate size shall be sufficient for moving a heavy load under the most difficult conditions of haulage so long as road adhesion is obtainable. The leading features of the mechanism are as follows:

The casing, Fig. 1, is formed of halves H bolted together against a central transverse plate A, called the distribution plate, in which there are two crescent-shaped slots (see Fig. 2). The motor shaft S enters one end of the casing through a packing box and abuts against a thrust block in the middle of the distribution plate, where a bushing in bearing metal is provided, and the driven shaft S, also abutting against this thrust block, extends through a long-packed bearing at the other end of the casing. Except as noted in the following, the parts are symmetrically alike on both sides of the central plate. A drum F keyed to the motor shaft adjacently to the central plate, is provided with nine cylindrical bores which register partially with the crescent-shaped slots in the central plate, except that each of the cylinder bores when at the top of the circle of rotation must register with the solid portion of the plate between the slots. In this drum nine reciprocating pistons, Fig. 3, are moved to and fro by means of piston rods actuated by a plate mounted upon the motor shaft by a cardan joint and held in an oblique relation to the motor shaft by its confinement in the ball-bearing ring, with large end thrust bearing balls in which it rotates. The adjustment of the cylinder drum on the motor shaft by means of rounded splines permits a certain play, two

helical springs secured to a pin through the motor shaft holding one end of the drums against the central plate when the mechanism is started. When the oil, which fills the whole casing, is under pressure in the cylinders, the drums D and the central plate are automatically held in contact because the interior pressure exceeds the exterior by virtue of the piston area exceeding that of the cylinders. The ball-bearing plate, on the motor side of the mechanism, may be placed at any angle between 90 deg. and 70 deg., as the ring or cup in which the ball bearings are mounted may be turned around pivot pins journaled in the casing by means of a control device consisting in a threaded rod actuating a worm. The adjustment screw passes through a packing and is operated by a lever from the outside. The ball-bearing plate on the driven side, on the other hand, is caused to rotate in a ring whose relation to the shaft is fixed permanently at an angle of 70 deg.

In operation, when the motor shaft rotates the drum on the motor side, the ball-bearing plate, rotated in its oblique ball bearings by the cardan joint and acting against the ends of the piston rods, drives the pistons in or out of the cylinders accordingly as the piston rod's attachment in the ball-bearing plate moves obliquely toward the distribution plate or away from it,

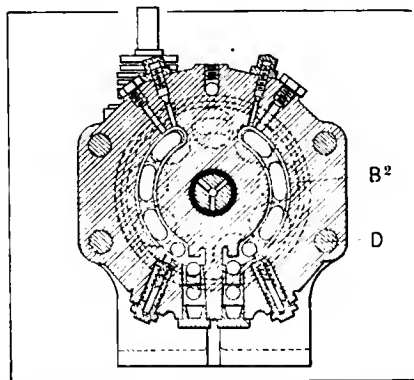

Fig. 2—This is an illustration of the central plate A, shown in Fig. 1, and shows this plate as seen from either end of the change-speed set. The two crescent-shaped slots spoken of in the text are seen, as well as the solid portion of the plate between ends of these slots

and these movements of the pistons on the motor side of the mechanism are transmitted through the oil in the cylinders to the pistons on the driven part of the mechanism, this piston movement in turn causing the driven ball-bearing plate to rotate in the direction which will make room for the piston movement similarly as a sailing vessel is driven forward, following the line of smallest resistance in the direction of its keel by a side wind, though the latter acts at right angles to this direction. The driven ball-bearing plate, of course, carries with it the cardan joint upon which it is mounted and thereby the driven shaft as well as the cylinder drum on the driven side. The speed of this rotation of the driven shaft is approximately the same as that of the motor shaft only if the motor

pistons are allowed full stroke, as in that adjustment of the ball-bearing plate on the motor side which is indicated in the illustrations. But if this plate is raised to a position more nearly parallel with the distribution plate each of the motor pistons will displace less oil for each revolution of the motor shaft, and the rotation of the driven ball-bearing plate will be correspondingly retarded, since the pistons on the driven side must always move with full stroke.

To effect a reverse movement of the driven shaft it is only necessary to tilt the ball-bearing plate on the motor side in the opposite direction, as this will reverse the piston movements and therewith the direction of the driven shaft's rotation. The solid portion of the distribution plate between the two crescent-shaped slots, Fig. 2, corresponds to one of the two periods in each revolution of the mechanism when a given angular movement in the rotation of the ball-bearing plate on the motor side is represented by only a negligible amount of travel for each piston, and the interruption of the oil flow through the slots at this point therefore serves to prevent uncertainty in the direction of motion communicated to the driven ball-bearing plate.

It is noticed that the only part of the oil which works in this hydraulic transmission mechanism is that contained in the cylinders and in the slots of the central plate A. The rest is not under pressure, but serves to lubricate all parts and to supply losses due to leakage, a reservoir with suitable valve passages to the casing keeping the latter full and taking care, as well, of expansions and contractions due to changes in temperature which may affect the oil and the casing unequally. Oil channels through the piston rods and pistons, which, however, are almost closed where the end of the rod abuts against the bearing socket in the ball-bearing plate, serve to remedy irregularities which may arise if some of the working oil in the cylinders is driven out under excessive pressures. These may occur in case of very heavy loads, when the ball-bearing plate on the motor side is adjusted to a low-gear position nearly parallel with the drum and the central plate. There may then be some escape of working oil between the pistons and the cylinder walls. It is evident that the walls of the central plate need not be parallel or close together. The space represented in the slots of the central plate may take the form of a long connecting tube and the driven part of the mechanism may be apart from and at right angles with the motor part. In principle the construction (and the patent) is relatively old and only the adaptation to it of modern ball bearings, highly accurate workmanship and a number of minor refinements, some of which may be discerned in the illustrations, have rendered it practical.—From *Bulletin*

*de la Société pour l'Encouragement des Industries Nationales* for May and *La Vie Automobile*, Sept. 23.

NO CONSPICUOUS AEROPLANE IMPROVEMENTS SHOWN IN FRANCE—At the competition for military flying machines taking place at Rheims, in France, the principal innovations in features of construction are the offset planes on the Maurice Farman biplane (so that the upper plane is not vertically above the lower one), and the improved starting and landing skids on the Coanda machine. For the military tests which relate largely to the carrying of loads, safe landings and starts from difficult—confined or rough—ground, the biplanes are considered much superior to the monoplanes. For speed the reverse is considered to have been established as true, for the present. Nearly all the motors have a considerable excess of power, to be used for emergencies only. In other words, it is recognized that no internal combustion motor can be normally operated at the extreme of its power capacity without incurring too many chances of breakdowns. The motors shown, in addition to the well-known Gnome, Renault and Anzani models, are the Clerget, the Chenu, the Dansette, which are modified automobile motors, and the Canton-Unne with radiating cylinders. To rise from a ploughed field by the shortest run and to reach an altitude of 500 meters in less than 15 minutes are the two performances under competition.—From *L'Auto*, October 13.

BENDS OF THE ROAD HAVE BECOME DANGEROUS to night-drivers since tar has been used as a dust preventive. Formerly the roadbed shone white in the light of the headlights, and, in case of a bend, the white streak was apparently interrupted fifty or sixty yards ahead, warning the traveler, but now the highways are black; the tarred surface simply devours the beams of the lamps and the metallized track seems to merge imperceptibly into the grass verges, and even the hedges that bound the roadway. When an abrupt turn is approached there is great difficulty in realizing the fact.—From *The Royal Automobile Club Journal*, October 13.

WHERE RAIN-WATER DRAINS FROM TARRED ROADS into fishing preserves, especially those in which salmon or salmon trout are hatched, great injury to fish life is said to result. The *Fishing Gazette* of July 8 reports a complaint from the Northern Anglers' Association relating instances in which damage was due to this cause and citing one case in which 17 pounds of poisoned eels were collected.—From a discussion in *The Royal Automobile Club Journal*, October 13.

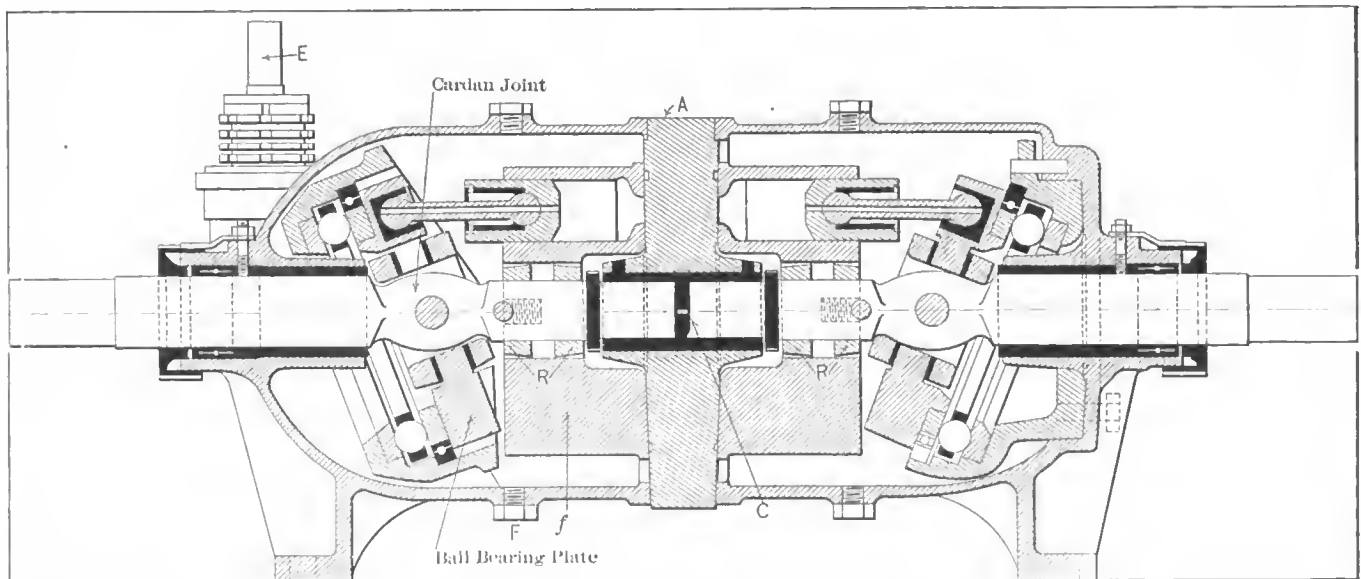

Fig. 3—This is a vertical section of the Delaunay-Belleville hydraulic change-speed set for use on trucks and lighter commercial vehicles. The central plate A is seen, also the ball-bearing plates mentioned so frequently in the text. The acts of pistons which work in cylinders in the drums D can also be seen, as well as the two cardan or universal joints spoken of

# Letters Answered and Discussed

## Has Carbureter Troubles

Editor THE AUTOMOBILE:

[2,889]—I am a subscriber to THE AUTOMOBILE, and would like some information regarding my car. I have a 30-horsepower automobile with a double-ignition system and single set of spark plugs. The car pulls very well on level ground, but as soon as I get on a hill the motor speeds up fairly well until I open the throttle wide, when it will suddenly stop without missing an explosion otherwise.

I have had the carbureter cleaned and adjusted for gasoline and air without results. I have also had the float shellacked and the gasoline pipe examined, but the carbureter will leak a short time after it is stopped. I have also had magneto points cleaned, and the other parts of the ignition system seem to be all right.

F. H. C.  
New Village, N. J.

The carbureter chokes when required to give a good supply of air when it is most needed. This can be remedied in two ways. First, by buying a new carbureter which has better auxiliary air adjustments; and second, to fit an air adjustment on the intake pipe which can be opened and closed by hand from the seat.

## Testing Spark Apertures

Editor THE AUTOMOBILE:

[2,890]—I have had considerable trouble with the ignition system on my car and have after considerable time come to the conclusion that it is due to the fact that the gaps in the spark plugs of two of the cylinders are too wide. How is it possible to test them for the correct distance between the two points?

I am sure the trouble is merely in the

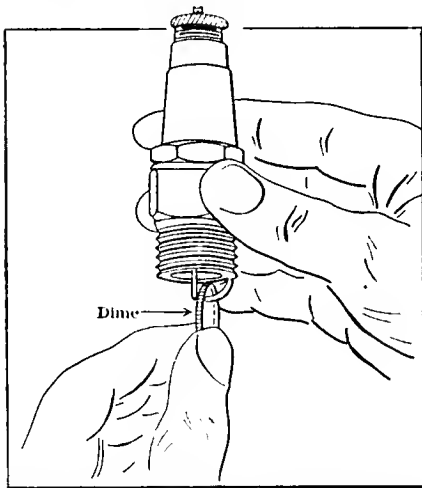

Fig. 1—Handy method of testing spark plugs to see if space between the spark plugs is of the proper width

spark plugs, for if I take the other plugs out and put them into these cylinders, they will fire all right. I was about to purchase new spark plugs, but thought that I would ask you if it would be anything besides the spark plugs which would cause trouble of this nature.

T. T. T.  
Hot Springs, Va.

It is a very simple manner to squeeze the spark-plug points together with a pair of pliers. A good method of testing the spark plugs is to take a dime as shown in Fig. 1. If the gap is too large, the dime will pass between the two points.

## Locking Turnbuckles

Editor THE AUTOMOBILE:

[2,891]—Would you kindly tell me if you know of any method of locking turnbuckles so that the vibrations due to the engine or

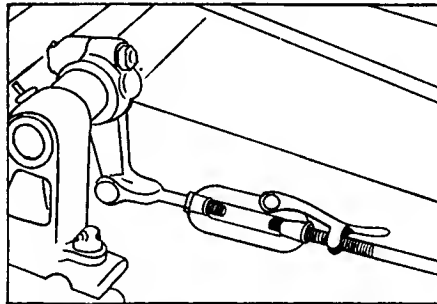

Fig. 2—Showing a simple method of locking turnbuckles

road will not alter the adjustments upon them?

The turnbuckles on the brake equalizers come out of adjustment after I have been running for a time, and if there was some simple method of locking them which I could install upon the buckle myself I would greatly appreciate it if you would tell me how it is done.

B. BUNN.  
Carthage, N. Y.

A simple method of installation is shown in Fig. 2. The clamp is merely turned back and holds the threads on the rods by means of corrugations in its jaws. A spring or other device may be fitted to keep it in position.

## Information on Farm Motors

Editor THE AUTOMOBILE:

[2,892]—In your issue of October 19 you have an article on motor farm machinery. I refer to the article on page 674. Can you inform me where I can get descriptive matter on the machinery therein mentioned together with prices. I am interested in motor machinery for farm use and will be

greatly obliged for any information you can give me. Very sincerely yours,

Fitchburg, Mass. THOMAS CASEY.

The C. I. M. A. tractor is made by the International Harvester Company of France, just like those made by same company here. With regard to the others we would refer you to Association Française de Moto-Culture, 51 rue de Lancry, Paris.

## Wants Gasoline Information

Editor THE AUTOMOBILE:

[2,893]—Would you be so kind as to answer the following questions:

(1) What grade of gasoline should I use to get the best results?

(2) How is it possible to determine the grade of gasoline from a given sample?

(3) What is the wholesale price of the different grades of gasoline?

C. R. PICKERING.  
Muscoda, Wis.

(1) The best results would be obtained with the lightest grade of gasoline, but excellent results are obtained with gasoline which registers 76 per cent. on the hydrometer test—the best grade of gasoline now in common use on the market.

(2) By means of the hydrometer, which is a very cheap instrument, and on sale at any supply house.

(3) The wholesale price of gasoline varies. At the present writing it is quoted at 7 cents per gallon in wooden barrels for 76 per cent. gasoline.

## Repair Broken Crankshaft

Editor THE AUTOMOBILE:

[2,894]—Being a reader of THE AUTOMOBILE, I would like to ask if it would be possible to have a broken crankshaft repaired that was made by a concern now out of business. These people have ceased making parts for their automobiles and hence I cannot have it replaced.

ROY L. MILLER.  
Bradford, O.

The crankshaft may be easily repaired, unless it is a hopeless wreck, by the autogenous or oxy-hydrogen welding process. Any firm who does this work will tell you if it is possible to repair your crankshaft.

## Kerosene in Radiator

Editor THE AUTOMOBILE:

[2,895]—Would you kindly tell a weekly reader of THE AUTOMOBILE what the result would be if kerosene were placed in the radiator instead of water?

FRANK CONE.  
Findlay, O.

The result would be that you would be

paying for your cooling fluid instead of getting it for nothing; that it would only cool your engine 87 per cent. as well as the same quantity of water; that various gases would be given off which would issue from any loose connections and that it would leak very easily. In short, it would not be very advisable to use it.

### Wants Heavier Flywheel

Editor THE AUTOMOBILE:

[2,896]—I would greatly appreciate it if you would answer the following questions through the columns of THE AUTOMOBILE:

(1) Is it safe and possible to increase the weight of the flywheel on my car, say about 15 pounds, without danger of damage to the engine?

(2) Where can I have aluminum castings made?  
A. W. MILLER.

Bound Brook, N. J.

It is not very easy to place additional weights on the flywheel owing to adjoining parts and other complications. But the counter-weights illustrated in Fig. 3 may be bolted on the cranks. If this is done the weights must be carefully distributed and arranged so that the balance of the engine will not be destroyed. In a four-cylinder motor with the cranks cast in pairs, there will be, as a rule, but three main bearings. In this case the weights should not only be distributed evenly among the cranks, but should also be balanced on either side of the center main bearing. The weight should add up to the total required. It must be remembered that when they are bolted so closely to the center of rotation, a heavier weight may be fitted than when they are at the rim of the flywheel. Fifteen pounds at the distance of a foot from the center of the shaft would be equivalent to 90 pounds at 2 inches from the center.

Any foundry will make the castings for you. If you consult a trade directory you will find the names and addresses of several.

### Wants Wiring Diagram

Editor THE AUTOMOBILE:

[2,897]—I have a 12-volt battery set, and wish to light two 6-volt lamps and also start the motor on the same batteries with four-section coil. Would you please give wiring diagram?  
SUBSCRIBER.

Indianapolis, Ind.

The wiring diagram is given in Fig. 4. As the coil will probably be wound for 6 volts, a 6-volt wire will have to be led from the battery set, on a separate switch from the lamps.

### Vanadium as Scavenger

Editor THE AUTOMOBILE.

[2,898]—The controversy with Mr. Lake has already taken up so much of your space that I am reluctant to further encroach. Mr. Lake assumes that the

prominent metallurgists I named as investigators of vanadium steel "have doubtless accepted Mr. Smith's statement that vanadium was a powerful scavenger." Possibly they have, although there is no evidence in any of their writings to that effect. My contention is not that vanadium does not possess scavenging value, but that this is not its main mission, and there is absolutely no evidence in any printed matter on vanadium by any competent metallurgist "that its main mission is as a scavenger." Mr. Lake says that of the metallurgists mentioned, J. Kent Smith was the only one who has specialized on vanadium, and that the property of vanadium as a scavenger "was the only statement that Mr. Smith emphasized." To refute this latter assertion I quote from the discussion on an address he gave before the Association of Licensed Automobile Manufacturers in New York City March 7, 1907:

"MR. ELWOOD HAYNES.—I would like to ask Mr. Kent Smith one or two questions. Secondly, whether it is essential for any of the vanadium to remain in the vanadium steel in order to give the special properties of vanadium steel?"

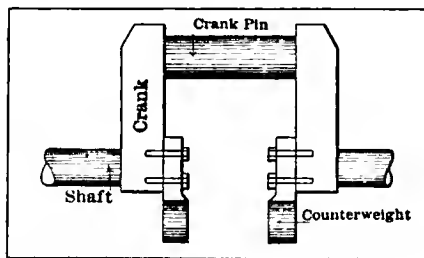

Fig. 3—Illustrating how counterweights are bolted on cranks

"MR. KENT SMITH.—With regard to the question as to whether it is necessary for vanadium to remain in the steel, I answer that strongly in the affirmative. Vanadium is an 'elusive' element. If there is any oxide left in the steel the vanadium will scavenge it out; but vanadium is an expensive scavenger. You want your vanadium left in to both statically intensify and to give dynamic quality to the metal."

Dr. Mathews' very favorable comments on vanadium steels before the Franklin Institute were made more than a year later than his talk with Mr. Lake, and after he had the opportunity to investigate and test out vanadium steels himself. Possibly Dr. Mathews' criticism was directed more towards Mr. Lake's handling of the subject. Dr. Mathews' opinion of vanadium steel is still the same as it was in 1909 when he delivered his lecture at the Franklin Institute. Mr. Lake stands alone and opposed to the experience of the steel makers who have made thousands of tons of vanadium steel, when he says that "its main mission is that of a scavenger." When he says, "I might say I know of none who have said that the main mission of vanadium is not that of a scavenger," he seems to be ignorant of the literature on the subject, for there is absolutely nothing published to warrant such a statement.

GEORGE L. NORRIS.

Pittsburg, Pa.

### Broken Valve Stem

Editor THE AUTOMOBILE:

[2,899]—I have recently been troubled with an inlet valve that broke on the road. Had it not been for a near-by shop I don't exactly know how I would have got home. Can you tell me of a way of repairing such damage on the road?  
J. O'DEA.

Jamaica, L. I.

You could have reached home by closing the inlet port whose valve is broken. It is also advisable to close the exhaust port to prevent scale and dirt from being drawn in through the exhaust pipe. The ports may be closed with a piece of thin sheet metal placed between the pipe and motor; or in some cases the valve lifter can be removed and the valve blocked down by removing the cap over it and placing something between the cap and the valve, putting the cap in place again to hold the valve down. It is generally better to have an opening into the cylinder after the ports have been closed, such as may be made by the removal of the spark-plug. After fixing this the engine will run on the remaining cylinder.

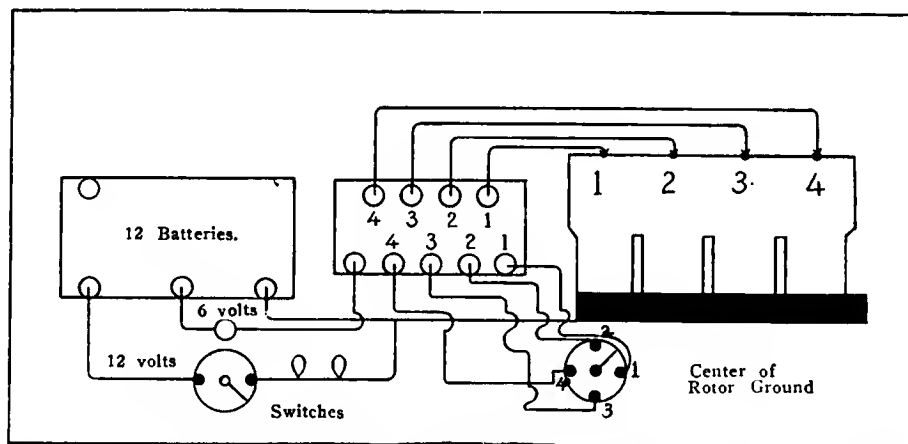

Fig. 4—Wiring diagram showing how to light two 6-volt lamps and start the motor on the same batteries

# Little Bits of Motor Wisdom

## Pertinent Pointers of Interest to Repairman and Driver

**M**EASURING THREADED PIECES—In the replacement of parts it often becomes necessary to measure the threading on a pipe or other part of the mechanism in order to properly describe to the maker the part desired. It is not always the case that a repair will be made by the service department of the company from which the vehicle was purchased, as there are not

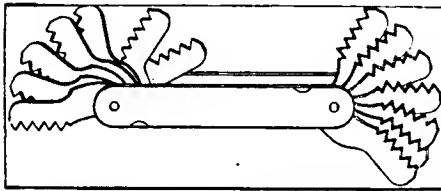

Fig. 1—Handy tool for measuring number and depth of threads

many people who maintain repair stations at distant points. In such cases the part will have to be sent for, and the long delay which accompanies the delivery by express or freight of heavy parts will have to be sustained. In many cases what would be a very simple and quick replacement for the service department or factory becomes a matter of very serious delay in the case of a person who is on an extended tour which carries him far from a place where speedy repairs or assistance could be expected.

The tour, even though it be extended, would have to be very exceptional if it was out of fairly short reach of a machine shop or a plumbing establishment. It might not be possible to reach such a place with the automobile in case it should have been completely disabled; but it would not be impossible to telegraph to the plumbing shop or machine establishment the nature of the piece required and have them be busily occupied in making it while the owner of the car either takes the train to the place of manufacture or awaits its arrival by express. If this is possible the wait will be merely one of hours for the repair instead of one which might necessitate an interval of several idle days.

It is not always possible for the amateur tourist to describe the part which he needs in language which is intelligible to the trained mechanic, who has a technical name for every contrivance upon which he works or every part which he turns out. But with the aid of the instrument shown in Fig. 1 the average car owner can, without an extended study of

machine shop practice and its accompanying details of technical nomenclature and other stumbling blocks in the way of the very excusably uninitiated, at least tell the thread dimensions on a threaded piece of material which needs replacement. A small tool of this nature is extremely handy, and this alone goes far in justifying it a place in the repair kit of the traveler who is going to make an extended tour, even if he starts out with a strong determination to cut down all excess baggage and weights which might interfere with the comfort of the passengers. But when the claim for space in the kit of the tourist is backed up by the fact that it might prove a friend in need, when the car is far from headquarters, it should at least be carefully considered before being thrown into the discard.

To measure the threads, the different leaves of the instrument are opened in the same manner as the blades of a pocket knife, and successively tried in the manner depicted in Fig. 2 until the proper blade is found. The number of teeth to the inch and the depth of the thread are marked upon the leaf of the tool and may be read off very easily. These dimensions are all that is required besides the specification of the shape of the thread, whether it is of V shape or whether it is square.

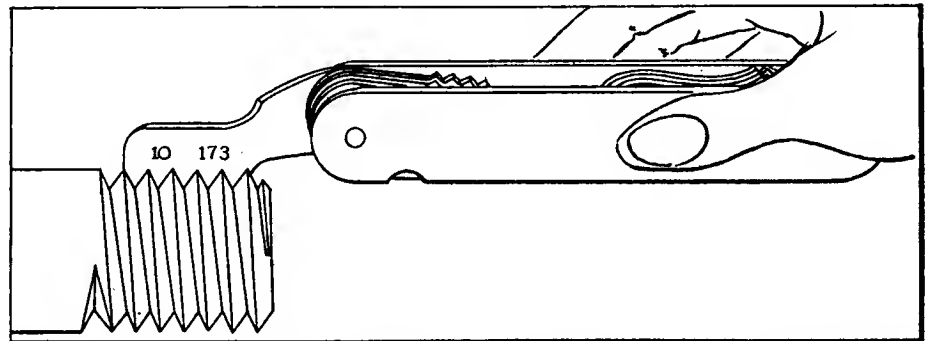

Fig. 2—Showing the manner of measuring a threaded bolt with a pitch gauge to ascertain size and depth of thread

If the style of thread be known to the operator all that would be required in amply describing the part as far as the thread is concerned would be to determine the number of threads to the inch by means of a steel rule or by any other rule which may happen to be convenient. The rule is laid upon the threads in the manner shown in Fig. 3 and the threads can be counted. In measuring the threads it is best to put the inch marks upon the apex of the thread instead of attempting to

measure the thread by putting the inch marks from root to root.

In case it is desired to measure the thickness of the shaft at the bottom of the threads it will be necessary to calibrate it by means of special calipers, called thread calipers, which are made for this special purpose—Fig. 4. The art of amply describing mechanical parts in language which will be familiar to the shop man is not a simple one to acquire. This is more particularly the case because localisms take the place of the true names of parts, and it is almost an impossibility for a machinist to understand all the terms of another who comes from a distant shop. In no case is this illustrated better than with the draftsmen of the different large machine shops in the country. A draftsman changing from one concern to another will often be put at practice work for the space of one or two months until he will have perfectly mastered the style and terms used in connection with the work at his new place of employment.

If this is the case with men whose profession leads them to study the delineation of mechanical parts and their various necessary dimensions it is very evident that it will necessarily trouble those to whom the more intricate details of the work in hand are unfamiliar. It is for this purpose

that special instruments, with which to determine the necessary and standard dimensions, are required. It may be the case that they will not be required once in three years, and again circumstances may be such that they will be found of frequent use. Standardization is only of recent years finding its way into the mechanical world, and confusion still reigns to a slight degree, although conditions are far better so far as interchangeability is concerned than they were a decade ago.



It is possible for the car owner who is equipped with these small but useful devices to go long distances with a feeling of security which springs from the knowledge that in case an accident should happen he is at least prepared to get out of it as gracefully as the circumstances will permit, and that the delays which accidents entail will be reduced to a minimum. It is not to be recommended to carry about

be hardly perceptible, will protect a tool to such an extent that the little trouble which it involves will be too small to consider. The oil may be placed upon a cloth in such a way that the cloth will be saturated. If the tools are then wrapped in the cloth they will be very safe from anything short of a deluge.

It is remarkable how tools and other metallic instruments subject to rust may be

ration which will defeat the effects of moisture the life of the tool will be greatly prolonged, and the necessity for a rigid examination at the start of every trip will be removed at least to a large extent.

**LOOSE EXHAUST MANIFOLD**—A peculiar wheezing sound which at times will almost approach a whistle may often be heard issuing from the motor. A search will often be made without results on account of the concealment of the source of trouble. It will usually be a safe guess that the sound issues from a point in the exhaust line where the piping has opened into a leak. As the gas under a pressure of 30 pounds, or thereabouts, rushes past the opening, a small amount passes through the opening, giving vent to the sound, which will often prove most elusive.

If a leak is found in the intake line it is not accompanied by the same noisy features that will insure detection of leaks in the exhaust line, but will be accompanied often by the blow-backs occasioned by a mixture which is too weak. The suction of the engine will naturally draw a quantity of air through the opening, thus diluting the charge and giving rise to the symptoms generally accompanying the lean mixture.

The chief cause of leakage in the exhaust line is the vibration of the engine, combined with the crumbling of the gasket, which keeps the joints tight while it is in good condition. In spite of the fastening which holds the flanges tightly together the constant shaking of the engine, which will be present, no matter how well balanced it may be, will cause the two flanges to work

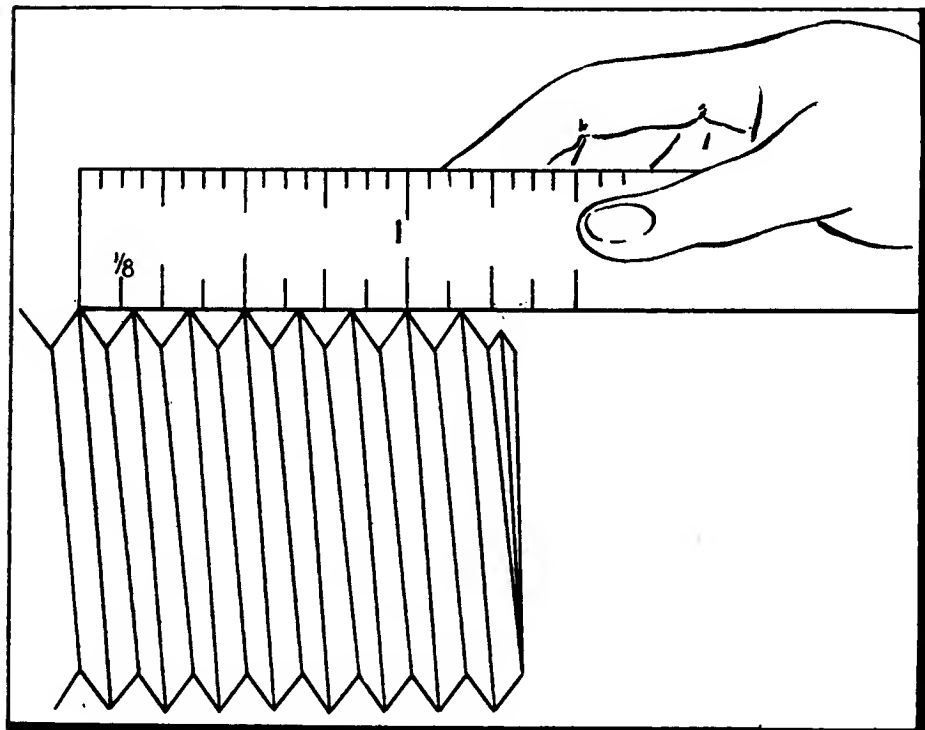

Fig. 3—Showing proper way to ascertain number of threads to the inch on a bolt

a quantity of loose material which generally receives the ignominious appellation of junk, but the small articles which may save trouble should be well considered.

**EXAMINE TOOLS BEFORE STARTING**—Besides carefully going over the finish of the car to see that it will do its owner credit on little trips around the country, it is extremely advisable to examine into the condition of the tools which are carried before starting out. There is no possible way of foretelling the conditions which may arise upon a trip even though it be of short duration. The best of cars will develop small weaknesses or derangements which may be readily cured by the use of the most familiar tools. If these tools are not in a fit condition to perform their work these small incidents will develop into annoying features which will spoil the pleasure of the tour on the most pleasant of days.

The chief enemy of tools is rust. Moisture, with its accompanying evils, will find a means of access to the tool kit if it is not very carefully sealed against the inroads of this enemy of most metals. A small coating of good oil, which can be placed so thinly on the metal that it will

ruined by the moisture carried in the air, especially near the seashore or in other places located near a large body of water, and hence carrying in suspension a great amount of aqueous vapor. In case the machine is to be left standing for any length of time in a neighborhood where it is likely to be exposed to the sea air, proper precautions should be taken not only to keep the tools in good condition, but also the other parts of the car which are not protected by paint or some other preparation to eliminate the possibility of oxidation.

The tools in a garage which is located in a damp climate will also require a considerably greater amount of care than those kept in a place which is high and dry. For this reason these tools require frequent attention and care in order to keep them in first-class shape. The cutting edge of a sharp tool, when examined beneath a microscope, will be seen to consist of a number of serrations similar to the teeth of a saw. When the edge is attacked by rust these small teeth are filled by the particles which gather upon the cutting edge of the knife or chisel, which is thus practically ruined. If the blade of the tool is protected by an oil or some other prepa-

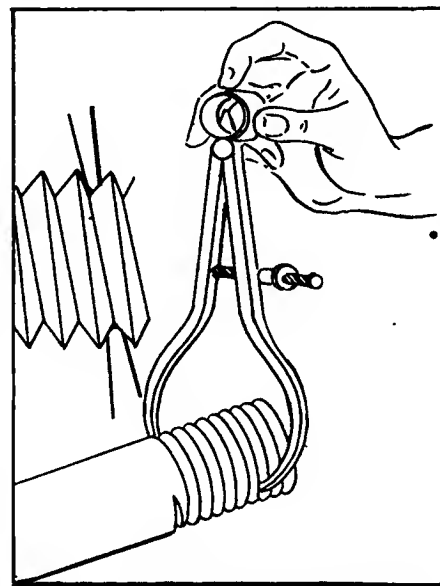

Fig. 4—Showing how to use calipers in determining the dimensions of thread

upon each other. This, combined with the high temperature present at this point in the line of the engine, will cause the packing or gasket to harden and eventually to crumble as the length of time it is submitted to wear increases.

# My Best Automobile Repair

## Some Quick Repairs Made in the Garage and on the Road

### Had Broken Steering Column

**E**DITOR THE AUTOMOBILE:  
In accepting your invitation to relate road experiences, the writer has selected a case which was quite serious, although it may not be classed as a "road repair" in the strict sense of the term. The repair was, however, made 225 miles from home and with such facilities as were available.

The accident, which happened on a very sandy stretch of road in Wisconsin about 3 miles from the nearest town, consisted of the steering column breaking off short and complete, carrying with it all control.

This steering gear (Fig. 1) is of the screw and nut type, and the screw has an integral extension 3/4 inch diameter extending about 4 inches into the lower end of shaft of steering wheel, and pinned to same by means of two 1/4-inch taper pins, B and C (Fig. 2). The extended portion of screw broke through first pinhole C, as indicated in Fig. 2, the holes being through center of shaft.

Upon examination of fracture it was found to be an old break which was continued to destruction, as shown at A.

The balance of steering gear was removed from car, which was left at side of road, and carried back to the town through which we had recently passed, in the hope of finding something that looked like a machine tool. In this the writer was partly successful, as a country tinker shop was found which contained a small lathe which

*Temporary automobile repairs made by the driver or owner while on the road and permanent repairs made in the garage after the run is over, are interesting to all automobile owners.*

*It may be a spring leaf has broken; a shackle bolt or strap may break; a steering tie rod is bent; the car skids into a curb and bends a steering arm or the starting crank; a throttle or magneto connection breaks owing to vibration; a radiator leak is started by a stone or some other means; a leak in the gasoline tank is discovered; there is a small hole in the gasoline feed line; a brake facing may burn out; a brake connection breaks; a front axle gets slightly sprung; a clutch starts slipping, or any one of a thousand things may happen.*

*Every automobile owner is interested in knowing how repairs have been made, how long it took to make them, how much they cost, and by whom they were made.*

*We want you to write in simple language in a letter what repair of this nature you have had to make, how you made it, how long it took you and how much it cost.*

*You can make with your lead pencil one or two rough sketches indicating the broken or damaged part and showing how the repair was made.*

*The experience of each reader is interesting to every other reader. Analyze your past experiences and send in one or two of them.*

*Give your name and address, legibly written. If you do not want your name to appear, make use of a nom de plume.*

*Editor THE AUTOMOBILE.*

would at least revolve. The man in charge of this place granted permission to use this lathe; thereupon, the gear was disassembled and the broken member drilled, as indicated in Fig. 3, and a piece of 3/4

common round iron G inserted and pinned in screw, as shown at I and I. These pins were ordinary wire nails. The other end was secured as before, except that straight pins, consisting of 1/4-inch round iron, were used, nothing else being available.

The whole was then reassembled and carried back to the car (on foot) and placed in position and connected up, the journey then being resumed. The total time occupied was 4 1/2 hours, cost \$2.70.

For the first 100 miles no chances were taken, and no avoidable strain put upon the repair, but as there was no evidence of weakness, confidence gradually returned, and car was run continually for 3 months with this temporary repair, and when same was finally removed for permanent repair, as indicated in Fig. 4, it was found to be serviceable. The permanent job was, of course, of proper materials and is still running.

This repair having been the most interesting one I experienced, I have related it alone here. Judging from the other quick jobs, which I have found occasion to execute, at some time or other, it seems to me that a repair may in a good many cases surpass the original piece in strength and serviceableness, at least for some time. It probably is not too rare an occurrence that the mechanical ability of the car user exceeds that of a designer, especially where some apparently insignificant details are concerned.

Chicago, Ill.

H. R. WILLARD.

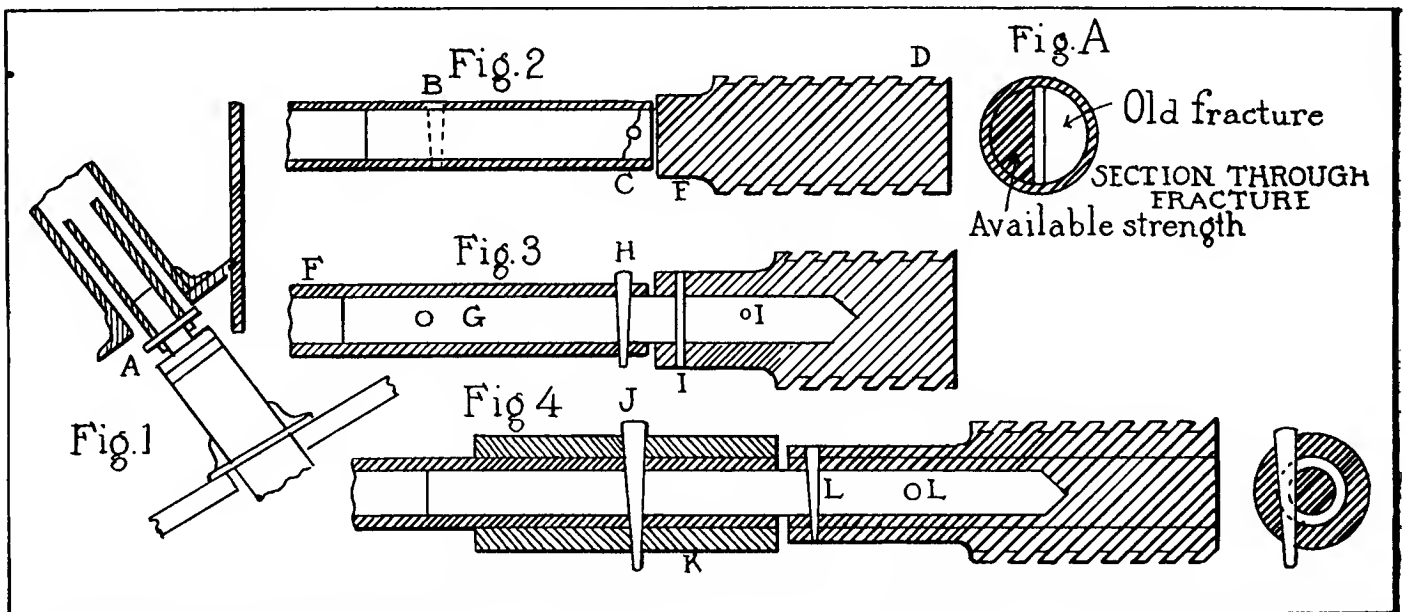

Fig. 1—Lower end of shaft of steering wheel. Fig. 2—Showing where screw broke through pinhole. Fig. 3—Showing how the broken member was drilled and round iron inserted. Fig. 4—Showing appearance of the permanent repair with a steel reinforcing sleeve

# My Ideal 1912 Automobile

## Readers' Conceptions of What Next Year's Car Should Be

### Specifies Underslung Frame

EDITOR THE AUTOMOBILE:

One important factor of an ideal motor car, in my estimation, should be its safety. To secure this I would specify an underslung frame, which has been time-tried, and has proven itself to be the safest construction.

The front axle should be a one-piece, drop-forged I-beam, and instead of having forked ends it should fit into forks integral with the spindles, thus weakening the axle in no way. The spring seats should be made integrally with the axle.

The cross-steering rod should be in the rear of the axle and be a drop-forged I-beam. The cross-steering rod, axle, spindle, arms and knuckles should be of chrome nickel steel and all wearing parts supplied with grease cups and simple adjustments. The steering gear should be of the worm and sector type, the housing being bolted to the frame. The steering column should be bolted to the motor sub-frame by means of a rod. The steering wheel, 20 inches in diameter, with a corrugated hard rubber rim, and with the spark and throttle levers fixed above it.

The motor should be a three-point suspension unit-power plant, six cylinders, cast in pairs of two, 4¾-inch bore, 6-inch stroke, 2-inch valves in head, with easily removable cages, four-bearing crankshaft, cams cut integrally with a four-bearing camshaft placed on right side of motor; valve tappets with rollers and fittings in the guides with a square fit, and the entire valve system, i. e., rocker arms, push rods and tappets, should have simple adjustments for wear. The pistons should be dome-shaped, having four rings and the wrist pins held in place by both.

The ignition system should be of the double type, magneto, storage battery and two sets of spark plugs placed on the left side of the cylinders. Also the magneto and the battery distributor should be on the left side, thus making the wiring connections very short. The magneto should be an Eisemann, with a non-vibrator coil, and the battery should have a vibrator coil, both easily removable for inspection.

The cooling system should consist of a Livingston radiator in connection with a centrifugal pump driven by the magneto and battery distributor gear and an eight-bladed aluminum fan driven by a worm gear.

The lubrication system should be a gear-driven pump contained in the lower half

of the aluminum crankcase (which is also the oil reservoir) forcing oil to all crank and camshaft bearings and the gears; and a constant level splash system for the crank and wrist pin bearings and the cylinder walls.

The gasoline system should be of a force feed type, with a pressure release, driving gasoline from a 30-gallon tank on rear of car, through a No-chammy strainer to a water-jacketed Rayfield carbureter (which has proven to me by experience that it can produce a perfect mixture at all speeds and under all conditions, and still economize on gasoline) placed on left side of motor.

The magneto and camshaft gears should have oblique teeth and be placed in front part of crank case.

The flywheel should be at the rear end of the crankshaft and enclosed in the unit housing. The clutch should be multiple disc, running in oil, with 26 steel driving plates and 25 bronze driven plates.

The gearset should be selective sliding and have three speeds forward and one reverse.

The steering mechanism should be on the left. The clutch and service brake, operated by left-foot pedal, and the emergency brake operated by right-foot pedal. In this way the change-speed lever is permitted to be in the center and it should not be operated in an H-slot but in a short cylindrical column, with a ball and socket joint, since the lower end of the lever would fit directly into slots in the gear-changing shafts. This control, along with a foot accelerator, should make one of the simplest controls.

There should be but one universal joint just back of the transmission, for the underslung frame would supply a straight line drive.

The rear axle should be floating and have a supporting member of one-piece drop forging, extending clear to outer ends of hubs. The center of this forging should be a large ring, in which the differential and bevel-drive would be supported on large ball bearings. On the forward face of the ring should be bolted a housing completely enclosing the tail shaft. A semispherical plate at the rear would encase the differential and by having a plug in it would supply a very accessible means of putting grease in the housing. By the removal of the above plate the entire differential and bearings could be removed. The axle shafts should have eight-jawed flanges which fit into notches on the wheels.

The supporting member should also provide bearing surfaces for swivel spring seats. The radius rods should be I-beam drop-forgings.

The front springs should be semi-elliptical, 36 inches long, 2 inches wide and 8 in number. The rear should be semi-elliptical, 56 inches long, 2½ inches wide, 10 in number and of the Packard type of connection of the rear end to the frame. All springs should be assisted by shock-absorbers and all spring bearings fitted with grease cups.

The brakes should be four in number, enclosed, internal expanding, 18 inches in diameter, 2 inches wide, giving about 452 inches braking surface, and all brake mechanism between frame members.

The wheels should be large enough to be fitted with 42 x 4½ I. D. tires, should have demountable rims and spokes of second-growth hickory. The front wheels should have 12 spokes, and the rear 14, each of which is bolted to the brake drums about 2 inches from edge of hub flanges.

The body should be a four-passenger torpedo, sheet-metal, with wood frame, fitted with 10-inch upholstery, trunk rack, running-board battery boxes and tool kit, and tire rack for two tires and rims.

The equipment should be: Combination Klaxon horn, compressed air starter, engine tire pump, complete set of tools, Warner speedometer and clock, Gray & Davis lighting system with side lights flush with the cowl dash, and mohair top and seat covers.

Wheel base should be about 124 inches.

This car should cost about \$4,000, as I agree with Mr. Louis Bourgeotte, in your issue of October 15, and believe that such a car as I have described cannot be built, with the best materials in all parts, such as silico-manganese steel springs, for less money.

FRANK R. SCHUBERT.

Barberton, Ohio.

### Wants Nice Little Car

EDITOR THE AUTOMOBILE.

Availing myself of your offer of outlining my ideal of a car, would say that I would prefer a small car for two passengers, roadster type, with fore-doors, about 106 inches wheelbase, with a motor permitting the car to go easy on say 20 miles an hour. I believe in a chain drive, live axle, 34 by 4 tires, and above all, high-grade workmanship and material. Such a car, if sold for \$500, could be manufactured by the myriad.

FRANK WHITNEY.

Buffalo, N. Y.

## Review of 1912 British Models

LONDON, Oct. 20—The first point that presents itself for consideration in regard to next year's cars is the matter of engine design, and the first subdivision of this section relates to the valve system. It is truly an extraordinary thing to find that after all the ingenuity and skill expended on the invention and design of new valve methods, the field is still left free for the poppets on one side and the Knight sliding sleeves on the other. As far as the sleeve-valve engine is concerned, its popularity is steadily increasing. The Daimler Company has not produced a poppet engine for 3 years, and the management declares that it desires nothing better than its present Knight engine. Incidentally, the Daimler output this year is the largest of any European firm. In addition, the following licensees of the Knight engine do a big business in Great Britain: the Rover Company, the Belgian Minerva, the German Mercedes, and the French Panhard. It would probably be correct to say that one car in every five sold has the sleeve-valve engine. This proportion is likely to be bettered next year, for two new licensees will be found in the Deasy Company, which has Mr. Siddeley, a leading British designer, at its head, and the B. S. A. firm (the gun and small arms factory), which will produce a small car of 14 horsepower, selling at about the \$1,750 mark.

But, while the Knight engine is popular with a big section of the community, it must be agreed that the present-day, poppet-valve engine, as made by the best firms, has had so much attention paid to the silencing of its details that it is, for all practical purposes, quite as silent in operation as the sleeve-valve type. Spring-actuated tappets, greatly reduced clearances, stout cover-plates across the valve mechanism, and other devices, have repaid their cost by the almost complete muffling of noise. The valves silenced, other engine noises have been disproportionately obtrusive, and the silencing process has had to be carried out right through the chassis, and even in the body-work. Hence, in the engine, the use of Morse-type chains is rapidly gaining for camshafts and magneto drive, and thus, often enough, the only gears in the engine are those inside the magneto. To quiet this accessory the Bosch firm will in future case in the whole of the gearing and contact breaker mechanisms.

To show what an effect the silent engine has exerted on general design, it may be stated that worm-driven rear axles have become quite general, particularly in cars under 30 horsepower; that chain-driven gear boxes have been tried by several firms (only one firm, Maudslay, has definitely adopted the system for 1912), and that all minor transmission details, such as the universal joints, have been redesigned, with lessened clearance. In the body work all loose joints or creaky places have been eliminated; in addition, rubber buffers are frequently inserted between the body and the frame members.

But, to return to engine design, it is clear now that the unit system of grouping together engine, clutch and gear box has disadvantages in the way of inaccessibility and greater expense of repair, which more than outweighs any mechanical benefits which result from this form of construction. Consequently, fewer makers announce this feature for 1912 than last year. As far as the combination of gearbox and rear axle is concerned, this being, apparently, a system much favored by the American designer, there is not any British car so constructed except the big Sheffield-Simplex car; this is styled the gearless car, in that it is claimed to be always started and driven everywhere on the direct drive. However, to comply with the law, a reverse gear had to be arranged, and at the same time an emergency low gear was provided. These speeds are housed in a forward extension of the rear axle casing.

Malleable iron is largely replacing aluminum for crankcase and gearbox construction, especially for small cars. Here the monobloc, four-cylinder casting is combined with the top half of the crankcase, the lower half being an oil pan made of aluminum or even of sheet steel. However, aluminum is very cheap at present, and therefore its use is not likely to be further diminished. Pressed steel construction has not made the anticipated progress.

Multiple-unit cylinders are increasingly common for fours, about half of the engines under 20 horsepower being of this type. Above this figure pair castings are usual, but for six-cylinder motors the two sets of three is the practice of the best makers. Single-unit cylinders are used by practically no one except Austin; it is curious how this designer, who was responsible for the Wolseley cars for 10 years until he established the Austin Motor Company, resolutely stands by the separate cylinder design.

The argument in favor of a bearing between adjacent throws of the crankshaft is well recognized, and one might safely say that about two-thirds of the best-known engines are thus designed. When a monobloc cylinder casting is used, five bearings are not possible, but three are considered the minimum. Crankshafts with but a bearing at each end are not favored even in the smallest powers. It is somewhat curious that in high-grade, six-cylinder practice there should be a marked difference of opinion. Some makers fit seven bearings; others of equal repute consider four to be ample; but, in any case, the crankshaft bearings and webs of a six are always made much stouter than those of a corresponding four, the actuating motive being not so much that of strength considerations, but the desire to reduce the periodic vibration trouble to the minimum. This complaint has been greatly in evidence since the engines have been quieted down so much, and on some cars the "thrash," or maximum vibration period, has been sufficiently objectionable to call for a radical cure. An effective remedy is provided by the slipping-clutch-flywheel device, fitted on the Rolls-Royce cars and also on the Daimler sixes. This consists of a disc clutch placed on the front end of the crankshaft and having as the driven member a heavy rim, which usually acts as the fan belt pulley. When the critical speed of rotation is reached it is found that the clutch slips somewhat, and this action has the effect of damping down the main vibrations which, if unchecked, would culminate in a very marked tremor. There cannot be any doubt as to the efficiency of this device; a run on a car with the clutch fitted and then with it removed at once demonstrates its successful action.

The subject of engine dimensions calls for some notice. British cars have, in general, smaller engines than American vehicles of similar price and intended for similar work. For instance, the average British four-seater has a 20-horsepower engine—not that there have been many 20's, but that this power is the mean between the two popular types of 15 and 25 horsepower respectively. As all engines are named by their tax rating (which is the S.A.E. formula of  $D^3 N \times 0.4$ ), it will be recognized that 3½ inches and 4 inches are the popular sizes for four-cylinder bores. Strokes vary from 1.4 to 1.8 times the bore. The average ratio for 1911 was about 1.5, but for 1912 this is likely to run out at about 1.7. This coming year, too, there are many small fours, with engines of the average dimensions of 70 mm. x 120 mm. rated at 12 horsepower. The bigger fours have each its corresponding six-cylinder model. Surprisingly popular are the sixes, particularly for the covered cars, and this demand shows no signs of abating. The leading makers seem to have no difficulty in obtaining an extra \$600 or so for a six-cylinder model. com-

pared with a four-cylinder of approximately the same power. Consideration of the transmission system indicates clearly that the leather cone clutch is further increasing its preponderance. The disc form is retained by a few makers, but other types, such as the internal expanding shoes or the contracting band, are being replaced by the leather cone. In not a few cases the cone clutch is enclosed, and the rubbing surfaces run in an oil bath. Increased attention has been paid to the flexible coupling between clutch and gearbox; this once potent cause of rattle and vibration has now been toned down to the silent level of the other components. A step in the right direction has been made by replacing the "sliding squares" joint by a double Hooke's coupling.

This year shows a general move in favor of the four-speed gearbox; hitherto, three forward speeds have been considered ample for all types, and therefore it is rather a reversal of previous tendency to provide the extra gear on small, medium, and large cars. The influencing factors have been the increased demands which are made upon the small four—that is, the owner of a 15-horsepower four-seater wants to average the same pace be increased—and, secondly, the desire to reduce the engine noise on the indirect gears. With two steps between first and top gear, the maximum engine speed is much less than where only a single intermediate gear is provided, and likewise the rotational speed of the gears themselves is reduced. Invariably, the top gear has the direct drive; the indirect fourth is no longer standard.

A fact in regard to gearsets is that roller bearings have not come into the general use anticipated. Ball bearings are almost universal, and not more than three firms pin their faith to the rollers. In connection with bearings it should be noted that, for engine construction, plain bearings hold almost undisputed play. Ball and roller bearings have proved too noisy, and the advantages gained in other directions were too slight to make them popular. With the effective systems of lubrication now universally employed, plain bearings (white-metal lined in all cases) give perfect satisfaction.

Lubrication systems under two chief types, with many less important variations. Many of the best known engines have pressure feed throughout; others of no less standing show a preference for the troughs-beneath-the-connecting-rods arrangement, where in the supply from the large base sump is pumped into reservoirs

beneath each cylinder and thence splashed to all the bearings. In this latter system it is the custom to raise the level of the trough and of the oil therein in accordance with the motion of the throttle lever, so that the supply of lubricant is increased in the same proportion as the load on the engine. It is a curious fact that no decided preference is shown for either the plunger or the rotary-gear type of pump.

A growing practice inclines the engine at an angle of about 8 degrees to 10 degrees, so that the crankshaft may be directly in line with the propeller shaft of the worm-driven axle and the working of the universal joints thus reduced. Of course, if the worm is placed above the worm wheel, the engine remains parallel with the frame, but by far the majority of makers favor the worm-below position. The chief merit of this arrangement lies in the fact that the worm has a copious supply of oil when the car is being started. When running, the lubricant is carried round by the worm wheel, and then there is little difference, as far as frictional loss is concerned, between the two types. It is at the moment of starting, however, that the greatest pressure occurs on the teeth, and, if at this time the surfaces are dry, wearing of the phosphor-bronze worm is inevitable. Worm drive is not universal, but more than half of the leading makes are so fitted. By dint of great care in the planing of the gears, of even more care in the hardening process, and by a final grinding of the teeth on special machines, the makers of bevels are now able to produce gears which are no longer open to the objection of noise. As far as transmission efficiency is concerned, the bevel has a slight advantage over the worm gearing.

A feature which is apparently exclusive to the British trade is the general popularity of the detachable wheel. Quite 75 per cent. of 1912 cars will be so equipped, half a dozen different types of wheels sharing the honors. The wire form of wheel heads the list. This was pioneered by the Rudge-Whitworth firm, but it is also made extensively for supply to the trade by Riley, Goodyear, and others. Some firms, like Humber, make their own detachable wire wheels, but the general custom entails the purchase from the specialist manufacturer. Besides this, the pressed-steel spoke is popular, its superiority over the wire form lying in its improved appearance and greater cleanliness. Where wooden artillery wheels are fitted, these are frequently detachable.

## Calendar of Coming Events

### Shows

- Jan 2-11.....New York City, Hotel Astor, Importers' Salon.
- Jan. 6-13.....New York City, Madison Square Garden, Twelfth Annual Show, Pleasure Car Division, Automobile Board of Trade.
- Jan. 6-20.....New York City, Madison Square Garden, Annual Show, Motor and Accessory Manufacturers.
- Jan. 10-17.....New York City, Grand Central Palace, Twelfth Annual Show, National Association of Automobile Manufacturers; also Motor and Accessory Manufacturers.
- Jan. 15-20.....New York City, Madison Square Garden, Twelfth Annual Show, Commercial Division, Automobile Board of Trade.
- Jan. 20-26.....Milwaukee, Wis., Auditorium, Fourth Annual Show, Milwaukee Automobile Dealers' Association.
- Jan. 22-27.....Detroit, Mich., Wayne Gardens, Eleventh Annual Show, Detroit Automobile Dealers' Association.
- Jan. 22-27.....Providence, R. I., Providence State Armory, Rhode Island Licensed Automobile Dealers' Association, Automobile and Accessories Show.
- Jan. 27-Feb. 10....Chicago Coliseum, Eleventh Annual Automobile Show under the auspices of the National Association of Automobile Manufacturers. Pleasure cars, first week. Commercial vehicles, second week.
- Feb. 5-17.....St. Louis, Mo., Coliseum, Annual Show, Pleasure cars, first week. Commercial vehicles, second week.
- Feb. 12-17.....Kansas City, Mo., Annual Show, Combined Association of Motor Car Dealers.
- Feb. 14-17.....Grand Rapids, Mich., Third Annual Show.
- Feb. 17-24.....Newark, N. J., Fifth Annual Automobile Show, New Jersey Automobile Exhibition Company, First Regiment Armory.
- Feb. 17-24.....Minneapolis, Minn., National Guard Armory and Coliseum, Annual Automobile Show, Minneapolis Automobile Show Association.
- Feb. 19-24.....Hartford, Conn., Annual Show, Automobile Club of Hartford, State Armory.
- Feb. 20-24.....Binghamton, N. Y., State Armory, Third Annual Show, Automobile Dealers' Association.

- Week Feb. 22.....Cincinnati, O., Annual Show, Cincinnati Automobile Dealers' Association.
- March 2-9.....Boston, Mass., Tenth Annual Show, Boston Automobile Dealers' Association, Inc.
- March 4-9.....Denver, Col., Auditorium, Annual Show.

### Meetings, Etc.

- Nov. 20-24.....Richmond, Va., First American Road Congress, under auspices of American Association for Highway Improvement.
- Nov. 22.....Road Users' Day, under direction of Touring Club of America.
- Jan. 18-20.....New York City, Annual Meeting of the Society of Automobile Engineers.

### Race Meets, Hill-Climbs, Etc.

- Oct. 27-Nov. 3....Chicago, Ill., Thousand-Mile Reliability Run, Chicago Motor Club.
- Nov. 2-4.....Philadelphia Reliability Run, Quaker City Motor Club.
- Nov. 3.....Newark, N. J., 125-mile Automobile Endurance Run, Newark Star.
- Nov. 3-4.....Columbia, S. C., Track Races, Automobile Club of Columbia.
- Nov. 4-6.....Los Angeles-Phoenix Road Race, Maricopa Auto Club.
- Nov. 9.....Phoenix, Ariz., Track Races, Maricopa Automobile Club.
- Nov. 9-10.....Chicago, Team Match, Amateurs vs. Trade Members to Waukesha and Return, Chicago Automobile Club.
- Nov. 9, 10, 12....San Antonio, Tex., Track Races, San Antonio Auto Club.
- Nov. 13.....Harrisburg, Pa., Economy Run, Motor Club of Harrisburg.
- Nov. 27.....Savannah, Ga., Vanderbilt Cup Race, Savannah Automobile Club.
- Nov. 30.....Los Angeles, Cal., Track Races, Motordrome.
- Nov. 30.....Savannah, Ga., Grand Prize Race, Savannah Automobile Club.
- Dec. 25-26.....Los Angeles, Cal., Track Races, Motordrome.

### Foreign

- Nov. 3-11.....London, Eng., Olympia Show.



# THE AUTOMOBILE

Vol. XXV

Thursday, November 2, 1911

No. 18

## THE CLASS JOURNAL COMPANY

H. M. SWETLAND, President

CONDE NAST, Vice-President and General Manager

E. M. COREY, Secretary and Treasurer

231-241 West 39th Street, New York City

Cable Address - - - - - Autoland, New York  
 Long Distance Telephone - - - - - 2046 Bryant, New York

### SUBSCRIPTION RATES

United States and Mexico - - - - - One Year, \$3.00  
 Other Countries in Postal Union, including Canada - - - - - One Year, 5.00  
 To Subscribers—Do not send money by ordinary mail. Remit by Draft,  
 Post-Office or Express Money Order, or Register your letter.

Entered at New York, N. Y., as second-class matter.

The Automobile is a consolidation of The Automobile (monthly) and the Motor  
 Review (weekly), May, 1902, Dealer and Repairman (monthly), October, 1903,  
 and the Automobile Magazine (monthly), July, 1907.

## The Long-Stroke Motor

TO-DAY everybody is talking the long-stroke motor, but as yet only a very few have definite ideas as to whether there are advantages in it, compared with the square motor of to-day, to warrant the immediate adoption of the long-stroke one. The condition of chaos at present is explained by the different views taken on the question by different factories and also by different engineers. One leading American engineer has been experimenting this Summer with a new long-stroke type and he has announced that he has found it to be less economical of gasoline than a square type and yet give no extra power to compensate for it. Another engineer states that he gets more power out of the long-stroke motor on hill-climbing work over a certain degree of grade, but that under a certain percentage of grade the square motor is superior. One maker, who is an enthusiastic racing man, asserts that he has obtained better speed results out of a long-stroke motor than he ever could dream of obtaining out of the square or nearly square size. So the story of the long-stroke motor goes. Not a single engineer has come anywhere near solving it. They are all, or at least a big percentage of them, trying to solve it, but are yet far from the goal. All of them are learning and education is what we need.

Glancing at the results obtained by not a few of the foreign makers it is interesting to see that the more they investigate the long-stroke problem the better results they are obtaining. One of the best-known motor builders in France—whose ideas have been more widely imitated in America than those of any other foreign builder—has reduced the bore and added to the stroke of every one of his different motor sizes for the coming season. By reducing the bore and adding to the stroke he has increased the horsepower from 6 to over 12, according to model. Not only has the power been increased but the consumption of gasoline has been reduced. This alone is a big factor with the European maker and it is bound to become a factor with many of the American makers. This is particularly the case

when it is accompanied by an increase in horsepower. Everybody is looking for an increase in motor efficiency, and if with it can be had a reduced fuel consumption a great victory has been won. The foreign maker has been experimenting with the long-stroke motor for many more years than the American maker, and naturally has solved the problem to a much greater extent. He started off his experiments with racing motors, but during the season just closed what he learned in racing has been applied in modified form to his touring results and the outcome is proving most satisfactory. The racing of a year ago proved that more power can be obtained from a relatively small-powered long-stroke motor than from a very large square type, when certain valve changes are carried out. The same is taking place to-day with touring cars.

Having discovered this in more or less certain terms, at least to suit himself, the foreign builder has for next year gone stronger than ever to long-stroke design. Of the new models that are being exhibited this week at the Olympia in London there is not a solitary one in which the bore is in excess of the stroke, and there is only one in which the bore measures exactly the same as the stroke. In all the others the stroke is much in excess of the bore. A few generalities will suffice to explain this: One of the oldest European builders, and a name which stands highest of all in the automobile engine field, has brought out a new 1912 model of motor with a bore of 70 millimeters and a stroke of 120 millimeters, which is a stroke-bore ratio of 1.71 to 1; in other words the stroke is nearly 75 per cent. greater than the bore. This maker is not a radical, rather has he been looked upon as one of the most conservative of the big builders, and it is a certainty that he has not brought out this new model without having tried it out in every detail. Generally a corps of engineers work on a new model before it is announced and it is never finally accepted until one or two of the directors have given it a thorough tryout; consequently when a new type of these proportions is announced its kinks are generally removed. The act of this maker alone is a big argument for the long-stroke motor. But the story of this one could be repeated with over fifty other concerns. All through it is the longer-stroke type. The proportions of stroke to bore rarely drop below 1.5 to 1; that is, a motor with the stroke over one-half as long again as the bore. Many of the makers have the proportion as high as 1.66 to 1 and a few have reached 1.81 to 1. One or two of the smaller builders have brought out 2 to 1 ratios.

Many arguments are to-day being urged against the long stroke, one being that it makes a longer cylinder casting necessary and so raises the center of gravity of the car. This is true, but it is also true that much can be done to reduce this weight, and it is along this line that much is being done to-day. With the long-stroke motor it would be almost out of the question to try to use valves in the head, and it would be impossible to have an overhead camshaft. As a result the long-stroke motor has started the study of the valve problem. The new location of the valves is but one of the divisions of this question. The shape of the cam has to be altered, the diameter of the valve is a point to be settled, and the manifold problem also presents itself. But if the long-stroke motor presents some troubles in connection with

valves it simplifies others. Owing to the longer cylinder castings it permits of a better grouping of the carbureter, the magneto, the water pump and, if necessary, a generator for the electric lighting system. The manifolds can be carried higher up and out of the way of these parts. The same applies to some of the water pipes.

Some have argued against the long-stroke motor on the ground of extra weight, reasoning that because the cylinder castings are longer and the stroke longer, the crankcase must be made deeper and the crankshaft throws longer, so that weight is added along the line. The net result is that makers have been cutting out unnecessary weight in their long-stroke types. The reciprocating parts have been lightened throughout. The tubular connecting rod has been introduced. It gives sufficient strength and is much lighter than the forged type in use at present. The piston has also been cut down in weight. Some makers use steel pistons and the rule of perforation is becoming very general. The crankshaft weight has also been reduced by drilling out the shaft from end to end and cutting down the weight in parts of the shaft where it has not been necessary. In this respect the long-stroke motor is doing much good in making it imperative that makers must improve it in order to make it practical. Necessity has always been the mother of invention, and in case of the long-stroke motor the truth of the adage is being proved once more.

Lubrication was at one time urged as an impossibility in the long-stroke type of motor. In the early days it was considered impossible to oil except with castor oil, and the offensive odor and high price were considered insurmountable obstacles. Well, the long-stroke has come

and it is being lubricated, and while castor oil is being used by many, others are demonstrating that it is not necessary and that many of our leading oil makers can produce a grade of oil that will meet all of the requirements. This is simply one more example of necessity compelling invention on the part of the oil people. They stand ready to fill the bill, and when new motor types demanding a special lubricant are brought out they come to the front and supply the lubricant. That maker would be a small quantity who would not build a certain type of motor, solely because he was afraid it could not be lubricated. There are often eccentric constructions, which are wrong from an engineering point of view and also from a manufacturer's viewpoint and which perhaps cannot be oiled, but the long-stroke motor does not come under this classification.

The American maker is wrestling with the long-stroke motor and is going to continue doing so. He will have to. Building a long-stroke motor is not simply adding an inch or so to the height of the cylinder casting, lengthening the connecting rods, making the crankshaft throws longer and deepening the crankcase. Building a long-stroke motor is an engineering problem from the ground up, and the man who will make a success must start out in a broad-minded way to settle the question. He must balance one part to suit the other and cannot pick some pieces out of a four-cylinder motor and put them into a long-stroke one. The conditions under which the two kinds operate are different, the problems in them are different, and each must be approached from its own viewpoint. In a word, the two are entirely different in the many problems that enter into them.

## Schimpf Succeeds Butler

WILLIAM SCHIMPF, president of the Long Island Club and a member of the A. A. A. Contest Board for the past year, has been appointed by President Robert P. Hooper to fill the vacancy caused by the death of the late Samuel M. Butler. The appointment followed a conference involving President Hooper, of the A. A. A., and President H. E. Coffin, of the Manufacturers' Contest Association, which co-operates with the owners' organization in the conduct of automobile competitions. Mr. Schimpf is the head of one of the largest automobile clubs in this country, and is naturally greatly interested in competitions, his service on the board having given him a complete understanding of the needs of the position to which he has been appointed.

## Last Rites for Samuel M. Butler

Samuel M. Butler's funeral was held at his late home in Brooklyn on Sunday in the presence of a considerable number of his close personal and business associates. Floral tributes were numerous and beautiful. The exercises were simple. Interment was at Greenwood.

Despite the fact that the funeral was private there were many men prominent in automobiling circles present, including all his associates in the A. A. A. and many high lights of the trade newspaper world.

There was a splendid array of floral exhibits which had come from personal friends, including handsome designs from the Automobile Club of America, the Manufacturers' Contest Association, the Chicago Motor Club and his associates at the National headquarters in New York City.

## Soft Pedal on Show News

LEAST the publication of show arrangements check retail business at this season, the Automobile Board of Trade and the National Association of Automobile Manufacturers have put down the soft pedal on announcements for the time being. Business is reported fairly good along the row but the tendency to slow up in anticipation of the shows is felt in some quarters.

As a matter of fact, the developments in the show situation during the week have not been important and simply represent normal progress in preparation for the two big exhibitions to be held in New York.

## Composition Proposed for Streator

Composition of the unsecured debts of the Streator Motor Car Company, together with those of Paul R. Chubbuck and John C. Barlow has been suggested by a committee of the creditors of the embarrassed company. The plan brought forward is to release the company from liability for its former debts and the acceptance on the part of the creditors of bonds issued by the People's Trust and Savings Bank as trustee for the debtors. A trust deed conveying to the bank the assets of the Barlow and Chubbuck is a condition precedent.

The bonds will be signed by Barlow and Chubbuck and will be issued to the creditors through the bank if the proposal is accepted. Except for some trivial claims, the bonds are conditioned to mature as follows: 10 per cent. in 1 year from Sept. 23, 15 per cent. in 2 years, 20 per cent. in 3 years, 25 per cent. in 4 years, and 30 per cent. in 5 years, together with interest on the unpaid balances at 6 per cent.



Case, No. 3, Hansen, driver, finished four days with a clean score



Daubner in the Halladay, No. 5, stopping to repair tires

## Many Clean Scores in Chicago Run

**L**OUISVILLE, KY., Oct. 29—The fifth annual reliability run of the Chicago Motor Club, which started from Chicago Friday morning with seventeen contestants and five official cars, has completed two legs of the 8-day tour that has been mapped out by the Chicago organization. Illinois, Indiana and part of Kentucky have been traversed and as yet nothing has been accomplished toward deciding the winners. Only one of the seventeen cars has been penalized and that only for trivial troubles brought about largely by the inexperience of the driver—an amateur who put in his big National roadster for the fun of it. Certainly sixteen cars clean after 404 miles of going is a most remarkable showing, a showing such as never before has been made in a Chicago reliability.

The tour got an auspicious start from Chicago Friday morning, with only one car scratched, that a Lion that was pulled out because the change of date did not suit the entrants. This left nine running in the touring car section and eight in the roadster division, striving for four prizes—the touring car cup, the Van Sicklen roadster trophy, the Chicago Motor Club team trophy and the fuel economy prize offered, as usual, by the Standard Oil Company.

The first day's run was from Chicago to Indianapolis over a route that differed from the conventional in that it followed a new trail that led past Hazelden farm, the home of George Ade,

the novelist, who had invited the motorists to make his place the noon control. It was 94 miles to this place and it was easily negotiated even though the contestants had to make a 5-mile detour just out of Crown Point because a new stone road that was included in the original route had not been opened to traffic. The stop at Ade's long will be remembered by the contestants. The novelist gave the motorists the run of the farm and the noonday meal was served by the Daughters of Ruth, who are raising a fund to build a church. The novelist also had a "life saving" station on the second floor which was greatly appreciated by the motorists after the cold drive. He also provided them with souvenir postal cards, already stamped. Of course each man wrote one and Ade agreed to mail them. This gave him an opportunity to crack a merry joke. In writing for the Indianapolis *Star* of the visit of the Chicagoans, Ade dryly added: "I have read all the souvenir postal cards left here to be mailed, and I find that the visitors were wildly enthusiastic about the dinner."

It was no trick at all to drive from Ade's to Indianapolis, although the distance was 130 miles, and everyone got in on time and with plenty to spare. The work of the technical committee was easy, for there only was one card to consider, that of Paul Strauss, driver of the National, who had drawn 3 points for carbureter adjustments at the start, undoubtedly caused by the chill weather. All others were clean and no one had any complaints to make.

In the evening the Chicagoans were the guests of the newly formed Hoosier Motor Club and the evening was devoted to speeches by men prominent in the motor world.

### Indianapolis to Louisville

The run from Indianapolis to Louisville yesterday only was 178.5 miles, but it proved an eye-opener to the Chicagoans, who had not realized that right at their doors is a touring territory that cannot be beaten anywhere in the country. Certainly the Berkshires can offer nothing better in the way of scenery and the roads through southern Indiana and that portion of Kentucky running into Louisville cannot be improved upon much. The Chicagoans struck the beautiful scenery about 20 miles from the noon control, Bedford. Just outside of Medora, 83 miles from Indianapolis, was encountered a most remarkable hill which would have been a serious proposition had it rained. It is about 1-2 mile in length and the average grade is about 16 per cent. It is a veritable corkscrew, with little short turns that wind not



Velie, No. 104, Stickney at the wheel, unpenalized at half-way point

abruptly but continuously to the top. There must be not fewer than ten turns on the way up—in fact, it is like climbing a chimney. The road bed itself is excellent and the road winds through a thick wood that but adds to the beauty of the climb.

Leaving Bedford at noon, the tourists found they had but just tapped the southern beauty vein. The magnificent roads continued and the tour had hardly left Bedford before there was encountered a most remarkable freak of nature—a hogsback road that ran for about a mile on the top of a sharp ridge between two beautiful valleys. One could look either way and drink in the scenery. On one side was a winding river and on the other heavy woods. The road itself took up the full width of the ridge and no driver dared take his eye off the highway to peek at the scenery lest he plunge into a chasm.

Hardly had they passed this beautiful stretch than the winding road brought them face to face with a hill that made Algonquin pale into insignificance, a 20 per cent. grade that rose abruptly from the valley road. Luckily it was straight and the road good, else there might have been trouble. No one, however, experienced any trouble getting up.

This fine road continued to within about 30 miles of Louisville. At one place it followed an interurban trolley, being first on one side and then on the other. Someone counted and declared afterwards that this trolley line was crossed no fewer than thirty times before the trail straightened out and swung into Louisville.

Reaching here yesterday afternoon, the tourists looked back over the day and marveled at the wonders. They declared themselves surprised at the fine roads of southern Indiana. It was surprising, too, because there were so few motor cars encountered on the road, while the inhabitants themselves did not seem to be overburdened with wealth. Yet there were found well-built roads, wide and rutless, with stone bridges at some places, and, best of all, these roads have every appearance of being maintained. The towns themselves seemed prosperous, but the day's journey failed to show any great motoring strength in this section. The people themselves seemed friendly to motoring and in each town the inhabitants gave the tourists the glad hand.

This trip of the Chicagoans seems destined to open the eyes of the western motoring world to the beauties that lie at their doors. It is hard to realize that within a day's journey of Chicago there is a territory that is so rich in good roads and fine scenery as this and it is predicted that in another year the itinerary that is being followed by the Chicago Motor Club will be the scenic tour of the middle west.

The run from Indianapolis here failed to disturb any of the perfect score section. Strauss in the National drew 27 more points—14 for changing spark plugs and 13 for being late. The Case bent part of its steering connection trying to follow the trail over a stretch of railroad ties, but this was whitewashed by the technical committee because the checker had failed to carry



Midland, one of the official cars, did excellent work on Medora hill

out the instructions of the referee. When the stretch over the tracks was reached the referee saw the confetti spread along it, but he realized this was asking too much of the cars and he found a detour through a back yard and ordered the confetti strewn that way. The old paper was not picked up and the leading cars took the railroad route, the Case meeting with its mishap in consequence. The referee held that the accident had been brought about by the failure of one of the officials to carry out orders and no penalty was imposed.

Resting up to-day, the Chicagoans this afternoon were the guests of the Louisville Automobile Club, which kept open house and devoted the entire afternoon to its guests.

From here the tour goes to Cincinnati to-morrow, Columbus Tuesday, Detroit Wednesday, Grand Rapids Thursday and home Friday.

#### Louisville to Cincinnati

CINCINNATI, O., Oct. 30—The contestants in the Chicago run finished a double century from Louisville this afternoon, and after the count was made to-night it was discovered that the remarkable record of the contest had been retained to a certain extent. Two drew black marks to-day, making three in all that have been demerited since the start of the run from Chicago last Friday. That fourteen cars could go 592 miles with perfect scores is a record seldom equaled in reliability contests. The two to lose their perfect scores to-day were No. 107 Grout in the roadster division and No. 9 Staver-Chicago, in the touring car class.

The Grout met with its mishap this morning. Coming down a hill 40 miles out of Louisville it skidded and before Halbert could

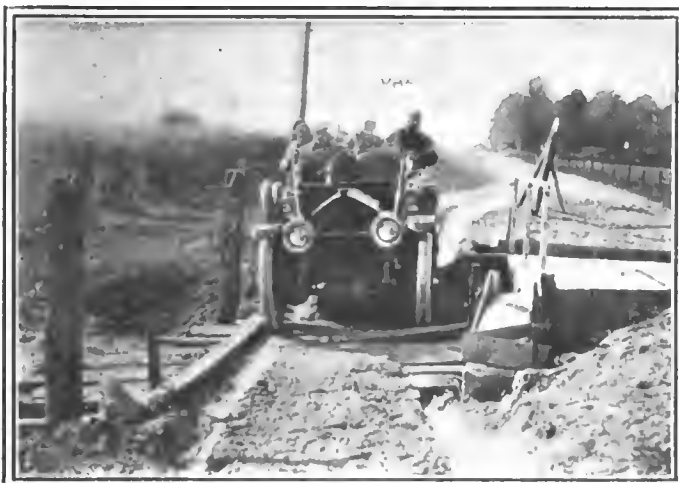

The National press car negotiating a tender bridge the first day



Some of the roads traversed the first day were miniature lakes

secure control of it it had run off a bridge, ripped off a rear tire and broken a spring. The occupants had a close call. Halbert patched up the broken spring, incurring 40 points thereby, to which was added 8 points for being late. The Grout will get more to-morrow morning, for it is the intention to replace the broken spring. Monckmeier's Staver was given 9 points, 7 of which were for adjusting a ball retainer and the other two for being late.

But one of the other perfect scores is threatened, No. 101, Moline, which is being driven by J. Boone; going through Shelbyville, at 12 miles an hour, a negro driving a rig turned in front of Boone, who found it impossible to avoid a bump, the result being a bent fender.

The trip to-day again led through the picturesque portion of Kentucky and over good roads, too. It was sprinkling when the tour pulled out of Louisville for a 100-mile run, but the rain was a gentle one and did not harm anyone. The roads being of stone construction, it was easy to keep going and no one worried over the weather. At Frankfort, the capital of Kentucky, the tourists were duly impressed with the high bluffs and the winding roads, but they were lost in admiration at Shakertown, when they swung down a big mountain into the Kentucky River valley, the deep gorges and the rocky formations being of a grandeur to which the Chicagoans were not accustomed. Lexington, the noon control, was reached after a trip of 116 miles and in the afternoon the tour was resumed over roads that were as winding as a corkscrew. One can get an idea of the twists by learning that the railroad was crossed thirty-seven times during the afternoon between Lexington and Covington, Ky.

The Chicagoans also got their first toll-gate experience this afternoon, being forced to pay tribute five different times. They found, too, that the roads at this end of the day's run are not so good as in the morning.

This evening the visitors were given a royal reception by the Cincinnati Automobile Club, which put on a big stag and smoker.

From Cincinnati to Columbus

COLUMBUS, O., Oct. 31—To-day's run of the Chicago Motor Club's Reliability, the fourth of the tour, was prolific of incidents that happily resulted in no one being hurt, but which decimated the perfect score field by three and left eleven surviving for the honors of this classic. The Halladay and the Oldsmobile Autocrat in the touring car division, and No. 104, Velie, in the roadster class, were demerited, while Halbert, in the Grout, had to replace the spring he broke yesterday.

The Halladay incurred 19 points, 3 of which were for cleaning the gasoline line and 16 for work on a fender iron that broke. The Oldsmobile started out with a broken gasoline line, small in itself but which grew like a rolling snowball until to-night there are charged against the Autocrat 455 points, while still more

await it when the technical examination is made Saturday. To start out with, the break in the line compelled Winters to take on gasoline three times, for which he was fined 9 points. Then at the noon control at Washington Court House, he was obliged to lay up and take off the body to mend the leak. That cost 208 points. This done, the Oldsmobile started for Cincinnati, but a mile out of town in trying to pass a horse-drawn vehicle it skidded, hit the team and just escaped plunging down a 20-foot bank. It required nearly three hours to get out of this fix, the farmers being called on to help with horses. This made the Oldsmobile late to-night and the time penalty was 238 points.

The penalization of the Velie was slight, only 1 point. Davies fixing the muffler cut-out rod, which had become disconnected. The Grout got 340 points to-day, 246 being used up in putting in the new spring, two for a clutch adjustment and 92 for being late at the noon control. The car was on time to-night.

Another victim to-day was the Abbott-Detroit 44, driven by Robbins, which broke a leaf in the front spring while yet in the limits of Cincinnati. Robbins did not have to touch it, however, and it looks as if he would be able to go through the tour with it, which would not cost him his perfect road score. The penalization of the Velie and the Halladay leaves the Moline the only make clean for the team trophy, for which it has a double chance, for this cup is decided by the two best aggregate scores. The Staver, the fourth contender, was penalized yesterday, when Monckmeier caught it.

The run to-day was 178 miles from Cincinnati to Columbus, with the noon control at Washington Court House, 98 miles. The morning route ran through Dayton and the afternoon touched Chillicothe. When the tourists left this morning the skies were cloudy and the roads muddy following last night's rains, which made the going necessarily slow.

The run to-morrow will be a hard one, Detroit being the destination. The roads between Toledo and Detroit are reported bad, and it may be necessary to make a detour to get past some of the impossible stretches. The table of penalties up to date follows:

No.	Car	Driver	1st day	2nd day	3rd day	4th day	Total
1	Moline	N. Van Dervoort	0	0	0	0	0
2	Moline	Salisbury	0	0	0	0	0
3	Case	Hansen	0	0	0	0	0
5	Halladay	Daubner	0	0	0	19	19
6	Halladay	Davies	0	0	0	0	0
7	Oldsmobile	Winters	0	0	0	455	455
8	Abbott-Detroit	Robbins	0	0	0	0	0
9	Staver-Chicago	Monckmeier	0	0	2	0	2
10	Staver-Chicago	Knudsen	0	0	0	0	0
<b>Roadsters</b>							
100	Moline	Wicke	0	0	0	0	0
101	Moline	Boone	0	0	0	0	0
102	Oakland	Bauer	0	0	0	0	0
103	Velie	Gibbons	0	0	0	0	0
104	Velie	Stickney	0	0	0	1	1
105	Bergdoll	Monsen	0	0	0	0	0
106	National	Strauss	3	27	0	0	30
107	Grout	Halbert	0	0	48	340	388



A quartet of entrants in the recent electric vehicle parade in Denver, driven by Mr. N. O. Hunsicker, Mrs. L. W. N. Waters, Mrs. H. B. Simmons and Miss Blanche Edison





Group of members of the Society of Automobile Engineers en route to England on the Mauretania

## S. A. E. Delegates Sail for England

**T**HEY'RE off for Olympia! At 9 o'clock Wednesday morning a party consisting of fifty-five persons, representing the Society of Automobile Engineers, sailed for England on the steamship Mauretania on the first official visit of that organization to foreign shores.

The S. A. E. was invited to hold a joint convention with the Incorporated Institution of Automobile Engineers of England and the present trip is the outcome.

The following list is a roster of the party: B. B. Bachman, Ardmore, Pa.; Mr. and Mrs. Walter C. Baker, Cleveland, Ohio; Mr. and Mrs. J. S. Bretz, New York; Mr. and Mrs. Albert Champion, Flint, Mich.; Mr. and Mrs. H. D. Church, Detroit, Mich.; Mrs. D. H. Church, Cambridge, Mass.; Coker F. Clarkson, New York; Mr. and Mrs. Howard E. Coffin, Detroit, Mich.; John A. Crowley, New York; Arthur B. Cumner, Philadelphia, Pa.; E. A. DeWaters, Flint, Mich.; H. F. Donaldson, New York; F. S. Duesenberg, Des Moines, Iowa; B. G. Ellis, Boston, Mass.; John W. Foster, Amesbury, Mass.; C. H. Foster, Cleveland, Ohio; H. Jay Hayes, Detroit, Mich.; Robert T. Hendrickson, Fremont, Ohio; J. B. Hull, Cleveland, Ohio; William Kelly, Detroit, Mich.; George W. Kerr, Chicopee Falls, Mass.; Hugh Kerr-Thomas, Buffalo, N. Y.; Charles B. King, Detroit, Mich.; Mr. and Mrs. W. P. King, Cleveland, Ohio; Mr. and Mrs. Robert McA. Lloyd, Long Island City, N. Y.; D. G. McDiarmid, Chicago, Ill.; Mr. and Mrs. Alden L. McMurtry, New York; Carl J. Metzger, Ottawa, Ill.; William E. Metzger, Detroit, Mich.; Mr. and Mrs. Charles J. Moore, Detroit, Mich.; Bert Morley, Detroit, Mich.; C. S. Mott, Flint, Mich.; Ralph H. Rosenberg, Columbus, Ohio; A. J. Slade, New York; C. O. Snyder, Chillicothe, Ohio; Paul L. Snutsel, New York; H. C. Stutz, Indianapolis, Ind.; H. T. Thomas, Lansing, Mich.; T. R. Thomas, Racine, Wis.; G. R. Wadsworth, Cleveland, Ohio; W. G. Wall, Indianapolis, Ind.; Mr. and Mrs. G. A. Wahlgreen, Denver, Col.; Mr. and Mrs. Henry C. Wilson, New York; John G. Wood, Indianapolis, Ind.; Mr. and Mrs. S. G. Wingquist, Gothenburg, Sweden.

The following members will join the party in Europe: A. Ludlow Clayden, London; C. E. Davis, Muncie, Ind.; Marcel

DeJarney, London; Charles L. Lawrence, Paris; Fritz Loeffler, Walhof, Mannheim, Germany; Louis C. Marburg, New York; A. J. Moulton, New York; A. J. Myers, Paris; Rene M. Petard, Paris; Adolph Rosner, Bridgeport, Conn.; Alfred J. White, Coventry, England; David R. Wilson, Cleveland, Ohio; Arthur Ziltener, Wessen, St. Gallen, Switzerland.

### Olympia Show Offers Promising Outlook

LONDON, Oct. 21.—In less than a fortnight the doors of the big Olympia building in the West End will be opened to disclose the tenth International Exhibition of Automobiles and Accessories promoted by the all-powerful trade organization, the Society of Motor Manufacturers and Traders. On Nov. 3 the show will be opened without ceremony, and it will run on till Nov. 10.

Never before has there been such a crowded assembly; some 310 exhibitors share the space, and fifty more, unable to find an unoccupied corner, are housed in neighboring showrooms.

It is rather a notable fact that nearly half of the number of American car agents are outside the show; this does not indicate that they were last with their applications, but rather that they do not care to sign the bond and guarantee clauses in respect of other exhibitions and trade maintenance generally.

To prevent the crush which has always occurred at previous exhibitions, the admission price is doubled on two days and doubled again on Society Day, Nov. 7. Another advantage from the visitor's point of view is the new rule forbidding the stand attendants to smoke while on duty. A further prohibition relates to mechanically operated working models; these usually attract such crowds that neighboring stand-holders find their business interfered with. Models there will be in plenty, but small boys will provide the necessary horsepower.

As regards the general outlook, interest is likely to center on the new small four-cylinder cars (admittedly a competitor of the American light car, but hardly a worthy foeman), on the medium-powered six-cylinder vehicles, and on the covered body exhibits. As far as the accessory section is concerned, electric lighting dynamo equipments are the special feature this year.

# French Clubs Resume Race Control

ON October 18 the committee on sports of the Automobile Club de France convened with René de Knyff in the chair to decide whether the club should organize any automobile contests in 1912. The comments of the French automobile press with regard to the probable decisions of the committee—and no doubt intended to influence these decisions—throw light on the situation and a reflex light on the export interests of American manufacturers.

In an article in *L'Auto* on the day of the meeting, Charles Faroux, the editor of *La Vie Automobile*, wrote as follows:

"It is infinitely probable that the organization of one or perhaps even two contests will be decided. Public opinion has made itself plain in this direction. The purchaser wants one or two races. Better acquaintance with the progress accomplished by our rivals has sufficed to show that races are desirable, and a glance at our export statistics for the past two years demonstrates their necessity. From the purely utilitarian viewpoint a trial for light vehicles commends itself on lines similar to those inaugurated with so much success by *L'Auto* in the Boulogne races. As a matter of spectacular sport and with a view to striking the susceptibilities of the philistine masses, a race for large vehicles seems equally necessary.

"The regulations for the light vehicle race will be determined in due time and should be considered with great care. As regards the rules for the race for heavy cars, the report that absolute liberty will be adopted seems to be confirmed. It is well known what the writer thinks of this policy after having thought a great deal on the subject lately: It represents the worst possible conclusion whether looked upon from a technical or a national viewpoint. All the races which have been run for several years in France or abroad have shown with eloquent unanimity that the builders never cared to perfect any points in the design excepting those affected by the regulations. When there was a weight limit the metallurgical end of the builder's art made progress, and that only. Gains in motor or transmission efficiency date from the appearance of regulations bearing upon the bore or the fuel economy. Recently, at Boulogne, where the writer had neglected the question of weights a trifle, the vehicles were at once found to be far too heavy. They were ten years behind in this respect, at the same time that they exhibited great progress in motors and transmissions. At aviation contests this experience is repeated.

"Many say: 'Let all race who will, and we shall soon see who is the best.' But this is a layman's argument. It represents the negation of all method. They say it represents a formula which the public can understand. True, but mechanical progress is not concerned with the public; it is accomplished apart from the public choice. In fact, has the public ever adopted a demonstrated improvement at once, whether the question was of magnetos or of ball bearings?

"Then there is another side to the matter. On a basis of absolute liberty all that is required for winning is time and money, and these requirements can be met abroad as well as in France. To win under studied rules, on the other hand, requires a highly organized experimental and engineering department, superior service in 'tuning up' and a substantial experience in racing and technical matters; and these are all things in which we excel. This is no time for fanciful decisions. Whether one likes it or not, a race bears certain relations to the industrial development."

As anticipated in the article quoted above, the decision taken by the Sport Committee of the Automobile Club de France at the meeting referred to was in favor of resuming race control

and the resolutions adopted provided for one free-for-all race to be known as the Grand Prix of the A. C. F., and in addition for a race designated as Coupe du Journal *L'Auto* for cars with a cylinder volume limited to 3 litres (183.066 cubic inches), and in other respects similar to the Grand Prix de Boulogne race which was so successfully arranged by *L'Auto* during the past year.

It is provided that the two races shall both extend over two successive days and that a distance of about 1,000 kilometers shall be covered by each of the contestants each day, making the total distance about 2,000 kilometers; change of drivers will be permitted.

Neither of the two events is to take place before June 23, 1912, but otherwise the dates are still to be decided. Both are to be run at the same time, however, and it is considered probable that the Dieppe course will be selected as the battle ground. The races will both be international, and the Sport Committee has provided a prize of 20,000 francs for the winner of the Grand Prix, this prize to be awarded to the builder of the fastest car, irrespective of the nationality of the constructor or the classification of the vehicle.

*L'Auto* mentions as certain competitors for the Grand Prix the Lorraine-Dietrich, the Darracq, the Cottin-Desgouttes, the Rolland-Pilain, the Fiat, the Mercedes, the Benz and four American cars, the Marmon, the Lozier, the Stoddard-Dayton and the National. The information with regard to the intentions of the manufacturers of these cars is said to be authorized. As possible participants are mentioned the Clement-Bayard, Mors, Opel (German) Itala, S. P. A. and Austrian Daimler.

For the Coupe du Journal *L'Auto*, the following are referred to as most likely to take part: Delage, Lion-Peugeot, Sizaire-Naudin, Gregoire, Hispano-Suiza, Côte (two-cycle engine), Koechlin (two-cycle engine), Sunbeam, Vauxhall, Calthorpe, Arvol-Johnston, Argyll, Excelsior, Fif, Mathis, Laurin-Klement and Puch.

## Fords in French Glidden

By conference between a number of French manufacturers and the directors of the journal *L'Auto* a new set of regulations has been adopted for the Tour de France, to take place March 1 to 16, 1912. The event will be a test of endurance and regularity for stock cars of the light vehicle and the voiturette classes. As light vehicle any car may be entered which is catalogued for 1912 at a price for the chassis, without tires, not exceeding 8,000 francs, and as voiturette any car whose 1912 catalogue price is not higher than 4,000 francs, including the cost of body as well as tires.

The entry lists were opened Friday, October 21, at the offices of *L'Auto*, in Paris, and will remain open until January 31, 1912, midnight. Entries must be accompanied by the entry fee which is scheduled as follows: For one light vehicle 500 francs, for two light vehicles of the same make 900 francs, for three light vehicles of the same make 1,200 francs; for one voiturette 250 francs, for two voiturettes, 450 francs and for three voiturettes 600 francs. Every participant must produce before being allowed to start, an insurance policy proving that the life of the driver and the risk to third parties are covered in the sum of 100,000 francs in case of accident, and a duplicate of this policy must be deposited in advance at the office of *L'Auto*.

Among the very first entries for this contest were three Ford cars (American), one Delage car and three Barre cars, all in the light vehicle class.

# Late Trade and General News

**PITTSBURGH, PA., Oct. 31**—Decision of the suit entered by the Republic Rubber Company, of Youngstown, O., against Morgan and Wright, with regard to alleged infringement of patents granted to the plaintiff concern for staggard tread tires, is expected next week. The patent in question was issued to T. J. Mell, of the Republic company, in 1907, and it is alleged that the Morgan and Wright patent was not filed until January, 1910.

The suit is in the United States Circuit Court and was heard by Judge Hazel. The complaint asks for an injunction against the defendant company prohibiting it from manufacturing its knobby tread tires and for damages for infringement. Several tire companies not affected by the suit have been manufacturing non-skid tires and it is stated that after the completion of the matter in hand the Republic company contemplates more litigation.

Christy & Christy, of Pittsburgh, represented the complainants in this action and Ernest Hopkinson, Edward W. Vaill and Antonio Knauth, of New York, appeared for Morgan and Wright.

## Date Set for Indianapolis Race

**INDIANAPOLIS, IND., Oct. 31**—At a meeting of the Speedway management to-day it was decided that the second annual 500-mile International Sweepstakes race will be held on next Memorial Day, May 30, at the Speedway. The prizes for the event will amount to \$50,000, to be divided into twelve awards as follows:

First, \$20,000; second, \$10,000; third, \$5,000; fourth, \$3,000; fifth, \$2,500; sixth, \$2,000; seventh, \$1,500; eighth, \$1,400; ninth, \$1,300; tenth, \$1,200; eleventh, \$1,100; twelfth, \$1,000.

The race will be for cars with 600 cubic inches piston displacement or less and a minimum weight of 2,000 pounds, making it a class E event. The speed requirement will be 75 miles an hour for one full lap of the 2 1-2-mile track. The field of starters will be limited to the thirty fastest cars to be selected in competitive trial if more than thirty entries are registered at the time of the race. In case of rain the A. A. A. has given permission for the race to be run on the following Saturday.

## Oklahoma to Vote on Bonds

**OKLAHOMA CITY, OKLA., Oct. 30**—A bond issue of \$1,250,000 for good roads in Oklahoma county will be voted on at a special election which has been called by the county commissioners. This election will be held November 23 and is called in response to a petition presented to the commissioners.

The petition contained 13,000 names and was the longest petition ever submitted in the history of Oklahoma county for any purpose. Oklahoma City is the county seat and pays more taxes than the rest of the county outside of the corporate limits but the petition was signed by town people with as much promptness as it was by farmers.

## T. C. A. Party Starts from Atlanta

**ATLANTA, GA., Oct. 30**—Starting from this city to-day the path-finding party of the Touring Club of America commenced its journey to Richmond at 8 o'clock. The trip will cover Greensboro, Ga., Augusta, Columbia, S. C., Camden, Cheraw, Pinehurst, N. C., Raleigh, Henderson, Emporia, Va., and Richmond

as night and noon stops, a distance of 695.3 miles. The party will arrive in Richmond November 3.

Those who compose the party are: W. J. Dabney, Richmond. Henry MacNair, New York; H. B. Varner, Lexington, N. C.; Lee A. Folger, Richmond; F. H. Elliott, New York; D. D. Armstrong, Atlanta, and W. D. Gordon, Richmond. All are prominent in the movement for good roads from a national aspect. Through the various States to be traversed the party will be escorted by highway commissioners and others who are making a close study of road construction and maintenance. A Chalmers six-cylinder car is being used as pilot in charge of Mr. MacNair, editor of the *Blue Book*.

## Ready for Dash Across Desert

**LOS ANGELES, Oct. 30**—Sixteen tuned to the minute and desert-equipped motor cars will start on a 550-mile battle with the mountains and sand at 10.45 Saturday night. The start will be from the center of the Los Angeles business district and for 2 days and 1 night these machines and their crews will be covering the distance across the great American desert between Los Angeles and Phoenix in as fast time as can be made by a motor-propelled vehicle. Following is a list of the entrants:

Car.	Piston Dis.	Driver.
1—Maxwell	229	Clarenee Smith
2—Pope-Hartford	299.4	W. D. Tremaine
3—Franklin	301.5	Ralph Hamlin
4—Stoddard-Dayton	550	E. Roger Stearns
5—Cadillac	286	W. W. Bramlette
6—E. M. F.	226.2	W. La Casse
7—Flanders	154.8	Geo. Sou'ea
8—Cole	286	John Jenkins
9—Mereer	286	H. Hanshue
10—Case	236	W. F. Brong
11—National	448	Harvey Herrick
12—Pueik	318	L. Nikrert
13—Fiat	618	Teddy Tetzlaff
14—Midland	318	F. Siefert
15—Lexington	280.6	C. Bigelow
16—Buick	318	J. Ferguson

## Tire Makers Busy with Orders

**AKRON, O., Oct. 30**—The state of the automobile industry and the magnitude of plans being made for next year's business by automobile manufacturers, is reflected in the activity now apparent among Akron tire factories, all of which report that they are much busier now than is usual at this time of year. Akron tire makers are prepared for unprecedented production this winter, based on orders already booked or assured, due to the unusual campaigns mapped out by the manufacturers of medium priced cars.

The steadiness of the crude rubber market at a satisfactorily low rate has helped to ease conditions in the tire business. Since the breaking of the Brazilian and British corner in South American rubber, there have been few marked fluctuations in crude rubber quotations, and local manufacturers predict that for several years at least there can be no such soaring of rubber prices as were recorded a year and two years ago.

## Six New Members of the A. B. of T.

The following new members have been elected to the Automobile Board of Trade: Warren Motor Car Company; James Cunningham Son and Company; Garford Company; Reliance Motor Truck Company; Rapid Motor Vehicle Company and the Marquette Motor Company. The latter organization is practically a consolidation of the Welch-Detroit and the Rainier.



**C**HICAGO, ILL.—Many dealers and branch house managers attended a convention held at the plant of the Velie Motor Vehicle Company, Moline, Ill., October 20 and 21. Meetings were held at the assembly hall and talks on various subjects were given by men of the different departments: Chief Engineer C. B. Rose, General Manager Major L. M. Fuller, Sales Manager George H. Floyd and his assistant, Charles P. Hatter. A banquet was given on Friday evening in the Marble Hall at the Manufacturers' Hotel. Major L. M. Fuller acted as toastmaster. Immediately afterward the visitors were escorted in pleasure and commercial cars to the American Theatre, at Davenport, Ia.

**AKRON, O.**—The Jones Auto Company, of 53-55 South High street, has taken the agency for the 1912 Hudson.

**WASHINGTON, D. C.**—Earl & Allen, who are agents for the Hupp-Yeats electric, have secured the R. C. H. car.

**WASHINGTON, D. C.**—The Overland-Washington Motor Company has been appointed agent for the Garford in this city and the surrounding territory.

**WASHINGTON, D. C.**—M. T. Pollock, agent for the Oldsmobile, is making extensive improvements in his salesroom at 1018 Connecticut avenue, N. W.

**BOSTON, MASS.**—George H. Bammann, well known in Boston motor circles, has accepted a position with the Bi-Motor Equipment Company as a salesman.

**WASHINGTON, D. C.**—The Waverly Elec-

tric agency has been placed with the Luttrell Company, Dupont Circle and Connecticut avenue. This company also handles the Packard.

**PHILADELPHIA.**—A local branch of the Polack Tyre Company, manufacturer of solid rubber tires for commercial vehicles, has been established at No. 408 North Randolph street, with M. Smolens as manager.

**PHILADELPHIA.**—An eastern distributing agency for the Cutting car, of Jackson, Mich., has been established at No. 1431 Spring Garden street. Benjamin H. Kirkbride is manager for Pennsylvania, New Jersey and Delaware.

**INDIANAPOLIS, IND.**—The Rapid Motor Transit Company, of this city, began its motor bus service on November 1 with seven gasoline motor busses built by the White Company, of Cleveland, O. The cars are lighted and heated by electricity.

**INDIANAPOLIS, IND.**—R. L. Bartol has resigned as manager of the Ford sales branch in this city and has been succeeded by Dayton E. Keith, formerly with the Ford sales branch in Chicago. Mr. Bartol will conduct the Ford agency in Anderson, Ind.

**SYRACUSE, N. Y.**—The H. H. Franklin Manufacturing Company is now taking on mechanics to meet needs occasioned by increased production. Machine departments are working evenings, and several hundred skilled machinists will be put on during the coming weeks, it is reported.

**TWO RIVERS, WIS.**—Officials of one of the big aluminum manufacturing companies here deny reports that prices of

raw and finished aluminum are slated for a decided drop. Although competition is growing stronger, the demand is increasing more than proportionately and no decline is looked for.

**PHILADELPHIA.**—Edwin H. Lewis, well known in local automobile circles and a prominent member of the Quaker City Motor Club, has become associated with the factory sales department of the Louis J. Bergdoll Motor Company, acting as traveling representative of the company.

**COLUMBUS, O.**—According to State registrar of automobiles Shearer Ohio is second among the States of the Union in automobile registration. In the report of licenses issued by the various States up to October 1, New York leads with over 80,000, Ohio is second with 45,421, and Pennsylvania is third with 43,074.

**MILWAUKEE, WIS.**—The Secretary of State of Wisconsin has announced that applications for 1912 registrations and licenses will not be received before December 15, instead of December 1, as previously stated. Annual registration went into force on September 1, 1911, in Wisconsin, and all cars will have to be registered by January 1.

**BEVERLY, MASS.**—The makers of the Cameron car at Beverly are arranging to enlarge their plant upon the receipt of more capital and offers have been made to them by another concern to consolidate. The company has just received word from abroad that in the closing race meet at Brooklands, Eng., the 70 miles an hour handicap was won by one of their 20-horse-

power cars from a field of 15 starters. It created much surprise, for the Cameron was not looked upon as having any chance to capture the event.

**NEW YORK CITY**—In the recent automobile exhibition at Berlin 82 manufacturers of automobiles exhibited. Of these 71, or 86.7 per cent., exhibited cars equipped with Bosch magnetos.

**BALTIMORE, MD.**—The Lambert Automobile Company is now located in its spacious new quarters at Maryland and Mount Royal avenues. The firm handles the Maxwell, National and Hudson cars.

**PITTSBURG, PA.**—The Pittsburg branch of the Franklin Automobile Company signed up two sub-dealers in this territory during the week: The Coraopolis Garage Company, of Coraopolis, Pa., and S. F. Carpenter, of Carbondale, Pa.

**AKRON, O.**—The B. F. Goodrich Company is opening three new Southern tire depots—at Nashville, Tenn., in charge of M. D. McKenzie; at Charleston, N. C., in charge of A. J. Kelcy, and at Birmingham, Ala., in charge of L. F. Joliat.

**TOLEDO, O.**—The Rambler Sales Company has accepted the agency for the Detroit Electric in Toledo territory. This car was formerly handled by the Toledo Auto & Garage Company, which will now devote its entire time and attention to the housing of cars.

**SYRACUSE, N. Y.**—A. D. McLachlan has severed his connection with the Royal Tourist Motor Car Company, of Cleveland, O., and accepted the position of general sales manager for the Sanford-Herbert Company of this city, who manufacture a light delivery wagon.

**TOLEDO, O.**—The Gamble Motor Car

Company, of Toledo, has taken over the agency of the Ohio Electric. An extended demand for this car is reported, several sales being closed during the past week with twenty-five deals in sight, which will be closed within the next few weeks.

**TOLEDO, O.**—Another car was this week added to the already long list handled on Motor Row, at Toledo, O. It is the Metz four-cylinder runabout, which sells at \$495. The Northern Ohio Motor Car Company will handle the car in Toledo territory. A number of selling agencies will be established in Northern Ohio.

**BOSTON, MASS.**—Manager Frank J. Tyler, of the United States Motors Company's Boston branch, has decided to have the Stoddard-Dayton branch moved into the building on Massachusetts avenue at the corner of Newbury street, where the Maxwell, Brush, Sampson and Columbia are handled, so that all will be together.

**SYRACUSE, N. Y.**—Automobile exhibits exercised commanding interest at the first annual exhibition, under the auspices of the United Commercial Travelers, of the Industrial Exposition and Pure Food Show at the Syracuse Armory this week. Local agents declared after the show that it had brought them a round total of \$60,000.

**AKRON, O.**—The factory of the Good-year Tire & Rubber Company has shut down for purposes of inventory and rearrangement to meet the demands of increasing business. During the shut-down a transfer was accomplished from steam to electric power for driving machinery, a fine electric power plant having been installed.

**BOSTON, MASS.**—On October 31 the Boston Y. M. C. A. officially opened the finest and best equipped automobile school in America, if not in the world. It is a fire-

proof building, three stories high, sixty feet wide and nearly two hundred feet long. It contains lecture rooms, laboratories, machine shop, garage, and every feature for the handling of the automobile with the exception of the manufacture of new cars.

**NEW YORK CITY.**—The Abbott-Detroit Motor Company, of New York, reports a big Fall agency business. Within the last two weeks they have signed up contracts, ranging from 50 to 250 cars each, with thirty agents, among whom are the following: Co-Operative Motor Car Company, Buffalo, N. Y.; Central Auto Sales Company, Utica, N. Y.; Abbott-Detroit Sales Company, Rochester and Syracuse, N. Y.; Ryder Motor Car Company, Poughkeepsie, N. Y.; F. W. Smith, New Haven, Conn.; Binghamton Ford Sales Company, Binghamton, N. Y.; William Stevenson Garage Company, Morristown, N. J.

**INDIANAPOLIS, IND.**—The fall automobile show held recently by the Premier Sales Company of this city at its sales rooms was an unqualified success, and will be made an annual event in the future. Hundreds of visitors attended the show daily and much interest was manifested. Many persons pronounced the exhibit the most striking they had ever seen. The idea of the desert scene, which occupied half the space, was taken from the Ocean-to-Ocean Tour of twelve Premier cars last summer, when the forty tourists camped out in the desert while en route from the Atlantic to the Pacific Coast. Sand, cactus and sage brush were used, surrounding the tents of the campers and two of their cars, the pilot and prairie schooner. The rest of the space was taken up with Series M models.



Fall exhibit of the Premier Indianapolis branch. On the left is reproduced some of the desert conditions encountered on the Ocean-to-Ocean tour





Bird's-eye view of the principal plant of the Lozier Motor Company at Detroit, Mich., employing eleven hundred men

DETROIT, MICH.—W. Edward Wilson, of the Wilson Body Company, died suddenly at his home here, from heart disease. He was 38 years old and was one of the most popular men in local motor circles.

DETROIT, MICH.—The Continental Motor Manufacturing Company has begun work on an addition to its Muskegon plant. The extra room is greatly needed. The plant is now running full capacity, night and day.

DES MOINES, IA.—The Brown-Corley-Ellis Company, local agent for the Marmion, Paige-Detroit and Kelley trucks, has started the erection of a two-story building at Fourth and Grand avenues which is to be completed in sixty days.

DES MOINES, IA.—George Means, a well-known Des Moines automobile dealer, was married this week to Mrs. Genevieve Tucker-Evans, of this city. A motor trip to Kansas City was the honeymoon for the newly married auto man and his bride.

DETROIT, MICH.—Work is being rushed on the new addition to the Hudson Motor Car Company's plant in an effort to have it ready for occupancy by Dec. 15. The new building is 530 feet long, 60 feet wide and two stories high. It will increase the company's floor space to 236,411 square feet.

DETROIT, MICH.—Walter E. Blaine, a draughtsman for the Packard Motor Car Company, has been declared the winner of the Flanders 20 offered by the Board of Commerce for suggesting the most suitable name for the water carnival to be held next Summer. It will be known as the Cadillacqua.

DETROIT, MICH.—The Chalmers technical convention, which was continued last week with 28 technical men from the Middle West and South in attendance, is proving so popular that the company has decided to add a fourth week to the convention program. Accordingly the sessions will not end until the week of Nov. 6.

OMAHA, NEB.—A two-story garage and sales room is being erected at Fortieth and Farnam streets for the Electric Garage

Company. This is the first garage to be built in the residence district, being in one of the most fashionable districts in the city. Practically all of the garages are between Sixteenth and Twenty-fourth streets, on Farnam.

DETROIT, MICH.—William B. Wreford, formerly well known in local motor car circles, has been promoted to the position of assistant secretary of the Detroit Board of Commerce. Mr. Wreford left the automobile business several months ago to become municipal secretary of the board and in that capacity he has rendered most efficient service.

DES MOINES, IA.—The United Motors Des Moines Company, which is the State agency for the United States Motors Company, will move this week to the quarters formerly occupied by the state agency for the Buick Company. The Buick State agency has been closed. George W. Jones is the manager of the United Motors Des Moines Company.

DES MOINES, IA.—The Iowa Auto & Supply Company, the pioneer firm in this field, has announced the erection of a fine two-story building to house the concern. The new building will be on the site of the present quarters at Fourth and Grand avenues and will be the finest repository in the State. The Iowa Auto & Supply Company was recently merged with the Keystone Auto and Supply Company.

PERU, IND.—The Great Western Automobile Company of this place has brought out a new automobile body with detachable fore doors which, when removed, leave the car as a finished open touring car with no disfiguring posts nor mouldings. The compartment under the rear seat can be reached through a door at the rear of the body as well as by lifting the seat cushion. This obviates the annoyance of disturbing the occupants of the seat.

DETROIT, MICH.—The Hupp Motor Car Company has appointed Charles D. Hastings as its new general manager and the directors are satisfied that they have made

a very happy selection. Mr. Hastings is given a large share of the credit for the successful development of the sales organization and his suggestions have resulted in many economies in the manufacturing end of the business. For several years before he became identified with the Hupp Company Mr. Hastings was with the Olds Motor Works.

INDIANAPOLIS, IND.—Mr. Carter, president of the Henderson Motor Sales Company, accompanied by Charles P. Henderson, general manager of the same company, Mrs. Carter, Mrs. Henderson and Miss Henderson has returned to this city after a six weeks' trip through Minneapolis, Winnipeg, Vancouver, Seattle, Portland, San Francisco and Los Angeles. Their object was pleasure, but Mr. Henderson turned part of his trip into business. Stops were made at scenic points on the Canadian-Pacific.

AKRON, O.—The first seven trucks owned by the Chicago Fire Department came equipped with Diamond wire mesh base motor truck tires and the service given by them has been such that the same equipment was specified on the nine police patrols and four fire police patrols recently purchased. On preliminary tests these must make 45 miles an hour, while an average of 35 miles an hour is maintained in making runs. The average mileage given by the tires to date has been over 15,000 miles on fire trucks and over 10,000 miles on police trucks.

DETROIT, MICH.—Frank Briscoe, who has been at the head of the Detroit division of the United States Motor Company since the corporation was organized, has gone to New York to take full charge of the company's engineering work. This necessitated his resignation as president of the Briscoe Manufacturing Company and the Brush Runabout Company and as treasurer of the Alden-Sampson Company. Hereafter the plants will be operated as units. Mr. Briscoe left for New York last Tuesday. His office will be at 3 West 61st street.

LOS ANGELES, CAL.—Manager Charles Cotton, of the Los Angeles Motor Car Company, Southern California, representative of the Locomobile, announced last week the removal of the Locomobile headquarters from Rice and Hill streets to spacious quarters at Eleventh and Flower streets.

DETROIT, MICH.—As a part of the improvements being made at the Ford plant a complete new heating and ventilating system is being installed by the Coon-De-Visser Company. It will supply the present plant as well as the large addition that is being built, washing, heating and circulating about 750,000 cubic feet of air per minute.

PORTLAND, ORE.—Rambling through the State of Oregon in an automobile was the way in which Mr. and Mrs. J. L. S. Snead, of the Krit Motor Sales Company, of this city, spent their honeymoon. They packed a camping outfit and provisions on their little two-passenger car and spent nearly two weeks out of doors. In this time the state was traversed from end to end and the trip cost less than \$60.

CLAREMONT, CAL.—The local speed limit has been raised from twelve to fifteen and twenty miles an hour. This was received by the Southern California motorists with joy, as the college town has been avoided of late because of the drastic measures said to have been taken against autoists who exceeded the speed limit. The raising of the limit is due to the efforts of the officials of the Automobile Club of Southern California who have been working for months with the Claremont officials.

SAN FRANCISCO, CAL.—The Olds Motor Works has incorporated a branch house here under the title of the Oldsmobile Company of California. W. J. Mead, vice-president and general manager of the Olds Motor Works, has been named as president of the California branch. John H. Hagal, one of the best known automobile men on the Pacific Coast, is vice-president; R. N. Mosher, treasurer; F. E. Stewart,

secretary and assistant treasurer, and D. L. Whitford, director. All five constitute the officers and board of directors of the new company.

NEW YORK CITY.—The Mitchell Motor Company of New York opens to-day its extensive new salesrooms at the corner of Broadway and 61st street. The space occupied by the company in its new location is much in excess of the area covered by the old sales quarters. At the same time the new service department, at 519 West 55th street, is placed at the disposal of Mitchell

owners. This is a six-story building and will be entirely devoted to service purposes, specifically so far as the Mitchell products are concerned. The total area of all the floors of the building is little short of 30,000 sq. ft.

EL PASO, TEXAS.—The Southwest Auto Company, 407 and 408 Caples Building, has embarked in business there with a capitalization of \$100,000 as general sales agents for automobile manufacturers. The original incorporators are L. S. Davis, Geo. I. Waddey, T. A. Frey and L. A. Brashear.



## Automobile Incorporations

### AUTOMOBILES AND PARTS

BUFFALO, N. Y.—Whyland-Nelson Motor Car Co.; capital, \$10,000; to manufacture engines and automobiles. Incorporators: Frank A. Shoemaker, Frank W. Whyland, Joel W. Nelson.

CINCINNATI, OHIO—Muhle Motor Co.; capital, \$20,000; to do a general automobile business. Incorporators: Henry M. N. Muhle, John C. Miller, Ida Muble, Mary Smith, Elizabeth Muhle.

CINCINNATI, OHIO—Spring Hub Automobile Wheel Co.; capital, \$10,000; to manufacture wheels for motor cars. Incorporators: James G. Blackburn, Ino H. Kruse, James T. Earle, Harry H. Weihe, Harry W. Plum, Robert Freisen, Edgar Woolley.

COLUMBIA, S. C.—Etheredge Motor Co.; capital, \$10,000; to sell automobiles. Incorporators: C. L. Etheredge, Robert L. Mitchell, E. J. Etheredge.

DECATUR, IND.—Decatur Motor Car Co. has increased capital from \$250,000 to \$350,000.

GAAND RAPIDS, MICH.—Michigan Auto Joint Co.; capital, \$10,000; to manufacture automobile parts, especially universal joints. Incorporators: C. E. Perkins, F. Carter.

LANSING, MICH.—Little Motor Car Co.; capital, \$1,200,000; to manufacture automobiles. Incorporators: S. W. H. Little, C. M. Begole, W. S. Ballenger, W. C. Durant.

LOUISVILLE, KY.—Clark Motor Car Co.; manufacturer of automobiles, increased capital from \$30,000 to \$60,000.

NEW YORK CITY—Bayles Sales Co.; capital, \$10,000; to make and sell automobiles. Incorporators: Harry T. Bayles, Halsey K. Smith, Ansel P. Anderson.

NEW YORK CITY—International Motor Service Association—to manufacture automobiles. Incorporators: W. H. Brearley, W. W. Friend, I. A. Monsees.

NORFOLK, VA.—Mitchell Agency; capital, \$10,000; to sell automobiles. Incorporators: H. T. Richardson, S. H. Butt, V. Butt.

OCALA, FLA.—Florida Automobile & Sales Co.; capital, \$25,000; to sell automobiles. Incorporator: B. R. Hinson.

PORTSMOUTH, VA.—Mitchell Agency; capital, \$10,000; to sell automobiles. Incorporators: H. T. Richardson, S. H. Butt, V. Butt.

PORTSMOUTH, OHIO—Portsmouth Automobile & Machine Co.; capital, \$10,000; to make and sell automobiles. Incorporators: Lincoln Pool and others.

ST. CHARLES, MO.—Boenker Motor Plow Mfg. Co.; capital, \$24,000; to make motor plows. Incorporators: H. H. Boenker, Louis Ringe, L. G. Wilbrand.

ST. PAUL, OHIO—Brockshire & Robinson Co.; capital, \$20,000; to manufacture automobiles. Incorporators: F. M. Brockshire, W. T. Robinson, John Schooler, H. L. Pentz, H. C. Brockshire.

WHITE PLAINS, N. Y.—William Marshall, Inc.; capital, \$20,000; to make automobiles. Incorporators: William Marshall, Marguerite Young, John Hamilton.

### AUTOMOBILE GARAGES AND ACCESSORIES

CINCINNATI, OHIO—Ohio Top Co.; capital, \$25,000; to manufacture and sell tops for automobiles. Incorporators: Robert F. Kroger, William Bossemeyer, Bion Place, Amanda Bossemeyer, Louise H. Bossemeyer.

CLEVELAND, OHIO—Burke Valve Co.; capital, \$50,000; to manufacture tire valves.

FIVEPOINTS, ALA.—Highland Garage; capital increased from \$5,000 to \$25,000; to do a general garage business. Incorporators: L. E. Whitehead, F. E. Whitehead.

FREMONT, OHIO—Northern Ohio Punctureless Tire Co.; capital, \$3,000; to make a patented tire. Incorporators: Frank E. Nieset, Lewis Nieset, John J. Nieset, L. P. Nieset, C. N. Brown.

HAGERSTOWN, MD.—Antictam Garage Co.; capital, \$5,000; to do a general garage business.

NEW YORK CITY—La France Motor Car Co., changed name to La France Garage Co.

NEW YORK CITY—Auto Sectional Leather Tire Co.; capital, \$50,000. Incorporators: Herman L. Biener, Isidore Scherer, Moses Scherer.

NEW YORK CITY—United Automobile Owners' Protective Association; capital, \$25,000; to inspect automobiles and conduct a chauffeurs' agency. Incorporators: H. E. Tibid, H. A. Trebing, A. J. Davenport.

PHILADELPHIA, PA.—Eareckson, Hofacker & Fleming; to conduct a general garage business.



Bird's-eye view of the Plattsburg, N. Y., plant of the Lozier Motor Company, employing six hundred men

# OF INTEREST *to the* INDUSTRY



White 1½-ton army escort wagon, built for the Government

**CLEVELAND, O.**—The White Company has just delivered to the Government of the United States an army escort wagon which shows a most interesting development of the motor vehicle for freight transportation in connection with military work. The wagon was built according to Government specifications, and if found successful will in all probability be used in considerable numbers by the military service. The regular 1½-ton White chassis has been used in the building of this wagon.

**FREMONT, O.**—Harry Bowlus, formerly of the Gramm Motor Car Company, of Lima, O., has accepted the position of superintendent of the factory of the Lauth-Juergens Motor Car Company of this place.

**COLUMBUS, O.**—The Eagle Motor Car Company of this city, which has been manufacturing the Eagle Roadster, has changed its name to the Union Sales Company and the name of its car to the Union 25.

**MILWAUKEE, Wis.**—The Beaver Manufacturing Company, which is owned and controlled by the Filer & Stowell Company, is now operating under full schedule its new modern plant covering more than 120,000 feet of floor space.

**DAYTON, O.**—N. H. Anderson, chief engineer of the Speedwell Motor Car Company, Dayton, O., has tendered his resignation, to take effect Dec. 1, 1911, and intends to give his entire time to his new process of rolling the teeth in steel gear blanks while hot.

**OSHKOSH, Wis.**—H. C. Doman has disposed of his interest in the H. C. Doman Company, manufacturing motors and engines, and will retire. The new owners of his interest are Philip H. Sawyer and Edgar P. Sawyer, well-known manufacturers of Oshkosh.

**HARTFORD, Wis.**—The new factory building of the Kissel Motor Car Company, in which most of the assembling will be done, will be ready for occupancy about Dec. 1. The factory is working to full capacity and the additional room is much needed to enable the concern to keep up to its 1912 schedule.

**NEWCASTLE, IND.**—A reorganization of the Whitesides Commercial Car Company, which is moving from Franklin, Ind., to Newcastle, Ind., has taken place, the new company being incorporated with an authorized capitalization of \$31,250. The directors are L. C. Boyd, F. N. Whitesides, O. C. Saffell, T. B. Milliken and W. G. Hillock.

**COLUMBUS, O.**—Attorney-General Hogan, of Ohio, has rendered an opinion recently which is of interest to firms and corporations acting as agents for motor cars in the Buckeye State. It is held that when a partnership changes its name it is not entitled to the use of the old registration and number plates, but must register anew and secure different number plates.

**NEWARK, N. Y.**—A peremptory sale of the entire Mora Automobile plant, including sixty cars, machinery and building plant will be held Tuesday, Nov. 14, and

Wednesday, Nov. 15, 1911. Bidders will be offered an opportunity of purchasing single cars. Arrangements will be made with the purchasers of the patterns to supply the owners of the Mora cars with any part desired.

**DETROIT, MICH.**—The differences and litigation that have existed for several years between the Timken Companies and Lindsay & Harmon, of Indianapolis, regarding the Lindsay patents on rear axle constructions, under which the Timken Companies have been operating, have been amicably settled and adjusted, and the Timken-Detroit Axle Company retains complete shop rights under these patents.

**RICHMOND, VA.**—Ground has been broken for the automobile factory which the Kline Motor Car Company is to erect in Richmond. The site is on the boulevard near the Fair Grounds, and the contract calls for a complete structure by Feb. 1, 1912. The plant will cost about \$300,000 and will give employment to about 1,000 men when in full operation. It is said that orders have already been received for cars valued at \$800,000 though no deliveries can be made until next year.

**MILWAUKEE, Wis.**—The Lavigne Gear Company, of Detroit, Mich., has decided to move to Wisconsin and the equipment and machinery are now being installed in buildings of the Wisconsin Engine Company at Corliss, Wis., 25 miles south of Milwaukee. The company has been incorporated under the laws of Wisconsin with an authorized capitalization of \$100,000 by Charles E. Albright, George Uihlein and Norman L. Baker, of Milwaukee. The concern manufactures gears for motor vehicles and as a specialty makes a gear which is a substitute for the worm gear.

**LAFAYETTE, IND.**—The Esterline Company, Lafayette, Ind., manufacturer of the Berdon electric lighting system for motor cars, announces the appointment of the following sales representatives: New York City, Mr. Mortimer L. Newman, 114 Liberty street; Atlanta, Ga., the Automobile Specialties Company, Mr. L. O. Surlles, manager, 222-224 Peachtree street; Denver, Col., Western Engineering & Specialties Company, 1732 Glenarm street; San Francisco, Cal., the Symonds-Berle-Kirkpatrick Company; Los Angeles, Cal., the Symonds-Berle-Kirkpatrick Company; Cleveland, O., Chas. F. Saenger & Co., 210 Electric Building; Boston, Mass., the Standard Engineering Company, 53 State street; New Haven, Conn., the Standard Engineering Company, 81½ Chapel street; Waterbury, Conn., the Standard Engineering Company, 16 East Main street.

# PATENTS GONE TO ISSUE

**D**IFFERENTIAL GEARING—Axles are rotated by gears in mesh with idlers on stud in differential housing.

1. The patent relates to a balancing gear, Fig. 1, consisting of a housing member, a primary driving gear and a casing member, the driving member being detachably secured to the housing and casing members. The housing member carries a stud, the length of which is equal to the housing diameter, and idlers are carried on the stud. The axle sections entering the gear casing and abutting the stud carry secondary driving gears, which have motion imparted to them by the idlers on the stud. The ends of the stud are held to the housing member by means of cap screws.

No. 1,006,847—To James G. Heaslet, Detroit, Mich., assignor of one-half to Walter E. Flanders, Pontiac, Mich. Granted October 24, 1911; filed July 27, 1910.

**HYDROCARBON POWER PLANT**—A system consisting of a number of combustion chambers and a working gas turbine.

3. The plant shown in Fig. 2 is a combination of a shaft with a system of internal combustion motors symmetrically surrounding the shaft on which is mounted, besides the motor cylinders, a working turbine. Between motor system and turbine is mounted a collecting chamber connected by passages to the motor plant. Means are provided to prevent the escape of heat from the chamber and nozzles are in the chamber directing the flow of gases from there to the turbine. A compressor turbine has its running wheel mounted on the shaft and a suction pipe leading to it. A delivery pipe connects compressor and motor system and it contains a cooling device. An annular compression chamber communicating with the delivery pipe and with the working cylinders is provided.

No. 1,006,907—To Alfred Buechi, Winterthur, Switzerland. Granted October 24, 1911; filed October 30, 1906.

**SPEED-CHANGING MECHANISM**—A system of regulating the gears serving for speed changing in an automobile.

5. Fig. 3 illustrated the combination, with the operating members of a speed-changing gear, of a gate-plate having one transverse slot and a plurality of longitudinal slots connected with the transverse slot mentioned, a plurality of super-imposed sliding plates movable parallel to the gate-plate and having apertures whose rear walls in the rearmost position of the plates register with the rear wall of the transverse slot of the gate-plate. Means are provided for guiding the sliding plates. A lever pivotally mounted to move in the slots of the gate-plate extends permanently through the apertures of the sliding plates, projections in these apertures corresponding relatively in position with the longitudinal slots in the gate-plate. Means are provided to connect the sliding plates with the operating members of the change-speed gear. A pedal is connected to the above-mentioned lever which has a projection. An independently pivoted cam-lever is adapted to engage the projection and to the cam lever is connected a pedal. A clutch and a brake rod are connected to the cam lever.

No. 1,006,893—To Arthur Henry Adams, London, and Marcus Charles Inman Hunter, Bedford, England, assignors to Adams Manufacturing Company, Ltd., London, England. Granted October 24, 1911; filed July 15, 1910.

**TENDER FOR TRACTION ENGINES**—Attachment for agricultural and similar machines for carrying fuel.

3. The tender comprises a body carrying a water tank and vertically hanging bearing sleeves. To each sleeve a wheel is pivotally connected, and between the sleeves a fuel rack is seated on the body and held in place by the sleeves.

No. 1,006,764—To Charles F. Maloney, Wheelock, N. D. Granted October 24, 1911; filed June 20, 1910.

**CARBIDE INDICATOR**—An indicator showing the quantity by weight of the carbide contained in the holder of an acetylene generator.

1. The patent is of an acetylene generator with a carbide holder having a tapering lower portion, around which loosely extends an annular plate supported by springs which are mounted in stationary members. Means actuated by the movement of the carbide holder are movable along a scale with weight graduations, indicating the weight of carbide in the holder.

No. 1,006,826—to Harry C. Buschmann, assignor to Jenne Acetylene Gas Machine Company, Indianapolis, Ind. Granted October 24, 1911; filed March 23, 1911.

**AUTOMATIC CONTROLLER**—Circuit controller for electric motors.

2. The patent covers, in a governor, the combination with a rotating shaft, of a pair of pivoted weights surrounding the shaft and having their greatest weights at their ends, and a longitudinally movable member provided with a pair of teeth at the sides of the shaft and midway between the weights which engage the teeth.

No. 1,006,802—to Simon Sparrow, assignor to Wagner Electric Manufacturing Company, St. Louis, Mo. Granted October 24, 1911; filed May 27, 1909.

**VALVE CAGE**—A type providing a tight fit for oscillating valves.

2. The patent relates to a cylinder adapted to receive a valve cage fitting tightly in the cylinder, and having ports separated by a bridge and a groove extending longitudinally from end to end of the cage and formed in the exterior surface of the bridge where the same makes contact with the cylinder bore.

No. 1,006,748—to Thomas Hall, assignor to Ridgway Dynamo and Engine Company, Ridgway, Pa. Granted October 24, 1911; filed February 11, 1911.

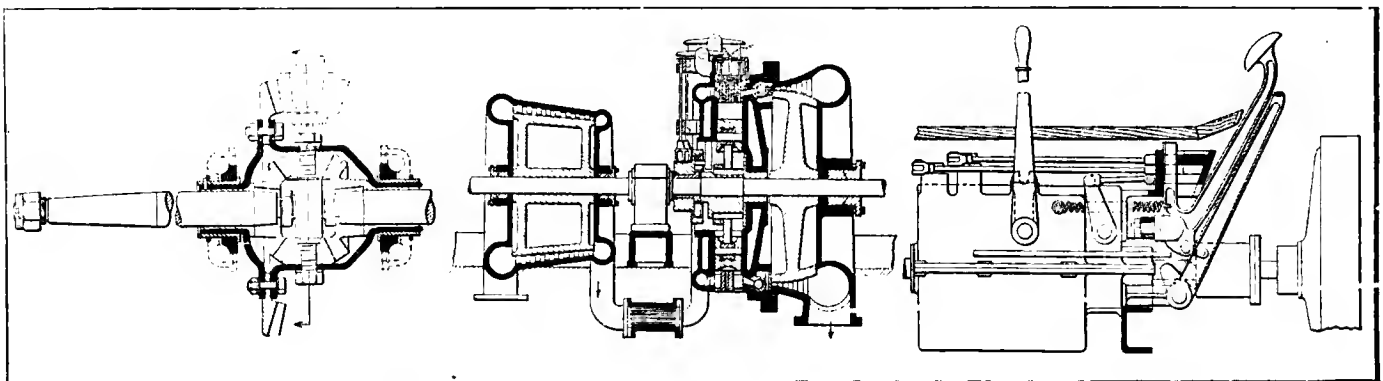

Fig. 1—Heaslet Flanders differential. Fig. 2—Buechi hydrocarbon motor plant. Fig. 3—Adams-Hunter speed-change mechanism

# Newest Ideas Among the Accessories

## Disco Self-Starter

**T**HE Disco, illustrated in Figs. 1 to 5, is made by the Ignition Starter Company, of Detroit, Mich. Its principle of operation is the injection of compressed acetylene into the engine cylinders and starting on the spark by means of this highly combustible fuel. The entire installation may be understood by referring to Fig. 1. When the Disco self-starter is installed the priming cups in the motor cylinders are replaced by so-called engine valves, Fig. 2. These valves consist of a lengthened priming cup and cock, and a connection is provided on the stem, through which acetylene may be led into the valve and cylinder. The acetylene is taken from the gas tank, flowing through a gas pipe to the distributor on the dashboard, whence it is distributed to the four engine valves. Turning the handle of the distributor, Fig. 3, permits the acetylene to pass through the distributor valve contained in this part of the system (Fig. 5).

The Disco principle is said to operate on any engine which stops or balances in a normal position, i. e., in one where a spark occurs in one cylinder, if the battery circuit is closed. It is necessary, of course, that the spark be strong enough to explode the mixture, in other words, that the ignition system be in good order.

Since the same acetylene tank supplies the gas to the starter and to the headlights and lamps, provision must be made to operate these two systems independently. This is done by using a two-way gas-tank connection, Fig. 4, by which half of the gas is directed to the lighting and the other half, if necessary, to the starting system. The two-way connection is so threaded as to be capable of replacing the standard connection on the acetylene tank.

It must be understood that in conducting the gas to the distributor and engine valves rubber tubing or some other piping except copper must be used. Although



Fig. 6—Lambert remountable rim which is controlled by a single bolt

very little acetylene is consumed through the Disco system—it is said that it starts an engine 3,000 times on the contents of one tank—the influence of the gas would in time change the copper gaspipes to acetylene-copper on the inside. This is a very dangerous material to handle, as the slightest concussion might bring about an explosion.

The fact that the acetylene tank and the ordinary ignition system are used in the Disco starting system goes to make it fairly foolproof, since everybody is nowadays familiar with the caution necessary in handling these two accessories of the automobile.

## Lambert Demountable Rim

The Lambert rim, which is illustrated in Fig. 6, is of the quick-demountable class. The side of wheel seen in Fig. 6 is the outside one, on which all the operations are done, and it is very simple in appearance, showing but one ratchet R and pawl, and an adjustment nut A for the purpose indicated. To take the rim off the wheel, the ratchet is turned by a special wrench

having a handle of the rotary drill type. About fourteen revolutions of the nut release the bolt integral with it from its seat, and as soon as this is done the tire rim and tire are forced off their seat on the felloe rim. This is caused by the peculiar shape of the latter, which converges toward the center line of the chassis. If the tire rim and tire are put in place the action of the bolt and the nut on the wheel felloe bring felloe and tire rim into tight relation, overcoming thereby the tendency of the wedges on the tire rim, which also tend to throw felloe rim and tire rim out of engagement. The adjustment nut A is very seldom used, as it serves only to take up wear.

After the tire rim has been removed from the wheel a slight shock produced by springing it on the ground permits of taking the rim out of the tire shoe. The rim is made in two steel sections, hinged at one end and engaging in a positive-lock manner on the other. The slight shock imparted to the tire disengages the locking portions and the hinged rim sections are easily pulled away from the tire and fitted to a new tire or the old shoe after a new tube has been placed into it. Hereafter the rim and new tire are bolted onto the wheel again. The bolt, which is integral with the ratchet, is the only loose part of the Lambert demountable rim. The pawl holds the ratchet in whatever position it is brought into by means of the wrench, but if the wrench is slipped over the nut attached to the bolt the pawl is pressed out of engagement with the ratchet, so that the latter may be rotated without difficulty. The handle of the wrench is of such size as to give considerable leverage and consequent ease of operation in screwing the rim on or off.

The Lambert rim is the product of the American Rim Company, of 250 West 54th street, New York City.

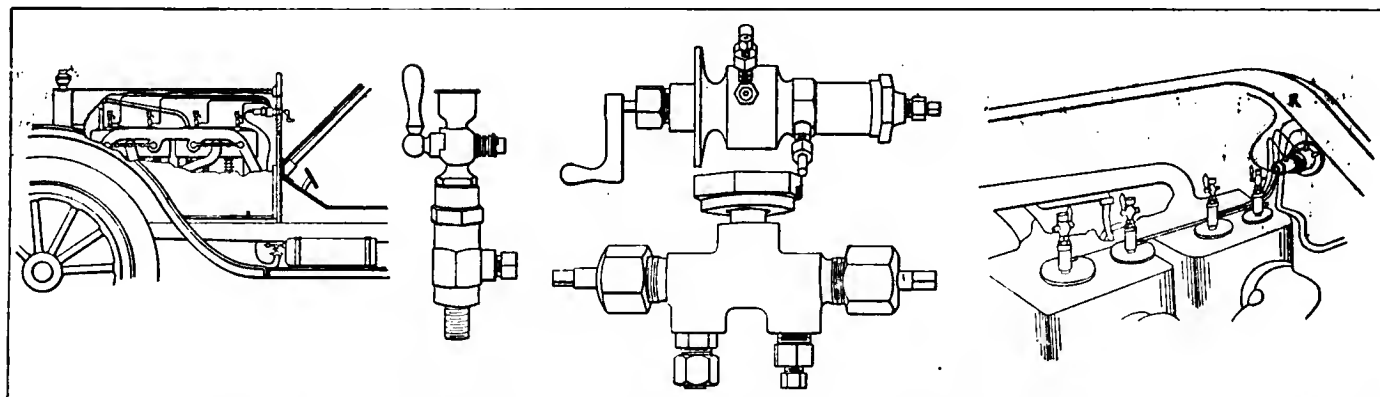
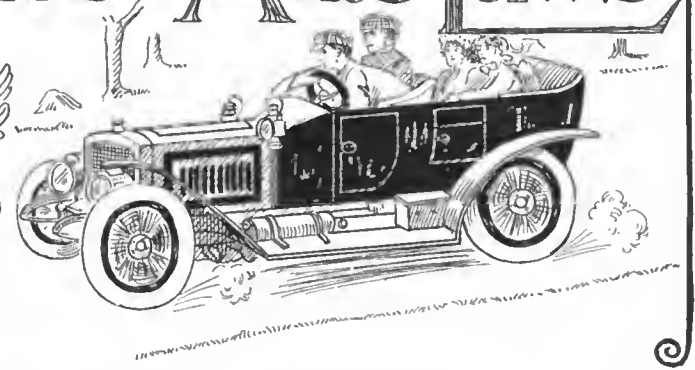
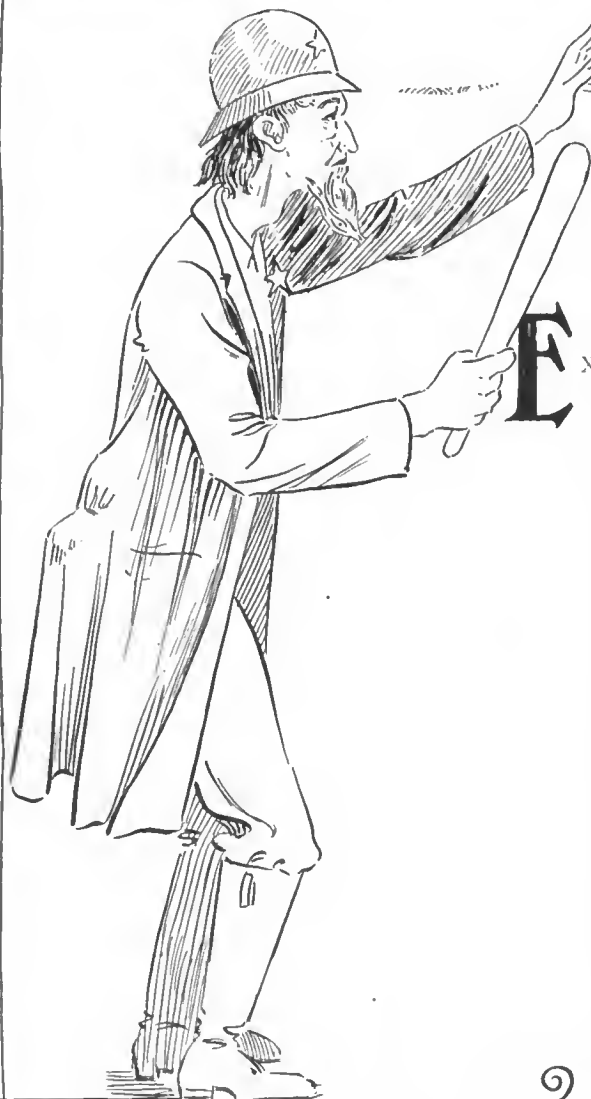

Fig. 1—View of Disco system. Fig. 2—Engine valve. Fig. 3—Distributor. Fig. 4—Two-way gas-tank connection. Fig. 5—Gas lead to engine valves



# THE AUTOMOBILE

## Inconsistencies in Auto Laws



EXISTING laws covering the operation of automobiles in the various states of the country have, by reason of numerous inconsistencies, proved trying to motorists in numberless instances. Not only is there a lack of uniformity in the laws of widely separated states, but even where they are contiguous there is often the widest divergence in the text and construction of the laws.

Nobody has questioned the police power of any of the states to regulate the speed and to lay down rules for automobiles and all other kinds of traffic. Neither has a voice been raised against the taxation of automobiles as personal property, precisely the same as horse-drawn vehicles or pipe organs or mining stock. No one has heard any protest against any law that has for its object the protection of the public from reckless driving or that tends to insure competence in paid drivers. But when it comes to subjecting interstate traffic of automobiles to the action of thirty-nine different sets of automobile traffic laws, patience ceases to be a virtue. Almost all these laws differ radically one from the other, and it would take something more than a Philadelphia lawyer to understand them all. Even then his understanding might differ from that of Si Perkins, constable of Prunty's Corners, or that of Squire Squidgins, J. P., who might be called upon to sit on his case.

In fact the automobile laws of almost every state in the Union have been construed and declared by the courts of the various states diametrically opposite at the same time.

Thus the legal situation is highly mixed and there is no possible way for a man to make absolutely sure of no interference by the authorities. For instance, in New York State

the statute says that 30 miles an hour continued for one-quarter mile is presumptive evidence of reckless driving. And yet nobody in New York City is sure that he can drive his car at all without coming in contact with the law.

Another instance recently noted in Virginia was the case of the Glidden tourists who were arrested at Harrisonburg for driving at 10 miles an hour when the State law says that 20 miles an hour is not illegal.

There are thirty-eight states that have special automobile laws, and the District of Columbia also rejoices in a set. There is no national law on the subject, and the preponderance of legal opinion seems to be that there can be no such unless Congress wishes to consider the taxing and regulating of one variety of interstate traffic without touching any of the rest. As this is prohibited by the constitution, the chances for a national law seem unflattering.

As an instance: If a horse-drawn truck, loaded with merchandise, traveled from New York to Washington, no question

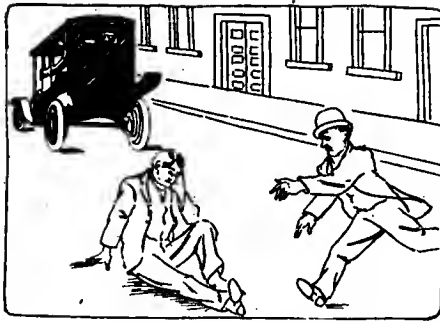

Felony in New York to escape after accident

the automobile coming from another state, but the national government could not do so, according to the opinion of well-versed legal lights.

Therefore, the remedy for the jumble into which the legal aspect has been mixed seems to lie in a common understanding among the states. Already steps have been taken that look to such an ultimate result.

The present status of the law in the thirty-eight states and District of Columbia as it applies to automobile operation is treated. Dividing the general aspect into eight phases or heads, a careful digest of the laws shows the situation to be unsatisfactory. The heads considered are these: Registration and fees; license to operate and fees; the law as to non-residents; equipment required; regulation of chauffeurs; speed provisions; penalties and the legal status of local ordinances.

#### Regarding Registration and Fees Therefor

With reference to registration and fees connected with that section of the laws there is a wide divergence of text and construction. In Alabama registration is required on October 1, when numbers are assigned and certificates issued. The fee is from \$7.50 to \$20, depending on horsepower. Manufacturers and dealers are required to register, the fee being \$100 in their cases, with an additional tax on the horsepower of all cars belonging to them. This is \$1 per horsepower under 20 horsepower and 50 cents per horsepower over that number. Registration number must be carried at the rear and only one set may be displayed.

In Arkansas yearly registration is required December 31; two sets of number plates must be shown, front and rear, and a metal seal issued by the Secretary of State must be carried. General registration is commanded upon the parts of manufacturers and dealers. The fee charged is \$5 per car.

In California the license plate must be shown in the rear, while on the front lamps the numbers must be displayed. Fee, \$2 a car.

Connecticut also requires annual registration; one set of numbers and fees based upon 50 cents a horsepower. Commercials must pay \$5 for cars of 1000 pounds' capacity or less, and \$2 for each additional 1000 pounds. The law also makes a charge of \$1 for each motor tested by manufacturers on the public highways.

Delaware makes it obligatory to show number plates in front and behind. Registration fee, \$5 a car.

In the District of Columbia the number must be shown behind and \$2 is charged for each identification tag.

Florida's law is similar.

In Illinois number plates must be shown front and

would be raised as to its rights to use the roads without paying any national or State license. If a gasoline motor were substituted for the horses there would be no more reason for taxing it than the horse-drawn wagon. The states might assume the right to regulate

rear, and the fees range from \$4 a car of less than 25 horsepower to \$10 for one of more than 50 horsepower. General registration is required for manufacturers and dealers, fee \$15.

Indiana only charges \$1 for registration.

In Iowa the fees range from \$8 for a car less than 20 horsepower to any additional amount reckoned at 40 cents a horsepower. After four years' payment on a car the fees are cut in half.

Kansas, Montana and South Carolina have made no legislative provision for registration, and consequently charge no fees for that particular thing.

Kentucky charges fees from \$10 to \$20, depending on horsepower, and requires numbers to be shown front and rear. Maine's law makes the fees from \$5 to \$15 for passenger automobiles and \$10 for trucks.

In Maryland the fees are from \$12 to \$24; in Massachusetts, \$5 to \$25; Michigan, \$3, and if the license is taken out after August 1 it is \$1.50.

In Minnesota registration is commanded every three years; fees, \$1.50.

Missouri law says that number plates may only be shown in the rear. Fees range from \$2 to \$12. The Nebraska motorist must pay \$2 a year. In Nebraska the fees run from \$10 to \$40; dealers are taxed \$40.

In New York annual registration February 1. Fees range from \$5 to \$25, and after four years' payment they are cut in half. Trucks and deliveries cost \$5 a year to register. From August 1 to February 1 the fee is half the statutory amount for one year.

New Jersey fees for registration are from \$3 to \$10, and in North Carolina \$5, with renewal privilege at \$1. North Dakota, \$3; Ohio, \$5; Oregon, from \$3 to \$10; Pennsylvania, \$5 to \$15. The Pennsylvania law provides that manufacturers and dealers'

cars shall only be operated by duly qualified and licensed drivers.

In Rhode Island the fee is from \$5 to \$25, with \$2 each for commercial cars and \$50 for manufacturers and dealers.

South Dakota charges \$1 for registration; Tennessee, \$2; Texas, 50 cents; Utah, \$2.

Vermont charges \$1 a horsepower and reduces the rate 25 per cent. a year for the second and third registrations. Virginia fees range from \$5 to \$20, with a dealers' fee of \$50.

Washington exacts \$2 for registration; West Virginia and Wisconsin the same amount.

It will be found that in a general way the regulations as far as registration are concerned are pretty much alike except as to the amount of the fees charged. Annual registration is definitely commanded in twenty-five of the states and is understood in six others. Three states do not require it, in addition, of course, to the other eight, which have no automobile laws at all.

Fees range from 50 cents in Texas to \$40 in several of the states where a maximum charge is imposed for registration.

The main idea involved in this section of the law is to get a complete record of ownership so as to insure identification. Several states reduce the fee after the original entry.

#### As to Licensing Automobile Drivers

The second phase of the automobile laws is that which provides licensing to operate. In Alabama only chauffeurs come under the rule, save that no person under 16 years' of age may run a car unless accompanied by an adult.

In Arkansas, California, Florida, Illinois, Michigan, Missouri,

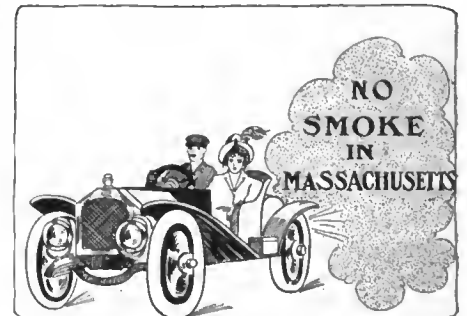

The old Bay State laws punish smoking

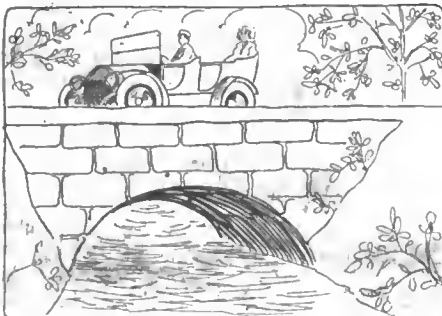

North Carolina—5 miles an hour over bridges

Ohio, Pennsylvania, Utah and West Virginia there are no licenses required to operate cars except in the case of paid chauffeurs.

Indiana, Iowa, Kansas, Kentucky, Montana, North Carolina, North Dakota, South Carolina, South Dakota, Tennessee, Texas, Washington and Wisconsin exempt even the chauffeur from registration or the necessity for taking out a license.

In Connecticut all operators are licensed annually, fee \$2. In Delaware the fee is \$5. District of Columbia, \$2; Maine, \$2; Maryland, \$2; Massachusetts, \$2, with renewal 50 cents; New Hampshire, \$3, with renewal \$1; New Jersey, from \$2 to \$4, depending on horsepower; Oregon requires all operators to register as chauffeurs; Rhode Island, \$1; Vermont, \$2. In Virginia the annual license for the car's owner is included in the registration fee and is construed to cover members of the owner's family. Chauffeurs and others are taxed \$2.50.

In the other states which have laws children are prohibited from driving.

Of the thirty-eight states considered thirteen make no restrictions whatever as to the driver, while ten tax the chauffeur only. In eleven states all operators must register, the fee ranging from nothing in Oregon to \$5 in Delaware.

**Rights and Duties of the Non-Resident**

This section of the laws is one of the most important of all, as it touches upon the safety of the public as well as motordom. It is conceivable that a man of notorious reputation for carelessness, drunkenness or some other vital fault in New York, might go to Indiana, for example, and drive the private car of some wealthy man, when he could not do so on account of his record in his home state.

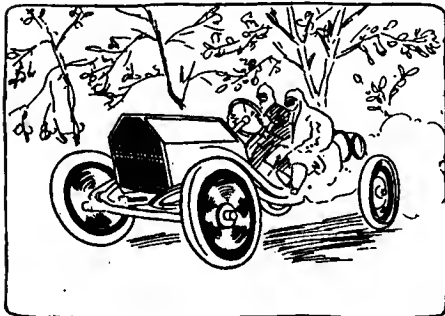

In Texas road racing is prohibited by law

The section of the laws that deals with the status of non-resident motorists shows some signs of uniformity.

In Alabama non-residents, upon compliance with the law of the state of

their residence and displaying registration number, are granted the same exemptions that are accorded residents of Alabama in the state in which the non-resident lives.

In Arkansas compliance with the law of one's own home state, displaying numbers and carrying lights is enough to gain exemption for the visitor. California does not mention the lights in granting exemption. Connecticut laws are similar, but provide for revocation of the exemption upon conviction for violation of any clause of the Motor Vehicle Act.

Reciprocity is the keynote of the Delaware provision as it is in the District of Columbia. Florida exempts registered automobiles for 30 days. Illinois does the same for 60 days in any one year, except in the case of foreign corporations.

The exemption in Indiana is wider and is granted to all cars that have complied with the law at home. Iowa has adopted a similar policy, save that it requires a reciprocal treatment. Kansas makes no provision in its law. Kentucky only asks that the car be legally clean at home.

In Maine an exemption of 30 days is granted to cars that have complied with home laws and driven by a person duly licensed to operate the automobile. Maryland partially exempts cars for two periods of 7 days each in one year providing non-resident's tags are secured from the commissioner of motor vehicles.

Massachusetts exempts visiting cars from registration for 10 days a year on a reciprocal basis. Half rates are charged visitors in summer who overstay that period.

Michigan requires that home law be satisfied and reciprocity

extended to her own citizens.

Minnesota places a 30-day limit on visitors without registration.

Missouri's limit is 20 days; Montana makes no provision; Nebraska, 30 days; New Hampshire, 10 days, but car must be driven by duly licensed driver. Half rates are charged visitors for the three summer months. New York is on a reciprocal basis except as concerns foreign corporations.

New Jersey: Non-residents are not exempt except under special driver's license, which remains in force for eight consecutive days or four periods of two days each; license issued by Commissioner of Motor Vehicles, or appointed deputy; fee, \$1. Non-resident corporations specially licensed to penetrate 15 miles into the state when registered at home and upon payment of \$100.

North Carolina allows outside automobiles to pass through without penalty. Others are not exempt.

North Dakota exempts registered cars and Ohio demands reciprocity as well as home registration. Oregon has a limit of 30 days; Pennsylvania, 10 days and reciprocity; Rhode Island, 10 days and provides that the exemption shall be revoked in case of violation of speed regulations.

South Carolina does not cover this point. South Dakota and Utah require that visiting cars shall be registered at home in order to claim exemption.

Tennessee and Texas make no exemptions. Vermont, Washington, West Virginia and Wisconsin grant reciprocal exemption and require home registration.

Virginia exempts visitors for two periods of 7 days each in any year.

New Jersey, Tennessee and Texas are the striking examples of the non-reciprocal idea in State laws.

New Jersey is particularly noted for its stringent law, the effect of which has been to lose all exemptions for touring Jerseyites in a score of important and agreeable states unless the Jerseyite pays for registration when he goes touring.

The ideal law on this subject would undoubtedly be a section that provided for the exemption of all outside cars that had complied with the law at home. In that case there would be no necessity for any definite clause providing for reciprocity.

**Equipment Commanded by Statute**

Under the head of equipment there is also a wide divergence. The Alabama law may be taken as a model in this classification. In fact, the Alabama law is quite clear and reasonable in all respects. It covers the following points with regard to equipment: Adequate brakes, suitable signal, two white lights in front and one behind, showing red to the rear and white on the number plate. Lamps must be lighted one-half hour after sunset until one-half hour before sunrise. The Arkansas statute differs from that of Alabama in that it provides that the front lamps must be visible 200 feet away and that the number must be

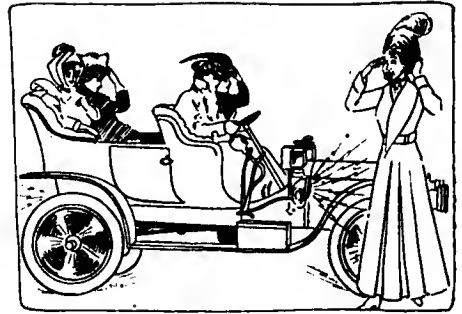

New Jersey prohibits noise on its highways

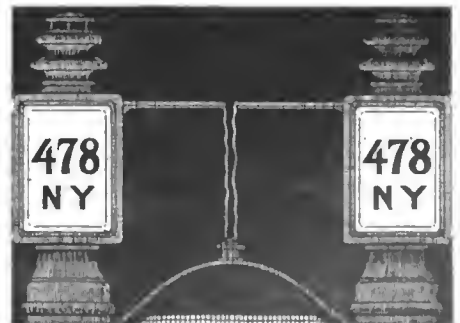

Arkansas requires numbers on front lamps

displayed on the glass front of the lamps. The motor must be shut down when the car is left standing.

California provides for showing the registration number on the lamps. In Connecticut there must be two sets of brakes and the muffler is required to be used after 9 o'clock at night within the limits of cities or boroughs.

Delaware requires two white front lights and a red tail lamp. In the District of Columbia a lock is commanded in addition to the usual provisions and a muffler is required. Whistle or signal and two lamps are all that are required in Florida.

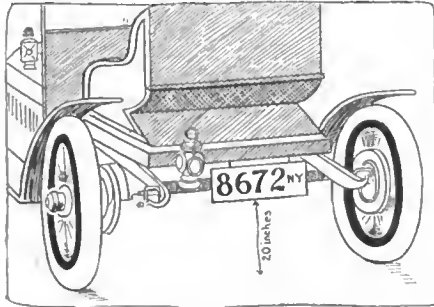

Some States insist on rear tags being at least 20 inches above the ground

In Illinois there must be brakes, signal, two white lamps in front and one in the rear showing red behind and illuminating the number plate so as to make it visible 150 feet. As a detail, it is ordered

that this plate shall clear the ground by at least 20 inches.

Brakes, lamps and signal are required in Indiana, Iowa, Kansas, but in the latter there need be only one front lamp. Kentucky demands brakes, signal and lamps, the front pair of which must carry the registration number. This is the law that caused such a rumpus among the Colonels recently, and which is still in the courts for construction.

Two brakes and a muffler are the features of the Maine law, while the Maryland statute provides that the front lamps be visible 200 feet. Unreasonable noise and smoke are prohibited in Massachusetts, while Michigan lays the ban upon anti-skid devices of all sorts except in wet, slippery weather. The muffler must be used in Minnesota within village or town limits.

Missouri only demands the three usual lamps with brakes and signal. Montana makes no special provision for equipment. Nebraska requires brakes, signal and one or more lamps in front and a red light behind. The muffler must be used in New Hampshire cities and villages.

New York makes the statutory requirement for brakes, signal and three lamps, the rear light illuminating the number plate so that it shall be visible 50 feet away.

Smoke is banned in New Jersey and lights only are required in North Carolina. North Dakota provides for signal and two lamps, one on either side. Ohio's law is similar to that of Alabama. In Oregon the registration number must be shown on the face of the front lamps. The Pennsylvania provision is like Alabama's. Rhode Island's is also, except that the use of the muffler is provided. South Carolina requires at least one white light in front, otherwise the law is the same as Alabama. South Dakota follows the lines of Alabama. In Tennessee only a signal is required. In Texas one lamp and a signal fills the legal requirements. Utah is like Alabama. In Vermont a muffler is required, lamps must bear registration number and a lock is ordered so that the car cannot be set in motion when left alone.

One lamp in front, at least, and a lock, as above, is necessary in Virginia. Washington commands that at least one white lamp carrying the number of the car shall be used. A muffler is also required in cities or villages.

West Virginia's law provides for a speedometer and for front lamps bearing the registration number. In Wisconsin at least one white lamp in front is required.

In all the states except Tennessee that are provided with automobile laws the statute commands the use of a lamp or lamps at night. In all but three states brakes and signals are required. Throughout the foregoing text, unless it is specifically excepted, the law requires lights, brakes and signals.

The Alabama law is excellently framed and covers the main points distinctly. This form of the law has been followed by eighteen states and probably represents the best general line to be followed. In the details of equipment practically all the states differ from one another. There are no two exactly alike, although, as has been said, eighteen are substantially so.

Two front lamps, distinctly visible for a reasonable distance, with one in the rear, showing red behind and shining sidewise upon the number plate, adequate brakes, suitable signal and a due regard for the use of the muffler would seem to embody the essentials of a model law.

### Chauffeurs in the Legal Contemplation

The phase of the law that deals with chauffeurs is badly scattered. The Alabama law on this subject is moderate and effective. It provides for annual registration and requires that applications must be endorsed by three reputable automobile owners. A badge is issued to successful applicants, which must be worn while operating the car. The fee is \$5, with a charge of \$2.50 for renewals. Non-resident chauffeurs are exempt if they have complied with the law of their home states.

In Arkansas the fee is \$1, and grafting is prohibited specifically. California charges \$2 for registration and non-residents are not exempt. No special provision is made for chauffeurs' registration in Connecticut, Delaware, District of Columbia, Maine, Maryland, Massachusetts, New Hampshire, New Jersey and Rhode Island, in each of which the law requires all operators to register and take out licenses before operating automobiles.

In Indiana, Iowa, Kansas, Kentucky, Montana, Nebraska, North Carolina, North Dakota, South Carolina, South Dakota, Tennessee, Texas, Washington and Wisconsin, the subject is not covered in any way.

Florida charges \$2 for registration and exempts non-residents engaged in driving non-resident cars for 30 days.

Illinois examines chauffeurs and the fee is \$5, with renewals at \$3. In Massachusetts a fee of \$2 is required for examination. Michigan, \$2, non-residents exempt if home law has been complied with.

In Minnesota the fee is \$3, with renewals at \$2. Non-residents are exempt for 60 days. Licenses may be revoked upon third conviction. Missouri, fee, \$1.50. The fee in New

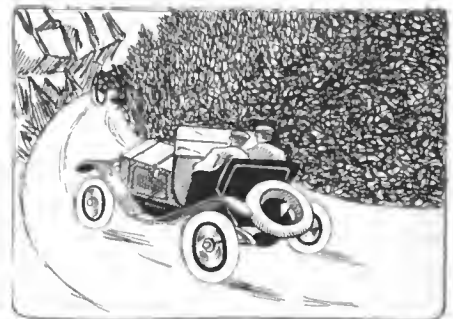

Only 10 miles an hour in New Hampshire when approaching a curve

Hampshire is \$5, with renewals at \$1. In New York the chauffeurs are required to take an examination and the fee is \$5 with renewals at \$2. The certificate bears upon its face the photograph of the chauffeur. After February 12, 1912, non-residents will be exempt upon complying with home laws.

Ohio charges \$2 for registration. Non-residents are exempt. Oregon requires all operators to undergo registration and charges a fee of \$2. Pennsylvania also charges \$2. So do Utah, Vermont and West Virginia. Virginia charges \$2.50.

### Speed Limits of the Various States

It is a patent fact that no person should operate an automobile unless thoroughly competent to do so. Therefore, the trend of opinion is setting toward the registration, examination and licensing of everybody who drives a car. On this basis the law of Connecticut is clear and definite and probably expresses the idea of a fair, safe law as well as any other statute.

Speed provisions vary as widely as do those covering any other phase of automobiling. A rate of 30 miles an hour for one-quarter mile is deemed presumptive evidence of recklessness

in Alabama. Arkansas places the speed limit at 20 miles an hour for 1-4 mile, with 6 miles an hour as the maximum speed in rounding a corner. California says 20 miles an hour, with 4 miles an hour as the limit on dams, sharp curves or grades. Connecticut marks the limit at 25 miles an hour, with 10 miles an hour on curves and crossings. Delaware 20 miles an hour; District of Columbia the same. Florida only requires a reasonable and proper rate without mentioning maximum figures, and insists on 4 miles an hour on bridges, curves and crossings. In Illinois 25 miles an hour is the limit, with the usual restrictions of speed in built-up sections. Racing is prohibited.

Indiana limits speed to 20 miles an hour, and provides for 6 miles an hour in passing a horse or other draft animal. Iowa says 25 miles an hour and Kansas cuts it down to 20 miles an hour. Kentucky sets the limit at 20 miles an hour; Maine, 25 miles; Maryland, 25 miles; Massachusetts, 20 miles, and provides for the sounding of horns at intersections of the road and at curves where the road is hidden from view. Michigan, 25 miles, with a limit of 10 miles an hour in passing pedestrian or horse. Minnesota, 25 miles an hour. Same for Missouri, Nebraska, New Hampshire, New Jersey, North Carolina, Oregon, Rhode Island, Vermont, West Virginia and Wisconsin.

Montana sets the limit at 20 miles an hour. New York allows 30 miles an hour, as does North Dakota; Ohio makes it 20 miles; Pennsylvania, 24 miles; South Carolina, 15 miles; South Dakota, 20 miles; Tennessee, 20 miles; Texas, 18 miles; Utah, 15 miles; Virginia, 20 miles; Washington, 24 miles.

In practically every state that has automobile laws there is a specific requirement for reasonable and proper speed. This is construed to be less than 15 miles an hour in South Carolina, and less than 30 miles an hour in New York, North Dakota and a few other states. The rate of 25 miles an hour is deemed reasonable in nearly a score of states, while another score insists that 20 miles an hour is about right, with due care in driving. Almost every state considered designates and specifies certain conditions under which speed must be reduced far

below the maximum figures. Almost every state specifies curves, bridges, crossings in this category, and many of them make it statutory to shut down when passing draft animals.

The idea of a speed limit is a difficult one to handle. It is conceivable

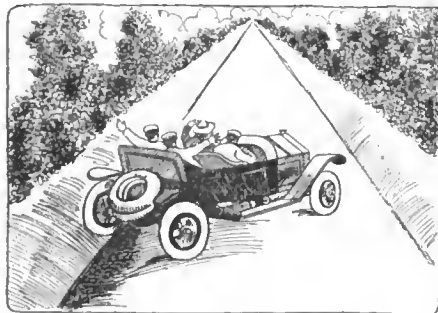

Non-skids not allowed on Michigan's crowned roads, except when snow or ice-covered

that a speed of 40 miles an hour might not be unsafe or unreasonable in some sections, and it is absolutely certain that 12 miles an hour is wildly unreasonable and unsafe in certain other sections. The essence of the law is to protect the public, the automobilists, property and the roads, and reasonableness is the fundamental principle involved. If racing were prohibited and reasonableness insisted upon in the matter of speed it would seem that arbitrary speed limits might be abolished.

#### Penalties for Breaking the Laws

As regards penalizations, the range runs between a fine of \$1 to imprisonment for felony, depending upon the gravity of the offense and the state in which it is committed.

In Alabama speed infractions or drunkenness may draw a fine of \$500, or six months in jail, with sweeping revocations of registration and license. Arkansas makes it \$100 for speeding and \$200 for racing; California, \$250 or 30 days; Connecticut, \$500 or 30 days; Delaware, \$200 or 3 months; District of Columbia, \$250 or 6 months; Florida, \$250 or 60 days; Illinois, \$200; Indiana, \$200; Iowa, \$500 or 2 years; Kansas, \$100; Ken-

tucky, \$50; Maine, \$50 or 10 days; Maryland, \$500 or 500 days in jail; Massachusetts, \$100; Michigan, \$100 or 30 days; Minnesota, penalty for misdemeanor; Missouri, \$500 or 60 days; Montana, \$100 or 60 days; Nebraska, \$100 or 60 days; New Hampshire, \$100 or 30 days; New York, \$500 or 5 years; New Jersey, \$500 or 20 days; North Carolina, \$50 or 30 days; North Dakota, \$50; Ohio, \$100 or 30 days; Oregon, \$150 or 75 days; Pennsylvania, \$200 or 1 year; Rhode Island, \$500 or 90 days; South Carolina, \$100 or 30 days; South Dakota, \$50 or 30 days; Tennessee, \$100; Texas, \$100; Utah, misdemeanor; Vermont, \$200 or 6 months; Virginia, \$10 minimum or 30 days; Washington, \$100; West Virginia, \$250 or 30 days, and Wisconsin, \$25.

The minimum punishment ranges down to a reprimand. In New York it is felonious under the Callan act for the driver of a car to run away after an accident.

Drunkenness is construed to be vastly more serious in the driver of a car than it would be under almost any other circumstances.

The technical penalties provided for violation of the speed limits are generally severe when it is considered that speed alone is not necessarily an evidence of reckless driving. It is admitted and urged by the majority of automobile owners that the provisions against recklessness cannot be made too strong. Take the recent Glidden Tour as an example. Virginia has a limit of 20 miles an hour, and the schedule of the big cars was 20 miles an hour. It is not possible to average that rate of speed without going 30 miles an hour in favorable localities. By the same token South Carolina's limit is 15 miles an hour. If either of these laws was enforced there could never be any fast touring in either state.

In the matter of the status of local ordinances it may be said that as a general thing they are prohibited where the state law covers the premises. In many of the states the posting of signs is provided. As a general thing the laws of the various states provide speed limits which must be observed in cities and villages.

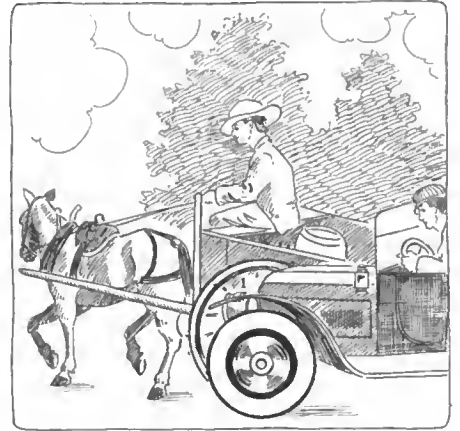

Only 6 miles an hour in Indiana when passing horse-drawn vehicle

#### London's Horse 'Bus a Thing of the Past

LONDON, Nov. 1.—The curtain was rung down on the scene of the horse-drawn omnibus in the streets of London on Tuesday, October 31, and to some old Londoners the end was a tragedy. On the day mentioned every horse-drawn omnibus was cleared from the London roads, thus putting an end to a traffic system whose romantic reign has extended back over a long period of years in the English metropolis. The change from horse-flesh to petrol, which was inaugurated in 1904, has been even more rapid in its revolutionary character than the most sanguine prophets anticipated. The first motor-omnibus started in London ran from Peckham to Oxford Circus.

Two motor omnibuses were put upon trial at Hastings, England, to ascertain the actual running cost of such vehicles. During 1909 the expenses of the 'buses averaged 23 cents per mile each. This outlay was cut to 20 cents per mile during the fiscal year ending recently. These 'buses were not, however, of the very latest types and it is estimated that 18 cents per mile will cover the running expense of the most modern pattern of vehicle.





Lining up for the start on Broad Street in front of the office of the Newark Star

## Twenty-seven Perfect in Newark Run

**N**EWARK, N. J., Nov. 3—In the golden sunlight of a perfect Autumn afternoon, twenty-seven of the thirty-four entrants in the Newark Star Endurance Contest drew up at the finish line with perfect scores. The run was conducted by the Newark Star, under the auspices of the Newark Motor Club. The route covered a 127-mile circuit through the most picturesque part of New Jersey.

Promptly at 6.45 in the morning, Mayor Haussling, the honorary starter, fired a shot from a revolver. This novel method of starting an automobile run sent off a big Mais 2 1-2-ton truck, which was followed by a Johnson 3-ton truck and the other cars. Each car carried an official observer, who kept accurate account of the time consumed in work on the car, as penalties were imposed at the rate of 1 point a minute, or fraction thereof. The rules provided penalties at this rate for

every stop made outside of Newark control except at Hackettstown fuel control, where water, gasoline and oil could be obtained. If these were taken on at any other point on the route a penalty of 3 points was imposed. Each contestant was required to cover the entire route in exactly 7 hours from the time of



Crowds gathered to watch the cars checking in at the finish



Auburn making good time on the last leg of the 127-mile route

starting under penalty of disqualification. The time for the trucks was 12 hours. For each minute early or late at the Newark control a penalty of a point a minute was incurred.

The first mishap of the run fell to the lot of the Johnson truck, which, in trying to avoid a stone-pile on one side of the road and a post on the other, plowed into someone's front lawn and sank in up to the hubs. After five hours' work the truck was released and proceeded, drawing up at the finish line at 1.45 a. m.

The Mais truck had no trouble until it struck a water-break at German Valley, and bent its drive shaft, which took two hours to repair. The truck finished at 9 P. M.

The McFarland No. 1 and the Jackson runabout were late in leaving the Newark control, checking out at 7.12, although their time counted against them. No. 1 became stalled on Hamburg Mountain and No. 22, a Maxwell, at Charlottesville, on account of tire trouble. The latter was stalled on North-



As the cars approached the checking station at Newton

field road as well, the penalties for the two occasions being two points. No. 3, the Paterson, had two punctures at Newton and a blow-out at Hackettstown. This car arrived so much ahead of time that it was penalized eight points. The Cutting, No. 6, driven by Frank Kramer, the bicycle champion, was fined one point because of a stalled motor. The Auburn runabout, No. 15, was penalized two points for stopping the car near the tape. It was one minute behind time. No. 4, the Metz runabout, was fined one point for faulty equipment. The Schacht, No. 29, was fined one point for stopping the motor in Hackettstown.

Each of the cars making perfect scores received a beautiful silver cup, and each driver a handsome medal. Horace A. Bonnell, manager of the Automobile Board of Trade, had charge of the contest. The summary:



The Johnson truck was laid out early, but continued to the finish

No.	Name of Car.	H.P.	Driver	Penalties
2	Jackson	30	J. D. Nicol	0
5	Ford	22	C. B. Wyckoff	0
7	Penn	30	G. M. Reynolds	0
8	Correja	35	E. G. B. Riley	0
9	Haynes	30	E. R. Schuyler	0
10	Stevens-Duryea	36	G. F. Eveland	0
11	Buick	18	Walter Davenport	0
12	Cadillac	32	C. E. Fisher	0
14	American Tourist	30	Ray Magruder	0
16	Auburn	40	J. J. Meyer	0
17	Hudson	33	R. B. Mann	0
18	Reo	30	P. Haycock	0
19	Lion	40	F. L. Appar	0
20	Lion	40	M. H. Appar	0
21	Maxwell	36	J. W. Mason	0
23	E.M-F	25	L. F. Pfeifer	0
24	Ford	22	R. E. Gillam	0
25	Flanders	20	M. H. Jolly	0
26	National	40	H. C. de Raismes	0
27	Cole	35	J. B. Wallace	0
28	Premier	40	Herman Peterson	0
30	Oakland	30	Thomas Buchner	0
31	Correja	35	F. J. Rodel	0
32	Washington	40	H. O. Carter	0
33	Lion	40	R. C. Clements	0
34	Oakland	30	C. J. Maier	0
35	Herreshoff	22	L. J. Blanchard	0
1	McFarland	40	Thos. McGuire	1
3	Paterson		M. F. O'Neil	8
4	Metz	22	W. H. Samuel	1
6	Cutting	32	F. L. Kramer	1
15	Auburn	30	Peter Dexheimer	2
22	Maxwell	25	C. F. Briggs	2
29	Schacht	40	J. M. Gray	1
48	Johnson—3-ton truck	40	V. Richardson	Dis.
50	Mais—2 1/2-ton truck	35	C. Rohertson	Dis.



The Schooley Mountain district offered magnificent views—showing the Oak Ridge Reservoir and the excellent road

# Molines, Staver and Grout Winners



Scene when the contestants in the reliability run of the Chicago Motor Club stopped at the noon control at Lexington, Ky.

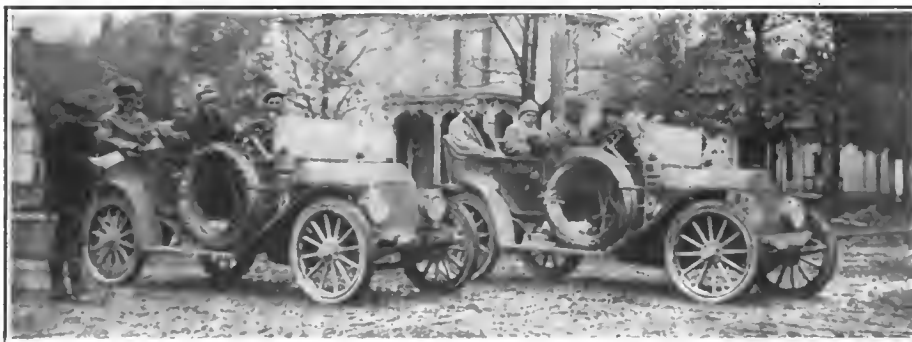

Moline team in touring car class—No. 2 clean score



CHICAGO, Nov. 5—That automobiles are being made better each succeeding year is well demonstrated by the performances of the seventeen cars that contested in the 7-day reliability run of the Chicago Motor Club which ended in this city this evening. Of the seventeen cars that started in the run nine reached Chicago to-night with perfect road scores.

A perfect road score meant that the car had traveled on its 20 or 18-mile-per-hour schedule during the run and that no adjustment had to be made on the car during the road work. Two or three years ago it was a wonder if one car made a perfect road score, but to-day under stricter rules over 50 per cent. of the cars have ended with clean scores for the road work. This is what appeals to the car owner, for what owner wants to be held up along the road for any car troubles? He does not mind having to make some little repair in his garage at the end of the day's run, but does object to having to stop in the middle of a muddy road or on a city street to make such a repair.

But the winners of perfect road scores did not necessarily mean winners of the contest. After the road work was over

each car had to take its brake test, its clutch test, its motor test and was given a technical inspection of one-half hour in which every broken, bent or loose part on the car was looked for and penalties, according to the fixed penalty rules of the American Automobile Association, imposed. After it was all over two cars were tied for the touring car trophy, and a winner was declared in the runabout class. A Moline and a Staver tied in the touring car division. Both had perfect scores on the road, perfect scores in the brake test, perfect scores in the clutch and motor tests

and perfect scores when the technical inspection was completed. They share equal honors and each will receive a trophy. Salisbury drove the Moline which carried No. 2 banner and Knudsen drove the Staver which was No. 10 in the test.

In the runabout division another Moline was the winner. It was driven by J. A. Wicke, who has piloted cars of this make in several Glidden tours and in previous runs of the Chicago Motor Club. He had a perfect road score, passed perfect brake, clutch and motor test, but lost 4 points in the final inspection. He had a water leak at the top of the radiator where the return pipe to the motor is attached to the upper tank part of the radiator. The victory gives to his company the Van Sicklen trophy put up a year ago and which trophy has to be won three times before becoming the permanent possession of the winner. Last year the Moline tied with the Fal on this trophy and by the agreements then made the possession of the trophy for the first year was to be determined this season. As the Fal was not a contestant in this run, the winning of the trophy for last year goes to the Moline by default. The Moline now has two legs on this trophy.

In the touring car division there were nine contestants and in the runabout class, eight, the complete penalizations for road-work, brake tests, clutch and motor tests appearing on the opposite page.

In addition to the winners of the touring car and runabout

TABLE SHOWING THE RESULTS OF THE FIFTH ANNUAL RELIABILITY CONTEST OF THE CHICAGO MOTOR CLUB.

No.	Car	Driver	1st Day		2nd Day		3rd Day		4th Day		5th Day		6th Day		7th Day		Brake Test		Final Examination		Economy Competition													
			Time	Work	Time	Work	Time	Work	Time	Work	Time	Work	Time	Work	Time	Work	Time	Work	Total Road Score	Service	Emergency	Total Penalization	Clutch	Gearset	Motor Test	Final Inspection	Grand Total Technical and Time Penalties	Position	Gasoline in Gals.	Weight	Miles per Gal.	Percentage		
<b>Touring Car Division</b>																																		
2	Moline	P. G. Salisbury	0	0	0	0	0	0	0	0	0	0	0	0	0	0	0	0	0	0	0	0	0	0	0	0	0	0	2	77½	3740	17.48	378	
10	Staver	E. T. Knudsen	0	0	0	0	0	0	0	0	0	0	0	0	0	0	0	0	0	0	0	0	0	0	0	0	0	3	82	3900	16.54	371		
1	Moline	C. H. Vandervoort	0	0	0	0	0	0	0	0	0	0	0	0	0	0	0	0	0	0	0	0	0	0	0	0	4	7	82	3750	16.54	357		
5	Halladay	Geo. H. Daubner	0	0	0	0	0	0	0	0	0	0	0	0	0	0	0	0	0	0	0	0	0	0	0	0	10	105	4280	12.90	311			
3	Case	J. Hanson	0	0	0	0	0	0	0	0	0	0	0	0	0	0	0	0	0	0	0	0	0	0	0	0	22	21	103½	4090	13.10	308		
9	Staver	G. Monckmeier	0	0	0	0	0	0	7	0	0	0	0	5	0	0	0	0	0	0	0	0	0	0	0	0	5	5	81½	3790	16.63	363.305		
6	Halladay	W. M. David	0	0	0	0	0	0	0	14	0	0	0	0	0	0	0	0	0	0	0	0	0	0	0	0	8	9	102½	4260	13.29	326		
7	Oldsmobile	C. R. Winters	0	0	0	0	0	0	238	217	0	2	0	0	0	0	0	0	0	0	0	0	0	0	0	0	26	14	210½	6030	6.44	223		
8	Abbott	A. M. Robbins	0	0	0	0	0	0	0	0	0	0	0	48	70	1000	1118	Withd r'n	0	0	0	0	0	0	0	0	0	0	0	0	0	0	0	0
<b>Runabout Division</b>																																		
100	Moline	J. A. Wicke	0	0	0	0	0	0	0	0	0	0	0	0	0	0	0	0	0	0	0	0	0	0	0	0	0	4	8	84½	3750	16.09	340.3	
102	Oakland	H. A. Bauer	0	0	0	0	0	0	0	0	0	0	0	0	0	0	0	0	0	0	0	0	0	0	0	0	7	12	94½	3340	14.38	276		
105	Bergdoll	Ad. Monsen	0	0	0	0	0	0	0	0	0	0	0	0	0	0	0	0	0	0	0	0	0	0	0	0	7	6	74½	3450	18.25	363.3005		
103	Velie	A. H. Gibbons	0	0	0	0	0	0	0	0	0	0	0	0	0	0	0	0	0	0	0	0	0	0	0	0	20	13	113½	3620	11.92	250		
104	Velie	J. H. Stickney	0	0	0	0	0	0	0	0	0	0	0	0	0	0	0	0	0	0	0	0	0	0	0	0	41	15	137	3490	9.90	199		
101	Moline	W. J. Boone	0	0	0	0	0	0	0	0	0	0	0	0	0	0	0	0	0	0	0	0	0	0	0	0	54	4	81½	3830	16.69	368		
107	Grout	H. E. Halbert	0	0	0	0	2	40	92	248	0	0	50	3	30	8	473.63	40	13	0	0	0	0	0	0	0	8	1	77	4010	17.60	406		
106	National	Paul Strous	0	3	14	13	0	0	0	0	0	0	11	0	1000	1041	Withd r'n	0	0	0	0	0	0	0	0	0	0	0	0	0	0	0	0	

divisions there were two other winners. The first was the winner of the team trophy, a team consisting of any two cars of the same make whether in the touring car or runabout divisions having the lowest score. The winning team is made up of two Molines, Salisbury with a perfect score and either Van Dervoort or Wicke, with 4 points each, making a total penalty of 4 points for the team.

The fourth trophy was the economy trophy carried off by No. 107 Grout, driven by Halbert. This trophy was donated by the Standard Oil Company and was won outright. It was given to the contestant showing the best efficiency performance under the economy formula of the club. This formula takes into consideration the weight of the car, the distance traveled and the gasoline consumed. The product of fuel used and distance traveled is divided by the weight of the car. In this formula it does not necessarily follow that the car making the trip on the least gasoline is the winner; in

fact, Bergdoll used a few gallons less than the Grout, but was several hundred pounds lighter.

All these results were not reached without a process of elimination. First, there came the long tour itself, a journey of 1355.7 miles through five States, with night stops at Indianapolis, Louisville, Cincinnati, Columbus, Detroit and Grand Rapids, which eliminated eight of the cars. Then came the brake and clutch tests Saturday morning, which still further reduced

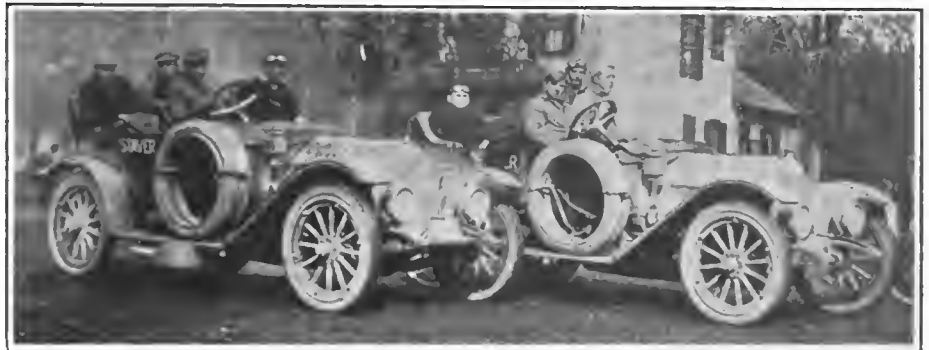

Staver team in touring car class—No. 10 clean score.



National, Velie and one of the Molines. 10 miles from Lansing, Mich.





Moline roadsters—No. 100 won first place in its class



Abbott and two Moline 10 miles out from Georgetown, Ky.



Pilot Velie and Oldsmobile, 15 miles out of Louisville



Scene at the noon control at South Bend, Ind.

the field, while the technical examination as conducted by F. E. Edwards, George W. Gaidzik and supervised by David Beecroft, completed the task of evolving the winners.

To the Moline belong the chief honors of the long contest, for in addition to tying for the touring car cup and winning the Van Sicklen trophy in the roadster section and taking the team prize, all four Molines went through with perfect road scores. Three of these were penalized in the technical examination. Van Dervoort's No. 1 Moline was given 4 points for a loosened radiator support. The Wicke Moline roadster also drew 4 points for a leaky radiator union, while the Boone Moline roadster was given 54 points for a broken starting crank bracket and a loose radiator support.

The Staver-Chicago came into the limelight through the fine work of Knudsen, who not only had a perfect road score but also handled his car so well that the technical committee could find nothing wrong when it was subjected to a rigid test. The other Staver was sixth in the final rating, its main trouble being a front wheel bearing which cost it its road score and brakes in that test.

Halbert in the Grout started in the test with the idea of winning the Standard Oil Company's fuel economy trophy, which last year was taken by the Cunningham. The Grout was a class winner in the Chicago economy test last Spring and Halbert was out to repeat. After he lost his perfect score the second day he devoted all his time to saving fuel, with the result that he put his big roadster through the run on a fuel consumption of 77 gallons. This was a trifle more than was used by the Bergdoll, but the weight of the Grout enabled it to top the list.

When the tour was completed it was found that perfect road scores had been made by No. 2 Moline, No. 10 Staver-Chicago, No. 1 Moline and No. 5 Halladay in the touring car class and by No. 100 Moline, No. 101 Moline, No. 102 Oakland, No. 103 Velie and No. 105 Bergdoll. Of the others, the Abbott-Detroit and the National roadster did not finish, the former withdrawing at Niles, Mich., the last day, because of the broken spring, while the National roadster overshot a turn near Hobart and was stuck in the sand, being left there over night by its owner, Paul Strauss, who was satisfied to seek shelter in a neighboring farm house.

Notwithstanding the fact that only two of the cars went through the entire contest with perfect scores, both road and technical, the results of the trial are something of which the entire motor industry may be proud. Most of the penalties were brought about by spring troubles, and in two instances the elimination can be traced entirely to accidents. The Oldsmobile Autocrat was running perfectly until a gasoline connection sprung a leak going into Washington Court House last Tuesday. This necessitated taking off the body to repair the damage, which of course meant a big time penalty. Then, to add to the misery, the big car, while leaving Washington Court House, skidded passing a team and dropped partly into a ditch, getting in a position where it could not secure traction which made it necessary to get a team to climb out. This brought on the bulk of the Oldsmobile's penalties.

With the Case it was running perfectly until leaving Detroit. Avoiding a woman getting off a street car, the car hit a curb, which resulted in penalizations that put it out of the running. The big Abbott-Detroit can trace its fall to a spring breaking while inside the city limits of Cincinnati. Dan Boone probably would have gone clean with his Moline had it not been for a weak dry cell which made trouble for him while starting on Wednesday. Boone cranked so hard he broke the starting crank bracket.

Another source of trouble was caused by broken fender irons, several being penalized for loose fenders and broken brackets. It is figured that some make mistakes by drilling holes in the fender irons, which weaken these parts and cause breaks. Instead of drilling holes, it is suggested to clamp irons to the brackets so as to resist jars and strains of a long run.



Brakes also caught some, but it is a remarkable fact that the report shows that on every car so penalized that one of the brakes was working well. Six caught demerits here. Where one brake was holding well the other was not so good.

Turning to the other side of the picture, one finds that not a single case of engine trouble developed among the seventeen cars on the 1355-mile journey. Every engine was hitting on all four cylinders in the motor test Saturday morning, despite the severity of the run. The National was penalized for carbureter adjustments and perhaps some might claim this to be engine trouble, but here there are extenuating circumstances. Strauss, driver of the National, is the owner of the car, and this was his first contest. In starting from Chicago he discovered the carbureter was not set for those conditions, and he had to change it three times before the engine ran right.

Not a case of axle trouble was reported. Before the run started the technical committee examined each car, taking the measurements from the felloe of the front wheel to the felloe of the rear one at the ground, and allowing 1-4-inch variation. Looking over the axles at the finish of the run it was found that each trimmed to 1-16 inch. No case of a broken wheel was reported, whereas in previous tests it was discovered that there were weaknesses. No leaks in radiator construction were unearthed, Wicke's penalty being for a leaky connection.

If the Chicago Motor Club had tried to order varying weather and road conditions in order to give the cars a test that would include everything in these categories it could not have succeeded better. As far as Indianapolis the weather was balmy and roads good. Then it sprinkled from Indianapolis to Louisville, although the stone roads were so good it made little difference. Going from Cincinnati to Columbus the roads were heavy because of rain, and the weather cold and disagreeable. From Columbus to Detroit there was a stretch of road that should make the States of Ohio and Michigan ashamed of themselves. From Toledo to Detroit the going was so abominable that it was necessary to change the routing.

From Detroit to Grand Rapids the weather was cold and the skies cloudy. The roads, too, were not of the kind found in southern Indiana and Kentucky, but still not so bad as to worry anyone. It was on the final day of the tour that the prize package was delivered. Leaving Grand Rapids under a cloudless sky, but with the temperature so far down that the tourists were in danger of being frostbitten, the tour had not gotten more than 20 miles out of town when traces of snow were discovered. The farther the tour progressed the deeper became the snow until the climax was reached at Niles, Mich., where an 18-inch snowfall was encountered. The conditions somewhat resembled those that attended the running of the New York-Paris race. This snow belt, however, disappeared in the afternoon, and the last traces were lost at New Carlisle, 45 miles from Chicago. From that point into Chicago the cars were kicking up dust and the weather had moderated so that the trip really was enjoyable. It was hard getting into the city because south of Gary the old Hobart road was torn up, making a detour necessary, while the usual course from Gary into East Chicago was blocked, making it necessary to go to Hammond before straightening out for the dash for the last tape.

The tour from Columbus Wednesday morning to Chicago Friday night saw the elimination of only two of the cars that had perfect scores up to that point, and those two dropped the same day, Thursday, going from Detroit to Grand Rapids. The Abbott-Detroit lost out when a gasoline line clogged and on top of this came the spring trouble which had started in Cincinnati. The Case was put out in Detroit, when it encountered the street car incident. On Wednesday the No. 9 Staver and No. 7 Oldsmobile were penalized 5 to 2 points, respectively; on Thursday the Case drew 4 points, the Abbott-Detroit 118, the Grout 53 and the National 11. On the last day the Oldsmobile drew 6 more points and the Grout 38, while the Abbott-Detroit and the National withdrew.



Grout No. 107, winner of the economy test.



Stretch of excellent road outside of Dayton, O.



Oakland, No. 102, which tied for second place in roadster class.



Stopping to put on chains, 30 miles out from South Bend, Ind.

# Road Conditions Truly Indicate the



1—Back Creek will long be remembered by the Glidden tourists  
2—Near Fairfield the road looks better than it is in reality

3—Leaving Roanoke the road is largely red clay and generally rough  
4—Rough spot near Midway, but vastly better than it is a mile ahead

**C**ERTAIN portions of the so-called National Highway are jokes and most of the imitations of roads included in the main Eastern route to the South are located in Virginia. On the other hand some of the best stretches of road between New York and Jacksonville are also in Virginia. Therefore, a ride across the Old Dominion involves all the pleasures and pains ordinarily to be met with on an automobile tour and many that come under the head of extraordinary.

There are miles and miles of fine macadam, stone roads and excellent dirt highways; there are also many miles of clay road, fair in dry weather and all but impassable when it is wet; dozens of miles of excessively rough and uncared for road; two score fords of varying width and depth and a score of toll-gates.

Speaking of the latter it may be said that the toll-gates are thickest where there is the least apparent reason for them as judged by the character of the roads. This, however, is a well-known characteristic of toll-roads.

In preparing for a run through Virginia, the tourist would do well to provide an ample supply of anti-skid chains, the same being not less than six chains, so that if bad weather should intervene he will not have to abandon his car in the hills and proceed by train. He might have to do it anyway if the fords happen to be unusually deep.

The improved section of the highway across the State is mostly north of Staunton. The worst parts of the road are south of the Natural Bridge to within 8 miles of Roanoke and

south from Roanoke to the North Carolina line. A good part of these roads was built by General Greene in the Revolutionary War period and slightly improved by Stonewall Jackson and General Lee in the Civil War time and shows few traces of improvement since. In the poverty-stricken mountain section, where the people live by hunting and nutting, raising only enough razor-back pork and garden truck to supply their own excessively simple needs, the roads do not warrant the name.

Wherever the roads are good in Virginia and as a general proposition, elsewhere, the people are prosperous, intelligent and thrifty. Where they are bad, opposite living conditions obtain.

The difference between the country people of the Shenandoah Valley and those of the Roanoke Valley is startling. In the Shenandoah the farmers and horticulturalists raise as fine apples and fruit as can be found anywhere on earth. The members of the recent Glidden Tour sampled the produce all along the line from New York to Jacksonville and they unanimously award the palm for fine apples to the Shenandoah Valley. In the Roanoke Valley, outside of, and entirely separate from, the big, busy, thriving city of Roanoke, the condition of the people is lamentable. When the caravan passed their way, the only glimpse caught of the mountaineers was when the cars traversed some cross-road and for a fleeting moment the tourists saw groups of lanky, uncouth men, usually mounted and universally carrying long rifles strapped across their shoulders. Some of them were questioned and it was learned that little or no agricultural produce

# Measure of Virginia's Prosperity

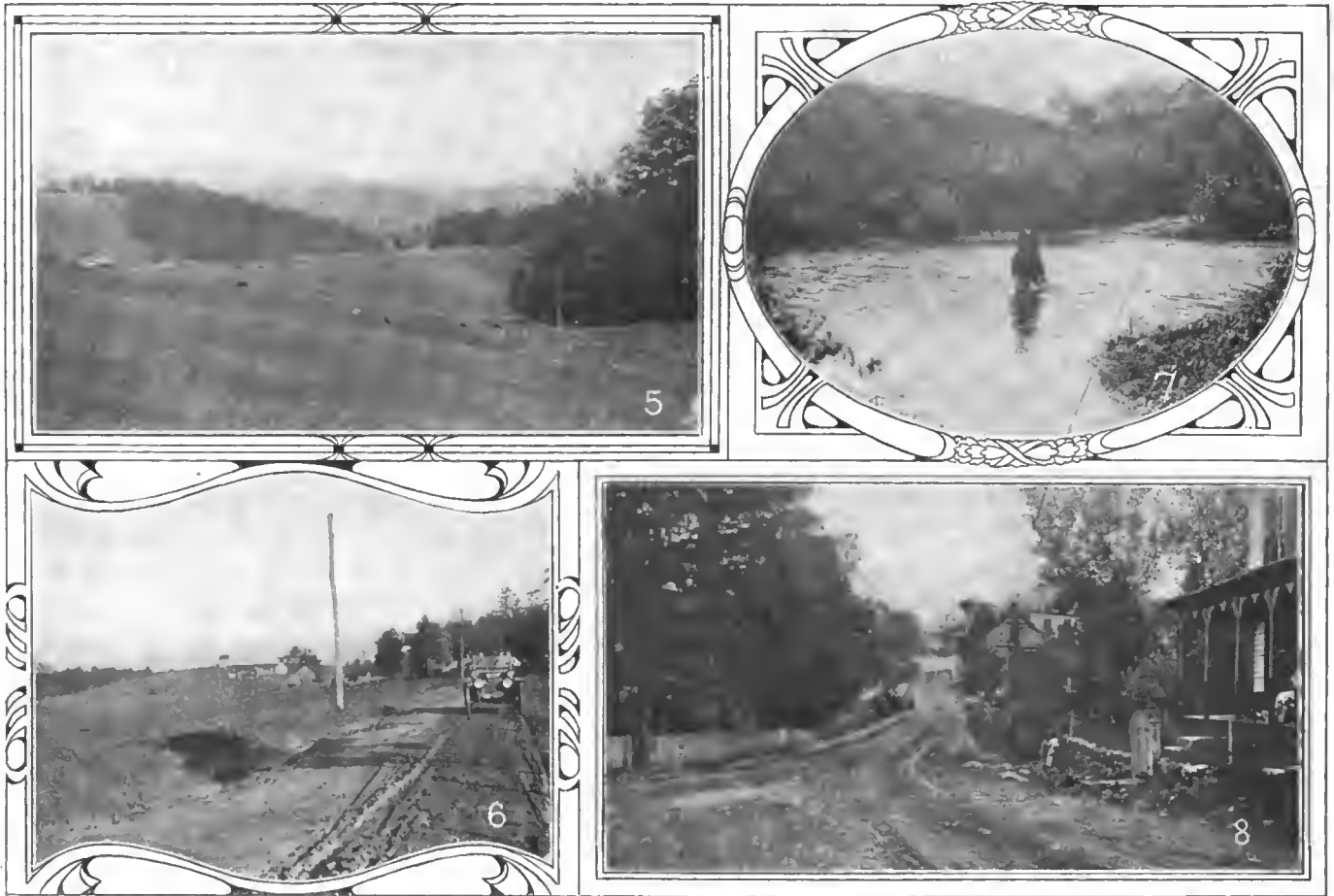

5—The Shenandoah Valley presents scenes of pastoral beauty  
6—Near Rocky Mount—a typical section of the best roads in the locality

7—Little Chestnut Creek is likely to cause trouble in wet weather  
8—Roads are generally good entering and leaving Virginia cities

was grown for market and the chief sources of income were the chase, guiding parties of hunters and seeking wild nuts in the woods. Education is a negligible quantity and physical attractiveness is wanting. Needless to say, the roads through this section are horrible.

Virginia, nevertheless, understands the value of good roads and paradoxical as it may seem, the State and counties have done an immense amount of work toward securing them. Just what progress along this line has been made can only be appreciated if one made a trip through the State several years ago and then again this Fall, noting the differences and improvements.

It is 109.8 miles from the Virginia-West Virginia line to Staunton, following the route of the Glidden Tourists. The road enters the Old Dominion 2 miles south of Rippon, W. Va. Almost the first thing the tourist will notice is a small ford, just across the State line. This could be bridged with a stone culvert at little expense and to the great advantage of users of the road. The road surface is good, being composed of stone base and fairly well maintained. There is another ford a little further on that should be bridged and then the tourist comes to the first toll-gate. Berryville, a place of 1,000 inhabitants, is the first settlement to be reached in Virginia.

Every foot of the country south from this place was battleground during the Civil War. Each hill was the scene of a fight; each valley was once the stage setting for war in its most

terrible form. Even the toll-gate just outside Berryville was once the center of a wild struggle between Mosby and Custer.

The road continues good, despite the toll system for many miles. The road corporations, in which it is said that the State of Virginia is a large shareholder, are chary about spending good money in bridging fords and water holes, but there is evidence that much work has been done to keep the roads in good condition.

Winchester, lying at the gate of the Shenandoah Valley, is rich in historic association. The town and its tributary section are also rich in almost everything else that goes to make up the sum total of human well-being except that it has no real hotel. The people of Winchester are all associated with agriculture in one way or another and as intelligence has been applied to the pursuit of agriculture in this territory, everybody has money and the town and territory own nearly 1,000 automobiles.

From Winchester to Staunton the tolls amount to \$4.75 and except in spots roads are good enough. Through the battlefields of Winchester which were taken and retaken seventy times, according to local lore and historic record, the road traverses Cedar Creek, Fisher's Hill and Newmarket, all of which witnessed sanguinary struggles and the road itself was followed by General Sheridan when he made his celebrated ride from Winchester to the point 20 miles away where his troops were being crushed by the gray legions.

The way leads through Kernstown, Stephens City and Middle-



One would hardly expect to find such a scene near Harrisonburg

town to Strassburg, and skirting the hillside of the mountains to the East, passes along the North fork of the Shenandoah river through Tom's Brook, Maurertown, Woodstock, Edinburg, Hawkinstown and Mount Jackson. The stone pike is fine all along here, but upon approaching any of the little towns and villages it will be noticed that the road becomes very rough and in passing through the towns, there is little evidence of an improved pike. This is particularly true after getting South from New Market and Lacey Spring and approaching such places as Harrisonburg.

Harrisonburg is a funny little village. The land about town is poorer than the average in the Shenandoah valley and the people are on a par with the land. It might almost seem as if the treasury was bare and that not a cent more could be wrung out of the natives by the ordinary processes of the tax-collector. Outside of the fact that the road entering Harrisonburg is worse than it is anywhere in the valley, making fast progress a physical impossibility, a small, non-assertive sign at the town limits states that the speed limit is 8 miles an hour. It is probably within the realm of possibility to drive 12 or even 15 miles an hour if one cares nothing for his car. The spirit of Harrisonburg was delightfully displayed when the Glidden Tour passed through.

A large thick individual, wearing a black beard and dressed after the mountaineer style, deftly placed his hat over the warning sign when the first car came along. When six or seven cars had passed, this fellow sought a telephone and advised the officials at the next toll-gate to hold up the caravan.



Winding country road near Greenville—this is full of small bumps

It is possible that some of the cars did make 10 miles an hour in going through town and later their drivers had to pay the fines assessed. Harrisonburg was richer by the sum of \$39.45 as the net result of the tour.

Mount Crawford, 6 miles to the south, also has an unenviable reputation but none of the tourists were stopped or fined.

From Mount Crawford to Staunton, the stone pike is good.

Staunton, which is pronounced as if it did not have a u in its first syllable, is a prosperous, lively and progressive place, of about 12,000 inhabitants. It is quite an educational center and is the home of the Staunton Military Academy and various female schools. Its attitude toward publicity can be accurately gauged from the single circumstance that when the Glidden Tour rolled into town, it was greeted by the paraded cadet corps of the military school at Present Arms. Staunton owns a large number of automobiles and is not in any way in sympathy with the attitude of such places as Harrisonburg.

The mileage from Staunton to Roanoke is 90.8 and it should only be essayed after a dry spell of weather. The road out of Staunton is excellent macadam for nearly 5 miles, being succeeded by rough dirt roads, that are not bad in dry weather. The road begins to climb immediately after leaving Staunton and in the first hour, the huge bulk of the Blue Ridge begins to loom in prospect. But after passing Greenville the road improves and



The back-bone of the Blue Ridge makes progress slow and uncomfortable

there is ample evidence of considerable highway work. This is particularly noticeable in the reduction of grades and straightening of the road just outside of Greenville.

The first dose of clay is encountered south of Midway and from there to Fairfield and Timber Ridge, high in the hills, the way would be uncomfortable in wet weather. There has been considerable grading, cutting and draining in the construction of the road from Timber Ridge into Lexington. This quiet university town is the seat of Washington and Lee University and the Virginia Military Institute and is proud of the fact that the bodies of Generals Lee and Jackson rest within its borders. An intensely interesting half hour may be spent in seeing the tomb of Lee. After the Civil War, General Lee was elected president of the university and died in 1870. His body rests in a chapel on the campus, furnished with so much plainness that it tells the story of the South's poverty after the war with wonderful distinctness. In the sanctuary of the chapel there is a full length figure of the great soldier, lying at rest, attired in the uniform of a full general. In the crypt, where his body actually is buried, a candle burns on the stone floor in front of the masonry that contains the clay of Lee.

Leaving Lexington, there is a good macadam road for 4 miles after which follows 7 miles of the roughest highway of the trip. The summit lies only a short distance from the end of the



macadam. From the high point the road winds up and down between the hills which narrow the valley almost to the size of a canyon. Then comes 5 miles of good macadam which brings the tourist to Natural Bridge. From the road, Natural Bridge is a disappointment. In fact it can not be seen at all, but by paying \$1 a head, tourists may stop at the hotel located there and walk down below the bridge. It is a great hollow cut in the limestone by water action and the arch is high enough to contain a skyscraper building.

There is a tremendous down-grade immediately after leaving the bridge and extending spasmodically to Buchanan, where the road crosses the headwaters of the James river. This road is graded in sections but otherwise unimproved. It is classed as a dirt road but in reality it is red clay, mixed with native earth and in wet weather is so slippery that a pedestrian can barely stand upon it. Woe be unto the automobilist who is obliged to change a tire in a rainstorm thereabouts. Nobody has yet shown the nerve to erect a toll-gate on this stretch of road. Purgatory Mountain has been robbed of most of its terrors through the improvements that have been made in and close to the village of Buchanan. In dry weather the foregoing stretch of road is generally passable at very moderate speed. In wet weather the tourist takes his life in his hand when he attempts it.



Magic scenic effects are presented panoramically in the Shenandoah

From Buchanan to Cloverdale the going is fair and from Cloverdale to Roanoke, a matter of 8 miles, there is a splendid macadam road that winds dangerously around numerous hillocks into the city. While some of the Glidden cars made as high as 58 miles an hour in the terrific rainstorm over this particular stretch of road, the dangers of high speed, even in dry weather, will be very apparent to any tourist.

For 40 miles south from Roanoke, the roads are indescribable in wet weather. But if there has been a dry spell of a week or more the scenic grandeur in which they are set would repay the suffering they must cause to automobile tourists in passing over them.

Circling Mill Mountain, one of the show spots of the section, the road mounts a stiff grade through red clay for about 5 miles, where a heavy down grade is met. At the bottom of this grade is found the left fork of the Roanoke River, known locally as Back Creek. If there has been rain in the hills the night before, beware of Back Creek. It was here that nearly half of the Glidden Tour stalled impotently while the swirling water hummed merrily through the under-pinning of the cars after short-circuiting the magnetos. Such treatment is outrageous for as useful and valuable a bit of mechanism as an automobile and the effects of the flood were apparent in the Glidden caravan all the way to Jacksonville.

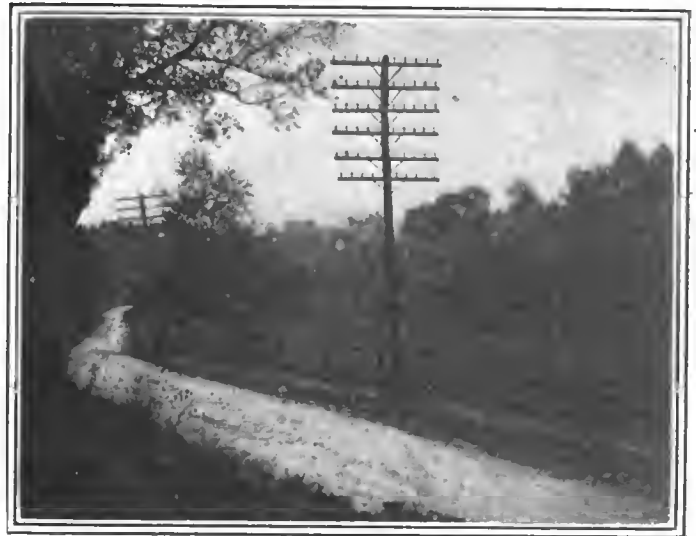

One of the few stretches of improved road near Lexington

After getting across this ford, which could be bridged permanently for a comparatively small sum, there is a steady climb for 5 miles through mountains, that rival anything in the world for scenic effects.

The poorest country passed during the trip will be found immediately after reaching the summit. Houses are unpainted, children clothed in calico and without foot covering and a general air of unthrift and lack of purpose. The roads are unimproved and through the hills to Martinsville are a fierce trial to car and passengers. Fords and gullies follow one another in rapid succession and the impossibility of regular wagon traffic over the roads in their present condition was the most salient fact impressed upon the Glidden tourists in passing.

At Martinsville there is a considerable improvement and for the remainder of the 75 miles that lie between Roanoke and the North Carolina line the road grows better with the passage of each mile. There are a number of stiff grades but the fords in this section of the road have been bridged and there is ample evidence of more wealth, intelligence and industry than appears a little further north.

The road through Virginia is 276.3 miles long. At least 75 miles of this is unimproved and unfit for travel during wet weather. There are thirty-seven fords of various sizes ranging from that across Back Creek to small runs that barely wet the tires in passing. Besides these things it must be acknowledged that the pike through the Shenandoah Valley makes good riding in comparison with the rest of the trip.



Leaving Timber Ridge, the highway is excellent for a short distance



## In the Making of a Radiator



THE Livingston radiator is of the zigzag tube type. The water enters the top of the radiator, according to the usual custom, and passes through the various tubes until it reaches the bottom, whereupon it flows into the water outlet pipe and into the cooling water inlet of the engine. The shape of the tubes is peculiar and gives the water a very devious course as it flows on its way. Each tube is of the same width as the radiator and of such a shape that the water passes through a distance equal to double the length of the radiator from top to bottom. This is effected by the water having to

pass alternately through a horizontal space of tubing equal in length to each vertical space through which it passes. The tube consists of a number of unclosed squares, the lower side of each forming the upper side of that next below it.

A series of these tubes placed alongside of one another gives the effect of a honeycomb. The air is drawn through the open spaces between the tubes and cools the water which passes through them.

Simplicity and speed feature the manufacture of this radiator. The raw material is transformed into the finished product by a series of operations which progress step by step with as little lost time or effort as could be possible in a process of manufacture which involves the various progressive steps toward the completion of the work.

The bronze of which the radiators are made comes to the factory in rolls of different widths, which are used according to the purposes for which the radiator is required. The sheets of bronze are placed upon a spindle of a machine which is adapted to carry any size roll required. Below the spindle carrying the first roll there is a spindle which carries another roll of bronze which is slightly wider, for a purpose which will be seen later. The metal passes from the roll into the machine and is led through guides into a space in which there is a die.

As the metal is fed to the machine the die rises and falls, the

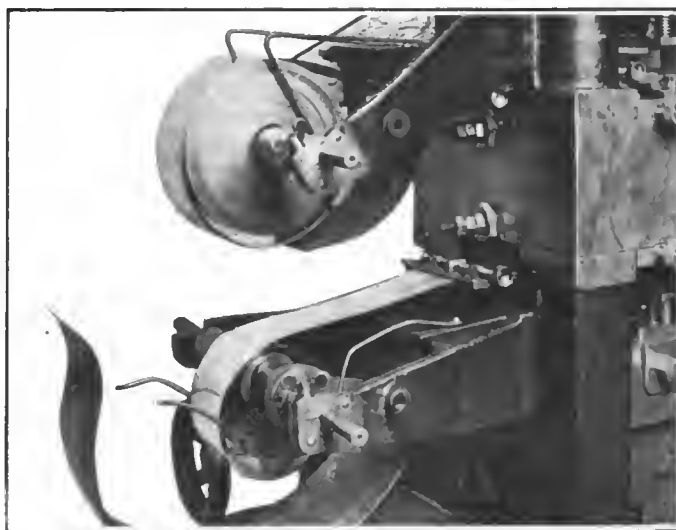

Stage 1—The raw material entering the crimping machine

die for the upper roll being entirely separate from that which operates the lower. The dies crimp the metal and corrugate the crimps, which are square in shape. After having passed the die the bronze is carried along in its corrugated form until it passes out of the first part of the machine into a guide which is so arranged as to bring the two strips together before they pass to the second series of operations, which is carried on by the same machine as contains the die. The strips having been brought together so that the upper and lower pieces fit into each other, with the square crimps in mesh, they are led into a block which contains the mechanism for firmly joining them together.

As the lower strip passes into the reach of the tool it is cut at the ends so that a flange is formed. It is for the purpose of forming this flange that the lower strip is wider than the upper. The next operation bends the flange up slightly. The other tools then turn it over and clamp it tight. The corrugations in the base of each of the crimps are arranged so that they are opposite to each other, thus leaving an open space between them for the easy circulation of the water. The two strips when fastened together form one of the tubes of the radiator. Another purpose of the small corrugations is to aid in the easy expansion and contraction of the metal without fear of damage to the fastenings of the tubes or of the bursting of the metal itself.



Stage 3—Cutting the clamped tubes to their proper length and placing them in a box of the correct width

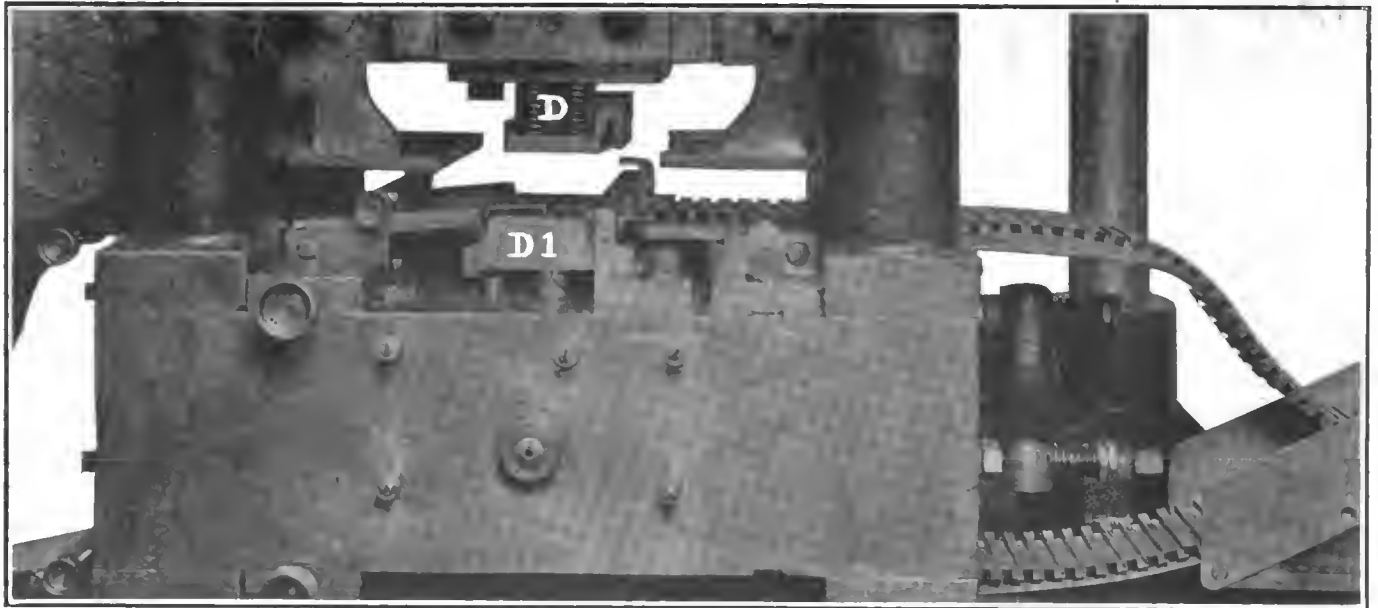

Stage 2—The strips of metal passing through the corrugating and crimping dies. The strips flow together as shown

After having been crimped, corrugated and joined together the two strips pass on as one tube to the next operation, which is to cut them into lengths as required for the particular radiator which is being made. The length to which each tube is cut is equal to the extreme depth of the radiator from top to bottom; that is, the tubes are all cut to the same length as the longest tube in the radiator. A tube which has been cut off forms a guide for the length of those cut, so that after each length is cut off it can be placed in the box which is made for the purpose of holding them as they are cut off.

The boxes are so constructed that they are just wide enough for each radiator, and after they are filled there is enough tubing in them to make the radiator required. When the tubes are put in the box they are watched to determine any inaccuracies which may have accidentally found their way into the cutting or machine work. These inaccuracies will be very easily determined by a variation of the straight line which should be formed by placing the tubes upon each other in the box. After the boxes are filled the first series of operations is finished and they are

transported from the machine room to the next stage in the work which consists in shaping the sections and soldering them.

When the box with the set of tubes arrives at the bench at which the work of shaping the radiators is carried out, the tubes are removed one by one and compared with the frame into which they are to fit. This will give the proper length of each tube, and it is cut accordingly. After having carried out the operation of cutting the tubes for a given type of radiator shape for a short time, the operator becomes so familiar with his work that he will know whether there should be a variation of one or two squares in the length of the succeeding tubes in order to secure the required shape. In the case of a radiator which is square, such as is used occasionally on trucks, there will be no cutting required.

After having been cut to the proper form the tubes are placed as they are to go into the radiator frame and set up on a slab from which project a series of pins. The tubes are set upon the slab, being held in their exact relative positions by the pins. A strip of brass tapered much in the form of a knife blade is then called into use for the purpose of opening the ends of the pipes which may have been closed by being passed through the various stages of the work. The top and bottom of each tube will have to be opened in this manner so that the water will enter into all of them equally in passing from the top of the radiator to the bottom. A full use of all the cooling space available will not be had unless these ends are properly opened.

When the tubes have been set upon the slab correctly and the ends of the tubes opened the section is ready to be soldered together. In order to do this as expeditiously as possible the pin frame is attached to a small electric traveling crane which runs along a beam above the table upon which the frame rests while the sections are being placed upon the pins. A single chain hangs from the crane, carrying a hook which may be seen by referring to stage 5. This hook engages with the chain which holds the frame. The frame chain is spread apart by a brace so as not to interfere with the free operation of the crane. When the work of opening the ends of the various tubes is completed the frame is lifted above the table by the crane and two men run it along the table, the whole frame traveling very easily since the wheels of the crane run freely on the track. When the end of the table is reached the framework with its section pinned to it is seized and given a turn so as to bring the frame in a reversed position; that is, with the section of tubes hanging down from the frame, as seen



Stage 4—Cutting the tubes to conform to shape of frame



Stage 7—Dipping the other side of the section into the solder

is shown in stage 6. The solder is carried in a molten condition in the flat pan seen just below the inverted frame. The illustration depicts one of the men in the act of manipulating the crane so as to bring the frame gently into the solder, which is kept in a liquid state by means of a gas flame beneath the trough.

A cooling slab stands close to the soldering trough, and may be seen in stage 6. The section is lifted from the solder and placed upon the slab, which, owing to the qualities of the metal, quickly robs the solder of its heat and allows it to harden in a very short space of time. When the solder has become hard the section is lifted from the frame and is ready to be soldered on the reverse side. This operation is shown in stage 7, where the wooden frame into which the section is clamped for this second dipping may be seen. As may be noticed, this operation is exactly the same as the first dipping, except that instead of using the crane to carry the heavy framework it is done by hand, as the section has been removed from the frame and is held together by the solder accumulated on the first dipping.

The next operation consists of brazing a  $\frac{3}{8}$ -inch strip of brass around the outer edges of the top and bottom of the tubes and at the same time running the solder well around the ends of the tubes. The solder used in this operation is string solder, which has been made by dipping a ladle into the trough containing the molten solder and pouring the solder on the cooling block. The ladle is arranged so that when tilted the solder will flow from five small holes about  $\frac{1}{2}$  inch apart. As the solder is poured the ladle is moved along horizontally so that when cooling the solder will have the appearance of a string. As the strips of solder cool they are pushed off the cooling slab into a basket and are used in this form, known as string solder.

After the strips are fastened and the tubes soldered tightly together the section is then turned over to the assembly department. The first process to which it is submitted here is one of cleaning. A scraper and file are employed to remove all the excess tin which may have accumulated during the various processes through which the product has passed from the time it was a piece of raw material. The section is mounted upon a bench, as is shown in stage 8, and filed clean on all sides. It will often be found that a bubble of solder will have formed across the face of one of the squares in the section. This is also removed during this stage of the work, along with all the other excess material.

The frame of the radiator has been in course of construction at the same time as the tubular sections. The sheet brass of which it is composed has been bent and cut to form and the ends soldered. Each make of car usually has some variation in the shape of the radiator, so that separate frame shapes

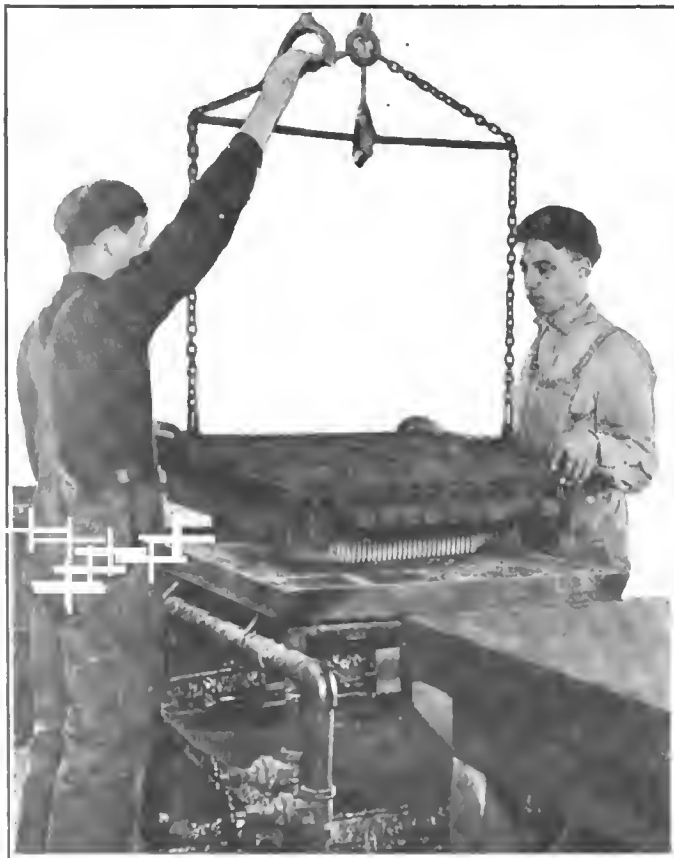

Stage 5—The cut tubes are placed in the frame F and held by pins P  
Stage 6—Soldering the ends of the section to hold the tubes together

in stage 6. The crane is then run along the track again until it is brought above a trough of zinc chloride, when the frame is lowered so that the outer face of the section will be immersed in the liquid. After this has been accomplished the section is ready to be dipped in the solder, which operation



Stage 10—Giving the final test for leaks in the finished radiator

are made for each car. The frame is then ready to be assembled with the section. This is accomplished by placing the section upon a horse, as seen in stage 9, and laying the frame over it. Any irregularities in shape are corrected and the frame is then finally slipped over the section and soldered carefully into place. The string solder is used in this operation and, as the strips are very thin, it is comparatively easy to reach all points.

The frame and the section together compose the radiator. The first step taken with the assembled radiator is to test it for leaks or defects. This is done by placing the radiator in a tank, as shown in stage 10. A supply of compressed air is available for this purpose, and this is led into the radiator. The outlet is corked up so that no air can escape and a pressure of 20 pounds is put on the radiator. If there are any leaks the air will escape in bubbles and indicate the position to the observer, who can then readily solder it at the required point. After the tests have been made and any leaks sealed the radiator is ready for the finishing touches, which consist for the most part of polishing and buffing processes.

The finishing polish is put on by hand and the radiators are then stacked up ready for handling by the delivery department. The handling of the radiator from start to finish is made as simple as possible by having the plant so arranged that one stage can follow another with as little interval between them as possible. There are no long pauses for parts to dry before the radiator can be touched, and there are no long distances through which parts have to be moved in the different stages of construction. They are all on the same floor and so arranged that the work starts from one end and gradually progresses through the shop until it is completed at the most convenient point for handling the finished product.

### Motor Wagons for Military Use

Consul General John L. Griffiths, London, England, is responsible for the statement that the British War Office has furnished particulars of a provisional scheme for the subsidizing of petrol motor lorries or wagons built after January 1, 1910, and owned by civilians. The vehicles will only be purchased in event of national emergency and will not be enrolled for hire purpose or for maneuvers. The War Department is to have the right to purchase on fixed terms any enrolled vehicle when the War Minister certifies in writing under his hand that the country is in a state of national danger or if a proclamation be issued under the reserve forces act of 1882.

The lorries which may be thus acquired are divided into two classes, (1) those capable of carrying a useful load of 3 tons (ton = 2,240 pounds) at 10 miles an hour, and (2) those capable of carrying a useful load of 30 hundredweight (hundredweight



Stage 9—Fitting the radiator frame to the section before soldering them together

Stage 8—Scraping the excess tin accumulated during the manufacture from the section before assembling

= 112 pounds) at 12 miles an hour. The wagons will be subsidized for two years, and the owners will receive an initial subsidy varying from \$39 to \$58 and an annual subsidy of \$73, payable half-yearly. A further \$48 will be paid if the wagons carry a second magneto.

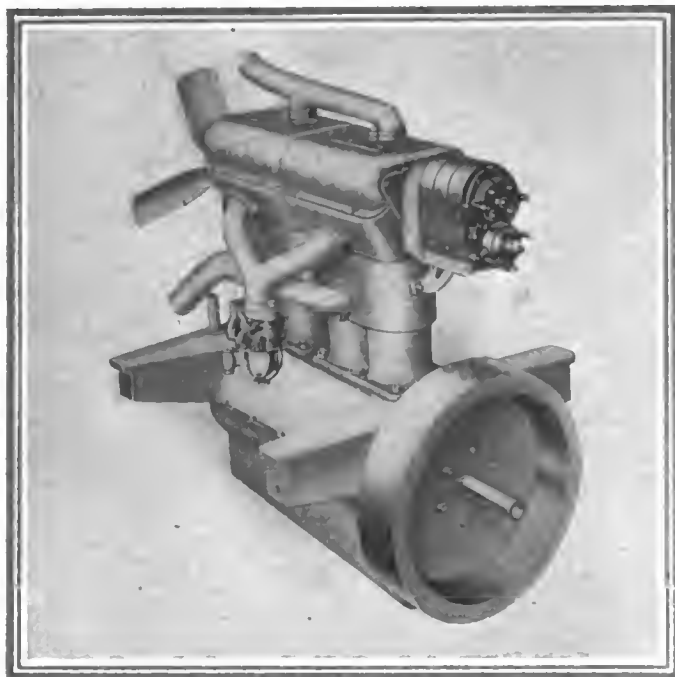

Fig. 1—External view of carbureter side of the R. C. Mitchell motor, showing simplicity of construction

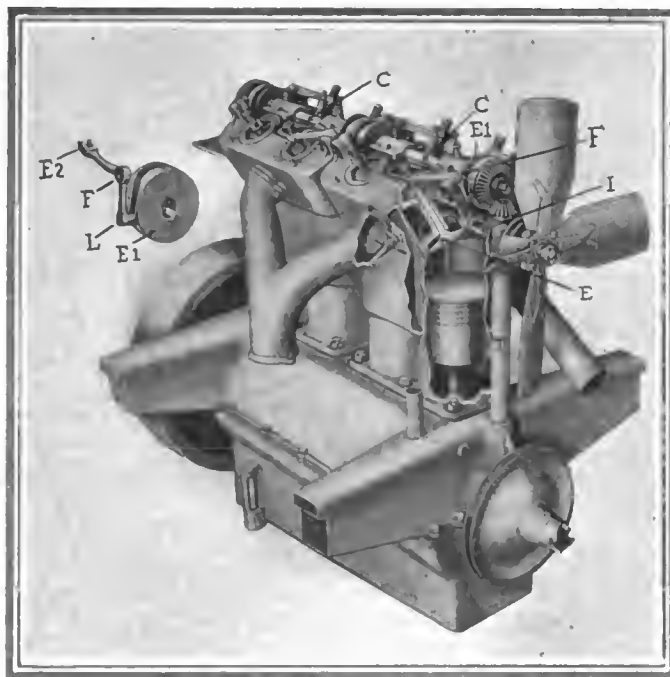

Fig. 2—Exhaust side of Mitchell motor, with part of casing removed to show the operation of the valves

## Explaining the Mitchell Motor

**A**N inspection of the motor shown in Figs. 1 and 2 will reveal a number of new features contained in this construction of engine. The Mitchell motor is of the four-cylinder, four-cycle type, and is characterized by the small number of parts constituting it. Fig. 1, which is an external view of the carburetor side of the motor, shows that all the delicate parts of the engine have been given a high location, the valves for admission and exhaust being arranged in the heads of the cylinders and driven from above by a camshaft stationed above the cylinders. As is seen in Fig. 1, the magneto has also been given a high-up location, with the obvious advantage of it being free from troubles that arise in fording a stream. The importance of this feature was fully recognized by the participants of the recent Glidden tour.

The cylinders are of gray iron and cast in pairs, with ample water jackets surrounding those portions which require cooling. The water piping has been made of liberal dimensions, and the cooling water, which is circulated by a centrifugal pump in the crankcase, enters the jacket on the inlet side, leaving it, after having played around the cylinders, through the pipes seen on the top of the jacket. The valves are in cages in the cylinder heads, and referring to Fig. 2 it is seen that the mushrooms, E of the inlet and I of the exhaust, as they seat form an obtuse angle. The valves are of large diameter so as to permit of rapid charging and scavenging, and are actuated from the overhead camshaft C through barred cams E1. The end of the link L of the valve stem lever slides in the cam slot, and the enlarged view of the cam in Fig. 2 illustrates the construction of this member. The lever is fulcrumed at F, so that the eccentric action of E1 during the rotation of the camshaft causes the end E2 of the valve lever to be reciprocated, thereby lifting and dropping the mushroom off and to its seat. The location and construction of the cams does away with the necessity of using heavy springs with a consequent loss of power. The cams close the valves as positively as they open them at all motor speeds.

The camshaft itself is driven at half engine speed from the

crankshaft by means of transmission rod T engaging crank and camshafts by means of bevel gears at both its ends; camshaft is equipped with wick oiling and reservoir containing enough lubricant to keep the shaft well oiled for a month. Each barrel cam operates one inlet and one exhaust valve, so that only four cams are required to operate the eight valves. The magneto is driven by a spur gear direct from the camshaft and at the same speed as this shaft. The location of the magneto keeps it beyond the range of dirt and grease, and the design of the motor is such that the magneto extends through the dash, being directly accessible for the driver if inspection is wanted.

As may be seen from Fig. 1, the carburetor and intake manifold are located at the left side of the motor, and the exhaust appliances are stationed on the other side of the engine. Beside the fact that this arrangement keeps the sides of the engine free of all accessories, save a sight-feed on the crankcase on the exhaust side, the peculiar arrangement of the magneto is accompanied by a saving in power required to drive it. The direct drive of the magneto off the camshaft does away with the friction loss otherwise encountered in the magneto half-time gear.

All working parts of the motors are fully encased, but the jacket is so bolted to the base chamber that eventual inspection may be had without difficulty. In the crankcase is located an oil pump, which lifts the oil from the base chamber, serving as a reservoir, to the cylinder bearings and connecting rods through small brass leads, affording a positive force-feed system.

The flywheel is of substantial dimension, with sufficient room in it to take in a clutch of the cone or disc type. It is located adjacent to the rear end of the crankcase casting, which has two pressed-steel drop arms on each side, permitting of suspending the motor on a chassis frame.

The initial motor constructed by the designer has 4 3-16 inches bore and a stroke of 5 inches. It is used on a seven-passenger touring car, and for nine months has given very satisfactory service. The inventor and designer of the motor is R. C. Mitchell, of Springfield, Ohio.



# The Long-Stroke Motor for Cars

## Part I.

BY PROFESSOR W. D. ENNIS.

THE practice of rating motors at standardized piston speeds may be justly criticised. All common rating formulas assume some fixed speed of piston. Thus the expression,

$$HP = \frac{nd^3}{4}$$

for the horsepower output of  $n$  four-cycle cylinders having each a diameter of  $d$  inches holds approximately, only for a piston speed of 1000 feet per minute. By this rule an ordinary automobile motor with four cylinders of 4-inch diameter would give 16 horsepower, no matter what its stroke. The length of stroke is immaterial because with a fixed piston speed the longer the stroke the fewer the number of revolutions per minute. For example, with a 6-inch stroke we should run at 1000 revolutions per minute, and with a 4-inch stroke at 1500. In each case the piston speed is 1000 feet per minute.

Short stroke means high rotative or crankshaft speed for a given piston speed. Assume the useful mileage of a certain car to be 100,000 miles, during which the travel of a point on one of its 34-inch tires will be

$$12 \text{ inches} \times 100,000 \times 5280 = 6,336,000,000 \text{ inches}$$

Since the circumference of the tire is  $34 \times 3.1416 = 106.5$  inches, the wheel will have made  $6,336,000,000 \div 106.5 = 59,400,000$  revolutions during the life of the car. If the average gear ratio between motor and rear wheels during this whole period has been 4, the motor will have made  $4 \times 59,400,000 = 237,600,000$  revolutions. If its stroke is 5 inches, its pistons will each have traveled

$$2 \times 5 \times 237,600,000 \times \frac{1}{12} = 198,000,000 \text{ feet}$$

or 37,550 miles. The same total piston travel would have been realized by a motor of 6-inch stroke while making 198,000,000 revolutions. For a given piston speed, or piston travel, the revolutions per minute of the motor will vary inversely as its stroke.

### Standardized Revolutions Per Minute

It is the number of revolutions per minute that should be standardized, rather than the piston speed. Shocks wear out machinery. Every time a crankshaft makes a revolution, the piston reverses its direction of movement twice. In each cylinder of the 5-inch stroke motor just referred to, there will have been 475,200,000 such reversals and shocks. By changing the stroke to 6 inches, the mileage and horsepower might be the same, while the number of shocks would be reduced 20 per cent., the piston speed remaining constant. Roughly speaking, then, the 6-inch motor should be in better condition than the 5-inch, after 100,000 miles of service. When piston speeds were standardized, it was because stroke lengths were not greatly variable. With new length of stroke, new piston speeds are permissible, and the standard of piston speed will be directly related to the length of stroke.

The long stroke increases the horsepower capacity of the

Should Wear Longer Than the Short-Stroke Type and Prove a Better Hill-Climber—It Requires a Re-designing of the Motor and Generally Raises the Center of Gravity of the Car—Little Extra Weight Need Be Added—The Cooling Problem Is Not Disturbed—A Plea to Standardize the Revolutions per Minute of the Crankshaft, Rather Than the Piston Speed in Estimating the Horsepower of the Motor—Many Practical Considerations.

motor. Motor output is roughly proportional to piston speed. With a fixed number of revolutions per minute, the longer the stroke the higher the piston speed and the greater the power output.

Long-stroke motors have greater pulling power. This may be proved in two ways. First: Horsepower output is determined by pulling power for "tractive force" and speed, jointly. Consider two cars, moving at the same speed, up two parallel hills

of different grades. One has a 5-inch motor, the other a 6-inch motor. Otherwise the cars are alike. The piston speeds being the same, the 6-inch motor will develop the greater horsepower by 20 per cent. This horsepower is exerted in propelling the car up the hill. The propelling or tractive force must be, then, 20 per cent. greater in the case of the 6-inch motor.

As a second proof, consider Fig. 1, which represents successive simplifications of the driving mechanism. In Part A the piston  $B$  moves in the cylinder  $A$ , its rod  $C$  being pinned to the gear  $E$  at  $D$ . This gear drives the larger gear  $F$  about the shaft  $G$ . The force exerted at the pin  $D$  by the rod turns the wheel  $G$  at rotative speed somewhat less than that of  $E$ . In Part B such force is represented by the arrow  $L$ , the wheel teeth are omitted, and the revolution of  $J$  on a roadway is assumed to be equivalent to the development of the traction or pulley force  $K$ . In Part C both wheels are shown on the same shaft. The ratio of their diameters must now be reversed in order that the peripheral or circumferential speed of the second wheel may be the same as in the first sketch. In Part D the wheels are replaced by the equivalent wheel spokes or levers  $Q$  and  $R$ . The length of  $Q$  is equal to half the diameter of the circle described by the pin  $D$  in Part A. The length of  $R$  is half the diameter of the large wheel  $F$ , and is independent of the stroke of the motor. This stroke is, however, equal to twice the length  $Q$ .

Then if a given force be developed by the explosion in the cylinder, regardless of length of stroke, we have, in Part D,  $P$  and  $R$  fixed,  $Q$  proportional to the motor stroke, and  $S$  depending on all three. By the principle of levers,

$$P \times Q = R \times S. \text{ Then } S = \frac{PQ}{R}$$

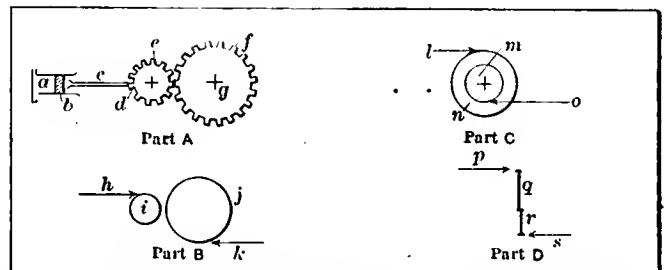

Fig. 1—Representing successive simplification of the driving mechanism of an automobile

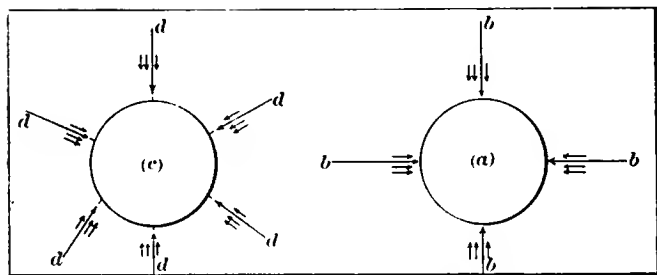

Fig. 2—Illustrating the comparative stresses in six-cylinder and four-cylinder motors

and is directly proportional to the stroke. And  $S$  is the tractive or pulling force exerted in propelling the car.

Increasing the number of cylinders does away with some of the advantages of the long-stroke motor. The total wear of the mechanism is dependent not only on the number of shocks but also on their intensity. At the moment when the piston is being reversed, at the head end of its power stroke, it undergoes the stress due to the pressure obtained in combustion. This pressure in pounds per square inch is independent of the length of the stroke. The total stress produced depends on the pressure and on the area of the piston. With six cylinders of the same aggregate piston area as four cylinders, the stresses in any one cylinder are only two-thirds as great as those in the four-cylinder motor. The condition of things is as suggested in Fig. 2. In the case of four cylinders, during two revolutions, each cylinder is fired once, giving the four severe stresses indicated by the arrows  $B, B, B, B$ , and reverses three times, giving the lighter stresses indicated by the short arrows. With six cylinders, there are six severe stresses and eighteen reversals, in two revolutions, but the former (indicated by the arrows  $D, D, D, D, D, D$ ) are less severe than those with four cylinders of the same capacity. The possible number of revolutions during the life of the car will therefore be increased because the shocks of reversal are decreased in intensity: and in this respect the use of six cylinders serves the same purpose as the use of a long stroke.

### Long-Stroke Motors Influence Design

The general use of long-stroke motors may seriously influence design standards. Fig. 3 shows that the over-all height of the motor includes the stroke, piston thickness and the clearance, which is proportional to the stroke, and the length of the connecting rod, also proportional to the stroke. If the connecting rod is twice the length of stroke, and the clearance height is half the stroke, then the head room necessary must exceed 3 1-2 times the length of the stroke, and a change of 2 inches in the latter will require 7 inches more head room. Obviously the overhead type of valve would with a motor of long stroke be undesirable. Again, the effect of increasing the stroke length may be to further increase the length of the connecting rod. Thus in Fig. 4, which is drawn to scale, we have a 4-inch piston,  $AB$ , with a stroke of 4 inches,  $BC$ , and 37 1-2 per cent. clearance,  $CD$ . Assume the connecting rod pin to be at  $E$  when the piston is down, and at  $F$  when the piston is up. If the clearance width of the rod is 1 inch, then the line  $G$ , drawn from  $F$  to just strike the inner bottom edge of the cylinder, represents the extreme of angularity of the connecting rod. If we place the shaft at the highest position possible, namely, at  $J$ , where the crank circle  $H$  (of diameter equal to the piston stroke) just strikes the rod pin  $E$ , we find that the most extreme swing of the connecting rod keeps within the clearance line  $G$ , and that the rod length may be as little as 4 inches, equal to the stroke. But in the 6-inch stroke motor, shown to the right, the same position for the shaft might be impracticable.

The long stroke means a new distribution of weights. If the shaft elevation is fixed, increasing the length of the stroke means a raising of the heavier parts of the usual type of motor, and unless some equivalent adjustment is made elsewhere in the op-

posite direction, the center of gravity of the whole car will be elevated. A higher center of gravity should not be contemplated if cars are to be safe under usual curve and speed conditions. In Fig. 5, if  $B$  is the center of gravity, and if  $AB$  represent the centrifugal force due to rounding the curve, which depends on the radius of the curve and the speed, and  $BC$  the weight of the car; then the line  $BD$  joining  $B$  with the intersection  $D$  of lines parallel to  $AB$  and  $BC$ , as shown, represents the resultant force acting on the car through its center of gravity. If this line  $BD$  passes outside the base of the car, the latter will overturn. As shown, the line in question strikes the ground at  $E$ , while the wheel rests on the ground at  $F$ , so that the machine is safe. But if the center of gravity were raised to  $G$ , then with the same weight and centrifugal force the direction of the resultant line  $GI$  shows that the car would be unstable. Power plant and body design may thus be seriously influenced by the adoption of the long stroke.

The details of cylinder design may be modified. At standardized piston speed both the amount of mixture supplied and the time available to supply it will depend upon the stroke, and the necessary valve areas will be unaltered. But if *rotative* speeds be standardized and piston speeds be made proportional to strokes, then the long-stroke motor will demand a more rapid supply of gas and all ports will be made larger. Since there are objections to increasing valve travel, either increased valve areas or multiplied valves will be necessary.

Cooling arrangements need not be greatly changed. The lengthening of the stroke gives a proportionate increase in power output. The amount of heat to be removed by water circulation will increase in about the same ratio as the power, and will therefore be directly proportional to the stroke. As the cylinder barrel length available for jacketing varies with the stroke, there is about the same amount of transmitting surface, considering the amount of heat to be carried off, in both types of cylinder. If the short stroke permits of overhead valves, however, the arrangement and effectiveness of jacketing may differ in the two motors.

The long-stroke cylinder affords, in proportion to its power capacity, more room for accessories on the side walls of the clearance space, and less room on the top, than the older type of motor. These available space conditions may easily lead to new standards in valve type, valve location and jacketing.

The reduction in friction and greater ease of lubrication sometimes claimed cannot yet be demonstrated. Following steam engine analogies, it is safe to say that in both of these important respects a slow running engine of long stroke surpasses one of short stroke and high speed. But in automobile practice, long strokes are apt to be associated with high speeds, the greater power output for a given size and weight being the main object in view: and if no greater expense in lost work by friction or cost of lubrication ensues, we shall still have ample ground for approving the novelty.

A similar consideration applies to the question of weights. A long-stroke motor weighs more because it is longer. But it gives more power. At equal rotative speeds, the long-stroke motor should weigh less, in proportion to its power output, than the one of short stroke. If comparisons of actual design, weights and rating fail to confirm this, it is because the long-stroke cylinders have not yet been rated at full piston speed. A speed of 1500 feet per minute is just as reasonable at 9-inch stroke as one of 1,000 feet per minute is at 6-inch stroke.

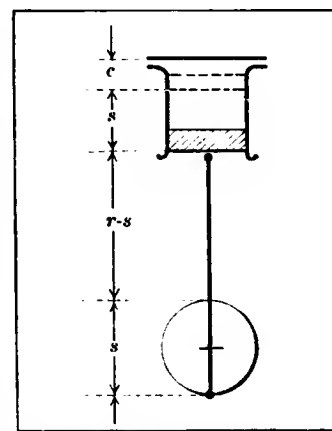

Fig. 3—Showing factors that must be considered in designing long-stroke motors

Relative weights of reciprocating parts are in favor of long strokes. The total pressures at reversal, represented by the arrows of Fig. 2, are less with long strokes, because piston diameters and areas are less for the same power. These total pressures determine dimensions of piston, rod, crank pin, crank and shaft.

Summary of the Results

Two schools of design are possible: With one present piston speeds may be regarded as the limit. Then the long-stroke motor will decrease the revolutions per minute, produce smoothness of running and lead to fewer breakdowns and longer life of plant. The power capacity will not be much increased, but the pulling force will be, and the cars will be able to negotiate steeper hills, though at low speeds. Valve areas will not necessarily increase. The motor weight will probably constitute an increased proportion of the whole weight of machine. Should the six-cylinder car prove especially more durable and smooth running than the four, then the long-stroke motor is not likely to monopolize the field with those who adhere to present piston speeds.

The other school of design standardizes rotative speeds. Long strokes then increase piston speeds and power output, while leading to about the same smoothness of running and length of life as in older designs. The pulling force will be no greater than that at lower piston speeds, but will be greater than in short stroke motors, regardless of piston speed. Large valve ports and passages will be necessary.

In either development, the long stroke properly applied necessitates re-designing throughout, particularly in order that the necessary head room may be obtained while keeping the center of gravity low. Valves will be kept at the sides of the cylinders rather than placed on top, and the type of valve used may be a modification from any now existing. Corresponding modifications in cooling arrangements will be necessary.

Reducing Time in Fire Fighting

For years the officials in charge of the fire departments of the large cities have been struggling with the problem of saving seconds. Everything possible toward that end has been done, the cost being given but little, if any, consideration. The wisdom of this course is apparent, the smallest fraction of time saved in the early stages of a fire being sufficient often to give the firemen that advantage which will prevent a small fire developing into a conflagration. Under the circumstances it is not to be wondered at that fire department officials of every city of considerable size are studying the possibilities of motor-driven apparatus, for in the single item of time saved the advantage of this latter-day method over the old horse-drawn proposition is almost beyond calculation. It is an actual fact, based upon figures gathered by officials of those cities which are fortunate enough to possess motor fire apparatus, that the time necessary to get to work at a fire has been reduced by more than one-half. This remarkable showing has attracted the attention of fire-fighters generally and is responsible in large measure for the demand from all sides for the early substitution of motor-driven apparatus for the antiquated horse-drawn machines, in the belief that the initial cost of installation of the former would be but a bagatelle when compared with the reduction of the annual fire losses following upon such a change.

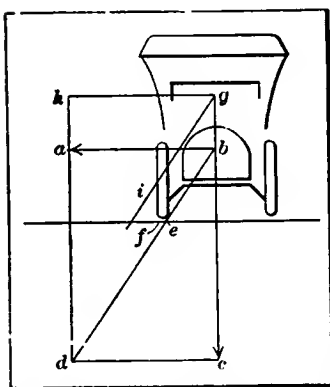

Fig. 5—Showing how length of the stroke raises the center of gravity of a car

Statistics of Italian Production

The value of the automobiles and automobile accessories exported from Turin, Italy, to the United States during 1910 was \$295,013, as against \$674,666 in 1909. Probably the year 1910 will hereafter appear as having marked a turn of the tide, and that European automobiles will in the future, on account of the formidable and increasing competition that they have met and must continue to meet from American automobile manufacturers, be exported to the United States in steadily decreasing numbers. The decrease can be explained in no other satisfactory way. It occurred in a year when the production of automobiles in the district of Turin and in Italy in general proved greater than ever before; when conditions in the district and throughout Italy were especially favorable to automobile builders; and when, for the first time, American automobiles and accessories entered Italian markets under markedly favorable conditions. The fact that the most important automobile-building company in Turin and Italy, and one of the most important in Europe, opened large works in the United States during the year had nothing to do with the decrease.

An estimate covering automobiles built in Turin during 1910 sets the number at 3,907, as against the estimate of 3,700 for 1909, and it is estimated that during 1910 only 560 automobiles were built in Italy outside of Piedmont.

Market conditions, on the whole, were good, and the demand for Turin automobiles, especially for cars of medium power, was satisfactory and uniform.

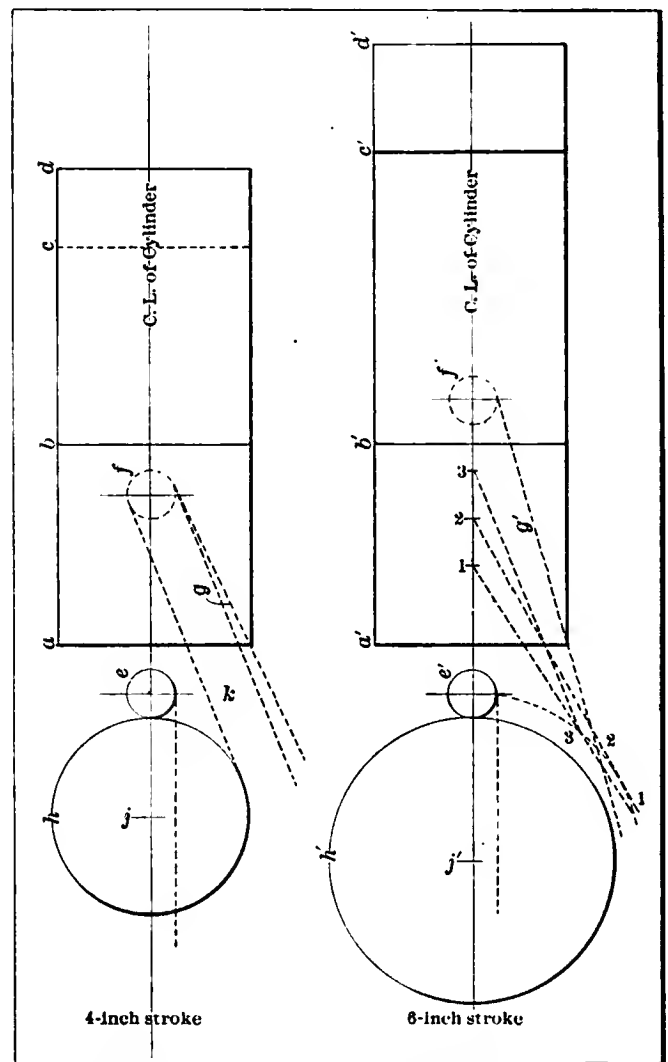

Fig. 4—Showing the clearance of connecting rods necessary in cylinders of different lengths

# Digest of the Leading Foreign Papers

**FEATURES OF RUTHARDT MAGNETO**—The Ruthardt magneto represents a comparatively recent German reconstruction and rearrangement of the mechanical elements of the high-tension magneto, resulting in a considerable weight reduction, which is of special interest to aviators, but involving at the same time the introduction of features which are considered as technical improvements relating to efficiency and reliability. The magnet is composed of a certain number of magnetic discs of the shape shown in Fig. 1. The armature turns directly between the poles, so that pole pieces are avoided as well as the screws needed for fastening them. The poles are polished so as to further reduce the space between them and the armature, and the magnetic field is thus utilized to the full. The armature is of the Siemens T type with two bobbins, one primary and one secondary, completely insulated from one another. The interrupter, Fig. 2, has no bearings and consequently requires no oil; wearing parts are avoided in it. The receiver consists of an insulated block D secured to the rotating disc of the breaker box by a screw I. A bent leaf spring A, provided with a platinum contact B, is secured to a boss K forming part of the mass. Screw C with a platinum point is adjustable in block D, and one of the edges, L, of the latter serves as a runway for the fiber roller E, which can turn, with considerable play, around the small spindle F, while retained laterally by a flat spring, not shown. The free end of spring A is bent back somewhat and rests against the roller with a tendency to press it outward, in which thrust it is aided by the centrifugality of the parts. The roller which travels on the interior cylindrical surface of rim N will therefore admit contact of B and C—short-circuiting the armature—except while it passes over the cam G on rim N, when the roller is pushed inward and forces the spring A outward and the platinum points apart. Two cams are provided on rim N if the magneto is used for a two, four or six-cylinder engine. The breaker box is adjustable around the armature shaft, so that the normal timing of the ignition may be varied. The screw bolt with hexagon head M which holds the box to the armature shaft conducts also the primary current to block D. A leaf spring, not shown in the drawing, impinges upon the head of M and its other extremity terminates in a threaded wire to which is screwed the binding post connecting with the interrupter mechanism.

An accessory of the Ruthardt magneto which may be applied to other magnetos as well is the device adopted for the automatic advancement of the spark, with increasing motor speed. It consists simply in a coupling collar formed of two metallic plates, Fig. 3, in which there are formed a number of depressions serving as beds for an equal number of steel balls and so curved that the balls under the effect of centrifugality will tend to roll from the central portion of each depression to the portion which

is nearer the periphery and more advanced in the direction of rotation. As the balls constitute the means by which rotation is transmitted from the driving plate to the driven plate in this coupling, it is understood that the driven plate is advanced in its relation to the driving plate when the balls take this more peripheral, and more advanced, position, and, as the driven plate is coupled to the armature shaft and the driving plate to the motor, it is seen that the object of advancing the spark by a device which forms no part of the magneto itself is accomplished. The description does not state by what means the two plates of the coupling are held in such a relation that the balls in seeking more peripheral positions are forced to overcome a small resistance, unvarying in amount.

The weight of the Ruthardt magneto is given as about 12 pounds for a 25-horsepower, 4-cylinder motor, reducible to 2 1-2 pounds in the type intended for a 4-horsepower motor bicycle. From description by F. Carles in *La Vie Automobile*, August 5.

**GERMAN CONSTRUCTION**—From observations of a general character on the trend of innovations in German automobiles, as these were shown at the recent international automobile exhibition in Berlin, it appears that great simplicity in lines and colors marks practically all automobiles intended for private use, but that, on the other hand, the public cabs exhibit schemes of decoration by which the builders have apparently aimed to meet the supposed vulgarian taste of the masses. Many of them look like movable feasts. Festoons of roses and violets or vines heavy with enormous bunches of full-ripe grapes wind themselves in painted counterfeit around the carriage work, and even encircle the driver's seat, and gold and silver plating in profusion seems to belie the statement that power cabs can be made to pay only by the strictest economy. The use of art etching on the window panes seems particularly superfluous in view of the fact that, whenever a window is broken by a "fare," there is invariably a quarrel about the amount of the damage to be paid.

Technically, it is noticed that in nearly all of the German automobiles at the exhibition the designers have gone to great lengths to reduce all noises to a minimum. Especially the valve movements have been the object of attention, and this is ascribed largely to the influence of the valvelcss motors and their success. In one of the Adler motors a cylindrical heel on the mushroom valve admits the use of cams which rise almost imperceptibly from their base circle, while in other cases the noise is not really removed but only muffled and localized by encasing the valve springs.

The oil ducts and force-feed oilers are now uniformly enclosed within the crankshaft casing, and the ducts to the individual bearings are frequently worked out as canalizations in the motor castings. As the perfecting of the oil feed has a considerable influence on the exhaust and on the formation of carbon deposits in the combustion chambers and in the grooves of the piston rings, many attempts have been made to so regulate the oil feed that surplus oil will escape combustion in the greatest possible degree, particularly under those trying circumstances when cars are forced to many stops or half-stops in close traffic and are likely to omit noxious odors in the exhaust.

Radiators are uniformly smaller than formerly, but much has been done to increase the air-cooling of the water-cooling system. Motors entirely cooled by air have, on the other hand, completely disappeared, even in the smallest cars.

The carbureters show a revolution. The noiseless double-jet type with auxiliary air inlet holds the field.

The magnetos, while reduced in size, develop strong sparks

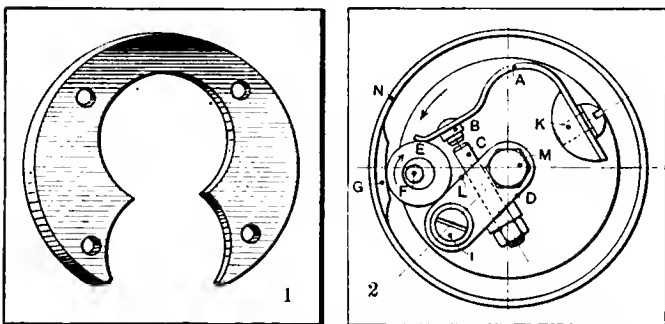

Fig. 1—One of the magnet disks of Ruthardt magneto—Fig. 2—Ruthardt interrupter mechanism

even at low rotary velocity of the shaft, so that starting of the vehicles has become much facilitated.

The valveless motor is represented not only by the Daimler companies of Stuttgart and Unterturckheim, but also by Loeb & Company, of Charlottenburg, and Stoewer Brothers, of Stettin.—From *Automobil-Betrieb*, October 1 and 15.

**THE WIRE MESH WINDSHIELD**—Trials have been made lately on the Brooklands track in England of windshields in which the customary glass surface is replaced by wire screening. Lightness, durability, low cost and safety in case of accident are not the only virtues claimed. They are supposed to afford better protection, on the following theory: The solid glass front constitutes an impenetrable barrier to the wind, and there is therefore formed a low-pressure atmospheric center behind it, causing the air to rush in from the sides in a disagreeably turbulent fashion. The wire screening, on the contrary, lets the air through while yet tempering its force, so that it does not strike the faces of the automobilists unpleasantly. When it rains the water sticks to the glass and bars the outlook, while it is driven through the wire web or runs down, finding but slight basis for adhesion in the thin strands.

Further information brings out, however, that wire screening was tried long ago for this purpose by Mr. Ferra, director of the astronomical observatory of French Indo-China. He found it good enough against wind and dust, but impracticable in a driving rain. The water stayed in the meshes and it was difficult to see through. Mr. Ferra's screening was quite close, the additional informant concedes, leaving openings which were only 1-2 millimeter square, and the possibility remains that the English improvement involves somewhat larger meshes and perhaps the use of a metal, for the wires, to which the water has a minimum of adhesion.—From *Automobil-Betrieb*, October 1 and 15.

**RULES FOR THE PRESERVATION OF METALLIC MACHINE PARTS** against rust were discussed and formulated with much detail at the last congress at Zurich by the International Association for the Testing of Materials. An elaborate report of the subject was prepared. The principal qualities which coatings for metallic pieces should possess are the following:

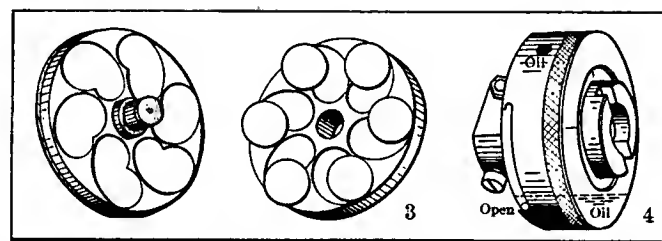

Fig. 3—Coupling plates with steel balls. Fig. 4—The complete coupling between armature shaft and motor, allowing automatic advancement of ignition by magnet

The coat should be thick; to this end the paint must contain as little as possible of volatile substances, excluding by this rule those having a turpentine base and colors derived from coal tar.

The coat must be at once elastic and hard, so as to resist well in the case of expansions and contractions and also against shocks and vibrations. These two conditions lead to products of a linseed oil base, which when dried form a soft elastic skin which in itself hardens very slowly but can be hardened by the admixture of metallic oxides.

The coat finally must be and remain continuous without shrinkage and cracking, which means that the paint must not be subject to decomposition.

The conclusions of the committee in charge of the subject are very precise. The colors to be used should be formed from sesquioxides of iron emulated in boiled linseed oil. The boiling of the oil should include a certain quantity of litharge or peroxide of manganese, giving a product of a minimum density of 0.93.

White or red lead or even graphite, if reduced to an impalpable powder, may be substituted for the iron oxide. These powders however must be in a state of purity and absolutely free from sulphur.—From *Le Génie Rural*, No. 37 (Sept.).

**A VIGOROUS IGNITION** always has a tendency to reduce the fuel consumption and to facilitate starting of the motor; therefore, it is often difficult to distinguish between an error relating to the adjustment of the carbureter and one relating to weakness or faulty timing of the spark.

## Harking Back a Decade

**I**TEMS appearing in the issue of *The Motor Review* under date of November 7, 1901:

The second annual automobile show being held this week at Madison Square Garden is easily the largest and most important event of its kind ever held in this country. Among the exhibitors are thirty-nine American manufacturing concerns, showing fifty-five gasoline cars; fifty-eight steamers and twenty-four electrics. Twenty different varieties of gasoline cars are on exhibition. Opening night drew an immense crowd of well-dressed automobile enthusiasts.

Great progress is to be noted in the development of the gasoline cars. The motors are still unstandardized and both single and double cylinders have their advocates while the question of upright or horizontal position for the cylinders is still a live issue. Tonneaus are to be seen on all kinds of cars and front end motor bonnets are quite common. Surface carbureters have lost favor. The magneto generator is coming into more general use. Transmission gears now have three forward speeds. A majority of the models shown are chain-driven but bevel gear drives are gradually creeping into use. Running gears are generally heavier.

The Winton Motor Carriage Company has announced an increase of its capitalization from \$200,000 to \$1,000,000, to be used in extending its manufacturing facilities.

Apperson Brothers have withdrawn from the Haynes-Apperson Company and have formed a new company to manufacture cars at Kokomo, Ind. The parent company made twelve cars in 1898 and since has largely increased its production.

The H. H. Franklin Manufacturing Company, of Syracuse, N. Y., will increase its capitalization from \$100,000 to \$250,000 and will manufacture a gasoline automobile which is said to contain several unusual features.

Exports of automobiles and automobile parts in September amounted to \$78,100, an increase in excess of \$22,000 over the figures for August. England took merchandise of this character valued at \$56,000.

Opinions are likely to differ as to the value of races and other exceptional public performances in advancing the motor vehicle in popular favor, but the attainment of high speed by some exceptional carriage is at best a doubtful benefit to the cause, especially when compared with some small improvement that tends to increase the utility or endurance of the vehicle.—*Editorial*.

R. M. Owen and four of his associates have incorporated the Western Automobile Company of Cleveland.

Emancipation Day will be celebrated in England next week to mark the fifth anniversary of the passage of a law allowing a speed of 12 miles an hour for automobiles.



# Letters Answered and Discussed

## Flow of Oil Must Be Watched

**EDITOR THE AUTOMOBILE:**  
 [2,900]—Please give advice on following subject. In filling crankcase of my automobile, which has splash system of oiling, I always spill some lubricant over outside of casting and often also my clothes. How can I get away from this abuse?  
 JOHN F. MURRAY,  
 Corsicana Junction, Tex.

A simple way of avoiding a dirty job is shown in Fig. 1. The upper half of the basechamber is shown, which has been tapped and a flanged filler attached to it. Flange and casting surface must be kept in tight relation by means of a gasket. At a somewhat lower point than the filler, the casting is tapped for a 1-inch pipe and an elbow is screwed into the opening, with the other arm standing erect. Into this arm is fitted a sight-feed, as shown in the illustration. If filler and sight-feed are well fitted, they communicate through the crankcase, and the level of the oil in the basechamber will be able to be read clearly on the sight-feed.

*The Editor invites subscribers to communicate their automobile troubles and personal experiences, stating them clearly on one side of the paper. If the nature of the case permits, send a sketch, even if it be rough, in order to assist to a clearer understanding. Each communication will receive attention in the order of its receipt, if the writer's signature and address accompany it as an evidence of good faith. If the writer objects to the publication of his name, he may add a nom de plume.*

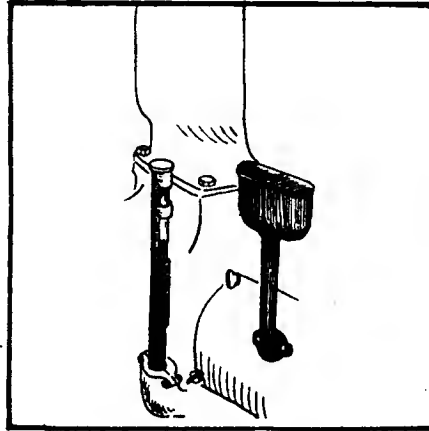

Fig. 1—Method of attaching a sight-feed and filler to the base chamber of a motor

## Acetylene Must Be Clean

**EDITOR THE AUTOMOBILE:**  
 [2,901]—My acetylene lighting system, which has always been in good working order, has failed to give satisfaction of late. My generator consumes much more carbide than it used to, and instead of improving the light derived from this source I find that the good qualities of the acetylene are being lost. The headlights burn with a comparatively dim flame and the glass of the lens rapidly covers up with water drops. Can you suggest remedy?  
 INTERESTED.

Darien, Ga.  
 Impurities are the cause of your trouble.

To radically cure the ill, it will first be necessary to clean the generator of the residues left in there of the old carbide charges. It's a ten-to-one shot that you have plenty of ashes in the generator, but this is a very poor state of things. Cleaning the generator will do away with most of the impurities, but those which spring from inferior carbide must still be considered. Acetylene produced from poor carbide frequently carries foreign matter with it, as well as vapor, which of course deprives the flame of its fine lighting quality. These two troubles may be obviated by interposing a trap in the gas line near the generator. As Fig. 3 shows, the pipes leading to the headlights pass through a vessel containing a trapping chamber, in which the

vapor or water drops traveling with the acetylene are precipitated. The draincock attached to the trap permits of emptying it when this becomes necessary. Another way of cleaning the acetylene on its way to the lights is to pass it through a vessel filled with moist sawdust or coke. A very clean gas will be obtained by this method of purifying it.

## Wants Jump Spark Ignition

**EDITOR THE AUTOMOBILE:**  
 [2,902]—Please give me some information as to the installation of a jump spark ignition system using a low-tension magneto and an auxiliary coil on the dash. I have had considerable trouble with the system which I am now using and am thinking of changing. Any help which you can give me will be appreciated.  
 C. J. D.

New York City.

The system of ignition which you mention is comparatively easy to install. Fig. 2 shows the method of wiring your car for it. The high tension secondary wires go to the spark plugs and one wire goes to the magneto distributor on the dash. The primary wires are run directly to the switch. Care should be taken to make good contacts and to trace all connections after being made. If you are not familiar with this line of work, we would suggest that you have the job done by an experienced repair man.

## Valve Spring Casings

**EDITOR THE AUTOMOBILE:**  
 [2,903]—Will you kindly illustrate in your columns some method of enclosing valve springs so as to keep out dirt?

Allentown, Pa. M. E. F.

One method of putting casings over valve springs is shown roughly by Fig. 4. However, this would apply only to valves which are in the cylinder heads. With the ordinary valve arrangement, casings, when used, are merely sleeves which are slipped over the valve springs and which rest on the spring seats. The casings here shown are bolted to the jacket heads and make a very tight and rigid construction. The use of these casings is becoming more and more general each year.

## Mechanical Oiler Adjustment

**EDITOR THE AUTOMOBILE:**  
 [2,904]—Will you kindly give me the following information? I have a splash system of lubrication installed on my automobile, but from what I hear I believe that force-feed systems are positively superior to that

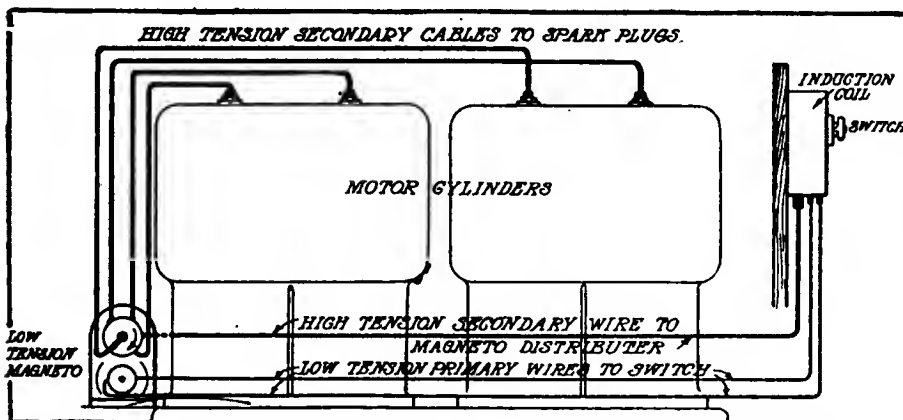

Fig. 2—Wiring system for ignition on a four-cylinder motor, using a low-tension magneto and an auxiliary coil

means of oiling. Therefore I would like to install a mechanical oiler on my car, especially since I understand that it is possible to regulate the amount of lubricant afforded to the various parts by this system. Will you explain in which way the flow of oil is lubricated?  
CONSTANT READER.

Bayonne, N. J.

There is usually some means of adjusting the length of the stroke of each plunger which forces oil out to its own particular part to be oiled, or of allowing a portion of the oil to flow back into the oil reservoir of the lubricator. Some have a sight-feed, other visible outlets to be used only temporarily during adjustment and wasting of the oil, so that they can be set for the required amount of oil for each movement of the pump plunger or other device for forcing the oil out. Start the engine and adjust for the required amount of oil. The feed device for each pipe should continue delivering the same amount of oil per stroke of its plunger or other device, whether the oil is thick or thin, hot or cold.

### Carbureter Pops Once More

Editor THE AUTOMOBILE:

[2,905]—I have observed that when I speed up my engine the carbureter infallibly begins to pop. Why is this? Also, how can this nuisance be done away with?

Newark, N. J.

S. M. G.

Popping in the carbureter, i. e., backfiring through the inlet pipe, may be due to a number of causes. A lean mixture may be the reason; in which case the engine should be given more gasoline, unless there is a leak in the inlet pipe or manifold, through which air is drawn and added to the mixture. An overheated cylinder or carbon deposits in the combustion chamber may cause preignition, permitting the flame to travel through open admission valve toward the carbureter. It may also be the fault of a weak inlet valve spring not strong enough to close the valve in time before the spark occurs in the cylinder; finally, a bent or dirty valve stem may be the cause of the evil. Remedies for all the troubles named are obvious.

### Misfiring Due to Several Causes

Editor THE AUTOMOBILE:

[2,906]—The cylinders on my car misfired not infrequently during the last week or so, and in order to locate the trouble I have looked over the spark plugs, but they seem to be in good shape. I am sure something is wrong, but I understand very little of the jump-spark system that is used on my car. The system includes a battery and trembler spark coil for each cylinder. Will you explain the situation to a

Louisville, Ky.

SUBSCRIBER.

Tests in the following order can be made until the trouble is found:

Switch on the reserve battery while still running.

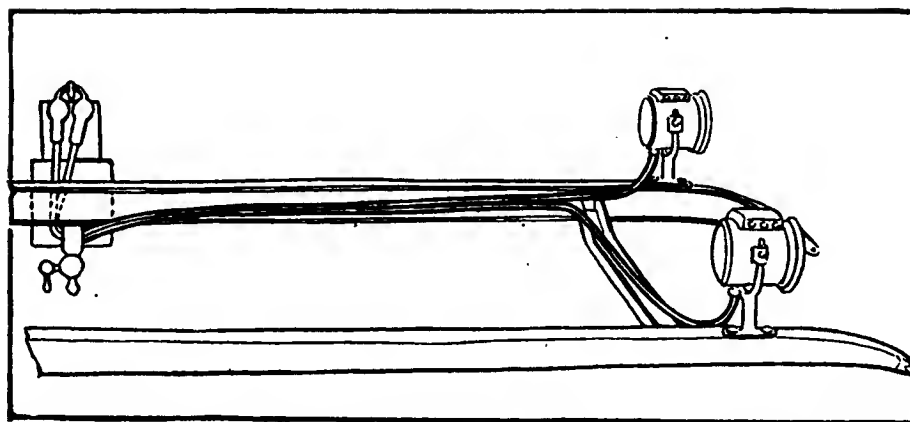

Fig. 3—How a trap may be interposed in the acetylene gas lead in order to catch water and mechanical impurities

Hold down the tremblers on the induction coils one at a time, or in pairs, to determine which cylinder misfires.

Stop the engine and crank slowly, noting whether each trembler vibrates strongly. If all vibrate weakly look for loose connections in the battery, the ground wires and the wire connecting the battery to the induction coil. Also examine for a broken wire inside the insulation of the same wires. Look for bare places on the wire between the battery and coils. See that the covering of the battery cells is not wet or worn off so that the zincs touch each other. Put in new low-tension wires.

If only one vibrator has weak action, clean the contact points, readjust its tension and examine the wire and connections be-

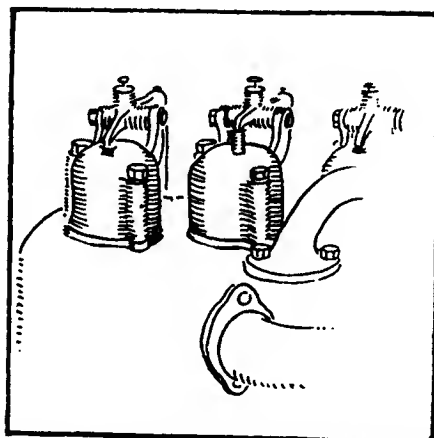

Fig. 4—Casings placed over the valve springs are efficacious in protecting them

tween it and the timer. Examine the timer, noting whether the contacts and spring for the weak trembler are in order.

If all tremblers vibrate strongly:

Remove the wire from the spark plug, hold its end about 1-4 inch from the engine casting, and close the circuit for that plug at the timer by turning the engine crank or placing a piece of metal so as to connect the timer terminal for that plug to the frame of the engine. The spark should jump the 1-4 inch gap. If not, look for poor insulation on the secondary wire.

If the spark coil has a visible safety spark

gap, sparking at this point, when the wire is disconnected from the corresponding plug and held well away from the metal of the car, will indicate that the spark coil is in good condition. The primary circuit must of course be closed.

Remove the spark plug, connect its wire to it, lay the bushing of the plug against the engine and close the primary circuit corresponding to the plug under test. Notice whether the spark is strong between the plug points. If not, clean the plug or replace it with another. Even though the spark is strong when the plug is removed from the cylinder, the current may pass through mica insulation or dirt and grease on the insulating material when the plug is in the engine, owing to the higher resistance of the spark gap in the compressed mixture.

Put in a new spark plug.

Interchange the high-tension wires. The misfiring will occur at the plug to which the defective wire is connected.

See also compression test, sticky valve stem, carbureter troubles, timer troubles, defective spark coil, etc.

### Old Clutch Comes Up

Editor THE AUTOMOBILE:

[2,907]—My clutch used to behave all right, but something seems to be at fault now. It is of the leather-faced cone type, and when I let it in gradually it suddenly seizes when a certain point has been reached. What is the matter? L. SMITH.

Stroudsburg, Pa.

Upon inspecting your clutch you will probably find the surface very dry. Put an ounce or two of castor or neat's foot oil on the cone, and distribute it carefully over the leather. This may be done by allowing one part of the clutch to slip over the other, then fastening the clutch open and thus letting it stand for about twelve hours. If the leather gets very oily some fuller's earth or chalk should be applied; it must be put on the clutch to absorb the surplus of oil. Sometimes it proves to be of advantage to clean the leather with gasoline before applying oil and chalk.

# Little Bits of Motor Wisdom

## Pertinent Pointers for Repairman and Driver

**FULL SUPPLY OF TONGS REQUIRED**—If the shop is to be equipped with a forge one of the requisites is a full set of tongs. The greatest point to remember in purchasing tongs is to have the handles of sufficient length from the pivot that there will be a good leverage in gripping a heavy article and that at the same time they will spring together close enough that the hand may grasp the ends of the tongs at the same time.

The tongs are made of various shapes, as seen in Fig. 1, so that they are adapted to the lifting of articles of different shapes and sizes. There are a number of uses to which these tongs may be put in governing the metal while it is in the fire, such as turning it over, raking the fire itself and performing the various little operations which will be found necessary in heating the work to the required temperature.

While at first sight it would seem that a full outfit of these tongs would be far from necessary, this is not the case if work is to be carried out on an extensive scale, for it is obviously impossible to pick up and throw a rivet with the same tool that is best in governing a piece of sheet metal. The uses of the other tools will suggest themselves by an examination of their shape.

The usefulness of these instruments, as of most other things about a shop, depends

to a large extent upon the way in which they are kept. By this is meant not so much the deterioration of the metal as the arrangement of the tools themselves, although the upkeep of the instruments is a matter which will require some attention. The tongs should be placed in racks or suspended close to the forge, and in a light place, so that they may be readily seen. That is to say, they should be kept on the same side of the fire as that on which the operator stands while working, for it will

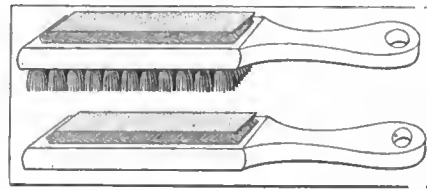

Fig. 2—File card and brush for cleaning files are truly necessary

be noticed that it is nearly impossible to see across a fire with any clearness. If they are placed in a rack they should be so arranged that they may be removed without great delay, as circumstances may arise that will demand hasty action on the part of the man who is performing the work.

The ends of the tongs will have to be occasionally cleaned so that the gripping qualities will not be impaired by the scale

which forms on the parts subjected to the intense heat of the flames. This cleaning is done by means of files after the metal is cool. The filed parts are then dipped in kerosene and heated. Exceptional care, however, does not have to be devoted to the tools which are used in a forge shop, as they are all more or less of the heavy and rough variety.

**CLEANING FILES**—Nothing will choke up so readily as a file, and when this is the case the tool is almost absolutely useless because the small particles wedge between the teeth of the file and gradually fill this space up so that in time where the choking process has been going on for an extended period the file will be reduced to little more than a flat piece of metal with occasional minute projections. Long before the file reaches this stage of inefficiency it should be cleaned, as shown in Fig. 3. The brush used for the purpose is seen in Fig. 2 and consists of either two parts or of one only. When composed of two parts there are two different types of brush, one being called a file card, while the other is known as a brush.

The files should be placed in kerosene to soak for a length of time, say over night, before the cleaning is attempted. The file brush and card is then called into use and the file scrubbed by running the brush vigorously along the file in a direction parallel with the teeth so that in this manner the wire bristles will dig the accumulated matter from the center of the groove between the teeth and clean it thoroughly. The file may be dipped from time to time in kerosene while the cleaning process is being carried out in order that the dirt may be kept soft enough for the brush to take effect. When dipping the file into the kerosene it may be shaken about so that the accumulated small particles will be well washed from the surface of the file.

Acid should never under any circumstances be used on a file to clean copper or other accumulated matter from the file. It is very true that the acid will attack the copper and cut it away from the file by combining with it chemically; still at the same time the acid will also affect the file and do it considerable damage if it is left in contact with it for any length of time.

The file card and brush is an inexpensive tool which may be purchased at a very small price from any hardware establishment. It will repay the expenditure incurred in its purchase by increasing the life of the file

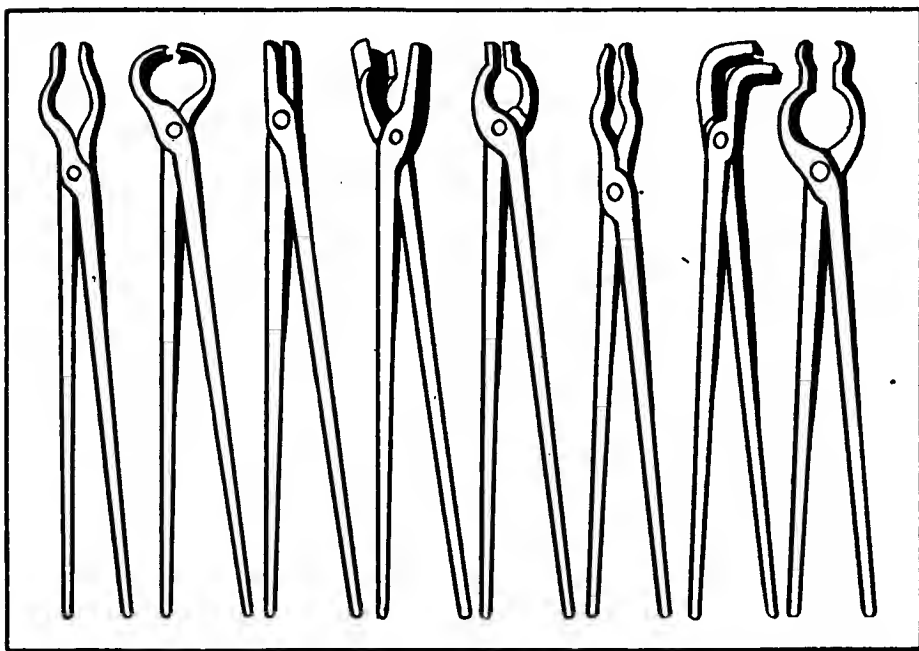

Fig. 1—Every pair of tongs in the repair shop has a purpose of its own

and shortening the necessary time of the operations performed with these tools owing to the better cutting qualities of the tool when clean and sharp. The use of a little elbow grease will probably be required to clean the file thoroughly, but it will be amply repaid by the results obtained and the trouble saved by its use.

The item of time saved is often overlooked in small shop practice; but minutes saved, when added together, go a long way toward keeping down the expenses. Time is figured very accurately in dollars and cents in the larger concerns, and there is no reason why it should not be as carefully watched in the smaller shops; for although it does not amount to as large an item by itself, it is still the same relative part of the whole.

**FORGE IS OF USE**—The portable forge is an instrument which is of considerable use about the garage if it is fitted up to carry out repairs of a more complicated nature. There will be many cases where the parts to be repaired will require heating. When the parts to be thus treated are of sufficient size to be heated in the forge, that is, when the other and smaller means are not available to heat the part to the required temperature owing to its thickness, the forge will be a necessary purchase unless all the work is to be sent out.

The city man's garage will hardly be fitted with a forge if he is a private owner of a car, but if repair work is done on an extensive scale, as in a professional shop where outside work is carried on, it will of course be a necessity. A place where the forge will also be of use not only for automobile repairs but also for a variety of other work will be upon a farm or at a country home where a hired man or several, according to the size and equipment of the place, carry on all the work to be done on all the details of the establishment.

In the installation of the forge it must be remembered that various noxious fumes will be given forth while the work is being carried on. The forge should, therefore, be placed near the door in such a way that the heated gases given off by the more or less volatile fuel used are safely led outdoors instead of remaining within the building to produce severe headaches and other unpleasantnesses for the workmen who are engaged within the building. The piping should also be short so as to reduce the cost of installation as well as the trouble and expense of the upkeep of a more extensive ventilation system.

Another reason which would almost be sufficient in itself to determine the position of the forge in the building, especially if it be placed within the basement of the shop, as is generally the case with the forge, is the fact that it will be used in Summer as well as in Winter. The forge, owing to the high temperature at which it is worked,

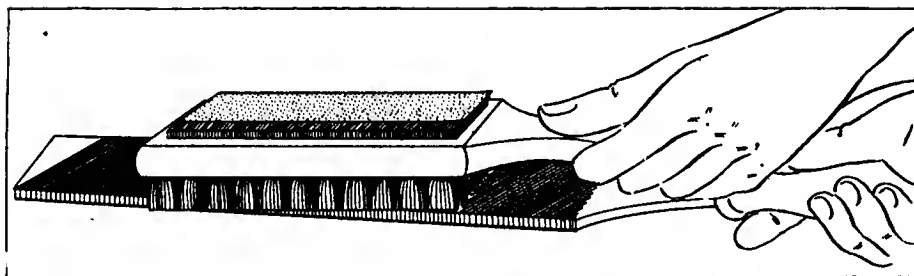

Fig. 3—After the file has been soaked in kerosene the brush is applied

will give off a tremendous amount of heat to the surrounding air in spite of the most elaborate precautions to exhaust as rapidly as possible the gases given forth. It is well to install a good blower fan in the draught line to expel all the vapors from the shop as speedily as possible in order to keep it cool in the Summer season as well as to keep the air as pure as is possible while working with the forge.

If a trap-door is convenient it would be well to have the forge placed directly at the foot of the stairs leading down therefrom, as in this way the problem of leading the piping out of the basement becomes very simple, since there are no bends in the piping and hence nothing to check the freedom of the passage of the gases from the building. If there is a lathe in the shop it would be well to have a forge with such an arrangement that the belting can be at-

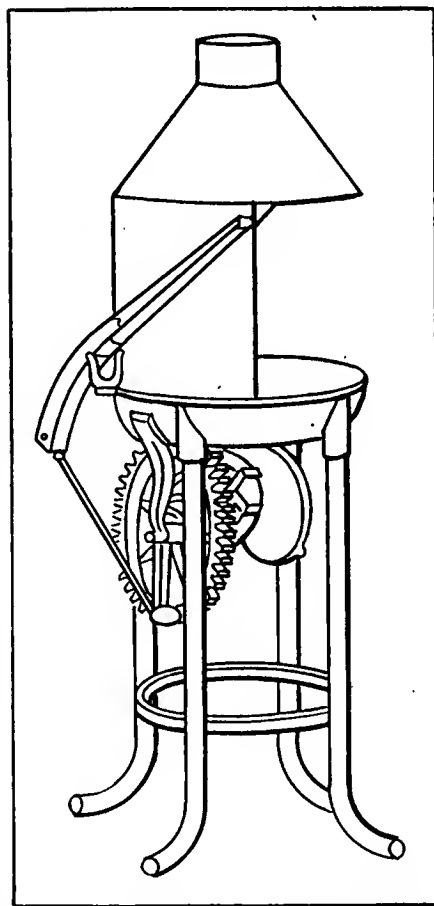

Fig. 4—A portable forge of the hand variety is equally useful in a shop and country garage

tached to the fan; but if the hand variety must be installed, the type shown in Fig. 4 with the semi-hood is a good one to use.

**WEAK MIXTURE CAUSED BY LEAKS.**—Backfiring into the intake will often be caused by a weak mixture and the carbureter will be blamed for the mischief, while in reality it is caused by a leaky intake manifold connection. This may be repaired in various ways, depending upon the method by which the manifold is connected to the cylinder. In case of a dog held by a stud bolt it may be that the dog has been sprung on account of too severe a strain having been placed upon it. Another cause of leakage where the manifold is held by means of a dog is that the gasket needs replacing. In this case it is necessary to carefully remove every part of the old gasket before replacing it with a new one, as it will be found that portions of the old gasket are very apt to adhere to the metal.

After having removed the old gasket the flanges should be filed bright so that there will be no chance of leakage on account of a burr being on the edge of the metal.

Where the manifold is held by means of a bolted flange the leakage is generally due to a defective gasket which is replaced in the same manner as the gasket in the case of a dog-fastened connection.

**CARE IN GRINDING VALVES**—It will very often happen that the emery used in grinding valves will fall into the cylinders if great care is not used to prevent such an occurrence. A preventative in the way of a piece of cotton waste placed in the cylinder port must always be used. In order that it will be a simple matter to withdraw the waste, a piece of string is turned about it before it is put into position. The loose end of the string is then carried out so that when the operation of grinding the valves is completed, it is only necessary to pull the string to remove the waste.

If the emery were to fall into the cylinder the damage which it would cause is almost immeasurable, as it would not only cut the cylinder and piston rings but it would also be very apt to get into the connecting rod and main bearings as well and destroy them.

# My Ideal 1912 Automobile

## Readers' Conceptions of What Next Year's Car Should Be

### Wants His Money's Worth

EDITOR THE AUTOMOBILE:

The following is my ideal car for next year: The motor to be used on the five-passenger car will give full 40 horsepower, with a reserve sufficient to meet any emergency. The cylinders are made of close-grained iron and are cast separately for accessibility, while the heads are machined inside to obtain better scavenging and to insure equal compression. The bore is 5 inches and the stroke 5 1-2 inches, not larger, as excessive side pressure of the piston on the cylinder walls would be caused by the large offset used in this motor, and also because an excessively long stroke will neither allow throttling down to very low speed on high gear nor give as good torque at this speed.

The pistons are light and have their heads convex, which gives rigidity, reduces expansion and prevents the collection of oil. The piston pins are held stationary with the pistons to prevent their working loose and damaging the cylinder walls. The drop-forged crankshaft has three bearings of at least 5 inches surface each, and are of the best white brass. Being offset from the center of the cylinders, the surfaces of pistons and cylinders are relieved of much side pressure and, therefore wear, while the power efficiency at low speeds is increased. The flywheel is bolted to the rear of the crankshaft.

The camshaft, also drop-forged, with integral cams, runs on three large annular ball bearings, and is removable through front or crankcase without disturbing the motor's adjustment. The valves are all on the right side, and, like the ports, are very large to permit the free removal of all gases. The valve push rods are light and adjustable and, as they raise the valves direct, side thrust and noise are eliminated. They also are covered to keep out the grit. The manifold has easy bends and is of the ejector type, thus avoiding back pressure and increasing the motor efficiency.

The crankcase is constructed with three drop arms, giving a power plant of the three-point suspension type on an underslung frame. The right side of the case contains the main opening. The flywheel, heavy spring motor starter and disc clutch are all enclosed within rear of case, forming a unit-type power plant which, combined with the three-point suspension, overcomes the destructive effects of jolting, raking and the usual tendency to wear and to work out of alignment. The bottom of the crankcase is to contain the oil

reservoir, and the oil pump is to be in an accessible place at the rear of the case, being operated from the camshaft by spiral gears. A sight-feed glass is to be on the dash to show that the pump is working. This system of lubrication is automatic, self-contained and requires no adjustment. A gauge is placed under the hood to show at a glance the amount of oil in the reservoir. The spiral-cut timing gears are to run in an oil-tight compartment of the crankcase and are to be so arranged as to be easily removed from the front.

The radiator is of the full honeycomb type and is flexibly suspended just behind the front axle. Water circulation is maintained by a large motor-driven centrifugal pump, with the magneto and cast aluminum fan driven by the same shaft on the left side of the motor. Dual ignition is to be had by one set of plugs over the inlet valves.

The clutch, which is mounted on large annular ball bearings, consists of thirty-three hardened and ground discs of saw-blade steel, and occupies the entire inner diameter of the flywheel.

Back of the clutch, but also housed in a bath of oil, is the automatic self-winding spring motor starter, which turns the motor over several times when a small pedal is pressed. The transmission, of selective type, providing three speeds forward and a reverse, with direct drive on third, is combined with the worm drive in unit with the rear axle, thus attaining simplicity and compactness as well as proper distribution of weight, which means safety and easy riding qualities, and, in combination with the disc clutch, tire economy. The housing of the gearset is of cast aluminum and is bolted direct to the pressed steel differential case. The high gear has four dogs, instead of many teeth, thus saving the danger of stripping. The shafts are mounted on adjustable roller bearings, and chrome nickel and vanadium steels are used here, as in other parts of the car.

The steering gear, mounted on the right side of the car, is strictly irreversible, with all its parts large. The worm and sector are both of chrome nickel steel, hardened and annealed, with an adjustment for wear. They are contained in an aluminum oil-tight case.

The cross-link of the steering gear is thoroughly protected, while a Caster type front axle is used for its many advantages. It is of the I-beam type and is drop-forged. The rear axle is of the full floating type, this being the most accessible and

only mechanically perfect axle made. The brakes are of very large surface and, as both sets are of the expanding type, one set of drums is used, giving a neat appearance and keeping out the dirt. The brake rods, which are fitted with equalizers, are within the frame and are easily adjusted by large wing nuts.

The frame is made of deep channel section cold-pressed nickel steel, heat-treated, narrowed in front for short turning and has a very deep and wide middle section, which tapers towards the ends. It is of the underslung type. This system affords great safety in turning, as the springs are so nearly in line with the horizontal center of mass of the car that, instead of being vertically deflected, the load is applied to the side of the springs and, as the springs cannot be laterally deflected, the frame and car retain a horizontal position. The low center of gravity not only makes the straight-line drive possible (which economizes power, only one universal joint being used), but also tends to prevent skidding and turning over. The wheelbase is 132 inches for the five-passenger car, and 142 inches for the seven-passenger. The wheels are of best second growth hickory, with twelve spokes both front and rear. They are equipped with Dorian demountable rims and take 41 x 4 1-2-inch tires.

The gasoline tank is at the rear of the chassis frame and has a capacity of 25 gallons. This tank is constructed of heavy, double-riveted copper, divided by swash plates. It has a large filling cap and also a gauge. The gasoline is forced to the carbureter by air pressure automatically supplied by the motor. The tank being in this position reduces the danger of explosion or fire, and it is filled more easily and without disturbing the passengers.

The springs are long and wide with thin leaves. They are semi-elliptic, front 42 inches, rear 56 inches, and are built under the Pike patent.

The body—deep, low and roomy—is of the straight-line type. Ease and grace are combined. The aluminum footboards, front and rear, are long and sloping to match the deep tilt given the seats. Under the rear footboards are the tool boxes. The running boards are also made of aluminum, and the large hooded dash is fitted with force ventilators to make the use of the fore-doors comfortable. Just above these ventilators, and also built in the dash, are the side lights. The doors are opened electrically by pushing a button on their tops, the horn and lights being operated in a



similar manner. The current for these accessories is obtained from a large storage battery located under the front seat. The fenders closely follow the curve of the wheels and, like the hood, are constructed of very heavy enameled steel.

The price of the five-passenger car is \$2,000.

The seven-passenger car has a double-drop, overslung frame, platform springs and six-cylinder, 60-horsepower Knight motor, but otherwise it follows the construction of the five-passenger car. The price is \$3,000.

A full equipment is put on every car, absolutely no allowance being made if any part of it is not wanted.

WARREN B. MOULTON.

Riverside, Cal.

### A 12-Year-Old's Ideal

Editor THE AUTOMOBILE:

I think most people will agree with me in regard to the following specifications which I have set down here for the ideal 1912 car:

The horsepower should be 35 to 40, which gives good power and low consumption of gasoline. The bore should be 4 1-2 inches and the stroke 5 inches, with four cylinders, cast in pairs, which gives the full rating mentioned above. The wheelbase should be 120 inches, giving enough room without making the car too heavy. The car should be shaft-driven, as that is more noiseless than chain drive. There should be three speeds with direct drive on third, geared 3 1-2 to 1. The clutch should be an asbestos fabric-covered cone clutch. The weight should be about 2,800 pounds, and I would use 35 x 4 1-2-inch tires that would give good mileage without being too large. The springs should be elliptic on the rear and semi-elliptic on the front.

I would have a double high-tension magneto system with two sets of spark plugs. The oiling system should be an automatic force-feed through a hollow crankshaft, throwing off oil and lubricating the walls of the cylinder, the camshafts, etc. The brakes should be 17 inches in diameter with a 2 1-2-inch face mounted on the rear axle hubs. The spark and gas levers should be mounted on the steering wheel on the outside, with a foot accelerator on the floor. The rear axle should be of the full floating type and the front axle a forged steel I-section.

The car should be fully equipped with top and windshield, and the cost about \$3,000.

ALLEN ADDICKS.

Philadelphia.

### \$2000 for a Real Car

Editor THE AUTOMOBILE:

I cannot resist the temptation to give my idea of what a pleasure car should be for 1912 or for any other year. My ideal car

would have 130-inch wheelbase. The wheels would be 36 inches in diameter with wire spokes, as the wire wheel is both stronger and more resilient. The tires would be 36 x 4, on demountable rims. Both front and rear axles would be I-beam construction, and the frame would be of channel section, double-dropped and inset at the forward end.

The motor would have six cylinders, cast three together and having seven roller bearings on the crankshaft. The bore would be 4 inches and the stroke 6 inches, and the motor would have the Knight sleeve-valve system. The lubrication would be positive by pump through the crankshaft and cylinder walls. Cooling would be by means of a honeycomb radiator mounted over the front axle and by a rotary pump. The radiator would have a screen fitted in front of it.

The transmission would have three speeds forward and reverse, with a bronze and steel disc clutch, and a thrust block of roller pattern to take up the thrust.

The body would be of aluminum and wood, five-passenger, fore-door, of simple panel design with the drive on the right side. The rear seat would be forward of the rear axle, and the front springs would be semi-elliptic and rear springs full-elliptic, as in the Mercedes. Final drive should be by side chains enclosed in oil-tight cases. This drive is absolutely noiseless and most efficient.

Finally, this car should be built of the very best materials with the best of workmanship, and sold for \$2,000 by a real manufacturer. A financier would want \$4,500 for it.

E. R. C.

Buffalo, N. Y.

### Wants Knight Motor

Editor THE AUTOMOBILE:

My idea of an ideal all-around car is one with Silent-Knight motor of six cylinders, 3 1-2-inch bore and 5-inch stroke. The wheelbase should be 124 inches, tread 56 inches and the wheels should have 12 spokes all around with demountable rims and 36 x 4 1-2-inch tires.

The emergency and foot brake should be on rear wheels, external expanding inside drum for emergency and outside drum for foot brake, 15 inches in diameter, 3 inches wide, with drum bolted to each spoke. The gearset should have four speeds and reverse mounted on annular ball bearings. Gears and shafts of nickel steel.

I would specify shaft drive inclosed in torsion tube with one universal joint, drive shaft, pinion and bevel gears nickel steel. rear axle full floating ball bearing of nickel steel, front axle and steering knuckles also nickel steel. Steering should be by irreversible worm and gear, arm and all connecting rods alloy steel of ample dimensions; this is one of the most important parts of the car and should be extra strong. Springs semi-elliptic in front,

three-quarter elliptic on rear, of vanadium steel.

The carburetor should be double-jet, hot-water jacketed, controlled by hand throttle on steering wheel and foot accelerator. Ignition should be by high-tension magneto, lubrication force feed and splash system. The clutch should be a multiple disc, running in oil.

The body should have fore-doors, top, windshield, electric lights. Klaxon horn, trunk rack, tire irons, speedometer, coat and foot rails. Gasoline tank should be hung from frame on rear with pressure feed to carburetor, frame pressed steel heat treated, right-hand drive steering wheel 18 inches in diameter and set low enough to be convenient. There should be about 10 inches clearance.

H. A. TIBBETTS.

Alton, N. H.

### \$1250, If Quantity-Produced

Editor THE AUTOMOBILE:

The motor of my ideal car would have four cylinders of 4 1-4-inch bore and 4 3-4-inch stroke. The cylinders should be cast in pairs, allowing a three-bearing crankshaft, and the valves should be of the poppet type, extra large, enclosed, and all on the same side of the motor. The crankshaft should be offset 1 inch. The splash system of lubrication should be used, and means should be taken to prevent the oil from running to one end of the crankcase when ascending or descending a hill. I prefer a Splitdorf magneto, and a carburetor which is water-jacketed.

I should prefer the clutch and emergency brake to be operated by a pedal to the left, with a locking device, and the service brake by a pedal to the right. This method of control would be superior, I think, to that suggested by the correspondent who wants the clutch and service brake operated by the same pedal, in that it would allow the service brake to be applied without releasing the clutch when descending a steep hill with the throttle closed and the engine acting as a brake. Either method, however, is good, since it dispenses with the hand lever, which is a nuisance in a fore-door car. The gear shift lever should be low enough to permit easy access to the driver's seat from the right-hand side of the car.

The wheelbase should be about 112 inches, and the body hung low to add to the beauty and riding qualities of the car. I should prefer 34 x 4 quick detachable tires, with an engine-driven air pump for easy inflation. A clear vision windshield would make driving more of a pleasure. A B. and L. Castor front axle would add to the ease of driving and the safety of the occupants of the car.

If this car could be produced in quantity, I fail to see why the price should be more than \$1,250, including top, windshield, electric lights and self-starter.

Lancaster, O.

E. R. B.

## Details of the G. & A. Carbureter

WHILE the desirability of a perfectly automatic carbureter is hardly to be denied, practice has not proved the possibility thereof until this day, and designers have resorted to the construction of semi-automatic working carbureters, *i.e.*, those in which either gasoline or air intake is fixed.

Since internal combustion practice has shown that a motor is much more sensitive in regard to a variation in the quantity of the fuel rather than to an altered amount of oxygen, there seems to be an advantage in the application of a stationary gasoline nozzle. The great army of automobilists are only too apt, in case of a slight disturbance of the working organs of the motor, to try to remedy the trouble by changing the carbureter adjustment, which in nine cases out of ten is innocent of the trouble laid at its door. For this great number of motorists the use of an unalterable gasoline adjustment which serves for a wide range of speeds must be considered a blessing. Thus after deciding on the correct construction of the gasoline supply and nozzle it remains to so design the air-supplying members that they lend themselves as perfectly as possible to the varying demand of the motor for mixture.

In the G. & A. carbureter, a full view of which is seen in Fig. 1, the gasoline on its way to the engine flows through a float chamber, where its maximum level is slightly above the nozzle outlet, which is placed in the plane where the upper widening of the Venturi tube sets in. In Fig. 2, depicting the float chamber in section, the manner of its operation is shown. The top of the chamber is flanged to permit of fixing the cover thereto, and under the cover, in the inner face of the chamber wall, is clamped a plate *P*<sub>1</sub>, which, like the cover, is punctured to permit the stem of the needle valve to slide through it. Plate *P*<sub>1</sub> has two vertical downward extensions, pierced by two pins *P* on which are hinged two weights *W* and *W*<sub>1</sub>, connected by a small round brass plate integral with the needle valve stem. When the chamber is empty the brass float *F*<sub>1</sub> assumes its lowest

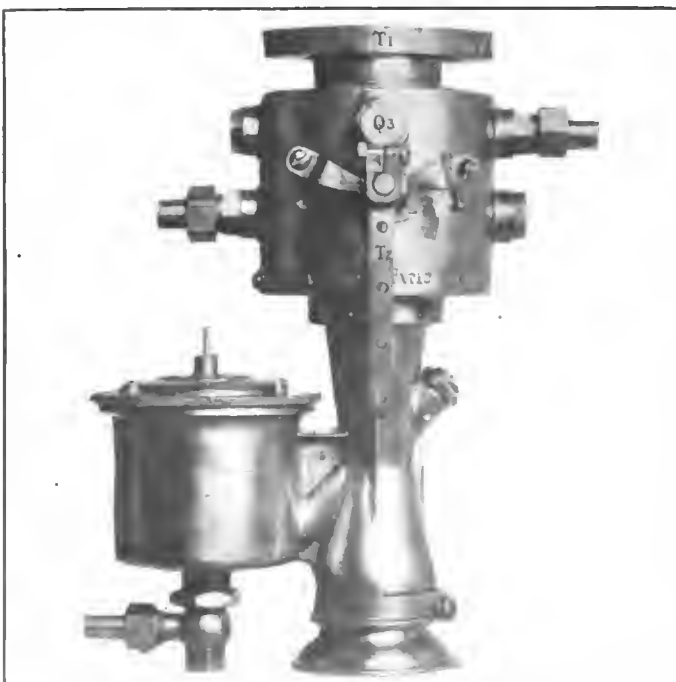

Fig. 1—Outside view of the G. & A. carbureter, indicating strength and compactness

possible position and the weights resting on it and fulcrumed on their pins lift the needle, thus making a free way for the gasoline into the chamber. If gasoline is admitted it lifts the float as high as the weights resting on it permit, at the same time depressing the needle, which closes the valve when the gasoline level is slightly above the nozzle *N*<sub>1</sub> leading up from the float chamber to the mixing chamber *C*<sub>1</sub>, so that the fuel flows out into same. The needle valve finds its seat in the brass fitting shown below the float chamber and which is capable of being removed from its place to drain off the gasoline or remove whatever foreign substances may have accumulated in the drainage space closed by plug *D*<sub>1</sub>.

The flow of air is regulated by means of the common lever and throttle, the butterfly being shown at *B*<sub>1</sub> in the mixing chamber. The air enters at the lower end *V*<sub>1</sub>, of the Venturi tube, after passing through a 30-mesh strainer *S*<sub>1</sub>, which serves to keep foreign matter out of the tube. This strainer is attached to a brass funnel of a diameter considerably larger than that of the pipe in order to take in as much air as possible. The Venturi tube, 1-2 inches wide at its lower end, narrows upward to a diameter of 9-16 inch and rises then as a parallel pipe for about half an inch. The parallel portion of the air passage is bored to provide a passage for the gasoline nozzle which ends at the upper level of this parallel portion and is almost centered in the pipe. The upper part *V*<sub>2</sub> of the Venturi tube is 3-8 inches up to the butterfly, and serves as the mixing chamber for the gasoline and air.

The auxiliary air inlet supplying the motor with an additional amount of air at the higher speeds has been constructed in the shape of a series of ball checks. Twelve balls of various diameters rest in cages upon holes in the part *M*<sub>2</sub> of the mixing chamber. About 7-16 inch above the plane of these holes an annular ring is provided. When the throttle is fully opened, the suction of the motor lifts these balls, and draws in air through the seats of the ball valves. Naturally, the smallest balls are first lifted, but their seats represent only small inlets for the outer air, and a stronger suction of the motor lifts the larger balls in their order of size, drawing in more and more air.

As the gasoline leaves the nozzle and is taken up by the swift-moving air streaming toward the motor, the liquid is atomized, *i.e.*, torn apart to form very small globules. But as gasoline cannot be burned completely except when in the gaseous state, designers of carbureters have found it of advantage to preheat the mixture of air and gasoline globules so as to completely vaporize the fuel before it enters the combustion chamber. This is done by water-jacketing the mixing chamber, and the water jacket is seen in Fig. 2 at *J*<sub>1</sub>. Apropos of water jackets in carbureters it may be well to remember that a fixed amount of gasoline has a certain heat of evaporation, that is, it absorbs a certain number of thermal units when converted into a vapor. In water-jacketing a carbureter, it is necessary for the designer to bear this in mind, since if not enough heat is supplied by the water to the mixture, the fuel will not be evaporated as completely as is to be desired. On the other hand, if too much hot water passes through the jacket and therefore more than the necessary heat is taken up by the gasoline, the fuel will enter the cylinders not only in vapor form but charged with a certain amount of heat, which goes to expand the mixture—even before it enters the combustion chamber—so that a lesser amount of mixture per stroke is taken into the cylinders. The varied demand for gasoline of the motor at different speeds as well as the changing atmospheric conditions render it impossible to

obtain, in a motor, at all times the ideal condition meant by what is called a totally cold compression, and it is therefore left to the designer to consider in his calculations as wide as possible a range of conditions of engine operation and to adapt his design of the details to the average of the requirements found out by his experiment.

The hot water enters and leaves through connections K1 and K2, and the illustration also shows one plug Q4 above one fitting and one Q2 below the other, so that in case a connection interferes with the crankcase or another part of the motor, a plug and fitting situated above one another may be exchanged, their threads being the same, making the connection and plug interchangeable. A third plug Q3 is so placed that it regulates the maximum and minimum opening of the throttle by holding up either of the two side members of the throttle lever T1. A fourth plug is placed on the casting opposite the plug Q3.

One more plug Q1 can be seen in Fig. 2, and this opens the passageway permitting of access to the nozzle when the latter is adjusted before the carbureter goes on the car. This plug is not to be removed except when the work named is being done, since the user of a car will find it of no use, but perhaps of disadvantage, to tinker with the nozzle which is made stationary in order not to be tinkered with.

The top piece T1 is threaded to screw into the top of the space above the throttle and it carries a flange of 7-16 inch thickness for attaching the carbureter to the manifold.

The G. & A. Carbureter Company, of 250 West Forty-ninth street, New York City, makes this carbureter. Several kinds of nozzles are made to fit into the 1912 models of this carbureter, and the company itself in fitting a carbureter to an automobile selects the nozzle that will give the best service and adjusts it to attain this end. When this work is being done it is necessary to unscrew the plug opposite the nozzle outlet in order to get at the threaded pipe connecting float and mixing chambers of the carbureter. After this the plug has filled its mission.

**GRITTING OF LONDON STREETS.**—As the time of the year when street surfaces are often greasy and slippery, owing to weather conditions, is now approaching the Roads Improvement Association of England has addressed a letter to all the Metropolitan

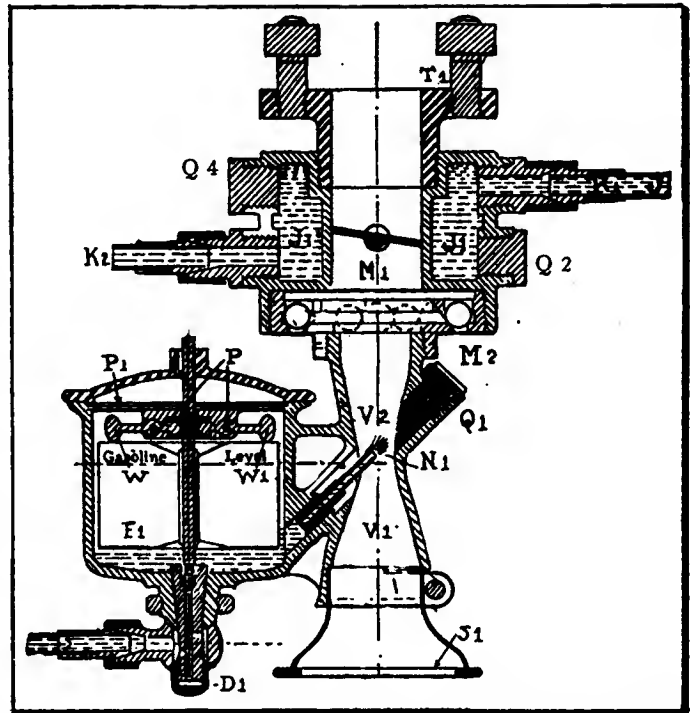

Fig. 2.—Cross section of G. & A. carbureter, illustrating principle of automatic operation

Local Authorities of London urging that any material that is used for the gritting of the streets should be as small as possible. It is pointed that the larger material causes damage to rubber tires and is of no service as a preventative of slipping until crushed. The gritting question was very fully considered at a conference between the Institution of Municipal and County Engineers and the Roads Improvement Association last June. The conference then held unanimously urged the thorough cleaning of all highways so as to reduce the necessity of gritting to a minimum and that any material that is used for the purpose should be as small as possible compatible with efficiency.

## Calendar of Coming Events

### Showa

- |                     |  |                     |   |
|---------------------|--|---------------------|---|
| Nov. 20-25.....     | Indianapolis, Ind., Fall Show, Indianapolis Automobile Trade Association.  | Feb. 17-24.....     | Newark, N. J., Fifth Annual Automobile Show, New Jersey Automobile Exhibition Company, First Regiment Armory.           |
| Dec. 30-Jan. 6..... | Buffalo, N. Y., Annual Show, Seventy-fourth Regiment Armory, Buffalo Automobile Trade Association.   | Feb. 17-24.....     | Minneapolis, Minn., National Guard Armory and Coliseum, Annual Automobile Show, Minneapolis Automobile Show Association |
| Jan. 2-11.....      | New York City, Hotel Astor, Importers' Salon.  | Pittsburg, Pa.,     | Second Annual Show, Exposition Bldg., Pittsburg Auto Show Association, Inc.   |
| Jan. 6-13.....      | New York City, Madison Square Garden, Twelfth Annual Show, Pleasure Car Division, Automobile Board of Trade.   | Feb. 17-24.....     | Hartford, Conn., Annual Show, Automobile Club of Hartford, State Armory.  |
| Jan. 6-20.....      | New York City, Madison Square Garden, Annual Show, Motor and Accessory Manufacturers.  | Feb. 20-24.....     | Binghamton, N. Y., State Armory, Third Annual Show, Automobile Dealers' Association.                                    |
| Jan. 10-17.....     | New York City, Grand Central Palace, Twelfth Annual Show, National Association of Automobile Manufacturers; also Motor and Accessory Manufacturers.  | Week Feb. 22.....   | Cincinnati, O., Annual Show, Cincinnati Automobile Dealers' Association.  |
| Jan. 13-27.....     | Philadelphia, Annual Show, First and Third Regiment Armories, Philadelphia Automobile Trade Association.   | March 2-9.....      | Boston, Mass., Tenth Annual Show, Boston Automobile Dealers' Association, Inc.  |
| Jan. 15-20.....     | New York City, Madison Square Garden, Twelfth Annual Show, Commercial Division, Automobile Board of Trade.   | March 4-9.....      | Denver, Col., Auditorium, Annual Show. Meetings, Etc.   |
| Jan. 13-19.....     | Milwaukee, Wis., Auditorium, Fourth Annual Show, Milwaukee Automobile Dealers' Association   | Nov. 20-24.....     | Richmond, Va., First American Road Congress, under auspices of American Association for Highway Improvement.            |
| Jan. 22-27.....     | Detroit, Mich., Wayne Gardens, Eleventh Annual Show, Detroit Automobile Dealers' Association.  | Nov. 22.....        | Road Users' Day, under direction of Touring Club of America.  |
| Jan. 22-27.....     | Providence, R. I., Providence State Armory, Rhode Island Licensed Automobile Dealers' Association, Automobile and Accessories Show.  | Dec. 20.....        | New York City, Waldorf-Astoria, Annual Banquet of the Automobile Club of America.                                       |
| Jan. 27-Feb. 10.... | Chicago Coliseum, Eleventh Annual Automobile Show under the auspices of the National Association of Automobile Manufacturers. Pleasure cars, first week. Commercial vehicles, second week. | Jan. 18-20.....     | New York City, Annual Meeting of the Society of Automobile Engineers.   |
| Feb. 3-10.....      | Montreal, Canada, National Show, Drill Hall, Automobile Club of Canada.  |                     | Race Meets, Hill-Climbs, Etc.   |
| Feb. 5-17.....      | St. Louis, Mo., Coliseum, Annual Show, Pleasure cars, first week. Commercial vehicles, second week.  | Nov. 9-10.....      | Chicago, Team Match, Amateurs vs. Trade Members to Waukesha and Return. Chicago Automobile Club.                        |
| Feb. 12-17.....     | Kansas City, Mo., Annual Show, Convention Hall, Combined Association of Motor Car Dealers.   | Nov. 9, 10, 12..... | San Antonio, Tex., Track Races, San Antonio Auto Club.  |
| Feb. 14-17.....     | Grand Rapids, Mich., Third Annual Show.  | Nov. 13.....        | Harrisburg, Pa., Economy Run, Motor Club of Harrisburg.   |
|                     |  | Nov. 27.....        | Savannah, Ga., Vanderbilt Cup Race, Savannah Automobile Club.   |
|                     |  | Nov. 30.....        | Los Angeles, Cal., Track Races, Motordrome.   |
|                     |  | Nov. 30.....        | Savannah, Ga., Grand Prize Race, Savannah Automobile Club.  |
|                     |  | Dec. 25-26.....     | Los Angeles, Cal., Track Races, Motordrome.   |

# THE AUTOMOBILE

Vol. XXV

Thursday, November 9, 1911

No. 19

## THE CLASS JOURNAL COMPANY

H. M. SWETLAND, President

CONDE NAST, Vice-President and General Manager

E. M. COREY, Secretary and Treasurer

231-241 West 39th Street, New York City

Cable Address - - - - - Autoland, New York  
Long Distance Telephone - - - - - 2046 Bryant, New York

### SUBSCRIPTION RATES

United States and Mexico - - - - -	One Year, \$3.00
Other Countries in Postal Union, including Canada - - - - -	One Year, 5.00

To Subscribers—Do not send money by ordinary mail. Remit by Draft, Post-Office or Express Money Order, or Register your letter.

Entered at New York, N. Y., as second-class matter.  
The Automobile is a consolidation of The Automobile (monthly) and the Motor Review (weekly), May, 1902, Dealer and Repairman (monthly), October, 1903, and the Automobile Magazine (monthly), July, 1907.

## The Manufacturer's Burden

THE old adage of "Great oaks from little acorns grow" has its adaptation in the automobile field, and particularly in the contest departments. This was well illustrated in the recent reliability run of the Chicago Motor Club, in which some of the heaviest penalties were caused by very minor incidents at the start. One contestant had a little leak in the gasoline line where it joins with the base of the gasoline tank. This started a long line of trouble. The car body with fenders had to be taken off before the job could be properly soldered, a process which consumed several hours. But this work constituted only one chapter of the affair. While the repairs were being effected the car was falling behind on its schedule; this meant fast driving to catch up. The fast driving resulted in an accident with a farmer, who refused to pull a little to the right side of the road to allow the contesting automobile to pass. The net result was an accident, fenders and running boards torn off against a fence and more penalties for work and being late at the night control. All of this started from a little gasoline leak. Every maker would smile at a buyer who talked seriously over what he considered a weak gasoline feed line from the tank to the carbureter, and yet this proved in this contest a most serious affair, and one that would cost a private owner a good deal of money. The cause may have been a poor soldering job in the assembly room, or it may have been due to excessive vibration caused by fast driving. No matter what the cause, the result is known, and the moral to all car owners and car builders is that a big expense or repair bill may originate with what many would consider a very trifling trouble. The lesson to be gathered is that all of the little details on an automobile should be looked after, because the complete car has but the strength of its weakest part.

But the contest in question afforded one or two other examples of what the little acorn fable is intended to convey. One other contestant had continuous trouble due to a connection on a dry cell breaking off. The connection was broken and the car could not be started on a

cold morning on the magneto. Continuous cranking and straining on the starting crank broke the starting crank bracket and more or less trouble followed. Each time the car had to be started it had to be pushed. Two examples will suffice. The truth of the value of the small part is apparent.

The lessons taught by this run should be taken to heart by every maker. They will, if properly applied, prove the greatest salesman of new cars, and they will prove to be big money savers to the automobile owners. Nearly every trouble in a car starts from some little source. The car owner and driver fails to notice the little irregularity which could be corrected in less than 5 minutes. He keeps on driving his automobile from day to day; the trouble grows worse, not perceptibly at first, but soon the owner-driver becomes conscious that something is wrong. He tries to locate it and soon finds that there is a long chain of difficulties; one little trouble has led to another and soon half a dozen parts of his machine have become infected. The repair means several days in the garage, and several days in the garage means a whole lot of money in the repair bill. This big repair bill sets the owner-driver thinking and in nine cases out of ten he comes to the conclusion that what is needed is an inspection department by the branch house or the dealer. The owner-driver is not an apt mechanical physician; he has not the stethoscopic ear to interpret the little knock in the motor that may, if not corrected at once, lead to a new set of bushings for the crankshaft and connecting rods at an outlay of more than \$100. He is not capable of detecting the little clutch slip that, if not corrected at once, may require a new facing or some new disks. He cannot tell if the motor is getting enough lubricant or if the cylinders are filling up with carbon; in a word, he is not an automobile physician. He is not an expert at diagnosing troubles and, worse yet, he is not adept at prescribing remedies. A real doctor of automobiles and their troubles is needed. Each car owner cannot have his private physician. The car maker should supply the physician. The physician is the factory expert—the man who has worked through every department of the factory; the man who understands every in and out of the entire car; the man who can tell in an instant the cause of a certain irregularity, and who is as quick to provide a remedy; the man who can take a 15-minute ride once a month with every car owner and who can tell them in that time if every part of the car is working all right, and if any little symptoms of trouble are noted can suggest the remedy.

The answer to the need for automobile physicians points to the service department, whether conducted directly by the factory or by a competent dealer. The average repairman does not solve the problem. He takes the place of the patent medicine man in the medical field. He is supposed to be able to repair every make of car. How foolish such an idea! How can he make a good repair unless entirely familiar with the construction of the car parts and also familiar with the materials used in these parts and the treatment given these parts in the processes of manufacture? It is true that the repairman can do a great many things and can do them well, but often he fails to do a great many and does a host of others very poorly. He can do the ordinary work well, but fails badly when the more important jobs

have to be handled. A few examples will suffice to illustrate this: The repairman in some Nebraska city could not be expected to make a good job with a repair on a bent steering arm on a certain make of car when he was ignorant of the grade of steel used in this part and did not know the heat treatment it was given when it was being made. The same applies to springs, leaves of which have been broken and a temporary repair is wanted until a new spring can be had. In some cases the repairman makes a perfect job, one that will endure; but in others the repaired leaf has not given a day's service. The meaning attached to this is that by a plan of guess work he gave treatment that was well suited in one case; it was just the kind of treatment that grade of spring steel demanded, but in the other case the treatment was perhaps the worst that could be given. Here is where the man trained in the factory can give good service at the branch houses or service departments throughout the country. The modern car calls for trained workmanship and scientific workmanship. In plenty of the cities throughout the country the head repairman is a person who has graduated from some blacksmith shop field. He has never had a thorough experience in the automobile field. His case is similar to calling in a veterinary to treat a human being. Skilled treatment is needed and a man skilled in the treatment of one make of car may be a dismal failure in similar treatments on other makes of cars, simply because different materials are used and these materials have been given different treatments in the processes of manufac-

ture. The crux of the entire situation is that the car maker must look after his customers, otherwise they will get away from him. It will pay each automobile maker to establish service departments in the big centers of population where his car is sold. It will pay him to have a free inspection department, in which once a month each owner can have his car given a 15-minute official run under the control of the automobile physician. If it is running well, nothing has to be done, but if some trouble is developing it can be nipped in the bud. This nipping of troubles in the bud saves the reputation of the car and also saves the pocketbook of the owner. If some work has to be done on the car the owner should pay labor rates for it, and if it be advisable to add some new parts, then he should pay a legitimate price for these parts. It is much better for him to pay \$1 to rectify a trouble to-day, which if let run would mean a bill of \$100 in less than a month. Service departments are needed. If a maker cannot install gilt-edged departments at once, install poorer ones; but make a start. If it is not satisfactory to open branches and erect big, costly buildings, then install humble quarters with the dealer. But give satisfaction to the owner. Give him intelligent repair service and give it to him at a reasonable cost. Do not try to make money out of the owner because of the failures in your designing or manufacturing departments in turning out automobiles that are not perfect. Be ready to carry your share of the burden. The welfare of the entire automobile industry demands this.

## Savannah Card Filling

SAVANNAH, GA., Nov. 8—With the entry list for the four big road races to be decided the latter part of this month reaching a total of thirty-one to-day and with still a full week intervening between to-day and the closing of the entry box, indications point to the coming race meeting as the greatest in the history of automobile racing.

It is understood that there will be at least twenty-five more cars entered and there is a strong probability that even a larger number will try conclusions. The only Indianapolis factory entries so far received have been those of the Marmon fleet consisting of two cars in each the Grand Prize and Vanderbilt and three in the Savannah trophy race. Among the Indiana cars expected in addition to the Marmons are several from the National factory, a Cole or two, a Westcott and perhaps a Stutz car.

Following are the official entries:

*Grand Prize*—3 Fiats, 3 Benz, 2 Marmons, 2 Loziers, 1 Mercedes.

*Vanderbilt*—2 Mercedes, 3 Fiats, 2 Marmons, 2 Abbotts, 2 Loziers.

*Savannah Challenge*—2 Cases, 2 Abbotts, 3 Marmons, 2 Mercers.

*Tiedeman*—2 Abbotts, 3 E-M-Fs.

All of the net profits of the races will go to the military of Savannah. To the efficiency of this well-drilled body is due the absence of accidents on the course in the past, and this disposition of the receipts meets with the approval of all concerned. The detail will consist of six companies of the First Infantry, four companies of heavy artillery, a troop of cavalry, a battery of light artillery, and two divisions of naval reserves. Sheriff Screven and his forces will also assist in the work of guarding the 17-mile course.

## Akron Growing Rapidly

AKRON, O., Nov. 6—Due largely to the development of the automobile industry, Akron, the "rubber town," has had the following increases in the five years 1904 to 1909, according to reports just made public by the United States Census Bureau, Division of Manufacturers:

One hundred and eighteen per cent. in the value of manufactured products; 111 per cent. in the value of materials used; 103 per cent. in the amount of capital invested, and 32 per cent. in the number of manufacturing establishments. This is a record for cities of Akron's grade and population, 70,000.

If the figures were taken at the close of 1911 instead of 1909, the results would be still more striking, for the Diamond Rubber Company, the B. F. Goodrich Company, The Firestone Tire & Rubber Company, The Goodyear Tire & Rubber Company and all other tire makers have developed considerably of late.

Thirty thousand Akron people are supported, directly or indirectly, by the rubber industry, and in that industry all possible pressure and concentration is directed to the tire branch.

It is significant that in the improvements and additions made to Akron rubber factories, the best of material and expensive innovations are used. This is explained by leaders of the industry on the ground that they are certain the automobile industry will continue to grow and develop indefinitely and they must build not only for the present, but for the future.

## Pittsburgh to Have Two Shows

PITTSBURGH, PA., Nov. 6—There will be two shows held in this city next Spring. The sixth annual show will be held in Duquesne Garden in February, and the second annual exhibition of the Pittsburgh Auto Show Association, Inc., is scheduled for Feb. 17-24.



## National Wins Phoenix Desert Race

PHOENIX, ARIZONA, Nov. 7—For the first time in the history of automobile racing, a Western event of national importance has been won 2 years in succession by the same man. Harvey Herrick, who won the Los Angeles-Phoenix road race a year ago in a Kissel car, this year piloted a National to victory. Ralph Hamlin, second last year in the Franklin, used the same machine and took the same position. The National's running time over the 542-mile course was 20 hours and 22 minutes, while that of the Franklin was 22 hours, 54 minutes, 35 seconds. The Midland car, driven by Tom Carrigan, captured third honors, negotiating the distance in 24 hours, 21 minutes and 24 seconds.

The course is a trying one and tested the mettle of men and cars to the utmost. Machines and drivers were covered with thick coats of dust upon their arrival. Several had no sleep from Saturday morning until late Monday night.

For days before the start of the race, Saturday night, there had been no rain and the course was in as good condition as it ever was, but at its best is terrifying. There are stretches of 50 miles without water or human habitation. Herrick took the lead right at the start and maintained it to the finish. He could have finished an hour sooner. Herrick's proverbial luck and the National's staying qualities carried them into San Diego for the special prize of \$1,000 for the first car to reach that place, far in advance of the other machines. Then Herrick was off over the sands of southern California, across the brush-covered flats of Mexico to Yuma, Arizona, where he won another \$1,000.

He pulled into Yuma, 330 miles from Los Angeles, at 11:49 Sunday morning. His running time had been 12 hours and 14 minutes. Leaving Yuma at 5:03 the next morning the National shot away for Dome, 20 miles distant. He went into control only 1 minute ahead of the Mercer. This was the nearest Herrick came to losing his lead. All the cars were held in control at Dome until they could be hauled across the Gila River. The Franklin and Mercer pressed the National closely this side of the river but gradually Herrick pulled away. The last 150 miles was easy for him, he did not let out the National at all. Once E. Swanson, his mechanic was jolted out but Herrick playfully ran on half a mile, forcing Swanson to scamper along to keep up before he would let him in. At 1:51 1-2 Monday afternoon the National crossed the line at the Arizona Fair Grounds.

Herrick, who was born and reared in Phoenix, received the applause of 7,000 people. The Franklin arrived at 2:35. Hamlin drove a splendid race and but for an unfortunate accident on the California desert might have beaten Herrick. The Franklin broke a spring near El Centra and spent over an hour in a blacksmith's shop. Tom Carrigan took third place with the Midland, a dark horse, because he had better luck than drivers of heavier and faster cars. He had practically no trouble along the route.

A protest which may prevent the Midland being formally awarded third money has been filed with the A. A. A. representative by Louis Nikrent, driver of the Buick No. 12. Nikrent was getting along pretty well until he was this side of Yuma, when part of the Buick's machinery began to give trouble. He decided that he had no chance to win with his car, so when the Buick No. 16, driven by Billie Ferguson, of Bisbee, Arizona, came along he took its wheel. Ferguson's mechanic, Carey King, was left to help Nikrent's mechanic get the disabled car into Phoenix, but the mechanics beat their drivers. They claim that they arrived at 5:03 but found no one to check them in. They were put down as arriving at 5:16. If the protest of

Nikrent is allowed, No. 16 will be given third honors. It is claimed that since Nikrent deserted his own car it was disqualified. The Buick 16 was checked in fourth by the local officials, its running time being 26 hours 26 minutes 35 seconds.

The most serious accident of the race occurred to the Fiat. A mile east of San Diego the lights went out and the car crashed into a telegraph pole. Teddy Tetzlaff, the driver, was hurt, while Felix Magone, his mechanic, was seriously injured. Both are in hospital at San Diego. The Fiat was destroyed.

Earl Fancher, mechanic to Earl Smith, the Maxwell driver, is also in San Diego hospital. Twice between Los Angeles and San Diego the Maxwell turned over. Just out of San Diego it turned over the third time, Smith and Fancher being pinned underneath. Roger Stearns, driving the Stoddard-Dayton, stopped to give assistance and lost his chance of beating the National into Yuma. Smith was able to finish the race with another mechanic.

At Santa Ana the Pope-Hartford, a Phoenix car driven by W. D. Tremaine, had one rim fly off the front wheel and crashed into a curbing, breaking two more wheels. It was delayed there 12 hours until new wheels could be secured. Tremaine drove on to San Diego, Yuma and Phoenix and arrived second, though his running time was so great as to preclude him from participation in the prize money. His plucky race after his luck was one of the most sensational features of the contest. His running time between Yuma and Phoenix was better than that of any car except the Cadillac.

W. W. Bramlette, in the Cadillac, made a good showing this side of Yuma, but the other side his time was slow. Hard luck stuck to Roger Stearns and the Stoddard-Dayton. Before he stopped to assist the Maxwell, he had had trouble. Despite delay and trouble he was only 47 minutes behind the National at Yuma, in running time. He had to stop out of control the next morning to put in a new axle and that put him out of the running.

The Mercer, driven by Harris Hanshue, was a serious contender until Dome was passed. It was right up with the Franklin and National but Hanshue got lost and broke a steering knuckle and did not arrive until midnight.

The Flanders negotiated the distance between Los Angeles and Yuma in 16 hours and 43 minutes, putting it in seventh place. A mile out of Yuma it was put out of the race.

Bill LaCassel drove a good race in the E-M-F, arriving in Phoenix at 9:10 Monday evening. Minor troubles delayed him on both sides of the river.

One of the favorites, the Cole, made a poor showing in time. Its engine was jarred loose and it dragged all the way. The Cole arrived this morning.

The Lexington, driven by Charles Bigelow, made a good showing for a comparatively light car. It arrived about midnight after having experienced various tire and engine difficulties.

Only meager reports have been received of the Case, a Phoenix car driven by W. F. Brong which was last seen in a ditch between San Diego and El Centra. Brong and his mechanic were asleep beside it.

### Election Day Races at White Plains

WHITE PLAINS, NOV. 8—Election Day was celebrated here with a series of automobile track races on the half-mile track of the fair association. Three races were run: Maxwell (Costello) winning at 10 miles; Abbott-Detroit (Mulhall) at 5 miles and Mercer (Monroe), free-for-all at 10 miles.

# National Wins Thrice at Minneapolis

**M**INNEAPOLIS, Nov. 6—Facing a raw wind blowing across the city, 500 spectators Saturday witnessed the hill climbing contest which was held on Columbia Heights hill under the auspices of the Minnesota Motor Club. Barring the low temperature, conditions were ideal, the road having previously been placed in almost perfect condition.

The time was taken by flagging the timers at the finish line when each car crossed the starting tape. As a result several watches were at variance, being in one instance 6 seconds apart.

National (Reiter), entered by the Northwestern Overland Company, captured three prizes, the George B. Levy, Prest-O-Lite and Hollis Electric trophies going to it. This car won in Division 4 for cars of from 301 to 450 inches displacement, the free-for-all event and for making the best time up the hill regardless of class.

This climb marked the initial appearance of National cars in competition under sanction in the Northwest. The best time recorded for the National was in one of its early trials, when it was piloted up the grade in 19 3-5 seconds. Its best time in the free-for-all was 20 3-5 seconds. Tying for second place in the free-for-all event were the Colby and the Ford entrants, both taking the ascent in 21 3-5 seconds.

In Division 1 the Flanders won the Republic Rubber Company trophy for cars of 160 inches displacement and under. Its time was 23:27 seconds, the average computed by the timers. This car was entered by the Studebaker Corporation and was driven by Simon Rothenberger. There was no other contestant in this division.

By making the fastest time for cars having from 161 to 230 cubic inches the Ford driven by John McDowell secured the trophy given by R. J. Randolph. Al. Wilson's Jackson qualified for the Automobile Equipment trophy, the second prize in this division. His time was 22:49 seconds. Gus Hansom, in a Ford; Dick Stanton, in a Cutting, and an Overland were the other contestants. The time between them was rather close.

It was a pretty fight between the Colby and the Everitt, driven by Matt Miles, when these cars lined up for prizes offered in the 231 to 300-inch displacement class. The Colby won, making the distance in 22 1-5 seconds. By its victory it becomes the possessor of the Empire Tire & Rubber Company's trophy, while that offered by the Superior Oil Company goes to the Everitt, entered by McArthur-Zollars-Thompson.

Art Murphy in a Speedwell, entered by the Hudson-Thurber Company, captured the Van Tilburg Oil Company's cup by finishing second in the event for cars from 301 to 450 inches. This was the event in which the National finished first.

In the big class, a Peerless, entered by T. M. Anderson and driven by Ase Precourt, ran with regular touring body and full equipment. This car won the event in the 451 to 600 class, making the climb in 27 1-5 seconds. The Pure Oil Company had offered a trophy for the winner. M. R. Nyman in an Alco finished second in the event. His time was 31 second. The Alco also was equipped with a heavy body.

The climb was 1,300 feet long, with an average grade amounting to 6.63 per cent. The greatest grade at any one place was 10.4 per cent., while the total elevation was 86.2 feet.

## Quakers Abandon Reliability Run

PHILADELPHIA, Nov. 4—Owing to the small number of entries received for the Philadelphia Reliability Run, scheduled for November 2-4, and the general lack of interest in the event, the Quaker City Motor Club decided not to attempt to hold it. The

club regretted to give up the project, as its runs have always been so successful and so productive of pleasure and profitable experience to both participants and officials.

It is thought that the lack of interest shown in the run is due, in some measure, to the concentration of the attention of the automobile public of Philadelphia on the Fairmount Park Race.

## Wisconsin to Educate Public

MILWAUKEE, Nov. 6—The new Wisconsin Highway Commission created by a law appropriating \$350,000 annually for State aid for highway improvements will on November 14 put in effect a comprehensive educational plan covering about half the State and with particular reference to the localities that have availed themselves of State aid by appropriating sums for good roads work.

The members of the commission and its engineers will address county and town boards on the provisions of the law and on highway improvement in general.

The speakers will be: John A. Hazelwood, chairman; Senator John S. Donald, Senator E. E. Browne, A. R. Hirst, State highway engineer; M. W. Torkelson, bridge engineer, and W. C. Buetow, assistant bridge engineer. Each of the meetings will be made into a "Good Roads" rally and the entire scheme will be one of the greatest value from an educational standpoint that good roads workers in Wisconsin have ever experienced.

## Milwaukee Is After Boy Drivers

MILWAUKEE, Wis., Nov. 6—To prohibit any person under 21 years of age from operating motor cars in the city of Milwaukee is the object of an ordinance now being framed by the Municipal administration for presentation to the common council. The proposition has aroused a storm of indignation and it is thought at this time that such a law will have slight changes for passage.

The object of the ordinance is claimed to be to curb "joy-riding" instincts of the young. It would also prohibit girls under 18 years of age from being in any motor car operated by any person under 21 years of age, unless they have the consent of parents or guardians.

Leading attorneys doubt the right of the municipality to legislate all persons under 21 from operating motor cars. It would be an encroachment upon the State law, which restricts the operation of motor vehicles to all persons over 16 years, excepting that a person 16 years or younger may drive when accompanied by parent or guardian.

## Touring and Camping—The Ideal Vacation

The recent Summer season saw more people than ever before enjoying the delights of automobile touring. One of the most interesting which has come to our notice is that made by Mr. W. M. Leftwich, a prominent engineer of Nashville, Tenn. Mr. Leftwich decided to make his tour a "go-as-you-please" affair, not planning to reach a given point each night. In order to accomplish this he carried sleeping bags for the party of seven, and also included a compact cooking outfit. His big six-cylinder Locomobile afforded ample room for this equipment.

The route led from Nashville, Tenn., through Kentucky, Ohio, New York and New England, into Canada, which was entered twice on the trip, Quebec being the first place visited, and later on the party toured in quaint old Nova Scotia. The tour covered over 5,000 miles.

# T. C. A. Scouts Arrive at Richmond

**R**ICHMOND, VA., Nov. 6—The cars containing the good roads scouts of the Touring Club of America arrived in Richmond at 3 p. m. Saturday afternoon, having covered the entire distance of 725 miles since Tuesday morning at 11 o'clock. This trip was undertaken to lay out a practicable route for good roads enthusiasts who want to make the trip by auto from Atlanta to the first annual Road Congress of the American Association for Highway Improvement, which takes place at Richmond, November 22.

The cars used in making this trip were the Chalmers Six, which was an official press car for the Glidden Tour. This car was taken off the train Tuesday morning at 9 o'clock and was immediately put into service for the run without any repairs or attention other than filling up with oil and gasoline. The car reached Richmond in perfect condition and without any tire trouble whatever, although the roads were anything but smooth. In this car were Henry MacNair, editor of the *Blue Book*, pilot of the party; W. Douglas Gordon, Police Commissioner of Richmond and correspondent of the *Times-Dispatch*; Lee A. Folger, manager of the Gordon Motor Company, of Richmond, and W. A. Vibbert, official photographer, who was also on the Glidden Tour. The car was driven by Freeman Monroe, of the Chalmers factory in Detroit. The second car was a Mitchell Six, carrying Frederick H. Elliott, secretary of the Touring Club of America; D. D. Armstrong, vice-president and manager of the Southern department of the T. C. A., and H. B. Varner, editor of *Southern Good Roads*. The car was driven by Chas. T. Oley, of the Mitchell factory at Racine. Both the cars came through without any serious mishap, although the Mitchell was slightly delayed on the last day by tire trouble.

The party left Georgian Terrace at Atlanta on Tuesday morning at 11 o'clock and arrived in Augusta at 9:30 p. m.

In Augusta they were met by E. J. Watson, Commissioner of Agriculture of South Carolina, and party, who escorted the cars to Columbia the next day. Some of the road was very rough and the escort car broke a front axle in one of the chuck-holes. At Columbia the party was met by many prominent citizens and was entertained at the Columbia and Metropolitan clubs. The next day's run was from Columbia to Pinehurst, a distance of 175 miles, nearly all of which is good sand-clay road.

At Pinehurst the party was met by Leonard Tufts, president of the Capital Highway Association, who entertained them royally and piloted them out of town next day over a new sand-clay road which is being constructed between Pinchurst and Fayetteville. Between Fayetteville and Raleigh the going was the worst of the trip, but Cumberland County has issued bonds for \$200,000 which will be immediately used for building sand-clay roads. A luncheon stop was made at Raleigh and the party pushed on to Henderson, N. C., for the night stop.

At Henderson an early start was made Saturday morning and between Barley and Emporia, Va., the finest road was negotiated. This, as with all of the other good roads on the trip, was sand-clay costing about \$500 a mile. The cars traveled along on this trip at forty miles an hour as comfortably as on the finest macadam boulevard. But beyond Emporia the going was very bad.

At Petersburg an escort party headed by W. T. Daloney met the cars. The road from Petersburg to Richmond is also sand-clay road and has been recently resurfaced so that the last 22 miles of the distance were made in 40 minutes. The tourists were loud in their praises of the hospitality and enthusiasm along the line. The consensus of opinion is that with very little work and a moderate sum of money the entire trip from Atlanta to Richmond can be made to compare with any similar trip in the Northern States.

The complete official program for the congress is as follows:

## NATIONAL DAY, NOVEMBER 20.

Morning Session—Address by Governor William H. Mann, of Virginia; address of welcome by Hon. D. C. Richardson, Mayor of Richmond; opening address by Logan Waller Page, president of the American Association for Highway Improvements; address by William Howard Taft, president of the United States; address by W. W. Finley, president of the Southern Railway Company; address by Hon. J. Hampton Moore, of Philadelphia, president of the Atlantic Deeper Waterways Association.

Afternoon Session—Address by Hon. Thomas S. Martin and Hon. Claude A. Swanson, United States Senators from Virginia.

Evening—Smoker at the Jefferson Hotel, arranged by the Chamber of Commerce and the city of Richmond.

## CONTRACTORS' DAY, NOVEMBER 21.

Harold Parker, chairman; chairman's address; address by W. A. McLean, Toronto, Canada; address by P. St. Julien Wilson, State Highway Commissioner of Virginia; address by J. B. Girard, territorial engineer of Arizona; address by W. W. Cosby, State Highway Engineer of Maryland; address by Arthur H. Blanchard, professor of highway engineering, Columbian University.

Afternoon—Addresses by D. L. Hough, president United Engineering and Contracting Company; Mr. Bates and other contractors. Discussion, "The Relation of the Road Contractor to the Engineer."

Evening—Reception in Governor's mansion to all delegates.

## ROAD USERS' DAY, NOVEMBER 22.

Address of welcome on behalf of the automobilists of Virginia, Preston Belvin, president of the Virginia Automobile Association; addresses by Hugh Chalmers, Detroit; Sidney A. Gorham, Chicago; Matthew S. Rogers, secretary State of Connecticut, "What It Has Done for Good Roads"; Colonel Charles Clifton, of Buffalo; Davis Dancroft, Chicago; Henry Fairfax, Virginia; Edward Lazansky, secretary of State of New York.

## ASSOCIATION DAY, NOVEMBER 23.

Dr. Joseph Hyde Pratt, State geologist of North Carolina, presiding. Address on the use of convict labor in road building by Dr. Pratt. Discussion opened by S. W. McCallie, State geologist of Georgia. Other discussions of this session will be participated in by Jesse Taylor, secretary of the Ohio Good Roads Federation; W. D. Brown, editor *Rural Free Delivery News*; Leslie T. McCleary, of New York, representing the Lincoln Memorial Association; Dudley Field Malone, of the National Highways Protective Society, of New York; representatives of automobile associations, national civic federations and representatives of farmers' and labor organizations.

The afternoon session will be devoted to the election of officers of the association, selection of place for next meeting and the transaction of other business.

## President Taft to Be Guest of A. C. A.

President Taft will be the guest of honor at the annual banquet of the Automobile Club of America, which is to be held at the Waldorf-Astoria on December 20. Fully 1,500 club members and their guests are expected to be in attendance.

In addition to President Taft the invited guests will include Vice-president Sherman, the Secretaries of State, War, Navy, Treasury, Agriculture, Commerce and Labor and Interior; Postmaster-General, Attorney-General and the Solicitor-General.

## Body Styles at the Berlin Show

ACCORDING to German contemporaries, the considerable extent to which professionally educated artists, who abound in Germany, have lent their services to automobile manufacturers and body builders during the past year is one feature in the recent industrial development which has left its mark most plainly on the vehicles exhibited at Berlin. The departures from current styles in body design and equipment are bold and numerous. Some of them are dashing; others only help out utilitarian purpose.

In a general way it is noticeable that design runs to long continuous lines with a somewhat studied avoidance of mouldings and corners. The Utermoehle firm has succeeded in producing a phaeton which can be converted into a limousine and yet presents none of the makeshift lines, from an artistic standpoint considered, which have heretofore always been characteristic of convertible types. The same vehicle is equipped with extra-seats which disappear invisibly in the back of the front seats when not wanted, a single lever movement sufficing to throw each of them in or out. A large number of closed cars are provided with frameless window panes of a new patented style, and specially suspended armchair seats, known as the Wildening *Schwebesitz* or floating seat, are a new article of luxury intercepting practically all vehicle movement arising from sudden starts, stops and road shocks. The Kellner firm, which has nothing to do with Paris firm of the same name, seems to shake new ideas out of its sleeves. Its open car bodies are equipped with an electric light, designated as a map-reading lamp but equally useful for reading newspapers in the open. and its interior upholstery of limousines, all in leather, including the ceiling, produces an entirely novel effect of elegance, largely because the firm seems to have developed a new technique in leather finish. And it is said to have spent large sums for its experiments in this departure. Hunting cars in natural wood finish and with very strongly curved surfaces also present a striking effect, while the Windhoff limousine in Prince Henry style, very pointed in front and rounded at the rear and mentioned as the "type of the future," seems somewhat fantastic.

The use of windshields for rear as well as front seats is observed in a number of vehicles.

A modern demand for having all accessories disposed of inside of the carriage body accounts for the conspicuous novelty in the body design placed upon a Benz chassis by the Carl Toenjes firm of Delmenhorst. The lines are shown in the accompanying illustration copied from a half-tone in *Allgemeine Automobil Zeitung*. Even the travelling trunks are here protected against dust and grime and the spare tires rest on the running board inside of the side panel. The latter is not vertical but leans outward at the top. All the lines, particularly at the rear are designed with a view to reducing air resistance below that encountered in cars of customary design, and also to avoiding that formation of eddies which raises the dust of the road. In this instance the co-operation of a firm of artists—Ernst Neumann—is distinctly acknowledged, though the type is announced as only a first attempt to become the foundation for further efforts.

### Impressions of an American Visitor.

BERLIN, Oct. 21.—One of the most striking features of the International Automobile Show from an American point of view is the entire absence of six-cylinder cars. Not a single German manufacturer is exhibiting a car of this type, and the only one that does exhibit such a car is the English Daimler, which has

a beautiful six-cylinder chassis with Knight engine on exhibition. [A six-cylinder Protos car is also shown.—ED.]

Another very marked tendency is the bringing out of low-powered and low-priced models by many of the European manufacturers with the evident intention of preventing the capture of this class of trade by the American manufacturers who are now making a strong effort to secure the market for cheap cars. The only American cars exhibited are Ford, Mitchell, E-M-F and Flanders. The European manufacturers who exhibit cars of this class include Adler, Laurin and Klement, Stoewer and the French firm Clement-Bayard, and others. Each of the companies named exhibit four-cylinder cars ranging from \$900 to \$1,300 completely equipped. One of the best examples of this type is a very smart little four-seated torpedo by Laurin and Klement, listed at \$1,275, and said to be capable of fifty miles an hour on the road.

A line of cars of striking originality in body design is very much in evidence. This is a type known as the Prince Henry, and is cigar-shaped. The hood is extended in a funnel-shaped manner to include the dash, which in many cases contains the gasoline tank, and this is so built into the dash as to be entirely out of the way, and the filler is in the centre on the front, so that it can be filled without disturbing any part of the



Side view of the all-enclosing carriage body placed upon a Benz chassis by the Delmenhorst Wagon Company

interior of the car; the filler is practically the same as the radiator cap. The body is long and narrow with only two seats in the rear with a handsomely upholstered arm rest between them, and in many models there are two folding seats, and the back of the front seats are in some cases upholstered in leather and in others are used as cupboards for carrying various articles that may be needed. The dash extends well back and flares up so as to help deflect the wind from the occupants of the front seats. The back of the front seats also have this same flare with the object of protecting the occupants of the rear seats. The general appearance of this type of body is pleasing, and it is rounded off at the rear so as to avoid as much as possible eddying currents of air which would otherwise tend to stir up dust.

The Minerva and Daimler exhibits of working models of the Knight engine with portions cut away to show the mechanism attract great attention and their stands are constantly crowded with visitors. The Minerva Company exhibits a 26-horsepower chassis with 1912 model engine with chain drive for pump and magneto, the latter having automatic advance ignition with only one lever on the steering wheel.

# News of Shows—National and Local

SHOW announcements in New York were scarce again during the past week. The chief happening was the progress noted in the Palace show arrangements. As was chronicled at the time of the allotment of space to the Gramm and Kelly trucks in *THE AUTOMOBILE*, a protest was made giving those companies space on the second floor.

Mr. Gramm entered an informal objection to such an allotment and this week it has been announced that both the Gramm and Kelly vehicles will be shown on the main floor in conjunction with the pleasure automobiles.

It was the original intention of the National Association of Automobile Manufacturers to exhibit all the trucks on the main floor, around the other exhibits. This plan was later modified and the trucks were spaced in the second floor. As it is now, all the trucks except the Gramms and Kellys will be gathered on the second floor.

Accessory manufacturers sufficient to take up a large amount of space on the third floor have already been signed up and the prediction is made by officers of the association that all the space will be contracted for before the end of another week.

## Show Arrangements in Quaker City

PHILADELPHIA, Nov. 6—Philadelphia's annual automobile show, again under the auspices of the Philadelphia Automobile Trade Association, will be held from Saturday, January 13, to Saturday, January 27, 1912, inclusive.

A building of sufficient proportions to house the entire exhibition under a single roof still being conspicuous by its absence, the same arrangements for accommodations as were in force last year will apply to this year's show, it being held simultaneously in two separate buildings, uptown in the First Regiment Armory, Broad and Callowhill streets, right in the heart of the automobile selling district, and downtown in the Third Regiment Armory, Broad and Wharton streets.

The first-named building during the initial week will be devoted to gasoline pleasure cars exclusively, the downtown structure to gasoline pleasure cars and accessories. For the second week the scene will be shifted at both armories—the gasoline cars uptown giving way to electrics and electrical devices, while downtown gasoline and electric commercial vehicles will hold the boards.

The Trade Association has appointed the following officers of the show: George W. Hipple, of the Chalmers-Hipple Motor Car Company, president of the Philadelphia Automobile Trade Association, to be chairman; Frank Eveland, manager of the A. G. Spalding branch, handling the Stevens-Duryea car, and J. A. Wister, of Gawthrop & Wister, agents for the Elmore and Brush. J. H. Beck will again manage the show for the fifth consecutive year.

## Milwaukee Show Date Advanced One Week

MILWAUKEE, Wis., Nov. 6—The Milwaukee Automobile Dealers' Association has decided to hold its second annual motor show in the Auditorium beginning on January 13, and closing on January 19, instead of from Jan. 20 to 26, as previously announced.

More than 65,000 square feet of floor space will be used for the 1912 show, which is the fourth to be held in Milwaukee. The first two shows were given by the Milwaukee Automobile Club.

Only cars represented by Milwaukee county agencies will be

permitted in the display, as last year, when 53 pleasure car makers and 17 commercial vehicle manufacturers were represented. Since last January, 29 additional pleasure cars have gained representation in the city and 14 more commercial car builders have been added to the list handled here.

Frank J. Edwards, manager of the Kissel Kar Co., has been appointed chairman of the show committee and Bart J. Ruddle will again act as general manager. The other members of the show committee are: Edgar Sanger, representing the Maxwell, Stearns and Columbia; Alfred Reeke, manager of the Milwaukee branch of the Thomas B. Jeffery Company; George W. Browne, distributor for the Overland and Marmon, and Robert G. Bates, agent for the Abbott-Detroit and White cars.

## But One Show in Kansas City

KANSAS CITY, Mo., Nov. 6—Kansas City is to have but one show this year. Last year, and the year before, owing to a disagreement among the dealers, two shows were given; but the antagonistic factions have agreed on the matters that were keeping them apart and one association has been formed, which includes all of the dealers in the city. The membership consists of more than sixty different companies, so that the coming show will be an immense one. It will take place in Convention Hall, which is the largest building for exhibition purposes in the West. Two balconies, in addition to the one already in the hall, will be necessary to accommodate all the dealers and the big accessory department.

Kansas City shows are always important events, owing to the fact that Kansas City is the gateway to the Great Southwest, a section in which more cars are sold annually than in any other locality of equal area in the United States.

The date of the show is the week of February 12th, 1912. There will be departments for gasoline pleasure cars, electric pleasure cars, commercial cars, motor cycles and accessories. The committee which will have charge of the show has established offices at 911 Floyd Building.

## St. Louis Dealers Announce Show

ST. LOUIS, Nov. 6—A two-week automobile show is announced for St. Louis Feb. 5 to 17 at the Coliseum, by the same dealers who participated in the show held there last Winter. This will make the second exhibit to be given in St. Louis this season, an open air show having been successfully carried through early in October.

The coming exhibit, like those of Chicago and New York, will be divided into two parts. The first week will be devoted to the display of pleasure cars and accessories, and the second week to motor trucks. This will be the first time a two-week exhibit has been tried in St. Louis, and also will be the initial exclusive truck display.

## Omaha's Show Ideas Expanding

OMAHA, Nov. 6—The annual meeting of the Omaha Automobile Show Dealer's Association was held last week. It was decided to hold the automobile show some time in the latter part of February. In previous years the show has been held at the auditorium and the dealers have been cramped for space. This year the association is planning to hold the show at the Coliseum, the home of the Knights of Ak-Sar-Ben of Omaha. The floor



space in the Coliseum is about double that of the other building, although it is not so centrally located. Twelve new members were admitted to the association.

The following officers were elected: J. J. Deright, president; J. T. Stewart, vice-president; Clark G. Powell, secretary and treasurer. The board of directors includes the officers and Guy L. Smith and Denise Barkalow. Mr. Powell will be manager of the show again.

### Hoosiers to Hold a Fall Show

INDIANAPOLIS, IND.—Arrangements are being made by the Indianapolis Automobile Trade Association for a motor show to be held Nov. 20-25, the first Fall show Indianapolis has ever had. Fred I. Willis, who recently became identified with the Kokomo Rubber Co., Kokomo, has asked to be relieved of his duties as president of the association, and Harry A. Archey, first vice-president, is presiding over the club. It is probable that the association members, during the show, will furnish cars for a free bus service to carry visitors to and from the various salesrooms. Each dealer will exhibit in his own establishment.

The association has adopted a resolution against the lending of cars for any purpose, charitable, or otherwise, unless the proposed lending is passed on favorably by the directors. Another resolution adopted provides that all requests for contributions or advertising for programs, or other things not directly identified with the motor car trade shall be referred to the association's secretary for recommendation.

### Exhibition Planned for Baltimore

BALTIMORE, MD., Nov. 6—While no definite plans have been made, the Automobile Club of Maryland and the Baltimore Automobile Dealers' Association are working on the proposition and expect to announce show dates in the near future.

It is known that either the middle or latter part of February is favored, but those having charge of the affair in both associations do not care to decide on any definite date until they are sure that the time they select will not conflict with the shows in New York, Chicago, Philadelphia and other large cities. A general meeting of the Dealers' Association will be held in the near future.

## Optimism in Industry at Detroit

**D**ETROIT, MICH., Nov. 6—Following a most satisfactory October, November has come in full of promise for the local motor industry. Some of the manufacturers are already beginning to predict that 1912 will be the greatest year in the history of the business, in spite of the presidential election and the business disturbance that almost inevitably accompanies such an event.

Hugh Chalmers, president of the Chalmers Motor Company, in a talk before the men in attendance at the Chalmers technical convention last week, expressed the belief that 1912 would set a new record for sales of motor cars. For the first four months of the 1912 season the company's shipments show an increase of 35.3 per cent. over the same period last year. The factory is being operated up to its full capacity, working both day and night shifts.

The Chalmers technical convention will end this week. The attendance will not be confined to men from any one section, but service men from all parts of the country, who have not been able to come earlier, will take advantage of this opportunity to see just how Chalmers cars are made and to get into closer personal touch with the makers. The convention has been a great eye-opener for some of the visitors, and the company feels that the results achieved more than compensate for the monetary outlay.

The Ford Motor Company reports that it manufactured and sold nearly 4,000 cars during October. The output will be greatly increased, it is expected, when the new addition, now rapidly nearing completion, is put in operation early in December. The company is hopeful of breaking even the record of last May, when 6,013 cars were shipped, before the Winter is over.

That the other Detroit makers are sharing in this prosperity is shown by the extensive building operations under way. Mention has previously been made of several of the new plants and additions under construction, but of the building of motor car factories there seems to be no end, in this city at least. Work has been begun on a new garage for the Hupp Corporation at Jefferson avenue and Gilbert street, in the Fairview district, just two blocks from the company's plant. The building will be ready for occupancy about January 1. It will be used for displaying and storing R. C. H. cars. The garage will be 62 x 125 feet and will be a very ornamental structure.

A tract of land comprising 100 acres at Woodward avenue

and the 9-mile road has just been purchased by Walter C. Piper, and it is understood that half of the property will be used as a site for a monster automobile plant, the remainder being subdivided into lots for the employees. It is not known, as yet, what company intends building here. The price paid for the land was about \$85,000.

The Detroit Bi-Car Company has been organized with a capital of \$100,000, to manufacture the "Bi-Car," which is described as a motorcycle embodying some of the features of an automobile. It is driven by a four-cylinder, four-cycle engine, started by a crank at the side. It has two speeds and a neutral, operated by a regular shaft drive. The company has established a temporary factory at Greenwood and Baltimore avenues, but plans to build later. The officers are: President, John J. Chapin, who is also the inventor of the machine; vice-president, Alfred Roseroot; secretary, John J. Berkery; treasurer, Frank J. Gorman.

The Wolverine Automobile Club is making arrangements for its third under-sealed-orders run next Sunday, the officials having mapped out the route yesterday. The trophy for this run will be donated by Robert K. Davis, of the United Motor Detroit Company. C. A. Smith, driving a Hupmobile, was the winner of the second run, a week ago. He came within 4 minutes of the official time, which was 6 hours and 39 minutes, an average of 13.28 miles per hour.

### Atlanta Dealers Win a Home

ATLANTA, GA., Nov. 6—The Atlanta Automobile Dealers and Accessory Association has won itself a home. It accomplished this feat by amalgamating with the Transportation Club in a new organization which will be known as the Atlanta Auto-Transportation Club.

The full breadth of the scheme that the dealers' association is working on has not appeared in the newspapers yet, but it is planned within the year to absorb the Transportation Club entirely and to make a straight automobile dealers' club out of the affair. With Atlanta the center of the automobile business in the South the dealers have long felt the need of some place of their own where they could entertain guests, meet to transact business and thus preserve an active organization.



## NEWS of the WEEK CONDENSED

**BUFFALO, N. Y.**—The new plant of the Victor Motor Truck Company is being built on a large plot of ground secured by the company on the Military Road and alongside the New York Central Railroad. The new building will possess all the advantages essential to efficient production of the various types of trucks made by the company. These include commercial trucks of from 1,500 pounds capacity to 10 tons capacity, and fire trucks of the combination hose wagon, pumping and hose and ladder and hose types.

**Buenos Ayres, S. A.**—Prudencio Trejo has taken the agency for the Pullman cars.

**BUFFALO, N. Y.**—A. W. Meyer has taken the agency for the 1912 line of Pullman cars in Buffalo and northern New York.

**LANSING, MICH.**—The Olds Motor Works, of this city, has commenced to operate some of its departments thirteen hours a day.

**KANSAS CITY, Mo.**—W. R. Griffin, of Stockton, Kas., has made arrangements with the Cole Motor Car Company, of this city, to handle the Cole 30-40.

**PONTIAC, MICH.**—With the final installment of machinery in the big A plant of the Flanders Manufacturing Company, the turning out of Flanders electrics will begin shortly.

**GRAND RAPIDS, MICH.**—Slootmaker Brothers will soon open their new garage on Madison square, at the head of Crawford street, where they are erecting a large cement building.

**BOSTON, MASS.**—Louis B. Adams, one of the best known newspaper men in New England, has just accepted a position with

Harold D. Bornstein, of the Velie Boston branch, in the sales department.

**FLINT, MICH.**—The production of the 34 and 35 models of the Buick Motor Company for 1912 is steadily increasing. It is expected to increase the average daily output to fifty. The plant is now employing 3500 men.

**PHILADELPHIA, PA.**—The Pullman Automobile Company of Philadelphia has been formed by Pullman owners who will handle that line in the Quaker City and the surrounding territory, including part of New Jersey and Delaware. Harry Grant is president of the company.

**SAN FRANCISCO, CAL.**—The Flanders electric is to be handled in Northern California by the Pioneer Automobile Company, which also distributes the Chalmers cars. The company has also taken the agency for the R. C. H. car.

**DENVER, COL.**—J. A. Fry, for many years branch manager for Apperson Brothers in Chicago, and until recently connected with the Fry & McGill Auto Supply Company, of this city, has assumed the position of manager of the sales department for the Everitt branch in Denver.

**FRESNO, CAL.**—The San Francisco-Fresno record has been broken by a Warren "30" car, driven by Columbus Hobson of this city. The official time was 5 hours, 42 minutes and 30 seconds, the old record being 7 hours and 17 minutes, which had stood undisturbed for five years.

**DENVER, COL.**—The Goodyear Tire and Rubber Company has opened a handsome new store at 1562 Broadway. The furniture and fixtures are of white oak and an indirect lighting system makes a brilliant

display at night. The branch now has four local and two traveling salesmen.

**YORK, PA.**—The Pullman Motor Car Company, of this city, announces that, in addition to its line of pleasure cars, it will build taxicabs in the future. The first taxicabs built by the company, a shipment of twenty-five, were sent to the Pullman Taxicab Company, of Philadelphia, last week.

**DETROIT, MICH.**—Marburg Brothers, importers of the Mea high-tension magneto and S. R. O. ball bearings, have opened a branch office in this city. Mr. Roy J. Taylor, well known in the automobile circles of this vicinity through his connection with manufacturers here, has been appointed manager.

**HARVEY, ILL.**—The Buda Company has arranged with Brandenburg & Company, located at 1108 South Michigan avenue, Chicago, Ill.; Fifty-seventh street and Broadway, New York City, N. Y., and Ford Building, Detroit, Mich., to sell their products, consisting of motors, transmissions and other parts for automobiles.

**EMPIRE, ORE.**—Mr. and Mrs. Ralph Barker have successfully completed their strenuous Coast-to-Coast run in their light delivery Reo motor truck. A few months ago Mr. and Mrs. Barker went by train from Empire to their old home in New England, and while there purchased the truck for their return trip. They left Stratham, N. H., August 10, provided with a touring cover forming a regular living room. With this was included a complete camping outfit, which permitted them to pitch their tent whenever and wherever they pleased.

**CRIPPLE CREEK, COL.**—The Cripple Creek Automobile Company has recently opened a new garage at 140 East Bennett avenue.

**COLUMBUS, OHIO**—Frank J. Girard, 174 North Fourth street, Columbus, Ohio, has taken the agency for the R. C. H. in 20 counties in central Ohio.

**CLEVELAND, OHIO**—F. H. Meyers, for many years in the employ of the Standard Welding Company, has been appointed to the office of assistant superintendent.

**MILWAUKEE, WIS.**—The Gas Power Engineering Company, Third and Wright streets, Milwaukee, has been appointed distributor for the Premier car. The company operates a large garage.

**ELMIRA, N. Y.**—Incorporation papers for the Elmira Automobile Club have been filed in the County Clerk's office. Incorporators, M. Doyle Marks, Arthur Clinton, Frank E. Robbins, Melvin R. Elis and others.

**COLUMBUS, OHIO**—The Hudson Sales Company, North Fourth street, Columbus, Ohio, has taken the agency for the Buick for 1912 in Franklin and Licking counties, Ohio. A sub-agency will be established at Newark, Ohio.

**COLUMBUS, OHIO**—The Cummins Auto Sales Company of 153 North Fourth street, Columbus, Ohio, has taken the central Ohio agency for the K-R-I-T for 1912. The territory includes six counties in the central part of the state.

**WASHINGTON, D. C.**—A change has been made in the Lozier agency here and the 1912 line of cars will, in the future, be

handled by the Lozier Sales Company, of 1315 H street, N. W., this company having been formed exclusively for the purpose.

**SAN FRANCISCO, CAL.**—The Stanley Steam Car Company has been organized to handle the well-known steam car of that name in Northern California. L. H. Austin and R. C. Bennett, prominent Bakersfield men, are the organizers of the company.

**DETROIT, MICH.**—J. R. Hall, for five years manager of the Service Department of the eastern district branch of the Lozier Motor Company in New York City, has been appointed to the position of manager of the Service Department of the Lozier Motor Company in this city.

**MILWAUKEE, WIS.**—The City of Milwaukee, which owns sixteen motor cars, is considering the purchase of six more. Three will be for the use of assistant chiefs of the fire department, two for the health department and one for the consolidated police and fire alarm signal service.

**PHILADELPHIA**—The Mercer Automobile Company, of Trenton, N. J., has taken the distribution of its cars out of the hands of agents and in future it will be conducted through a branch house which has just been established at 620 North Broad street. W. A. Smith, formerly business and advertising manager of *Automobile Topics*, has been placed in charge as branch manager.

**AKRON, OHIO**—In a decision handed down recently the circuit court sustained the common pleas court in finding Earl

Sprankle of Akron, Ohio, guilty of manslaughter in running down and killing Helen Starr with an automobile which Sprankle was driving. Sprankle was found guilty in the criminal court and sentenced to the Mansfield Reformatory. The case may be carried to the Supreme Court.

**INDIANAPOLIS, IND.**—The formal opening of the bus service of the Rapid Motor Transit Company in Indianapolis took place on November 1. There are seven cars, six of which are in continual service from 6.30 A. M. to 11.15 P. M. daily, while the seventh is used during the rush hours. Entrance is at the front of the right hand side and the pay-as-you-enter system is employed, the driver collecting fares as passengers enter.

**INDIANAPOLIS, IND.**—A number of changes have taken place in the local trade. The Case factory sales branch has been moved from North Capitol avenue to 241 Kentucky avenue. A. W. Ellis, city salesman for the Goodyear tire sales branch, has become manager of the Louisville branch. Frank Staley has become Indiana distributor for the R. C. H., with headquarters at 513 North Capitol avenue. A factory sales branch of the Schact Motor Car Co., Cincinnati, O., has been opened at 328-330 North Delaware street.

**LOS ANGELES, CAL.**—The Alfred C. Stewart Machine Works has disposed of its United States rights to the Detroit Lubricator Company, of Detroit, Mich., which company will be turning out the Stewart Carbureter within the next two or three months.

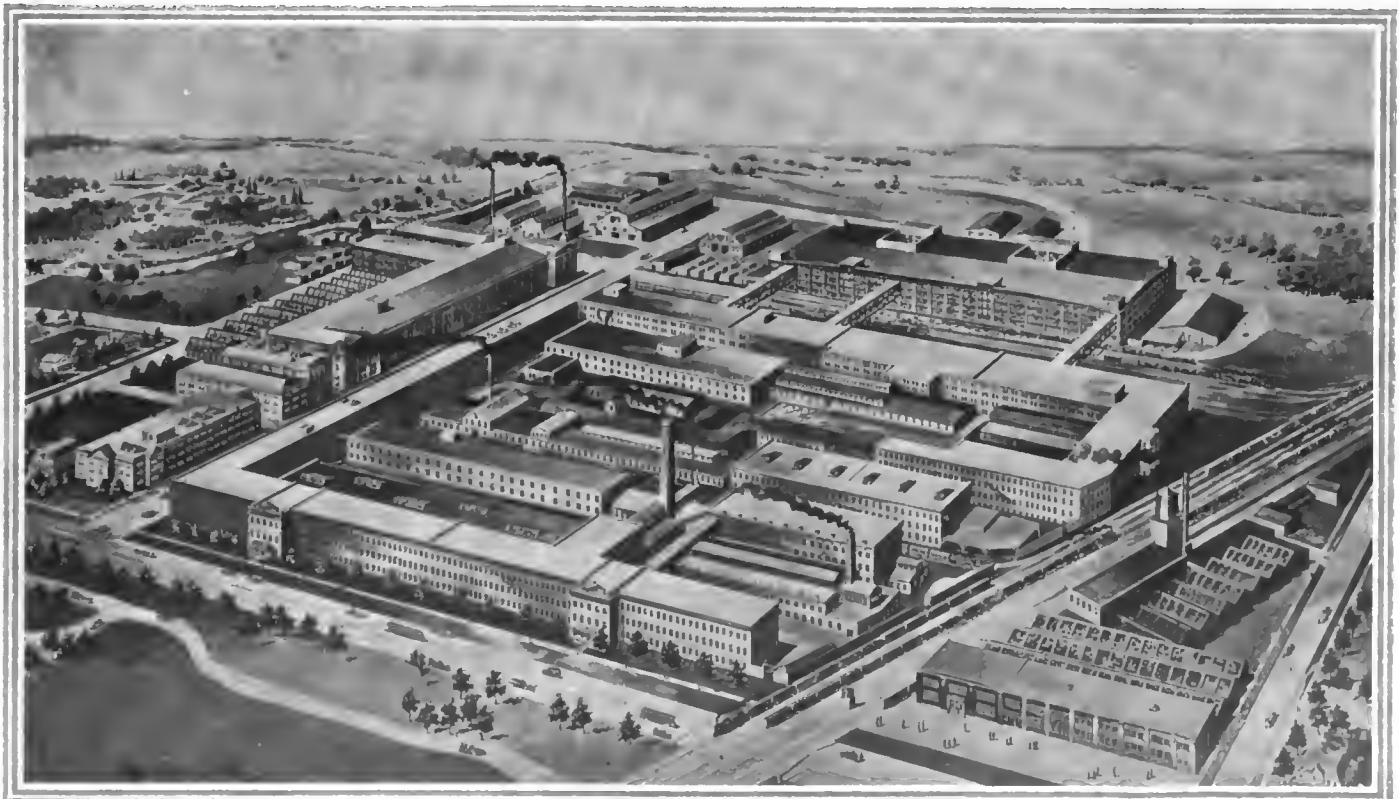

Bird's-eye view of the enlarged Willys-Overland plant at Toledo, Ohio—new body-building, trimming and paint department building in background



Three-ton Packard truck used in farm work in Connecticut

CLEVELAND, OHIO.—The Lozier Motor Company has moved into its new quarters at 6402-4 Euclid avenue.

OMAHA, NEB.—J. A. Longyear, of South Bend, Ind., has recently joined the retail sales force of the Omaha branch of the E-M-F Company.

BOSTON, MASS.—The Malley Motor Vehicle Company, agent for the Warren car, is to handle the Flanders Electric in Boston and vicinity.

BALTIMORE, MD.—The Oakland Sales Company, representatives of the Oakland car and Federal truck in this city, has moved to its new quarters on East Chase street.

SAN FRANCISCO, CAL.—The Pioneer Automobile Company has taken the agency for the Flanders Electric car. R. H. Morris will be in charge of the company's electrical department.

BOSTON, MASS.—F. L. Sanford has joined the sales force of the Henley-Kimball company and has been given charge of the wholesale department for outside territory on Hudson cars.

NEW YORK CITY.—The Mitchell-Lewis Motor Company, of Racine, Wis., has opened a branch house at 1855 Broadway and a new service building on Fifty-first street, west of Broadway.

SYRACUSE, N. Y.—I. W. Reid has resigned as comptroller of the Franklin Automobile Company. His plans for the future are undecided. B. E. Snyder, head accountant, has assumed Mr. Reid's duties.

BOSTON, MASS.—The new Alco branch is now located in Copley Square with George M. Hudson as manager and has leased quarters in the big Shoe & Leather building in Cambridge for a service department.

MONTREAL, CAN.—The Canada Auto & Taxi Company, of this city, announces that, to comply with the ever-increasing demand for taxicabs, they have decided to reduce

their fares by one-half during business hours.

CLINTON, ONT.—The town of Clinton voted to-day to sell a partly equipped plant and to give a fixed assessment to the Clinton Motor Car Company, which consists of Toronto capitalists and local manufacturers.

BOSTON, MASS.—The Selden car and the Mais truck, formerly handled in this city by W. S. Jameson on Boylston street, are now being marketed by R. L. & H. L. Smith & Company with offices at 1008 Commonwealth avenue.

BOSTON, MASS.—The J. W. Maguire Company, agent for the Pierce Arrow car in eastern Massachusetts, has secured a lease of the premises next door to its present site, giving it one of the largest sales-rooms on Boylston street.

NEW YORK CITY.—The various articles of automobile clothing used in connection with the illustrations for "Comfort in Winter Driving," in our issue of November 2, were from the establishment of the Auto Supply Company, 1789 Broadway, New York City.

SYRACUSE, N. Y.—The Franklin Automobile Company's local business will be handled hereafter at the factory in South Geddes street. More ample display facilities are afforded, while the repair work can be better handled in the factory repair department.

UTICA, N. Y.—The Oneida Garage Company will soon erect one of the finest garages in this section of the State at 215 Park avenue. The officers of the company are Frank Bowen, president; H. T. Powell, secretary and treasurer, and George A. McCracken, general manager.

DETROIT, MICH.—Hal Reifenberg, manager of the Warner Instrument Company's branch house at Kansas City, Mo., has been put in charge of the company's branch house in this city, succeeding A. S. Koto,

who has resigned. Mr. Reifenberg's successor has not yet been announced.

LOUISVILLE, KY.—Arthur W. Ellis, of Indianapolis, is the new manager of the local branch of the Goodyear Tire & Rubber Company. He succeeds Robert B. Harbison, who has resigned. James B. Williams, of Harrodsburg, has been chosen to fill the position of office manager, formerly held by Robert Grabill.

CLEVELAND, OHIO.—Mr. Frank L. Sessions has been appointed to the office of superintendent of the Standard Welding Company. Mr. Sessions is a graduate of Worcester Polytechnic Institute, 1889, a member of the American Society of Mechanical Engineers and of the American Society of Electrical Engineers.

FRESNO, CAL.—The Warren-Detroit car, which won the silver cup in the recent endurance run from San Francisco to Los Angeles and return, also broke the road record between San Francisco and Fresno. The official time was 5 hours, 42 minutes and 30 seconds, the former record was 7 hours and 17 minutes.

NEW YORK CITY.—J. R. Hall, for five years manager of the service department of the Eastern district branch of the Lozier Motor Company here, has been appointed manager of the service department of the Lozier Motor Company of Detroit, Mich. Mr. Hall has been identified with the Lozier interests for more than twenty years.

ATLANTA, GA.—So vigorous has been the competition for desirable situations for automobile agencies in Atlanta that they are becoming hard to find. The Locomobile Company of America has not as yet been able to locate its Atlanta Branch and is still occupying desk room at 230 Peachtree street. The company will soon open its own place.

INDIANAPOLIS, IND.—Kark Feilcke, chief designer and engineer of the Motor Car Manufacturing Company of this city, sailed from New York last week to attend the Olympia show in London, thence proceeding to the Continent, where he will investigate any new ideas of the European manufacturers. He will return early in January to attend the New York show.

GREENWICH, CONN.—Conyers' Farm covers 1,600 acres in this State and a small tract in New York State. It is famous for its apples, of which this year's harvest totaled 3,500 barrels. The work about the farm is so heavy and continuous that a 3-ton Packard truck is in constant use doing the heavy hauling. Much of the work of the truck consists in transporting the farm products to this place, fully 7 miles distant. During portions of the year the truck is kept in constant service for 20 hours out of the 24, and it has been proven time and again that it can make three trips while the horse-drawn teams used on the farm are making one.



WASHINGTON, D. C.—Colonel George Schutt has returned from a 4,500-mile trip to Omaha, Neb.

MILWAUKEE, WIS.—The Spring Bearing Truck Company has increased its capital stock from \$10,000 to \$20,000 to care for extensions of the business.

HAZLETON, B. C.—After a gruelling trip, replete with adventure, the Flanders Pacific Highway pathfinder successfully completed the rail-blazing run from Seattle, Wash., to this city.

BERLIN, GERMANY—Because cattle do not mind a little noise like the tooting of an automobile horn a German manufacturer has added folding whips to the equipment of his cars.

INDIANAPOLIS, IND.—Charles Lacy, of Buffalo, has taken charge of the repair shop at the local branch of the Buick Motor Company. Mr. Lacy has had great experience in automobile repair work in the East.

WASHINGTON, D. C.—The Lozier Sales Company has been formed to handle the Lozier here. W. M. Giesey, formerly of Pittsburg, will be the manager. The salesroom has been located at 1315 H street, N. W.

WASHINGTON, D. C.—The Pope Automobile Company, agent for the Pope-Hartford and the Columbus Electric, has been appointed agent for the Marathon in the District of Columbia, Maryland, Virginia and West Virginia.

WASHINGTON, D. C.—Miller Brothers, one of the oldest motor cars firms here, and who have handled the Ford and Velie for a number of years, have relinquished the agency for the latter make. Several firms are negotiating for the Velie agency.

RICHMOND, VA.—The Virginia Taxicab Service Company, of this city, has instituted suit for damages to the sum of \$45,000 in the Law and Equity Court against the Sultan Motor Company and the Otis Elevator Company. No declarations have as yet been filed.

SAN FRANCISCO, CAL.—Two new automo-

bile agencies have invaded San Francisco the past week, the Bergdoll and Colby machines. Ben R. Savannah has the agency for Northern California on these two new cars and will shortly appoint sub-agents throughout the interior of California.

MILWAUKEE, WIS.—The Milwaukee and Wisconsin agency for the Packard, held by Welch Brothers Motor Car Company, has been supplanted by a direct factory branch which will be located in the present Packard garage. O. G. Heffinger, sales manager for the Welch Brothers company, becomes general manager, and the tech-

nical management continues in the hands of H. W. Liddle. R. C. Chidester will be sales manager.

STEVENS POINT, WIS.—The Central Wisconsin Motor Show was held here by the Auto Sales Company to celebrate the opening of its large garage. The company handles the Cadillac, E-M-F, Flanders Buick, Stoddard-Dayton, Overland and Rambler. Dr. J. W. Bischoff, a well-known physician and one of the earliest motorists of the State, is at the head of the concern. The Mayor and other notables made addresses each night.

## Automobile Incorporations

### AUTOMOBILES AND PARTS

BOSTON, MASS.—Vera Motor Car Co.; capital, \$60,000; to manufacture automobiles. Incorporators: G. M. Polani, A. M. Sweeney.

BRADFORD, PA.—Bradford Auto Exchange; to make automobiles and parts. Incorporators: F. H. Reed, J. I. Holmes, F. H. Deagan, S. L. Tibbits, F. D. Gallop.

BUFFALO, N. Y.—International Automobile League Tire & Rubber Co.; capital, \$1,000,000; to manufacture tire casings and inner tubes.

BROOKLYN, N. Y.—Finlay Automobile Co.; capital, \$10,000; to sell automobiles. Incorporators: William Finlay, Joseph School, Ernest Finlay.

DETROIT, MICH.—Detroit Bi-Car Co.; capital, \$100,000; to manufacture automobiles. Incorporators: John J. Chapin, Alfred Roseroot, John J. Berkery, Frank J. Gorman.

EVANSVILLE, IND.—F. W. McNeely & Co.; capital, \$25,000; to deal in automobiles. Incorporators: Chester Rankin, F. W. McNeely, Alice McNeely.

ERIE, PA.—Stirling Brothers Co.; capital, \$15,000; to sell automobiles. Incorporators: Alex Stirling, John Stirling.

FREDERICKSBURG, VA.—Fredericksburg Motor Co., Inc.; capital, \$10,000; to conduct a general automobile business. Incorporators: L. R. Colbert, Alvin T. Embrey, H. C. Biscoe.

KNOXVILLE, TENN.—Stewart Automobile Co.; to deal in motor cars. Incorporators: R. G. Stewart, E. F. Ferry, L. Lemay, Mrs. S. Stewart, Mrs. Nellie Blankenship.

NEW CASTLE, IND.—Whitesides Commercial Car Co.; capital, \$31,250; to manufacture freight automobiles and parts. Incorporators: F. N. Whitesides, O. S. Saffert, O. O. Carpenter.

NEW YORK CITY.—Hatch Oil Engine Co.; capital, \$100,000; to manufacture engines and machinery. Incorporators: C. W. Hatch, W. P. Hatch, Jr., A. Anderson.

NEW YORK CITY.—International Motor Service Association; capital, \$100,000; to manufacture automobiles. Incorporators: Wm. H. Brearley, Walter W. Friend, Irene A. Monsees.

PORTLAND, ME.—Hamlin-Foster Co.; capital, \$100,000; to manufacture automobiles. Incorporators: Arthur D. Hamlin, Albert S. Ventrea, Charles C. Briggs.

RIDGE, N. J.—Stark Auto Co.; capital, \$10,000; to deal in automobiles. Incorporators: Jacob H. Stark, Harry S. Stark, Robert A. Sibbald, Frank O. Mittag.

SANDUSKY, OHIO.—Sandusky Auto Parts Co.; increased capital stock to \$500,000.

WILMINGTON, DEL.—Eastman Motor Truck Co.; \$25,000; to manufacture freight automobiles. Incorporators: J. H. Sbeidis, C. E. Semmes, H. G. Eastburn.

WOODSTOCK, ONT.—Woodstock Automobile Mfg. Co., Ltd.; capital, \$50,000; to build automobiles. Incorporators: Alexander C. Applebaum, Herbert H. Thorpe, H. F. Græne.

### AUTOMOBILE GARAGES AND ACCESSORIES

AKRON, OHIO.—Diagonal Block Tire Co.; capital, \$25,000; to make automobile and motorcycle tires and other rubber goods. Incorporators: J. A. Swinehart, W. R. Talbot, Frank R. Talbot, A. L. Siegrist, W. H. Graham.

BROOKLYN, N. Y.—Agotaras Garage Co.; capital, \$10,000; to sell, repair and store motor vehicles. Incorporators: Wm. R. Hoffman, Leonora Klingler, John Bahr.

BUFFALO, N. Y.—Frontier Tire & Rubber Co.; capital, \$250,000; to manufacture pneumatic tires. Incorporators: George B. North, Howard N. Gill, Franklin D. L. Stowe.

CLEVELAND, OHIO.—Cleveland Welding & Mfg. Co.; capital, \$150,000; to manufacture rims and other welded products. Incorporators: E. I. Heinesohn and others.

CHICAGO, ILL.—General Auto & Repairing Co.; capital, \$25,000; to conduct a general garage and taxicab business. Incorporators: W. R. Potter, George H. Davis, Frank H. T. Potter.

NEW ORLEANS, LA.—Hercules Tire Co.; capital, \$50,000; to manufacture tires and rubber goods. Incorporators: J. M. Underwood, Sam J. Connell and others.

NEW YORK CITY.—City Taxicab Co.; capital, \$10,000; to conduct a taxicab business. Incorporators: Arthur J. Smith, Wm. Oakford, F. M. Oakford.

NEW YORK CITY.—G. & Accessory Co.; capital, \$100,000; to make and sell automobile supplies. Incorporators: F. D. Glover, J. G. Stuart, J. Z. Lowe, Jr.

NEW YORK CITY.—The Service, Inc.; capital, \$100,000; to conduct a general agency relative to automobile trade, collections, etc. Incorporators: D. M. Hooks, T. B. Nisbet, F. C. Carr.

NEW YORK CITY.—Teven Garage Co.; capital, \$10,000; to conduct a garage business. Incorporators: Joseph C. Graveur, Martha Graveur, Ross Teven.



Ending of the parade in honor of the Maxwell Glidden winner, at the United States Motor Company building, New York City



# OF INTEREST *to the* INDUSTRY



Atlanta police with their new Cole service car meet Gliddenites

**ATLANTA, GA.**—The police of Fulton County, in which this city is located, have long felt the need of an automobile in their work. Two weeks ago a 1912 Cole 30-40 car was purchased for them and, by a happy coincidence, the first duty it was called upon to perform was to meet the incoming Glidden Tour and guide it into and through Atlanta.

**AKRON, OHIO.**—A. G. Partridge has been appointed assistant sales manager of the Firestone Tire & Rubber Company.

**FORT WAYNE, IND.**—At the annual meeting of the stockholders of the Ideal Auto Company it was unanimously voted to increase the capital stock from \$50,000 to \$100,000.

**PITTSBURG, PA.**—Reports received here from the capitals of many States show that in two years the number of women drivers of automobiles have increased more than three times over.

**COLUMBUS, OHIO.**—The contract has been awarded for a large addition to the plant of the John W. Brown Manufacturing Company of Columbus, Ohio, makers of automobile lamps and other accessories.

**SUMTER, S. C.**—L. A. Prince, of the Ohio Motor Car Company, of Cincinnati, Ohio, has taken the managership of the Ohio Sales Company of South Carolina. He will operate a vulcanizing plant in connection with this.

**RIO DE JANEIRO, BRAZIL.**—More than a dozen large manufacturers of American motor cars have sent representatives with demonstrating machines to this city in the past month to take advantage of the great boom in the automobile industry.

**MILWAUKEE, WIS.**—David Van Alstyne, vice-president in charge of the manufacturing department of the Allis-Chalmers Company, has sent in his resignation, to take effect November 15. C. E. Search, formerly Mr. Van Alstyne's assistant, has been appointed works manager.

**BIRMINGHAM, ALA.**—The H. W. Johns-Manville Company have found it necessary, owing to increasing business, to change the location of their office from 1220 Empire Building to 606 Chamber of Commerce Building. The office will continue under the management of W. H. Fleming.

**NEW YORK CITY.**—The balance of trade in motor cars continues to grow in favor of the United States. Besides the gain in exports, in the first eight months of 1911 there were imported 608 cars valued at \$1,312,969, against 723 cars valued at \$1,443,871 in the corresponding period of the preceding year.

**COLUMBUS, OHIO.**—T. A. Sawyer has purchased the business of the Monnett Brass Company, located at 621-2 East Spring street, Columbus, Ohio, and has changed the name to that of the Sawyer Auto Brass & Specialty Company. The concern will continue the business of making accessories and parts for motor cars.

**INDIANAPOLIS, IND.**—Directors of the Whitesides Commercial Car Co., recently reorganized, and which is moving from Franklin, Ind., to Newcastle, Ind., have elected the following officers: President, O. W. Saffell; vice-president, F. M. Whitesides; secretary and general manager, C. W. Boyd, and treasurer and factory manager, J. W. Prigg.

**MUNCIE, IND.**—Thomas J. Heller, formerly sales manager of the Standard Roller Bearing Company, has joined the forces of the Warner Gear Company as Eastern factory representative, with headquarters at Glenwood avenue and Second street, Philadelphia. Mr. Heller will handle the Eastern sales end of the company, whose product comprises pleasure and commercial car transmissions, steering gears, control levers, clutches and differentials. Mr. Heller is well known to the automobile trade.

**DETROIT, MICH.**—The Lavinge steering gear, formerly manufactured by the Lavinge Mfg. Co., has been taken over into a new corporation, known as the Lavinge Gear Co. The new company has been organized with a capital of \$100,000, with offices at Detroit and Milwaukee. In addition to the Detroit plant, they will operate a larger plant for the manufacture of the steering gear exclusively at Corliss, Wis., a suburb of Milwaukee. Joseph P. Lavinge, inventor and designer of the steering gear, will remain with the company as chief engineer.

**NEW YORK CITY.**—Montgomery Hallowell, general advertising manager of the United States Motor Company, has resigned to join the forces of the H. E. Lesan Advertising Agency, where he will assist in the handling of the United States Motor Company advertising and in the broadening work of the Lesan Agency, a work for which, by long experience, he is eminently qualified. Gridley Adams has been appointed to succeed him. Mr. Adams has been advertising manager of the Stoddard-Dayton division of the United States Motor Company and is well known in the advertising field.

**COLUMBUS, OHIO.**—The Union Sales Company of Columbus, Ohio, is backing the organization of what will be styled the Union Motor Car Company, which will manufacture a new line of motor cars to be known as the Union "25." The work of manufacturing has been started at the plant of the Dunlap Engineering Company, 1436 Parsons avenue. J. W. O'Brien, of Nashville, Tenn., who is at the head of the Union Sales Company, announces that contracts have been signed for 5,000 parts and it is proposed to build at least 200 cars during the coming season. Only one model will be made and that will be a two-seated runabout which will sell for \$650 or \$700, equipped with windshield, lamps, speedometer, top, generator and trunk. The offices of the company are located at 61 East Spring street and the marketing of the product will be done by the Union Sales Company.

# PATENTS GONE TO ISSUE

**INTERNAL COMBUSTION ENGINE**  
—In which flow of gases is regulated by an oscillating valve.

3. The patent (Fig. 1) covers the combination with a cylinder having an inlet and an exhaust port, of an oscillating valve pivoted therein at one end of its body portion, controlling both the exhaust and inlet ports, and means for producing oscillation of said valve.

No. 1,007,491—To Robert A. Reynolds, Detroit, Mich. Granted October 31, 1911; filed March 15, 1909.

**ROTARY ENGINE**—Combining the principles of cylinder and rotary piston.

5. This engine contains a cylinder in which operates a rotary piston. In the latter is slidably mounted a device which has diametrically opposite blades. An abutment is slidably mounted in a cylinder and co-acts with the piston, it being urged inwardly by a spring. A cam projects into the cylinder and is disposed in the path of the blades, causing one blade to move inwardly and the opposite blade to move outwardly. Means are provided for conveying a charge into the cylinder on one side of the abutment, while on its opposite side means for igniting are located. As the blade passes and pushes the abutment outwardly a charge may be admitted into the cylinder under pressure.

No. 1,007,100—Bert H. Harris, Goldhill, Oregon. Granted October 31, 1911; filed May 6, 1910.

**ACETYLENE LAMP**—A combination of acetylene generator and light.

1. This patent (Fig. 2) refers to the combination of an acetylene lamp with a carbide reservoir having a cap on which is mounted a water receptacle, with a burner extending from the cap and a block of fibrous material covering the inner end of the burner. To the under side of a metallic plate is secured a section of cork adapted to close the opening of the carbide reservoir with the plate resting upon the edge of

the reservoir opening. Cork and plate have a number of conical openings for the passage of gas from the reservoir to the acetylene burner, fibrous material being loosely packed in the openings.

No. 1,007,374—To Anton H. Mollman, Jr., Hillsboro, Ill. Granted October 31, 1911; filed December 31, 1910.

**CLUTCH**—Containing in its make-up a bearing and races.

5. In this clutch (Fig. 3) a bearing race with revoluble bearing members is interposed between the driving and the driven members, wedging members being adapted to be projected against the bearing members to wedge the same in their race. A ball is mounted over each of the wedging members and axially movable clutch members are provided which, when moved together, exert pressure on the balls, whereby the wedging members operate to wedge the revoluble bearing members in their race.

No. 1,007,139—To Bertram H. Penn, London, England. Granted October 31, 1911; filed October 8, 1910.

**CARBURETER**—Spreader members are used to obtain good mixing effect.

3. This carbureter (Fig. 4) comprises a casing with an inlet of the bottom and an outlet at the top. To control the outflow of mixture from the casing a throttle is provided and a supply connection extends to the casing and is provided with a valve seat and spreader member. With the valve seat co-operates a valve member to which is connected a movable spreader member co-operating with the fixed spreader member. Thus an annular outlet is formed between the two members and means are provided for yieldingly supporting the valve member and the movable spreader so as to allow the same to be opened by the suction through the casing. The opening movement of the valve is limited. Means are provided to operate the throttle and at the same time limit the movement of the valve.

thereby allowing increased opening of both valve and throttle.

No. 1,007,659—To Merrill B. Rice, Los Angeles, Cal. Granted October 31, 1911; filed October 25, 1910.

**VEHICLE TIRE**—A pneumatic tire in which the rubber canvas body is reinforced by an armor fabric.

The tire protected by this patent comprises a casing, a reinforcing for this casing, including a canvas fabric body suitably disposed and incorporated within the casing, an armor fabric imbedded in the casing and extending into the heel portions of the same and disposed above the reinforcement mentioned. Hooked portions are formed on the termination of the side portions of the armor fabric, and a second armor is embedded and vulcanized in the tire casing and disposed above the first armor fabric, the second armor being V-shaped in cross-section with inclined sides formed thereby to ward off any sharp point which might pierce the casing, and hooked portions formed at the termination of the sides to securely anchor the second armor.

No. 1,007,018—To Harry Wilson and Carl Guder, McKeesport, Pa. Granted October 24, 1911; filed July 12, 1911.

**PIPE JOINT**—Being of a universal ball-and-socket type.

This joint comprises two tubular sockets, one of which fits into the other. Into the center of axis of one socket a hub is mounted, and co-axial with it another hub in the other socket. One of the hubs carries a bolt secured against longitudinal displacement in the hub. The bolt has a head and around it is fitted a sleeve which bears with a spherical edge against a spherical depression of the hub carrying the bolt. The sleeve has a spherical depression for the bolt head to rest upon and is connected to hub and not carrying the bolt.

No. 1,007,362—By Johann Koenig, Riga, Russia. Granted October 31, 1911; filed May 27, 1911.

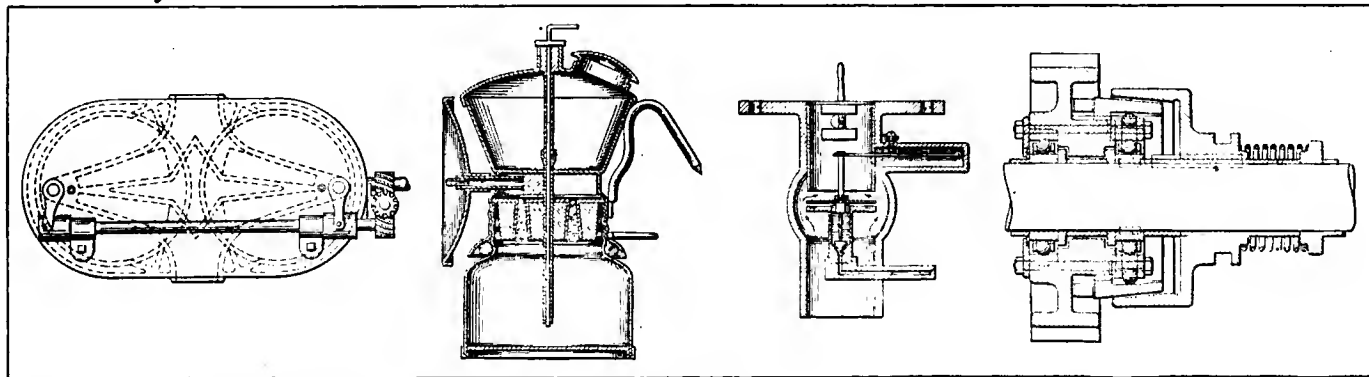

Fig. 1—Reynolds motor. Fig. 2—Mollman acetylene light. Fig. 3—Penn clutch. Fig. 4—Rice carbureter

# Newest Ideas Among the Accessories

## Start-Lite Illumination

THE system of lighting a car which is illustrated in Fig. 3 is made so as to relieve the driver of all trouble in lighting the lamps. It is made by the Start-Lite Company, of 1502 Michigan avenue, Chicago, Ill. In this system gas

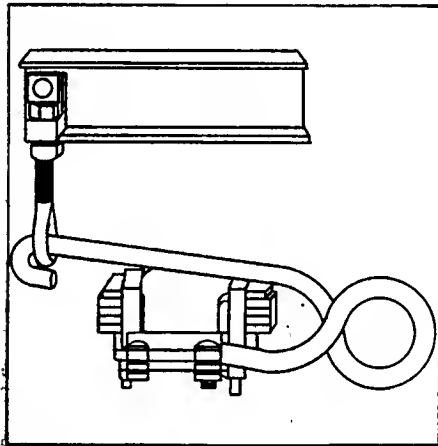

Fig. 1—View of the Ideal Shock Absorber

is led through suitable connections and piping to all the lamps and lights on the automobile. The control mechanism for the entire system is installed on the dash of the car, and gas may be admitted to one lamp or all of them at a time, according to the desire of the operator. On the same controller is also installed a switch for each headlight, sidelight and taillamp, and

by switching on the current, a spark is produced in the gap of the sparker located above the burner of the respective lamp. The figure brings out clearly all the details of the wiring and piping systems serving the purpose of illumination on the automobile, and the installation of the system is simple enough to be undertaken by any mechanic. All the acetylene is taken from one tank, and all the current required comes from a battery, both being preferably installed upon the running boards of the car.

## Ideal Shock Absorber

The Ideal type of shock absorber, Figs. 1 and 2, consists of two elements, as may be seen in Fig. 1. One is a steel loop attached to the chassis frame by means of a bolt and nuts, while the other is a one-piece oil-tempered-steel spring, which is coiled at its middle portion and bent to form a hook at one end. This hook engages the loop aforementioned, while the other end, which is only half as far from the spring coil, is securely fixed to the axle of the car.

In its normal state the shock absorber is in the position shown by the full lines in Fig. 2. Here the two arms of the absorber spring are in an almost parallel position. If an automobile thus equipped hits a thank-ye-mar'm, the Ideal spring prevents the car springs from coming together and hitting the axle, by assuming

the position B. At the same time, a great deal of the energy transmitted to the axle by the shock is taken up by changing the position of the absorber spring, which thus assists the ordinary springs in their business. The opposite effect of the absorber spring is used in hitting a bump. Here the inertia of the spring causes it to take

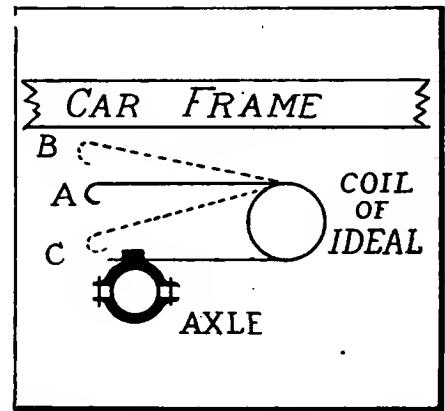

Fig. 2—Principle and operation of Ideal

on the position C, thereby absorbing most of the shock which otherwise would be transmitted to the body and the passengers occupying the same, causing discomfort and deterioration.

While the use of shock absorbers on the rear axle of a car is becoming quite common practice, the application of Ideal springs to the front of the automobile softens the effects of the road inequalities otherwise affecting the power plant and front portion of the chassis, thus relieving these portions of severe strains and adding to the life of the machine as a whole. The Ideal shock absorber springs, which are sold at a very moderate price, are guaranteed against breakage for 5 years. They are handled by the American Sales Company, of 1882 Mount Elliott avenue, Detroit, Mich.

## Wright Spark Plug

The N. Y. Mica & Manufacturing Company, whose factory is located at Auburn, N. Y., are marketing a new type of Wright spark plug. The claims of principal importance of this new plug made by the manufacturer thereof are the strength and heat-resisting qualities of the porcelain insulation. Where the porcelain core comes in contact with the hex and the asbestos bushings the shoulders of the porcelain core are cut with a round sweep so as to eliminate the danger of cracking at the narrowest point in the porcelain.

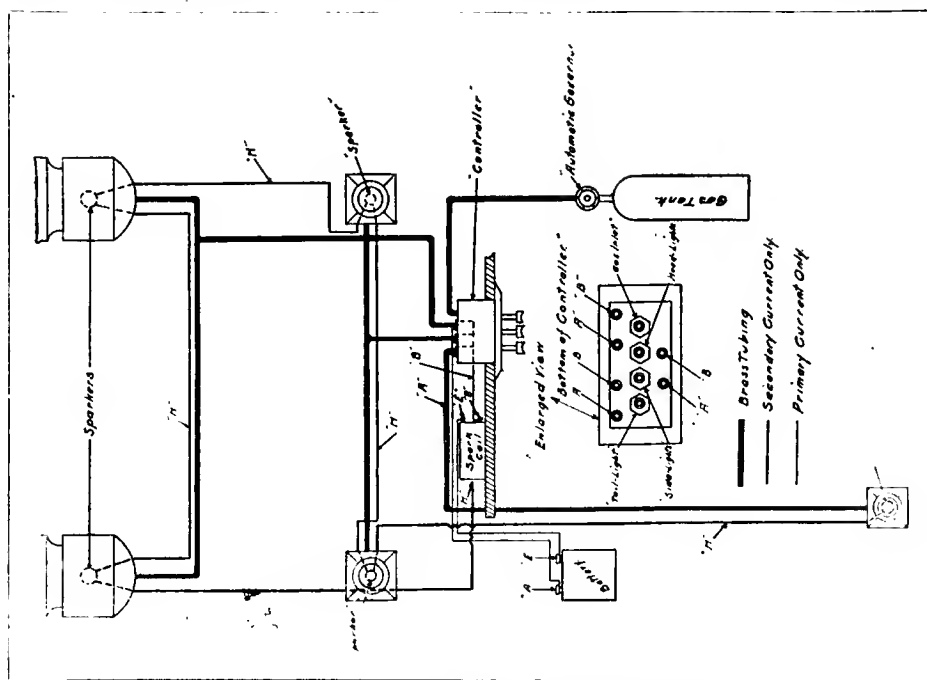

Fig. 3—Wiring and piping diagram of Start-Lite system

# THE AUTOMOBILE

## Many New Features at Olympia Show



GENERAL VIEW OF THE INTERIOR OF THE TENTH ANNUAL AUTOMOBILE SHOW AT OLYMPIA

LONDON, Nov. 3.—John Bull opened his tenth annual automobile exhibition to-day at Olympia, a hall almost as cramped as the Grand Central Palace, without that building's advantage of central location. Britain's free trade policy has made the London exhibition the only international one in the world, for in addition to the home products it brings together the best from France, Germany and Italy, and a certain amount of American representation. It would perhaps be more correct to say that it attempts to bring together the automobile product of the whole world, for, the hall being altogether too small for requirements, numbers of makes are crowded out, and among those having applied in vain for admission are at least half a dozen American concerns most recently introduced to the European market.

As was to be expected, the question of obtaining a substitute for poppet-valves is being given a large amount of attention by

the engineers of all European countries, and out of the mass of schemes submitted by enthusiastic inventors to level-headed business managers three have survived. In the background are many more almost ripe for public presentation, and many of them will doubtless come forth at no distant date.

The three new systems are the Henriot rotary valve adopted by Darracq for one model of car only; the single sleeve valve taken up by the Argyll Company, and a rotary valve by the Itala concern. It is worth noting that in all three cases the rotary or sleeve-valve motors are being produced concurrently with poppet-valve types.

The Henriot is the most familiar of the three, for it has been exhibited by the inventor at earlier shows in Paris and demonstrated by him on cars during the past two years.

The Argyll motor has a single sleeve with a combined rotary and reciprocating motion within the cylinder. In other words

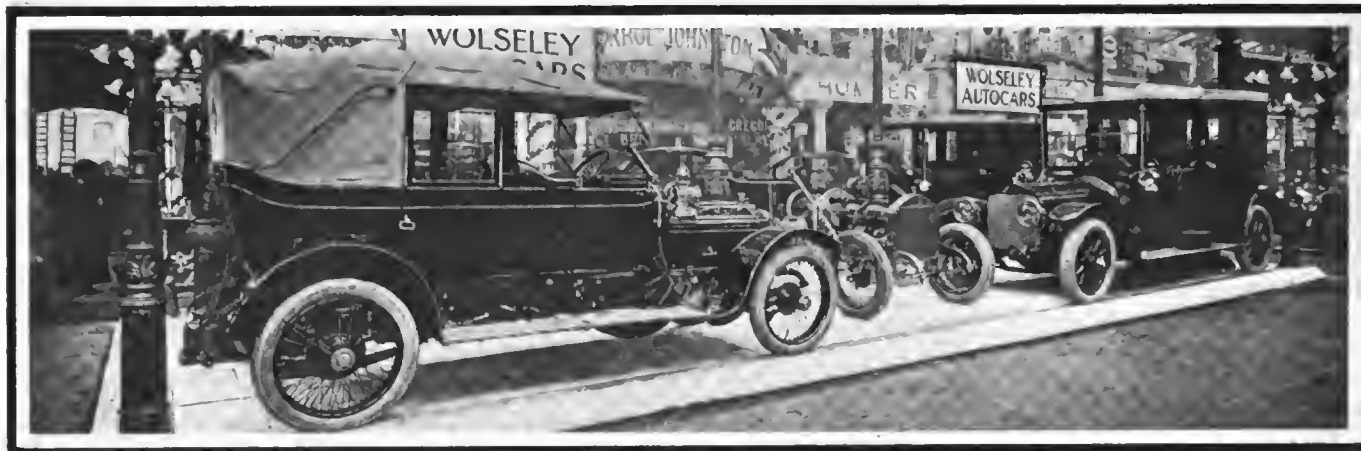

The Wolseley stand at Olympia was representative of one of Britain's foremost factories

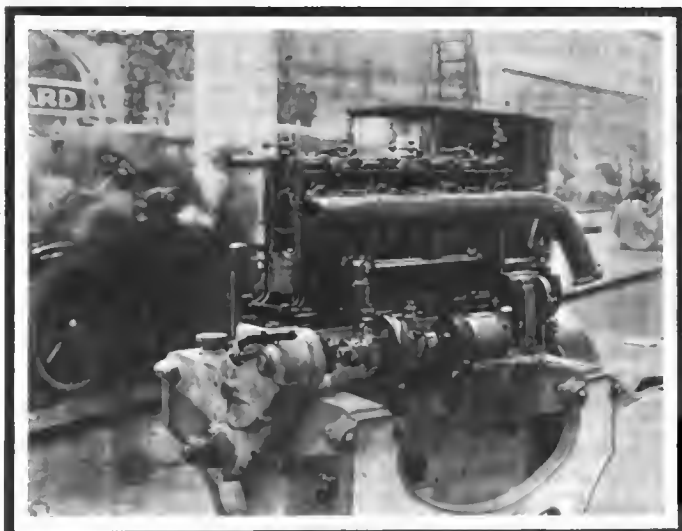

New Silent Knight Minerva motor with magneto and water pump at side

it describes an ellipse during two complete revolutions of the crankshaft. The idea is one which has been seized upon by a number of inventors, for Da Costa, in Paris, produced a motor of this type, but abandoned it for a single rotary sleeve after experiencing considerable difficulty in finding a good driving system. Also, it is a strange coincidence that while the Argyll people were working on their sleeve-valve motor, the Piccard-Pictet engineers in Geneva were at work on an almost identical design. When the Swiss applied for patents in England they found that they had been forestalled by Argyll, and when the Scotchmen made application on the Continent they discovered someone already in possession. The outcome was a compromise, each firm having rights in its own country.

The single sleeve of the Argyll is about 1-8-inch thick, naturally ground inside and out, and carries at its base a lug to which is attached a vertically pivoted pin and a small face block. At right angles to the pin is a spindle having a bearing in a gear wheel, this latter meshing with a pinion on a lay shaft driven at motor speed by means of a silent chain in the fore portion of the engine base. The inventor has made use of five ports in the sleeve and six in the cylinder, one of the port sleeves doing service for both an inlet and an exhaust port in the cylinder. The valve ports are not cut rectangular, but to a duplicated curve in order to assure the quickest possible opening and closing. As in the Knight system, a separate head is employed; it carries a broad junk ring and a narrow piston ring, all of them being pinned to prevent turning.

Two important features are that at the moment of explosion all the ports in the sleeve are protected behind the extended head; further, after the passage of the exhaust gases the ports in the sleeves immediately pass to a waterjacketed portion of

the cylinder walls. Lubrication has been thoroughly provided for by means of a force-feed system to all main bearings, troughs for the connecting-rod ends, and separate leads to each of the sleeve-operating mechanisms. The motor, which has a 25-horsepower rating, has its cylinders cast in two pairs.

The new Itala, which is a four-cylinder of 105 by 150 mm. bore and stroke, makes use of one pair of rotary valves for the four cylinders, each valve of course performing the necessary functions for the two cylinders cast together. On each casting is an outstanding cylindrical casing having an internal diameter of 4 inches, and within each of these cylindrical casings are two ports  $\frac{3}{4}$ -inch wide by 3 inches in length through which the charge passes to the respective cylinders and the spent gases are liberated. The distributor valve is provided with three sets of rings, one at the base, one set on the upper portion of the body of the distributor and the third set on the end of the upper extension. The distributor valves revolve at one-quarter motor speed, the ports in the distributor being duplicated so that alternate inlet charges and alternate exhaust charges come in contact with a given port in the rotary valve. The ports in the distributor are so arranged as to lead the exhaust gases from the cylinder port up the rotary valve and out through the head into the exhaust manifold. The fresh gases pass in from the base of the valve directly into the combustion chamber. The exhaust ports in the rotary valve are cut about 30 per cent. greater area than the intake ports. As difficulties might be expected with overheating in a valve fulfilling the two functions, the designer has very cleverly cored the valve itself so as to provide as efficient a circulation of water through it as around the cylinder walls. Driving of the rotary valves is obtained by means of two vertical spindles—one for each valve and for each pair of cylinders—with spiral gearing from a horizontal shaft in the position of the usual camshaft. It is from this shaft that drive is transmitted to a central transverse shaft having the water pump on the right and the magneto on the left. Provision has been made for a possible seizure of the rotary by the use of a safety coupling with undercut tongues which can be sheared off in case of any unusual resistance. On the base of the driving spindle is an Oldham coupling having a brass ring with two full and two under-cut dogs, these latter capable of being sheared if seizure takes place. A fresh ring can be fitted into position in place of the damaged one.

#### The Knight Motor Is Prominent

The Knight motor has made further progress, for while being continued by the Daimler Company for all models, Panhard now produces a smaller type of 80 by 130 mm. bore and stroke, the B. S. A. Company has taken it up for a cheap car, the Rover Company employs it, and the Deasy concern is making use of it for one model; and Giradot, of C. G. V. fame, is to use it in 2,000 cars for the coming season.

Important among the new tendencies is the unit type of construction for motor, clutch and gearbox, generally combined



with three-point suspensions. The idea is old, but it is one which has never caught on in Europe until the present season. Now the lead has been taken by the Panhard, which has built the new Knight chassis on these lines, the motor being attached to the frame members by two hangers, and the rear suspension being to a transverse frame member. Another important convert is the De Dion, which has adopted unit construction and three-point suspension for two new light cars having one and two cylinders respectively. Several less important firms have taken up this type of construction.

### Monobloc Cylinders Are the Rule

The tendency is more and more towards monobloc casting for large motors having four or six cylinders. There appeared to be only one example of a motor with separately cast cylinders with a five-bearing crankshaft, this being on a little known English car. In the matter of monobloc casting the Continental manufacturers have certainly secured a lead on their English rivals; indeed clean-cut appearance and general accessibility is far more pronounced on the generality of the foreign than on the average home product. Combined with this tendency towards monobloc castings is the use of thermo-syphon water circulation for models of the largest size. It has been common to use thermo-syphon for the small cars and pump circulation for motors having 4 inches bore or more. Now, however, it is being extended to cars of unlimited power, and in addition to the Renault, which has always led in this direction, thermo-syphon cooling is being adopted by the Darracq, Charron, and Delage for motors developing as high as 60 horse-power.

The coming system of lubrication in Europe is of the force-feed type, the base of the crank chamber forming an oil tank from which the lubricant is drawn by a pump and delivered to the main bearings and through the bored crankshaft to the connecting-rod ends. At least a score of firms could be mentioned which have taken up this system with various detail modifications. Apparently difficulty has been experienced in certain cases in forcing oil right through a two-bearing crankshaft for a four-cylinder motor, or from the center bearings of a six-cylinder motor to the more distant connecting-rod ends. This has led, in the case of the Chenard-Walker motors, to the bolting of light aluminum casings having a semicircular oil lead onto the two inner webs of the crankshaft; thus the shaft is only bored through from the two main bearings to the two outer connecting-rods, the flow from these two points being through the bolted-on oil leads. Where a three-bearing crankshaft is employed the favorite method is similar to that employed on the new Panhard-Knight, where the oil is delivered direct to the three bearings and distributed through the shaft from the end bearings to the two outer connecting-rod ends, and from the center bearing to the two central connecting-rod ends. The only other system which is receiving any considerable amount of favor is force-feed to the main bearings and troughs with dippers for the connecting-rod ends. It avoids the necessity

of boring the mainshaft, but it is a system which will doubtless have to give way before force-feed throughout. A few makers have retained splash on the plea of simplicity, and on the Charron the flow from the tank on the dashboard is connected up to the accelerator pedal, so that the amount of drip is in proportion to the extent that the accelerator pedal is depressed. The arrangement is neatly carried out, for the oil tank is built into the same casing as the gasoline tank on the dash, and the interconnecting mechanism is within a dummy portion of the tank on the extreme right-hand side.

Chain drive for the camshaft has not yet ousted pinions, but it appears to be in a fair way of doing so, for one or two chains are being used on nearly half the motors exhibited. It has now been found, however, that provision must be made for taking up slack, and this is being done either by means of an idler pinion mounted on an eccentric or by means of an eccentric mounting for the magneto shaft, where the motor has one chain only for cam and magneto shafts.

There is little that is new in ignition devices, the high-tension magneto reigning supreme. Even the preference shown by the English for a secondary ignition as a standby has now disappeared, apparently being satisfied by the dual ignition on one set of plugs. A beginning is shown towards the adoption of dual high-tension ignition firing two plugs simultaneously in one cylinder. This has been adopted for some time on racing cars, but is only just beginning to make its appearance on touring models.

The three-speed gearboxes which were formerly fitted on most of the small and medium powered cars are having to give place to four speeds with gate change. There are very few cars, now, of whatever power, which are not provided with four forward speeds, while those French manufacturers who clung to the straight-through type of sector have been obliged to fit a selective type to meet the requirements of the English market.

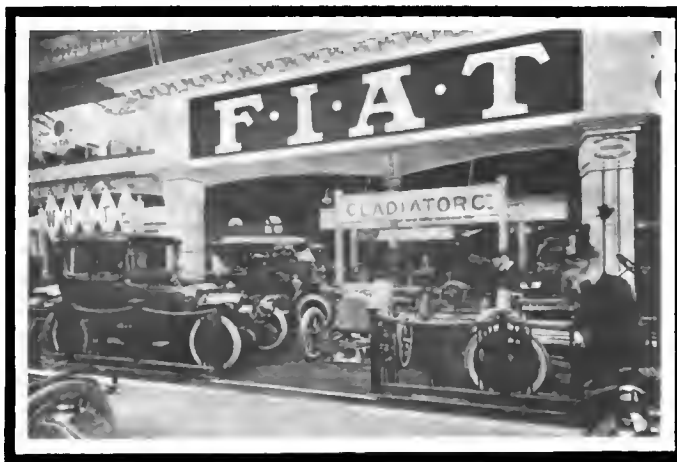

Where the Fiat held forth at Olympia



32-horsepower Jackson Demon torpedo



Elegant exhibit of the Star Engineering Company

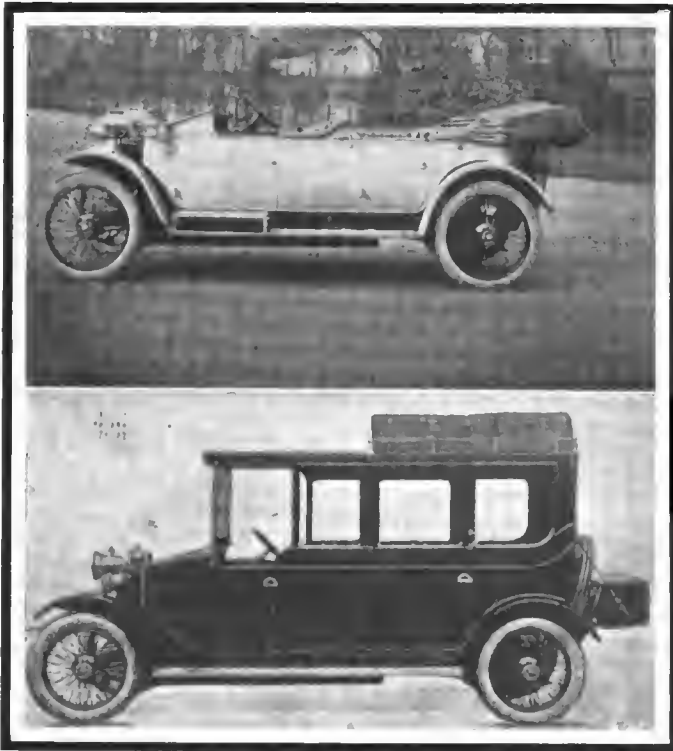

Two types of body construction shown at Olympia by the Lanchester Company

Notably among those having made this change is the Delaunay-Belleville Company. Chain driven gearboxes have been promised and indeed are used in France by Aries, and in London by the General Omnibus Company, but they have made their appearance on only two makes of touring cars, both of British construction. Final drive by worm gearing remains an English idea, at least half a dozen firms having taken it up, whereas in France Darracq is its only producer. Even in this case the change has been made more with a view to meeting English than French requirements.

A novelty in brake construction is shown by the La Buire Company in the form of a foot-brake on an extension of the propeller shaft. The shaft passes right through the differential housing and it is on the projecting extremity that the additional brake is mounted. The Argyll Company, on its new sleeve-valve model, brakes on all four wheels diagonally, a rear wheel on one side and a front wheel on the opposite side being operated together.

## A Review of the Design

A GREAT number of American firms are not to be seen within the big hall or its annex, owing to the fact that their membership is not yet one year old. The United International Motors, Ltd., which has started on a big scale to sell Maxwell and Stoddard cars in the United Kingdom, has found itself outside the pale. Amongst others the Cameron air-cooled car, the Mitchell, the Hudson, the Krit, the Flanders, the E. M. F. have also failed to get a place in the exhibition. The chief American cars on show are the White, the Cadillac, the Overland, the Buick, the Hupmobile and the Ford, to which perhaps one or two may be added after a closer inspection of all the stands. Of course an attempt has been made to make capital out of this exclusion of so many American agents, the suggestion being made that the society has desired to throw obstacles in the way of those who are putting on the English market cars of a price with which English manufacturers find it difficult to compete. That there is no foundation for this rumor is evident from the fact that English people have also been excluded, together with even such an important firm as the Zenith Carbureter Company, which is supplying carbureters to a very great number of leading manufacturers.

This year at Olympia there is scarcely a single car of merit that has not abandoned spur gear for driving the accessories of the engine.

The magneto and water pump, if these are not driven directly off the camshaft, are operated by silent chains or worm-gear. In fact, this is the most noticeable tendency in the whole of the exhibition. One firm has gone even to the length of introducing a gearbox in which the changes of speed are obtained by silent chains. This firm is the Maudslay, which has always been remarkable for the pains it has taken to give great accessibility as well as science. It is a firm with fine traditions, having been well known in the forties and fifties of the last century for its steam engines, examples of which may be found in mechanical museums all over the world.

There seems little unanimity about the worm-driven back axle which was brought to the front last year. It has been used by Lanchester and by Dennis for a number of years, but they were alone until the Show of 1910, when the Daimler Company with several others decided to adopt it. This year it has found some new adherents, but one or two of the firms who spoke so highly of it last year are now quietly dropping it. Its great merits were said to be silence and ease of fitting. The bevel gear is certainly inclined to produce chattering besides

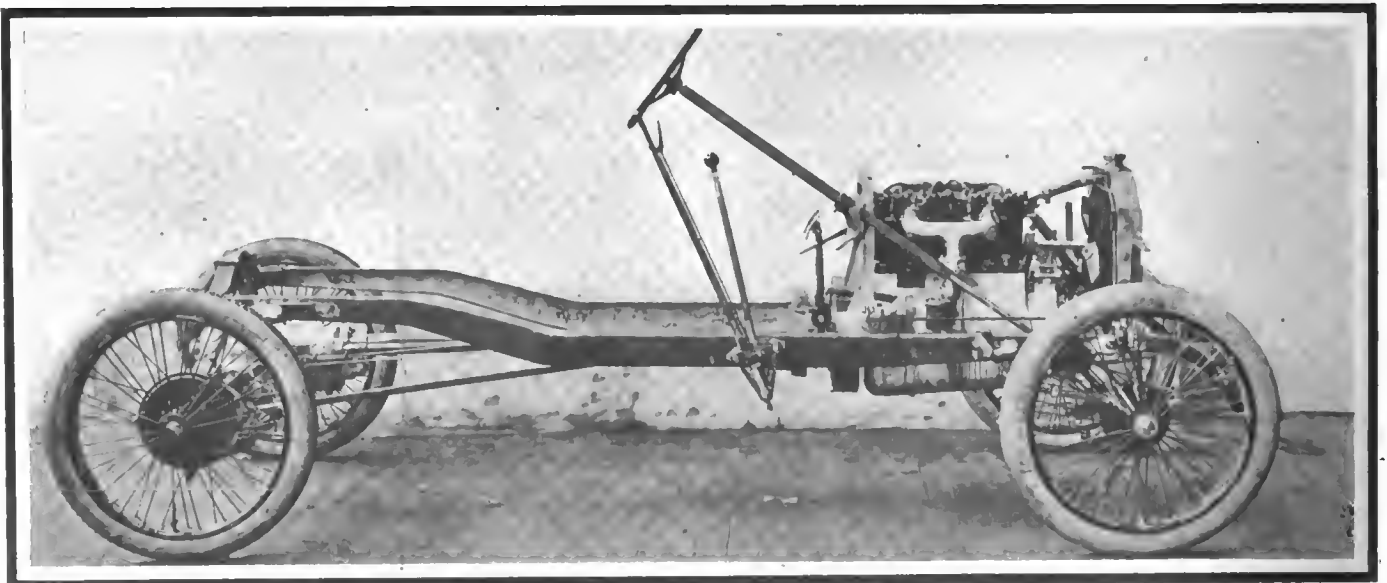

Chassis of the low-priced car with Knight motor put out by the B. S. A. Company

## Tendencies at Olympia

humming, whereas the worm drive is indeed really silent. It is now said by one or two manufacturers that the bevel drive is far superior in hilly districts, and they advise customers not to have worm drive if the car is likely to be called upon to do very much hill climbing. In this year's exhibition there are firms using both worm drive and bevel drive.

Front brakes appear to be losing favor, after having been introduced with a rush about two years ago. The fault seems to lie not with the principle, but with the design, because the firms that have the best designs are still fitting the front brakes. The Argyll has introduced them on its new 25-horsepower sleeve-valve model, and in this case the front and rear brakes are diagonally cross-connected for the purpose of preventing the tendency towards side slipping which is sometimes shown by cars with front wheel brakes. In the matter of brakes the best innovation stands to the credit of the La Buire car, on which the drum of the foot-brake is found at the rear of the differential casing. It is mounted on an extension of the bevel shaft, and of course in this position no brake-stresses are transmitted through the universal joints. This seems a very logical position for the front brake to occupy.

Six-cylinder motors have settled down on a rational basis. They are supplied by most firms if a car of fairly high power is demanded. The only firm which was manufacturing a really small-powered six-cylinder car has dropped the model for this year. Delaunay-Belleville has a six-cylinder car of a nominal 10 horsepower, but this year its smallest six-cylinder model is nominally 19 horsepower. The fashion set by the Rolls-Royce to cast the cylinders in two sets of three is now being copied by the best makers of six-cylinder cars. Exactly what the benefit is does not appear to be very clear. Quite a new idea is the vibration damper to be found on the Daimler and Deasy cars. At certain critical speeds the engine tends to cause noticeable vibration, the cause of which has been discovered to be the length of the crankshaft. The addition of the damper, which is something in the nature of a slipping clutch arrangement, has been found to keep the engine running smoothly over its whole range of speed. These dampers are fitted at the forward end of the crankshaft.

It may be stated that the long-stroke engine is finding favor. The longest strokes are found in the cars produced by firms which have had racing experience. This feature now has additional importance in England owing to the sliding scale of taxation being based upon the horsepower rating, which is

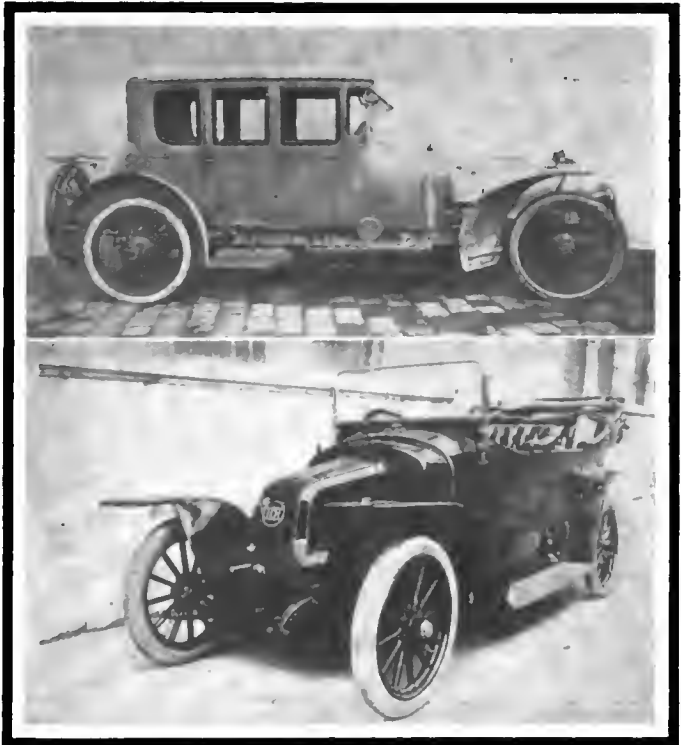

Delaunay-Belleville with inside-steering body  
Darracq touring car with rotary valve motor

reckoned entirely by cylinder bore. The classes that have been introduced for taxation are now plainly governing the choice of cylinder bores. Thus one finds 11.9-horsepower cars in fair numbers, these just escaping the 12-horsepower tax. Similarly, a big number of 15.9-horsepower models have been introduced to escape the 16-horsepower tax. This is a point which American manufacturers should bear in mind. The assembling of engine clutch and gearbox in one unit has found a few more adherents, and the enclosed valve gear has become much more popular.

Only the Cadillac car has been added to the list of models which fit a self-starter. The Cadillac system is at present unique, being operated electrically, whereas all other models of self-starters operate by compressed air. Some firms like the Belleville, Seat and Enfield now make provision for the fitting of compressed-air self-starters, but are not supplying the parts as standard equipment. In addition to a service of compressed air for tire inflation, as well as for engine starting,



Chassis of the 15-horsepower Austin, showing separate cylinders and cased-in change-speed bracket

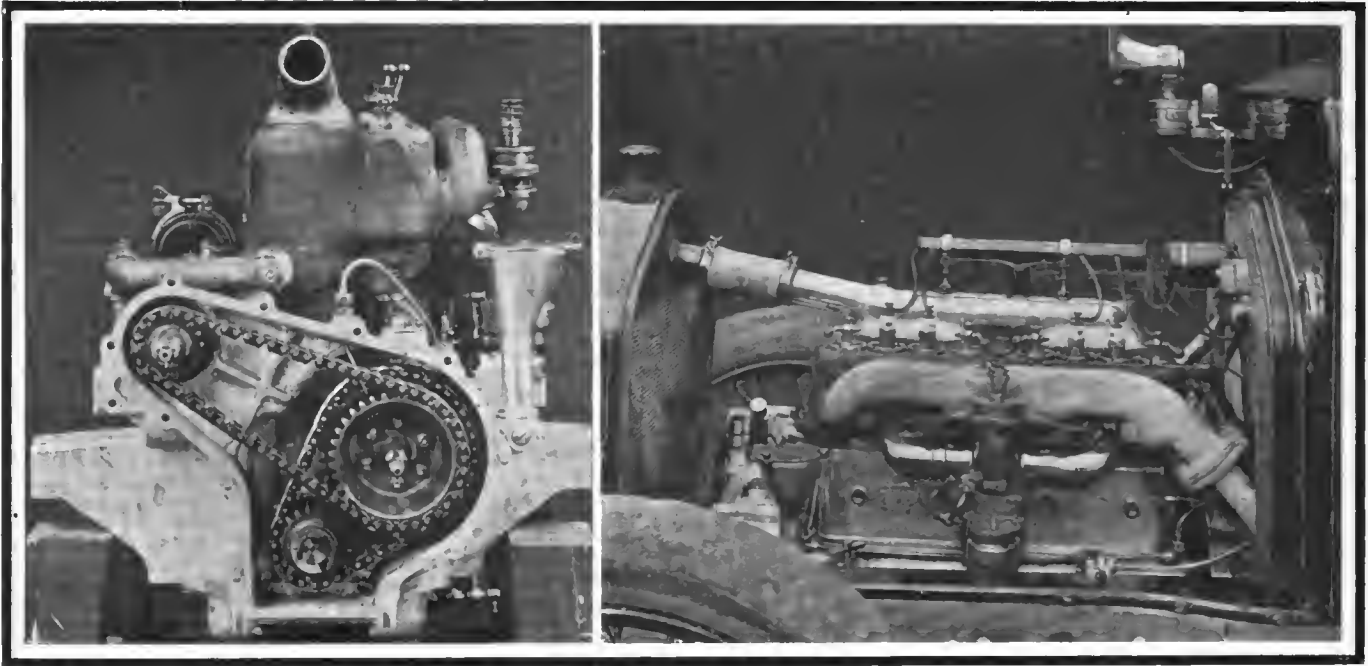

Two views of the Wolseley 16-20-horsepower engine, one showing the gear cover removed

one or two manufacturers are arranging for the use of pneumatic jacks.

On some of the cheaper cars wire wheels of the fixed pattern have been adopted. A very noticeable movement towards four-speed gearboxes on cars of small and moderate power is seen at this show. And if one adds that still a few more manufacturers have gone over to the plate clutch one completes a review of the general tendencies that are to be noted in the design of cars at the Olympia exhibition.

#### Some Features of the Small Panhard

For the 1912 season the Panhard Levassor Company will produce two models with the Knight sleeve-valve motor, the four-cylinder of 100 by 140 and a smaller model having four cylinders of 80 by 130 millimeters (3.1 by 5.1 ins.) This is the most popular size of motor in Europe at the present time, and with the introduction of this model almost half the Panhard output will consist of Knight motors. A poppet-valve motor of the same bore is already manufactured, but the new Knight is not intended to replace this, and is indeed an entirely new chassis, departing in many important respects from previous

Panhard design. The motor has its four cylinders cast in pairs, and is on the unit principle, the motor, clutch and gearbox forming a single bloc with three-point suspension. The crank-shaft is carried on three plain bearings, while the chain, instead of being in a separate housing at the front of the motor, is now removed to the rear.

As on the larger Knight motor, a transverse shaft at the front of the motor drives the magneto on the left and the water pump on the right. An important change has been made in the lubrication of the motor; instead of a circulating system, the base of the crank chamber forms an oil sump from which the lubricant is drawn by a pump working off the eccentric shaft and delivered to the three main bearings, then through the bored shaft to the connecting-rod ends. The shaft is not bored throughout, but the oil delivered to the central bearing is carried through to two connecting-rod ends; the lead from the end bearings is through to the outer connecting-rod ends.

The clutch and gearset are within a separate housing independent of the crank chamber, yet bolted to it in order to form one bloc, the whole unit being attached to the frame by two hangers about level with the rear of the second cylinder and

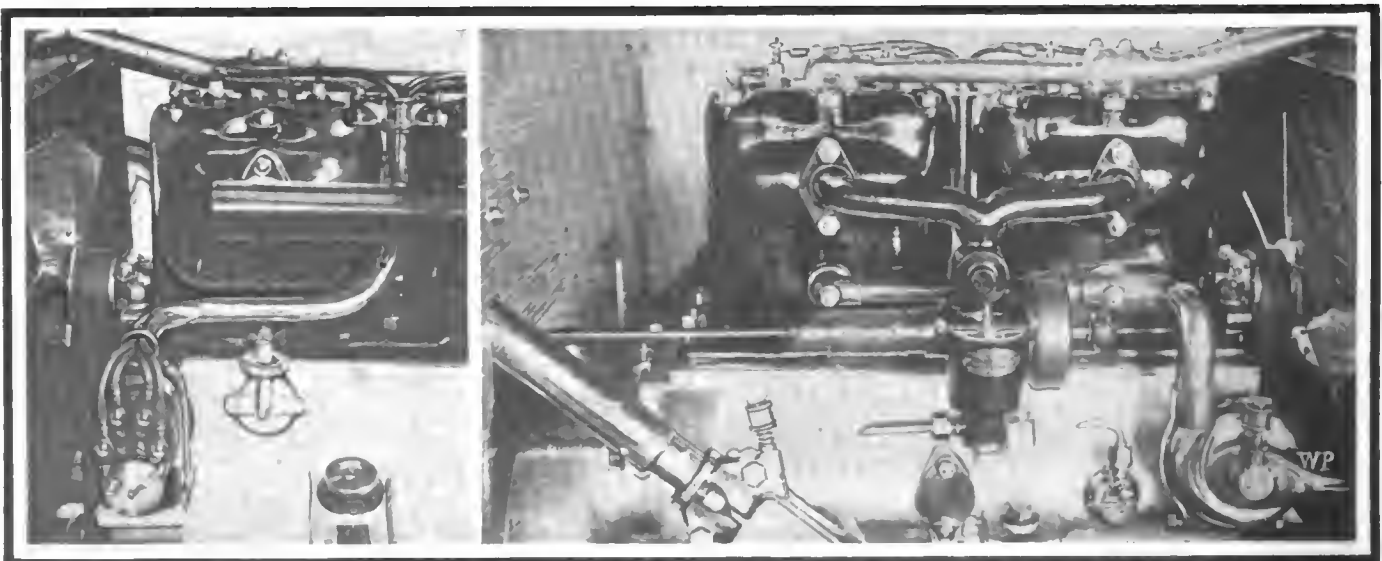

Showing some of the details of the small Panhard engine with Knight sleeve valves



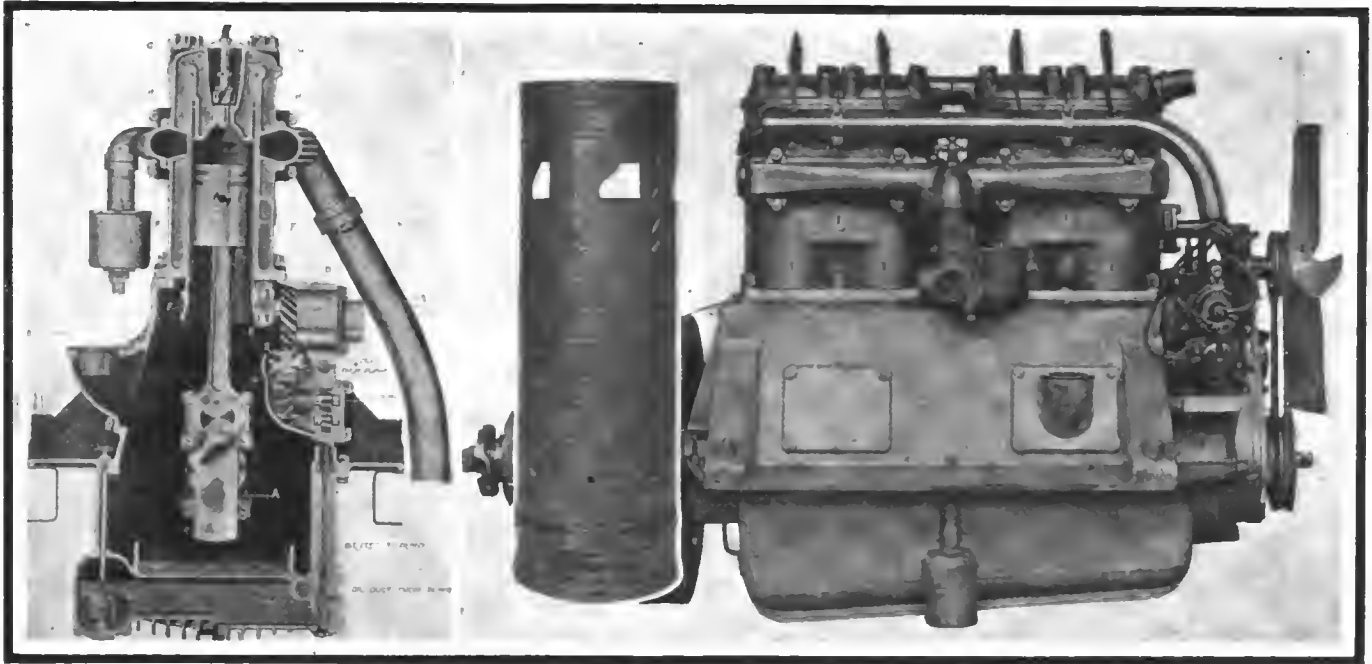

Vertical section and side view of the Argyll single-sleeve motor

at the rear of the gearbox to a double channel-section transverse member. Hitherto Panhard clutches have been either cone or multiple discs; on this model a plate clutch is used, the surfaces being fibre and steel. The gearbox gives four speeds with two sliding sets of gears operated by a straight-through sector and a cam mechanism within the gearbox, as on some of the firm's trucks. Clutch and gear housing come under the footboards, and on the top of the housing are two large inspection plates, each one held down by a single screw. Final drive is by propeller shaft with bevel gearing, the shaft being carried in a torque tube, and the tube stayed triangularly from a point one-third from the rear to a point under the spring seating. The rear axle is also a new design, the housing being formed of two tapered tubes bolted to the halves of the vertically divided differential housing. The rear axle is not trussed in any way. The abolition of the independent gearbox has carried with it the disappearance of the transmission brake. All braking is now done on the rear wheels, there being two expanding shoes side by side within each drum, one pair being operated by pedal and the other by the side lever with connection made by steel ribbons guided through fiber rollers.

### The Argyll Single-Sleeve Valve Engine

The main difference between the Argyll and the Knight motors is that the former uses one sleeve and the latter two.

The crankshaft, connecting rod and piston are of the usual type; the special features of the engine being the single-sleeve valve with its specially shaped ports, the corresponding ports in the cylinder, and the mechanism for operating this valve so as to control the opening and closing of the admission and exhaust ports. As usual in four-stroke engines the valve is operated at half the engine speed.

In the cylinder there are six ports, three on each side, those on one side being exhaust ports and those on the other admission ports. In the sleeve there are five ports, two being admission and two exhaust, the odd port acting alternately as an admission and exhaust port. The cylinder is closed at the top end by means of the head, which may be described as a fixed piston, this piston being the same diameter as the motor piston and projecting into the cylinder so that between the cylinder wall and the head an annular space is formed in which the sleeve works.

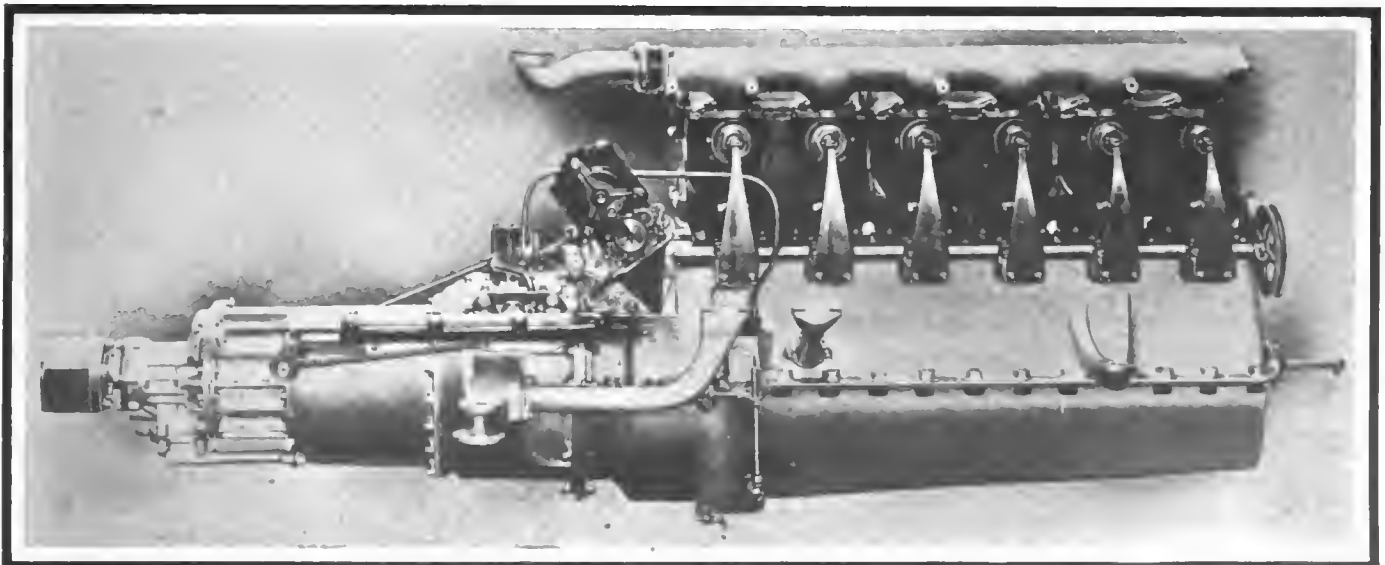

38-horsepower six-cylinder Lanchester power unit comprising engine, gearbox and brake



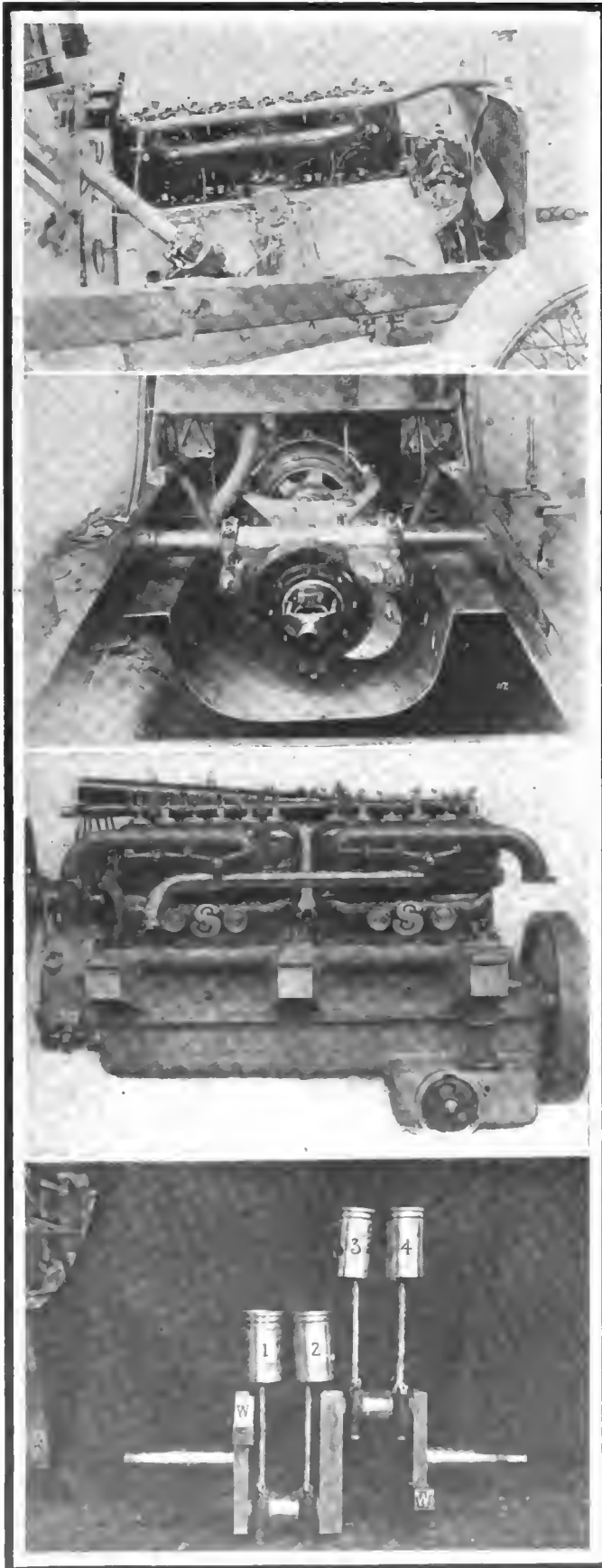

Carburetor side of 30-horsepower six-cylinder Daimler motor

Looking at the chassis of the 15-horsepower Crossley from the rear

Twenty-five horsepower Sheffield-Simplex, looking from the valve side

Two-throw crankshaft used on Sizaire-Naudin long-stroke motor

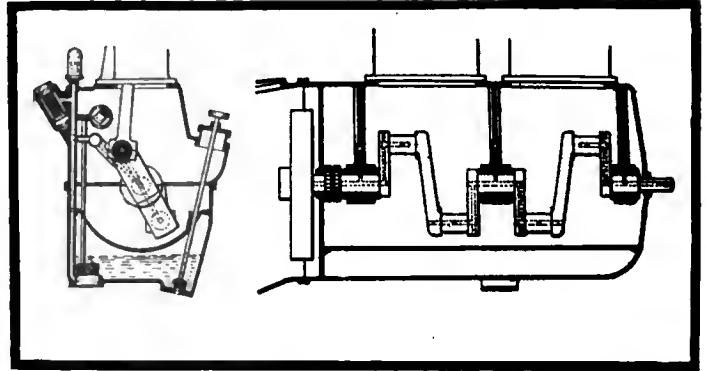

Lubricating system on Panhard 15-horsepower with Knight motor

The peculiar twisting motion of the sleeve of the Argyll motor may be likened to screwing a plug into a plain hole, where, by twisting the plug round, and at the same time pushing it in, it can be entered with comparative ease. On account of the twisting motion, which reduces the resistance, the sleeve never comes to rest, but is continually in motion in one direction; there is thus no dead center involving a sudden reversal of direction of travel. The twisting movement which allows of the sleeve ascending and descending by different paths, provides for a natural lubricating motion, spreading the oil over the entire surfaces with which the sleeves come in contact. It is impossible for a sleeve to seize, as even if the lubricating oil were cut off entirely the first thing to seize would be a piston or a bearing, and so efficient and reliable has the method of lubrication proved to be that this state of affairs is impossible except through gross carelessness or neglect.

When, after years of service have so worn the pistons and the insides of the sleeves that they require renewing, all that is necessary is a new sleeve valve and a standard piston, and as the sleeve and the parts therein are ground and cut accurately to standard, no fitting is required.

#### Long Stroke and Four Speeds Popular in England

The ratio of bore to stroke of British-built cars varies widely. Few of the makers appear to favor a cylinder diameter of less than 3 inches. Some of them, however, are putting out models around 12 horsepower with bores slightly under this figure. For motors of this size, the tendency is toward a stroke around 4 3/4 inches, although the 10-horsepower Austin, with a 2 1/2-inch bore, has a stroke of 3 1/2 inches. Most of the leading models have the long-stroke motor, as already stated. The ratio is seen to be considerably greater than 1, in most cases, with the exception of a single model—that of the New Engine Motor Company. The leading makers seem to lean toward a ratio of about 1.5 to 1, or even a larger figure, in their models having bores between 3 and 4 inches. Above this diameter, the ratio is lower, being around 1.25 to 1. The Sunbeam six, rated at from 25 to 30 horsepower, has the distinction of being the only model in the list with a stroke of 6 inches or over, its stroke being 6.31 inches with the small bore of 3.56 inches.

Few of the cars listed can be put in the high-power class; the Napier makers, however, exhibited a six-cylinder, 65-horsepower machine with a bore of 4 inches and a 5-inch stroke; ratio, 1.25.

Although the worm drive appears to be losing ground, a great number of the models still cling to it, among these being the Daimler, Maudslay and Rover. Others make it an optional feature, while still others specify bevel drive on all machines of their make. In the matter of numbers, at least, the latter appears to have the best of it, but it cannot be denied that there are points in favor of the former.

Together with the movement for longer stroke motors, is that for four-speed drive. Many of the older makers hold tenaciously to the three-speed type, but it would seem that they must

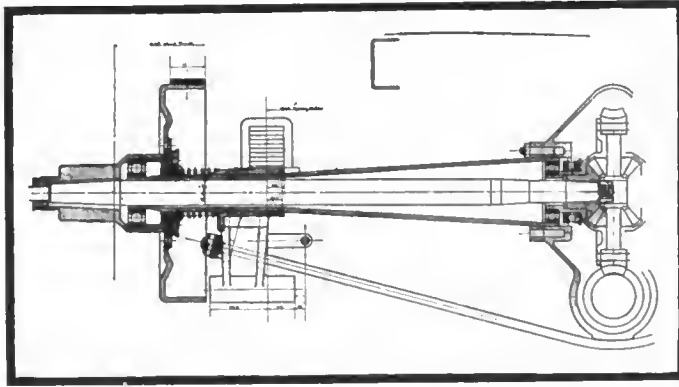

Rear axle arrangement used on the 20 and 30-horsepower Daimlers

all come to it in time. Conspicuous among those who still adhere to the three-speed drive are the Rolls Royce, Ltd., the Daimler Motor Co., Ltd., and S. F. Edge, Ltd. (manufacturer for or against either drive, but, from the number of makers using the four-speed type, it is evidently fast gaining ground.

The following table will show at a glance the principal mechanical data of the better-known English cars:

NAME	No. Cyl.	Bore Inches	Stroke Inches	Bore Stroke Ratio	Horse-power	Drive	Speeds
Adams	6	3.47	4.75	1.37	30	Bevel	4
Albion	4	3.13	5.00	1.61	15	Worm	3
Argyll's Limited	4	2.81	3.94	1.42	12	Worm	4
Argyll's Limited	4	3.56	5.50	1.55	20	Bevel	4
Argyll's Limited	4	4.00	5.13	1.28	25	Worm	4
Armstrong, Whitworth & Co.	4	3.16	5.31	1.68	15.9	Bev'lorWorm	4
Armstrong, Whitworth & Co.	4	3.75	4.72	1.25	22.5	Bevel	4
Armstrong, Whitworth & Co.	4	3.56	5.31	1.49	30	Spiral Bevel	4
Armstrong, Whitworth & Co.	4	2.50	3.50	1.40	10	Bevel	4
Austin	4	4.38	5.00	1.14	18-24	Bevel	4
Austin	6	4.38	5.00	1.14	50	Bevel	4
Austin	6	2.72	5.13	1.89	10-12	Worm	3
Belsize	4	3.69	4.75	1.29	18-22	Bev'lorWorm	4
Belsize	6	2.94	4.50	1.53	14	Worm	4
B. S. A.	4	4.03	4.38	1.09	10-12	Bevel	4
Clement	4	4.03	4.38	1.09	18-28	Bevel	4
Clement	4	4.22	5.13	1.22	25-35	Bevel	4
Clement	4	3.16	4.72	1.49	12	Bevel	4
Clement Talbot	4	3.16	4.72	1.49	20	Bevel	4
Clement Talbot	6	4.00	5.50	1.37	25	Bevel	4
Clement Talbot	4	4.00	5.50	1.37	20	Bevel	4
Crossley	4	3.16	5.13	1.63	15	Worm	3
Daimler	4	3.16	5.13	1.63	23	Worm	3
Daimler	6	4.88	5.13	1.05	38	Worm	3
Daimler	4	4.00	5.13	1.29	38	Worm	3
Daimler	6	2.97	4.34	1.46	12	Worm	4
Deasy	4	3.56	5.13	1.44	18-24	Worm	4
Deasy	6	3.56	5.13	1.44	24-30	Worm	4
Deasy	6	3.56	4.34	1.22	18	Worm	4
Dennis	4	3.94	5.13	1.30	10	Worm	4
Dennis	4	3.75	4.50	1.20	10	Bevel	4
Enfield	2	3.38	4.25	1.26	14-16	Bevel	4
Enfield	4	3.94	4.53	1.15	20	Bevel	4
Enfield	4	2.69	4.75	1.77	11	Bevel	3
Humber	4	3.56	4.75	1.33	20	Worm	4
Humber	4	4.13	5.13	1.24	28	Bevel	4
Humber	4	4.00	4.00	1.00	38	Worm	3
Lanchester	6	3.56	5.13	1.44	17	Worm	4
Maudslay	4	3.56	5.13	1.44	30	Worm	4
Maudslay	6	3.25	5.00	1.54	15	Bev'lorWorm	3
Napier	4	4.00	5.00	1.25	45	Bevel	3
Napier	6	4.00	5.00	1.25	65	Bevel	3
Napier	4	2.72	4.72	1.74	11.9	Bevel	4
New Arrol-Johnston	6	3.16	4.72	1.50	23.9	Worm	4
New Engine Motor Co.	4	5.00	4.50	0.90	40	Bevel	4
Rolls Royce	6	4.50	4.75	1.05	48.6	Bevel	3
Rover	1	3.81	4.48	1.18	6	Bevel	3
Rover	4	2.97	5.13	1.73	12	Poppet	3
Rover	2	3.00	5.13	1.71	12	Daiml'r	3
Rover	4	3.53	5.13	1.45	18	Worm	4
Sheffield Simplex	6	3.53	5.00	1.42	25	Bevel	3
Sheffield Simplex	6	4.50	4.50	1.00	45	Bevel	2
Singer	4	3.16	5.13	1.63	15	Bevel	1
Singer	4	3.56	5.13	1.44	20	Bevel	4
Star	4	2.69	4.72	1.75	10	Bevel	3
Star	4	3.56	4.72	1.33	15	Bevel	4
Star	6	3.16	4.72	1.49	20	Worm	4
S. S. & S.	4	3.44	4.72	1.37	15	Bev'lorWorm	3
Sunbeam	4	3.16	5.91	1.87	12-16	Bevel	4
Sunbeam	6	3.56	6.31	1.77	25-30	Bevel	4
Swift	1	4.13	5.00	1.21	7	Bevel	3
Swift	2	4.03	4.38	1.09	10-12	Bevel	3
Swift	4	3.34	4.72	1.11	15.18	Bevel	4
Thames Ironworks	4	3.16	5.31	1.68	15.9	Bevel	4
Thornycroft	1	4.50	5.00	1.11	30	Bevel	3
Vauxhall	6	3.56	4.72	1.32	30	Bevel	4
Wolseley	4	3.13	4.75	1.52	12-16	Worm	3
Wolseley	6	3.56	5.13	1.44	24.30	Bevel	4
Wolseley	6	4.50	5.75	1.28	50	Bevel	1

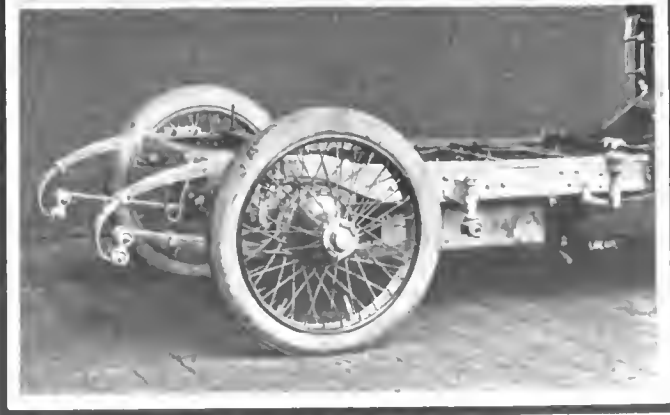
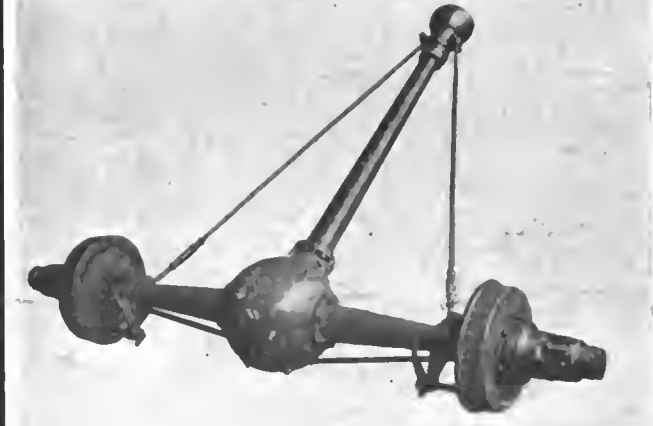
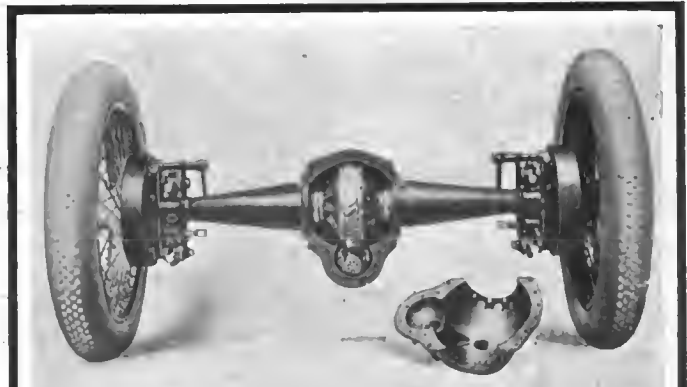

Rear axle of the Lanchester showing the differential cover removed  
 Rear axle of the Panhard—D, differential housing; T, axle casing  
 Showing general design of Crossley double-drive rear axle  
 Rear portion of Wolseley 16-20 chassis, showing spring arrangement



Front view of Sheffield-Simplex 1912 model motor

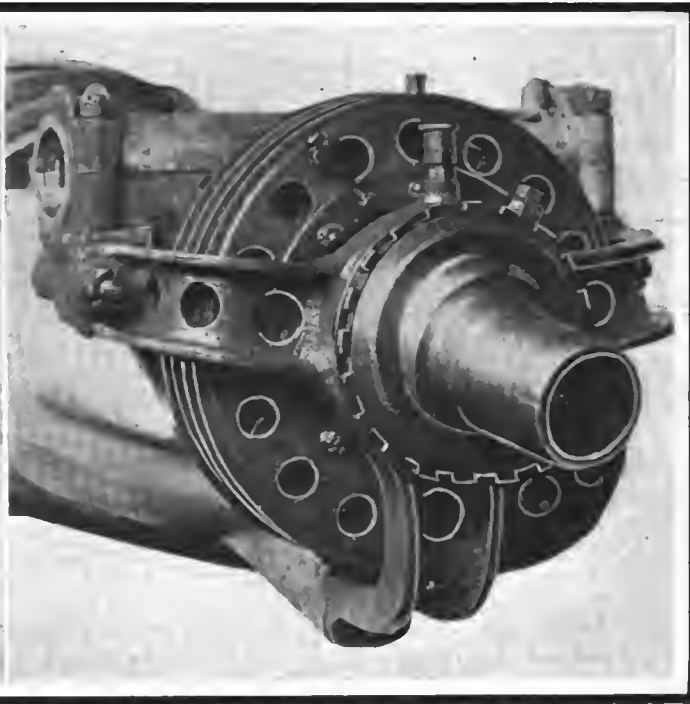

Showing details of the gearset of the 1912 Crossley



Rear axle and spring of B. S. A. car

**Average Prices of British Cars**

In 1911 there were seven one-cylinder cars manufactured and sold at prices varying from \$735 to \$1,305, the average price being \$1,010. For 1912 there are only six one-cylinder cars listed, and at a price of \$650 to \$1,175, the average price being \$835.

As regards two-cylinder cars, seven models were listed at a price of \$850 to \$1,365, the average working out at \$1,160 while for 1912 the number has increased to nine, ranging in price from \$750 to \$1,325, or an average of \$1,110 each.

With regard to four-cylinder cars, there is a considerable increase in the number of medium-powered four-cylinder cars to be placed on the market selling up to \$1,750: for example in 1911 there were nineteen four-cylinder models, varying in price from \$1,415 to \$1,750, the average price working out at \$1,555 each. This number for 1912 has increased to thirty-three models, varying in price from \$855 to \$1,700, the average price being \$1,285.

The cheapest four-cylinder car to be put on the market for

1912 is a 10-horsepower R. A. C. rating, sold complete at \$875, while the highest power car is one of 24.8 horsepower, sold complete at \$1,725.

The Belsize company, a firm which has hitherto been one of the leaders in the lower-price cars, has introduced a new model, 11.8 horsepower, which will be sold complete at \$1,050.

The Arrol-Johnston company is introducing a car of similar power at \$1,425 complete, while the Daimler company is introducing a car of 13.9 horsepower, sold as the B. S. A. for the price of \$1,625 complete, or chassis price \$1,250. Thus British manufacturers are producing lower-priced cars than has hitherto been the rule.

There appears to be no diminution in the number of British manufacturers; on the contrary the number of manufacturers has increased during the present year. Neither is there any diminution in the number of models produced, which shows an increase of about 10 per cent. The six-cylinder car maintains somewhat of a stationary position as regards numbers, and some twenty-eight models will be found listed in this class, the cheapest vehicle being the 29.4 horsepower Vulcan and the 36.2 horsepower Belsize, which are listed at \$1,975 for the chassis, while the most expensive are the 59.9-horsepower Napier at \$4,975 and the 48.6-horsepower Wolseley at \$5,000.

**British Trade Statistics**

During the year 1910, the value of the imports of cars, chassis and parts totalled \$25,673,830, of which re-exports were made to the value of \$2,610,860. The exports of British manufactured goods amounted to \$13,027,625, the actual number of cars manu-

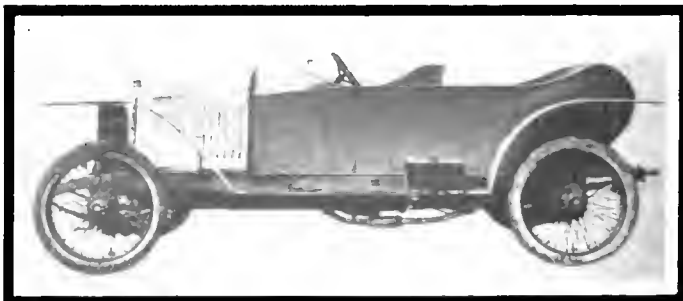

Vauxhall car with a new design of semi-racing body

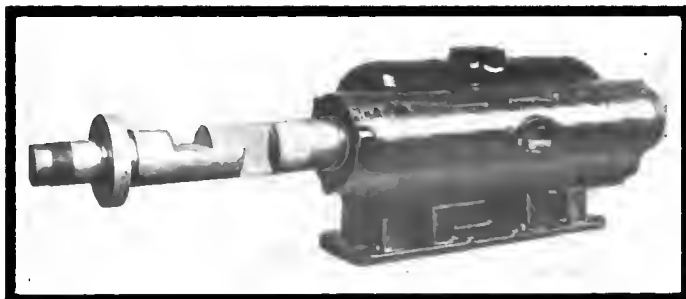

Cylinder casting of new Darracq with rotary valve partly withdrawn

factured by the British makers being between 18,000 and 19,000. The past season has been an extremely good one for the British manufacturer, and all the established firms have been able to keep their factories running at full pressures, and statistics which are made up to the end of September 30, 1911, go to show that the trade of 1911 will be considerably in excess of the trade of 1910, and that the prospects for 1912 are indeed favorable.

It is not quite easy to compute the actual number of cars built in Great Britain, but a fair estimate can be made by taking the increase in the registration, as given by the various county and borough county returns. In 1910 the total number of vehicles, excluding motor cycles, registered in Great Britain, was:

Motor cars .....	124,860
Commercial vehicles .....	7,406
<b>Total .....</b>	<b>132,266</b>

The corresponding figures for 1909 were 107,934, thus showing an increase in the number of cars registered of 24,332 in 1910; as a matter of fact, the actual number will be rather less; owing to the fact that lapsed registrations are not always accounted for.

In 1910, 2,995 cars and chassis were exported to British possessions, and 1,124 to foreign countries, of which 77 came from the United States.

The total imports for the 9 months to September 30, 1911, amount to \$22,825,965. The re-exports are valued at \$2,129,599, and the exports of British goods at \$10,600,000, which show a very large percentage of increase over the same period in 1910.

The imports comprised 10,125 vehicles and chassis, as compared with 8,352 in 1910, and there is no doubt that a considerable percentage of the increase represents American cars.

From the figures given above it will be seen that in 1910, 1,101 cars were imported from America, and there is evidence that that number will be more than doubled during the present year, as for the 7 months ending July the number of cars imported from the United States was 1,875, having a total value of \$1,635,995, the average price of the cars imported being \$885 each, whereas the average price of the total imports is \$1,305 and the average for 1910, \$1,430.

Although the threatened invasion of American cars has not yet to any great extent affected the English manufacturers, there is evidence that the manufacturers here are preparing to meet competition. It is quite evident that the imports of American cars to this country are of a type which have not been hitherto constructed by British makers, and little or no attempt has yet been made to produce a similar type in this country.

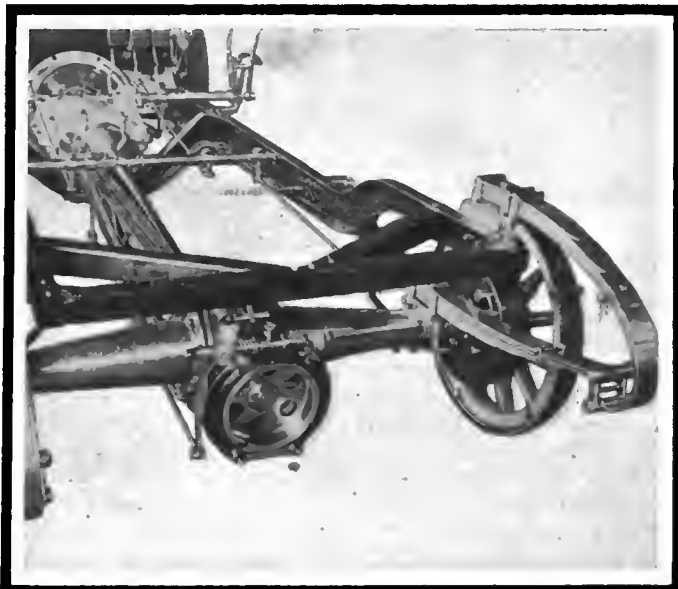

New differential brake used on La Buire cars

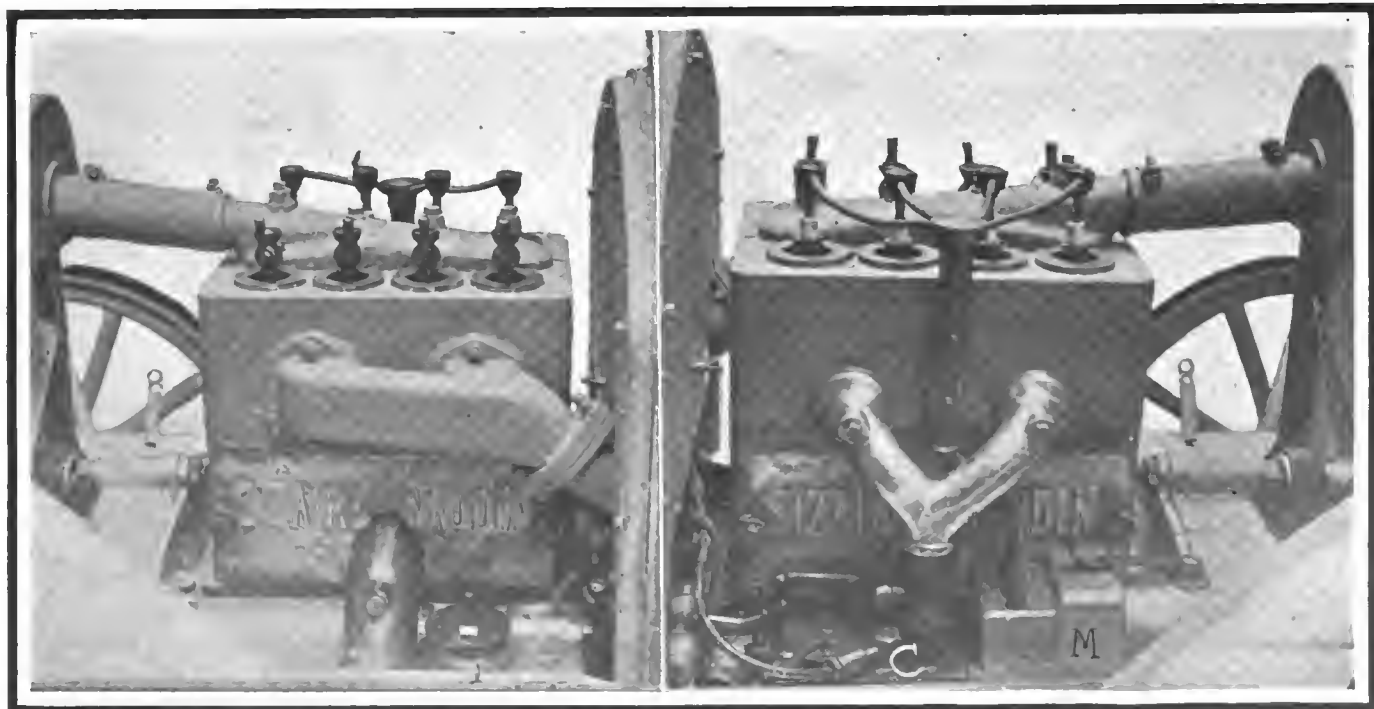

Exhaust and intake sides of the new Sizaire-Naudin motor—C, carbureter; M, magneto





Commissioner Watson piloting the T.C.A. touring party into Columbia, S. C.

# Capital Highway South's Trunk Line

THE most flattering thing you can say to Atlantans is that they live in the New York of the South and that Peachtree street is their Broadway. Indeed, it is harder to drive a car through Peachtree street than through Broadway because all the north and south travel is crowded onto this comparatively level thoroughfare and the traffic regulations are *nil*, each cart or carriage being a law unto itself. The street lights of lower Peachtree street are more picturesque and illuminating than those of Broadway, and, while it lacks the skyscrapers and electric signs of the "Great White Way," there is still the air of a bustling metropolis which the Northern visitor is scarcely prepared to see. There are about 12,000 automobiles registered in Georgia of which more than 3,000 are in Atlanta, being one to every tenth family. This, with other considerations, makes Atlanta the logical touring center of the South and consequently the most desirable point to be linked with New York by trunk-lines of motoring highway.

So much attention has been directed to the so-called National Highway that the unthinking may have lost sight of that other movement for the improvement of the Capital Highway, which has recently been covered *in toto* by the scouts of the Touring Club of America. This movement has been fostered

by the Capital Highway Association, of which Leonard Tufts is the president, and so much work has been done within the past three years that to-day more than two-thirds of the road between New York and Atlanta is in excellent touring condition and the balance is rapidly being completed. All of this improvement below Richmond consists of building sand-clay roads, which, when properly constructed, are equal to macadam. The peculiar



Lands in Harnet County, N. C., are barren and roads unimproved

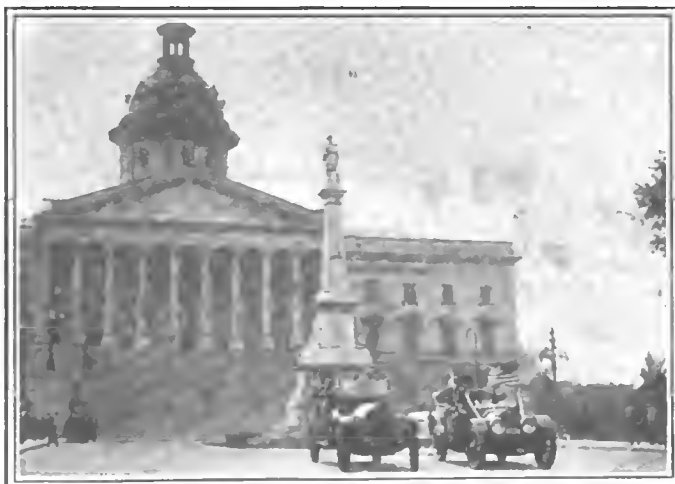

Lined up in front of the battle monument just before leaving Columbia

physical location of this route gives particular encouragement to the use of these materials for it approximately skirts the edge of the clay belt and in some cases one can literally dig sand from one side of the road and clay from the other. Then, too, it reaches the capital of every Southern State which it traverses, including the national capital at Washington, to say nothing of the numerous Winter resorts, such as Pinehurst, Camden and Aiken.

The only point on the Capital Highway of which the tourist should be warned is Culpeper, Va., where a carpet-bagging J. P. holds court, ably abetted by a horse doctor, both of whom in their more prosperous days hailed from a well-known Northern State. The first ten days' run of the recent scouting tour of the T. C. A. was made from Atlanta to Augusta, following closely



the Georgia Central Railway. The distance is 172 miles and was covered in ten hours' elapsed time through a driving rain. The only bad stretch is 20 miles between Madison and Greensboro, which is mostly slippery red clay. Beyond Greensboro the road is sandy, the last 20 miles being built of the famous cement gravel which is found in abundance in this section.

Crossing the Savannah River at Augusta the scouts entered South Carolina and found on the way to Aiken much improved sand-clay road. Aiken is also a famous Winter resort, whose most famous restaurant is conducted by the former chef of William S. Whitney. The road between Aiken and Columbia is mostly of sand-clay, but it has not received the attention it deserves and consequently is full of ridges where the ground is too high and full of holes where the surface is too flat. The first 15-



Innumerable fords were encountered by the pathfinders in the Carolinas

mile stretch out of Columbia was considered at one time the best example of sand-clay road in America, but this has been allowed to deteriorate, though one can still make excellent time over it. About half of the remainder of this road to Camden has been improved and work is still in progress. A new hotel at Cheraw furnishes first-class accommodations, supplemented by a complete garage and machine shop. From Cheraw to the State line one of the worst stretches of the trip is encountered.

Entering North Carolina the roads improve and continue excellent through Rockingham, a cotton manufacturing town with hotel and garage accommodations. A short stretch of narrow sandy road is encountered after one turns off the main road into the pine woods, but the last 15 miles, entering Pine-



The scouts arriving in Raleigh, N. C., on the fourth day

hurst, is the best trip thus far, due particularly to the fact that it has been dragged.

The direct road from Pinehurst to Raleigh is 81.7 miles, but, owing to the fact that little interest is manifested along this route the scouts were advised to go via Fayetteville. After passing through Harnet County one encounters some very poor narrow, sandy roads, but upon entering Wake County the road gradually improves and is fine as one nears Raleigh, the capital of the State, and famed as the birthplace of Andrew Johnson. After crossing the Neuse River a splendid new road is followed which though winding, is of excellent construction, and the 45 miles to Henderson is handily covered in 2 hours. From Henderson to Roanoke Rapids, a cotton milling town, the road is fair-to-good, but after crossing the Roanoke River, where a toll of 50 cents is exacted, a stretch of very heavy sand is encountered for about 10 miles. This is amply compensated, however, by the magnificent stretch of sand clay road from Barley to Emporia, a distance of 15 miles.

After leaving Emporia the old Coast Line right-of-way is followed for a short distance. Then comes a stretch of well-graded road which needs a proper dressing of sand-clay. Fifteen miles out begins the most wretched part of the whole Capital Highway, which extends 7 miles to Stony Creek. From Stony Creek the Coast Line right-of-way is followed into Petersburg.

The scouting tour was terminated at the Hotel Jefferson, Richmond, the car having covered 715 miles in less than 5 days, but would be more comfortably taken as a tour in 6 days. With the improvements now in progress and with careful driving the trip can be made in comfort in that time.



The railroad, the ox-cart and the automobile—three types of transportation exemplified

## Pope Stars in Phoenix Races

PHOENIX, ARIZ., Nov. 9—Two serious but not fatal accidents marred an afternoon of sensational racing at the Arizona fair grounds to-day. Harris Hanshue, of Los Angeles, and Fred Fuller, of En Centro, both driving Mercers, crashed through the fence but miraculously escaped with their lives.

Traveling faster than a mile a minute, Hanshue punctured the inner railing on the fourth turn of the mile track. When picked up by the attendants in a Red Cross truck, which was on the grounds, Hanshue was unconscious. An examination proved that he had received only a severe wound in the head, a strained hip and various bruises. There were no internal injuries. Fuller was only shocked. His car was a total wreck, but Hanshue's machine left the grounds under its own power.

Hanshue's accident occurred during the 10-mile handicap race for all the cars that participated in the Los Angeles-Phoenix road race. For several miles the Franklin and National were struggling for first place, then the Mercer moved up until it was just behind the National, which Ed Swanson, mechanic to Harvey Herrick, who won the Phoenix race, was driving. Hanshue took several long chances in attempts to swing in and grab the pole. While he was taking one of these chances the steering knuckle broke and the Mercer ramm'd a hole in the fence. Before he was thrown out Hanshue had time to jam on the emergency brake. He went in one direction and the car in another.

This race was won by the National, with the Franklin, driven by Guy Irwin, second. The other starters were: W. D. Tremaine, in the Pope-Hartford, Bill LaCasse, in the E-M-F, George Soules in the Flanders, W. F. Brong, in the Case, and Charles Bigelow, in the Cadillac. The National was the basis of handicapping. The Flanders was given 50 seconds start; E-M-F and Case, 30; Cadillac, 20; Pope and Franklin, 15; Mercer, 10.

Fuller's accident occurred during the 25-mile, free-for-all for cars with a piston displacement of more than 231 inches. Bert Dingley started in the racing Pope, Hanshue in his Mercer, Swanson in the Phoenix road race National, Fuller in the Phoenix racer Mercer, Frank Seifert in the National that won the Santa Monica race and Louis Nikrent in a Buick.

Fuller never figured as a possible winner, but drove a daring race. He took one chance too many and at the second turn crashed through the outer fence. He went up in the air several feet but came down in the disintegrating car.

The Pope got the best start but the National was close, with Hanshue's Mercer and the other cars strung out behind. Dingley ran the first 5 miles in 4:46.05; 10 miles, 9:30.36; 15, 14:19.17; 25, 23:52.96. The National was second with the Mercer a close third.

By far the most sensational race of the day was the 10-mile free-for-all. Mile after mile Dingley, in the Pope, and Seifert, in the National, struggled for first place. No prettier race ever was seen on any track. Dingley won easily, once he secured the pole. He did so only after many sensational trials and hair-raising escapes from collisions. Seifert got away first and hung to the pole. It was during the eighth mile that Dingley took the lead. This mile was covered in 52 4-5 seconds, and is said to have been the fastest mile ever made in competition.

Five cars started to beat the Phoenix track record of 56 seconds, held by the Apperson. Both the Pope and National succeeded. The Pope's time was 52 3-4 seconds and that of the National 52 4-5. Louis Nikrent covered the mile in 57.35 with his California Buick; Tom Carrigan, in the Midland, made it in

1:05.56 and William Ferguson, who drove the Arizona Buick, in 1:05.56.

With one exception the time of the Pope is the fastest ever made on the Pacific Coast over a mile circular track. The record is 51 4-5 seconds and was made by Barney Oldfield, with a 200-horsepower Blitzen Benz.

Four machines started in the 15-mile event for cars participating in the Phoenix race, having a piston displacement of 301 inches or over. There was a pretty struggle for first place between the National and Nikrent's Buick, but the National won. Its time for 5 miles was 4:57.55; 10 miles, 9:43.22; 15, 14:37.67. The Buick was second, with the Franklin third and the Midland fourth.

Hanshue was the hero of the 10-mile race for cars in the Phoenix race, having a displacement under 301 inches. At the start the Cadillac, driven by W. W. Bramlette, and the E-M-F, took the lead. The Mercer, Case and Cole, with John Jenkins at the wheel, were strung out behind. Soon it became evident that the Mercer was more of a factor than had at first appeared. Hanshue kept on the outer edge of the track and crept up, passing first the E-M-F and then the Cadillac. That happened during the fifth mile. Thereafter no interest attached to the race except for Hanshue's fast driving. Finally the E-M-F slowed up and was passed by the Case. They finished with the Mercer first, Cadillac second, Case third, E-M-F fourth and Cole fifth. The Cole was distanced, owing to a cracked cylinder. Hanshue's time for the 10 miles was 10:34.05.

There was a special event for the cars in the Phoenix race that arrived first, second, third and fourth, but W. D. Tremaine's Pope, which came in fourth, did not start. The National took the lead and easily held it to the end, winning in 10:15.56. There was a fight between the Cadillac and the Franklin for second place, but the Cadillac won out, taking the lead in time to beat its rival.

An attempt was made by George Soules, in a Flanders, to lower the world's 5-mile circular track record for 20-horsepower cars. The record is 5:42 but the best that Soules could do was 5:57.51.

### Entries for the French 1912 Grand Prix

For the combined international two-day *Grand Prix* and *Coupe d'Auto* race to be run in France in the Spring, over a distance of about 2,000 kilometers and under the management of the Automobile Club de France, the number of entries by any one firm of manufacturers is limited to 4. Unless at least 30 entries shall have been duly received on or before December 30, 1911, the event will be called off and the entry fees refunded. American as well as other nominations must be in the hands of the Sport Committee of the Automobile Club de France before the date mentioned accompanied by the regular fees, which are \$300 for one car, \$500 for 2, \$750 for 3 and 900 for 4. Thereafter, if the requisite number of entries for securing the event has been received and accepted, additional entries will be accepted at doubled fees up to March 31, 1912.

Cars of any preferred design, size and power may take part in the Grand Prix section of the event, excepting that the track width, from hub to hub, center to center presumably, must not exceed 1.75 meters.

If more cars are entered than can safely be run, in the opinion of the management, the Sport Committee reserves for itself the privilege of reducing the number by drawing lots or any suitable means.

# Hudson and Cadillac Win Harrisburg

**H**ARRISBURG, PA., Nov. 14—A Hudson, entered by I. W. Dill and driven by Roy Hamilton, won first prize in the dealers' class, and a Cadillac car, owned by W. P. Starkey, and driven by himself, won the first prize in the private owners' class of the Harrisburg economy run given yesterday by the Motor Club of Harrisburg, from Harrisburg to York. The cars before leaving on the 104-mile trip yesterday morning were sealed and upon their return last evening were opened by the technical committee and the amount of the gasoline consumed on the run was then recorded. The Hudson car consumed 5 gallons and 1-8 pint and the Cadillac car 6 gallons and 1 quart on the entire trip.

The cars left Market Square at Harrisburg and the pacemaker, a Pullman, in charge of E. G. Brandt and Referee Douglas, was the first machine away at 9:38. The others cars got away at 1 minute intervals and took up the course to York at a 16-mile an hour speed. The route of the run lay through Dauphin, Cumberland, York, Adams and Lancaster counties. After crossing the Susquehanna river and passing Camp Hill the machines went to Dillsburg, East Berlin, Abbottstown, Hanover, Menges Mills to York, where a stop of 90 minutes was made for lunch. At 2:18 the machines began to depart via Columbia, Florin, Marietta, Middletown and Steelton. The roads were in fairly good condition, the only hindrance being the cold. The cars checked in at Market Square at 4:45 o'clock. Seventeen cars carrying 70 persons were entered in the run and all finished the run with the exception of 2 cars that were withdrawn. Three cars met with accidents, which included the two Kline Kars entered by the Kline Motor Corporation. Up until the accidents, the cars had made an excellent showing.

The following shows the total fuel consumption:

No.	Car.	Entrant.	Gal.	Qts.	Pts.
5	Hudson	I. W. Dill	5	0	3/4
14	Cadillac	C. C. Crispen	5	1	1 1/4
4	Hudson	Murray Dick	5	2	1
6	Inter-State	I. W. Dill	5	2	1 1/4
13	Cadillac	H. D. Delmott	5	3	1/2
17	Cadillac	C. C. Crispen	6	0	1 1/4
15	Cadillac	W. P. Starkey	6	1	0
3	Chalmers	R. L. Morton	6	1	1/2
9	Flanders	E. L. Craft	6	3	1 1/2
16	Cadillac	C. E. Covert	7	2	1/2
19	Everitt	G. C. Furl	7	2	1
7	Chalmers	Ino. Gallagher	7	2	1 1/4
8	E-M-F.	E. L. Craft	7	3	1 1/4
2	Hudson	J. H. Benfer	8	3	0
11	KlineKar	J. A. Kline	8	3	1 1/4
12	KlineKar	J. A. Kline	Withdrawn		
18	Reo	G. G. McFarland	Withdrawn		

The awards were based upon the following cost per mile per passenger:

Class	Car	Cost
Class A, Touring Cars, \$1,000 and Under	9—Flanders	.00212
	19—Everitt	.00233
Class B, Touring Cars, \$1,000 to \$1,500	8—E-M-F.	.00242
	5—Hudson	.00154
Class C, Touring Cars, Above \$1,501	14—Cadillac	.00167
	6—Inter-State	.00175
	17—Cadillac	.00188
	15—Cadillac	.00191
	3—Chalmers	.00195
Class CC, Runabouts, Above \$1,501	4—Hudson	.00430
	16—Cadillac	.00531

## National Wins at San Antonio

SAN ANTONIO, TEX., Nov. 13—A three-day track meet run by the San Antonio Club, was completed this afternoon, the feature of which was a 4 1-2-hour race split into three sections of 1 1-2 hours a day this was won by a National, driven by Sutherland, the car covering 225 miles in the 4 1-2 hours. Second was a

Jackson, driven by Meleun, with 216 miles; third was an E-M-F, driven by Reeves, 213 miles; fourth was a Staver-Chicago, driven by Knudson, 203; and fifth was a Flanders, driven by Potter, 195 miles. Ten originally were scheduled to start, but the Cutting went out early because of a loose radiator, while the Flanders caught fire at the pits and was withdrawn.

Originally the meet was scheduled to start last Thursday, but the weather conditions were such that the 3-4-mile track was deemed unsafe so the actual racing was postponed to Saturday, continued yesterday and finished to-day. Before the start of the long grind each day there were short-distance races in which the Cino did especially well. The summaries of the three days of racing follow:

### FIRST DAY

Class C, Division 3C, Non-Stock, 12 Miles			
Pos.	Car.	Driver.	Time.
1	Cino	Raimy	13:49
2	Staver-Chicago	Monckmeier	
3	E-M-F.	Reeves	
Special Match Race, Five Laps			
1	Cutting	Clark	4:22 1/2
2	Jackson	Fred Meleun	
Class D, Non-stock, Free-For-All, 21 Miles			
1	Cino	Raimy	24:29
2	Staver-Chicago	Monckmeier	
4 1/2-hour Race, First Section (62 Min.)			
National, 72 laps; Ohio, 72 laps; Jackson, 71 laps; Staver-Chicago, 69 laps; Cino, 68 laps; Staver-Chicago, 66 laps; E-M-F, 63 laps; Pope-Hartford, 56 laps.			

### SECOND DAY

Class C, Division 3C, 9 Miles			
Pos.	Car.	Driver.	Time.
1	Cino	Raimy	9:53 1/2
2	Staver-Chicago	Knudson	
3	Staver-Chicago	Monckmeier	
Free-for-All, 15 Miles			
1	National	Sutherland	16:41 1/2
2	Staver-Chicago	Monckmeier	
3	Jackson	Meleun	
4 1/2-hour Race, Second Section (118 Min.)			
Total distance—National, 202 laps; Jackson, 195 laps; E-M-F, 187 laps; Staver-Chicago, 177 laps; Flanders, 171 laps. Leader's mileage, 152 1/2.			

### THIRD DAY

First Event, 15 Laps, 12 Miles, Class C, Division 4-C			
Pos.	Car.	Driver.	Time.
1	Cutting	Clark	12:56.20
2	National	Sutherland	
3	Jackson	Meleun	
Second Event, 24 Laps, 18 Miles, Class E			
1	Cino	Raimy	21:05
2	E-M-F.	Reeves	
3	Staver-Chicago	Knudson	
4 1/2-Hour Race, Third Section (90 Min.)			
1	National	Sutherland	225 miles
2	Jackson	Meleun	216 miles
3	E-M-F.	Reeves	213 miles

## Flanders Cars Break Class Records

INDIANAPOLIS, IND., Nov. 14—New records were established at the Indianapolis Motor Speedway yesterday. Frank Witt drove a Flanders Class B stock car in Division 1B, 160 cubic inches and under 1 mile in 56.80; 5 miles in 4:22.98; 10 miles in 9:27.49; 15 miles in 14:13.26; 20 miles in 19:00.87. Robert Evans drove a Flanders Class C, 160 inches and under, 1 mile in 56.80; 5 miles in 4:26.10; 10 miles in 8:53.95; 15 miles in 13:24; 20 miles in 17:54.80.

F. E. Edwards, A. A. A. technical committee, examined the cars, and the timing was done by the Warner electrical device. It was intended to go after 25 and 50-mile records, but the cold was too great for the drivers.

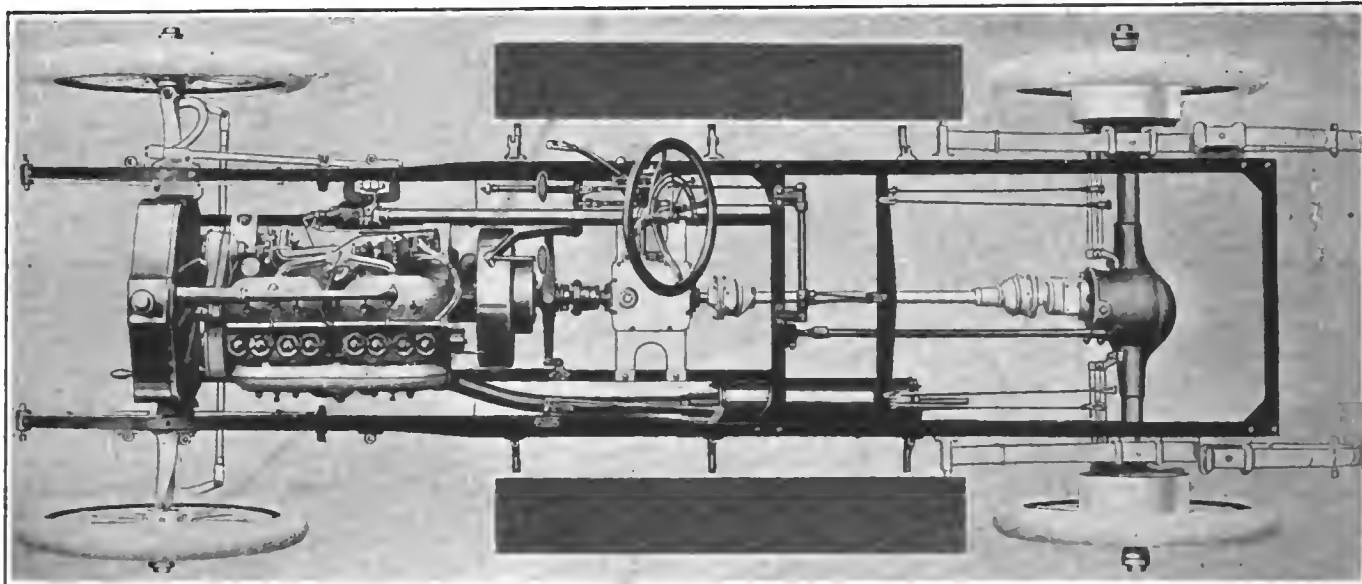

Fig. 1—The standard chassis used in connection with all models of the Selden line

## Selden Refinements for 1912

A SINGLE chassis features the Selden line of cars for the season of 1912. The various styles of body are fitted upon this chassis and the only change necessary in the constructive details when fitted with bodies of different types is in the steering columns and control levers.

The motor is rated at 40 horsepower and has a bore of 4 3/4 inches and stroke of 5 inches. There are four cylinders, which are cast in pairs with the valves all on the left side of the motor. All the valves are made interchangeable, having a diameter of 2 1/4 inches and a lift of 5/16 inch. A feature of the cylinder casting is that it is arranged with a web which forms the basis of a cover which serves to completely house the valve mechanism. The covers are easily removable by turning the hand screws, which may be seen at C, Fig. 3. The manifolds are held to the cylinders by means of the dogs and studs which are shown at D. A detail of interest is the manner in which the indicator P is attached to the engine frame so that the marks on the fly-wheel corresponding to the phases of the cycle may be easily read.

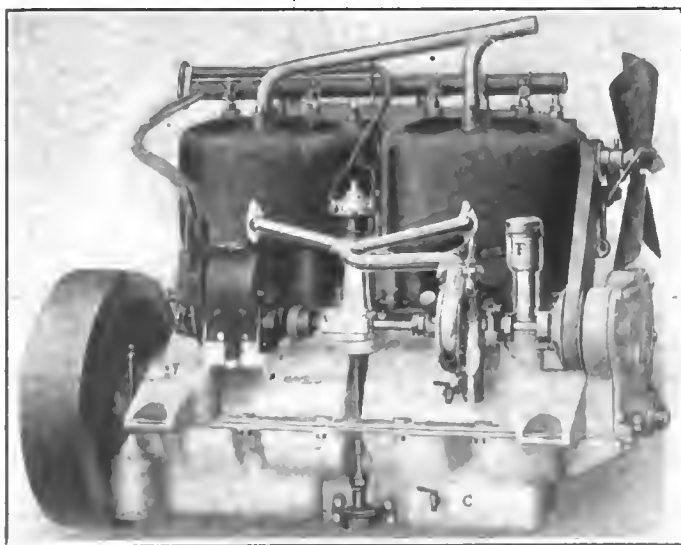

Fig. 2—Right side of the Selden 40-horsepower motor, showing the magneto and pumps

The motor is water-cooled, the cylinders being cast integrally with their water jackets, which have removable covers so that they may be readily cleaned when necessary. The water is circulated by means of a centrifugal pump located on the right side of the motor and driven by a horizontal shaft which is actuated by a set of gears contained in a housing at the front end of the motor. The water pump is of large capacity so that a sufficient supply of water will be assured at all speeds. There are baffle plates located within the water jackets so that the water will be directed to the most needed points and a reliable circulation maintained. The water is led to and from the radiator by means of seamless brass tubing, the end connections being made by using specially treated rubber. The square-tube radiator is kept cool by means of a six-bladed fan which is driven by a belt from the same shaft as that which drives the water circulating pump. The fan is mounted on ball bearings and is fitted with an automatic spring tension for the belt. There is a removable coupling in the shaft so arranged that it is very easy to take out and replace the belt without disassembling any other parts of the motor. The crankshaft is a drop forging of nickel steel specially heat-treated. It is carried upon three large plain bearings which are lined with die cast soft metal.

The camshaft is of the built-up type; that is, the cams are machined and hardened separately and then pinned to the shaft in their proper positions. In case of an injury to one of the cams it may readily be removed and replaced without tearing down a large part of the assembly.

The valve push rods are of the mushroom type, acting directly between the cams and the valves. To render desired adjustments easily possible, screws are fitted by means of which any wear may be taken up. The push rods act in guides, which tend to reduce chattering and rapid wear in the valves and the other parts of the valve action. The push rods and their guides are so constructed that they may be readily removed without interfering with any other part of the valve or engine mechanism.

The carburetor is carried on the left side of the motor; it is of the Stromberg double-jet type and is fitted with a hot-water jacket. The gasoline feed is by gravity and is governed by float and needle valve in the carburetor. The gasoline tank is located beneath the driver's seat and has a capacity of 17 gallons.

There has been no change made in the ignition system of the

new car, the Bosch magneto, type DR-4, being used in connection with one set of spark plugs, while an independent battery system is connected to another set of plugs. The spark coil is of the master vibrator type in which there is but one vibrator, so that a uniform spark will be supplied to all the cylinders. As there is a cut-out button on each of the coils it is possible for the operator to at once determine the location of a misfire. All the coil units are easily removable from the casing, which is hinged for this special purpose. Current for the coil is supplied by six dry battery cells located on the running board.

The motor is lubricated by means of a splash system in which the oil is maintained at constant level. The oil is carried in the lower part of the base casting, which is so arranged as to carry both the reservoir for the oil and the troughs by means of which the splash system of lubrication is operated. The lower part of the casting in which the oil is carried has a capacity of 6 quarts and is separated from the upper part of this casting by means of a horizontal tray which carries the splash troughs. There is one of these troughs below each crank throw. The oil is lifted from the reservoir by means of a gear pump which takes the lubricant from the base and puts it into the troughs. The pump is driven by means of a vertical shaft which is actuated by the horizontal shaft driven by the gears at the forward end of the motor. The timer is located at the upper extremity of this shaft, while the oil pump is at the lower.

Besides pumping the oil from the reservoir to the troughs the oil pump also sends it through a lead to the timing gear case, thus insuring ample lubrication at all times. After having lubricated the gears, the oil will drain back to the crankcase. The oil in the troughs is picked up by the ends of the connecting rods and thrown up into the cylinders, which are thus lubricated. The beating action of the connecting rods into the pools of oil formed in each of the troughs churns the oil into a fine spray or mist which pervades the entire crankcase, thus lubricating all the moving parts therein contained. The pump is continually supplying the oil to the troughs at a much more rapid rate than it is being consumed; hence there will be a continuous flow through the overflow ports back into the reservoir. To prevent any accumulated foreign matter from passing through the motor after the oil has once carried it down to the reservoir, there is a screen provided through which all the oil must pass. This screen is inserted in the path of the oil to the pump.

The reservoir is filled through the filler hole F, Fig. 2, which is located on the right side of the motor near the front. It is covered with a screw cap and is fitted with a screen through which the oil must pass. The amount of oil within the crankcase may at all times be determined by means of the ball gauge which is located at the front end of the motor on the right side. The

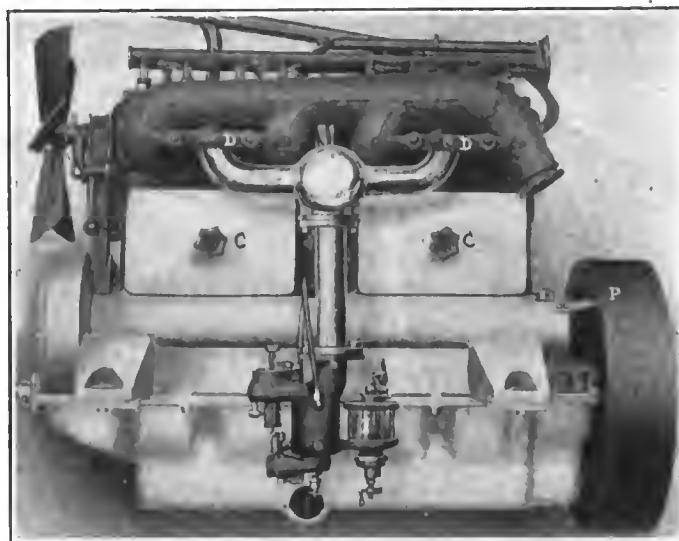

Fig. 3—Left side of the Selden motor, showing the location of the carburetor and manifolds

ball riser is of steel and its position may be ascertained by the hand in case the car is in darkness at the time the oil level is to be determined. If there is so much oil within the crankcase that it causes the motor to smoke, the drain cock C in the bottom of the crankcase may be opened and the excess oil allowed to run out.

The clutch is of the multiple disc type, and is enclosed in a housing which is bolted to the flywheel. There are thirteen discs, the driving members being faced with an asbestos composition which is riveted in place while the driven discs are left unfaced. The inner or driven housing holds a pair of heavy spiral springs which supply the necessary pressure. The tension on the springs may be regulated by means of a pressure plate and three studs which extend through the plate. By means of these studs the required adjustments may be made without the removal of any housing or other parts. An automatic spring lock secures the studs and prevents them from turning.

A universal joint of the gear type, consisting of a pinion on the transmission shaft inserted in an annular gear of equal size, connects the clutch with the transmission and allows sufficient lateral play to permit of the clutch being readily thrown out of engagement without any rattle or lost motion. The transmission bearings are so arranged that any thrust due to throwing out the clutch is taken up by them, relieving the motor entirely of this duty. To prevent the clutch from spinning when changing

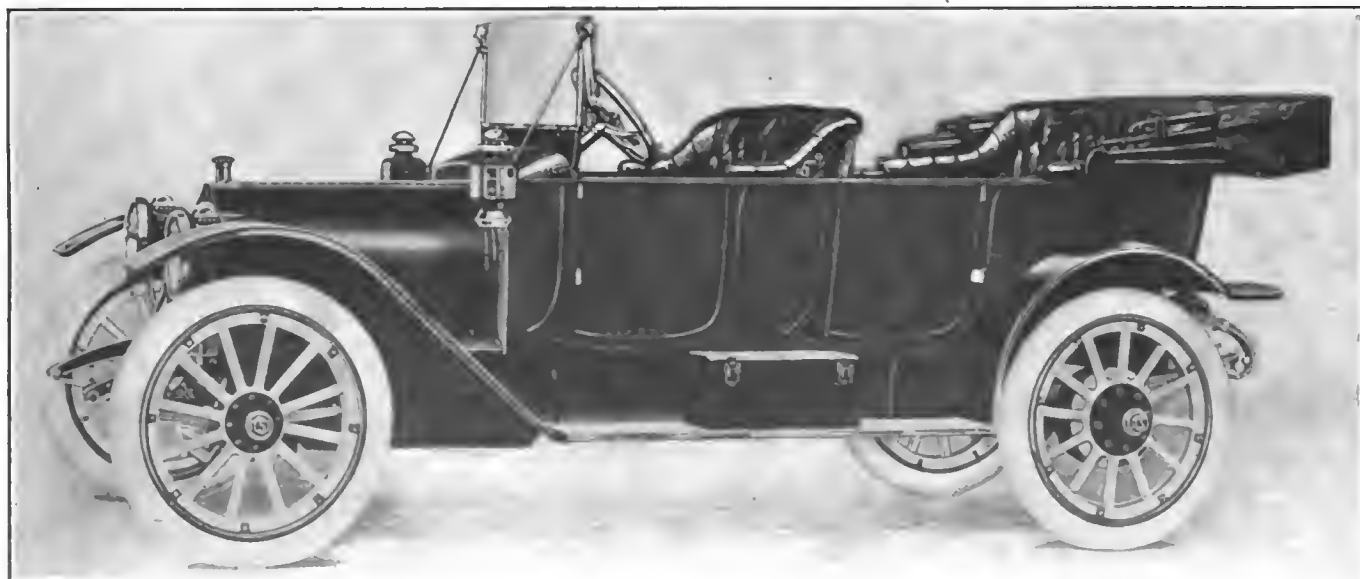

Fig. 4—The Selden model 47 is a fore-door, five-passenger touring car of roomy dimensions



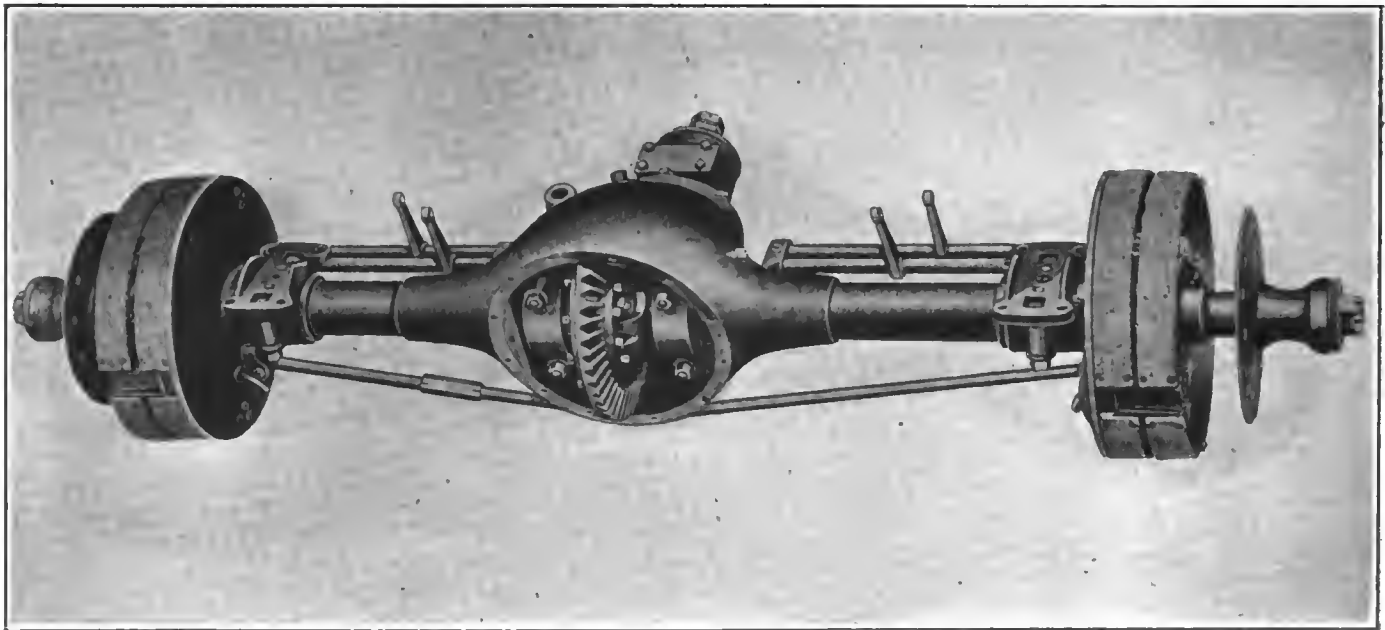

Fig. 5—Illustrating the rear axle of the Selden cars with the differential cover removed

gears, a brake is fitted, thus aiding in this important operation.

Connected to the clutch pedal by a system of levers is the ball thrust. The levers and thrust are so arranged that a light pressure on the pedal will be sufficient to manipulate it. The emergency brake is interlocked with the clutch so that when the brake is applied the clutch will be disengaged, although if it is so desired, this interlocking device may be readily removed. The clutch may be easily disassembled by the removal of a few bolts so that repairs may be simply and readily made when necessary or inspection facilitated.

The gearset is of the sliding selective type with three speeds forward and one reverse, high speed being on direct drive. The shafts run on Timken roller bearings which are adjustable for wear from the exterior of the case, and hence when any adjustments are necessary it will not be required to dismount any of the mechanism. The gearset housing is an aluminum casting which is carried by the subframe by means of four supporting arms which rest upon the top of the frame. Inspection is made readily possible by means of a cover which may be removed without disturbing any other parts.

The power is transmitted from the gearset to the drive shaft through a universal joint of the Spicer type. The drive shaft is also fitted with a Spicer universal joint at the rear end through which the power is transmitted to the differential.

The rear axle is of the floating type. The drive pinion runs on New Departure ball bearings while the differential housing is mounted upon Hyatt bearings with ball thrust. The differential is provided with a cover which is very easily removable so that the entire mechanism may be exposed for purposes of inspection or repair. The axle shafts are provided with flanges through which the hub bolts pass, the chances for lost motion occurring at this point thus being reduced to a minimum, and at the same time the hub caps are relieved of the duty of holding the axles in place. To prevent the oil from leaking into the brake drums and causing them to slip at some time when they are required to take hold quickly, sleeves are fitted on the hubs which lead any oil that may work out along the axle shaft, into an annular recess in the brake flange, whence it is drained out on to the road. The brakes are of the internal expanding type and are of ample size, the bands being 1 3-4 inches wide and 14 inches in diameter, acting directly upon the rear wheel. The brake shoes are fitted with non-burning material and are set side by side, as may be seen in Fig. 5. The rear axle housing is stiffened by means of a tie rod.

The torsional strains in the rear axle are taken up by a triangular torsion arm of heavy gauge tube steel with drop-forged

ends. The stress is transmitted to the central cross member of the frame, which is fitted with a bracket supporting the housing that encloses the front end of the torsion arm and the heavy cushion springs. This housing is made tight in order to exclude all mud and water and may be packed in grease to prevent rattling or other noises at this point. The torsion arms are attached to the axle by means of two short vertical pins.

The front axle is a one-piece drop forging of I-beam section while the frame of the chassis is of channel steel 4 3-4 inches deep and 3-16 inch thick, with three cross members and a sub-frame which supports the motor and gearset. The frame is raised over the rear axle and so shaped as to allow the use of 3-4 elliptic springs. The rear springs are 51 x 2 1-4 inches. The frame is brought in at the front end in order to provide for an easy turning radius. Semi-elliptic springs are used in front. They are 38 x 2 inches.

The wheels on all the bodies are similar, being of wood 36 x 4 inches all around and are fitted with Firestone Q. D. rims. The bearings upon which the wheels are carried are of the ball type, the rear wheels being provided with New Departure bearings containing two sets of balls, while the front wheels are fitted with adjustable bearings of the cup and cone type. The wheelbase for all models is 125 inches, while the tread is the standard 56 inches. The road clearance is 10 inches.

The steering gear is of the worm-and-gear type, which may

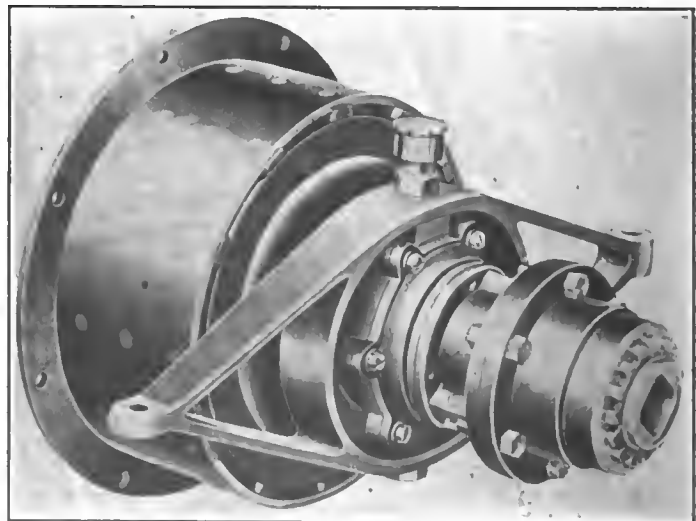

Fig. 6—Showing the dry disc type of clutch employed with all models

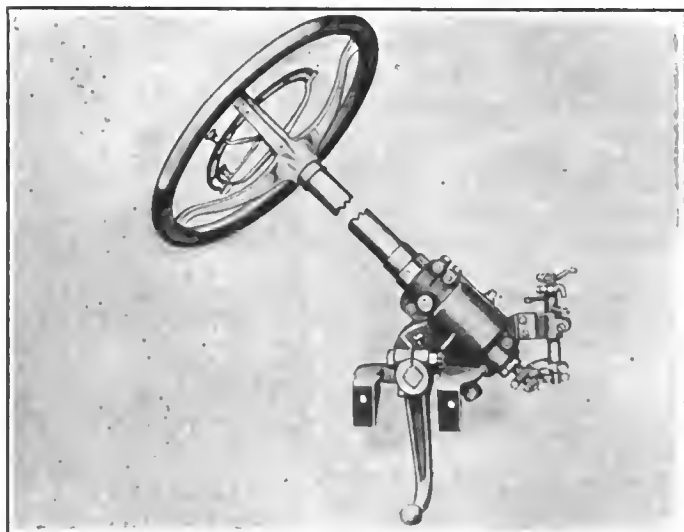

Fig. 7—Condensed view of the steering gear and housing

be so adjusted that four different bearing surfaces are brought into contact with the worm. This method of arrangement will tend to increase the life of the steering parts, as an adjustment may be made from time to time to insure a different part taking up the wear. The steering gear housing is bolted to both the main frame and the subframe in order to secure a stiff and rigid connection. The steering column housing is carried down to the gear casing and connected thereto.

The steering wheel is 18 inches in diameter. The frame of the wheels is of cast aluminum and this is built into a wooden rim of large oval section so that easy grip is secured upon the wheel. The spark and throttle control levers are placed in the center of the wheel on their respective quadrants and held thereto by means of spring catches.

The muffler on the new model car is of the same size as that used in previous years on the Selden cars, but in order to secure a freer exhaust the cut-out valve has been enlarged. A change has also been made in the manner in which the exhaust pipe is supported. The fastening has been so strengthened as to increase the security of the connection, thereby holding the pipe firmly against the vibrations of the car. The mechanism which controls the action of the cut-out has also been completely redesigned.

The foot accelerator, which is fitted to all models, is of the

push-button type; it is within easy and comfortable reach of the foot so that the driver may readily operate the car entirely by the manipulations of his foot upon the accelerator pedal.

The head lamp bracket sockets are riveted upon the frame of the car; they are heavy drop forgings and are connected by a tie bar to maintain rigidity. The side lamp brackets are connected to the dash board and carry the front ends of the windshield stay rods.

Another feature which has been changed in the new cars is the length of the running boards, which has been increased to conform to the dimensions of the larger cars. They are now carried upon three step hangers instead of two, so that a stronger connection is maintained. The running board carries the gas tank for the lighting supply and the opposite running board carries the battery box.

A full supply of lamps goes with each model. The head lamps are operated by gas and are supplied by the tank upon the running board; the side and tail lights are a combination of electric and oil. The current for the lights is supplied by an 80 ampere-hour storage battery which is contained in the battery box upon the running board.

The standard equipment furnished with all the cars also includes a top, complete with all curtains and envelope, windshield, battery box, tool box, horn, robe rail, foot rail, muffler cut-out, tire irons and a complete set of tools.

The types of bodies furnished with the new chassis are of five different varieties. The model 47 is a five-passenger touring car of the fore-door type. Model 47-S is larger, being classed as a seven-passenger touring car, likewise of the fore-door type. Model 47-T, known as a four-passenger torpedo, is built along racy lines and is adapted for four people, being of long narrow construction. The 47-R model is a two-passenger roadster with a rumble seat, making the carrying capacity three; this car is also constructed with the idea of presenting a racy appearance and is designed to meet the requirements of those who do not need a larger car. The limousine, which is known as model 47-L, is of large dimensions, being constructed for a seven-passenger capacity; the aluminum body is of special design and will accommodate five passengers in the rear compartment while the front seat will accommodate two. The limousine body, as well as the chassis and running gear, will be painted in standard blue or Brewster green and will be trimmed in broadcloth or cord to match.

The equipment of the limousine will include a divided glass front, removable cab sides, side curtains, two extra swing seats, foot and robe rails, dome lights, toilet case and umbrella holder.

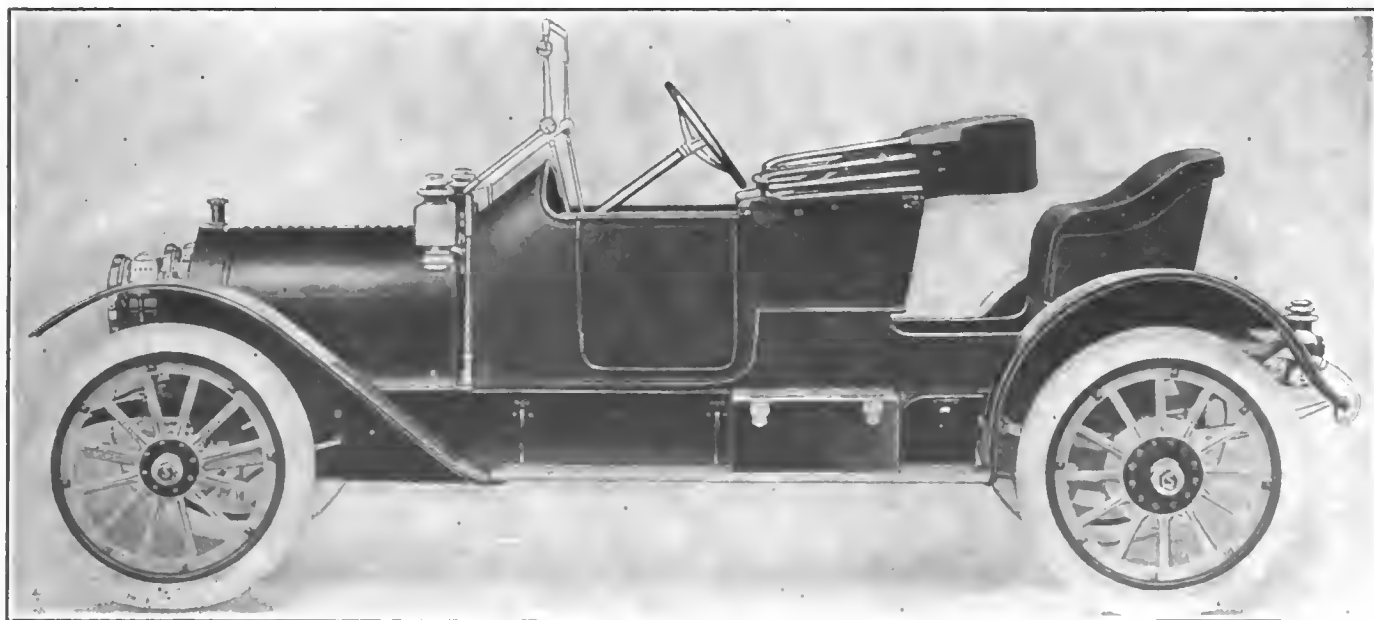

Fig. 8—The 47-R model, a fore-door two-passenger runabout with a rumble seat

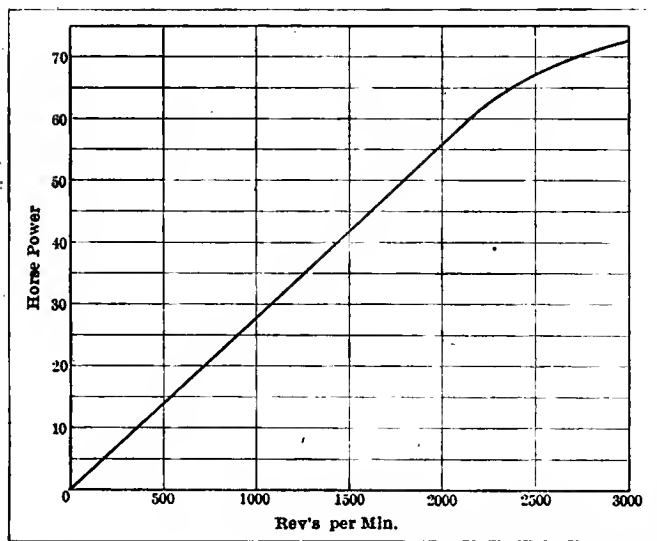

Fig. 1.—Power curve of a 3.3-inch motor, showing a remarkably steady rise

## Engine Efficiency

AS an indication of the difference between the average stock model and the car that is specially prepared for racing purposes some figures recently published in England by the Austin Motor Company show what can be attained in the way of efficiency by special fittings to the motor. The piston speed of a motor is dependent in a measure upon the weight of the reciprocating parts, and it has been the aim of designers to make these as light as possible consistent with the stresses and strains they are compelled to undergo. Pressed steel has been adopted of late years for the pistons on some racing motors, but one disadvantage of this method of manufacture lies in the fact that out of a dozen blanks several are often found to be faulty. This enhances the initial cost and would be too dear a proposition for stock cars. However, when the cost is not a matter of importance there is no doubt that the steel piston is lighter than the conventional cast gray iron variety.

The pistons of the motor under consideration were steel and together with their wrist pins and rings weighed 1 pound each. Connecting rods weighed 1 1-2 pounds each and the motor was a four-cylinder monobloc with a bore of 85 millimeters (3.34 inches) and a stroke of 115 millimeters (4.527 inches).

The power curve of the motor shown in Fig. 1, which is reproduced from *The Autocar*, indicates a remarkably steady rise up to 2,300 revolutions per minute, when it falls off only very slightly and continues to 3,000 revolutions, registering 72 horsepower at that speed.

Fig. 2 shows the possible speeds of a car fitted with this motor. The gear ratios are as follows:

First speed..... 9.7:1      Third speed .....3.9:1  
Second speed .....5.0:1      Fourth speed .....3.0:1

The ignition used on the motor under test was one that gave two sparks at the same moment, and two carbureters were employed.

### Two Sets of Advice on "Knocking"

When the well-known knocking sound is heard from the automobile, and it cannot be ascribed to loose connecting-rod bearings, several other possible causes may be looked into. The staybolts of the magneto may have become loose, in which case the magneto is likely to rock on its bracket and produce the sound of knocking.

A tooth in the camshaft gearing may have been broken.

The fan belt, if one is employed, may strike against one of the fan blades.

The hood may be loose and knock against its support or against the radiator.

An exhaust pipe joint may be loose, and the exhaust will then regularly produce a sound similar to that of a crankshaft knock.

The valves may be noisy, by the design of the valve cams or too much play in the valve lift mechanism.

The joint of an inlet pipe may be loose, causing too much air to enter the cylinder affected, and this will cause real knocking, even if the connecting rod bearings are tight.—From *La Pratique*.

The same subject is treated in another publication at greater length and, as it seems, with some variance in the diagnosis of the trouble. This doctor says:

The knocking may come from the crankshaft bearings, from the camshaft bearings and from the camshaft gears. The location of the cause can in these cases only be decided by a complete dismantling of the motor. It is better to look for other possible causes first. A badly seated valve or too much play in the valve control may be at the bottom of the trouble. Next, the flywheel should be examined; it may be rocking on its keys. A fouled or cracked spark plug or a poorly connected wire may be at fault. An experienced driver, however, will have no trouble in distinguishing the noises from the ignition or the carburetion system from real knocking.

If the knocking comes really from the motor or the flywheel, it continues of course if the motor runs while the clutch is out, and this is the way to try it.

If there is knocking with the change-gear lever on neutral and the clutch in, and the knocking stops when the clutch is disengaged, the cause is necessarily in the clutch, the intermediate shaft or the primary shaft of the transmission. The latter may knock from wear of bearings or when it has become misaligned with the motor shaft through twisting of the vehicle frame. Such misalignment will soon ovalize the bearings, and it is therefore of no use to remedy the knocking by relining these, unless the misalignment of the frame is first corrected. The ever extending use of a universal joint between the clutch and the transmission box now almost eliminates this cause from the possibilities by rendering a misalignment harmless.

The intermediate shaft comprises sometimes a bearing mounted in one of the cross girders of the frame. There, too, if there is misalignment, knocking may follow. And these forms of knocking, as well as those arising from a too stiff or too loose clutch, be it a metallic Hele-Shaw or Mercedes band clutch or a leather-

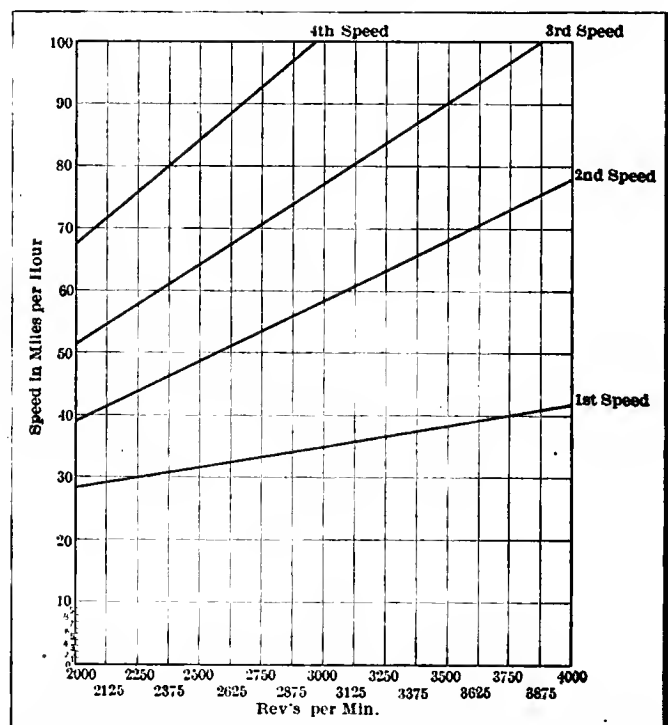

Fig. 2.—Diagram showing the speed in miles per hour of a car fitted with a 3.3-inch bore motor

faced cone, resemble closely that from a loose connecting-rod bearing. In the case of the Hele-Shaw clutch, shortage or excess of oil or even only the poor quality of oil is sufficient for producing the same effect. The remedies are obvious.

Suppose that one hears the knocking while the vehicle is running, but that it ceases when the vehicle is stopped and the motor turns without load. It may be that the motor is nevertheless the cause. Some motors knock even when everything is in normal order, as soon as the spark timing is no longer in accordance with the motor speed; but, barring this exceptional case, the sound must come from the transmission, from the driving shaft or from the brakes. The sound in these cases is an entirely different and much less frequent one. Its origin may be found by raising the rear end of the vehicle, resting it on a box for example, and running the motor. By engaging the different gear speeds successively and applying the brakes while immobilizing one wheel and then the other, the trouble is soon located. And, if only an adjustment is involved, as in the case of the brakes, it is also soon remedied.—From *La Vie Automobile*.

## Motor Gangploughs

WHILE the makers of continental Europe seek inspiration for the development of agricultural motor machinery in the productions of England and the United States so far as machinery of high cost and high power is concerned, which is best adapted for agricultural operations on a large scale, it is found in all countries that the development of machinery which can be used with real economy by farmers controlling only a limited acreage (and that usually of high price), represents a separate problem or rather a series of separate problems. It has been found especially difficult to devise gangploughs which will do the heavy work demanded of them, under all conditions of surface, soil and weather, with the limited power and small weight of the equipment which are indispensable features for keeping the first cost as well as the cost of operation and maintenance down to a practical minimum.

Professor Dr. Strecker of Leipsic reviews the main construction features in the machines which have been offered in the market with a view to the solution of these difficulties and with special reference to machines driven by gasoline motors. The English Ivel-Motor, weighing 1,500 kilograms and equipped with a 20-horsepower motor, has been found too weak for the work of drawing gangploughs, depending for traction as it does on chain-driven rear wheels alone. The French Bajac tractor of 25 horsepower is designed to draw a three-share plough weighing 1,100 kilograms. In light soil 2 1-2 hectares (6.178 acres) can be worked 20 centimeters (7.8 inches) deep in 10 hours with a consumption of 60 liters (13.2 gallons) of benzol. With a two-share plough weighing 1,000 kilograms 1 1-2 hectares of similar soil have been worked 36 centimeters deep using a slightly smaller amount of fuel. The possibility of deep ploughing under less favorable soil conditions is secured by a winch with a cable capacity of 200 meters. If the soil is so heavy that the motor cannot move the tractor and the plough at the same time, the tractor moves ahead alone unwinding the cable which has been attached to the plough, and, when as far as 200 meters ahead, it is halted and anchored by means of suitable brake arrangements, and then the plough is drawn to it by switching the motor power to the winch. This machine has three gear speeds, the high giving 15 kilometers per hour or 4 meters per second. The cable is wound up—drawing the plough—with a speed of 1 meter per second. The cable can of course also be used, in case of necessity, for pulling the tractor alone out of a slough or mire.

The Deutz gangplough weighs 8,000 pounds and operates four shares. Two plough beams each carrying four shares, are suspended from the machine, one in front and one at the rear. Only one set is in operation at one time, the arrangement having for its object to avoid the onerous and difficult turning of the whole equipment at the end of the furrows. By means of a provision



The Stock-motor plough, in use on many large German estates

for placing both pairs of wheels askew, the machine can be moved laterally the width of the work, whereafter the shares which were in front are let down and the machine moves in the opposite direction, the driver's seat being reversible. When the work is too heavy for the wheel adhesion, a cable is strung across the length of the field being attached to special anchoring vehicles at both ends and passed several times around pulley sheaves on the machine. Ordinarily these sheaves revolve idly, but when necessary for drawing the load they are switched into gear with the motor, and the machine then pulls itself and the plow slowly forward by this means, as a chain steamer draws itself up against a swift current by means of the chain laid down in the river. The equipment costs 27,000 marks and has not yet found extensive employment, though in trials which were held under favorable conditions it proved economically satisfactory.

The Stumpf motor plough weighs 12,000 pounds with a motor of 60 horsepower and a four-share plough and costs 38,000 marks. Traction is secured by broad and large driving wheels to the circumference of which are attached four rows of leaf springs, each spring secured at one end and extending almost tangentially and carrying at the free end a shoe or block which bends the spring to conformity with the rim when it strikes the ground—a system which, it seems, would be liable to be clogged up in wet and sticky soil.

The most interesting and strictly German development is shown in the "Stock-motor" plough which is in use on about forty German country estates and seems to be looked upon as very satisfactory. (The *Automobil Welt* states that it is little known only because the company manufacturing it is averse to all publicity with regard to its construction features.) The motor and the plough are built into a single frame. The 4-cylinder, 42-horsepower motor is mounted considerably in front of the two driving wheels which are over 6 feet in diameter and provided with traction blocks. The driver sits on the plough and alone attends to driving, steering and regulation of the plough-shares of which there are six. At the extreme rear a single steering wheel serves to determine the depth of the ploughing (apparently by adjustment of its height in relation to the plough frame), while the driver seems to be able to raise each individual share from his seat. The width of the work is about 5 feet and the machine is capable of turning over from 2 1-2 to 3 morgen (a morgen is 0.631 acres) of land every hour at a depth of 30 centimeters (12 inches), and the fuel consumption is figured as 4 kilograms (5.7 liters) of gasoline per morgen, which equals 2.06 gallons per acre. The price of the machine is 15,000 marks and it is said that it works well on hilly ground while still leaving something to be desired where deep ploughing of very heavy soil is wanted.—From *Automobil-Betrieb*, Oct. 15.

MORE BUSES IN LONDON—Ten automobile omnibuses form the average weekly addition to those already in service on the streets of London. Cah horses are being sold off at the rate of 200 every two weeks, and within the next year it is believed that the horse will be entirely supplanted by the motor bus. The latest available figures show about 1,500 buses in service and 1,600 horses.

# The Runabout as an All-Winter Car

WHEN a number of automobiles form the complement of a private owner, that justly popular and handy type of little car known as the runabout is sure to be included. When it is the only car in the owner's garage it is frequently compelled to do duty usually reserved for larger cars. It is in its character as an 'all-round car that this article has to

deal. The runabout is essentially a car for the business man's personal use; the ever-ready means of locomotion for the physician, while for suburban use it is made to do all kinds of work, from hauling baggage to and from the station, to carrying its owner and his family to an evening reception.

With the modern runabout the power is generally in excess of the actual requirement, and there is no good reason why an ideal Winter car cannot be made of it by the addition of a complete coupé body, or by adding the necessary upper structure to the body already on the car in order to get the coupé effect. The additional weight will range from 200 to 400 pounds. Some excellent effects can be arrived at if care is exercised in changing a runabout to a coupé. The design should be harmonious with the original parts of the body, and in changing the car it should always be borne in mind that when Summer comes around again the body must be put back in its original shape.

The method employed to effect the change is illustrated on two styles of runabout bodies, three designs being set forth. In Fig. 1 is shown an ordinary runabout body, while in Fig. 2 the same car is shown with the seat removed and a coupé body placed in position. The place that is left free by the removal of the seat is the principal support for the coupé body, the width of which is such that the sides come over and outside of the runabout body and enclose the levers. The dash is of one piece with the body, the original dash being removed. At the rear the coupé body fits close down to the deck, and at the lower part of the sides a metal strip is fastened to the coupé rocker, extending in to the runabout body and closing up any gap through which cold air might otherwise enter.

The coupé is really an envelope over the runabout chassis, the doors permitting of easy entrance from either side, while the glass frames can be made to drop if desired. It is recommended, however, that the door glass only be made to drop and the front glass made to swing outward in order to get the rain visor effect. The side and rear glass frames should be stationary to insure protection against cold and possible rattling. There is ample seat room for two passengers, while a fold-up emergency seat could also be installed, the latter being on the left side only. When in use its occupant sits crosswise of the car and leans against the door; when not in use the seat folds up under the cowl as indicated by the dotted lines in Fig. 2. The body as illustrated in this figure has upper panels of wood, the lower panels be-

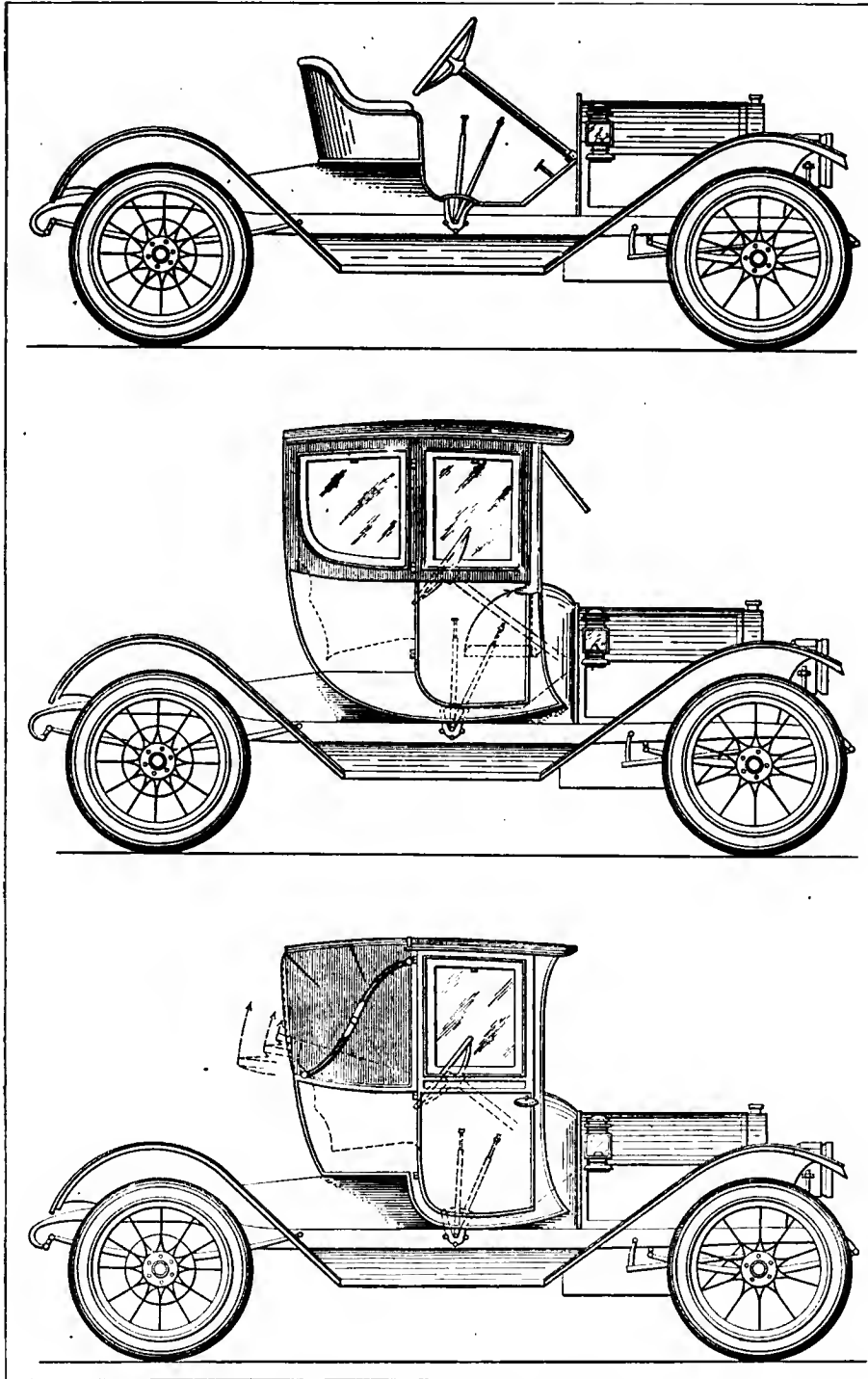

Fig. 1—Showing an ordinary type of runabout with open body

Fig. 2—Same car with seat removed and fitted with a coupé body

Fig. 3—Semi-collapsible landaulet body fitted to the same car



ing of metal. The framing is also of wood. It should be made as light as possible, not only to facilitate removal and replacement as the seasons change, but also to prevent overloading of the car, excess weight for a body of this description being in the nature of a crime, for it must be remembered that, especially in the rural districts, the service demanded of the transformed car calls for long trips over roads which are at their worst when the car is most needed.

In Fig. 3 is shown another type of body that can be fitted to the runabout shown in Fig. 1. It is a semi-collapsible landaulet, and the rear part of the top falls as indicated by the dotted lines and arrows. When not in use this top leaves the body open from the back of the door. The dimensions of the body and the seating will be the same as in Fig. 2; the door frames can be dropped, and the front glass raised to secure proper ventilation when the weather is not too inclement.

The possibilities of body designs that can be grafted onto the runabout are limited only by the will of the owner. Almost any design can be made to look well, but the best effects are gained where the entire body is put on as illustrated in Figs. 2 and 3.

In Figs. 4 and 5 are shown a regular fore-door runabout before and after the imposition of an upper structure that converts it into a coupé for Winter use. In this combination design the entire lower body remains, the upper or cab part being built to conform to the shape and design of the original body. It is attached at the top line of the seat door and cowl. The door is made continuous by this joining, and the two parts are made to work as one. The hinges must be in perfect alignment, and the regular lock on the lower part is fitted with an outside handle.

In making this upper structure care should be exercised to have it conform to the shape of the lower body; in fact, it is hardly possible to make it except by using the lower body as a pattern. It is constructed of a light wood frame with aluminum panels and mouldings. The side and rear glass frames are stationary, but the front glass can be swung out, as is the usual custom with closed bodies, and the door glass can be lowered a few inches for purposes of ventilation.

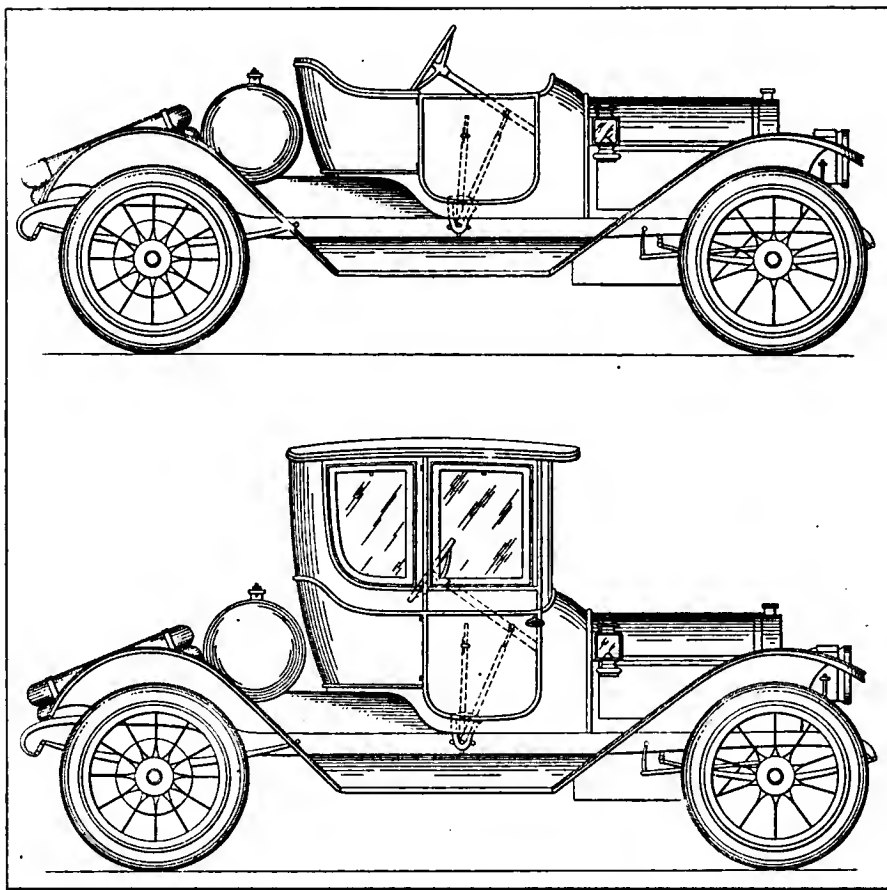

Fig. 4—Ordinary type of fore-door runabout for warm-weather use  
Fig. 5—Same car after upper part has been added to convert it into a coupé

The seat room for passengers should be about the same as that allowed in Fig. 2, and the use of a small fold-up seat is generally an advantage in all bodies of this type. The finish of the upholstery and the inside trimmings should conform to that on the runabout as it came from the factory, but it should be as light and as plain as possible on the new part of the body. The trimming on Figs. 2 and 3 should be of cloth, this material being much more comfortable for Winter use.

There are now on the market several other methods of converting an open-body car into a closed one—by the use of curtains, for instance—but the most satisfactory arrangement is something along the line illustrated, as this gives a substantial enclosure that will resist rain, and that will allow of entrance and egress without sliding under dripping curtains.

### Europe's Governments Subsidize Automobiles

Continental European Governments are taking a deep interest in the development of the automobile, a fact which gives great encouragement to manufacturers. This applies particularly to motor trucks, the owners realizing that if they would obtain a subsidy, they must maintain and operate the trucks in such a manner as to get at the accurate cost of such work. Besides, owing to the subsidy in question, manufacturers are careful to build their motor-trucks under direct supervision of technical representatives who are assigned by the War Departments of the respective countries. The respective Government then contributes a sum equivalent to \$1,000 for the initial purchase of the car, \$250 yearly, for five years, towards the operation and maintenance of the truck which will be turned over to the government in the event of war.

### Mexico Doubles Automobile Imports

The demand for foreign-made vehicles of various kinds is rapidly growing in Mexico, as is shown by the annual report of importations which has just been issued by the federal government. During the fiscal year 1910-1911, ending June 30, vehicles were imported to that country to the value of \$9,062,679 as compared with \$5,754,194 for the preceding fiscal year, an increase of \$3,308,484. It is claimed that but for the revolutionary disturbances which caused a general suspension of business for several months the importations for the last fiscal year would have been much larger. The present year promises a very material increase. The growing values of the vehicle importations is due largely, it is said, to the increase in the demand for automobiles. While these cars are purchased largely of American manufacturers good orders are constantly going to Europe.

# Digest of the Leading Foreign Papers

## Flame Leaks and Their Causes

ON the first Prince Henry Tour in Germany in 1910 one of the cars belonging to B. von Lengerke, an engineer, took fire while going at full speed and its owner took pains not only to examine into the causes of the occurrence, but also to look up the circumstances attending all other fires affecting automobiles and aeroplanes which came to public notice thereafter. He arrived at the result that in by far the greatest number of instances the carbureter bore the blame, or at least was instrumental in propagating the flame and igniting the grease and lubricating oil usually allowed to accumulate in greater or lesser degree in the drip pan under the motor where a fire is particularly difficult to extinguish.

Relating the result of his investigations the author states that a considerable number of aeroplanes have taken fire when the motor was started, in addition to those well-known instances where it broke out while the aviator was in flight, and in all these cases the cause can have been none other than a tongue of flame slipping out from one of the combustion chambers and reaching the vapors in the carbureter. All the causes which may be assigned for this occurrence may be generalized as one, namely, the momentary failure of the inlet valve to lock the fire within the cylinder. Ignition may take place before the inlet valve has been closed, or the inlet valve may be opened before the exhaust has been completed and while flame-hot gases are still present in the cylinder head.

This may be due to a momentary sticking of the inlet valve, or else to a peculiar design of the cams, meant to reduce valve noise in high-speed motors, in conjunction with over-advancement of the spark, and in this connection it is worth noting that carbureter fires were very frequent on the Prince Henry Tour of 1910, in which scarcely any cars participated that were not equipped with motors with a very high number of revolutions per minute, and that these occurrences were explained, not only by the author but also by other professional automobile engineers of high standing, as due to the extreme reduction of the time intervals between the motor periods, in some instances amounting to overlapping. At 2,400 revolutions per minute or more, designers experience the greatest difficulties in providing for precision in the reciprocating valve movements, as perfectly well known, and every factor which may retard or obstruct these movements may lead to the liberation of a tongue of flame.

As other possible causes for the phenomenon, leaking valves and sudden defaulting in the gasoline supply may be mentioned. A clogged jet, for example, may cause a very weak mixture whose ignition and combustion are likely to be so much delayed that the explosion period of the motor will blend into the exhaust period, with the consequence that, at the end of the latter when the inlet valve is again opened, high-tension gases still remain in the cylinder head.

With reference to fires which have been occasioned by starting of the motor, it is evident that the backfiring which is by no means uncommon when motors of high power are started (though the explosion may be weak) may send a small flame out through the inlet valve which has been reopened through the reversal. On the other hand, the induction of a poor mixture—usually accompanied by a pop—and the retarded combustion of such a charge, with the consequences already referred to, may, of course, occur at starting as well as at other times.

That similar effects may be produced through unintentional ignition is perhaps self-evident, and it is not only conceivable but it has been repeatedly proved that such untimely ignition may

be caused by defects in the ignition device. The popular notion that fires are often due to leaks in gasoline ducts or to poor insulation of the electric wiring can, on the other hand, in nine cases out of ten, not be substantiated.

A flame from the inlet valve ignites naturally first whatever ignitable mixture may be present in the induction pipe and in the carbureter and then attacks any combustible substance which may have been precipitated around the jet. Now, if there are corners, corridors or cavities in the carbureter where fuel can accumulate to any extent—and a surplus discharge from the jet or jets may be due to violent bumping of the vehicle or irregularity in the nozzle action—the possibility always exists that the normally harmless carbureter fires may be carried by a current of air and in the form of burning drops of gasoline to combustible substances in the drip pan.

These gathering places for precipitated fuel which therefore constitute the chief cause of fire risk are found in the majority of carbureters in which the air channel extends at right angles with the jet, but in some instances the designers of carbureters of this type have realized the danger and have taken special

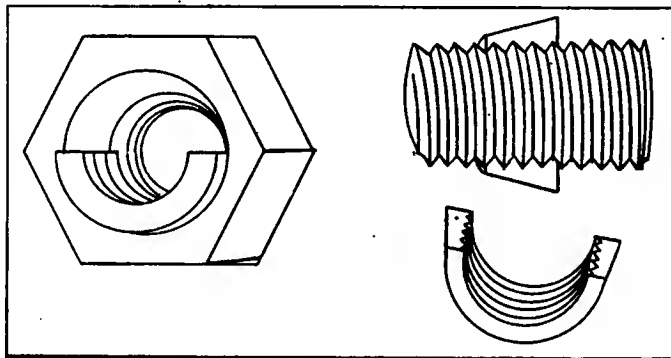

Fig. 1—Locknut for short bolt—a British improvement

measures for circumventing it. A simple expedient for the avoidance of such accumulations, and one employed especially in carbureters in which dashpots and slides are among the features of design, consists in a drain hole at the lowest place, but this provision is after all only a makeshift, for if a carbureter is inclined to stopping with the gasoline at certain motor speeds it is easily possible that a flame could ignite a drop of gasoline which was just trickling down through the drain, thus carrying a conflagration even more rapidly than usual down into the vapors and oil puddles underneath; and if this happens either a good fire extinguisher or a mass of loose sand, right at hand, is required for averting damage.

The author closes his diagnosis of the possible causes of fire leaks from the cylinders of an internal combustion engine with remarks intended to obviate any exaggerated apprehensions on the part of automobile users, while admitting that he now always carries a fire extinguisher himself when going out on a trip of some length. And, he adds, he would rejoice if designers of carbureters would take pains to remove the objectionable feature to which he refers. Manifestly his facts and arguments also bear upon the leading issues: Slide valves versus poppet valves and long stroke versus short stroke, the long stroke giving longer intervals between valve actions for a given piston speed.—From *Der Motorwagen*, Oct. 20.

**A GOOD LOCK FOR A SHORT BOLT**—Where a bolt is to be secured the locknut shown in the drawing, Fig. 1, affords, it is claimed, perfect protection against even such vibration as may loosen the customary combination of washer nut, jam nut and split pin—by shearing the pin or stripping the bolt thread—and it makes possible a shorter bolt than may ordinarily be used, resulting in a neat finish and in a minimum projection from the joined parts. The nut has a deep conical bore into which is seated a split nut the exterior surface of which is turned with a corresponding taper. It is apparently the split nut which abuts against the joined part when the main nut is fully tightened, while the small end of the split nut abuts against a shoulder in the main nut. It is said that the grip of this nut is strong even on a bolt whose thread has been partially stripped, owing to the wedging action of the conical surfaces.—From *The Commercial Motor*.

**WATER TUBE JOINTS**—A neat device for making and remaking of the flexible joints of the water circulation system, between the radiator and the motor, consists in a ring with knurled external flanges A. A. and an oblique transverse slot B as shown in Fig. 2. Two of these rings clamps are required for each joint, being fitted one to each end of the rubber tubing F, which is used for connecting the metal pipes. The ends of the rubber tube must be cut off squarely, so that the ring may be turned around on its seat with its retaining flange C rubbing against the end of the tubing. The joint is made with the aid of a length of tape D, the end of which is inserted in the slit till caught between the rubber of the tube and the interior cylindrical surface of the clamping ring. The latter is now turned around and draws

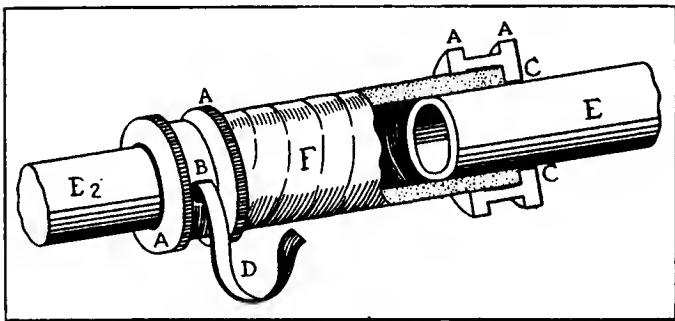

Fig. 2—Neat water tube joint—clamp at one end shown in section.

the tape with it squeezing it harder and harder against the tube the more of it is drawn in, and consequently at the same time squeezing the rubber tubing against the metal pipe E. As the circumferential pressure obtained by this method is very even, it is not necessary to screw the ring up very tight to get a joint which holds. The tape is now cut off and a slight additional twist is given the ring to remove the tape from sight. To unmake the joint, the ring is simply turned in the opposite direction, the tape always appearing through the slot, unless it has been turned in too far.—From *The Autocar*, September 23.

**FUSED SILICA FOR PLUGS AND GOGGLES**—One of the Cantor lectures organized by the Royal Society of Arts of Great Britain had for its subject: "Rock Crystal; Its Structure and Uses" and was delivered in May this year by Alfred E. H. Tutton, M. A., D. Sc., F.R.S. It dealt largely with the intensely interesting scientific and artistic applications of this substance whose field of usefulness for laboratory work, optical instruments, including spectacles and microscopes, and various practical purposes has been immensely enlarged since it became possible by means of the electric furnace and the oxy-hydrogen flame to fuse it in quantities and to produce from it articles of almost any desired form and size.

The fused quartz thus produced has been found to differ from the rock crystal of nature in many important properties. When,

for example, quartz of a specific gravity of 2.651 is fused, the solidified cooled quartz glass has only the specific gravity of 2.21, and the coefficient of expansion, though almost imperceptible beforehand from any viewpoint but the scientific one, is also reduced to the vanishing point. While rock crystal is slightly brittle and subject to fracture from mechanical violence—though not from changes of temperature—the fused quartz is so tough that an article made from it is seldom broken or chipped when dropped on the floor.

The possible use of fused quartz for spark plugs and perhaps even for the interior lining of motor cylinders or rotary internal combustion engines seems to be foreshadowed in the qualities of the substance, so that the subject gains at least a speculative interest, also from the standpoint of the automobile user and manufacturer.

An excellent and immediate test by which quartz may be told from common glass is derived from its coldness to the touch. Spectacle makers are well known to discriminate between ordinary glass lenses and the so-called "pebble" lenses made from Brazilian quartz pebbles by the cold feel of the latter when placed on the tongue. This property is ascribed to the high thermal conductivity of the quartz, which is combined with almost absolute refractoriness to electric currents, making it an excellent insulator. It is almost unbreakable, withstanding changes of temperature which would at once shatter glass, and it is far less readily attacked by acids excepting hydrofluoric, than either glass or porcelain. Its elasticity is well-nigh perfect and it can be wetted in contact with water only with the greatest difficulty; which would recommend it for driving spectacles and goggles. Quartz begins to soften at a temperature of 1,500 deg. to 1600 deg. centigrade, in the neighborhood of the melting point of platinum, and can be worked by skilled men at a temperature somewhat higher. Fused silica glass articles are now being manufactured by two British and two German firms.—From *The Journal of the Royal Society of Arts*, Oct. 27.

**SOLIDIFICATION OF GASOLINE**—In discussing means for reducing the fire risk in aeroplanes, the technical committee of the Automobile Club de France recently approved a proposition made by a military member to the effect that a competition should be organized for judging the merits of various methods for absorbing gasoline in some solid substances which will give it off in vapor or otherwise when exposed to a current of atmospheric air.

The German experiments were cited by which gasoline has been turned into a firm transparent jelly, capable of being cut into blocks and handled with tongs and other tools, by treatment with stearic acid, hydrochloric acid and caustic soda; and also the methods used, particularly in the United States, for absorbing large volumes of acetylene gas in porous solids. Finally it was recalled that the Society for Saving the Shipwrecked last year had requested the club to experiment at its laboratory with a tropical wood called Bolandero said to be capable of absorbing large quantities of gasoline, and that it had been found that this wood in reality does absorb 210 grammes of gasoline in 52 grammes of its own weight and retains it under a mechanical pressure of up to 0.219 kilograms per square centimeter of its surface, whereafter it exudes.—From *Bulletin Officiel*, September.

**THE LUBRICATING OIL CAN BE BURNED SMOKELESSLY** just as well as the gasoline, but much more air is required for this purpose than for burning the gasoline alone. The great art is to get along with as little oil as possible, so that there may be oxygen enough in a cylinderful of air for complete combustion of the gasoline charge as well as the oil. Most automobilists, when the motor acts sluggishly, by reason of over-oiling, turn on more gasoline, while they should turn on more air and reduce the oil feed.—*Automobil-Betrieb*, Oct. 15.

# Letters Answered and Discussed

## Mixture Too Rich

**EDITOR THE AUTOMOBILE:**  
 [2,908]—I have a 1191 car. When it runs slow up to 12 miles an hour it pulls fairly well, but when I open the throttle wider it starts to miss. I have examined the intake manifold for an air leak and also have had several experts try to adjust it, but they do not seem to help it any. When I stop the engine, gasoline drips from the carbureter for about a minute, then stops. Would you kindly tell me in your next issue what the trouble is and how to fix it?  
 G. W.

Albany, Wis.

Evidently your carbureter is out of adjustment and you are getting too rich a mixture; that is, there is too little air in proportion to the amount of gas in the charge which is admitted to the cylinder. It may be that the air inlet is clogged with dust or grit, or that the tension in the air valve spring B, Fig. 1, is too great. First examine the air inlet for dirt, then adjust the air valve by means of the thumb screw A. This adjustment should be made while the motor is running at a moderate speed, the screw A being turned until the best motor performance possible is obtained. After doing this try reducing the size of the spray orifice slightly by means of the adjustment provided for that purpose, as it may be that the opening is too large, causing the slight flooding which you mention.

All such carbureter adjustments should be made carefully and systematically. On

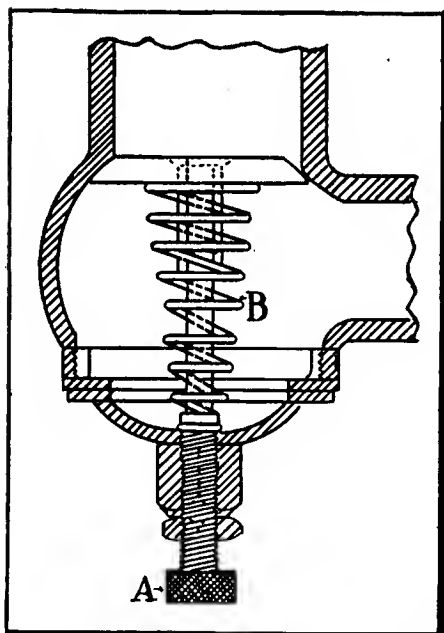

Fig. 1—Section of carbureter showing air inlet valve

*The Editor invites subscribers to communicate their automobile troubles and personal experiences, stating them clearly on one side of the paper. If the nature of the case permits, send a sketch, even if it be rough, in order to assist to a clearer understanding. Each communication will receive attention in the order of its receipt, if the writer's signature and address accompany it as an evidence of good faith. If the writer objects to the publication of his name, he may add a nom de plume.*

page 587 of our issue of October 5, 1911, will be found general directions for performing them, which may be of service to you.

## Cleaning Reflectors

**EDITOR THE AUTOMOBILE:**

[2,909]—How can I repair the reflectors of my auto searchlights? They seem to have become dull from the heat of the flame. Can I get a ready-mixed preparation and apply it myself, or must I have new reflectors? I am a constant reader of your magazine and would appreciate any information you can give.

Holstein, Ia.

A. W. SCHMIDT.

If your reflectors are not too badly smudged up you may be able to clean them with alcohol. In case this does not remove the dullness the best thing to do would be to replace them.

## Anti-Freezing Solutions

**EDITOR THE AUTOMOBILE:**

[2,910]—Will you please tell me how much calcium sulphide to use per gallon of water and will it do any harm by standing in the radiator? This is used as an anti-freezing solution.

W. B. WHITE.

Zelienople, Pa.

The use of the chemical which you mention for the purpose is not recommended. We are of the opinion that you mean calcium chloride, which makes a very good anti-freezing solution. The water in this solution, however, evaporates, and about once a month the specific gravity of the mixture should be checked up because if allowed to become too strong the calcium chloride will precipitate and clog the cooling system.

The best way to make the solution is to first make a saturated solution of the chloride, and then add water to it until the desired mixture is reached. This is done by taking half a gallon of water to eight pounds of chloride for each gallon of saturated solution required. It is a good idea to make a gallon or so extra to have on hand. You can tell if this makes a saturated solution by observing if some of the crystals remain in the bottom undissolved. If this is not the case add more crystals until some of them will not dissolve. This

solution is made applicable to the cooling system by adding to it more water, and finally, when the right proportion is obtained, a handful of lime to render it slightly alkaline. The latter is done because this solution is said to have an acidic action on the metals of the whole cooling system. As the latter has been proven, the simple precaution of adding the lime will counterbalance it.

## Fixing a Damaged Radiator

**EDITOR THE AUTOMOBILE:**

[2,911]—Apropos of the series of "Best Repair" articles you have been publishing, my experience with a damaged radiator should prove interesting to some of your readers.

A small boy threw a stone while I was

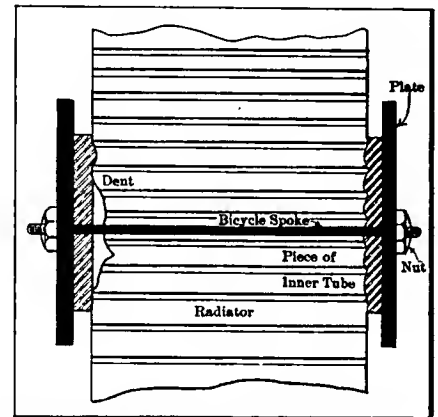

Fig. 2—Showing how a honeycomb radiator can be temporarily repaired with a bicycle spoke, piece of inner tube and a piece of metal

traveling at about 20 miles per hour and hit my honeycomb radiator. The cost was a new radiator, but that would not get me home and I had several hundred miles to travel on very important business.

The nearest village of any description was 2 miles away, and I found that there was a bicycle repairer there. I had an old inner tube in the car and proceeded as follows: I cut two pieces of rubber from the tube about twice as large as the dent and with the aid of two pieces of wood placed back and front of the radiator and some rags interposed between the rubber pads and the board I managed to bind the board together with copper wire.

Needless to say this did not hold water very long, but it served long enough to get 2 miles without losing all the water.

Fig. 2 shows the method I employed of executing a repair, which carried me to my destination without further trouble, and for several weeks afterward. I located the repairmen and had him cut a bicycle spoke

to the length indicated by me, which was sufficient to pass through the radiator. One end was already threaded and he threaded the other end. The illustration speaks for itself. Tightening up on the nuts compressed the rubber of the inner tube over the orifices of the tubes and was entirely satisfactory.

I treasure the part even to this day and I carry them on the car in case I ever have a leaky radiator tube again.

### Removing Tight Wheels

Editor THE AUTOMOBILE:

[2,912]—Will you kindly tell me through your columns the best way to remove the rear wheels of my car? I have made sev-

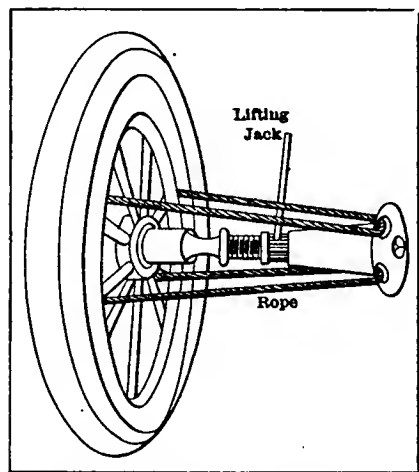

Fig. 3.—Method of removing tight wheels

eral unsuccessful attempts to get them off, but since they are keyed to the axles and I have no wheel remover it appears to be a hopeless job. Any suggestions which you can offer will be appreciated.

Buffalo, N. Y. M. E. ROWE.

Wheels may be removed by following the procedure illustrated by Fig. 3. The hub cap is first taken off and a stout rope is put around four of the spokes as near to the brake drum as possible. Then a lifting-jack is screwed down to its smallest length and placed with its head against the axle, or, as is shown in the illustration, the head is placed against a block of hard wood which touches the axle. The rope is then fastened around the base of the jack and when the latter is screwed up the wheel should come off without any difficulty.

### Cleaning Carbon Deposits

Editor THE AUTOMOBILE:

[2,913]—When the cylinders become dirty with an accumulation of carbon, grease, etc., what is the best and quickest method of cleaning it out? Can it be burnt out without damage to the engine? If so kindly tell me just how this is done.

H. T. OFFTENDINGER.

Washington, D. C.

The surest way to get rid of carbon deposit is to remove the cylinders from the crankcase and then to scrape off the accumulation with a hard, sharp-edged tool, being careful not to scratch the cylinder walls during the operation. At best, this is a rather long and tiresome job, but the improvement in the power developed and in the running of the engine afterward will compensate for the work expended.

Kerosene, or, better still, some of the so-called carbon-removing compounds, will remove the softer part of the deposit, at least. Some of these will dispose of even the harder formation also, thus cleaning the cylinder quite well. Kerosene does not generally remove the hard carbon, although if allowed to stand in the cylinder over night it becomes more effective. In using the prepared carbon removers which are on the market the directions for their use will be found accompanying them. The accumulation cannot be burned out of the cylinders.

### Making Auxiliary Air Port

Editor THE AUTOMOBILE:

[2,914]—Will you please illustrate in your columns some method for rigging up an auxiliary air port apparatus which will be adjustable from the driver's seat? A friend of mine has applied such an adjustment to his car and I have been wondering if it would be possible for me to do the same thing, as it seems to add greatly to the power of his car on hills.

Neoga, Ill. MECHANIC.

An apparatus which has been successfully used for the purpose is shown by Fig. 4. This gives a very good hand control of the extra supply of air and leads to fuel economy. The valve is placed in the intake manifold as indicated. The sketch is self-explanatory.

### Storing Cars in Barns

Editor THE AUTOMOBILE:

[2,915]—I had intended to store my car for the Winter in a country barn within which horses are kept. A friend called my attention to what he termed the fact that, owing to the proximity of horses, it would mean the ruin of the paint and varnish upon my car. He was so positive about it that I hesitated very much about carrying out my plan. Have you ever heard of such a thing? And, generally, what do you advise? It is not a question of cost, as the barn is no less than a garage, but I am sure of care and perfect protection in the one case and extremely doubtful about it in the other.

GEORGE E. HYATT.

New York City.

The varnish on an automobile is very sensitive and unless the barn in which you are contemplating storing the car for the winter is light, airy and free from dampness, we would not advise your placing the car there for such an extended period.

Coal gas and gas which sometimes percolates through heating pipes will in time cause a very bad form of spotting. Ammonia gas which is of common occurrence

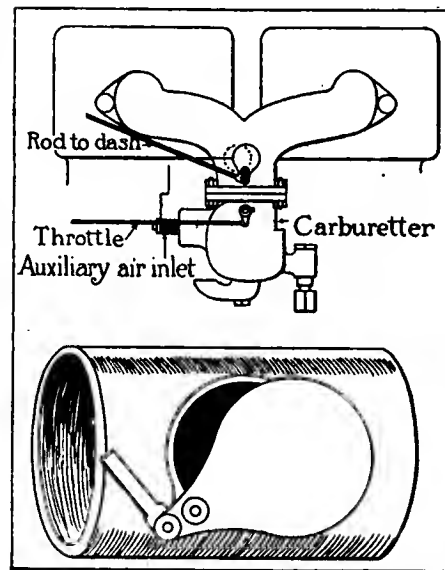

Fig. 4.—Hand control of auxiliary air valve

in stables and barns is also known to be injurious to the varnish. The form of spotting here mentioned may be recognized by the dull, lustreless spots, showing a film of greasiness which afflicts the surface. Damp and ill-ventilated garages are the cause of a great deal of this spotting, which is very difficult to remove. Pure, fresh air brought into the storage quarters of the automobile in a sufficient quantity to counteract the accumulated foul air, fetid odors and gases, will, however, generally prevent spotting and loss of luster.

In storing automobiles in places such as you mention, it is therefore advisable to have the quarters well ventilated and lighted; also to cover the cars with suitable cloth covers, thus preventing a great deal of dust and dampness from reaching them. In general it might be added that the average barn is not suitable for the storage of a valuable automobile.

### Regarding Acetone

Editor THE AUTOMOBILE:

[2,916]—Can you offer me through your columns information concerning the composition and nature of acetone, and is its use and manufacture controlled exclusively by patent rights?

J. W. TAYLOR.

Atlantic City, N. J.

Acetone is a well-known volatile, liquid chemical compound with the formula  $CH_3COCH_3$ . It is usually obtained by the distillation of certain acetates, such as starch, gum or sugar, and is used to dissolve many organic compounds. The use and manufacture of acetone except in connection with certain manufacturing appliances used by acetylene gas makers are not controlled by patent.



# Little Bits of Motor Wisdom

## Pertinent Pointers of Interest to Repairman and Driver

**T**OOLS FOR TESTING WORK—Few tools in the shop are of more use than try-squares and the various forms of spring calipers. Calipers are employed where the accuracy of the measurement will not permit of the use of ordinary steel scales or rules. Micrometer calipers and standard or limit gauges must of necessity be applied in cases requiring extreme fineness of measurement, often being used to get results as close as .001 inch or less. A delicate touch and good judgment are essential to skilful manipulation of all forms of calipers.

Fig. 1 illustrates the various types of these tools and their application to the work. At A are shown what are called keyhole calipers, these being used to measure from the side of a hole to the edge of the work; inside calipers are represented at D; outside calipers at C, and at B are seen a pair of spring dividers. Keyhole calipers are also of use in measuring the throw of a cam, the thickness of the shell of a tube, or in determining whether or not the hole in the work is central. The manner of using the other forms is obvious. In using spring dividers, after locating the center, incline them slightly in the direction of revolution and describe the circle. Be sure that the surfaces to be measured are perfectly clean before applying the calipers. This is especially important with the finer measurements. In making very large circles, for spacing and the like, extension dividers or trammels are used. For all ordinary work in the repair shop measurements can be made with a steel scale. These are accurate, and when skillfully used are second only to micrometer and vernier calipers.

Try-squares have several very well

known uses, among them being to test for squareness of stock such as B in Fig. 4. In this connection it might be mentioned that D is the try-square proper and C the "beam." When testing for the flatness of surfaces, hold the try-square and the block B up to the light and tip the blade toward you so as to form a line contact between the two surfaces. If no light shows along the blade of the square, the surface is true. A bevel-edged square is sometimes used to get this line contact for fine work. This is shown at D, Fig. 2. To make sure that a surface is absolutely plane it should be tested both along its length and width and diagonally.

**BOLTS REQUIRE ATTENTION.**—It is frequently the case that after traveling over cobblestones or other rough roads nuts will jar loose even if fastened by means of a lock nut. A split pin or castellated nut should always be used if the position allows of this practice. In placing a nut upon any part of the motor with a long wrench or spanner it must always be remembered that some day it will have to be removed. With a long leverage immense turning force can be applied to a nut, but it is not necessary to exert the fullest strength of which a man is capable in placing a spark plug in a cylinder or tightening a hub cap nut.

Rust is often a factor in preventing the removal of nuts which have been subjected to moisture. In this case the application of a little heat, either from a gasoline torch or from some gasoline which has been soaked up in a piece of cotton waste and wound about the joint, will aid the refractory member. Prevention in any

case is better than cure, and if the thread is coated with graphite before tightening it will always be easily removable and will never give any trouble in the direction of rust.

The wise automobilist will generally carry one or two bolts and nuts of the size most used in his motor, if he be going on any extended trip where garages will not always be in reach and there is a likelihood of repairs having to be made upon the road.

**OVERLOADING THE CAR.**—It is evident that the average passenger automobile, which is designed primarily as a vehicle of pleasure, should not be overloaded. A five-passenger touring car of medium weight is perfectly capable of taking care of all the baggage a party of five need take on a trip of ordinary length. But when this limit is stretched and the car on its way

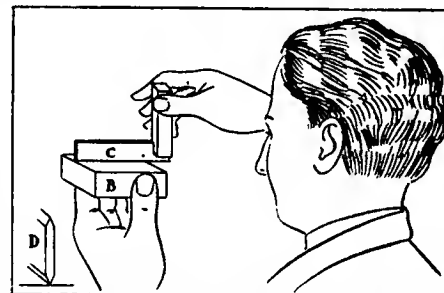

Fig. 2—Testing the flatness of a surface plate with a try-square

through the country has the appearance of the old-fashioned ship of the desert it cannot be reasonably expected to perform its work with any degree of comfort to the passengers. The springs and suspension of the car are designed for a given load, and a certain percentage is allowed as a factor of safety and to take care of any reasonable amount of overload. But a very uncomfortable vehicle can be made of the best of cars by overloading to such a degree that the shocks which are given by the irregularities of the road surface are transmitted directly to the occupants of the car.

In loading the car compactness must also be made an object, not alone for convenience of the occupants, but to insure the easy riding qualities of the car itself. It is therefore advisable for the occupants of a car when starting on a tour to remember that it is of great importance to carry as little as possible, and to carry that little compactly.

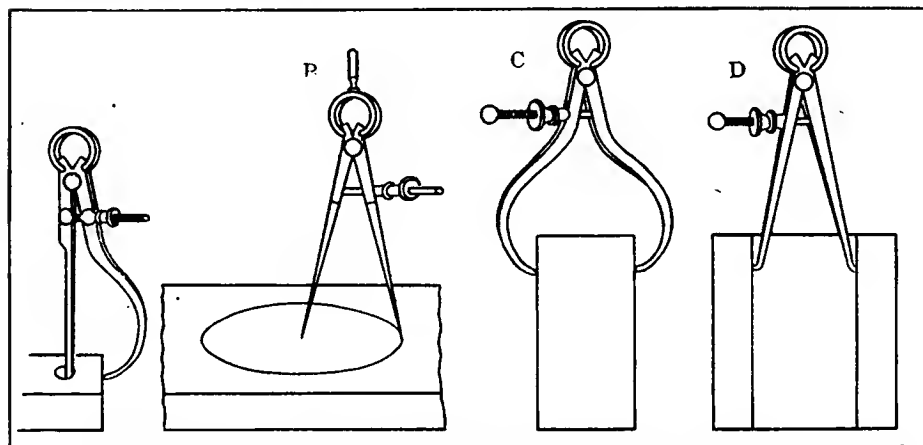

Fig. 1—Illustrating the different types of calipers and their typical uses in making accurate and necessary measurements

**HAMMERS FOR SPECIAL WORK.**—The ordinary flat-headed variety of hammer cannot be used for the various pieces of work which will arise and for which a special hammer must be called into requisition. Peening operations will require hammers of different shapes, depending upon the requirements of the particular case in point. As shown in Fig. 3, the heads of the hammers will be formed so that when it is desired to indent the metal or bend it to a certain form the work may be much shortened by the use of the correct hammer head.

The ball peen as may be seen by its shape is not so much for lumping the material as it is for spreading it and hence thinning it out in the vicinity of the point at which the

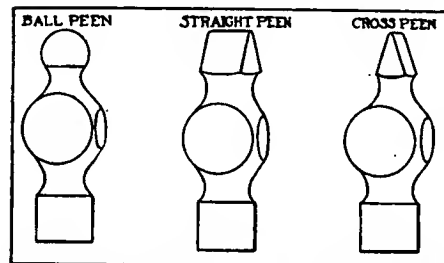

Fig. 3—Three different shapes of peening hammer heads

blows are directed. The cross peen and straight peen heads may be used interchangeably as the difference between them lies in the fact that the lines of direction of the heads are at right angles to each other. They are designed for the purpose of beating the metal into varying thicknesses or in some cases for spreading it about a given point.

**TEMPERATURE OF COOLING WATER.**—The temperature of the cooling water will vary under different conditions under which the car is running. In mounting a hill with throttle open and retarded spark the charge will be much more slowly burned and the cylinder will have far less chance to be cooled between explosions. This will result in heated cylinder walls and hence in much warmer water. It is not an uncommon thing to have a steaming radiator after climbing a long steep hill on high gear.

In running along a level road the temperature of the cooling water ought not range much above 180 degrees Fahrenheit, so that when it is necessary to negotiate rough or hilly country there will be a sufficient margin before reaching boiling point to allow for any of the changes in temperature which take place. In Summer there will also be a marked tendency for the cooling water to become overheated on account of the air which is drawn over the radiator being so warm that it has very little cooling influence. In Winter the problem is entirely different and becomes one of keeping the water warm enough. In many cases the motion of the car is sufficient to cool the radiator sufficiently for all purposes and the fan belt can then be de-

tached so that it is not in use. A nicer way would be to have a fan which has a variable pitch, so that it may be regulated to suit the requirements of the temperature of the locality and season.

It is not desired to cool the motor to a very great extent, as every unit of heat which is thrown into the cooling water represents a loss of power. Every gallon of cooling water which is raised 10 degrees in temperature in a minute represents the loss of approximately 2 horsepower. This seems like a very large quantity when it is considered how often the temperature of the cooling water rises and falls, and it is a large quantity, for fully one-third of the horsepower which is contained in the fuel supplied to the engine is lost in cooling the motor. It is therefore evident that it is a serious loss when too much of this heat is thrown away by having the cooling water at a higher temperature than is necessary.

**USING CHIPPING HAMMERS.**—Every repair man and driver is familiar with the various types of chipping hammers. Nevertheless a few hints as to their use may not be amiss. Simple as the operation may seem, there is quite a knack in getting the most out of the hammer blow. The handle should always be grasped firmly near its end, so that the blow can be controlled, and the arm should be swung from the elbow. The chipping of metals is most commonly done when they are dry. Start with short, light strokes and increase to long and vigorous ones as the work progresses. When chipping out key-ways, grooves or slots, the chisel will cut better if wiped off occasionally with a piece of waste saturated with oil. When chipping a surface always fasten the piece in the vise horizontally, if possible, and use a packing block to prevent slipping. Begin the cut by holding the chisel parallel to the surface of the work and take off the first chip with a sharp blow. For succeeding cuts the chisel should be inclined somewhat. The manner in which the chips come off affords a means of determining the kind of metal that is being worked. If the material is hard cast iron the chips will fly off, while if steel or wrought iron they will curl up in front of the chisel. Chipping is rather a makeshift operation at best and should be resorted to only when no machine tool is at hand.

**LONG BEARING A GOOD FEATURE.**—It is a serious fault to have bearings in a machine or any length of shafting of insufficient area to amply support the weight and other live strains which the shaft will be called upon to support. With the great tendency to save weight in the motor by various means the length of the various bearings should be well considered, and an intending purchaser should be careful in this respect, for it is of vital importance. There are certain rules for the dimensions and spacing of bearings which cannot be neglected, so that when the cylinders of an engine are cast

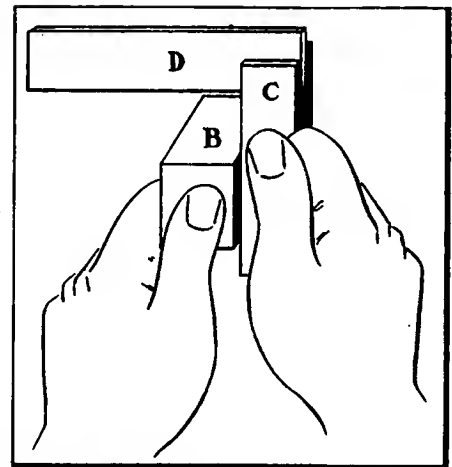

Fig. 4—Testing stock for squareness before using it in machine

in pairs the length of the bearings between the two blocks of cylinders must be sufficient to compensate for the greater length of shafting between bearings, or, what amounts to the same thing, the fewer bearings for the same length of shaft.

A shaft with a long interval between bearings will have a decided tendency to whip. By this is meant that the shaft will tend to form a loop in the same manner as when a string with a weight at the center is twirled about the two points of support at its ends. When this motion commences, it will gradually increase and result will be serious wear on the end of the bushings. Long bearings will go far in preventing this evil, but they are without the desired effect if they are not backed up by a shaft sufficiently thick to withstand bending stresses.

A shaft is classed in mechanics as a simple beam, and the calculations involved in determining the proper thickness of the shaft and the length of the bearings are amply summed up in formulæ which take into consideration the horsepower transmitted and the distance between supports. The maximum explosive force of the gas in the cylinder is taken as the working stress and a considerable factor of safety is allowed on account of the severe stresses to which the shaft may be submitted.

In a well-balanced motor the stresses on the crankshaft are so well distributed that the whipping tendency is reduced to a marked degree. This balance will go a long way toward eliminating the vibrations of the engine and will produce a smooth-running engine instead of a machine which rocks and tosses under unbalanced forces. The balance of the engine is maintained often by distributing the weight in the fly-wheel or in putting counter-weights upon the crankshaft so that all the large forces which are not directly connected with driving the motor are met by equal forces, which are caused by the revolution or reciprocation of these parts. Other and more complex methods of engine balance involve the changing of the connecting-rod angles. The efforts spent upon balancing the engine are well repaid, and make the engine no more costly to manufacture.

# My Ideal 1912 Automobile

## Readers' Conceptions of What Next Year's Car Should Be

### Reasonable \$1,000 Ideal

EDITOR THE AUTOMOBILE:

I have read with much interest the letters you have been publishing describing the ideal cars of some of your subscribers and note that most of them run to large and expensive machines. Last year I drove a six-cylinder 40-horsepower touring car and a very light runabout. This year I am still driving the six, but exchanged the runabout for another popular-priced light runabout and cannot speak too highly of the faithful service, in all sorts of weather, that these little fellows have rendered, the one I have having averaged 1000 miles a month since March and having had but the slightest care. A considerable part of the distance has been cross-country work.

Based on experience with these three cars, I believe in a light, low-priced car if honestly built. It should have a 3¼-inch by 4½-inch six-cylinder, four-bearing engine developing about 30 horse-power. The engine and transmission should be a unit, with the cylinders cast together as in the Ford L-type heads with enclosed valves. The crankcase should have large hand holes with readily detachable covers. The thermo-syphon system of cooling should be used with a fan-bladed flywheel on the front of the engine, and a high-tension magneto with fixed advance and no batteries. The oiling should be by splash in the crankcase, the level being maintained by filling from time to time. A hand throttle on the steering wheel with foot accelerator works excellently. The clutch should be of multiple-disc type in an oil bath. There should be three speeds forward and reverse, sliding gear transmission with the control in the center of the car, one pedal to operate the clutch and service brake on the propeller shaft and another pedal to operate the emergency brake on the rear wheels with ratchet to lock same in position. The wheelbase should be 110 or 112 inches, with four full-elliptic springs, axles well braced and 34 x 3½ clincher tires.

The body should be of the straight type with relatively low seats, and a knapsack type of gasoline tank back of the rear ones. I have used both right- and left-side drive and have no preference. The rear wheels should fit on the rear axle on a taper with lock nut and key. Steering knuckles, yokes and connections should be of ample strength—they look very frail on most light cars. All shackles, spring joints, knuckles and the like should be fitted with little spring-covered oil cups.

All moving parts and accessories, such as oilers, pumps, fans, sight feeds, self-starters, complicated electrical work and the like, should be made as few as possible. Such a car as I have outlined should be flexible, light, with more speed and power than necessary, simple to operate and to keep in tune, and, if honestly built, should last a long time and give extensive service.

Based on the selling price of the host of little cars that are coming into the market, I should think "my car" could be sold for \$1,000 or a little over. NOVICE.

Mineola, L. I.

### Another Youngster's Idea

EDITOR THE AUTOMOBILE:

The following is a general outline of my ideal 1912 car: The engine should have four cylinders of the L type, cast singly, with copper jackets. The motor should have a bore of 5 inches and the stroke should be 8 inches with 2¼-inch valves. These valves should be enclosed so as to exclude grit. This construction will give full 40 horsepower according to the A. L. A. M. rating and on a brake test will develop about 75 horsepower.

There should be a five-bearing crankshaft and camshaft, the bearings being of bronze or babbitt metal. Lubrication should be by positive force feed, the oil being contained in a tank at the side of the motor with a sight feed on the dash. The ignition should be by two independent Remy magnetos with two sets of Bosch plugs over the valves. The cooling system should consist of a honeycomb radiator with a gear-driven fan and a water pump.

Selective type of transmission should be used with four forward speeds and reverse, with direct drive on third speed, and geared 2 to 1 on direct. The clutch should be of the cone type, fitted with cork inserts. The car should be shaft driven and should have a Timken-Detroit rear axle, roller bearings being used with it. The front axle should be of the B. & L. castor type.

The exhaust should have two complete systems of outlet, consisting of a muffler fitted with a cutout and open exhaust pipes coming through the hood. The wheels should be similar to those which Ray Harroun used in the 500-mile race and should be 40 inches in diameter, shod with 6-inch tires front and rear. There should be four large brakes on the rear wheels, two internal and two external. The wheelbase should be about 140 inches and the car should be equipped with semi-elliptic

springs front and rear, and should also have Hartford shock absorbers. Steering should be of the worm and sector type, with a 20-inch wheel, hard rubber and corrugated.

The body should seat two people, seats being on the floor, with 10-inch cushions and high backs, similar to those used on the Mercer raceabout. A 50-gallon gas tank should be mounted back of the seats. I would desire a combination Klaxon horn, engine-driven tire pump, Gray & Davis dynamo, full set of Gray & Davis torpedo electric lamps and a Warner autometer. An extra tire and rim complete should be mounted in the rear of the gas tank.

The car should be built of the very best materials. Such a car as I have outlined would cost about \$5,500.

OLIN M. VAN NEST.

German Valley, N. J.

### Specifies Full Electric Outfit

EDITOR THE AUTOMOBILE:

My conception of the ideal locomotive is as here given.

The motor should have four cylinders, probably cast singly with a unit construction including motor, gearset and clutch. The suspension should be three-point and the cylinders of the T-head type. The valves should be enclosed. The motor should have a bore of 4 1-2 inches and a stroke of 5 1-2 inches. The cooling water should pass through a honeycomb radiator.

The power should be transmitted to the gearset by means of a leather-faced cone clutch equipped with spring plungers for easy engagement. The gearset should be of the four-speed and reverse type with direct drive on third; the shafts should run on ball bearings.

The propeller shaft should not be less than 14 inches in diameter and should transmit its power to a driving axle of the same diameter. The rear axle should be braced by means of special tension and distance rods.

The frame should not measure less than 3 x 5 inches at the midship section, and there should be as near as possible one-third of the frame between the front end of the rear spring and the rear end of the front spring.

Among the accessories I would have an electric generator for lighting as well as ignition, and an electric self-starter. The dash outfit should include a gasoline gauge.

The price of this car should be \$2,500.

Kingston, N. Y.

EXPERIENCE.

## Sizing Up the Used-Car Situation

**T**HERE are few lines of business that the automobile public in general knows less about—but thinks it knows more about—than the second-hand car trade. The reason therefor is that every motorist, comparatively speaking, has at some time or other had an opportunity to either buy or sell a used car, or to at least witness or hear about such a transaction. A single experience of this kind will usually enable a man to form a decided opinion about the situation. But let it be said that this throws a sad light on the reasoning power of a man thinking in this fashion, for there is no more complex situation than the problem offered by the vast number of used cars that are waiting to be disposed of, nor are there many lines of trade in which a thorough acquaintance with the conditions that obtain is so indispensable as in the second-hand car business.

It cannot be denied that this trade, if it is to be done profitably, must to a certain extent be regulated by a system. But, strange enough, the system used in this line of endeavor, however important, is an invisible one; that is, while it exists without a doubt, and while the business is carried out according to well-regulated principles, there is practically no time or work expended on any kind of filing system specially adapted to the requirements of the situation. Instead of this the ability of the men handling the work in every detail is principally relied upon in order to make the best possible out of the problem facing the dealer.

The second-hand car business has been repeatedly denounced of late by makers and agents; it has been called a nuisance and worse, and there have come about a dozen proposed solutions from various men prominent in the industry. But, considering the situation coolly and without bias, the observer will be impressed by the fact that as long as the vast production of yearly models of automobiles is continued the types out of date but still alive will have to be disposed of if their present owners are to be persuaded to buy new, and, in a good many cases, better and costlier cars. Nor is there any use in decrying any particular phase of the second-hand trade as it is now conducted, or to advocate any Utopian solutions of this problem. Here, as in so many other fields, the wisest course is rather to bear the ills we know than fly to others we wot not of.

The used car trade is handled in different styles by different men. There is hardly a firm in the metropolis which does not trade in used cars of its own make as long as these automobiles are in a salable state. In many cases this is regarded as necessary, for otherwise the prospective purchaser may buy another make of car from an agent who is more accommodating. Of course there are some makes on which such a transaction is impossible because of their low prices, but this very fact makes it improbable that a purchaser will demand his old low-priced car to be taken in and stand pat on his proposition after its unreasonableness has been explained to him.

One way of meeting the second-hand car problem consists in disposing of the used car without either a chance of winning or losing on the bargain. This idea is carried out by a number of responsible New York firms. If a prospective has become interested in the make of automobile handled by the dealer in question the salesman in charge of the transaction naturally endeavors to close the sale. In a good many cases an old car stands in the way of the new one to be bought and the following arrangement is then resorted to: The purchaser pays the vendor the full price of the new automobile, with no deduction for the value of the old car the buyer wants to dispose of. The company selling the new machine agrees, however, to do all it can to sell the used automobile for its owner, with no profit what-

ever accruing to the agent. In some cases the salesman doing the business may even suffer a loss because it is up to him to sell the old car for its owner; but if he should find no time to do so, and another man closes the deal in his place, he will be obliged to pay that man a commission out of his own profit on the new car sold.

Other automobile agents, when selling a new car, take in an old machine and its value is deducted from the bill made out to the customer. It stands to reason that before trading in such an automobile the agent has his experts look over the used car and value it at what it is worth. The experts in the case are men who have been specialists in the second-hand car business for many years and who know just how much it will cost to put a car in a salable state and to sell it. The value placed upon it by the expert is deducted from the bill and there is no bargaining done. After the deal has been closed the car is repaired, if this is necessary, and then sold for the price that was allowed for it to its former owner. Few firms attempt to profit on an automobile thus acquired.

The state of affairs is different, however, when used cars are handled by dealers who trade in none but used cars. Evidently these men must be still more careful in their transactions in order to do a profitable business. In their line of trade, one would imagine, the use of a suitable system must be still more indispensable than in the case of an automobile agent who handles second-hand machines but occasionally. The truth is that the true second-hand car man uses the least amount of book-keeping of all automobile dealers. Card files, in which a special card is devoted to each car bought, and on which the details of its repair are entered afterward, are seldom used. The shrewd second-hand car man has all his system in his hand. It is a flexible system at that, thus being of the most practical kind, and its essence is: Buy as cheap as possible and sell as quick as possible for as much as you can possibly get.

If the situation, as reflected by the action of the various dealers, is surveyed, one can hardly help agreeing that the second-hand car problem is met, in practice, in the most advantageous manner possible. The majority of car owners seeking to dispose of a used car will always first try to sell the car themselves. If this scheme does not work, then it is attempted to trade in the car when buying a new one. If the owner succeeds, all the better. If, however, he does not desire to buy another machine, or if the agent makes him understand that he cannot accept the car as part payment owing to there being but little chance of his selling the machine, the owner will surely hie him to the second-hand car man's den and patiently submit to what cannot be avoided.

But the average owner distrusts every used car except the one that he has to sell. This is one more case where a man fails to see the beam in his own eye, but is very keen in noting the mote in that of his brother. This, however, influences business but little. It goes on, and the man who fails to understand the conditions and to take them into account is invariably the loser in the deal. The conditions are simply these:

A used car never looks as good as a new one; hence the desire of a man to exchange his machine for the latest model. The average owner cannot afford to throw away a good car after a year or two, hence the necessity for its being floated into the second-hand market. The production of automobiles and the demand for new ones grows steadily; at the same time a vast number of used cars have to be sold, often for a price that would buy a pretty good new car which people prefer; hence the difficulty an owner experiences in selling his used car.

## Among the New Books

**MONOPLANES AND BIPLANES**, by Grover Cleveland Loening, B. Sc., A. M. Published by Munn & Company, of New York. 340 duodecimo pages with 278 illustrations. Price, \$2.50.

THIS work on the most up-to-date subject for scientific as well as unscientific curiosity, contains a great deal of industriously collected information about the mechanical details of aeroplanes, containing descriptions and illustrations of practically all the varieties which have flown and have come under public notice. The information seems to be reliable where the work involved on the author's part is only that of the conscientious compiler. The theories which were currently accepted among aeronautic students for many years before any "heavier-than-air" machines flew, are also rendered with fidelity, and these may be of value to the reader, in so far as they serve to suggest what a large number of questions remain to be investigated experimentally before any scientific basis for orderly reasoning may be said to have been created for the guidance of either constructors or students. The inquiring reader who is satisfied to trust his intuitive perceptions will, however, find the mere mention of the various theories helpful, even if he cannot subscribe to their correctness, and herein lies probably the main value of all the books on aviation so far published. Mr. Loening's book is in this respect no exception and may perhaps be considered as especially stimulating because the author's diction and reasoning combine to rouse the reader's critical faculties. Phrases such as "data is," "enabling the lines of future development to be pointed out," "one of the greatest detriments" or "the fact that aviation is reasonably safe can unquestionably be concluded therefrom"—all plucked from the author's brief preface—can scarcely be considered as reassuring when one is looking for the earmarks of that schooled mentality whose guidance on a difficult subject should be readily accepted as of presumptive value. When we read on page 21: "That air as a medium is similar in character to water is shown conclusively by the accompanying photographic results of the experiments on stream lines of air by Marey," some doubt is aroused as to the stringency of other conclusions accepted as scientific by the author. Something more than photographs would be required to prove that air, highly elastic and compressible, is comparable in any important relations bearing upon the subject of aviation to unelastic and incompressible water; molecular mobility being about the only property which the two mediums have in common, and that in very unequal degree. Chapter V begins with this sentence: "It is well known, from the investigations of Froude and others, that the frictional resistance of a body in water was great." And this is followed by: "By analogy it would seem as if the friction of the air would also be considerable." In the face of such logic so expressed, the discriminating reader loses heart, and not even the statement that the book was contrived with assistance from members of the faculties at the Columbia University suffices for upholding the respect which its scientific verbiage would seem to claim.

An example of glib reasoning is presented on pages 19 and 20. Here we read: "In the Summer, on a dry clear day, the high temperature causes a low density"—of the atmosphere—"and the pressure is light, so that the aeroplane experiences the least resistance, and therefore at this season travels at a higher speed." It is difficult to know, of course, what an "aeroplane experiences"—to use the author's strange anthropomorphic phrase—but the careful reader of this book of instruction may safely deny the validity of the "therefore." The action of the propeller on the rarefied air as well as the sustentation such air affords are decidedly matters to be looked into before it may be asserted that the aeroplane "therefore" travels at a higher speed in thin air. And on the same page 20 a superfluous diagram sorely maligns Sir Isaac Newton's memory in ascribing to him a preposterous notion of the manner in which a horizontal stream of air acts against a vertical plane.

The author's license to teach a science which does not yet

exist and a practice which has not yet become so crystallized that information for to-day holds good to-morrow, seems to have been issued on a purely commercial basis, for which it is perhaps a valid excuse, however, that those of really scientific attainments generally refuse to write anything on the subject which the public would be willing to read.

**WELDING THEORY, PRACTICE, APPARATUS AND TESTS; ELECTRIC, THERMIT AND HOT-FLAME PROCESSES.** By Richard N. Hart, B. S. 181 pages with 93 text illustrations. Published by McGraw-Hill Book Company, New York. Price, \$2.50.

The subject of this work is theoretically in a chaotic state while in practice the arts of soldering and welding are progressing from week to week with tremendous strides. Few are in a position to keep step with the developments, and as these are intimately connected with other forms of advancement in metallurgical insight and throw highly interesting sidelights on the properties of metals, their alloys and their impurities, the technically interested public have reason to thank Mr. Hart for his courage and resolution in seizing this subject in its flight, snatching it, one might say, from out of the workshops, the testing stations and the pages of periodicals and fixing it, in so far as it will consent to be fixed, in the pages of one short volume. Nobody concerned with the joining of metals or metal parts can help receiving valuable information or hints from its pages, and even those familiar with the general conditions for the malleability and the "flow" of pure metals and alloys, with the phenomena of "solid solution," the formation, destruction and reformation of metallic crystals under the influence of heat and hammering, and with the molecular transfusion which takes place between metallic substances in many instances if only intimate contact is effected under moderate heat, will not fail to find among the facts related by the author many which will broaden or deepen their understanding for all kinds of metal work. Still the information offered is essentially practical.

In this useful work some curious lapses are nevertheless observed, as where the cohesion between two perfectly plane and smooth glass plates (in reality due to atmospheric pressure) is compared to the partial weld which may be produced between two plates of iron highly polished and heated to a dark red, or where it is stated that "the ancient Greeks knew of it (silver) as the metal electrum, an alloy of gold and silver," as if the almost pure silver of many ancient coins had been unknown to them. Such easily avoidable flaws bear witness of haste, but on the other hand the terseness of the author's diction, marred only in a few places by grammatical incongruities or clouded sense, conveys a refreshing impression of a well-filled mind capable of checking off the second-hand information which is necessarily included by comparison with a good store of data verified through personal and practical experience. On the foundation supplied in this work it should be possible in a few years to produce a thoroughly systematized textbook and shop guide on the arts of soldering, brazing, welding and fusing—now blending into one—and upon the closely related methods for cutting metal by local fusion.

**MECHANICS FOR ENGINEERS.** By Arthur Morley, M.Sc. Published by Longmans, Green & Co., New York. 282 pages, 200 illustrations. Cloth, \$1.20.

In this work the principles of mechanics are brought to the student in a clear, concise manner which will prove valuable to those who are studying the subject without the aid of an instructor. The work is amply illustrated by diagrams which bring out the points involved in a manner which renders them easily understood by the students of elementary mechanics as applied to engineering.

Kinematics, the study of bodies in motion, and statics, the study of bodies at rest, are taken up in the first part of the book, while the remainder is devoted to the laws of inertia and gravity, the moment of inertia and the elements of graphic statics. Relative examples and their solutions are given as well as examples for solution by the reader.



## Harking Back a Decade

ITEMS appearing in *The Motor Review* of November 14, 1901:

An injunction has been issued by the United States Circuit Court in New York, restraining Frederick R. Wood & Son, makers of electric vehicles, from the use of the two-motor drive construction patented by the Electric Vehicle Company.

The Milwaukee Automobile Club has been planned and as soon as it is formed it will affiliate with the Automobile Club of America. Tours, social and sporting events will be arranged.

The recent tests in handling mail at Syracuse showed that the automobile could effect a saving of 66 per cent. in the time involved in collecting.

Actual sales at the Madison Square Garden show just closed totaled close to the \$1,000,000 mark. The demonstration track around the exhibits was abandoned this year, but most of the exhibitors had demonstrating cars outside the building to give street rides to those who really meant business. The attendance was very steady throughout the show but at no time approached what would be considered a crowd.

The Franklin company, which has been experimenting with a four-cylinder, air-cooled motor, which drives direct to the rear axle in high gear and with two forward speeds and reverse, is about to market its experiment. Four pedals control the brake, reverse, high and low speeds. The car has 28-inch wheels and weighs 850 pounds. It is rated at 7 horsepower.

The Diamond Rubber Company, of Akron, O., is erecting an addition to its plant that will increase its floor space to 500,000 square feet. The factory is one of the largest of the kind in the United States.

The Winton Motor Carriage Company will establish branch houses in Philadelphia, Boston and Chicago as the result of its increased capitalization. This move will be made next Spring.

The automobiles shown at Madison Square Garden one year ago were as a class shaftless carriages, a combination of the regular American carriage and a motor. The vehicles shown this year are very largely of the French type, which, to all appearances is rapidly winning favor with American owners, not as a foreign fad but on its technical merits and the appropriate-

ness of the design to the required service as a pleasure locomotive.—Editorial.

The automobile world here is now goaded anigh to the revolutionizing point, and something must be done. The worst of it is that there no sort of appeal against the sentences of these bundles of crassly and conservatively prejudiced old women, and though the Lord Chancellor is believed to possess some power over them, I can recall no publicly known incident in which that power has been put into force.—London correspondence on conviction of automobilists for alleged speeding.

Fifty cars of the new model Stevens-Duryea car are under construction at the Chicopee Falls factory. Three of the test cars have been in use since last Summer with satisfactory results. The car has a two-cylinder motor, rated at 5-horsepower and is equipped with wire wheels.

W. J. Stewart, of Newark, N. J., driving a Locomobile, claims the long-distance speed record on a hill as the result of his climb of Eagle Rock near Orange. This hill averages 18 per cent. grade. Mr. Stewart's car made the climb in 2:43. The length of the hill is not given.

Eleven manufacturers of automobiles and eight accessory houses have already made application for blocks of space exceeding 1,000 square feet each at the Chicago Automobile Show, which will be held in the Coliseum March 1-8. All the available space has been snapped up and indications point to a show of far greater magnitude than the one of last season.

## English "Driver" Ousts French "Chauffeur"

French motorists are up in arms owing to the fact that an English word has slipped into the French vocabulary and is becoming quite popular. Reference is made to the word "driver," which, to a degree, has supplanted the word "chauffeur." But it is a question whether those who have adopted it will abandon it. The same sort of protest was heard when the proposition was first made to change the road right-of-way from right to left, the latter being the English system. But the French people managed to survive the shock and "driver" will doubtless replace "chauffeur."

# Calendar of Coming Events

### Shows

Nov. 20-25.....	Indianapolis, Ind., Fall Show, Indianapolis Automobile Trade Association.
Dec. 30-Jan. 6.....	Buffalo, N. Y., Annual Show, Seventy-fourth Regiment Armory, Buffalo Automobile Trade Association.
Jan. 2-11.....	New York City, Hotel Astor, Importers' Salon.
Jan. 6-13.....	New York City, Madison Square Garden, Twelfth Annual Show, Pleasure Car Division, Automobile Board of Trade.
Jan. 6-20.....	New York City, Madison Square Garden, Annual Show, Motor and Accessory Manufacturers.
Jan. 10-17.....	New York City, Grand Central Palace, Twelfth Annual Show, National Association of Automobile Manufacturers; also Motor and Accessory Manufacturers.
Jan. 13-27.....	Philadelphia, Annual Show, First and Third Regiment Armories, Philadelphia Automobile Trade Association.
Jan. 15-20.....	New York City, Madison Square Garden, Twelfth Annual Show, Commercial Division, Automobile Board of Trade.
Jan. 13-19.....	Milwaukee, Wis., Auditorium, Fourth Annual Show, Milwaukee Automobile Dealers' Association.
Jan. 22-27.....	Detroit, Mich., Wayne Gardens, Eleventh Annual Show, Detroit Automobile Dealers' Association.
Jan. 22-27.....	Providence, R. I., Providence State Armory, Rhode Island Licensed Automobile Dealers' Association, Automobile and Accessories Show.
Jan. 27-Feb. 10....	Chicago Coliseum, Eleventh Annual Automobile Show under the auspices of the National Association of Automobile Manufacturers. Pleasure cars, first week. Commercial vehicles, second week.
Jan. 29-Feb. 3.....	Scranton, Pa., 13th Regiment Armory, Second Annual Show.
Feb. 3-10.....	Montreal, Canada, National Show, Drill Hall, Automobile Club of Canada.
Feb. 5-17.....	St. Louis, Mo., Coliseum, Annual Show, Pleasure cars, first week. Commercial vehicles, second week.
Feb. 12-17.....	Kansas City, Mo., Annual Show, Combined Association of Motor Car Dealers.
Feb. 14-17.....	Grand Rapids, Mich., Third Annual Show.

Feb. 17-24.....	Newark, N. J., Fifth Annual Automobile Show, New Jersey Automobile Exhibition Company, First Regiment Armory.
Feb. 17-24.....	Minneapolis, Minn., National Guard Armory and Coliseum, Annual Automobile Show, Minneapolis Automobile Show Association.
Feb. 17-24.....	Pittsburg, Pa., Second Annual Show, Exposition Bldg., Pittsburg Auto Show Association, Inc.
Feb. 19-24.....	Omaha, Neb., Seventh Annual Show, Auditorium, Omaha Automobile Show Association.
Feb. 19-24.....	Hartford, Conn., Annual Show, Automobile Club of Hartford, State Armory.
Feb. 20-24.....	Binghamton, N. Y., State Armory, Third Annual Show, Automobile Dealers' Association.
Week Feb. 22.....	Cincinnati, O., Annual Show, Cincinnati Automobile Dealers' Association.
Feb. 26-Mar. 2.....	Elmira, N. Y., Second Annual Show, Elmira Automobile Club.
March 2-9.....	Boston, Mass., Tenth Annual Show, Boston Automobile Dealers' Association, Inc.
March 4-9.....	Denver, Col., Auditorium, Annual Show.

### Meetings, Etc.

Nov. 20-24.....	Richmond, Va., First American Road Congress, under auspices of American Association for Highway Improvement.
Nov. 22.....	Road Users' Day, under direction of Touring Club of America.
Dec. 20.....	New York City, Waldorf-Astoria, Annual Banquet of the Automobile Club of America.
Jan. 18-20.....	New York City, Annual Meeting of the Society of Automobile Engineers.
<b>Race Meets, Hill-Climbs, Etc.</b>	
Nov. 27.....	Savannah, Ga., Vanderbilt Cup Race, Savannah Automobile Club.
Nov. 30.....	Los Angeles, Cal., Track Races, Motordrome.
Nov. 30.....	Savannah, Ga., Grand Prize Race, Savannah Automobile Club.
Dec. 25-26.....	Los Angeles, Cal., Track Races, Motordrome.

# THE AUTOMOBILE

Vol. XXV

Thursday, November 16, 1911

No. 20

## THE CLASS JOURNAL COMPANY

H. M. SWETLAND, President

CONDE NAST, Vice-President and General Manager

E. M. COREY, Secretary and Treasurer

231-241 West 39th Street, New York City

Cable Address - - - - - Autoland, New York  
 Long Distance Telephone - - - - - 2046 Bryant, New York

### SUBSCRIPTION RATES

United States and Mexico - - - - - One Year, \$3.00  
 Other Countries in Postal Union, including Canada - - - - - One Year, 5.00  
 To Subscribers—Do not send money by ordinary mail. Remit by Draft,  
 Post-Office or Express Money Order, or Register your letter.

Entered at New York, N. Y., as second-class matter.  
 The Automobile is a consolidation of The Automobile (monthly) and the Motor  
 Review (weekly), May, 1902, Dealer and Repairman (monthly), October, 1902,  
 and the Automobile Magazine (monthly), July, 1907.

## A Foreign Solution

**A** FEW years ago when a car maker wanted more power he added to the cylinder bore and stroke; in some cases he added another pair of cylinders, converting the four-cylinder chassis into a six. Often when adding extra cylinder power more weight was added, heavier parts were deemed necessary to care for the additional power, and little thought was given to the matter of reducing the weight of the parts by the adoption of higher grades of steel. In those days if more power was wanted the only solution was more cylinder capacity. This system is changing very rapidly in America, and it has changed wonderfully in Europe. In America the demand for higher efficiency with reduced fuel and other expenses has not been so great as abroad. In England, where there is a tax on gasoline per gallon as well as a registration tax by horsepower, and where many of the buyers have a limited income on which to live and to operate the car, it is necessary for a car maker to practically guarantee the fuel consumption of his machine, to guarantee the hill-climbing ability, to guarantee the speed on level roads and to guarantee the probable tire mileage.

It has been necessary with the English builder, and with a great many French builders also, to give higher motor efficiency with reduced cylinder capacity and with a lower fuel consumption. This has caused the engineering departments to go to work. The result has been that they are using the long stroke abroad because it is more economical on fuel and gives more power proportionately than the shorter stroke variety. In America several of the makers who are to-day experimenting with the long-stroke types say they consume more gasoline than the square motor. It is quite natural that with experimental engines, as many of them are, the fuel economy factor should not be anywhere near the low-level mark. It will take a year or so before consumption is cut down to the minimum. Not only has the foreigner cut down fuel consumption, but he has increased the power.

The long-stroke motor has brought many problems along with it. One has been the reduction in the weight of reciprocating parts, meaning pistons, connecting-rods and wristpins. It is now customary in standard touring cars to fill the pistons below the wristpins with small holes varying in diameter from 1 to 2 inches. These perforations reduce weight very much. Other makers, instead of doing this perforation job, have adopted steel pistons. These steel pistons are stampings. They are very light and are very cheap to make. A little weight has been cut off the wristpins by making them of larger diameter and hollow. The connecting-rod weight has been very materially reduced in many ways. One maker uses a hollow rod. It is expensive, but strong, and the reduced weight gives a smoother running motor. The piston, wristpin and connecting-rod unit has to be stopped and started twice in every revolution of the crankshaft, and when a crankshaft is revolving 1500 revolutions per minute it means 3000 stoppings and 3000 startings of this weight in every minute of time. It takes power to start this weight in movement and increase it to a high speed, and it also takes power to stop it. The heavier these parts are the more power is consumed in this starting and stopping process.

It may be that some car users will say that with lighter reciprocating parts there will be more rocking or pivoting of the pistons and consequently more piston slap and motor noises. This might be true had the designer not anticipated the difficulty, but he has mastered the situation by adding to the length of the piston, so that with the reduced weight and increased length there is a steadier piston than formerly and there is a motor with less piston slap, and consequently less noise.

Much talk is indulged in as to what constitutes a long-stroke motor. Some American car builders advertise long-stroke motors when the bore is 4 inches and the stroke 4.5 inches. Such is not a long-stroke motor. The long-stroke motor should have the stroke at least from 25 to 40 per cent. in excess of the bore. Of the new models brought out in France and England this year the stroke-bore ratio averages 1.5 to 1. There are a few new motors with the stroke a good deal more than half as great again as the bore. There are two or three in which the stroke is double the bore, and one of the more progressive ones has the stroke-bore ratio at 2.75 to 1. Two years ago such constructions were considered racing monstrosities, but to-day it is different. The makers have refined on the racing creations of the past; some are marketing them as the regular product.

The American builder will find that manufacturing a long-stroke motor is not merely adding a few inches to the stroke and cutting off a fraction of an inch or perhaps an inch from the bore. The long-stroke motor is a new design. It is a new conception of a motor and not a working over of an old design. When the stroke-bore proportion is changed the lubrication problem is changed, the valve design problem has been altered, the carburetion work changed, and, in fact, the entire motor situation is altered. The long-stroke motor must be designed from the ground up. It is just about as sensible to make a long-stroke motor out of a square one, in the hope of getting a fair measure of success, as it is to take a touring car chassis and, by changing the gear ratio, transform it into a truck chassis.

# Census Figures on the Industry

WASHINGTON, D. C., Nov. 13—A further preliminary statement of the general results of the thirteenth census of establishments engaged in the manufacture of automobiles, including bodies and parts, was issued to-day by Census Director Durand. It contains summaries which give the general figures, the number and value of machines by kind, for 1904 and 1909, and the horsepower rating by classes for 1909. The report was prepared under the direction of William M. Stewart, chief statistician for manufactures, Bureau of the Census. The figures are subject to such revision as may be necessary after a further examination of the original report.

The summary shows increases in all the items at the census of 1909 as compared with that for 1904.

The number of establishments increased 317 per cent.; capital invested, 653 per cent.; the gross value of products, 730 per cent.; cost of materials, 901 per cent.; value added by manufacture, 596 per cent.; average number of wage earners employed during the year, 528 per cent.; amount paid for wages, 580 per cent.; number of salaried officials and clerks, 682 per cent.; amount paid in salaries, 654 per cent.; miscellaneous expenses, 389 per cent.; primary horsepower, 647 per cent.

There were 743 establishments in 1909 and 178 in 1904, an increase of 317 per cent.

The capital invested as reported in 1909 was \$173,837,000, a gain of \$150,753,000, or 653 per cent., over \$23,084,000 in 1904. The average capital per establishment was approximately \$234,000 in 1909 and \$130,000 in 1904.

The value of products was \$249,202,000 in 1909 and \$30,034,000 in 1904, an increase of \$219,168,000, or 730 per cent. The average per establishment was approximately \$335,000 in 1909 and \$169,000 in 1904.

## Weed Chains Win Another Battle

Another victory for the Weed Chain Tire Grip Company and the Parsons Non-Skid Company, upon the patents on which the former bases its product, was scored in the United States Circuit Court for the Southern District of New York, when Judge Lacombe signed an interlocutory decree affirming the right of the complainants in the patent and issuing a permanent injunction against E. J. Willis Company, of Boston, and waiving the prohibition so as to cover the Whitaker Chain Tread Company also.

The decree appoints Commissioner Shields to take testimony for an accounting between the parties and when that is done the decree may be made final. In the meantime the respondents have the right to appeal the case to the Circuit Court of Appeals, which will probably be done.

The Weed chain makers are in the midst of an extended battle to assert their rights under the Parsons patents and at this time there are still pending 175 suits against various alleged infringers of those patents. In this number of cases preliminary injunctions have been granted while several final decrees have been entered against individual infringers.

The amount of money involved in the present litigation is considerable but it has not been definitely determined and will not be until Commissioner Shields has finished hearing the testimony.

The interlocutory decree connects the Whitaker company with the respondent in this language:

"The E. J. Willis Company without right or license from the complainants making, selling and using chain grips known as the Whitaker Chain Grip made by the Whitaker Chain Tread

Company, which has conducted the case of the respondent."

Frederick S. Duncan conducted the case for the complainants.

The patent under consideration is No. 723,299, granted August 24, 1903.

## Government Investigates Naphthalene

WASHINGTON, D. C., Nov. 13—As a large part of the road work in this country seems destined to be effected by the use of tars in road treatment and construction, a systematic investigation of the effect of various constituents upon the adaptability of tars as road binders is now being made by the Good Roads Division of the Department of Agriculture. While definite conclusions are not announced, the results strongly indicate four determined facts, as follows:

That the fluxing value of naphthalene for tar pitches is somewhat greater, although quite similar, to the heavier naphthalene-free tar distillates, until the mixture becomes saturated with naphthalene.

That for the harder tar pitches the addition of very small percentages of naphthalene will produce a marked increase in fluidity of the resulting product.

That for the softer pitches the addition of naphthalene in small quantities causes less increase in fluidity than for the harder pitches.

## Fifty-four in Savannah Road Races

Extending the time for closing entries to the Savannah road races until November 23 was decided upon yesterday in order to allow several belated entries to reach the authorities.

The list now contains fifty-four cars, divided among the four races as follows: Grand Prize—Benz (3), Fiat (3), Abbott-Detroit (2), Lozier (2), Marmon (2), Mercedes (2), Buick (2), Inter-State (2), Apperson, Ford and Pope-Hummer. Total, 21.

Vanderbilt Cup—Fiat (3), Lozier (2), Mercedes (2), Abbott-Detroit (2), Inter-State (2), Mercer (2), Marmon (2), Opel, Jackson and Ford. Total, 18.

Savannah Challenge Cup—Marmon (3), Mercer (3), Case (2), Ohio and Cino. Total, 10.

Tiedeman Trophy—E-M-F (3), Abbott-Detroit (2). Total, 5.

The course was thrown open for preliminary practice on Monday, and the circuit, which has been reduced to 17.14 miles has been pronounced faster than before by 5 miles an hour.

According to the officials there is a possibility of getting in ten more entries.

James M. Carples, of the New York Mercedes branch house, stated yesterday that the Mercedes entries in the Grand Prize are conditioned upon the showing of the cars in the Vanderbilt Cup race.

The New York official party, consisting of R. L. Morrell, referee, and his associates, left this morning for Savannah.

## Knight Says Argyll Infringes

Cable advices from Coventry, England, declare that Charles Y. Knight has filed suit on behalf of his company against the Argylls, Limited, makers of the Argyll automobile. The complaint alleges infringement of the Knight patent covering the sleeve-valve motor in all its details. The new Argyll is equipped with a single-sleeve device which is given a reciprocating motion, while the original Knight engine has two concentric sleeves. In the Argyll the rotary valve principle is also combined with the reciprocation of the sleeve.

## News of Shows—National and Local

**T**HERE was a little more activity to be noted in the local show situation during the past week than there has been for a month back. The decorative plans are being discussed, and while everything in this line is still tentative at best, the main ideas under consideration embrace the simplest plan of decoration ever used for an automobile show in the preparations of the National Association of Automobile Manufacturers for its display at the Grand Central Palace.

It would be painting the lily to go into any extensive decorations in such a show hall, as the architectural features of the building are so handsome without decoration that something would be detracted from their appearance by the copious use of bunting and lights.

The plan is to install panels over the windows, painted to represent autumn scenes, and to confine the other decorations to vines, greenery and potted plants.

At Madison Square Garden the scheme this year is still indefinite. Several ideas of decorations are under consideration. One of the favorites is an Egyptian theme, which calls for conventional effects and vivid colors.

Complete lists of the exhibitors at both shows are being prepared and will be issued as soon as possible.

The space allotments, at the Palace have been revised several times, the latest change being made necessary by the withdrawal of the Colby & Babcock electric.

So far about forty members of the motor and accessory manufacturers and twenty-five independent makers have taken space in the accessory show, which will be held on the third floor.

All the space for the first week at Madison Square Garden has been taken.

### Milwaukee Show Will Fill Auditorium

**MILWAUKEE, Nov. 13**—The entire Milwaukee Auditorium, affording more than 65,750 square feet of floor space, will be required to house the 1912 motor show of the Milwaukee Automobile Dealers' Association, which will be held from Jan. 13 to 19 inclusive. The main arena, which has heretofore sufficed to contain all pleasure car exhibits, will be supplemented by the arena basement, and the commercial vehicles will be placed in other large halls of the basement. The four smaller halls on the main floor will be used for accessory and parts displays. Bart J. Ruddle, 71 Sentinel building, Milwaukee, is manager.

### Omaha Show February 19-24

**OMAHA, NEB., Nov. 13**—At a second meeting of the directors of the Omaha Automobile Show Association, it was decided to hold the Omaha show from Feb. 19 to 24.

It was decided to hold the show at the auditorium again as it is more centrally located than the Coliseum. But as the auditorium has been too small for the show for the last two or three years, it is planned to build a temporary annex on a vacant space to the south of the building, for the commercial vehicles. This will leave the main floor of the auditorium for pleasure cars.

As there have been thirty-three firms represented in this association, and twelve more are applying for admission, the 1912 show will be by far the largest ever given here.

### Cincinnati Exhibit in Music Hall

**CINCINNATI, O., Nov. 13**—The Cincinnati Automobile Dealers' Association has definitely decided to hold the association's annual

show in the north wing of Music Hall, this city, during the week of February 19 to February 24, for pleasure vehicles only and a separate exhibit for commercial vehicles during the first three days of the following week.

The committee chairman were appointed as follows:

Chairman of all committees, Edward F. Herschede; display, space, tickets, badges and program, Robert T. Crowthers; publicity campaign, E. A. Kruse; decorations, H. S. Leyman; halls and grounds, Frank H. Miller; heating and lighting, W. G. Welbon; concessions, George Behlen.

### Show Dates for Providence

**PROVIDENCE, R. I., Nov. 13**—Dates for the Providence automobile show have been set for January 22-27. The State Armory will be the stage, and passenger and freight cars as well as accessories will be displayed. The floor space of the main hall is 38,000 square feet. The rules as framed are much the same as those in force at all the important exhibitions of automobiles. Arthur S. Lee will manage the show.

### Pittsburg Leases Exposition Building

**PITTSBURGH, PA., Nov. 13**—The Pittsburgh Auto Show Association, incorporated, has leased Exposition building for their second annual automobile show from February 17 to 24, 1912.

The association held its annual election and elected the following officers and directors: E. A. Williams, president; Elias Lange, vice-president; Albert A. Buhl, secretary; Julian B. Howe, treasurer; J. H. McClarren, B. F. Benson, E. E. Gregg, James D. White and L. G. Martin.

As the association will have twice as many members to show as last year, it was found necessary to provide additional space at the Exposition so that all could properly show their cars and trucks. By going to quite an expense, it was found feasible to remove some of the permanent booths and thus provide extra room.

Thomas I. Cochran, who managed the Exposition automobile show for the association last year, has been retained as manager this season. Offices have been leased and fitted up in the Highland building.

Fifty-two makes of pleasure cars and 16 of the highest grades of trucks are handled by the members of this association. The automobiles and trucks will be shown on the same floor in separate aisles. The balcony is large enough to accommodate all the accessory dealers of this section.

The Exposition building is larger than Madison Square garden in New York; in fact, is the largest building used for show purposes in the United States. There is not a pillar or post in the entire building to obstruct the view or interfere with an exhibit.

### Scranton Gets Ready for Show

**SCRANTON, PA., Nov. 13**—The Scranton Annual Automobile Show will be held in the 13th Regiment Armory from Monday, January 29, to Saturday, February 3, 1912, as the former show was cramped for room in the Town Hall. The 13th Regiment Armory, one of the best in the State, has been secured for the present show. Forty thousand square feet of floor space will be used, and nearly all this space has been taken. About 100 automobiles, and a large line of accessories, will be exhibited. Hugh B. Andrews, who so successfully managed the initial show here, will manage this year's exhibition.

# How Chicagoans Will Sell Used Cars

**C**HICAGO, Nov. 13—Having worked on the problem for a month, the Chicago Automobile Trade Association today, at a general meeting of the association, adopted the report of the special committee appointed to look into the second-hand car proposition, which report had previously been carefully considered from various angles and then favorably acted upon by the directors.

The Chicago idea is different from those in vogue in other cities in that it does not attempt to bind the dealers by iron clad contracts—it simply furnishes a source of information which will be of value to the tradesmen in setting prices on old cars offered as part payment on new ones. The scheme as outlined is as follows:

First—There shall be established a bureau of information to be conducted under the direction of the directors of the association.

Second—The association shall have prepared blank forms arranged to receive a list of all models made by any one manufacturer for the year 1908, and each subsequent year, including model, number of passengers, type of motor, selling price when new, allowance price for each model in average condition, and resale price when thoroughly overhauled.

Third—These blanks forms shall be distributed to all dealers, and each dealer shall file such forms, properly filled out, giving the above information, with the secretary of the association.

Fourth—Thereafter on the first of every month each dealer shall file with the secretary a revised card showing any changes in prices or models.

Fifth—The association shall have copies of each report or revised report printed in quantity sufficient to furnish one or more to each member of the association; suitable loose leaf binder covers shall also be obtained, marked on the outside with the name of the association, in which a copy of each report shall be placed alphabetically arranged; a copy of these reports so bound shall be furnished by the association to each of its members.

Sixth—The association shall furnish each member with a printed copy of each revised report thereafter filed with it by any dealer; and for this purpose the association shall employ a messenger whose duty it shall be to deliver these revised reports to each member, personally placing the new sheets in each binder, and returning the old sheets to the secretary of the association.

Seventh—These binders shall be the property of the association at all times, and shall be renewed by it whenever necessary.

Eighth—A committee of three members of the association shall be appointed by the president each year immediately after the election of officers.

Ninth—It shall be the duty of this committee, whenever any member fails to file the reports provided for by these rules, to obtain, by any means that they may consider appropriate, sufficient information to enable them to prepare and file with the secretary a report similar to a dealer's report, which shall be received in lieu of the report of the particular dealer.

Tenth—Whenever any member shall sell a second-hand car, such member shall immediately report by mail to the association, filling for that purpose a blank form, to be furnished by the association, which shall read as follows:

"I, today sold.....second-hand car model..... number of passengers..... price when new..... for \$..... Signed..... Dated....."

Eleventh—The association shall have compiled weekly a list of all sales of second-hand cars reported each week, model and price, and a printed copy of this list shall be mailed to each member; the names of the dealers selling the cars shall not be made public, but kept on file by the association for its records.

Twelfth—The association shall also obtain information from all possible sources to enable it to print weekly a list of the number of the various models and makes of second-hand cars on sale in the hands of members. A copy of such lists shall be mailed to each member.

Thirteenth—Each member of the association shall render all possible assistance to the association in obtaining this information and shall furnish it with complete lists of all cars on hand for sale.

Fourteenth—Each member after completing a trade for any second-hand car shall immediately report by mail to the association, filling in a blank form, to be furnished by the association, which shall read as follows: "I, today, took a second-hand car, model..... allowing \$..... as part payment on a new car. Signed..... Dated....."

Fifteenth—Each member shall make all quotations on second-hand cars to their customers in writing, and shall mail a copy of such quotation, omitting the name of the customer, to the association upon forms to be supplied by the association.

Sixteenth—The association, through its secretary, shall furnish to any of its members, on request, the amount that any dealer has allowed for any second-hand car or any quotation made by any dealer to a prospective

customer on any second-hand car, using for this purpose the information obtained from the reports provided for in clauses 14 and 15.

Seventeenth—The expense of obtaining and furnishing the information provided for in the preceding clauses 1-15, shall be divided pro rata among the members of the association dealers in motor cars.

## Pullman Owners Tour to Factory

**YORK, PA., Nov. 13**—The first sociability run of the Pullman Automobile Company, Philadelphia, was held to-day from the Quaker City to York, and fifteen Pullman cars were entered by owners from Philadelphia and Reading.

W. L. Garland, driving a 1911 Model K Pullman, won the run. His time for 89 miles was 5:03.30. The time for the run had been fixed at 4 hours, 56 minutes and 10 seconds. Mrs. W. G. Preston, Philadelphia, won the ladies' prize for guessing closest to the elapsed running time. Her guess was 4 hours and 56 minutes. I. S. Cohen, of the Philadelphia Taxicab Company, came within 30 seconds of winning the first prize, he making the distance in 5 hours and 4 minutes. The route was via Paoli, Coatesville, Lancaster, Columbia and York.

## The Longest Oil Truck

**M**UCH interest has been shown in a new oil wagon truck recently put into service by the Standard Oil Co. It is a Longest, manufactured by Longest Bros. Co., of Louisville, Ky., it being one of their standard designs with a few alterations to minimize any danger of igniting the inflammable oil which is carried. The large tank is divided into four compartments, each carrying about 250 gallons of oil; the box on the rear carries the measures, funnels, etc.; the brass rails on the sides are designed to carry cases, cans of oil and boxes of grease.

The manufacturers of this truck call it their 3- to 4-ton model. The motor is four-cylinder, four-cycle, 5-inch bore and 5 1-2-inch stroke, 40 A. L. A. M. horsepower. Bosch magneto and Stromberg carbureter are used. The wheel base is 144 inches and the tread 68 inches. The tires used are 36 x 4 on the front and 36 x 4 dual on the rear. The fuel supply for the motor is a 27-gallon tank located under the driver's seat, the gasoline flowing to the carbureter by gravity. The approximate weight of the complete outfit is 7000 pounds.

The design of this truck has been much admired; mechanically it has every appearance of being well and strongly built and its lines are very impressive. The Longest Bros. Co. makes the motors, transmissions, wheels, radiators, and practically all parts used in the truck's construction. The 3-ton truck of standard design sells for \$3,500, while the 5-ton vehicle sells for \$4,000.

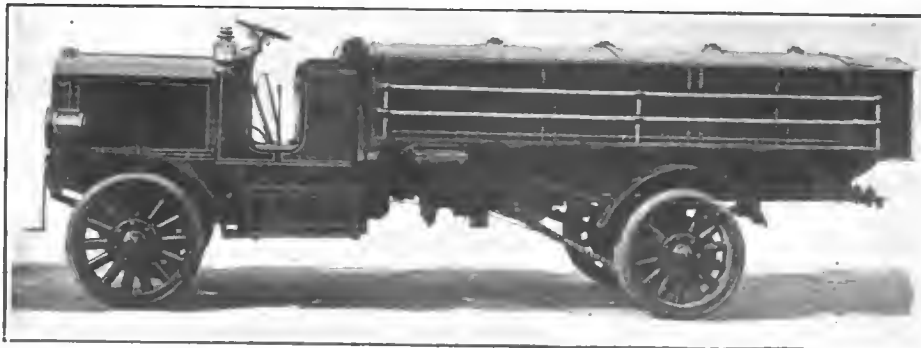

New oil truck built by the Longest Bros. Co., of Louisville, Ky.





CONVENTION OF SWINEHART SALESMEN AND BRANCH MANAGERS AT THE GENERAL OFFICES AT AKRON, O.

Top Row, left to right—A. T. Barder, Chas. J. Parker, W. K. Gardner, J. F. Lemmon, G. L. Moore, F. C. Grant, E. Flagg, Jr.; C. A. Swinchart, J. G. Boss, W. E. Boyle, W. J. Kreuder, H. L. Houk, G. A. Dodge. Middle Row—M. J. O'Connor, B. T. Hadley, L. H. Brainard, F. E. Partridge, C. O. Dail, Louis J. Long, Mr. Gray, F. H. Pierce, G. E. Grimes, J. A. Kuehlhorn, A. T. Carnahan. Bottom Row—F. D. Wait, E. O. Hoopenganger, J. J. Thompkins, A. J. Green, W. W. Wuechter, R. A. May, C. O. Baughman, C. W. Harria, S. G. Andrews, F. H. Burgher

**S**T. LOUIS, MO.—Local dealers are in a controversy with the Secretary of State in regard to the legality of the practice of issuing pasteboard duplicates of the dealer's license to purchasers of new cars, for use until the State license has been obtained. The Secretary of State recently announced that any motorist using a pasteboard tag would be subject to arrest and fine. The dealers declare their intention of testing the question in the courts, if necessary.

**NEWARK, N. J.**—An automobile repair plant will be erected here by Eisele & King.

**BOSTON, MASS.**—W. V. Bennett is the latest addition to the salesforce of the local Grout branch.

**LIMA, O.**—The A. D. Maus Auto Company of 114 East Elm street has taken the agency for the 1912 Mitchell.

**WASHINGTON, D. C.**—The C. B. McAlister Company has secured the Ford agency for Washington county.

**AKRON, O.**—The Swinehart Tire & Rubber Company of this city will erect a new building next to its present plant.

**St. LOUIS, Mo.**—Announcement is made that the Mound City Buggy Company is to handle the Jackson in this vicinity.

**LEIPSIC, O.**—The American Foundry Company of this city has changed its name to the Temco Electric Motor Company.

**KANSAS CITY, Mo.**—The Auburn Motor Car Company has removed to the corner of Sixteenth street and Grant avenue.

**BUFFALO, N. Y.**—The Thomas Motor Car Company, of this city, has increased its capital stock from \$50,000 to \$100,000.

**NEW YORK CITY.**—The Poertner Motor Company has taken the agency for the Herreshoff line of small cars for this district.

**WILMINGTON, DEL.**—The Auto Sales Company, a local concern, has begun the manufacture of a motor truck of its own design.

**St. LOUIS, Mo.**—The Kisselkar branch, of which George Dunville is manager, has taken new quarters at 3008 South Grand avenue.

**MILWAUKEE, Wis.**—The Federal Rubber Company of Cudahy, has purchased a site for a new office building, which will cost \$18,000.

**SAN FRANCISCO, CAL.**—W. A. Baker of Seattle, Wash., has joined the forces of Don Lee, the local distributor of the Cadillac.

**PITTSBURGH, PA.**—The Ohio Motor Car Company of Elmwood - Cincinnati has named the Federal Motor Company as local agent.

**RICE LAKE, Wis.**—The Automobile Trip Carrier Company will build a 50 x 120-foot

brick addition to its factory at once, near the foundry building.

**BOSTON, MASS.**—The R. L. and H. H. Smith Company, distributor of the Selden cars and the Mais truck, intends to establish a service department.

**MONTREAL, CAN.**—Scott and Pease have opened a showroom at 632 Saint Catherine street, West. They are agents for the Baker Electric and for the Pope-Hartford.

**GRAND RAPIDS, MICH.**—The Silverman automobile factory to be built in this city will be two stories high, with basement, and will measure 59 by 100 feet. It will cost \$10,000.

**MUSCATINE, IA.**—Bowman Brothers have enlarged their garage and salesroom on Front street and have contracted with the Buick company for their line for 1912 for Muscatine and Louisa counties.

**ROANOKE, VA.**—The Virginia Motor Car Company is having plans prepared for the erection of a fireproof garage, 50 by 154 feet. The building will be equipped with a turntable and electric elevator.

**MANSFIELD, O.**—C. H. Voegele has taken the agency for the Velie car for this vicinity. He is building a large garage for the purpose of handling Velie freight automobiles as well as pleasure vehicles.

**WASHINGTON, D. C.**—R. C. McDowell, of Miller Brothers' automobile supply house,

has been appointed superintendent of the garage on Church Street owned by the firm.

ALEXANDRIA, VA.—The B. F. Board Motor Truck Company is planning to erect an addition which will increase the capacity of the plant from 200 to 400 trucks a year.

ST. PAUL, MINN.—According to records in the office of the Secretary of State, there are 19,206 automobiles in use in Minnesota. They are valued at approximately \$2,000,000.

GALESBURG, ILL.—The firm of Hobbie and Martin has passed into the hands of W. P. Martin who will continue to carry on the business under the name of the Central Garage.

SYRACUSE, N. Y.—The Chase Motor Truck Company, of this city, expects to begin operations in the new 3-story factory addition on Wyoming street about the end of next month.

BOSTON, MASS.—The Hollander Motor Car Company, agent for the Metz car in New England, has moved into its new building on Boylston Street, near Massachusetts avenue.

KANSAS CITY, Mo.—The local branch distributing house and service station of the Remy Electric Company has been moved from 416 East Fifteenth street to 509 East Fifteenth street.

SAN FRANCISCO, CAL.—J. D. Anderson, general sales manager of the United States Tire Company, is inspecting the branches which the company has opened on the Pacific Coast during the past few months.

NEW YORK CITY.—American-made tires to the value of \$1,715,322 were exported during the first eight months of this year. In August the exports of tires were \$251,262, a gain of over \$100,000 over August, 1910.

CINCINNATI, O.—Charles C. Craig, formerly connected with the Chicago branch of the Haynes Automobile Company, has assumed the position of sales manager for

the Enger Motor Car Company of this city.

KANSAS CITY, Mo.—Christian & Company, formerly agents for the Hupmobile and Hupp-Yeats Electric, have been succeeded by the Hupmobile Sales Company of Kansas City. C. C. Christian is manager.

CHICAGO, ILL.—Charles V. Severin, who has been connected with the automobile industry for the past 7 years, has been placed in charge of the service department of the local branch of the Velie Motor Car Company.

CLEVELAND, O.—The F. B. Stearns Company, of this city, has rented the factory of the Royal Tourist Motor Car Company, E. 72nd street and St. Clair avenue N. E., which in future is to be operated as Stearns plant No. 3.

CHICAGO, ILL.—The Lininger Implement Company of Omaha, Neb., will represent the Lincoln Motor Car Works of this city throughout Nebraska and Wyoming. It will act as distributor for the Lincoln light delivery wagon.

AKRON, O.—The Goodyear Tire & Rubber Company of this city will occupy the last of its series of new buildings in three weeks. The latest addition is to be occupied by stock and the shipping department of the company.

NEW YORK CITY.—Melvin J. Adams, formerly of the United States Motor Company, has joined the advertising department of the American Locomotive Company. Mr. Adams will assist in the preparation of the Alco literature.

SYRACUSE, N. Y.—A. D. McLachlan, formerly connected with the Royal Tourist Motor Car Company, of Cleveland, O., has resigned and has accepted the position of general sales manager with the Sangford-Herbert Company, of this city.

KENT, O.—The prospects for the building of a new automobile works in the city are very favorable. As soon as enough of the lots have been paid for to warrant

building, the Criterion Motor Car Company of Pittsburgh, will erect its factory.

INDIANAPOLIS, IND.—The International Metal Polish Company of this city has broken ground for a new factory. The new building will be of brick, with inside construction of reinforced concrete.

WILMINGTON, DEL.—Elaborate preparations have been made by the Delaware Automobile Association for its annual banquet, which will be held Friday evening at the Clayton House. Covers will be laid for 200 persons.

PORTLAND, ORE.—S. C. Houston, associated with the sales force of the White Motor Car Company, has been duly installed as manager, succeeding C. A. Eastman, who will now head the sales force and devote his entire attention to the selling of cars.

CINCINNATI, O.—The Fisher Motor Car Company, successor to the Speedwell Motor Car Company of this city, has leased the modern garage and salesrooms located at 804-808 Sycamore street for 6 years. The lessee is a representative of the Speedwell car.

CLEVELAND, O.—Upon the application of the Panama Rubber & Supply Company, the Columbia Refining Company, the Cleveland Auto Top & Trimming Company, and the M. & M. Company, A. J. Schur has been named receiver for the Kissel Kar Company, of this city.

INDIANAPOLIS, IND.—The commissioners of Washington county, Ind., have purchased that part of the toll road running through the county. The road, which has been operated for many years by the New Albany and Paoli Turnpike Company, will become a free turnpike.

RACINE, WIS.—The Holbrook-Armstrong Company of this city is building three chassis from designs by a Chicago concern. Reports that the company will engage in the business of building complete cars are denied although practically all parts are now being made.

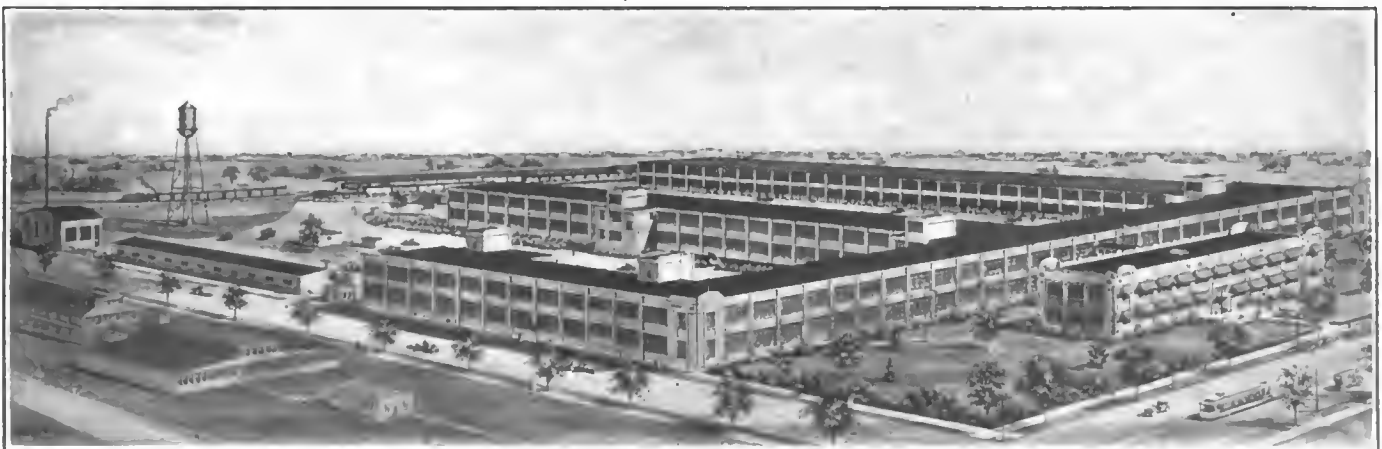

New plant now in course of erection on Jefferson Avenue, Detroit, for the Hudson Motor Car Co.

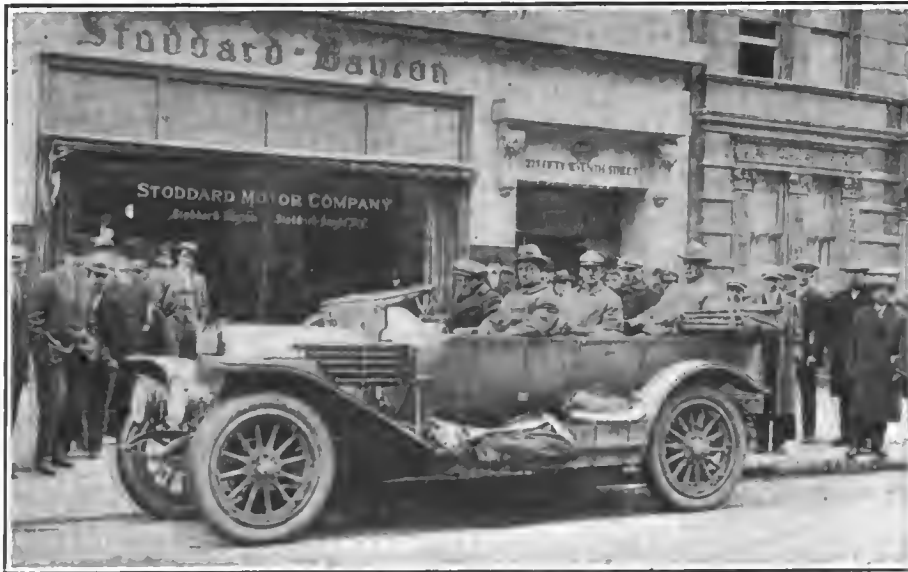

B. O. Tilden's transcontinental Stoddard-Dayton car at the finish of its 26,000-mile tour in the interest of sanitation

INDIANAPOLIS, IND.—Thomas Marshall of Detroit, Mich., has been appointed general manager for the United Motor Indianapolis Company. He succeeds Jack Hayden, who has been obliged to retire on account of ill health.

INDIANAPOLIS, IND.—Suits brought in the federal court here by Thomas J. Lindsay and Willard Harmon against the Cadillac Automobile Company and the Westcott Motor Car Company have been dismissed. Infringement of patents covering a bevel-gear floating type of axle was charged.

CAMBRIDGE, ILL.—P. A. Johnson, who has the Maxwell line for Henry, Stark and Peoria counties for the coming season, will have a garage and salesroom in Peoria for 1912. Mr. Johnson will assume the management of the Cambridge office and devote part of his time to the Peoria office.

AKRON, O.—John W. Thomas, newly-appointed general superintendent of the Firestone Tire & Rubber Company, was inducted into office with a banquet of department heads of the company last week. The position which Mr. Thomas occupies is one that has been created by business growth.

NEW YORK CITY—Albert J. Ditman, who has been connected with the sales department of the Studebaker Company for eight years, has become a member of the firm of the Whiting Motor Company which handles the Cunningham and Mercer cars and the Sandusky motor truck at 1802 Broadway.

ST. LOUIS, MO.—The addition which the Moon Motor Car Company is making to its factory will increase the capacity of the plant 25 per cent., though owing to the fact that the space will be used to relieve the congested departments, it will increase the capacity of the factory, as far as production is concerned, 40 per cent.

BOSTON, MASS.—Fred Harrington, well known in local motor circles, has entered the commercial field and is now a member of the salesforce of the Robert Harrison Motor Truck Company of South Boston.

COLUMBUS, O.—J. A. Sherer, registrar of the Ohio State Automobile Department, has received applications for about 1200 sets of number plates for 1912 registration. Up to date the department has distributed 45,671 sets of number plates for 1911 registration or more than 10,000 ahead of the number given out in 1910.

CLEVELAND, O.—During the past few weeks the F. B. Stearns Company of this city has added the following representative dealers to its list: The Pence Automobile Company of Minneapolis, Minn.; the Fisher-Gibson Company of Indianapolis, Ind., and the McDuffee Motor Car Company of Denver, Col.

INDIANAPOLIS, IND.—The Hoosier Motor Club of Indianapolis has been incorporated. Incorporators named in the charter, which is granted under the voluntary association act without capital stock, are Charles A. Bookwalter, H. O. Smith, Joseph W. Selvaage, C. W. Sedwick, N. H. Price, Bert A. Boyd and Homer McKee.

SAN FRANCISCO, CAL.—R. H. Ingersoll has been appointed manager of the Keaton Vulcanizing Works, distributors of Swinehart tires in northern California. For the past few years he has been manager of the Diamond Rubber Company's uptown branch. That position has now been filled by the appointment of J. A. Jones.

LOS ANGELES, CAL.—J. M. Cummings, manager of the western district of the Michelin Tire Company, has opened a sales warehouse at 749 South San Pedro street in this city. Business will be conducted on the wholesale plan. J. C. Wells, formerly of the San Francisco branch, will be in charge.

ANDERSON, IND.—Roy Watts, well known in the gas engine trade, has joined the forces of the Remy Electric Company, of this city, as a special traveling representative. Mr. Watts was formerly power apparatus manager and engineer for the Western Electric Company.

BUFFALO, N. Y.—The Whyland-Nelson Motor Car Company has established its plant at 49-53 Illinois street, this city, where it will manufacture light-weight passenger automobiles with convertible light delivery car attachment. Frank V. Whyland, formerly with the Superior Motor Truck Company, is president and manager.

GENESEO, ILL.—Weimer's Garage has taken the Overland line for part of Henry County. I. N. McBroom has taken on the entire Clark line for all of Henry and part of Mercer counties for the coming season. The Geneseo Garage has made arrangements with the P. W. Kempster Company, of Prophetstown, Ill., to handle part of Henry County on the Buick line.

SYRACUSE, N. Y.—At the annual meeting of the stockholders of the Chase Motor Truck Company, Nov. 8, the following directors were elected: A. C. Chase, A. M. Chase, L. O. Bucklin, H. P. Bellinger and E. C. Witherby. The directors elected the following officers: President, A. M. Chase, vice-president, H. P. Bellinger, and secretary and treasurer, E. A. Kingsbury.

BEAVER DAM, WIS.—E. O. Parker, president of the Waldron Automobile Manufacturing Company, of Waldron, Ill., is negotiating with the Beaver Dam Advancement Association for the removal of the plant to this city. The company manufactures a combination motor car for business and pleasure purposes, farm tractor, stationary engine, etc. Beaver Dam is an agricultural implement center.

WALTHAM, MASS.—The Metz Company of this city has secured another building near its plant—the former home of Gov. Gore of Massachusetts. The general offices have been transferred to this building which will be used as an administration headquarters, giving the space in the factory over to manufacturing. Next spring the company plans to build a new structure on the recently acquired ground.

SAN FRANCISCO, CAL.—John H. Eagal, vice-president of the Oldsmobile Company of California and manager of the Oldsmobile branch in Los Angeles, has been appointed general Pacific Coast representative of the Olds Motor Works, of Lansing, Mich., and manager of the new San Francisco branch. David L. Whitford has been transferred from San Francisco to Los Angeles, where he will be in charge of the Southern California territory. Eagal's district will be California, Oregon, Washington, Idaho, Nevada and Arizona. W. Folberth, the Oldsmobile factory engineer, will make his headquarters in San Francisco.

BALTIMORE, Md.—Since Commissioner of Motor Vehicles John E. George took office a net fund from motor car licenses has been turned over to the State treasury. One-fifth of this amount goes to the city of Baltimore and the remainder to the various counties for oiling, maintaining and repairing modern roads being built throughout the State.

COLUMBUS, O.—The Ohio State Automobile Department is preparing to move from the Harrison building on High street to the New Hartman building, corner of State and Third streets. Several rooms have been leased on the third floor for the executive and bookkeeping offices and a room on the ground floor will be used as a shipping-room for the number plates. The department will be moved about December 1.

NEW YORK CITY—The Packard Motor Car Company, of Detroit, has sold \$2,000,000 5-year, 5 per cent. notes, maturing Dec., 1916, to W. A. Read & Company. These notes are a first claim on the assets of the company, which are carried on the books at over \$15,000,000. The purpose of the company in selling these notes was to retire bank loans incurred in financing development and expansion work, and to provide additional working capital.

BOSTON, MASS.—Manager Harold D. Bornstein, of the New England branch of the Velie, has arranged to move about January 1 from his present quarters on Massachusetts avenue to a building on Boylston street, now being remodeled. The lease of the present quarters does not expire until next September, but as the Stoddard-Dayton Company is to take it over Manager Bornstein decided it would be a good plan to move as soon as possible.

BOSTON, MASS.—The local branch of the Velie Motor Car Company has appointed the following as agents for the Velie: The Shean Auto Station for Springfield, Mass., and vicinity; Amos J. Shorey for Bangor, Me., and northern Maine; J. T. Curtiss & Company for Hartford, Conn., and southern Connecticut; George H. Snell for Attleboro, Mass., and vicinity; Arthur Beharrell for Lowell, Mass.; Walter B. Johnson for the State of Vermont; Lord Bros. for Tifton, N. H., and vicinity.

BOSTON, MASS.—Manager Pruden of the New England branch of the Kissell Kar Company has approved plans for a new building to be erected for the company on Commonwealth avenue. It will be two stories in height and 200 feet long, giving ample room for salesrooms and a service depot. While the new building is being erected the branch will move temporarily to the motor mart in Park Square, as the J. W. Maguire Company, agent for the Pierce Arrow cars, located next door, has leased the present quarters of the Kissell Kar Company as an addition to its salesrooms.

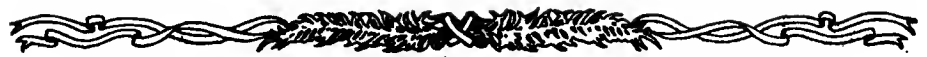

## Automobile Incorporations

### AUTOMOBILES AND PARTS

BROOKLYN, N. Y.—Bedford-Bergen Auto Exchange; capital, \$25,000; to manufacture machinery for automobiles. Incorporators: Ralph Brown, Max Keve, Chas. Goldstein.

BOSTON, MASS.—White, Binford & Robenson Motor Co.; capital, \$20,000; to manufacture automobiles. Incorporators: Albert C. White, Jr., Cecil P. Robenson, Henry O. Cushman.

BUFFALO, N. Y.—Whyland-Nelson Motor Car Co.; capital, \$10,000; to make automobiles and engines. Incorporators: Frank W. Whyland, Joel W. Nelson.

CHARLESTON, S. C.—Kanawba Auto Truck Co.; capital, \$50,000; to build and sell freight automobiles. Incorporators: W. S. Roberts, J. L. Sydenstricker, George F. Gates, D. S. Gunther.

COLUMBIA, S. C.—Consolidated Auto Co.; capital, \$5,000; to sell automobiles. Incorporators: J. B. Roddey, John J. Cain and others.

COLUMBUS, OHIO—Union Sales Co.; capital, \$500,000; to manufacture automobiles.

MARION, IND.—Auto Machine Co.; capital, \$10,000; to make and repair automobiles. Incorporators: G. D. Lindsay, B. A. Tong, R. E. Breed, Jr.

PITTSBURGH, PA.—Large Motor Truck Co.; capital, \$25,000; to manufacture freight automobiles. Incorporator: Edwin L. Atkinson.

PITTSBURGH, PA.—R. C. H. Auto Co.; to sell automobiles. Incorporator: Kenneth S. Burley.

PITTSBURGH, PA.—Krupp Motor Co.; capital, \$250,000; to make automobiles and engines of all kinds.

ROME, GA.—Seay-McCarthy Automobile Co.; capital, \$3,000; to sell automobiles. Incorporators: S. R. McCarthy, R. M. McCarthy, John L. Seay.

ST. LOUIS, MO.—Mack Motor Truck Co.; capital, \$25,000; to make freight automobiles. Incorporators: William R. Busb, Frank J. Busb, Knox Taussig.

SEWARREN, N. J.—Motor Vehicle & Marine Construction Co.; capital, \$15,000; to make automobiles. Incorporators: Henry E. Acker, Albert B. Boynton, William C. Muir.

SPRINGFIELD, MASS.—Western Massachusetts Cadillac Co.; capital, \$10,000; to sell automobiles. Incorporators: Edward R. Clark, Robert A. Knight.

SYRACUSE, N. Y.—Francis Motor Sales Co.; \$5,000; to sell automobiles. Incorporators: Guy

M. Francis, Richtmeyer Hubbell, Chas. E. Nichols.

NEW YORK CITY—Volkmar Auto Starter Co.; capital, \$20,000; to manufacture automobile starting devices. Incorporators: Bernhard Volkmar, Edward Giegerich, Wm. H. Giegerich.

### AUTOMOBILE GARAGES AND ACCESSORIES

BALDWIN, N. Y.—Baldwin Garage; capital, \$1,000; to conduct a general garage business. Incorporators: Charles H. Southard, Mary A. Southard, Wilford S. Southard.

BIRMINGHAM, ALA.—Auto Tire & Cycle Co.; capital, \$2,000; to manufacture automobile tires. Incorporators: Reese Stansel, W. R. Grimes.

BRADDOCK, PA.—Miles Motor Tire Spring Co.; capital, \$200,000; to make automobiles and trucks. Incorporators: Chas. W. Dressler, Thomas G. Aten, Chas. L. Balsayer, Zenob A. Delwart, Fred Miles, M. R. Myers.

CHICAGO, ILL.—Motor Service Corporation; capital, \$10,000. Incorporators: R. Oebmig, F. B. Burl, F. R. Page.

CINCINNATI, OHIO—Fisher Auto & Service Co.; capital, \$30,000; to deal in automobiles, trucks, garages, accessories and to do a general garage business. Incorporators: Arthur F. Fisher, H. J. Guckenberger, George C. Bauer, George Guckenberger, William J. Fleming.

CONNEAUT, OHIO—Trio Horn Mfg. Co.; capital, \$25,000; to manufacture automobile horns and other accessories. Incorporators: Ira E. Stump, B. E. Thayer, W. A. Middleton, Fred Eckert, F. B. Kavanaugh.

INDIANA HARBOR, IND.—Central Auto Supply Co.; capital, \$600; to deal in automobile supplies and accessories. Incorporators: C. C. Robinson, F. E. Stephens, B. S. Gardner.

NEW YORK CITY—Advance Motor Express Co.; capital, \$5,000; to rent automobiles, express and transfer wagons. Incorporators: H. S. De Camp, H. L. Graft, J. I. Doherty.

NEW YORK CITY—Trautman Air Rubber Tube Co.; capital, \$100,000; to manufacture automobile tires. Incorporators: Ira Trautman, August V. Denis, Wm. G. Newball.

NEW YORK CITY—Automobile Sundries Co.; capital, \$10,000; to make and sell automobiles, accessories and supplies. Incorporators: Geo. F. Merritt, John E. Waltz, Tho. M. Crisp.



Building of the Pence Automobile Co., Stearns-Knight distributors in Minneapolis



# OF INTEREST *to the* INDUSTRY



Type of pay-enter motor bus made by the White Company for Indianapolis company

**INDIANAPOLIS, IND.**—The Rapid Transit Motor Company has begun the operation of a motor bus line on North Meridian street, one of the finest residence districts in the city. The chassis of these vehicles are of the 1½-ton class made by the White Company, of Cleveland, O. The buses are of the pay-as-you-enter type, seating eighteen passengers each. They are provided with electric fans for summer service, while a heating system is installed for winter use. The route they will cover is 3½ miles long, and each fare is 10 cents.

**PONTIAC, MICH.**—The Welch Motor Car Company will begin work at once on an addition to its factory. It will measure 40 x 100 feet.

**JEFFERSON, WIS.**—Ground has been broken here for the new plant of the Kenzler-Waverley Motor Company. It is to be 60 x 100 feet.

**JERSEY CITY, N. J.**—The Autoparts Manufacturing Company has removed from 56 Pine street, New York, to 810 West Side avenue, in this city.

**DETROIT, MICH.**—Joseph E. Warren has been appointed chief of district managers for the Metzger Motor Company of this city which manufactures the Everitt car.

**HAMILTON, ONT.**—The Republic Motor Car Company has completed foundations for two factory buildings to measure respectively 60 x 300 feet and 80 x 100 feet.

**ST. LOUIS, MO.**—The General Novelty

Company, manufacturer of Bullfrog horn reeds, has removed to Twenty-third and Locust streets, with the Auto Parts Sales Company.

**PHILADELPHIA.**—Ballinger and Perrot, architects, are preparing plans for a \$100,000 automobile factory which the Otto Gas Engine Company contemplates erecting at Mount Holly.

**ANDERSON, IND.**—The Remy Electric Company of this city has purchased the plant and patents of the R. G. Peters Company of Grand Rapids, Mich., and the Peters plant will be consolidated with the one here.

**INDIANAPOLIS, IND.**—The American Motors Company has moved part of its factory organization into the new building at Meridian street and Belt railroad in this city. All the buildings previously occupied are retained.

**DETROIT, MICH.**—The Metzger Motor Car Company, which makes the Everitt car, is rapidly pushing to completion the addition to its factory. The building will be finished and ready for occupancy within the next 30 days.

**TOLEDO, O.**—The Champion Spark Plug Company of this city has purchased a 1 1-2 acre building site on the Lake Shore and Michigan Central Railroad and is constructing a modern, fireproof plant. The company has also placed orders for a large addition to its automatic machinery equipment.

**AKRON, O.**—The Goodyear Tire & Rubber Company, closed for three weeks to

make changes in equipment and prepare for the Winter season of 1912, resumed operations Nov. 1, with 2,500 men. Officers of the company say the busiest season in the company's history is at hand. The recent improvements and additions give 1,000,000 feet of floor space for use in the new campaign.

**ST. LOUIS, MO.**—The new pumping station to be erected in this city by the Prest-O-Lite Company will occupy a site 180 x 475 feet on the south side of Duncan avenue, between Vau-deventer avenue and Sarah street. It is the intention to have the St. Louis station take care of the middle and southwestern territory in repairing and recharging gas tanks.

**SYRACUSE, N. Y.**—Robert M. Barker has been made advertising manager of the Chase Motor Truck Company of this city. Mr. Barker is a graduate of Harvard, has traveled widely and his experience in the advertising field has been extensive.

**OOSTBURG, WIS.**—The Yale Mfg. & Sales Company, Manufacturers' Home building, Milwaukee, which manufactures automobile accessories and signal devices, has purchased the buildings and real-estate of the Oostburg Foundry Company, and will move its manufacturing plant to this place. The general offices will remain in Milwaukee.

**MOLINE, ILL.**—Benefits amounting to \$1614 were paid out during the last fiscal year by the Velie Employes' Aid Association, according to the treasurer's report at the annual meeting of the society. Benefits were paid to 115 members of the association, which is composed of 300 employes of the Velie Carriage and Velie Motor Vehicle Works.

**WAKEFIELD, MASS.**—At the regular town meeting held this week a special committee appointed to investigate motor apparatus for fire departments sent in its report that a combination chemical and ladder truck costing \$5800 should be added to the town's fire equipment. It is to be kept at the central station. The town now has a motor chemical and a motor hose wagon. The committee's report will be accepted.

**WASHINGTON, D. C.**—The Pope Automobile Company, agent for the Pope-Hartford, Columbus Electric and Marathon, is making extensive improvements in its salesrooms at 817-19 Fourteenth street, N. W.

**CHARLOTTE, S. C.**—The Diamond Rubber Company, of Akron, O., has opened a sub-branch under the temporary direction of J. F. Banier.



# PATENTS GONE TO ISSUE

**CONTROLLING MECHANISM**—A steering wheel for operating steering knuckle and carbureter throttle.

5. The patent refers to a mechanism as shown in Fig. 1, comprising the combination of a steering-post with a rotatable shaft for controlling the movement of the carbureter throttle. This shaft is rotated through an oscillating lever arm. A rotatable shaft serves to actuate the spark-controlling device, and a hand grip carried on the upwardly extended axis of the rotatable lever abovementioned to rotate the shaft. The hand grip may be made to operate the lever which moves simultaneously with it, while it is capable of being rotated on its axis independently of the movement of the lever arm.

No. 1,007,673—To Howard E. Coffin, assignor to E. R. Thomas Detroit Company, Detroit, Mich. Granted November 7, 1911; filed August 4, 1906.

**LIQUID FUEL ENGINE**—In which the crankcase serves as a compression chamber for air.

1. This engine (Fig. 2) consists of a cylinder and a casing secured thereto to form a crankcase, which is provided with an inlet valve. A piston rotating in the cylinder compresses air in the crankcase, which communicates with the cylinder through a pipe containing an evaporator. This is heated by the hot gases exhausted from the cylinder. A metal gauze net is inserted in the pipe, between crankcase and evaporator, and the pipe is provided with a pit forming part of the channel between the metal gauze and the evaporator to collect waste fuel from the latter.

No. 1,008,199—To Olaf Leonhardt Riegels, Christiania, Norway. Granted November 7, 1911; filed February 16, 1909.

**INTERNAL-COMBUSTION MOTOR**—Cylinders are in opposed position and each pair served by common means.

2. The patent relates to a multi-cylinder engine (Fig. 3) consisting of a base.

a number of cylinders arranged in pairs with each two cylinders of a pair in angular relation, a crankshaft in the base with a single throw for each pair of cylinders and means for actuating the valves of the engine cylinders. These means are: a camshaft which is journaled on the casing between the cylinders of the pairs parallel to the shaft and a cam on the camshaft for each pair of cylinders. A cover is detachably secured on the casing over the camshaft and has guide apertures parallel to each cylinder in the plane of rotation of the cam provided for it. A finger is provided whose inner end is journaled in mating half-bearings formed in the meeting faces of the cover and base, and whose outer end bears on the camshaft in the plane of rotation of the cam; there is one valve tappet-rod for each cylinder, and it is adapted to reciprocate in the guide parallel to the cylinder. A plunger for a companion cylinder is reciprocable in the companion guide aperture of the cover with its inner end resting on a finger between the ends thereof.

No. 1,007,842—To Ellsworth H. Belknap and John W. Swartz, Detroit, Mich., assignors to Golden, Belknap and Swartz Co., Detroit, Mich. Granted November 7, 1911; filed September 15, 1910.

**ACETYLENE GENERATOR**—A system applicable to the generation of large quantities of acetylene gas.

3. The apparatus protected by this patent (Fig. 4) comprises an acetylene generator in which is mounted a carbide holder having an outlet, the generator being connected with a gas tank in which a gas-bell is mounted free to slide. Close to the outlet mentioned a shutter is mounted and able to swing freely, thus being adapted to control the flow of carbide through the outlet. A pair of link devices in the generator which are jointed together at their lower ends have their upper ends connected to the shutter so as to swing the same. A lever is provided which has a slotted end

adjustably connected with the gas bell and controlled thereby, and this lever is connected to the upper end of the two link devices by another link, this latter link swinging on the upper end of the two link devices during the movement of the gas-bell and lever after the shutter has reached the end of its swinging movement.

No. 1,007,909—To Joseph O. Angermeier, Inglesfield, Ind. Granted November 7, 1911; filed April 15, 1910.

**LIFTING JACK**—In which a piston is lifted by means of a fluid under pressure.

2. This jack is a combination of a lower chambered member with a vertical cylinder containing a piston on which a prop is seated. The prop is normally held yieldingly in an upright position, but may be swung down when required. Means are provided to center the lower end of the prop on the piston and for admitting an actuating fluid into the chamber below the piston.

No. 1,008,138—To George C. Hale, Kansas City, Mo. Granted November 7, 1911; filed June 3, 1911.

**CLUTCH**—Being of the cone type.

This clutch comprises a drive-shaft to which is secured a clutch member provided with a rim carrying studs. The stem of the shaft carries a spring seat. The driven clutch member has a sleeve and is mounted on the drive-shaft stem; its rim carries pins. A spring surrounds the drive-shaft stem between the driven member and the spring seat. The sleeve mentioned is encircled by a collar having radial arms provided with perforations which receive the pins on the rim of the driven clutch member. Means are provided for shifting the collar so as to engage the radial arms with or disengage them from the studs on the rim of the clutch member of the drive shaft.

No. 1,007,977—To Earle T. Robinson, St. Louis, Mo. Granted November 7, 1911; filed October 22, 1910.

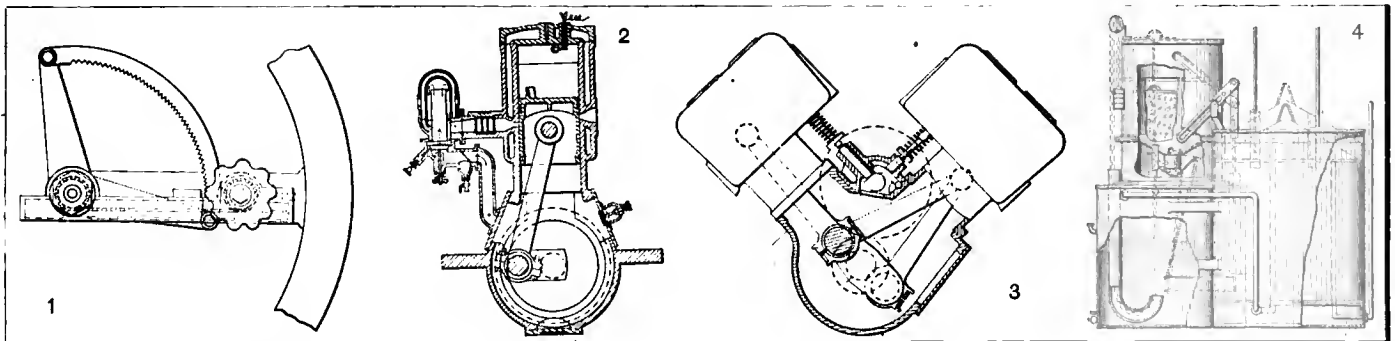

Fig. 1—Coffin steering mechanism. Fig. 2—Riegels' liquid fuel engine. Fig. 3—Belknap-Swartz motor. Fig. 4—Angermeier acetylene generator

# Newest Ideas Among the Accessories

## Turner Gasoline Torches

**B**LOW torches, as illustrated in Figs. 1 and 2, are used to produce such hot gasoline-air flames as are of use in brazing, tempering, annealing and melting work, not forgetting welding and soldering jobs. The apparatuses here

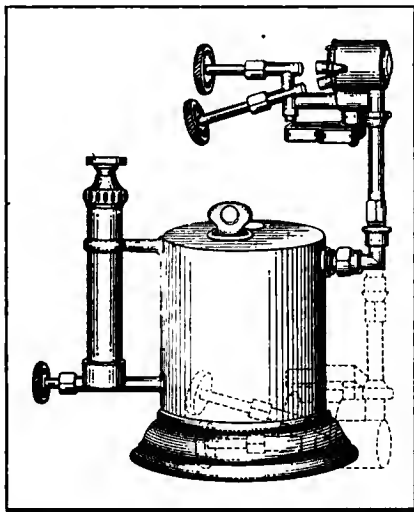

Fig. 1—Blow torch designed for use of gasoline

shown are made by the Turner Brass Works, Sycamore, Ill. The devices consist of seamless steel tanks, into which a sufficient quantity of the fuel is filled. Then the space above the level of the liquid is filled with compressed air by either working the pump attached to the

smaller types of torch, or connecting the air inlet of the tank with a source of compressed air. After the pressure of the air inside the tank has reached a sufficiently high degree, as indicated by the gauge accompanying the torch, the air inlet valve is closed, and the apparatus is ready for operation.

If the outlet of the tank is opened by means of the proper valve, the gasoline or kerosene used as fuel is pushed out of the tank at a high rate of speed and if lighted provides a hot flame. The machine shown in Fig. 1 is intended for the use of gasoline only, and a double jet is used in it for producing the very high temperature required for the work. It is claimed that this type of torch will do the work of a common blowtorch in half the time consumed by the latter.

In Fig. 2 is illustrated the Turner hot-blast brazing machine No. 68A, which is built for the use of either gasoline or kerosene. The principle of construction and operation of this machine are identical with those of the smaller type, to which it is very much superior, however, as far as capacity is concerned. The large size may burn at full blast for 5 hours, without pausing or refilling. One feature distinguishing it from the smaller machine is the use of two burners connected to the tank by oiltight, copper-covered tubing attached to two valves on the top of the tank. Either valve may be used independently or in unison with the other, giving one or two very hot flames.

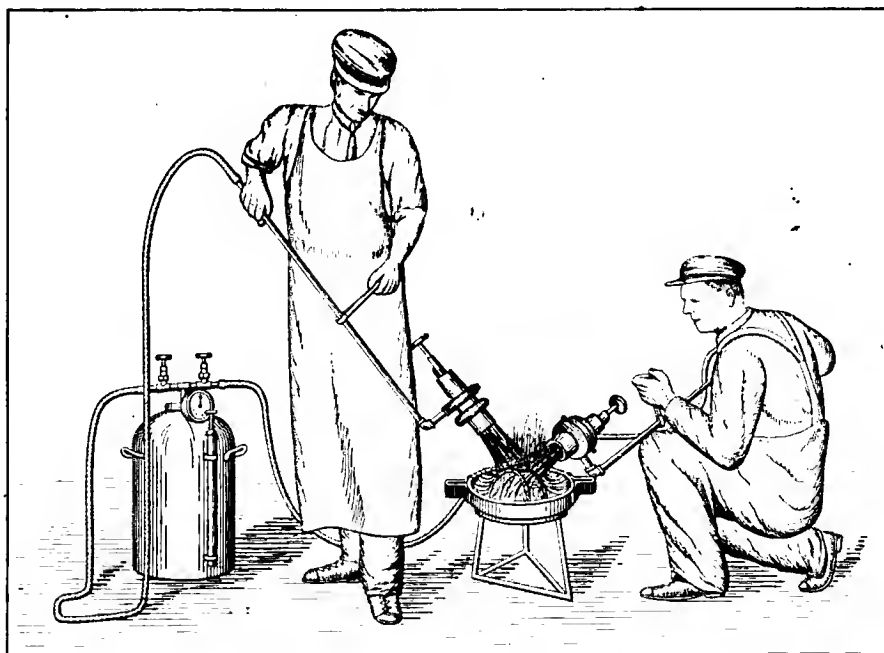

Fig. 2—Turner hot-blast brazing machine in which either gasoline or kerosene is used

## Langrehr Safety Device

The Langrehr explosion-safe fuel receptacle shown in Fig. 3 is constructed with the object of protecting gasoline or similarly combustible fuels in a can from spontaneous combustion which might arise by the admittance of a flame into the in-



Fig. 3—Langrehr safety fuel receptacle

ner space of the receptacle. Broadly speaking, the principle of the Davy lamp has been utilized in this device, but has undergone considerable modifications, before it was found available for efficient service. In the Davy lamp a wire-mesh screen is used to separate the flame from the explosive gases which otherwise would have free access to it. Should such gases enter the lamp through the screen and ignite, they will be prevented from firing back out of the lamp space by the cooling effect of the wire-gauze screen.

In the Langrehr device the number of openings in the partition between flame and fuel is reduced, thus impeding the progress of the flame to a much higher extent than a wire screen; the increased metal surface provides an augmented cooling effect.

As Fig. 3 shows, the Langrehr device consists of a series of corrugated and smooth strips of metal of suitable strength and elasticity, forming passages. The metal strips series are rolled in tube shape. By the use of a tube of suitable length, the total free cross section of the passages is almost equal in area to the aperture of the vessel, to which the tube is connected.

The massive metal strips forming the passages cool the burning gases, if such should enter the tube, to such an extent that it is impossible for the flame to reach the interior of the vessel in which the combustible substance is contained.

The American representative of the German inventor of this device is Dr. Edward D. Feldman, Berlin Chemical Laboratories, 560 West 171st street, New York City.

# THE AUTOMOBILE

## Technical Notes on Olympia Show

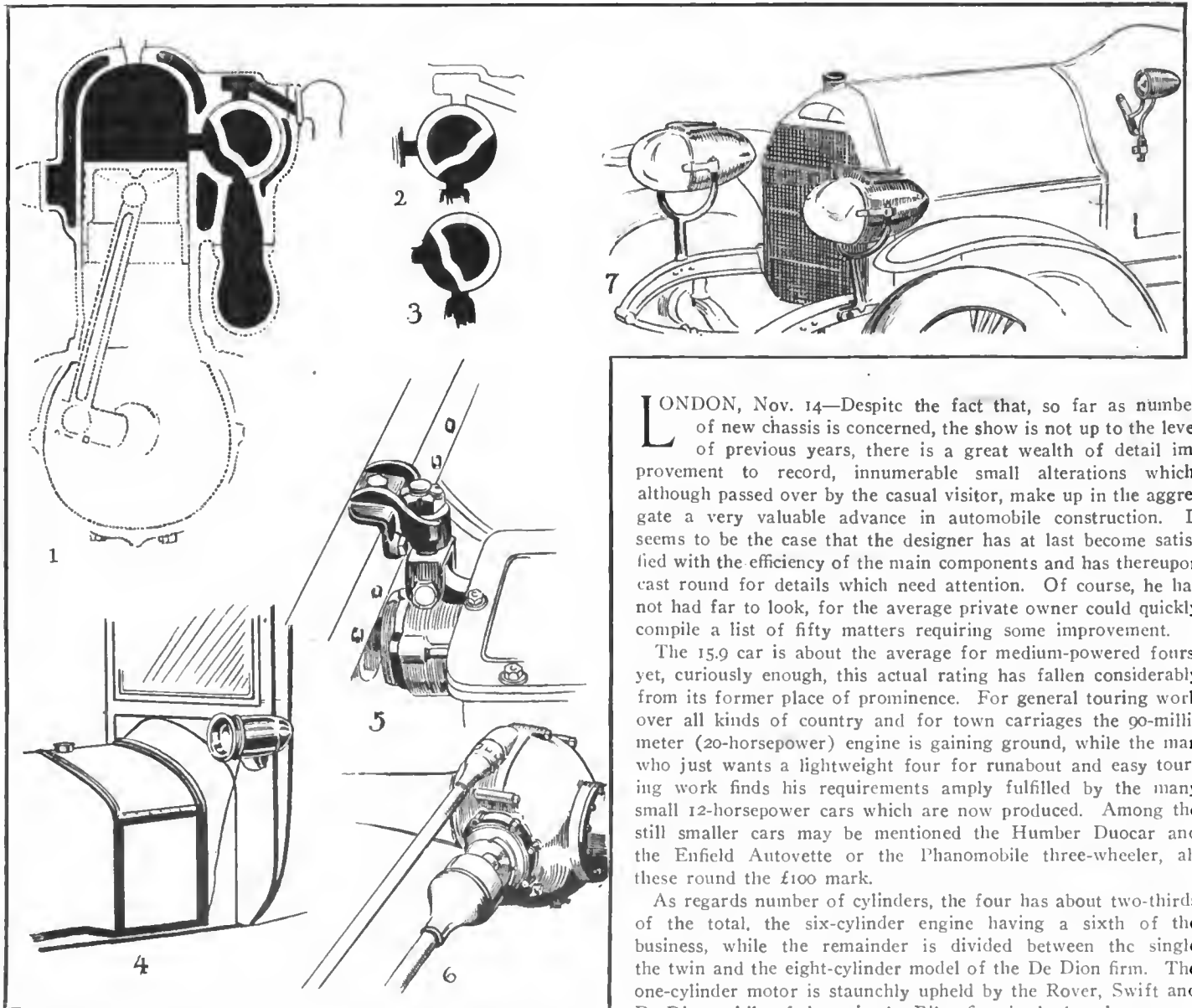

Illustrating the cycle of the Darracq valveless motor—1, the exhaust stroke; 2, at the end of the suction stroke; 3, the compression stroke  
 4—The new limousine of the Sizaire-Naudin has inside control and novel disposition of the gasoline tank in front of the dash  
 5—Showing an ingenious method of supporting the gearset on the cross-member of the frame, as adopted in the Sunbeam  
 6—Detail of the rear suspension of the Delahaye car which shows new position of torsion bar  
 7—Some novelties in the shape and arrangement of the head and sidelights seen on the new Daimler

LONDON, Nov. 14—Despite the fact that, so far as number of new chassis is concerned, the show is not up to the level of previous years, there is a great wealth of detail improvement to record, innumerable small alterations which, although passed over by the casual visitor, make up in the aggregate a very valuable advance in automobile construction. It seems to be the case that the designer has at last become satisfied with the efficiency of the main components and has thereupon cast round for details which need attention. Of course, he has not had far to look, for the average private owner could quickly compile a list of fifty matters requiring some improvement.

The 15.9 car is about the average for medium-powered fours, yet, curiously enough, this actual rating has fallen considerably from its former place of prominence. For general touring work over all kinds of country and for town carriages the 90-millimeter (20-horsepower) engine is gaining ground, while the man who just wants a lightweight four for runabout and easy touring work finds his requirements amply fulfilled by the many small 12-horsepower cars which are now produced. Among the still smaller cars may be mentioned the Humber Duocar and the Enfield Autovette or the Phanomobile three-wheeler, all these round the £100 mark.

As regards number of cylinders, the four has about two-thirds of the total, the six-cylinder engine having a sixth of the business, while the remainder is divided between the single twin and the eight-cylinder model of the De Dion firm. The one-cylinder motor is staunchly upheld by the Rover, Swift and De Dion, while of the twin the Riley firm is the best known exponent. The single and the twin engine has each its own class of followers, and one cannot foresee the likelihood of either type going out of fashion.

The valve controversy has broken out more fiercely than ever; in fact, the situation is almost as exciting as when, in 1908, the Knight engine was presented to the British public by the Daimler company. The two intervening exhibitions have seen no further

complication of the issue, though, of course, new licenses of the sleeve-valve engine have made their bow each year. But now the whole of the industry seems likely to be drawn into the struggle, for new claimants for public favor are to be found in the Argyll firm, with its single-sleeve engine; in the Darracq rotary valve motor and in the piston valve design of the Itala concern. And, meanwhile, we have the Crowdy piston valve engine as another competitor. Incidentally, it is announced that Messrs. Knight and Holbourne, after inspecting the new Argyll sleeve-valve engine and taking advice about the patents, deem the Argyll company to be infringing the Knight patents. This news has astonished the motor trade in Great Britain, because it suggests that Mr. Knight must be claiming a master patent over moving cylinder walls. But for that basic resemblance the Argyll and Knight motors seem quite distinct. Meantime the Argyll company is indemnifying all purchasers of its single-sleeve

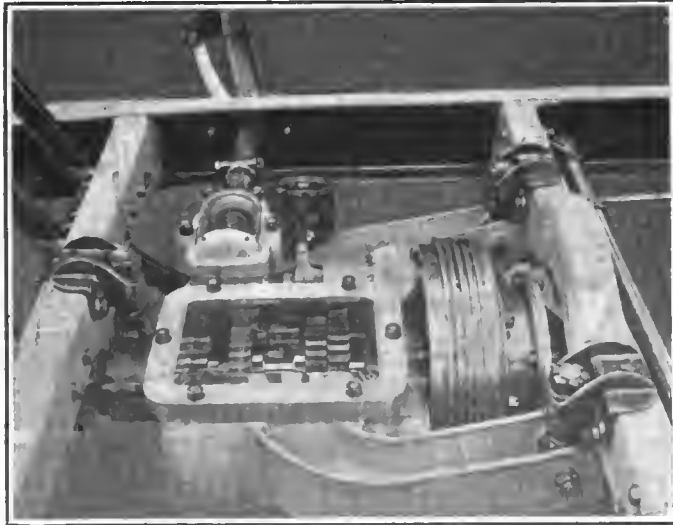

Sunbeam gearset, showing method of attaching to frame cross member

valve engines against penalty for infringement of patent, and the Piccard-Pictet firm, of Switzerland, which is using the Argyll patent, is following the example.

On the side of the Knight army, additional strength has been acquired by the arrival of two new Deasy models, by the new small Panhard (which means that the French concern is going to concentrate on the sleeve-valve engine) and by the adoption of the engine by the Stoeber company.

#### Monobloc Construction Favored

With regard to the technical details of the engines at the show, it is clear, in the first place, that single-cylinder castings are not favored, save by Austin and one or two other firms. Parr castings are general except for engines under 15 horsepower, where the monobloc construction is a strong rival. For six-cylinder engines two pairs of three cylinders each form the usual practice. Daimler and Napier are two exceptions; the former engines have the exhaust branches coupled up in two threes so that two consecutive firing cylinders never exhaust into the same branch. The V arrangement of cylinders is found in the Riley, the Delahaye (a six-cylinder) and the eight-cylinder De Dion. About the only example of desaxé placing of the cylinders is afforded by the two new Rover models.

The average ratio of stroke to bore shows a distinct increase. As the top limit there is the Sizaire 15, with stroke of 170 for a 70-millimeter bore, while the only engine with bore greater than stroke is to be found on the N. E. C. stand. The two Lan- chester models, four and six cylinders, have equal bore and stroke of 4 inches, and the Opel 12 supplies a case of the stroke being shortened this year from 120 to 100 millimeters; otherwise the tendency is toward bigger crankshaft throws. Examples of long-stroke engines are the Sunbeam, 90 by 160, and the La Buire, 80 by 160.

Chain-driven crankshafts are all the rage. For this, at least, one

must credit the Knight-Daimler engines. Probably over two-thirds of all the engines in the show are thus equipped. Of the others the Spyker and the Fiat 15 horsepower have worm-driven shafts. Overhead camshafts are employed in the engines of the Maudslay and Germain firms, though rumor has it that the latter engines will soon be valveless.

The above practice has silence of running as its object; smoothness of running is now better insured by the balancing of flywheels—a patent, but generally unsuspected, cause of vibration. As for the periodic vibration of crankshafts, the previous existence of this trouble is evident from the importance of the firms which now employ vibration dampers. Rolls-Royce, Daimler and Deasy are three examples.

Ignition shows improvement in regard to the use of self-advancing magnetos, while a novelty which looks like having a future before it is the Simms arrangement of combined ignition and lighting dynamo. A similar dual service is rendered by the Ford flywheel magneto.

#### Some Additional Refinements Noticed

Other engine tendencies are revealed by the increased adoption of thermo-syphon circulation (Vauxhall has reverted to the pump, however) by the reduction in the number of external water pipes (compressed rubber rings being used between adjacent cylinder cases) and by the remarkable increase in the employment of proprietary carbureters.

The engine is always regarded as the life of the car; hence we have dealt with it here at some length. For the transmission details a shorter notice must suffice. New types of clutches are to be seen in the Vauxhall disc arrangement, which has powdered graphite as the lubricant, in the Panhard cast iron and fiber disc clutch, and in the leather and oil conc clutch of the new Humber models. A variation of the latter is provided by the Rolls-Royce and Crossley designs, wherein a few drops of oil are injected into the clutch from the engine supply each time the pedal is depressed.

A radical departure from previous practice in gearbox construction is evidenced by the B. S. A. arrangement of combined rear axle and speed gearbox, a design also used by the Sheffield

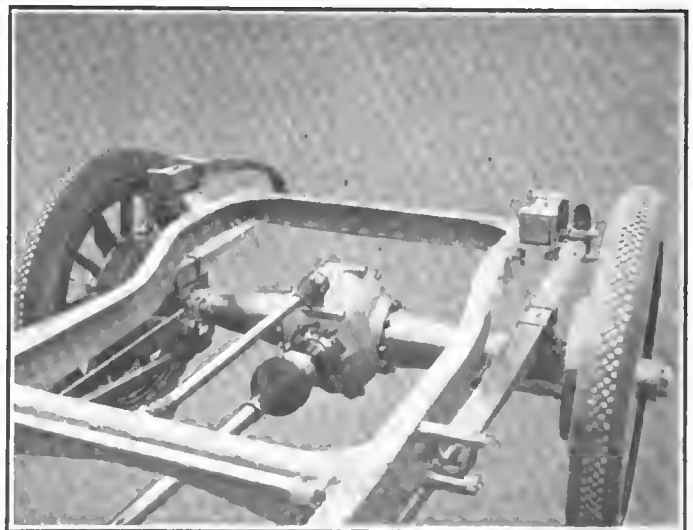

Rear suspension of the 1912 Delahaye

Simplex firm. This method offers distinct advantages in the way of simplicity and also in regard to silence of the indirect gears, and it is by no means unlikely that the custom will have a considerable vogue in the future. In gearboxes of the standard type the layshaft is often placed below the main shaft, particularly in those boxes designed for the use of oil as the lubricant. The Maudslay chain-driven gear box is an example of a novel but highly satisfactory design, while epicyclic gearing is still retained by Lanchester. All Talbot gear boxes have a sprag device, a once universal fitting.

Despite the announcement by a few firms (notably Sunbeam

and Crowdy) that they intended to abandon worm gearing for bevel, the former method of rear axle drive increases in popularity, Minerva and the Humber being two prominent accessions to the now lengthy list. In the Thorneycroft, Star and Straker Squire lists one worm-driven model (for closed carriages) is included. The Armstrong Whitworth rear axle has spiral gear drive, while another novelty in this chassis component is found in the direct drive on the third and fourth speed provided on the 15-horsepower Lancia car.

It seems clear that eventually both brake sets will be placed at the road wheels. Front wheel braking is hardly popular as yet, but this practice will certainly come into general favor before long. Meantime many makers are placing both brake sets at the rear hubs, some, like Panhard's, favoring the expanding type for both, while others resemble the B. S. A. in the use of a double set of outside bands. A dozen cars have a combination of the two forms. Raybestos, or some similar lining, is becoming general, and hand adjustment may be described as almost essential. A point for criticism is the complication of the equalizing arrangements for the rear brakes; the Vauxhall suggests itself as a simple yet effective method.

#### Unit Construction with Three-Point Suspension

Great attention seems to have been paid to the springing. Not a few firms, such as Arrol-Johnson, Austin, Panhard, employ elliptics at the rear, while three-quarter elliptics are to be seen everywhere. Lever or other special suspension methods are common; three or four firms (Deasy and Rolls-Royce in the list) use the Lanchester type.

Adjustable steering columns and pedals indicate increased attention to the drivers' convenience, while the several additional cars fitted with engine starters show how this desirable accessory is gaining ground. Two other cars (Armstrong Whitworth and Picard Pictet) are provided with mechanical tire pumps—useful fittings, yet doubly so are the engine-starting apparatus also supplied. A number of makes are equipped with an electric light dynamo as part of the standard equipment—the Armstrong Whitworth's and the Daimler sixes suggest themselves. Going further than this, a dozen firms supply top, screen and head

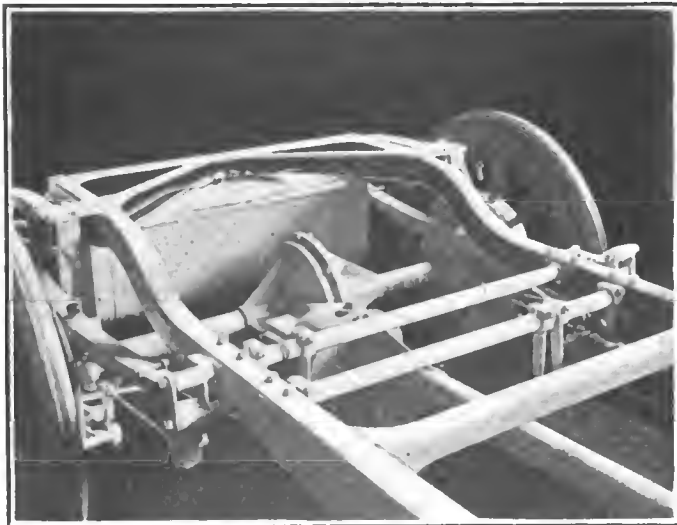

Rear suspension of the 1912 Lancia

lamps with their cars; by next Olympia we shall have arrived at that satisfactory state of affairs when every car is sold fully equipped and ready for full use, without any charge for extras.

Unit construction of motor, clutch and gearbox has been made a conspicuous feature on European cars for 1912. It is difficult to understand, in many cases, why the change has been made, for it has not tended toward accessibility, and to dismount any one of the three parts forming the unit is generally a workshop job. Three-point suspension usually goes hand in hand with unit construction, though there is really no general rule, some makers

adopting the unit type to give additional rigidity to the frame, and others to gain greater flexibility. In the former case the entire unit is bolted to the frame members, while in the latter the attachment is at three points only. It should be pointed out that this unit type of construction is being found to tend towards increased noise, a droning being set up when running fast, and this naturally being accentuated when running on one of the gears. So much importance is attached to silent operation that this tendency to hum may be a serious objection.

Panhard has set the fashion by producing the new 1912 model with the 15-horsepower Knight motor on the unit system with three-point suspension. Hangers to left and right of the motor base attach to the frame members, and the rear of the gearbox is bolted to a transverse frame member, the clutch housing and gearbox coming under the footboards in a manner which, externally at least, recalls Ford design.

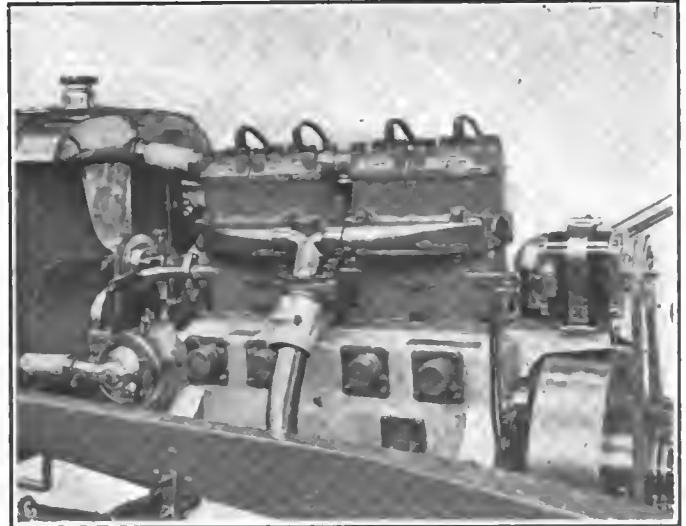

Carburetor side of Delaunay-Belleville motor

Another important example is to be found on the De Dion Bouton models. The existing types have not been changed, but where new models have been produced unit construction and three-point suspension have been adopted. There are two of these, both very small, low-powered cars intended for work as light runabouts. Hangers on the crankchamber attach the motor to the side members, and the rear of the gearbox is hung to a tubular cross member.

#### Fiat Offers Interesting Unit Design

A most interesting construction is to be found on a small Fiat car. The base of the crankchamber is in one casting with the complete gearbox. The base chamber itself adheres to standard lines of design, but instead of terminating at the rear with the upper portion of the crank chamber, it is flared out to form a skeleton around the flywheel and terminates in a complete gearbox. The upper portion of the crank chamber is quite orthodox, and although the cylinders are in one block with integral intake and exhaust manifolds, there is nothing startling in the design.

Lancia has an original production of a similar nature. A four-cylinder monobloc of 100 by 130 millimeter bore and stroke has the upper portion of its crankchamber and the entire gearbox in a single casting. Four hangers allow the motor base to be attached to the crankchamber, but from the rear pair of hangers the casting is continued into the gearbox, this latter having at its rear extremity two arms by which it is in turn secured to the side frames. Thus although it is a unit construction, its design further tends to stiffen the frame.

Crossley, of gas-engine fame, has a true unit construction with crankchamber forming one casting, and clutch housing and gearbox another, the two being bolted together. The entire power plant is carried on two tubular cross members, with a single point attachment at the front and two points at the rear.



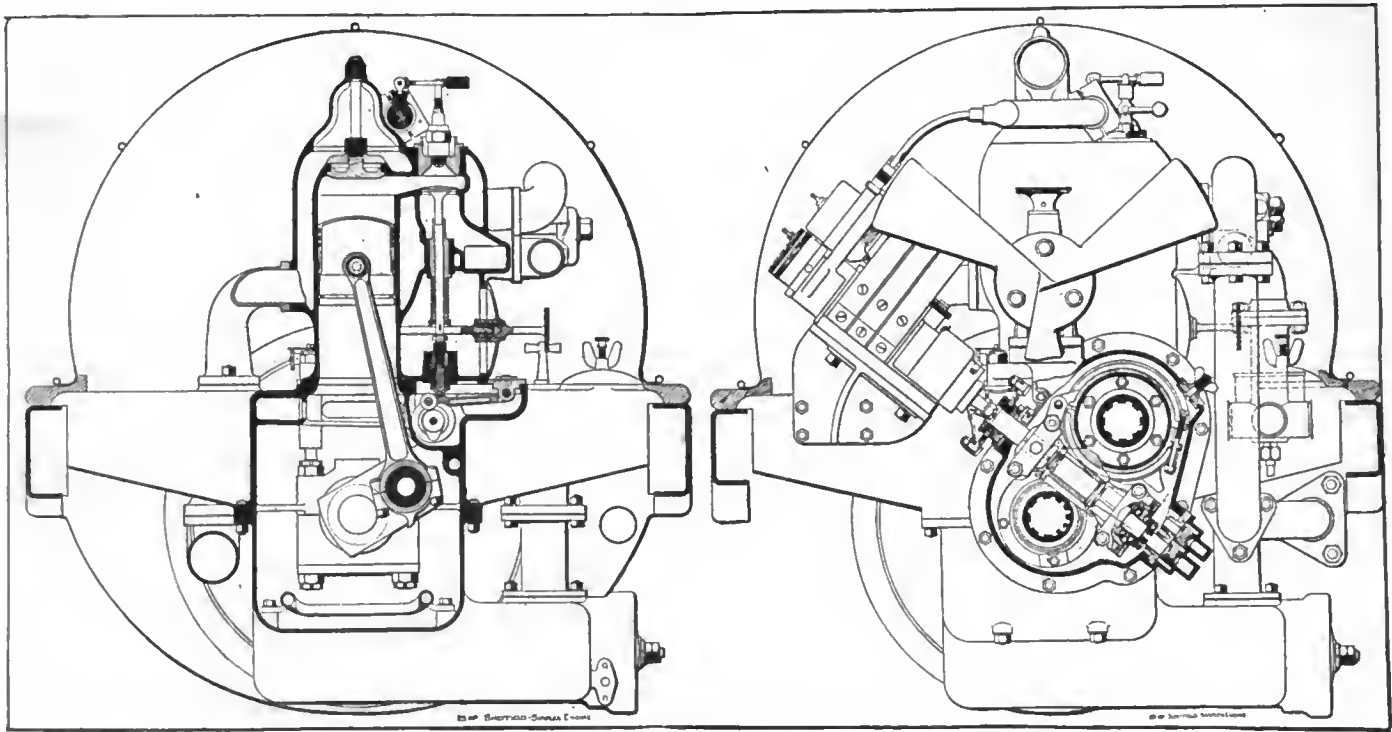

Transverse section and front view of the 25-horsepower Sheffield-Simplex motor

Three-bearing crankshafts for small motors—4-inch bore or less—is by far the most common method of construction. A large number of firms, indeed, carry their mainshaft on two bearings only, but it should be pointed out that several who were satisfied with two bearings last year have gone back to three bearings. The small Fiat, of 80 by 130 mm. bore and stroke, and the small Lancia have their crankshafts carried on two ball bearings. Delage employs a ball bearing for the center of the crankshaft of his six-cylinder motor, but has anti-friction for his two end bearings. The same maker has used five ball bearings for the crankshaft of his fast runabout. However, on his standard four-cylinder models this maker uses two bearing shafts. As a general rule the English makers are not in favor of two- or three-bearing crankshafts for respectively four- and six-cylinder motors. Thus, both Crossley and Sunbeam employ five bearings for the four-cylinder motors, and Sunbeam has seven bearings for the six-cylinder monobloc.

A silent chain in place of meshing pinions is very extensively employed on cars of both English and Continental construction. It is now used, for poppet valve motors, by Crossley, Sunbeam, Unic, Sizaire, Clement-Bayard, Chenard-Walker, Gregoire, Vauxhall, as well as by many others who adopted it a year ago. With the spread of monobloc casting for motors of larger and

larger size, there have been made improvements in the simplification of water, intake and exhaust piping. Lancia, Fiat and S. P. A., three of the leading Italian makes, are conspicuous in this respect by reason of intake and exhaust manifolds cast with the cylinders, and all piping abolished. In these cases the carburetor is bolted up direct to the intake manifold, the throttle being within the cylinder casting. On the Piccard-Pictet models there are separate exhaust manifolds for the two groups of cylinders, but the inner extremity of each passes into a common descending exhaust pipe.

#### Many Chain-Driven Cam and Magneto Shafts

Crossley, the Manchester builder, has stuck to the five-bearing crankshaft. Separate chains are used for camshaft and magneto shaft, the magneto being mounted on a bracket cast on the crank chamber and having a sliding bush so that the magneto and its shaft can be moved laterally. Lubrication is forced throughout, the arrangement made for indicating the level of oil in the base being by an inclined glass tube on the outside of the base of the crank chamber. Provision is made for lubricating the spigot end of the shaft. At the end of the crankshaft a valve closes the oil way bored through the shaft; when the clutch is withdrawn—it is inverted cone type—a trigger opens this valve and allows oil to flow along the spiral groove cut on the spigot. As in many other cases, Crossley drives his fan by belt from the magneto shaft.

Wolseley has adopted chain drive for the camshaft and magneto and pump shafts. Three-point suspension has been made use of for the gearbox, while the mud pan has been abolished.

Panhard's novelty is the new Knight motor of 80 by 130 mm. bore and stroke with three-point suspension, the crank chamber being attached by the two side arms, and the gear box being bolted at the rear to a transverse frame member. Three plain bearings are used for the crankshaft, with pressure feed lubrication to the main bearings and through the bored shaft to the connecting rod ends.

Delaunay-Belleville changes comprise the inclining of the valves in order to diminish the size of the combustion chamber. This has been done on all the models but a small four cylinder car. Gate change has had to be adopted to meet the requirements of the British market. An interesting feature is the new carburetor, which really consists of two carburetors combined,

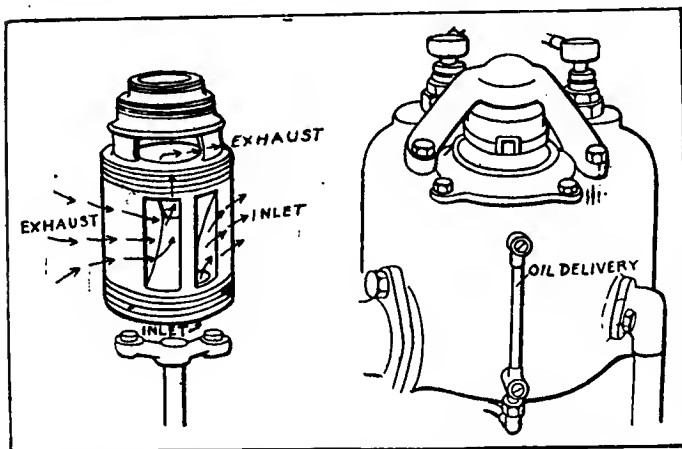

External view of Itala distributor valve and of the valve chamber

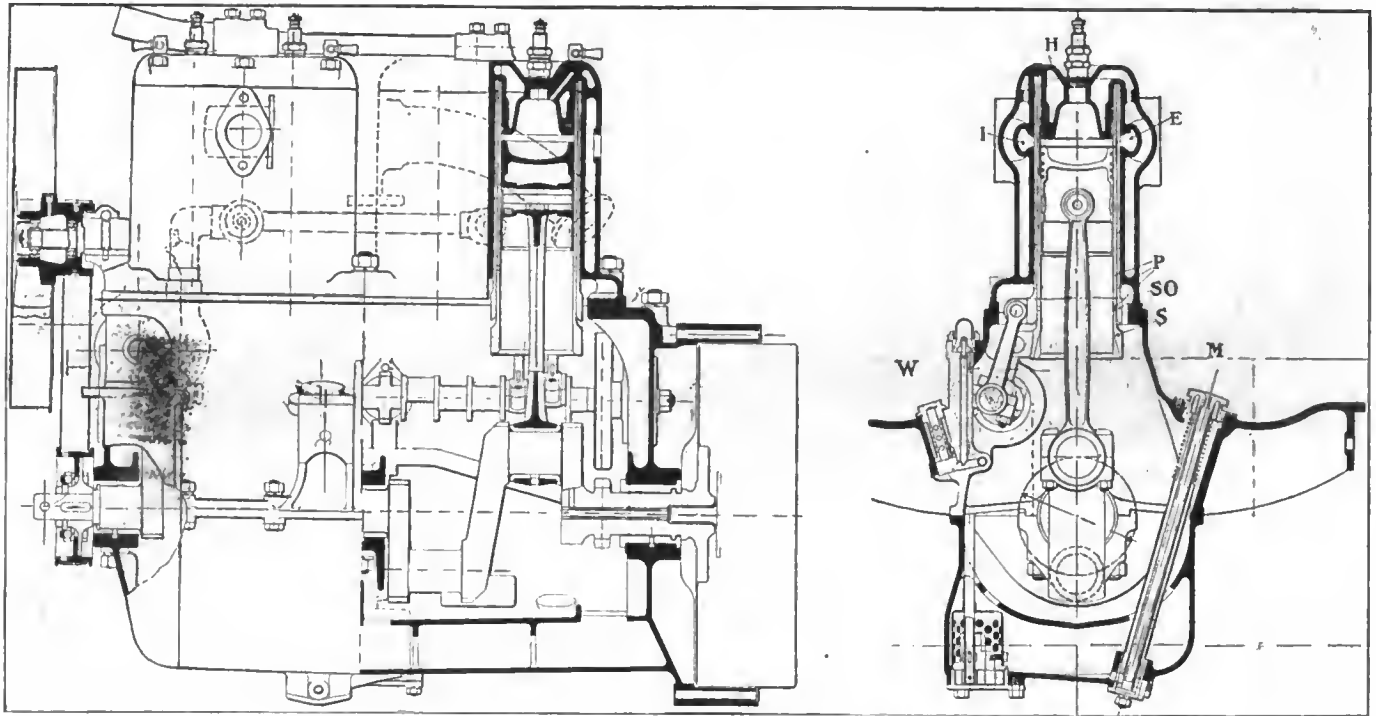

Side and transverse sectional views of the 15-horsepower Panhard-Knight motor

one being an ordinary single jet type with variable primary intake and additional air through a glycerine dashpot, and the other a surface carbureter, with the same level maintained as in the float chamber, and used for slow running and starting.

**The Rotary Valve Itala Motor**

An examination of the new valve gear introduced by the Itala Company, one of the famous Turin firms, shows the rotary valve therein adopted as something quite different from any of the other few types of rotary valves on the market. Only the 35 horsepower chassis has been fitted with this new device. The engine has four vertical cylinders, which are cast in pairs. The bore of the cylinders is 105 mm and the stroke 150 mm. The ordinary four inlet and exhaust valve spaces in the poppet valve type of engine are replaced by two spaces, each containing a rotating valve that carries out the functions of distribution.

This rotating valve is of the simple design and is connected by a vertical rod to one shaft that takes the place of the two camshafts. The function of this shaft is to drive the magneto and water pump, and to rotate the valves. This is done by means of an endless screw of the same type as the well-known Itala device, which for years has proved so efficient for driving the firing cams of the low tension ignition.

Each rotating valve exercises the same functions as two inlet and two exhaust valves. The ordinary water and oil circulations for cooling and lubricating the engine are extended to the rotary valve; and when it is remembered that the valve rotates only once to four revolutions of the engine, it can be seen that the chances of seizing are eliminated. Should, however, seizing take place through the unlikely event of both cooling and lubricating systems not functioning properly, a wedge inserted in the vertical rod which rotates the valve would act as a safety valve and sever the connection, and thus prevent any damage to the engine. In order to insure regular and even functioning of the rotary valve there are two compensating chambers in the wall of the valve cylinder so that all pressure on the rotary valve by the explosions is obviated. By the system of intake and exhaust, the only alternating moving parts in the whole engine are the pistons, and consequently this type of engine can be constructed to run at high speeds without provoking vibrations. As the rotating valve, which is on one side of the cylinders, rotates almost in contact with the combustion chamber (which is made perfectly semi-spherical), and there is no valve space on the other side of the cylinders, the efficiency of the engine in the production of power from a given cylinder volume has been found to be increased by about 30 per cent.

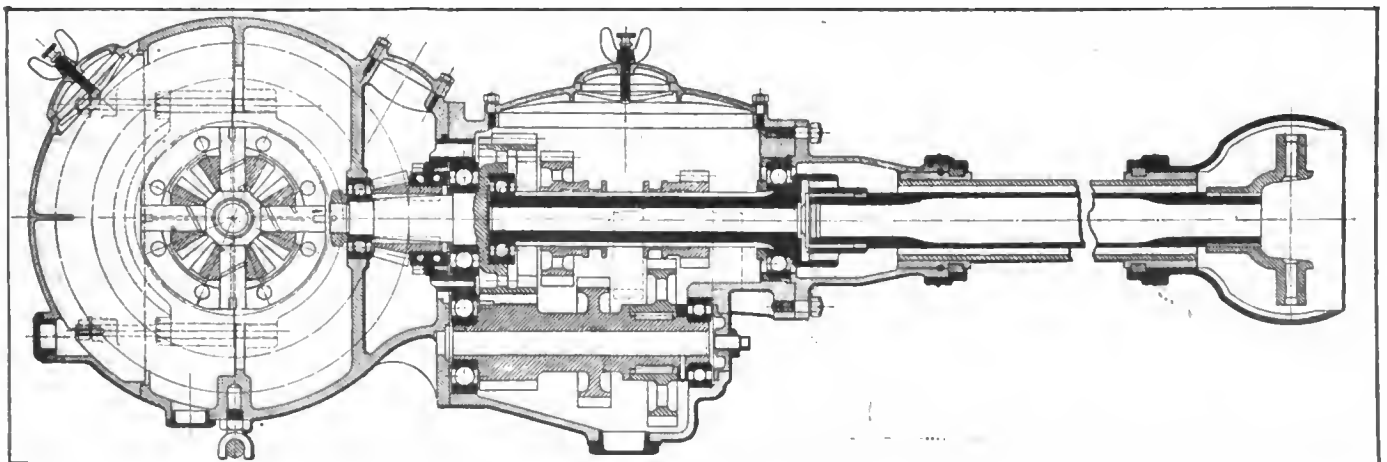

Longitudinal section Sheffield-Simplex 3-speed gearbox and rear axle

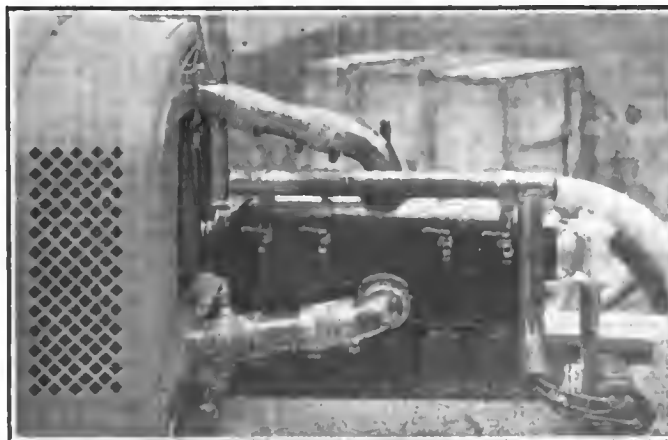

Darracq 20-horsepower valveless motor, showing magneto leads

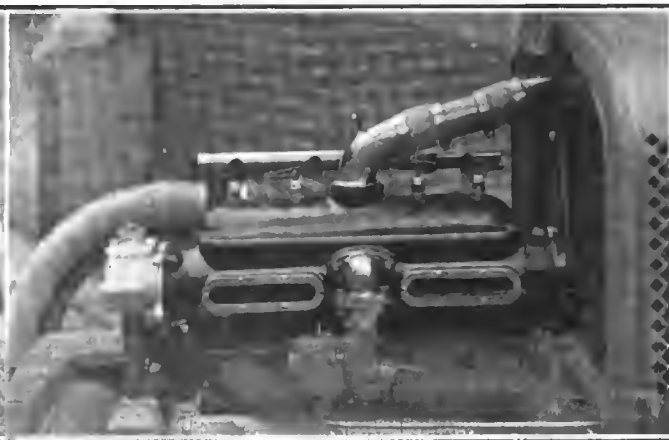

Distributor valve side of Darracq 20-horsepower valveless motor

### Few Cars, with Power Tire Pumps

One of the few cars shown with a power tire pump is the new six-cylinder Armstrong-Whitworth of 90 by 135 mm. bore and stroke. In addition to the pump, provision has been made for electric lighting by dynamo. On the valve side of the motor there is an auxiliary shaft driven off the enclosed timing gears and connected up to a lighting dynamo mounted on the bed plate of the motor. On this auxiliary shaft is carried a pinion transmitting power to a parallel shaft operating an air-cooled cylinder for pumping tires, there being a sliding pinion on the pump shaft which can be brought into engagement with the fixed pinion on the dynamo shaft.

Scat, Piccard-Pictet, and Adams are the only other firms fitting a tire power pump. The Piccard-Pictet case is particularly neat, the pump being a single vertical cylinder bolted to the top of the gearbox cover and having its piston worked off one of the constant meshing pinions. This pump has been employed for a couple of years on both the Piccard-Pictet and the Hispana-Suiza cars. Piccard-Pictet also shows a new rear axle in a one-piece forging, having very much in common with the axle shown by Renault a year ago. It is a one-piece production with the ends bored out to receive the drive shafts and the center forming a cradle for the differential, the front being closed by a steel plate, and the rear by an aluminum cover. A convenient fitting is a combined ignition switch and petrol cock on the dashboard. The gasoline is under pressure, the feed pipe passing across the front of the dash and the cock connected to the switch, so that when the ignition is off the gasoline flow is closed.

### Side Lights on the Henriot Motor

The Henriot rotary valve motor has four cylinders of 95 by 140 mm (3.7 by 5.5-inch) bore and stroke. On one side of the cylinder casting and near the head—in this case on the left-hand side—is a cylindrical chamber receiving the hollow rotary distributor. The rotary valve chamber has three sets of ports: in the head the intake ports giving communication with the intake manifold surrounding the chamber; below, in the same vertical plane, the exhaust ports admitting into the bolted-on exhaust manifold, and between the two the port communicating with the combustion chamber. The hollow rotary distributor has four roughly D-shaped sections to correspond with the ports for the four cylinders, and it is by reason of the flat portions of the roller that the opening into the cylinder can be put into communication with either the intake or the exhaust ports, while the circular portion of the roller shuts off all communication with the combustion chamber during compression and firing. The most important feature of this motor is that the ports are covered by the piston at the end of the compression and at the beginning of the firing strokes.

In order to allow the easy passage of the piston across the face of the ports, these latter are two in number and oblong

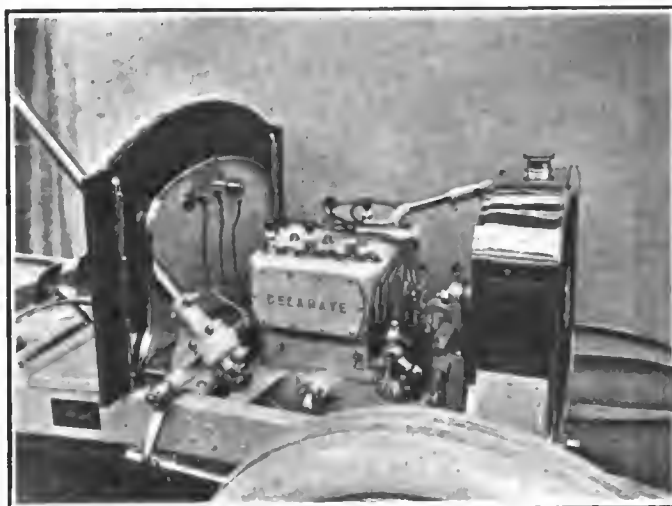

Delahaye six-cylinder monobloc V-type engine

shaped, the greatest dimension being in the direction of travel of the piston. The two ports in the distributor chamber are also oblong shaped, but with the greatest dimension in the opposite direction—from front to rear.

The motor is a bloc casting with the intake manifold cast with the cylinders, and with the distributor water-jacketed. Water circulation is by thermo-syphon with the inlet pipe connected up to the right-hand side of the motor and the outlet from the top of the casing to the dashboard radiator. The crankshaft is carried on three plain bearings, and the crankchamber is divided

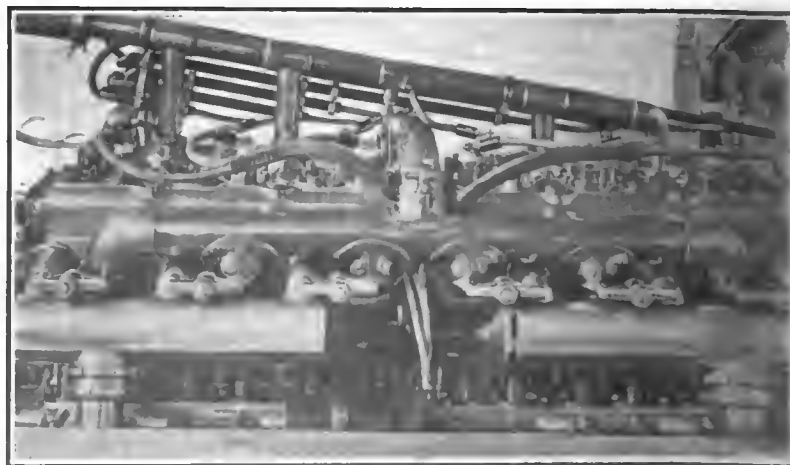

Left side of Rolls-Royce engine



Magneto side of Belsize 10-12 motor

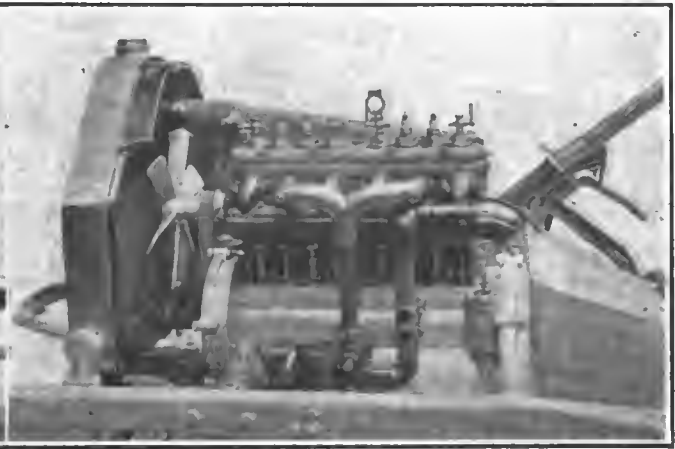

Valve side of Belsize 10-12 motor

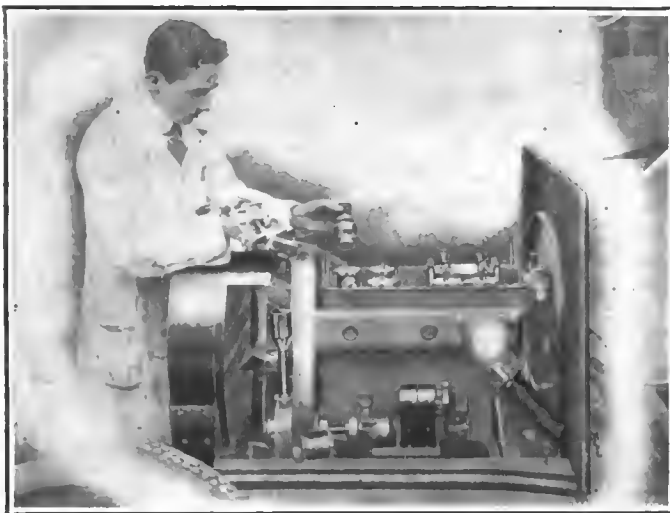

Showing easy removal of valves of Germain motor

into two chambers to secure the correct level of oil in each for splash lubrication. The lubricator is mounted high up on the dash and driven by belt from the rear of the distributor. What is generally known as the Renault type of bonnet has been adopted, but combined with it is a 10-gallon gasoline tank, and in the center of the dash the belt-driven mechanical lubricator already mentioned. There is no fan, and no vanes on the flywheel.

#### Innovations of the Rolls-Royce

Rolls-Royce, Ltd., exhibited three complete cars which, so far

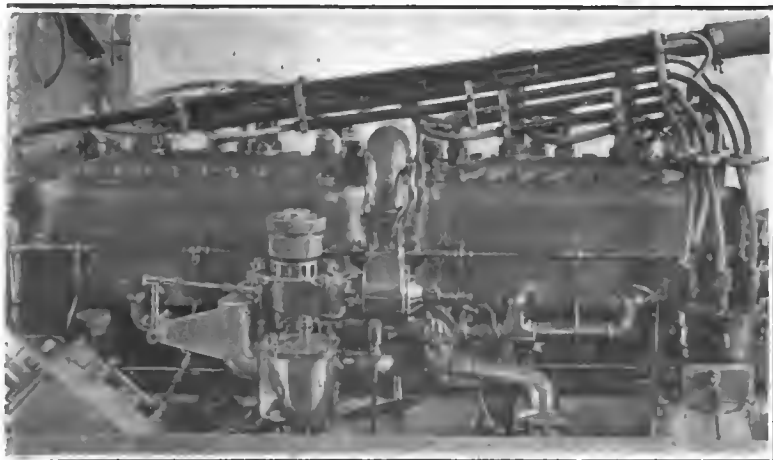

Right side of Rolls-Royce engine

as their outward appearance was concerned, showed no change from last year's models. A number of detailed improvements have been effected, however. Carburetion has been given special attention in the new models, and the flywheel and timing gears are so connected to their shafts that any slight vibration at certain motor speeds has been eliminated. Because no chassis was shown, it was impossible to get any detailed information as to the improvements which have been effected.

The 40-50-horsepower model has six cylinders, cast in blocks of three. The valves are all on one side and are operated by rocking levers. The motor, which has a seven-bearing crankshaft, is specially suspended by links. There appears to be little change in the design and arrangement of the power plant, though several refinements are evidenced. The three-speed drive is retained, which is contrary to the adoption by some of the other prominent makers of the four-speed type. One important innovation for 1912 is the adoption of a spherically ended torque tube which encloses the propeller shaft. The frame has been made more rigid also, by the addition of tubular cross-members throughout, with the exception of the rear tie-rod, which is of U-section.

#### Lancia Abandons Fan Belt-Drive

On a small four-cylinder monobloc Lancia, the designer has got away from the use of belt drive for the fan by fitting a water turbine within the fore end of the water jacket. The car being a new one, only just received from the factory, no detailed information could be furnished even by the agent; the external appearance, however, was remarkably neat, there being nothing outside to show how the fan was driven. Lubrication is under pressure to the two ball bearings in which the crankshaft is carried, and to the connecting rod ends, but no pump was visible; it was declared that the half time pinion acted as oil pump, but how the agent was unable or unwilling to say. On this car the four-speed gearbox is now carried on the rear axle, with all the gear shifting mechanism—selective type—passing inside the torque tube. The bigger car, four cylinders of 100 by 130 mm., was orthodox in the position of its gearbox, but original by being a one-piece casting with the motor base, two arms at the extreme rear of the box attaching it to the frame members.

To facilitate brake adjustment the Vulcan cars had an extension from the winged nut regulating the external shoes of the transmission brake, up to the side member of the frame; instead of having to stoop under the chassis to regulate these shoes, the work could be done from the side of the car.

#### Lanchester Cars Present Novel Features

Despite the fact that conservative design finds favor among English engineers, there is one British car which stands out distinctively—the Lanchester. There are many novel features possessed by the Lanchester—such as the wick carbureter, the

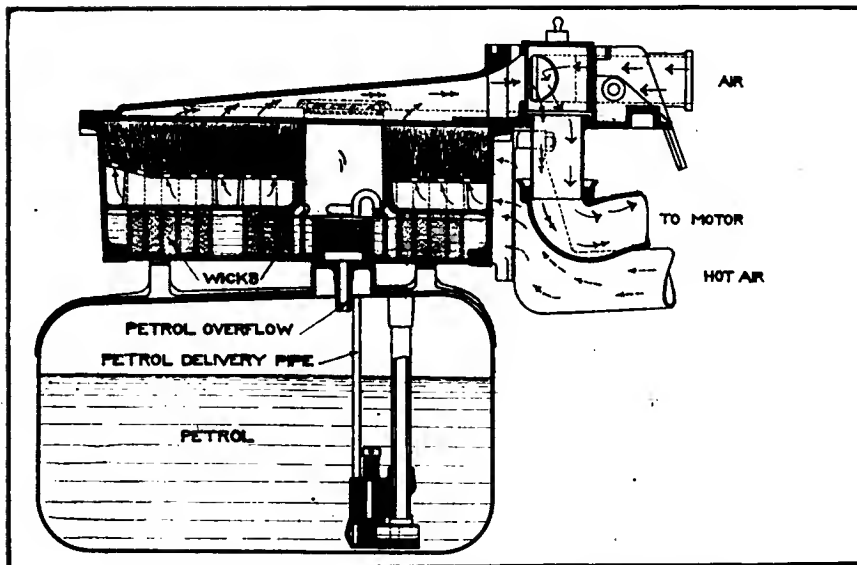

Wick carburetor, one of the novel features of the 1912 Lanchester line

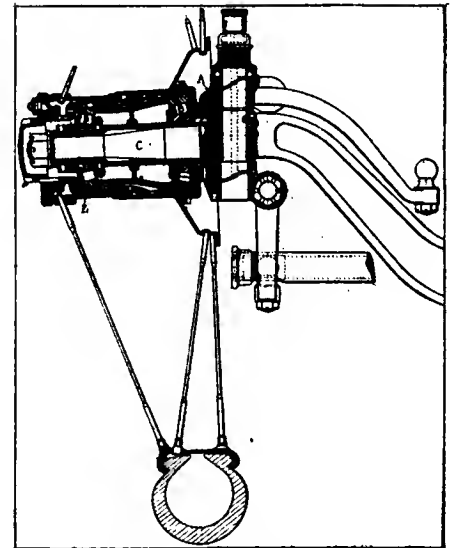

Showing details of Crossley front axle and steering knuckle

epicyclic gearing and principally in the absence of a front bonnet.

In 1912, two types of Lanchester cars will be constructed, the 25 four and the 38 six, both having pair-cast cylinders of 4-inch bore and stroke. This is about the only case of a "square" European engine; the 1912 average will be somewhere about a 1.6 ratio of stroke to bore.

Prominent features of the Lanchester motor are the horizontally placed valves in the heads, these valves being kept on their seatings by flat springs. On the "four," thermo-syphon cooling is quite satisfactory; the bigger six calls for a pump. High tension dual magneto and high pressure (30 pounds square inch) lubrication are employed. The main fuel tank forms one of the cross-members of the frame; from here the liquid is pumped up by the engine to the wick chamber, through which the in-rushing air is passed. Extra air is provided through an automatic valve, and the outfit is complete, save for an adjustment left to the driver to compensate for weather variations. By the fact that the supply of fuel pumped up to the wick-chamber varies directly with the engine speed, the strength of the mixture is always approximately constant.

The transmission system comprises a multiple disc clutch and three-speed epicyclic gearbox, the gear changes here being made by means of disc clutches, with a positive lock for the high. In the gearbox there is a force pump which supplies oil under pressure to all the bearings. Final transmission is by worm gearing, with the worm below the center.

The rear suspension is another novel point. Two long flat springs are attached to the frame sides and their rear ends are free to slide in block brackets on the axle casing. An arrangement of parallel and jointed radius rods keeps the axle in place.

#### Some Daimler Refinements of Detail

While Daimler, of Coventry, has made no great change in the Knight-engined models, there are a few interesting detail improvements. On the six-cylinder models provision is made for receiving a dynamo for electric lighting purposes. It is evident that this matter will receive more and more attention from car manufacturers, for the numerous electric lighting systems now on the market are meeting with a considerable amount of favor, but the great difficulty is that they cannot be neatly and conveniently fitted when produced as an afterthought. A change over has been made in the positions of the sliding and universal joints, the sliding joint now being at the rear of the propeller shaft, instead of at the fore end. Among the few changes in the motor is the attachment of the sliding oil troughs to the upper portion of the crank chamber, the lower portion thus acting as an oil retainer only. A patented vibration damper, con-

sisting of a light multiple disc slipping clutch, through which the fan is driven, is a new feature. The slip on the clutch at the commencement of the tremor is sufficient to rectify it before it has made itself conspicuously felt.

Among English makes the highest ratios of stroke to bore are to be found on Sunbeam cars, where dimensions are 80 by 150 for a four-cylinder, and 90 by 160 for both a four and a six-cylinder model. In view of the high reputation of Sunbeam for design, it is interesting to note that five bearings are used for the four-cylinder monobloc motor and seven bearings for the six-cylinder with its cylinders in two castings. The valves, all on one side, have their stems inclined with a view to reducing the area of the combustion chamber. This, as already mentioned, has also been adopted by Delaunay-Belleville. Webs between the hangers and at the front of the motor completely fill up the space between motor and frame.

#### Unit Construction Used in La Buire Cars

The novelty of the La Buire construction is the fitting of a foot and lever operated brake on an extension of the propeller shaft at the back of the axle. This firm has also made use of unit construction for all models and has some of the largest monobloc castings to be found in the show, a six-cylinder being 85 by 140 mm., and the biggest fours in one bloc being 90 by 160 and 105 by 150 mm. respectively. There is a special coupling on the tail shaft of these models, allowing them to be quickly disconnected from the propeller shaft, enabling the multiple disc clutch to be withdrawn in a single unit.

Self-starters do not appear to have been very seriously tackled by European makers, for the only new one is to be found on the Alldays car. It consists of a small air compressor driven by gearing from the chain-driven camshaft and compressing air into a tank. The compressed air is used to drive an oscillating pneumatic motor connected up by worm gearing to the clutch shaft, with an arrangement by which the clutch shaft can over-run the shaft of the pneumatic motor. Compressed air and other types of self starters were brought out in Europe four years ago, but owing to their complications never really caught on. Where they are most desired is on small cars driven by their owners, and it is here that complication is least needed.

#### Vauxhall Typical British Poppet Valve Car

• Two types of the Vauxhall car are made, the 20 and 30 horsepower, with four- and six-cylinder engines respectively. The casting of the 30-horsepower cylinders in threes is the method followed by the majority of British constructors. No case exists of the use of single-cylinder units for a six. The bore and



stroke dimensions are 90 mm and 120 mm respectively, this ratio being somewhat less than the average. Special pains have been taken to secure minimum weight for the reciprocating parts. The sides of the cast-iron piston are drilled out, while the connecting rods are drilled away till the finished article looks quite fragile, but no case is reported of failure at this point. The result of the weight-cutting is apparent in the increased speed of rotation—very little vibration being observable at high speeds.

It will be noted that the valves are all on one side and that the tappets are cased in by removable plates. All clearances in the valve mechanism are cut down, six-thousandths being the gauge limit between tappet and valve. The valve camshaft, the magneto shaft, and even the fan spindle, are all driven by means of silent chains. Thus there is no gear wheel inside the engine save the internal magneto distributor wheels.

In the transmission system, a multiple disc clutch, with 45 flat plates of phosphor bronze and mild steel, takes the power to the four-speed gearbox. In the Vauxhall the top gear is the direct drive. The gearbox is quite ordinary, shortness of the shaft being obtained by the now general practice of sliding the third speed gear inside the constant-mesh wheel to give fourth speed. The locking of the gear which is in use is made by spring plungers placed in the top of the case; the change speed lever and gate are quite free of all adornment, a noteworthy point being, however, that the transverse change-gear rod is provided with a double universal joint to compensate for any frame flexure on rough roads. The rear axle is bevel driven, rather the exception than the rule in these days of worm drive. To take up the drive a deep pressed steel girder is provided as a torque stay.

Both sets of brakes are internal expanding, the shoes being lined with copper and the drums provided with heat-dissipating flanges. The foot-operated brake is placed behind the gearbox.

#### As to Meeting American Competition

Very few attempts also appear to have been made by European manufacturers to meet American competition in the cheap car line. In most cases it is declared that quality will win out, and that in a couple of years the demand for American cars will have ceased. Beloise is about the only maker having seriously tackled the problem, the result being a complete two-seater with hood, windscreen and lamps selling at \$1,100. The motor is a four-cylinder of 69 by 130 mm. bore and stroke with unit construction, its general design being European throughout. Another example is the B. S. A. car with a four-cylinder Knight motor. The power plant, which is 75 by 114 mm. bore and stroke has been built by the Daimler Company and has really nothing distinguishing it from other models. The chassis, produced at the Birmingham Small Arms factory, is a direct copy of a well-known American car, with the difference that the three-speed gearbox is incorporated with the rear axle, and has its gears operated on the selective principle. As a complete two-seater it is being sold at \$1,550, a price which is much higher than the Beloise and greater than many American cars now on the European market.

#### Résumé of the Prospects for 1912

The British Industry has the immense advantage of being united in a self-governing body—the Society of Motor Manufacturers and Traders—and therefore, it is a simple matter for a generally expressed wish to pass gradually into law. Hence, next year may see the abandonment of the system whereby cars are labeled by their year of origin.

The past year has been extremely successful on the whole. A few concerns have not found orders rise to the high water level of the previous year; in these cases, it is evident that the popular taste has not been accurately gauged. The majority of the manufacturing firms report that business has shown an appreciable and welcome advance on the last report.

The state of trade may be fairly well judged by reference to the cheap car trade. The class "below \$1,600" has received

very meager attention from the high-grade British maker; it would be correct to say that it has been almost entirely ignored. But it has always been clear that this section offered a very extensive field of business, in which largeness of output would compensate for smaller margin of profits; and the manufacturers have not been blind to the fact. Therefore, it has been an open secret that the leaders have designed and constructed cars which may be classed as 12 horsepower, four-cycle, four seaters at \$1,200.

It is sufficiently clear, however, that these cars are not going to figure on the 1912 programs. The state of trade is taken to indicate that enough business will be available in the above \$2,000 class to keep the factories running, and meanwhile the smaller man can wait another year.

This is just where the American maker will probably score. The smaller man is quite tired of waiting; the various American cars now on the British market have sufficiently well demonstrated their good points to have overcome the former inherent prejudice, and reasonable success lies clear ahead.

At present, there are a dozen American makes available for the British buyer; some, as the White, Cadillac and Ford, have been on the market for years; others, as exemplified by the E-M-F, Flanders, Hudson, Brush, are of more recent introduction. Anyway, no matter what make be selected, the general reports agree that the cars have given reasonable satisfaction to their purchasers—more than this, they have proved themselves capable of better average performances than British cars of equal power but higher price. The anti-American car prejudice is now almost completely lived down. Next year should therefore prove successful to the American agencies in Great Britain.

To return to the British makers, it seems that the average power, in place of being reduced, will show an appreciable increase next year. This is due to the introduction of 20-horsepower models (with the corresponding 30-horsepower six-cylinder car) by firms which have previously concentrated on, among other types, the immensely popular 15.9 (80 millimeter bore). This car has proved highly efficient; the result has been that it is always overloaded and worked to death.

The average buyer is too unintelligent to be trusted with a light and efficient production; he keeps the engine extended to its limit all the day and wrecks it within a year. Hence the return to 20 horsepower (90 millimeter bore) for average touring and for small covered body cars. The smaller 15.9 will still be popular, but buyers will be strictly cautioned as to its limitations.

Increased attention is being paid each year to the design and quality of the coach work. The work turned out by the leading car firms is lighter in weight and better in quality than from the best of the old established coach builders, and almost all buyers now purchase the car complete. This is quite a change from a few years ago, when about half of the manufacturers' output consisted of chassis; upon which bodies were fitted by other firms.

#### Outstanding Features of Olympia Show

Four new sleeve or slide-valve motors; Darracq with single rotary distributor; Argyll and Piccard-Pictet with single sleeve; Itala with rotary distributor on vertical axis, one distributor operating two cylinders.

Increased use of the Knight motor.

Increase of bloc castings. Practically all four-cylinder motors up to 4 inches bore in one casting; a number of sixes in a single casting; intake and exhaust manifolds generally cast with cylinders; webs between crankcase hangers allowing mud pan to be abolished.

Unit construction of motor, clutch and gearbox, generally with three-point suspension. Where unit construction is not adopted three-point suspension is generally used for motor or gearbox or both.

Chain-driven cam and magneto shafts on a very large number of models.

Lengthening of piston stroke, the average ratio to bore on medium-sized motors being 1.63 to 1. A few as high as 2 to 1.

# Speed Practice Opens for Forty-Two

SAVANNAH, GA., Nov. 20 (Special telegram)—Jay McNay, driver of a Case car, was killed to-day in the first official practice and his mechanic, M. F. Maxwell, was seriously hurt. Maxwell is now in the local hospital. Joe Dawson, driver of one of the Marmons, also lies in the hospital. He was hurt in a collision while trying to avoid hitting a touring car. The accident to McNay has saddened the practice now being held. Maxwell, his mechanic, who was able to talk this afternoon, states the reason for the accident: "Just before arriving at the cattle-park the flagman gave us the clear flag, and of course we put on more speed. Just then we saw a wagon in the road, and, as McNay swung to one side, the car skidded into a tree." McNay's chest was crushed by the steering wheel. Death was instantaneous. Maxwell has his arm broken in three places, his left side bruised and his face lacerated.

The accident to Dawson was unusual. He was riding as mechanic for Joe Nikrent and had just changed seats with him. Approaching Bethesda on Whitefield avenue the road is a little narrow and here they met a touring car. Nikrent took the side of the road with too much speed and Dawson was thrown out. He was unconscious until he arrived at the hospital.

Knipper, in a Mercer, was following close behind Dawson and Nikrent. He set his brakes and came to a sudden stop. Barnes, following in a second Mercer, failed to see Knipper when he made his sudden stop and the two went together. Both cars

were badly broken up but none of the occupants was hurt. De Palma, who made the two fastest laps in the Grand Prix in 1908, drove one lap at the rate of 75.9 miles an hour in his Mercedes. Of the smaller cars, the Mercer driven by Barnes made the fastest time—66 miles an hour. Summary:

Car	Driver	Lap time			Fastest time M.P.H.
Fiat	Bragg	15:50.	15:09.1	23:49.3	67.5
Fiat	Matson	20:17.2	36:17.	14:38.2	70
		15:09.2	16:15.1		
Benz	Bergdoll	15:41.3	13:47.4	13:54.1	74.8
Benz	Hearne	15:30.	13:47.	19:14.2	75
Fiat	Wagner	14:31.4			70.7
Benz	Hemery	13:48.3	15:04.		73.9
Mercedes	Wishart	16:39.3	15:10.3	33:43.3	67.2
Fiat	Parker	13:57.3	15:50.3	17:20.4	75.8
		15:45.2			65.1
Pope-Hartford	Disbrow	14:07.1	15:02.1		72.3
Lozier	Grant	17:41.4	13:40.2	15:27.3	75.9
Mercedes	De Palma	33:02.4			31
Lozier	Mulford	15:25			65.8
Case	Disbrow	15:35			66
Mercer	Barnes	16:40			
Mercer	Hughes				

Jay McNay, Case; Mortimer Roberts, Abbott-Detroit; Witt, E-M-F and Evans, E-M-F, were out, but did not make complete rounds of the course from the grandstand.

## Records Still Further Lowered on Second Day

SAVANNAH, GA., Nov. 21 (Special Telegram)—To-day's practice brought out more records as far as speed for one round is concerned. David Bruce-Brown, the New Yorker, who

### VANDERBILT CUP—17 LAPS—291.38 MILES

Car.	Driver.	Model.	Number Cylinders.	Bore, Inches.	Stroke, Inches.	Displace- ment, Cubic Inches.	Horse- power.	Cylinder Type.	Lubrication	Ignition.	Clutch.
Mercer.....	Hughie Hughes.....	1912	6	4.365	5.0	448.5	45	T-head	Splash	Bosch	Disc
Lozier.....	Harry Grant.....	1912	4	5.375	6.0	544.6	46	T-head	Splash	Bosch	Disc
Lozier.....	Ralph Mulford.....	1912	4	5.375	6.0	544.6	46	T-head	Splash	Bosch	Disc
Mercedes.....	S. Wishart.....	1911	4	5.10	7.1	579.0	90	T-head	Pump	Bosch	Cone
Abbott-Detroit.....	L. A. Mitchell.....	1912	4	4.50	5.5	349.9	44	T-head	Pump	Bosch	Dry Plate
Abbott-Detroit.....	Carl Limberg.....	1912	4	4.50	5.5	349.9	44	T-head	Pump	Bosch	Dry Plate
Fiat.....	D. Bruce-Brown.....	1911	4	5.00	7.48	588.0	70	T-head	Pump	Bosch	Disc
Fiat.....	E. H. Parker.....	1911	4	5.00	7.48	588.0	70	T-head	Pump	Bosch	Disc
Fiat.....	Joe Matson.....	1911	4	5.00	7.48	588.0	70	T-head	Pump	Bosch	Disc
Jackson.....	Harry Cobe.....	1911	4	5.00	5.5	431.9	60	Valve	Splash	Splitdorf	Disc
Marmon.....	Joe Dawson.....	1911	4	4.75	7.0	496.2	36	T-head	Splash	Bosch	Disc
Marmon.....	Bob Burman.....	1911	4	4.75	7.0	496.2	36	T-head	Splash	Bosch	Disc
Mercedes.....	R. De Palma.....	1911	4	5.1	7.1	579.0	90	T-head	Pump	Bosch	Cone
Pope-Hartford.....	L. A. Disbrow.....	1912	4	5.50	6.0	570.2	50	T-head	Splash	Bosch	Cone.

### SAVANNAH CHALLENGE TROPHY—13 LAPS—222.82 MILES

Case.....	T. D. McNay.....	1912	4	4.38	5.0	300.7	30	L-head	Pump	Bosch	Disc
Case.....	W. P. Barnes, Jr.....	1911	4	4.38	5.0	300.7	30	L-head	Pump	Splitdorf	Disc
Mercer.....	Hughie Hughes.....	1911	4	4.38	5.0	300.7	30	T-head	Splash	Bosch	Disc
Mercer.....	Billy Knipper.....	1911	4	4.38	5.0	300.7	30	T-head	Splash	Bosch	Disc
Marmon.....	C. Patschke.....	1911	4	4.37	5.0	299.0	32	T-head	Splash	Bosch	Disc
Marmon.....	Joe Nikrent.....	1911	4	4.37	5.0	299.0	32	T-head	Splash	Bosch	Disc
Ohio.....	McFarlane.....	1912	4	4.50	4.75	302.2	40	T-head	Pump	Splitdorf	Disc



Bruce-Brown, last year's Grand Prix winner, being timed in a fast practice trial over the Savannah course in his Fiat car

# Cars Entered in Savannah Road Races

won the Grand Prix last year, traveled over the course at the rate of 80 miles an hour. This is the road record here. Not a single accident marred the practice. Summary:

Car	Driver	Lap time	Fastest time
Fiat	Bruce-Brown	13:40. 12:57.6 14:18.	M.P.H. 80
		14:15. 14:30.8	
Fiat	Matson	13:30. 13:26.4	77.4
Fiat	Bragg	15:18.8	68.6
Mercedes	Wishart	14:38.6 13:27.6 13:29.8 13:32.6	77.3
Mercedes	De Palma	15:04.8 32:34.2 35:02	68.4
Lozier	Grant	14:23. 14:17	72.9
Lozier	Mulford	13:45.2 22:38.6 17:38.8	76
Benz	Bergdoll	13:45	76.2
Pope Hummer	Diabrow	15:30 13:43	76.3
Mercer	Hughes	15:47. 13:36.2 15:20	77
Abbott-Detroit	Mitchell	16:26.4	63.3

Under the present plan the course will be open to the exclusive use of the drivers in each of the classes at specified times. The small cars will be allowed to practice at speed for 1 hour before noon each day, while the Vanderbilt Cup cars and Grand Prize contestants will come on the scene later in the day.

The Savannah Challenge trophy and Tiedeman Cup races will be called at 7 o'clock next Monday morning. The first event is thirteen laps of the 17.14-mile course, or 222.82 miles. The Tiedeman is ten laps of the circuit, or 171.4 miles. The two races will be run together. It has been estimated that the speed achieved in the Savannah Cup race will approximate 62 or 63 miles an hour. If that proves to be accurate, the race will be

finished at about 11 o'clock. Several of the contesting cars named in this event have shown speed in excess of the figures given.

The difference in mileage between the Savannah and Tiedeman races will probably cause the smaller cars to complete their race considerably before the Savannah cars finish.

It is planned to start the Vanderbilt Cup race about 11.30 o'clock. This race consists of seventeen laps of the course or 291.38 miles. If a speed a trifle in excess of 70 miles an hour is made, the race will be over at 3.30.

It is quite likely that the Grand Prize cars will be sent away early in the morning of Thanksgiving Day. The exact hour has not been fixed for the start, but it will surely be before 8 o'clock. The distance of the Grand Prize race is twenty-four laps of the course or 411.36. Traveling at the rate of 75 miles an hour the winner cannot finish the distance under 5.15. If the start is at 8 o'clock, this would bring the finish to 1.15 p. m.

The Marmon drivers seem to have a strenuous time ahead of them as Dawson and Patschke are scheduled to start with a pair of small cars in the Savannah Challenge Cup race at 7 o'clock Monday morning. As soon as this contest is finished the pair will assume the handling of two big Marmons in the Vanderbilt Cup race and on Thursday both will drive in the Grand Prize. Hughes, captain of the Mercer team will have his hands

## GRAND PRIZE—24 LAPS—411.36 MILES—NO LIMIT TO DISPLACEMENT

Car.	Driver.	Model.	Number Cylinders.	Bore, Inches.	Horse-power.	Cylinder Type.	Lubrication.	Ignition.	Clutch.
Abbott-Detroit	C. A. Timberg	1912	4	4.50	44	L-head	Pump	Bosch	Dry Plate
Abbott-Detroit	L. A. Mitchell	1912	4	4.50	44	L-head	Pump	Bosch	Dry Plate
Benz	Erwin Bergdoll	1912	4	6.10	120	Valve	Splash	Bosch	Cone
Benz	Victor Hemery	1907	4	6.10	120	Valve	Splash	Bosch	Cone
Benz	Eddie Hearne	1912	4	6.10	120	Valve	Splash	Bosch	Cone
Lozier	Ralph Mulford	1911	4	5.38	46	T-head	Splash	Bosch	Disc
Fiat	D. Bruce-Brown	1912	4	5.91	90	T-head	Pump	Bosch	Disc
Fiat	C. S. Bragg	1912	4	5.91	90	T-head	Pump	Bosch	Disc
Fiat	Louis Wagner	1912	4	5.91	90	T-head	Pump	Bosch	Disc
Marmon	C. Patschke	1912	4	4.75	36	T-head	Splash	Bosch	Disc
Marmon	Joe Dawson	1912	4	4.75	36	T-head	Splash	Bosch	Disc
Pope-Hartford	L. A. Diabrow	1912	4	5.50	50	T-head	Splash	Bosch	Cone
Bulck	Harry Cobe	1912	4	6.00	100	Valve	Splash	Bosch	Cone
Bulck	Chas. Basle	1912	4	6.00	100	Valve	Splash	Bosch	Cone

## TIEDEMAN TROPHY—10 LAPS—171.4 MILES

Car.	Driver.	Model.	Number Cylinders.	Bore, Inches.	Stroke, Inches.	Displacement, Cubic Inches.	Horse-power.	Cylinder Type.	Lubrication.	Ignition.	Clutch.
Abbott-Detroit	M. Roberts	1912	4	4.13	4.25	227.2	44	L-head	Pump	Bosch	Dry Plate
Abbott-Detroit	H. L. Hartman	1912	4	4.13	4.25	227.2	44	L-head	Pump	Bosch	Dry Plate
E. M. P.	Frank Witt	1912	4	4.0	4.5	226.2	30	L-head	Splash	Splitdorf	Cone
E. M. P.	Robert Evans	1912	4	4.0	4.5	226.2	30	L-head	Splash	Splitdorf	Cone
E. M. P.	Jack Tower	1912	4	4.0	4.5	226.2	30	L-head	Splash	Splitdorf	Cone
Ford	Kulick	1912	4	3.75	4	176.7	22.5	L-head	Splash	Ford	Disc

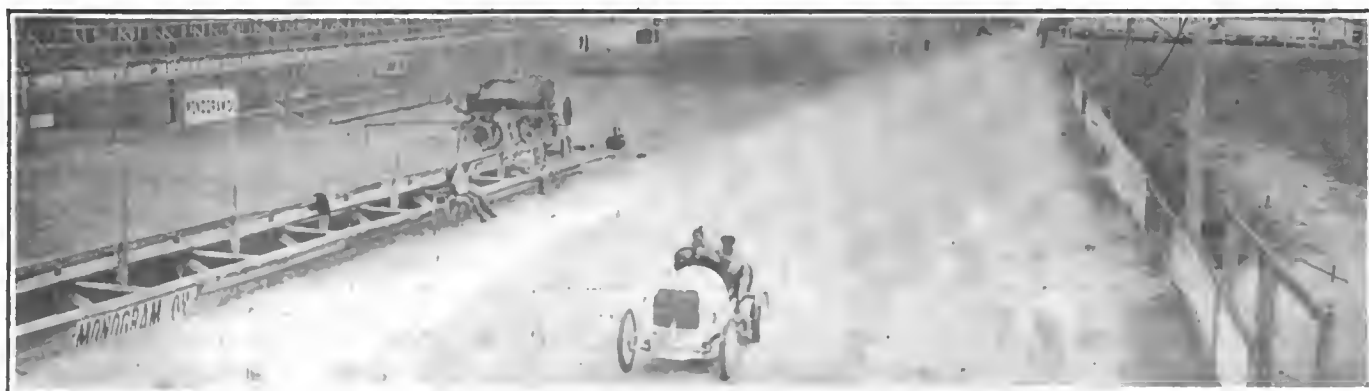

View of the upper end of the stretch, showing grand stand and pits—Hearne in Benz finishing his fast practice lap



Where the Lozier team is camping during practice week

full on Monday when he is scheduled to drive a small car in the Savannah and the new Mercer six-cylinder car in the Vanderbilt.

Bruce-Brown will drive a Fiat in both Vanderbilt Cup and Grand Prize races; Mulford will drive a Lozier in both; Limberg and Mitchell will handle Abbott-Detroits in both big events; Disbrow will drive the Pope Special in both. Harry Cobe is the only driver who will handle two cars of different makes at the meeting, driving a Buick in the Grand Prize and a Jackson in the Vanderbilt. All the other pilots have but a single mount.

The fields, from present indications, will not be large. The total official entry list for the four events to date comprises only forty-two cars, a reduction of twelve from the estimated entry list of last week. The box is still open and other entries may be made officially until Wednesday midnight, but it has been unofficially announced that if anyone wants to go in any of the races he can make legal entry on Friday.

Referee Morell made a circuit of the course this morning and pronounced it better than ever before as the result of the radical improvement upon it in preparation for the races.

On Saturday night a meeting of the drivers and mechanics was held at which preliminary instructions to cover practice were given out.

It is believed that the plan adopted to run the light car races before the Vanderbilt Cup will result in better time in each of the three races. In such contests the presence of mixed classes always has a tendency to develop slower time, particularly in passing on the turns. If all the cars engaged have approximately equal maximum speed, there is less likelihood of delays. The effect will be not only to make the races faster, but it is expected to make them safer as well.

The reason underlying the action of the committee in separating the light classes from the Vanderbilt was the well-known ability of some of the drivers engaged in these contests to make the slower car win. This of course may be accomplished legitimately by good jockeying in case the contest developed a tight fit. If a car, slightly slower than a rival automobile, is in the lead and the pilot drives desperately upon approaching a turn, it may be possible for him to get away so far that the pursuing car not catch him until the next turn, where the process may be repeated. In this way a narrow margin of advantage may prove enough to win or gain prominent place for a car that is not quite equal in speed to some of the others that finish behind it.

Another reason for this action, and the one that is most generally emphasized, is that drivers engaged to drive in the light car events and the Vanderbilt Cup, could not do so if the races were run coincidentally. The city is rapidly filling up with visitors and big crowds are out to witness the speed practice each morning. A rule has been promulgated barring women from

the racing cars in practice and prohibiting drivers from moving in the reverse direction of the course.

In the Grand Prix there is no limit to the piston displacement. The Vanderbilt Cup, however, provides for a piston displacement of 301 to 450 cubic inches; the Savannah Challenge Trophy for cars of 231-300 inches piston displacement, and the Tiedeman Trophy for cars of 161 to 230 cubic inches displacement inclusive.

Of the forty-two cars entered there are fourteen machines in the Grand Prize, the same number in the Vanderbilt; six in the Tiedeman Trophy and eight in the Savannah Challenge Trophy event.

Over \$20,000 has been spent on the course and over \$5,000 on the home-stretch alone. All turns have been banked and the course widened to 40 and 50 feet. At other places the course has been cut through a forest, thereby cutting out several bad turns



Dawson in the Marmon—hurt during a morning tryout

which bothered the big cars very much last year. The home stretch is almost like a boulevard, especially that section between Dale avenue and Waters road which was unbanked last year, and until passing the general admission grand stand, a quarter of a mile from the turn. The course has been widened here to over 40 feet.

New arrangements have been made to enable spectators to get to the grand stand. Instead of having to walk from the car line for a quarter of a mile, a new belt line has been built up to the stand on which cars will be run every 30 seconds.

The course will be guarded by the militia of Savannah. Around the stand and in the city limits the police will look after things.

The prices this year are: For the grandstand \$3 for two days; for the admission stand, \$1 each day. Boxes for two days, \$50 and parking spaces, \$25. Because of the unexpected rush for boxes, ten additional ones had to be made. The grandstand has been improved by boarding up the back. Last year the wind blew under it and made it very disagreeable for the spectators. The press stand and official judges' stand have all been repaired and are now in first-class condition.

#### Prize List Largest in the Country

The prizes this year are probably larger than any ever offered for racing events in this country. All told, there is over \$30,000 to be given the winners of first, second and third places in the four events. The cash offer of *The Savannah Automobile* of \$12,500 will be divided for the four events, while the Rayfield Carbureter Company has offered \$2,500; the Remy Magneto Company, \$4,250, and the Bosch Magneto Company, \$1,400. The Monogram Oil Company and other manufacturers have announced that they will give prizes if their goods are used on the winning machine. The cash prizes will no doubt run as high as \$40,000 before the races are over.

A prominent Savannah man, who gave \$1,000 last year for

the first American car finishing the race, has announced that he will give \$1,000 this year, but this time it must be an American car winning the race and not the first one to finish.

A large canvas tent will be placed in the Park Extension, the soldiers' parade-ground to accommodate the many cars that will be here during the week.

The hotels are rapidly filling up but still have rooms left. The homes of the people in the city have been thrown open just as was done last year and room for over 30,000 visitors is available.

During the days when there will be no racing a football game between Georgia Tech. and Auburn will take place. There will also be an aviation meet, with several of Curtiss' best men. Those in charge of this event are trying to get up a match between one of the aircraft and a Benz or Fiat racing machine.

### Racing Circuit Planned in Middle West

SIoux CITY, Nov. 20—At a meeting of the Sioux City Automobile Club last week it was decided to push all improvements on the new speedway to be constructed here and have them completed by July 1. The committee was instructed to obtain estimates on grading for a saucer-shaped mile track, on an 8-foot grade and on a 12-foot grade, and also for an oblong track with grades on the curves of 8 feet and 12 feet. Among other improvements a club house will be built at the speedway.

George O. Jamesson resigned as president of the club as he moved to Des Moines to take the State agency for the Apperson and Reo automobiles. C. S. Douglas of the Nebraska Buick Automobile Company was elected to succeed him. F. H. Reid was elected secretary to fill a vacancy caused by the resignation of C. S. Douglas.

H. B. Groves becomes the manager of the Interstate Auto & Supply Company which position Mr. Jamesson held.

There is some talk here of promoting a circuit of automobile



Visitors at the Benz camp at a farmhouse alongside the course

races taking in Omaha, Lincoln, Sioux Falls and Sioux City.

Omaha, Sioux Falls and Sioux City held successful race meets during the past season and are improving their speedways, and it is thought that if the four cities mentioned should go into a circuit the manufacturers would send some of the fastest cars in the country to participate in the races.

### Jersey Motorists Join for Good Law

New Jersey automobilists are now a unit in favor of a new, moderate, sensible automobile law. The recent election changed the complexion of the legislature of New Jersey to such an extent that much hope for better things is springing up in the hearts of the automobile fraternity.

As an indication of concerted action and solid ranks among

the motorists the fact has become known that the New Jersey Automobile and Motor Club, the large organization that split away from the American Automobile Association and the Associated Automobile Club of New Jersey last year, has made advances to the Associated Clubs and the New Jersey Automobile Trade Association to join hands with it in drafting a new automobile law for presentation to the coming session of the legislature.

With this idea in view the New Jersey club, the Associated Clubs and the Trade Association have formed a committee of fifteen, five from each organization, and empowered the committee to act. The committee has been instructed to draw up a bill repealing the noxious power-of-attorney clause in the present law, by which visiting automobilists are obliged to sign instruments empowering the Secretary of State of New Jersey to accept service for them in case of alleged infringements of the Motor Vehicle law. The bill will also be framed to provide for a reasonable exemption of visiting automobilists.

The measure advocated by the trade body and the association of clubs, which was built on the lines suggested above, was defeated by a single vote in the upper house after being passed by the assembly. The composition of the Senate remains almost the same as it was before, but the Assembly has been radically changed.

### Legal Matters That Interest Motordom

Three legal matters of importance to the automobile industry are being considered in the courts at New York at this time. Another preliminary injunction has been granted by the federal court in one of the Weed chain cases. This is similar to a host of other proceedings based upon the same subject matter. The defendant in this case was the Seneca Chain Company.

The second matter is the pendency of the decision of Judge Hazel in the suit of the Republic Rubber Company vs. Morgan and Wright, involving an alleged infringement of the knobby tread patent. The third interesting case is the suit of Fletcher R. Williams vs. the Lozier Motor Company, based upon an alleged agreement to sell the control of that company. This matter will be heard by Justice Seabury in part 1 of the Supreme Court on Thursday.

### Delaware Club Holds Annual Banquet

WILMINGTON, DEL., Nov. 20—The annual banquet of the Delaware Automobile Association, which was held Friday night at the Clayton House, in this city, was a notable event. About 100 persons were present, mostly members, though there were a few guests, including Robert P. Hooper, president of A. A. A.; H. M. Rowe, president of the Maryland Automobile Association, and Powell Evans, president of the Automobile Club of Philadelphia.

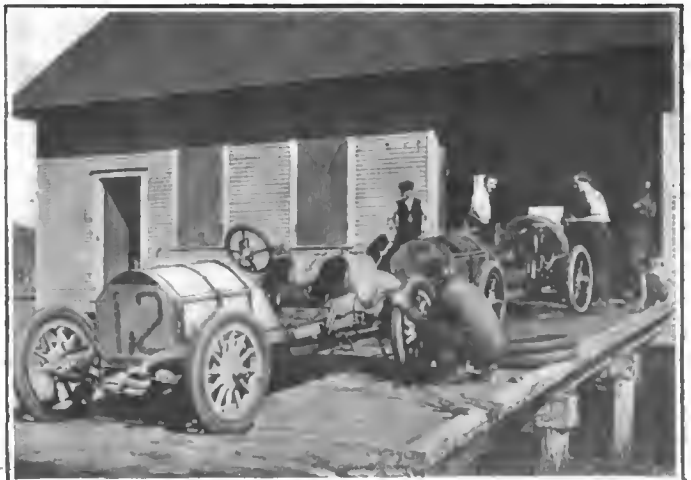

The tuning-up process at the Mercer camp keeps all hands busy



# Automobile Metallurgy Made Easy

By E. F. LAKE

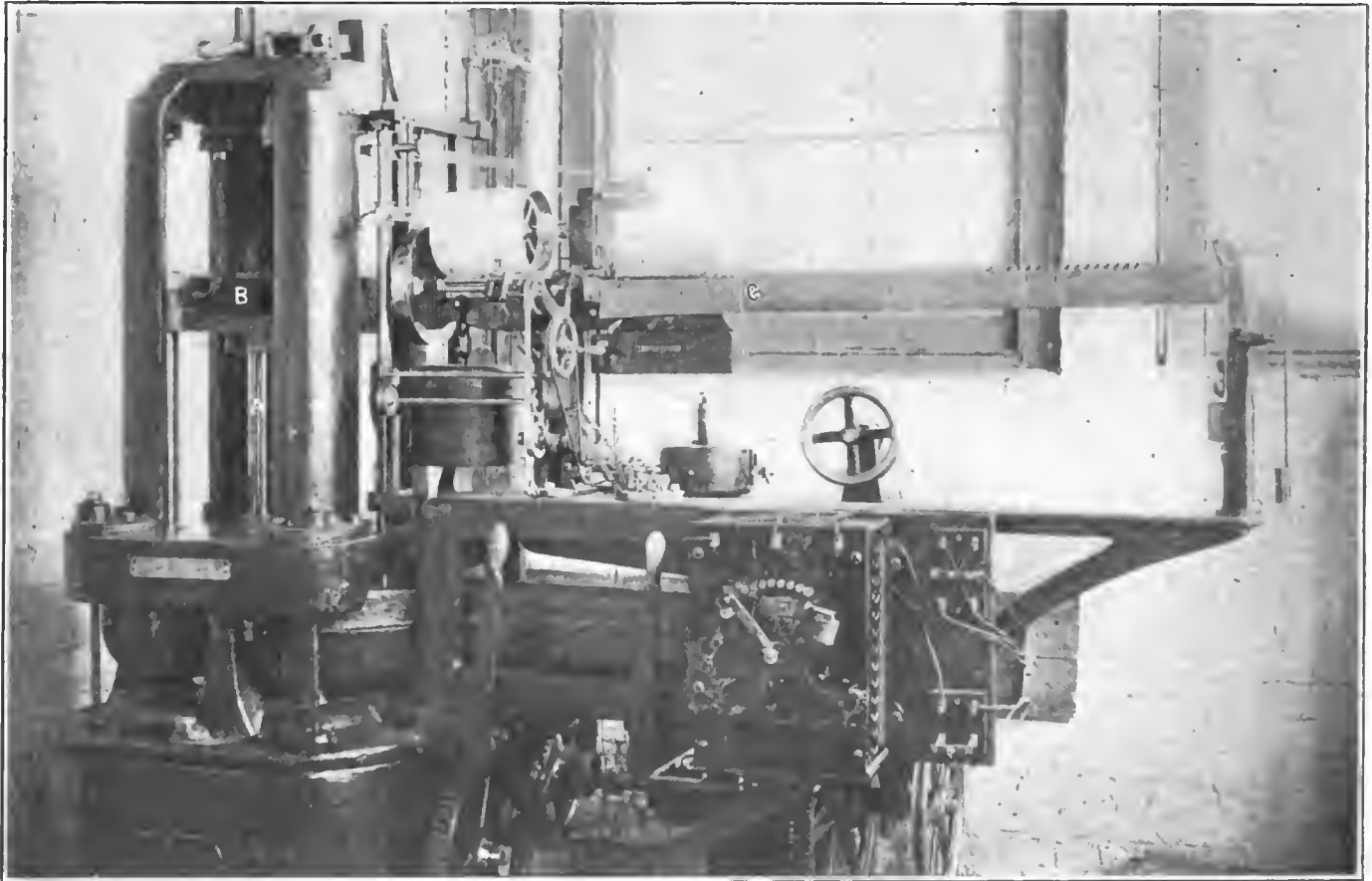

Fig. 1—Type of machine used to determine the tensile strength of metals



**T**ENSILE strength is a term frequently used by engineers and designers of automobiles, as well as by those who are manufacturing the metals for, or into, the numerous parts that enter into the construction of a motor car. The term is so familiar to them, they never

think that the buyer or user of a car is nearly always one whose line of work, or energies, has carried him into other fields in which he seldom hears these words and thus has no occasion to know their meaning. Even many of those who sell cars do not always know the meaning of the term. It is therefore well to start at the beginning and define its meaning, as well as show how important it is in the selection of materials for the car's construction, or in deciding on the size and shape of the parts. It is a term that should be thoroughly understood.

## Part I.—Tensile Strength Announcement

In this issue **THE AUTOMOBILE** begins a series of articles under the title "Metallurgy Made Easy." This series will continue from week to week and will cover the entire gamut of metals as applied to the automobile. The aim of the series is to familiarize the lay reader with the terms used in metallurgy as well as the different metals, their strengths, uses, etc. The articles are written in language to suit the beginner, the man who has heard of tensile strength, elastic limit, reduction of area and the many other terms. The series will take up in elementary form the different metals which enter into the construction of the automobile, including Bessemer steel, open-hearth steel, electric furnace steel and the many other steels. Readers desiring additional information on the subjects treated in the different articles are requested to write to the Editor and questions will be answered and discussions solicited.

Next week, elastic limit will be the subject.

In selecting the different metals that make many of the parts of a complete automobile one of the most important things to know is the tensile strength of each kind. To obtain this, samples or test bars of each kind are prepared and these placed in a tensile machine similar to the one shown in Fig. 1.

The test bar is first clamped at both ends and pulled apart when the machine is started. The part B, which grips the upper part of the test bar, is then gradually raised by a screw and this stretches the test bar until it breaks. The number of pounds that are required to break this test bar is shown on the scale at C and this is known as the tensile strength. In order to standardize this so it can be compared with all bars tested, it is computed in the pounds required to break one square inch

of the surface across the part where the bar is broken.

The test bars are usually made of a definite size before they are broken so that the pounds per square inch can easily be computed and thus made reliable. In Fig. 2 there is shown the standard shapes that have been adopted for both the steel and cast iron

test bar. D is the steel test bar, which is threaded on both ends and has a standardized length between the threaded portions, as well as a standardized diameter. It is screwed into dies that are supplied with the machine and these are held in place by wedges that are also a part of the machine. Test bars that are not threaded may be gripped with the device that holds the cast-iron test piece. Thus square, hexagon, octagon and other shapes may be tested. The diameter of these bars in the center where the break occurs is 0.505 inch and this gives an area of 1.5 square inch. The reading obtained from the scale at C is thus multiplied by five, in order to obtain the tensile strength per square inch.

When it is understood that the tensile strength of the different steels varies from below 60,000 to nearly 300,000 pounds per square inch one can readily see the importance of the tensile strength of the various parts that go to make up and complete the automobile. When the steels of the lower tensile strength are used, the sectional area of the piece, that is, the distance through the thickness, or the width, or both, must be greater than when the steels of the higher tensile strength is used. For many parts of the car almost any metal is sufficiently strong, and for these the metals of the lower tensile strength can be used, as these are invariably the cheapest. There are many parts, however, where strength is of vital importance, and for these it is necessary to know the tensile strength of the material to be used before the designer can say what size it is to be made or from what material.

The higher the tensile strength is in the steel the higher will be the cost of the materials used in its manufacture, as the greater will be the amount of labor and skill required in its manufacture. If steels of the lower tensile strength per square inch are used, the number of square inches in their sectional area must be much greater than when steels of the higher tensile strengths are used. This would make the various parts heavier than they need be and would add greatly to the weight of the complete car. It would thus require considerably more engine power to drive it than would be the case when metals of a higher tensile strength are used. The difference, therefore, between cheap metals that must be comparatively large in section—owing to their low tensile strength and the higher-priced materials that have a high tensile strength and can be made comparatively small in section is often a difficult problem for the engineer and designer. Sometimes the high-priced materials are as cheap to use as the low-priced, owing to the fewer pounds that are needed from which to manufacture the given part. Occasionally a designer has used the cheaper material and made it the same size as he would the more expensive material, but this nearly always resulted in a breakage.

Some factors that affect the tensile strength of steel to a large extent and of other metals to a lesser degree are their mechanical working: that is, after steels are rolled, pressed or forged their tensile strength is considerably greater than when they are first cast into ingots. Likewise, the steels, especially, have their tensile strength greatly altered by their heat treatment: that is, anneal-

steels are considerably lower in tensile strength than steels that have been properly hardened and tempered. This greatly benefits the different parts of an automobile.

It is not the purpose of this article, however, to go into details of design, what materials should go into the various parts or the working and treatment of the metal. Its object is to call attention to the necessity of having them of the required tensile strength.

Aluminum is very light but has very little tensile strength, this being from 12,000 to 20,000 pounds per square inch. It, therefore, is used for engine cases, gearboxes, and such parts as keep dust and dirt away from the working parts, and are not subjected to any great strains and stresses. It makes the car lighter and less engine power is needed to drive it.

An attempt is being made to use sheet metal for these parts, owing to the weakness of aluminum castings. The sheet metal would have a greater tensile strength for the same weight but is quite difficult to form into the shapes needed and supply them with the thick bosses and lugs that are required in various parts of such cases.

Other parts, such as carbureters, levers of many kinds, etc., are made from the brasses and bronzes. Castings from these vary in tensile strength from 30,000 to 85,000 pounds per square inch and are useful in many places where great strength is not required, but more strength than aluminum gives.

For many other parts malleable iron, cast iron, steel castings and other metals are used. These vary in tensile strength from the 5,000 to 10,000 pounds of the bearing metals to the 85,000 pounds per square inch that is shown by some steel castings. Bearing metals, however, only require compressive strength, which is the opposite of tensile strength. That is, instead of pulling apart the test bar, it is squeezed or compressed until it gives way or is crushed; the number of pounds required to crush it being its compressive strength.

Of the steel parts, such as steering knuckles and their connecting rods, the best of metals that have a high tensile strength must be used. Breakage of these means that the driver cannot steer the car and unless he can stop it suddenly, a bad accident is liable to occur. Quite a number of accidents of this kind have resulted

in occupants of the car losing their lives. The crankshaft of the engine is another part that is given great strains every time an explosion occurs in the cylinders and this must have a good tensile strength. The driving shaft, axle shaft, transmission gears with their shafts and differential gears are some of the other parts that are subjected to great strains and stresses and consequently must have considerable strength.

The strains and stresses produced in an automobile by its traveling over rough roads make it imperative that the frame, front and rear axle, driving shafts and gears and all the moving parts have the required tensile strength, as on this largely depends its life and safety, as well as the safety of the car's occupants.

If any of the materials used are porous, spongy or full of blowholes there is an interruption in the cohesive force that binds the molecules of the mass together and hence it cannot have the tensile strength that it should.

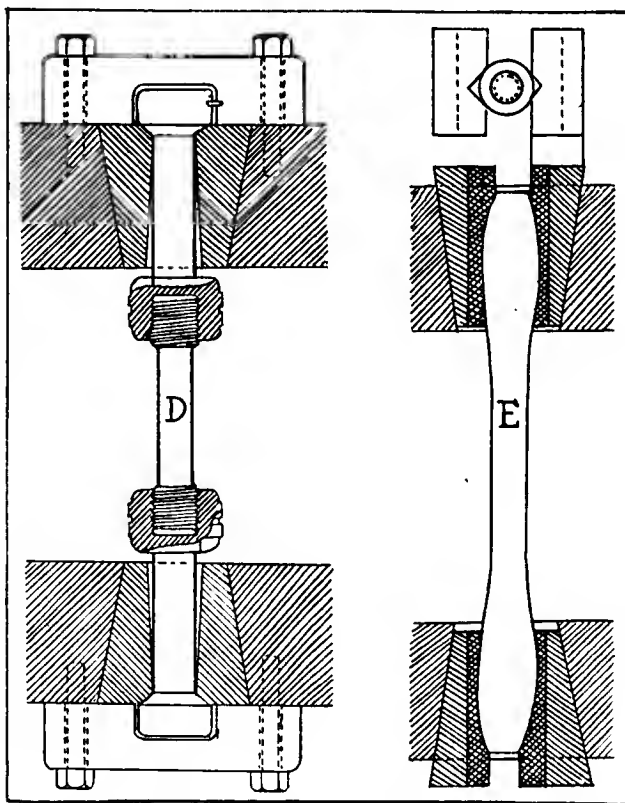

Fig. 2—Standard shape adopted for steel and cast iron test bars

# Knox Adopts Long-Stroke Motor

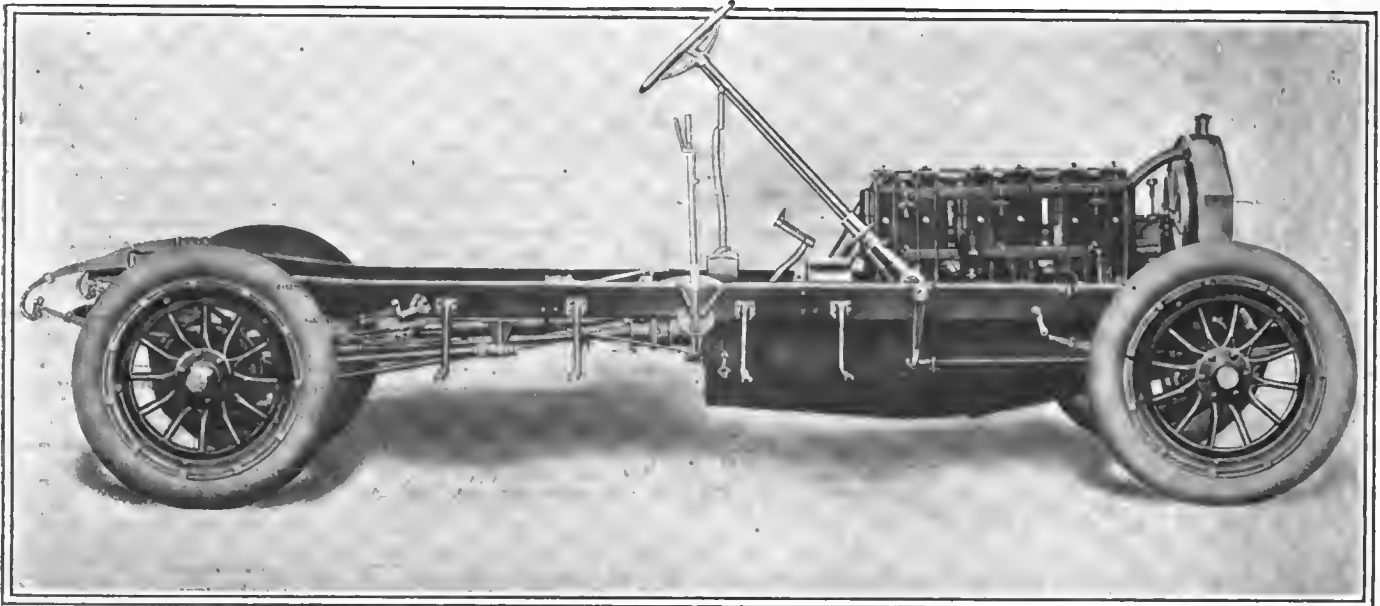
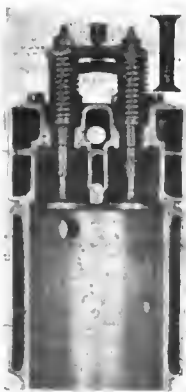

Fig. 1—Side elevation of the six-cylinder Knox chassis, showing suspension and control



IN bringing forward the line of cars for the season of 1912, the Knox Automobile Company, of Springfield, Mass., has departed from its time-honored policy of building nothing but short-stroke motors and has adopted, in connection with the new chassis which features this year's output, a motor having a 1.1 bore-stroke ratio. The ratio which is used in connection with the other motors constructed by this company is .95.

The new motor has a bore of 5 inches and a stroke of 5.5 inches, giving a horsepower of 40, according to the A. L. A. M. rating. The motor has four individually cast cylinders, as may be seen in Fig. 3. The cylinders are water-cooled, the water-jackets being cast integrally with the cylinders. The valves are located in the cylinder heads and are operated by means of rocker arms R and tappet rods T, which take their motion from the camshaft C, located on the right side of the motor. The cylinder heads are removable, being attached to the body of the cylinder by means of four bolts which screw into bosses on the cylinder casting. A copper asbestos gasket is placed in the joint between the head and body of the cylinders so that it will be secure against leakage. The gasket fits into a deep groove in the upper part of the joint, while a concentric tongue fits into the groove G and holds the gasket tightly in place. The valves V are of the flat-seated type, according to the practice maintained by the Knox concern. They are made from a solid piece of nickel steel alloy and are of generous proportions, thus allowing for a wide seat. Both the tappet rods and upper ends of the valve stems have cup-shaped openings to receive the case-hardened ends of the rocker arm; oil is placed within the cup in which the ends of the rocker arms work in order to eliminate noise to the greatest possible extent and to prevent undue wear upon unlubricated surfaces. To further prevent noise an auxiliary is fitted in addition to the regular valve spring, thus making up all lost motion and increasing the efficiency of the whole mechanism.

The regular valve spring and auxiliary are shown at A and B.

The crankshaft is a drop forging running upon five plain bearings which are carried on webs in the crankcase casting. The crank bearings are fitted with babbitt bushings which are recessed, thus forming a firm bearing for the connecting rod. The pistons are flat-head castings having three rings above the wristpin and one near the bottom of the piston. The wristpin is firmly attached to the boss, into which it is fitted by means of a set screw which passes completely through the pin and into the boss. The connecting rod bearing cap is fastened by means of four bolts of large diameter. These bolts pass through bosses in the connecting-rod end.

The camshaft which operates the tappets is made from a single solid bar of nickel steel, finished and ground to size. The cams and gears are cut integrally, while all the wearing parts are ground to size and then hardened. The shaft runs on three plain bearings which are lined with phosphor bronze; the central bearing is split and can be adjusted for wear.

## Same Lubrication System Used

The new motor is lubricated in a manner identical with that of previous models of Knox cars. The system used is the force feed, the oil being kept in constant circulation by means of a gear type of pump. The pump is driven by means of a vertical shaft which is operated directly off the camshaft. This shaft not only drives the oil pump but also rotates the timer. The oil reservoir is in the lower half of the crankcase and forms an integral part of the engine casing. The oil level in the reservoir is never permitted to rise to such a height that the connecting rods will dip into the oil, as this would put too much oil into the cylinders and cause the motor to smoke.

The oil pump, which is of the gear type, draws the oil from the reservoir in the crankcase and forces it through the main oil feed pipe to the other side of the motor, where it is led into a longitudinal pipe. The leads for the main bearings are tapped into this pipe. Oil is forced into the crankshaft once in every revolution when the opening in the shaft registers with the opening in the oil lead. The crankshaft is drilled as well as the

crank-checks and the crankpin; the oil flows along the crankshaft under pressure and is thrown into the crankpin by centrifugal force due to the revolving shaft. The crankpin has an opening drilled through it in a direction perpendicular to the axis through which the oil will flow to the bearing by centrifugal force. This opening registers with an opening in the lead to the wristpin bearing through which the oil will flow. A certain amount of oil is thrown from the cranks as they revolve and this suffices to lubricate the cylinder walls. The surplus oil drains back to the reservoir, whence it is again drawn through the system after having been passed through a wire mesh strainer.

A noteworthy feature in connection with the lubricating system on the Knox cars is the spring connection on the pump shaft. This is so arranged that in case the pump becomes clogged nothing important will be broken as the spring will snap past the catch. A pressure gauge showing the pressure head delivered by the oil pump is located on the sloping floor-board of the car. The oil is supplied to the tank on the left side of the motor and the quantity contained therein may be at any time determined by means of a level gauge cock.

### Two Systems of Ignition

Ignition is effected by means of two independent sets of spark plugs, one of which is operated by means of a Bosch D-4 type magneto, located on the left side of the motor, while the other set of plugs for starting purposes is connected to a Columbia battery set and a 4-unit Connecticut coil. The two-way switch is located on the dash in the usual manner. These two systems are absolutely independent of each other and hence may be operated at the same time if desired, or in case of the derangement of either, the car may be readily run upon the other set.

The water circulation is maintained by means of a centrifugal pump. The water enters the cylinder jackets at the lowest point and has its outlet near the top on the right side. The water

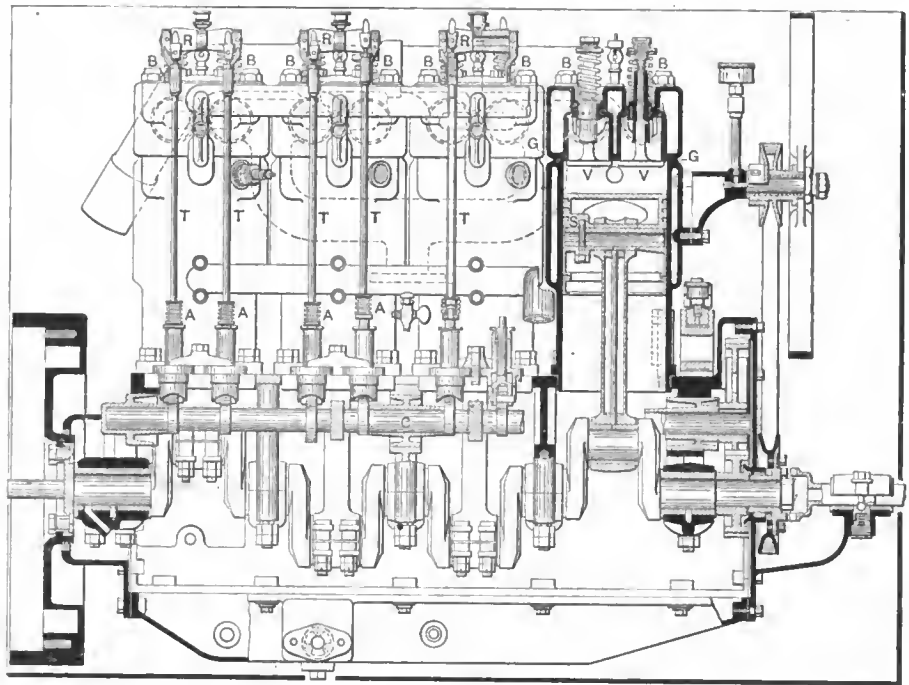

Fig. 2—View of the new Knox four-cylinder, long-stroke motor

does not pass through the joint made by the connection of the cylinder head and cylinder castings, but passes from the lower casting into the upper by means of an outside fitting. Each casting, therefore, will have two water connections, an intake and an outlet. The radiator used in connection with the cooling system is of the tubular type.

The carburetor used is of the Stromberg make, having a single jet and float feed. It is located on the left side of the motor and supported by the Y-shaped intake manifold.

The clutch may be seen in Fig. 4. It is of the three-plate dry type and is provided with cork inserts in the cast-iron facing. The clutch is located in the flywheel as shown and the tension is maintained by means of coil springs which hold the frictional members of the clutch tightly in place. Easy disengagement is effected by means of the clutch pedal operated from the driver's seat, this pedal actuating a sliding sleeve which in turn disengages the plates. The whole clutch mechanism is enclosed in a dust-proof casing which serves to protect it from dirt and

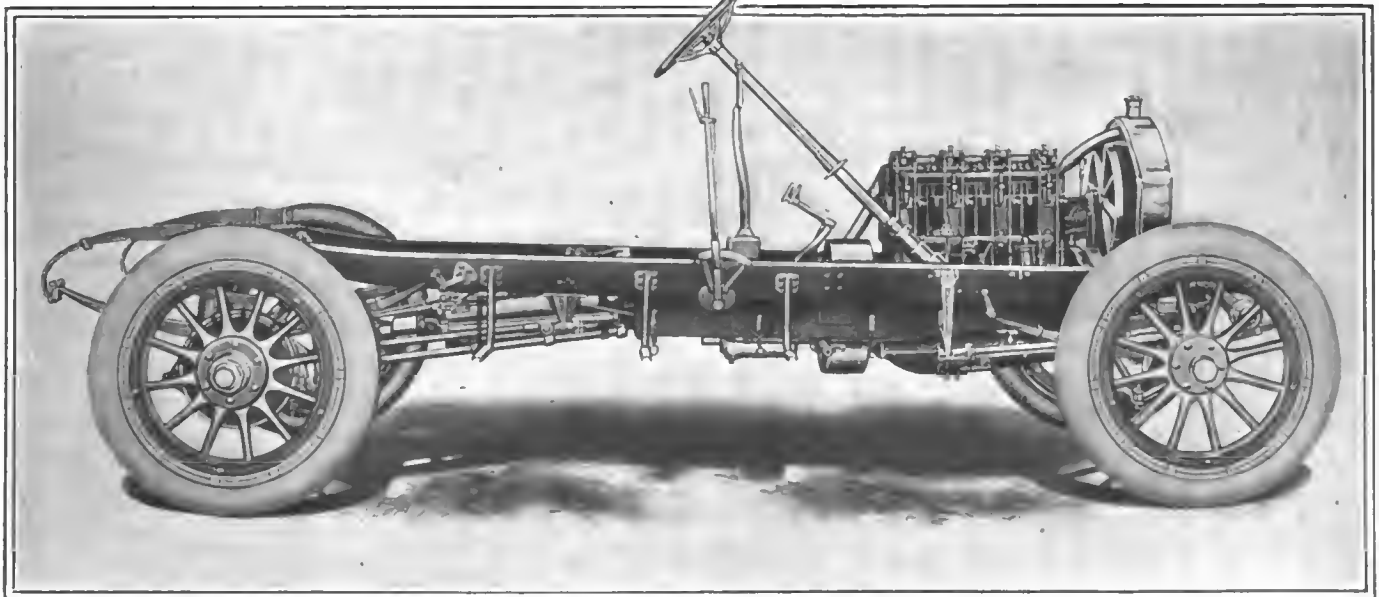

Fig. 3—Chassis used in connection with the Knox four-cylinder, long-stroke motor

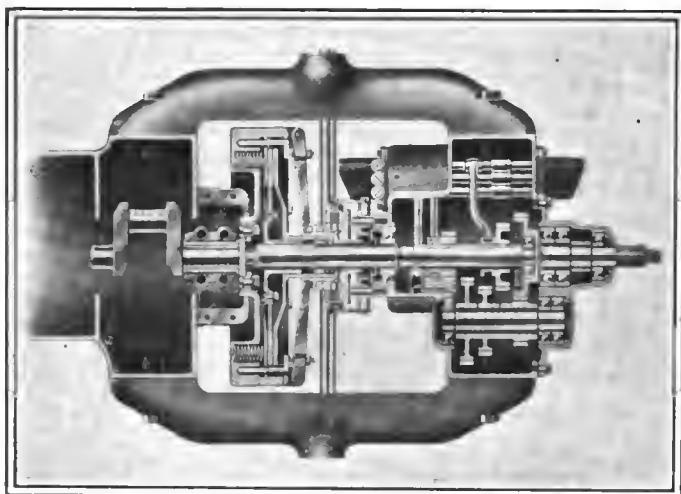

Fig. 4—Plan view of the clutch and gearset housing with the cover removed

water. The casing is easily removable, making the clutch parts accessible with little trouble in case it is necessary to make an examination or adjustment.

The gearset is of Knox design and is of the three-speed and reverse selective type which has been common to the Knox cars in the past. It is shown in detail in Fig. 4. A slight change has been made in one of the details of construction in that the rear of the main shaft and the lay shaft run on a double row of Hess-Bright ball bearings. Both the shafts and gears in this part of the transmission are made of nickel steel, the shafts being specially hardened while the gears are so constructed as to do away with keys. No universal joint is used between the clutch and the gearset, the two being so constructed that one is practically a continuation of the other. They are covered by the same housing and are separated by means of a packing gland inserted in a partition in the housing which serves to divide the clutch and gearset compartments as well as to provide a means of stiffening the construction.

#### Features of the Knox Drive

A universal joint is placed just aft of the gearset housing, separating it from the propeller shaft. Another universal joint is provided at the rear end of the shaft to take care of any changes which may occur in the alignment of the drive owing to the different compressions of the springs under varying loads. The power is transmitted through the shaft and then to the dif-

ferential. The differential shaft is a short member and is carried by a ball bearing at either end. At the rear end the bevel pinion, which is an integral part of the short shaft, engages with the large bevel wheel which operates the differential; this gear wheel is also carried upon ball bearings which are supported by means of webs in the differential and floating axle housing. The axle shafts are also carried upon ball bearings at either extremity and are easily accessible by simply removing the hub cap, which discloses the ball bearings upon which they are carried. The live axles are squared at their inner ends so that they may be readily withdrawn for inspection, by simply pulling them out. The differential gears are very easily accessible also and may be taken out of the housing by removing the casing cover which is fastened by means of a series of small bolts. The differential and axle housing are of pressed steel while the gears themselves are of nickel steel.

The brake drums are located on the rear hubs. The service brakes are operated by means of a pedal from the driver's seat and are of the contracting type, having a face of 3 inches in width and 14 inches in diameter. The bands are held free from the drums at top and bottom by springs which are rendered adjustable by means of lock nuts. The emergency brakes are of the internal expanding type and are operated by a hand lever. A movement of the lever turns a cam which is so arranged that it will spread the two shoes of the brake apart, causing them to bear against the internal surface of the drum. The shoes are lined with Raybestos and are kept free from the drums when not in use by means of springs. Both brake outfits are controlled by equalizers which are so constructed that an equal pull will be exerted upon each brake.

#### Details of the Knox Chassis

The wheels are of the wood artillery type, equipped with Fisk bolted-on tires mounted on demountable rims of the same make. As an option, Universal rims and clincher tires may be had by the purchaser. The sizes usually fitted are 37 x 5 inches, although the rims will also accommodate 36 x 4.5-inch tires. The wheelbase is 126 inches and the tread the standard 56 inches.

The chassis frame is of unusually heavy construction and has a single drop. The depth of the metal in the new model chassis is 5 inches while the width of the channel flanges varies at different points along the length of the chassis in accordance with the distribution of weight and strains. The flanges of the side members widen rapidly from the attachment point of the front spring shackle and extend back with unusual width until past the point of power unit support, from where the flange tapers back to standard width. There are three cross members to the



Fig. 5—Interior of the limousine and the rear of the touring model. Note tire trunk



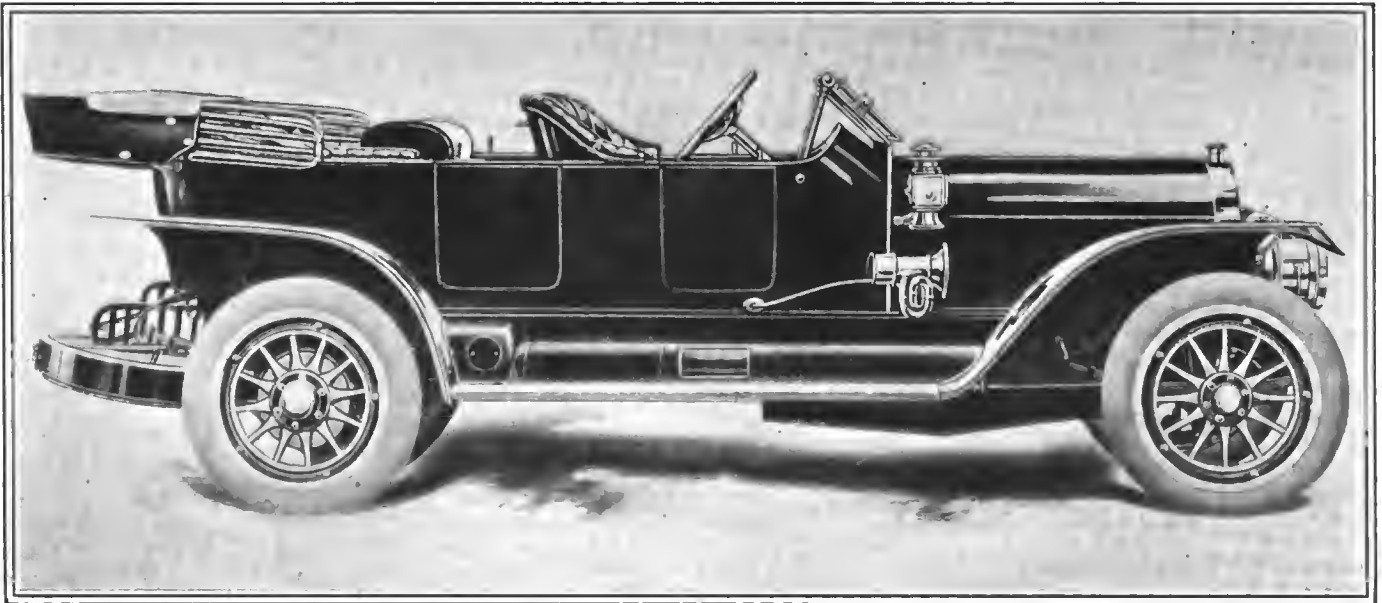

Fig. 6—The fore-door, seven-passenger touring car with six-cylinder motor

frame, one at the extreme front end, another at the rear and the third at a point just above the forward universal joint in the driving shaft. The latter carries the forward extremity of the torque rod. The two engine supports also form sub-cross members as they help to stiffen the frame, and in a somewhat lesser degree the three tubes in the brake mechanism help to do the same thing. The material of the whole frame, in so far as the main and sub-members are concerned, is of cold pressed, heavy gauge nickel steel.

#### Features of the Knox Suspension

Semi-elliptic front and three-quarter elliptic rear springs are used on all models of the Knox cars. The front springs are 42 inches long and the rear 54 inches. They are of alloy spring steel and are made by the Spring Perch Company. Shock absorbers are fitted to all the springs in order to give an easy-riding car with a long-lived suspension. Spring lubrication is effected by means of extra large grease cups which are fitted to the shackle bolts. Shackle bolts and pins are all hardened and ground to size.

Steering is done by means of an irreversible gear of the double left- and right-threaded worm type. The two worms are operated through an 18-inch hand wheel and are connected to the nickel steel rocker shaft by means of a drop arm. The steering column is bolted to the frame and secured in such a manner to the footboard that no vibration will be felt in the wheel. Adjustment for wear is readily made by means of a large nut located on the exterior of the steering gear housing. The fore-and-aft rod is straight and the socket ends are provided with springs to eliminate rattle.

The chassis described is known as the model R-45 and marks the first long-stroke motor built by the Knox people. The other models are the same as those made in former years. No marked changes have been made except in some minor details. The other models made are known as R, S, R-64 and R-3. They are all equipped with four-cylinder engines except the model S, which has a six-cylinder motor.

The equipment fitted to all Knox cars is complete and is as follows: Magneto with cover, Jones speedometer, Gray & Davis lighting system, Presto-O-Lite tank, combination oil and electric side and tail lights, horn, foot rail, robe rail, motor tire pump, gasoline gauge, extra rim, tire cover, tire carrier, number plate holders, steering knuckle covers, top and side curtains, windshield, clock, full set of tools, etc. The colors are optional with the purchaser and in the case of the limousine all the additional fittings necessary in this type of body are included. The

tool boxes are arranged upon the foot-board in a convenient manner. The bodies are constructed throughout of sheet aluminum and steel over oak and ash frames.

A large number of details are left optional with the purchaser. These details are not only of minor importance but also embrace the principal features of the construction of a motor car. The motor is one of the optional points. The Knox company believes in the short-stroke motor and for that reason continues to feature them in their line of cars for the coming year; still, at the same time the great amount of popular feeling in favor of the long-stroke type of motor is recognized and hence this style of engine has been incorporated in the Knox line. The purchaser is given the choice of either the long or short motor in any model of chassis which he chooses to select. If the short-stroke type is specified on the regular stock model an additional charge is made for the installation of the long-stroke motor. The same latitude of choice is allowed as far as four- and six-cylinder motors are concerned or left or right control as well as in many other points throughout the car.

#### Radiators Starting to Freeze

The time of the year has now arrived when it is dangerous to leave the radiator unprotected. It may be well to remember that if 1 1-4 quarts of denatured alcohol are added to each gallon of water the mixture will freeze at 5 degrees below zero.

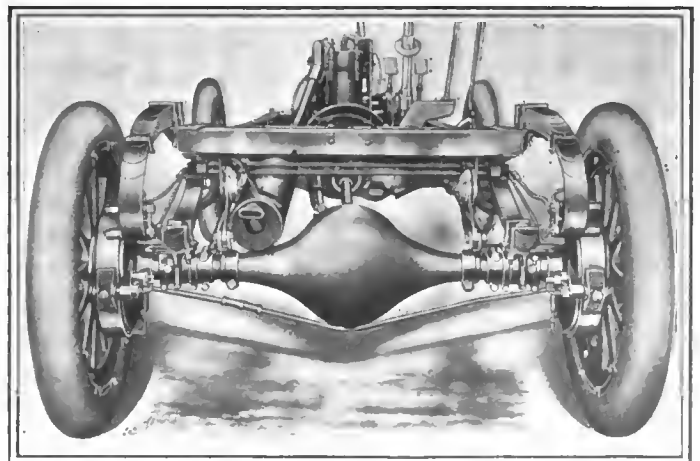

Fig. 7—Rear view of chassis, showing the Knox rear axle construction

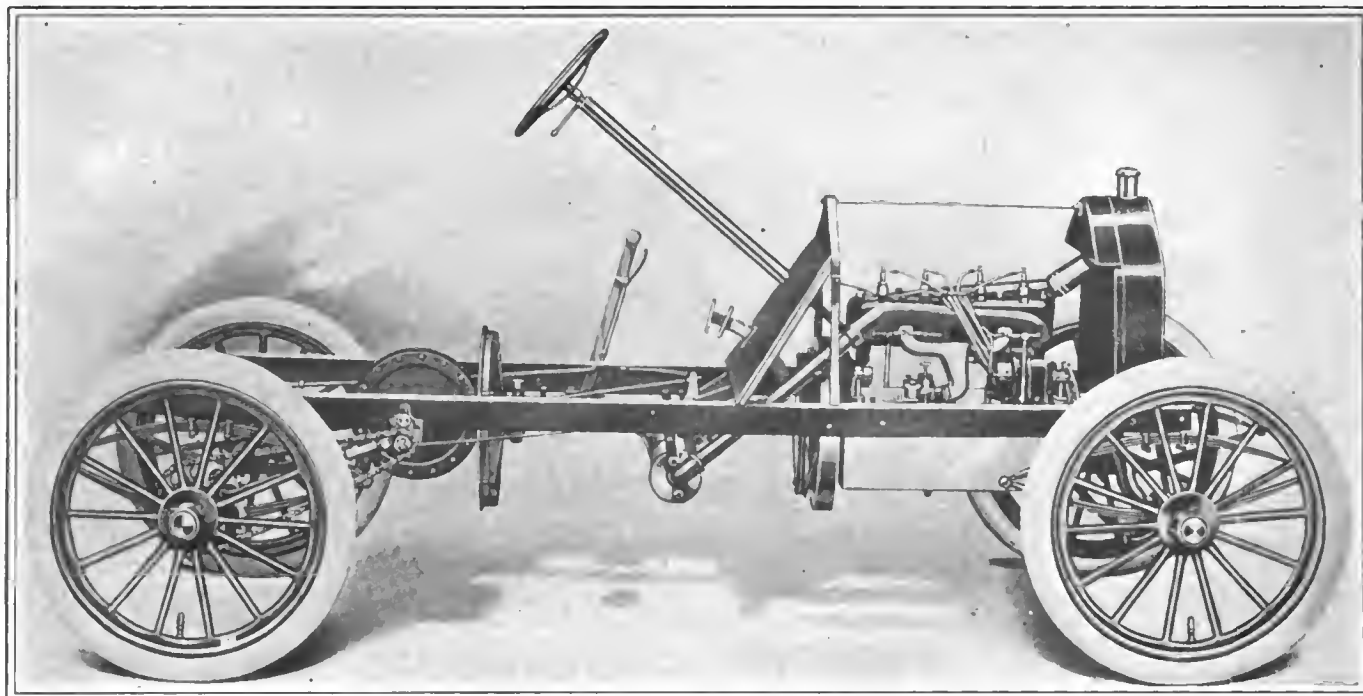

Fig. 1—The chassis of the 1912 Metz car is shown here in elevation

## Few Changes Mark the 1912 Metz

THE Metz Company, of Waltham, Mass., makers of the Metz 22, have continued their product for the year 1912 without making radical changes in the design of the car.

The motor is rated by the makers at 22 horsepower and is of the four-cylinder en-bloc type. The bore is 3.34 inches and the stroke 4 inches. The motor is illustrated in Fig. 2, where it is shown partly in section so that a fair idea of the simplicity of design, which has been made a feature in the construction, may be obtained. The waterjacketing is cast integrally with the cylinders, the upper half being removable and held in place by means of stud bolts, which may be seen in the illustration. The mani-

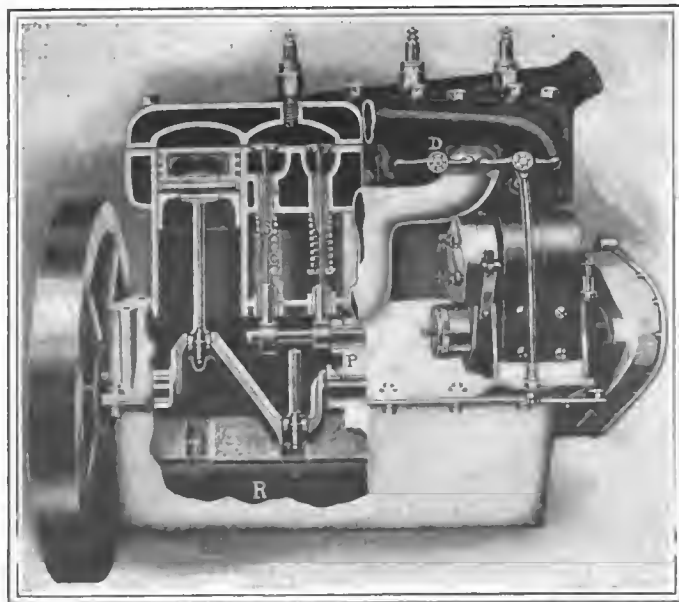

Fig. 2—Semi-sectional view through the Metz 22-horsepower motor

olds are held to the waterjackets by means of the dogs D which are secured by the stud bolts that pass through them and terminate in bosses on the cylinder casting.

The pistons are constructed with flat heads and are of square section, that is, having the same length and diameter. Three piston rings are fitted, all of them being above the wristpin. The wristpin is fitted within a bossing in the piston casting and is solidly connected thereto. It does not oscillate with the connecting rod. The connecting rod is of I-beam section and is fitted at the crank extremity with a cap which covers the bearing and which is fastened by means of two bolts which pass through bosses on the cap and connecting rod.

The crankshaft runs upon three main bearings, those at the extremities being supported by the walls of the crankcase casting, while the central main bearing is carried upon a bridge which is formed by a web in the casting. The camshaft is located upon the right side of the motor and operates both the exhaust and inlet valve actions. The valve-lifter action is simplified by having the cams act directly upon the push rods, thereby doing away with the lifter and follower mechanism generally employed. The camshaft is also carried by three plain bearings of ample length, located at the ends and center of the shaft.

The valves are of two-piece construction, the stems working in the guides G. The springs S are long and of sufficient strength to secure positive valve action. The spring caps C are flanged in order to hold the springs firmly in place and eliminate noise to as great an extent as possible.

The crankcase of the motor is cast in two parts, the lower half being independent, while the upper half is integral with the cylinder and waterjacket castings. The two parts of the crankcase are fastened in the usual manner by means of bolts which pass through the flanges. A packing is placed between them, thus eliminating oil leaks.

The motor is cooled by water which is circulated by means of a centrifugal pump. The water passes through a square tube

radiator before being again circulated through the cooling system. The radiator is kept cool by means of a fan formed by the pitched blades of the flywheel. Easy circulation is maintained by means of the large waterjacketing space which is so arranged that it is not constricted at any point. The valve passages are also well cooled.

The carbureter is located on the right side of the motor, being supported by the intake manifold and the motor frame. The gasoline is fed to the carbureter through a straight pipe connection and flows by gravity. The tank is located behind the driver's seat and has a capacity of 7 gallons.

The motor is lubricated by the splash system, of which a good idea may be had from the illustration. The oil reservoir is contained in the lowest part of the crankcase and is shown at R, Fig. 2. The oil is put into the crankcase through the filler hole which is provided with a screen through which the oil must pass and which will remove any impurities or foreign matter from the supply. A gear pump which is actuated by the camshafts lifts the oil from the reservoir and places it in the upper part of the lower half of the crankcase. The splash troughs are located here and are shown at T.

An oil pocket is provided at P so that the central main bearing will receive an ample supply of oil. The oil is caught up in the pocket and then drains through the hole shown into the bearing bushing, which is thereby lubricated. The oil after having been used will drain back to the lower part of the crankcase by means of the overflow holes provided. It passes through a screen before reentering the pump to be sent through the system again. The capacity of the oil tank is 5 quarts.

The car is operated by friction drive with five speed changes. The power transmission is illustrated in Fig. 1, the shaft is continued past the flywheel and terminates at a point about amidships in a friction wheel. The other or driven member of the pair of friction wheels which characterizes this car is placed upon a transverse shaft which is carried upon bearings supported by the frame. The driven wheel rests upon a sleeve which can be shifted in a direction parallel to the axis of the shaft. When the perimeter of the driven member is in contact with the outermost circumference of the driving wheel, it is apparent that the maximum speed will be obtained. Variations in the speed may be had by shifting the driven wheel so that the point of contact between the two wheels is at different distances from the center of the driving member. Power is transmitted from the

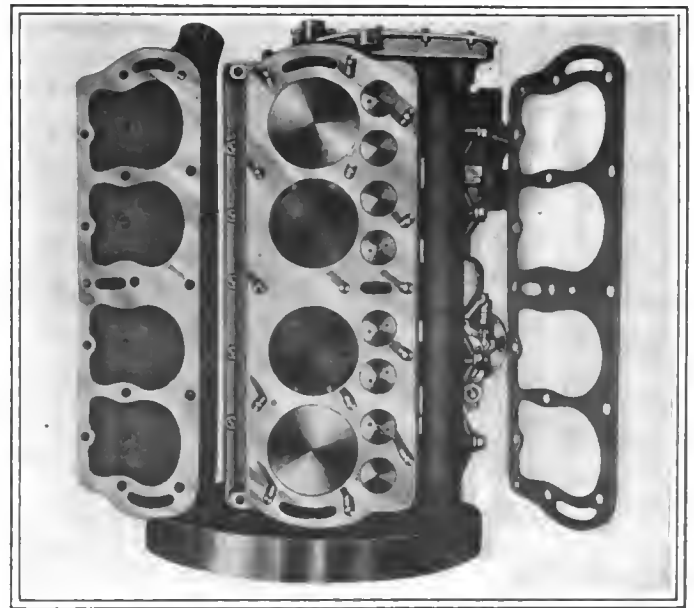

Fig. 3—Plan view of the en bloc cylinder casting on the Metz motor

transverse shaft to the rear wheels by means of two chains, one on each side of the vehicle. The ratio of reduction of the power from the transverse shaft to the rear axle is 4 to 1.

The brakes are located at the wheel hubs and are of the disc type. They are controlled by pedal from the driver's seat.

The chassis is hung upon elliptic springs both front and rear; the rear springs consist of four plates and are 11-2 inches in width and 30 inches in span, the front springs have exactly the same dimensions and constructive details. The front axle is of drop-forged manufacture. The side members of the chassis frame are of channel section straight construction, having a depth of 3 inches and width of 1 1-4 inches.

The wheels are of the artillery type, each having 14 spokes, and being provided with Mott steel rims. The tire equipment regularly fitted consists of a full set of 30 x 3-inch tires.

The car is sold fully equipped with high-tension magneto, tires, tools and top, and complete weighs about 1,000 pounds. It is designed for two passengers.

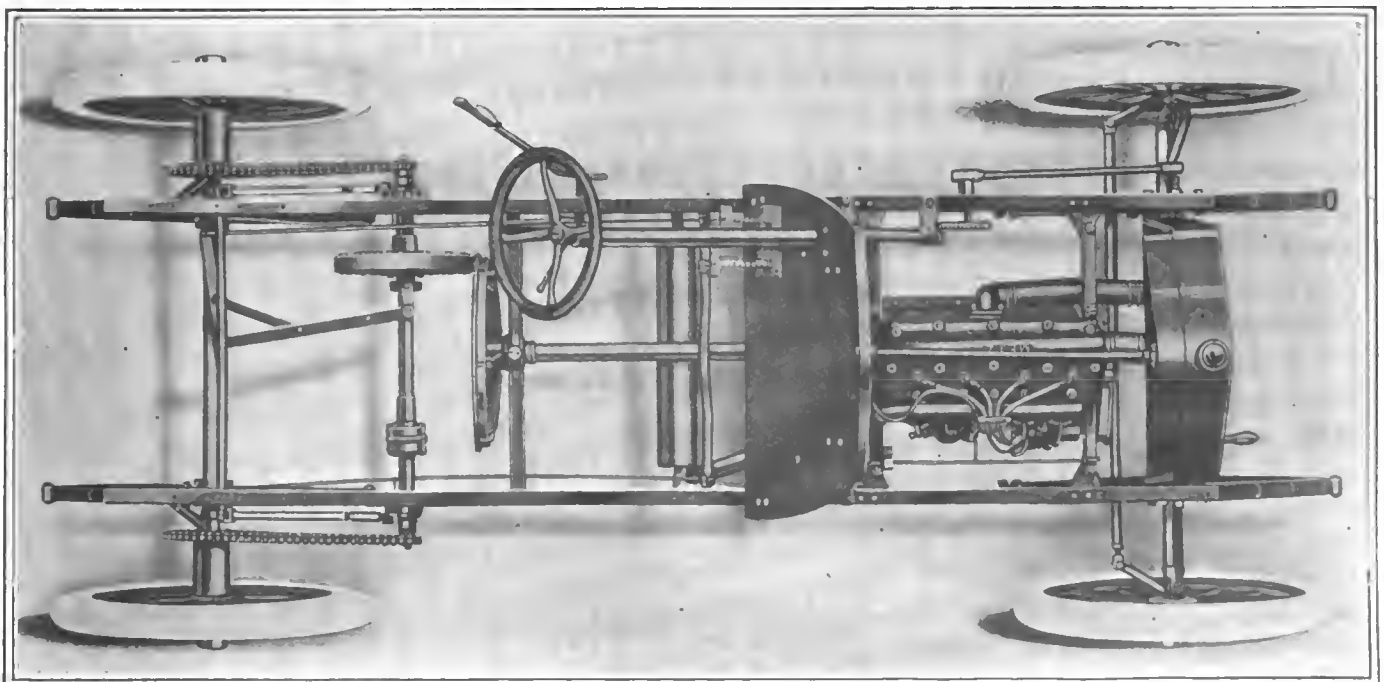

Fig. 4—Plan view of the standard Metz chassis, showing friction drive

# Acetylene and Its Uses

**A**CETYLENE, as everyone knows, is generated when calcium carbide is brought into contact with water. Carbide is a compound consisting of calcium (a metal which may be burned to form lime) and carbon (the element used wherever heat is to be produced in commercial quantities). Calcium carbide, however, is not made directly from its elements, calcium and carbon. It is produced by heating, in the electric furnace, a mixture of lime (calcium oxide) and coal (carbon). In this process part of the coal combines with the oxygen of the lime and is freed as carbon dioxide, while the rest of the coal reacts with the calcium, resulting in the formation of calcium carbide. But this reaction takes place only at a very high temperature, and during the process vast quantities of electric energy are absorbed by the carbide and stored in a latent form of energy, generally referred to as chemical energy.

Owing to the low price of carbide, its production may be profitably carried on only where electric power is available at a low price, such as near a waterfall, and at places not too remote from the localities of carbide consumption.

If water is poured on calcium carbide the following reaction takes place: Water, which consists of hydrogen and oxygen, loses its oxygen content, which combines with the calcium and forms lime; the carbon of the carbide and the hydrogen of the water form acetylene gas, which has the formula  $C_2H_2$ . One pound of acetylene is composed of 12-13 pound of carbon and 1-13 pound of hydrogen, and contains about 17,500 B. T. U. This is a tremendous amount of energy, and since the lime by the formation of acetylene contains no more energy than it originally possessed this number of B. T. U. represents the total of the energy absorbed in the electric furnace. The usefulness of acetylene is founded upon this high energy content, which, however, is also a source of danger, especially so if impurities are taken up by the gas. If this is the case acetylene is liable to be decomposed into its elements, carbon and hydrogen, and the high energy content to be set free, causing a considerable detonation.

Pure acetylene has hardly any smell at all. The stench popularly ascribed to it is caused by the impurities often contained in it. The dangers accompanying impurities in acetylene are practically obviated by using the so-called autogas, which comes in tanks. Here the acetylene is dissolved in acetone, a by-product of wood-tar distillation. In filling the gas tanks, these are first filled with acetone, a gelatinous mass. Then the acetylene is pressed into the tanks and is readily absorbed by the acetone, which, under a pressure of 176 pounds per square inch, is capable of dissolving acetylene of a volume 300 times its own. In this state, acetylene is quite a safe substance; a platinum wire made incandescent in a hermetically sealed, full tank fails to ignite or decompose the acetylene. Besides being explosion-safe, gas tanks are clean, economical and may be put in use almost instantly.

The acetylene emerging from gas tanks is pure and therefore less dangerous than the impure gas, when it comes in touch with copper pipes. Copper, as is well-known, is very apt to form verdigris if given a chance to combine with water and air, and verdigris, in turn, combines with acetylene to form acetylide of copper, one of the most explosive materials known. It is for this reason that copper piping should never be used for acetylene leads.

The most extensive application of acetylene is for lighting purposes. Acetylene has quickly found favor with the automobile public because of its intensely white light, which is generally considered the whitest artificial light and, in fact, is as

white as sunlight. The cause of this phenomenon lies in the high energy content of the acetylene. The 17,500 B. T. U. contained in 1 pound of the gas develop a very high temperature—about 2,300 degrees Centigrade—if the gas is ignited. At this temperature carbon is white-hot, producing the purest white light there is. The high carbon content of acetylene, remembering that it constitutes 12-13 the weight of acetylene, accounts for the enormous quantity of white light produced by a very small flame. If a reason for the ability of carbon to produce a high temperature is sought it may be found in its black color. Black matter heats up much more rapidly than white material, and, just as in walking in the sun, a black coat seems much warmer than a white one, so coal, when it is heated, quickly attains a much higher temperature than silver or platinum, for instance. If a coal mark be made on a platinum sheet, and the sheet heated in a flame, the coal mark becomes white hot before the platinum heats up to red glow. The higher the temperature of the heated metal the more intense becomes the light radiated by the coal marks.

Likewise, in an acetylene flame the intensely white light is made possible only by the high temperature of the burning carbon. Superficial measurements of the heat of an acetylene flame in open air would indicate an average temperature of about 1000 degrees Centigrade. Numerous and detailed experiments, however, have revealed the fact that in the portions of the acetylene flame which radiate most of the light the temperature is about 2,300 degrees Centigrade.

## Use of Generator Tanks Has Good Features

In place of the gas tanks in which acetylene is stored and transported many automobilists use generator tanks, containing calcium carbide, to which water is added when acetylene gas is required. Most generator types contain carbide, and in order to develop acetylene gas, water is permitted to drip upon the carbide. This process is simple but has many disadvantages, especially that the carbide ashes are apt to harden quickly in this process, which is accompanied by a waste of carbide. Furthermore, the material heats up quickly and part of the acetylene is decomposed immediately. A more advantageous manner of producing acetylene for use on a car would be to have the

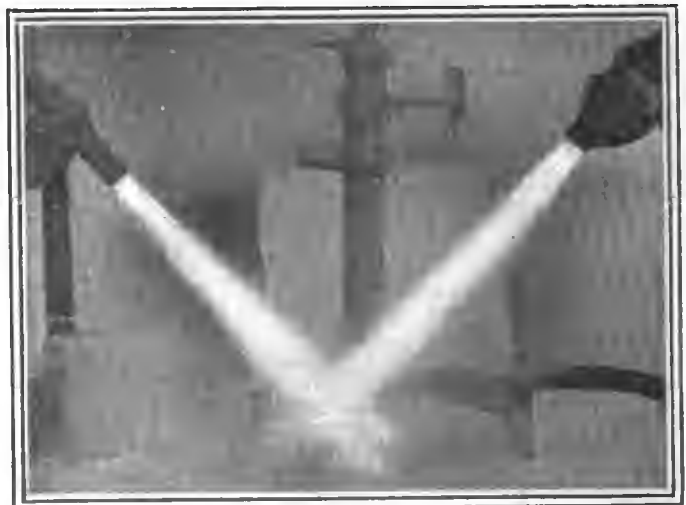

Where large portions are to be welded, two or more oxy-acetylene flames may be used to advantage

carbide grains drop into the water, whereby all the above set-backs would be avoided. But, since the construction of a generator of this type is more complicated than that of the water-on-carbide class, very little has so far been done along the carbide-in-water line despite the advantages of this system.

In order to prevent the freezing of the generator water in Winter, anti-freezing ingredients should be added, among which a small percentage of denatured alcohol is highly recommended. Salts dissolved in the water are apt to cause rust or verdigris on the gas fittings; this should always be avoided. A solution of sugar also has its good qualities, and, like the alcohol solution, reduces the violence of acetylene generation when water is admitted to the carbide.

### Autogenous Welding Opens a Wide Field

The most important application of acetylene, aside from illumination purposes, is for autogenous welding. Welding is a process of solidly joining two pieces of the same metal, without the use of a solder of a different material. Where common solders are used the work of uniting two pieces of metal may be done at a low temperature with a correspondingly low consumption of heat. But the strength of the union formed is also a low one, and where a strong metal member, such as a crankshaft, is broken and must be repaired, it is necessary to consider the fact that this part will have to do much work and is subject to great kinetic stresses. Therefore the repaired part must be made fully as strong as the unbroken portions, and to attain this end it must be welded.

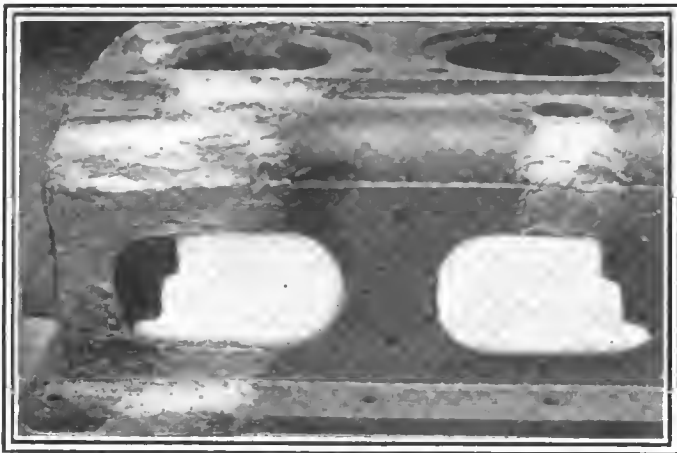

How a broken crankcase is welded by the oxy-acetylene process, after which it is ready for finishing

The difference between the ordinary welding process and autogenous welding lies in the fact that the smith heats the parts to be welded until they get soft and then unites them by hammering, whereas in autogenous welding the portions adjacent to the fracture are brought together and heated to their melting point. The principal point in autogenous welding, therefore, is to produce a temperature in which iron—or the material to be welded—melts. In this case only the portions to be welded may be heated in a very short space of time and the job may be finished ere the neighboring portions begin to heat up. For this reason a very small acetylene flame may be used, this producing a high enough temperature over a small range.

The high conductivity of metals would not permit the flame to get hot enough to melt them if it were left to the flame suction to supply the air necessary to produce the high temperature above mentioned. For this reason compressed air, or rather oxygen, is led into the acetylene flame, causing a flame similar to that of the blow-torch. Oxygen is applied in preference to compressed air, since, if the latter is used, the 80 per cent, nitrogen contained in the air must be heated at the expense of the energy content of acetylene and oxygen. The best possible effect is obtained by mixing the two gases in a mixing chamber.



Executing an autogenous-welding job on an automobile. Two men handle a flame each and another assists

It may seem quite remarkable that this very explosive mixture of acetylene and oxygen does not fire back into the gas lead, which would result very seriously. The same point may be raised in connection with the use of a gasoline blow-torch. But the reason why this never happens is easily found. To make it possible for the flame to backfire into and ignite the mixture in the gas lead the velocity of the burning gases would have to be in excess of the speed with which the mixture is forced out of the nozzle. To avoid this the nozzle aperture is made so small that, together with the pressure of the mixture in the gas line, it fully balances the tendency of the flame to backfire. In addition to this, copper gauze screens are inserted in the gas pipe, so that should a flame find its way into the interior of the pipe it would instantly be cooled and extinguished.

The principle of autogenous welding seems to be simple enough, but the work is not so very easy, because the process requires more than that the fractured pieces be melted and pressed together. The repaired portion needs to be quite as strong as it was before fracture, or it will not be able to sustain the stresses imposed upon it. But the high temperature to which the metal is submitted may bring about some change or other in its chemical composition or structure, and therefore some skill is required to obtain the desired result.

Besides acetylene only hydrogen has been practically considered so far for the purposes of autogenous welding. But, at the present high prices of power, hydrogen cannot be produced as cheaply as acetylene, and it is troublesome to transport. The most common way of producing hydrogen is by treating zinc shavings with dilute sulphuric acid. Only recently a compound named hydrone has been placed on the market which, if it is brought into contact with water, develops hydrogen as carbide develops acetylene. This material seems to offer some possibilities of a more general use of hydrogen.

While it is acknowledged that hydrogen is still more combustible and therefore more dangerous than acetylene, the oxy-hydrogen flame utilizing a similar apparatus as the acetylene autogenous process has been perfected to practical usefulness. The same flame offers also great possibilities in respect to illumination. Limelight, so eagerly striven after by many, is produced by the point of an oxy-hydrogen flame heating a pivot of lime. The possibility of an adaptation of limelight illumination for automobile use is by no means a small one, and the system producing a limelight on as safe a basis as acetylene illumination stands on to-day, would no doubt find numerous motorists ready to adopt it.



# Digest of the Leading Foreign Papers

THE French Society for the Prevention of Accidents to Workmen instituted a

## Safety Starting Cranks--II.

competition this year for designers of safety cranks, with a view to standardizing a method for avoiding the accidents now frequently caused by the involuntary reversal of a crank's direction of rotation, especially in the starting of automobiles and in the use of winches and hoisting apparatus. Three of the cranks submitted in this competition were described and illustrated in THE AUTOMOBILE of October 26. Three more are described here-with and illustrated in Figs. 1, 2 and 3.

In the crank designed by V. Morland the extension motor shaft is grooved at the end, and the keypiece B (consisting of the keypiece proper and a square shank with dog C), which is inserted in the back of the crank, engages the groove and carries the crank along when the position of the lockpiece D is such as to permit the spring R to press the keypiece home. To regulate the position of D it is provided with a stubshaft carrying a pawl which, in conjunction with the stationary ratchet wheel G (which is fixed upon a sleeve in which the motor shaft extension rotates), prevents D from following when the crank is rotated in the wrong direction. By a very slight movement of the crank in the wrong direction the cam groove in D consequently throws the dog C upward, against the resistance of spring R, and, as C is part of keypiece B, thereby at the same time releases the crank from the motor shaft. In the drawing, Fig. 1, the cross-section taken along dotted line *aa* is seen from the motor side, and the pawl is shown in dotted lines. It is seen that not only the reversal of the motor shaft, but the reversal of the crank as well, releases the latter, and this feature enables the operator to place the crank in the suitable "twenty-five minutes to" position for a starting movement in every instance. (The description and also the drawing of the Morland crank, as given in *Bulletin Officiel*, seem inconsistent with true mechanics at several points, and both have here been modified somewhat, so as to represent the principle of the crank correctly, as it must be.)

A crank designed by Louis Royer consists of a crankhub 1, 2, 3, 4, of which 1 is smoothly cylindrical and forms the bearing for a sleeve A provided with the customary clutch arrangement for gripping the motor shaft and at its front end formed with a conical surface K. Part 2 is formed with a square thread of steep pitch engaging a correspondingly threaded sleeve formed exteriorly as a ratchet wheel and provided at its rear end with a conical surface F adapted to form a clutch with the hollow cone K. Part 3 is screw-threaded to secure the flanged nut D, which serves as abutment for spring C, the latter exerting a

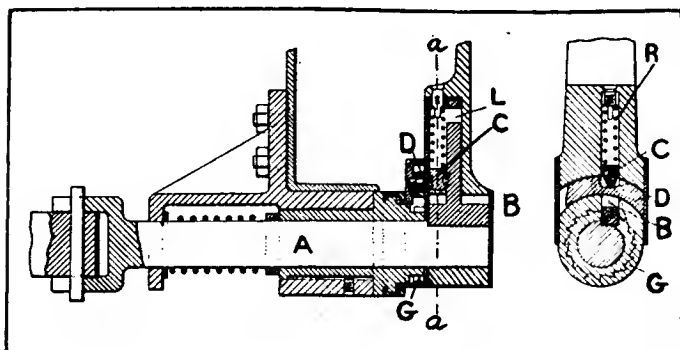

Fig. 1—The Morland safety crank, longitudinal section and cross-section on line *aa*.

pressure upon the end of the ratchet sleeve, acting through the medium of a ball bearing. To part 4 the crank handle M is secured. The crank is shown in the drawing as one to be turned "against the clock" for starting the motor. The combined pawl and lock bolt T, when let down upon the ratchet sleeve behind the ratchet teeth, prevents any engagement of the crankhub with the motor shaft. To start the motor T is raised by hand and dropped into engagement with the ratchet teeth, the crank mechanism being at the same time shoved back, against the resistance of spring U, to engage the motor shaft. When the crank is turned in the right direction the thread of part 2 forces the ratchet sleeve into driving engagement with the sleeve A, while T, now acting as pawl, slips over the ratchet teeth. If the motor shaft is turned in the opposite direction,

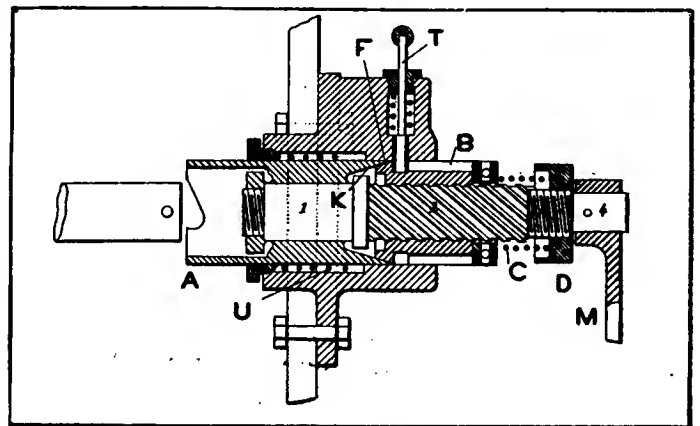

Fig. 2—The Louis Royer safety starting crank

any incipient reverse movement of the crankhub makes the pawl stop the ratchet sleeve, while the action of the steep thread draws the conical surfaces apart and releases the crank mechanism, excepting sleeve A. (It seems, however, that pawl T may be in a position in immediate proximity to the stop face of a ratchet tooth, when the reverse action begins, which will leave scant chance for any rotary action to release the cone clutch.) The spring C is intended for pressing the ratchet sleeve forward on the steep thread sufficiently for avoiding lost motion in bringing the cone clutch into engagement, but not sufficiently for a working engagement.

The Duperron crank is of pleasing simplicity. To get the clutch B in engagement with the motor shaft A at the pin D, the pin G on the crank axle must engage sleeve E, which carries a ratchet wheel R, upon which acts pawl F, itself pivoted in the fixed plate S secured to the chassis. If the motor kicks back, the ratchet wheel is stopped by the pawl and the oblique edge in the clutch notch of sleeve E throws the crank out of engagement with the motor shaft. To make sure, the notch in E is deeper than that (or those) in B.

In the competitive trials of the cranks, prizes of 300 francs each were awarded for the Clemencet, the Duperron and the Morland cranks, but none of them was considered all that could be desired. Honorable mention was accorded for the other cranks here described.—From *Bulletin Officiel*, September.

FORCE-FEED SPLASH OILING FOR CHEAP CARS—The system has been tried out during the past two years and found good. The lower part of the sump (which is the rather expressive term

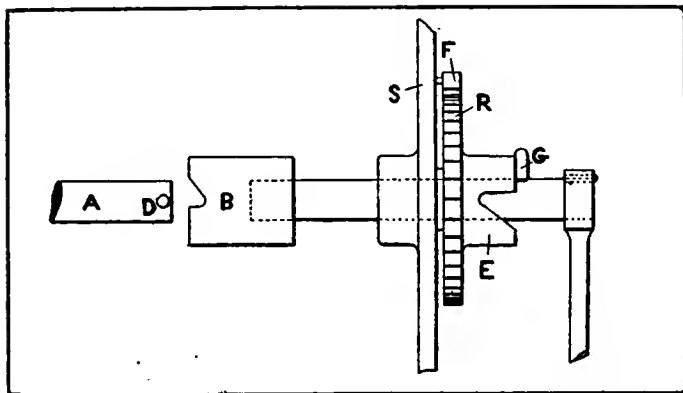

Fig. 3—Side View of Duperron Safety Starting Crank

used in Great Britain for the lower half of the crankcase) forms the oil reservoir, and at the bottom of it a pump is mounted horizontally and driven by a worm machined upon the camshaft, which meshes with a helicoidal gear upon the pump body. The pump drives the oil through a tube to a collector, from which it is distributed under the pump pressure to the crankshaft and camshaft bearings. Under each of the connecting rods there is formed a saucer into which drains the surplus oil from the crankshaft oil channels, and each connecting-rod knuckle carries a little cup which dips into the corresponding saucer at the bottom of the stroke, picking up a determined quantity, which rises to the connecting-rod bushing through holes provided for this purpose. With an ample discharge from the pump, the system evidently has the advantage of a constant level splash feed, being independent of the oil level until the same gets so low as to rob the pump of its supply, and it seems to have the additional virtue of being sparing in the quantity of oil which it sends to the cylinder walls and to the piston pin.

An oil-circulation indicator on the dash secures the pump supply.—From description of La Buire car in *La Pratique Automobile*, October 25.

**WIRE AND WOOD WHEELS**—The superior strength, at equal weights, of the wire wheel over the wood wheel does not depend, according to the Rudge-Whitworth company—whose detachable wire wheels are gaining much ground in Europe—upon the intrinsic properties of steel in comparison with other materials on a weight basis, but almost solely upon the fact that the steel, with its much higher density, takes up much less space for a given strength and therefore may be applied to the suspension design of wheels which, on the other hand, is impracticable with the more bulky materials. The suspension wheel, in which the rim is in compression and the many spokes in tension, is a far more efficient design, says the firm, than the artillery wheel in which the relatively few spokes are in compression and subject to bending strains and the rim is in tension. Owing to the crossing of spokes and the very large joints which would be required, a wood wheel built on the suspension principle would be ten times as broad as a wire-spoked suspension wheel of the same load carrying capacity. The point in understanding raised by the firm is illustrated in the accompanying table.

STRENGTH IN POUNDS OF WHEEL MATERIALS.

	Weight of one cubic foot.	Elastic limit, pounds per square inch.	Tensile strength, pounds per square inch.	Breaking pull of piece 1 foot long weighing 1 pound.	Elastic limit of piece 1 foot weighing 1 pound.
Steel spokes.....	490	135,000	157,000	46,140	39,680
Aluminum, 97½ per cent. alloy rolled....	170	15,000	26,000	22,030	12,710
Hickory, American average.....	50	11,200	19,600	56,450	32,250
Ash, American.....	39	7,900	17,000	62,760	29,170
Oak, white.....	50	9,600	13,600	39,170	27,650

—From *The Car*, October 15.

## Harking Back a Decade

**F**ROM *The Motor Review* November 21, 1901: Henri Fournier is planning to establish a factory in the United States to make a racing machine under patents of his own. The capital is said to have been promised by Foxhall Keene and other New York millionaires.

The withdrawal of the Apperson brothers from the Haynes-Apperson Company means that an entirely new type of automobile for four passengers and equipped with tonneaus exclusively will be made by the former.

The I. A. Weston Company, of Syracuse, N. Y., has purchased the entire plant of the Jamesville Manufacturing Company and will make automobile axles and other steel parts for motor cars and horse-drawn vehicles.

At the coming South Carolina and West Indies Exposition, which opens at Charleston December 1, there will be a large display of automobiles. The Wagener Driving Park course will be used for motor racing and demonstration.

The H. H. Franklin Manufacturing Company, of Syracuse, will be reincorporated shortly with an increase in capitalization from \$100,000 to \$250,000. It is intended to commence the manufacture of motor vehicles at once.

As was done at the New York automobile show, the track at the Coliseum, Chicago, will be abandoned this year. The pressure for space was so strong that the 7,000 square feet formerly used for a track will be divided into show spaces.

Alden L. McMurtry, with his new 16-horsepower Packard, weighing 3,600 pounds, recently climbed the Buena Vista street hill in Pittsburgh, a feat never accomplished heretofore with a motor vehicle.

The Knox Automobile Company announces that it took enough orders at the recent show to keep the factory busy for a month. Next week, it is announced, day and night shifts will be installed to fill orders and prepare stock for next summer.

Constant Huret, a well-known French chauffeur, has been arrested in Paris for abducting a gendarme and exceeding the speed limit. It appears that M. Huret stopped his automobile in the Bois de Boulogne and an officer stepped aboard to caution him about speeding. Huret dropped in his clutch and carried the minion of the French law several miles before obeying his orders to go to the police station.

Henri Fournier, driving a Mors racer, broke the world's mile straightaway record last week on the Ocean Parkway, Long Island, making the distance in 51.45 seconds. This is 5.15 seconds faster than the best time ever made for that distance even in France. The circular track mile record made by Alexander Winton in a Winton still stands at 1:06.2-5.

The timing was done by stretching a rubber hose across the starting line. Inside the hose were two strips of copper and the passage of a contesting car was supposed to press the two copper surfaces together, thus closing an electrical circuit. The impulse given by this was intended to convey a flash to the finishing line. On paper it seemed reasonable, but in practice it failed dismally.—*Editorial*.

The Stearns Steam Carriage Company, of Syracuse, announces that it is putting out twenty-five more traps of the latest design. These cars are equipped with a new gasoline generator which makes possible the use of a low-grade gasoline and will generate 150 pounds of steam from cold water in 10 minutes.

# Letters Answered and Discussed

## Adjusting Worn Valves

EDITOR THE AUTOMOBILE:

[2,917]—I have had the valves on my car ground often, taking it altogether, as my car is very old. I am sure that the valve timing has become affected owing to the number of times this has been done. Is there any way of com-

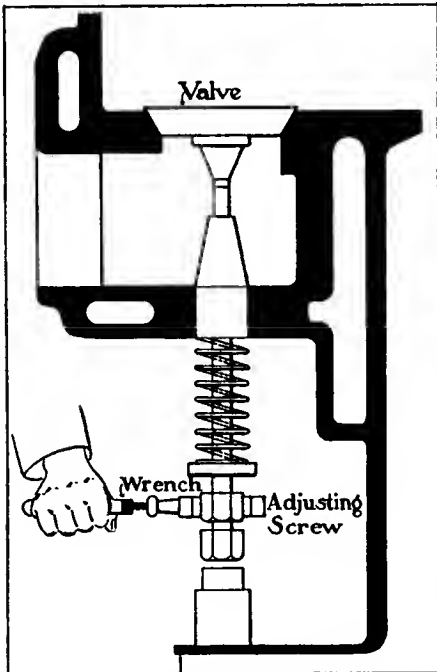

Fig. 1—Showing method of making adjustments on worn valves

pensating for this change in the valve position?

J. R. C.

White Plains, N. Y.

In grinding down the valves the total strength is decreased by the amount that the depth of the valve is reduced by the grinding. This may be compensated for by making the adjustment shown in Fig. 1. The nut shown is turned and the length of the stem increased.

## Leave Breather Pipe Open

EDITOR THE AUTOMOBILE:

[2,918]—Will you kindly answer the following queries through the columns of your paper:

(1) Is there any chemical less expensive and with which there is less evaporation than alcohol, which might be put in the radiator to prevent freezing?

(2) I have fitted a funnel with a tight lid on it to the breather pipe opening of my four-cylinder motor in order to keep the dirt out and for convenience in pour-

The Editor invites subscribers to communicate their automobile troubles and personal experiences, stating them clearly on one side of the paper. If the nature of the case permits, send a sketch, even if it be rough, in order to assist to a clearer understanding. Each communication will receive attention in the order of its receipt, if the writer's signature and address accompany it as an evidence of good faith. If the writer objects to the publication of his name, he may add a nom de plume.

ing in oil. Should this breather pipe be left open for any reason?

E. C. N.

Juniata, Pa.

(1) Glycerine is used extensively to make an anti-freezing solution. The proper amount of it to add to the cooling water should be determined by the local weather conditions. The following table gives the freezing points of glycerine solutions:

10 per cent. glycerine freezes at	30 degrees F.
20 per cent. glycerine freezes at	27 degrees F.
30 per cent. glycerine freezes at	21 degrees F.
40 per cent. glycerine freezes at	0 degrees F.
50 per cent. glycerine freezes at	-25 degrees F.

(2) The function of the breather pipe is to relieve any compression which may be produced in the crankcase, and obviously it should not be closed. The end of this pipe is usually covered with a wire gauze to prevent dirt from getting into the crankcase, and if you put oil into the latter through this pipe, you can fit a funnel to it which has a strainer inside.

## Testing Magneto with Bell

EDITOR THE AUTOMOBILE:

[2,919]—I would greatly appreciate it if you could give me a little information on the ignition system of my Ford Model T car. I wish to test the coils and would like to use a common magneto bell such as I use for testing for grounds and open circuits in electric lines.

If the coils are in good order, how should they act in connection with the magneto bell and how should the same be connected to the coils?

J. L.

Mellen, Wis.

The bell may be readily used to test the magneto coils. The manner in which it should be connected is as follows: Remove the contact spring and place one end of bell circuit at contact point and the other on different parts of the engine frame, which is grounded; if the bell rings, the coil is all right insofar as the wire therein is concerned, and will then have to be tested for short circuit. This test is made by removing the magnetic field and coils and connecting the bell circuit to the contact point and then to the plate

by means of which the circuit is grounded to the engine frame. If the bell rings when contact is made, there is a short circuit in existence which will have to be found and eliminated.

## Misses When Speeded Up

EDITOR THE AUTOMOBILE:

[2,920]—I am very much troubled with my engine, which misfires when speeded up beyond 12 miles per hour on the high speed. I blamed the carburetor at first, but after cleaning and adjusting it and examining the whole gasoline line I am convinced that the trouble lies in the ignition system. At the same time I cannot see how it will work at low speeds and not at high. Can you help me out?

ALEXANDER CARROS.

Pueblo, N. M.

Examine the timer to see if it is worn, if not, your vibrator is not correctly adjusted. To remedy this, turn the screw on the outside of the coil box until the trembler gives a good clear humming sound at all speeds. The manner of making the adjustment is illustrated in Fig. 2.

## Regarding Reverse Ratio

EDITOR THE AUTOMOBILE:

[2,921]—Would like to have the question of reverse gear ratios aired a little. In

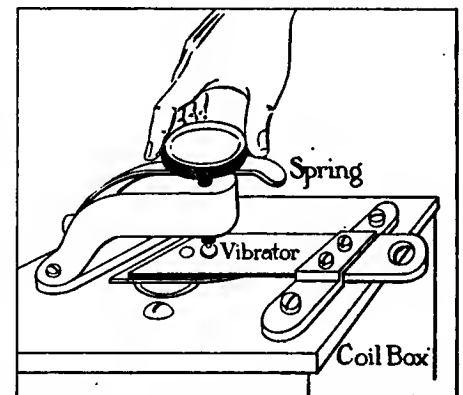

Fig. 2—A badly adjusted vibrator is often responsible for an elusive miss

several cases, if I am not mistaken, the reverse gear ratio is about the same as the intermediate ratio forward. Now I have always taken it for granted that the reverse should be even lower than the lowest forward speed to allow of the same turning effect to reach the rear wheels through the less efficient reverse gearing as through the low speeds forward, thus enabling the car to be maneuvered into or

out of any situation desired. I did not know there was any need of any higher speed in the reverse than the common ratio provided. A. D. KELLOG.

Eureka, Cal.

If there is any gasoline car manufactured whose reverse speed is higher than the lowest forward speed, it has not become known to us.

### Likes Kerosene Idea

Editor THE AUTOMOBILE:

[2,922]—Your answer to question 2895, issue of October 2, relative to using kerosene in the radiator of the automobile in place of water would seem to indicate that there would be no permanent injury to the cylinders or motor from the use of kerosene in place of water. Now if this be true, why not use kerosene in cold weather in place of alcohol when it is possible to purchase it for the small price of 6 or 7 cents per gallon, where alcohol is so much more expensive?

It seems to me that it would be much cheaper to use kerosene in cold weather unless there is some injurious result to offset the difference. Kindly give a little light on the subject and greatly oblige a constant reader of your magazine.

FRANK CONE.

Findlay, O.

So far as can be seen without actually trying the experiment there should be no deleterious effects arising from the use of kerosene beyond the fact that the engine would heat up, unless the weather were very cold, owing to the low specific heat of the kerosene. In a climate where the days are warm and the nights cold, as is often the case at this season of the year, kero-

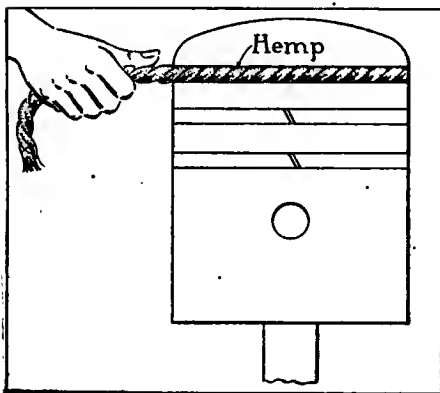

Fig. 3—The life of piston rings may be prolonged by the use of hemp

sene would probably not cool the engine as well as it should during the middle of the day.

The freezing point of kerosene is rather uncertain, and if you have experimented in this direction sufficiently to obtain definite and satisfactory results, the scheme you suggest may be tried with success in very cold weather. Kerosene will certainly not affect the metallic parts.

### Wants A. L. A. M. Formula

Editor THE AUTOMOBILE:

[2,923]—Would you kindly inform me the method used to rate the horsepower of gas engines given by the A. L. A. M.

RALPH G. HISSEY.

Cape Cottage, Me.

The A. L. A. M. formula is as follows:  
 $D^2 N$

— where D is the diameter of the cylinder and N is the number of cylinders.

### Using Worn Piston Rings

Editor THE AUTOMOBILE:

[2,924]—I believe I read somewhere that it would be possible to use worn piston rings for a time by inserting something beneath them to hold them out. Could you tell me how this is done?

OLD SUBSCRIBER.

Tenafly, N. J.

It has been done by inserting a small winding of hemp twine in the ring aperture. The winding of hemp is placed in the groove as shown in Fig. 3 and the ring placed back over it. The ends of the ring will be spread a little farther apart than formerly as seen in Fig. 4. This will hold for several months if properly done.

### Has Elusive Misfire

Editor THE AUTOMOBILE:

[2,925]—I have a 40-horsepower car which I have driven until recently without experiencing any ignition troubles. Now, however, the engine has started misfiring. I have ground in all the valves, both intake and exhaust, and have had the cylinders off and cleaned the carbon out but without effect. The wiring has also all been completely examined in the hopes of locating the miss, but without success. The motor does not seem to misfire so much when running light and in the first and second speeds, but as soon as I go into high it will miss considerably.

At other times, when in high speed it will run 20 miles without a single miss. I am using dry batteries for ignition purposes, six cells connected in series. I am sure it is not due to the batteries, however, as the same thing occurs when I am using new batteries. Anything you may suggest which might help will be greatly appreciated by me.

L. P. BEERY.

Thurston, O.

An elusive misfire is often due to the fact that the rotor of the timer has become loose on its shaft and changes its relative position. The misfiring is often accompanied by preignition and backfiring when this is the cause of the trouble. The spark plug may be sooty. Induction coil troubles are often responsible for just such a condition; there may be dirt between the contact points, the contact points may be loose, the connections with-

in the coil box may be loose or the insulation within the coil box may be defective. The timer is often unsuspected when it is the seat of trouble; for instance, the contact points may be dirty, bad contact on account of worn or dirty parts may be found, or the shaft may not have good contact with the metal of the motor owing to the presence of a film of grease which partially insulates the shaft.

The battery cells will often shake about in such a manner that the electric connections between them are severed or at least rendered very uncertain. In this

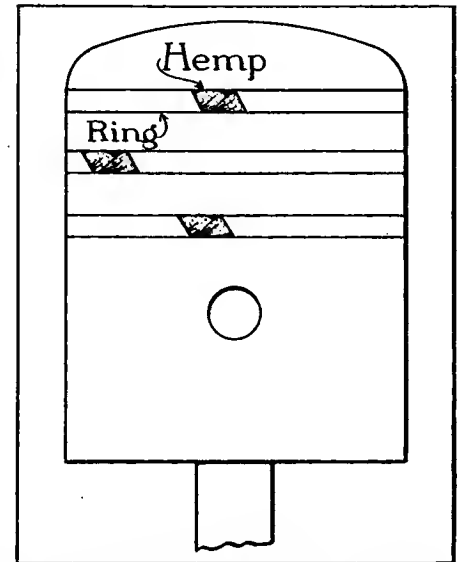

Fig. 4—Showing the appearance of the piston after the hemp is inserted

case it often happens that an irregular misfire is often developed. It is in this latter that the source of trouble will most likely be found. If these fail, carefully examine the carbureter for dirt.

### Query About Carbureters

Editor THE AUTOMOBILE:

[2,926]—I have a 25-horsepower car, and it may be all right, but I cannot help tinkering with the carbureter, which does not seem to be capable of giving satisfaction. I have had the obstinate thing treated by a repairman, but this has made things no better, and I am tired of it.

I have heard about several types of automatic carbureters, and I understand that these have a fixed nozzle opening, thus protecting the most delicate portion of the workings of the driver. Where can I get a description of an up-to-date automatic carbureter?

Port Jervis, N. Y. WM. J. NUTTY.

On p. 822 of the issue of Nov. 9 is described an automatic type of carbureter, in which a fixed gasoline inlet is used, while the air supply varies with the demand of the motor. Another type of automatic carbureter was described in THE AUTOMOBILE of August 17.

# Little Bits of Motor Wisdom

## Tools and Other Devices Useful to Repairman and Driver

**USING DIFFERENTIAL PULLEYS**—Few of the smaller garages and repair shops realize the importance of the pulley system illustrated in Fig. 1 as a labor saver. Its principal use, as far as the repairman is concerned, is in connection with the removal of the motor from the chassis. Every garage should have a special place for such work to be done, and a heavy wrought iron hook or loop should be securely fastened in the ceiling at this point for the purpose of suspending the pulleys. When the nature of the repair necessitates the taking down of the motor, the car should be run to this particular part of the shop, and after taking out the holding bolts and other connections with the body of the machine, the differential pulleys should be brought into play to lift the motor onto the "horse" or bench provided for the purpose.

A good form of motor "horse," and one which is used by some of the larger repair shops, has two small wheels fixed to two of its legs, with handles at the

other end. After placing a motor on it, it is wheeled to a lighter and more convenient place. In making the finer motor adjustments it is advisable to have as much daylight as possible, since better results can be expected from the mechanic who has a light and properly ventilated place to work. Very often a dull, besmeared incandescent lamp furnishes the only light the workman has at his command, and small wonder is it that with such facilities a motor which calls for accurate repair frequently leaves the shop practically in worse shape than when it entered.

**NUT LOCKING DEVICES.**—Most motorists are familiar with the various methods in vogue for securing nuts on their bolt-ends so that the jarring and vibration to which they are subjected will not cause them to work loose or be lost. Sometimes two nuts are used, jamming against one another and locking in this way, the smaller or check nut being placed under the thicker regular one. This is not so good as the use of cotter pins, which are put through holes drilled in the ends of the bolts, and their ends spread to prevent their slipping out. This fastening prevents the loss of the nut, but does not do away with its tendency to turn.

Castellated nuts are used extensively for automobile work, and they afford the best method of fastening, since turning and loosening are both prevented. Fig. 2 shows the nut A with the cotter-pin C passing through the end of the bolt B. Diagonal slots are cut in the top of the nut, and the cotter rests in one of them. Of course, one of the slots must register with the drilled hole in the end of the bolt before the cotter can be put in place. Whenever possible, it is best to use this form of fastening.

**REQUIREMENTS OF A GOOD CLUTCH.**—The life of a car is entirely in the hands of its driver. To prolong the life of the car is or should be the object of every driver, and to do this few things are so important as the proper manipulation of the clutch. A clutch should engage gradually; that is, it should not take up with a jerk, but should impart the motion of the motor to the car gradually, so that there are no undue strains upon the driving mechanism. It often happens also with a fierce clutch that the weight of the car is suddenly thrown upon the engine while it is running slowly, and the inertia is sufficient to stop the

motor. A feature of a good clutch which may be said to be second in importance after gradual engagement is that it should disengage almost instantaneously so that there will be no drag.

The clutch generally performs its work by friction, hence a large surface is a beneficial feature inasmuch as the friction depends directly upon the area of contact between the surfaces. It is evident that if the surface is not large enough the clutch will slip, or, if it does not slip, a greater strain will be put on each unit of its sur-

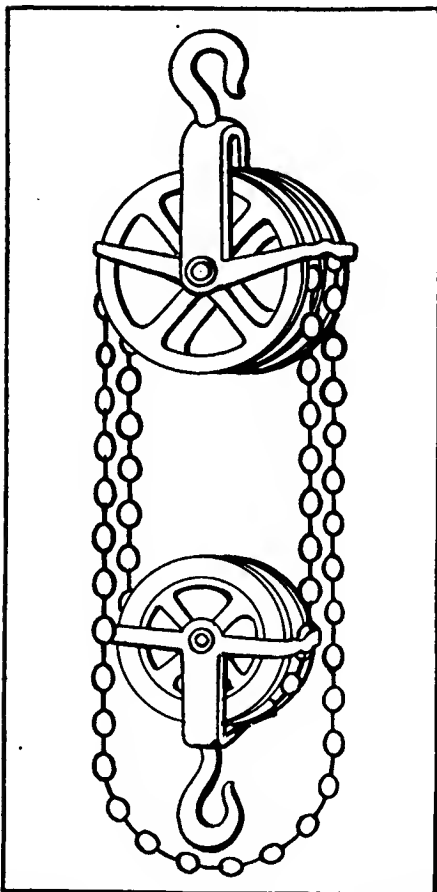

Fig. 1—Differential pulleys for lifting motors and other heavy parts

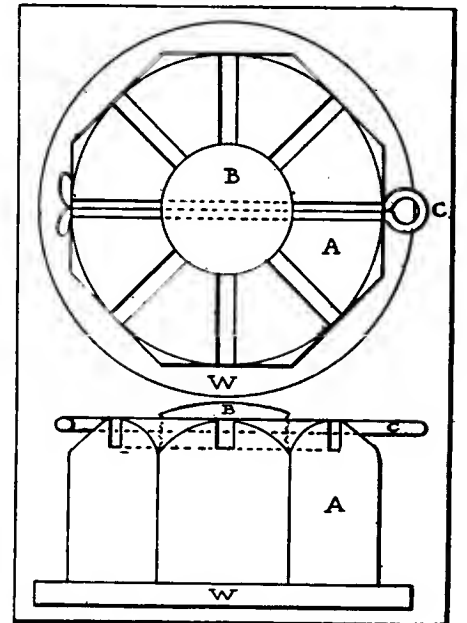

Fig. 2—Castellated nut with cotter-pin in place

face and the life will be much shortened.

The other requirements of a good clutch are the same as those of any piece of mechanism; that is, it should be capable of being inspected for wear or other defects in as simple a manner as possible. It should also be capable of adjustment so that if a slight amount of wear has taken place it will not be necessary to purchase an entirely new part, but that compensation may be made for any wear that does take place. The clutch should be simply and substantially constructed so that there is as little to get out of order as possible.

The friction member is sure to need replacement after the clutch has been in use for some time, and for this reason it should be placed upon the clutch in such a manner that it is very readily removed and re-fitted without disturbing any of the other parts. These requirements are for any of the friction clutches.



**PLIERS OF DIFFERENT TYPES.**—There are few who have not some type of wire pliers in the tool kit of their machine. It is doubtless well known that these tools are made in different styles to suit the different purposes for which pliers are used. In Fig. 3 are illustrated four different types of pliers which are of use to the automobilist who finds it necessary at times to perform some work about the electric wiring on his car.

The type numbered 1 in the illustration is about as familiar as any of the varieties of this most useful tool, and is so shaped that it is possible to obtain a firm hold upon the wire and at the same time, if so desired, the wire may be bent back and forth with pliers so that it is broken off at the edge of the tool. If it is desired to coil the wire for a short distance the wire is held in the pliers and they are turned around in the hand. This will produce a spiral in the wire.

The pliers shown at 2 are of entirely different shape, being so arranged that the wire will pass through the corrugated opening. The corrugations are arranged at such a distance apart that when the pliers are closed over the wire a very firm bite will result. In case it is desired to break the wire, all that is necessary to do is to take hold of the wire with the end of the pliers instead of simply allowing the wire to pass through the corrugated teeth. The wire is then bent back and forth in the same manner as described for the flat pliers. A form of the tool somewhat similar to the type shown at 2 is illustrated at 3, the difference lying mainly in the blunt end.

The corrugations are also a feature of the pliers illustrated at 4; in this case, however, there are two sets of teeth to allow of the pliers being used with different sizes of wire. To break the wire the process is the same, consisting of seizing the wire in the end of the pliers and bending it until the break is made. If one of these varieties is chosen to have

a place in the repair kit it will be sufficient, as any of the types may be used with entire satisfaction, although a combined cutter and plier would be even better.

**HEADS OF DIFFERENT SHAPE.**—Bolts, studs and screws are made with heads of different shape to accommodate them to the various usages to which they are to be put. In choosing the head required for

which is slightly too large, to spoil it to such an extent that it is exceedingly difficult to remove it at all. It is a great mistake to attempt to remove a nut with an over-sized wrench, since it is always possible, by the insertion of a flat piece of metal between the wrench and the nut to secure the same turning effect as if the wrench were the correct size, and at the same time none of the evils of a wrench which is too large are felt.

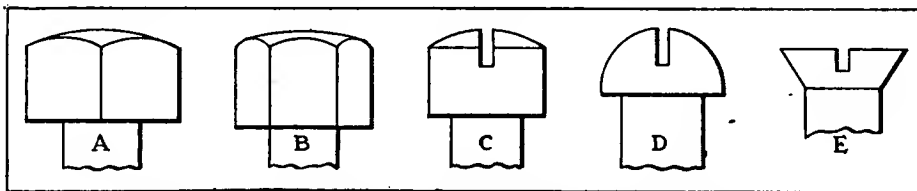

Fig. 4—Bolt, stud and screw heads are of various forms for different purposes

different purposes, strength, weight, cost and appearance are all factors, but the governing feature which should determine the matter lies in the requirement of accessibility and convenience. There are many places about an automobile engine, for instance, where it is impossible to go with a wrench and yet a screwdriver could reach the desired spot very easily. In many cases of this kind where a bolt has been made use of, a slot can be put in the head to take the screwdriver should it suit the convenience of the operator.

In Fig. 4 are shown five different types of heads used in connection with bolts, studs and screws. These five different types offer a wide enough choice to fulfill the requirements for convenience and appearance in any circumstances which may arise.

The head shown at A is square and may be used in connection with either a through-bolt or a stud. It has the advantage that the wrench is not prone to slip around it and wear the nut into a circle. This advantage is particularly felt in the smaller sizes of nuts where it is possible, by attempting to turn the nut with a wrench

The hexagonal head is shown at B, and is common enough to need but few words to describe it. It has the great advantage that it is always turned in such a manner that it is possible to put the wrench over it to either tighten or loosen it. This advantage is not always possessed by the square head, as this may be turned in such a way that it is impossible to reach it with a wrench owing to the cramped surroundings. In such cases, however, even the hexagonal head will be found rather difficult to get at and the swings which can be made with the wrench will be so small that the operation of turning the nut will be both arduous and long.

It is in a case of the latter kind that the flat-headed machine screw is called into use, that is if the size of the stud be not over 1/2 inch. Where this head is used it is generally found that the metal is countersunk so that the head of the screw is just flush with the outside of the metal. This serves to give a neat appearance and a very workmanlike job. A screwdriver is a much better instrument for reaching inaccessible spots than is a wrench of any type, and it is for this reason that these screws should be used where the space prohibits the convenient use of nuts.

Where the head of the screw is to remain outside the surface of the metal, that is in cases where a countersunk head is not permissible, a better appearance is given the work by employing the round-headed screw as shown at D. The difference between this and the countersunk head screw lies merely in the appearance, the usages being the same. The head shown in the illustration at E is used almost entirely for wood-working operations. The countersink is for the purpose of improving the appearance of the finished work. In very fine work where the best possible appearance is made an aim the countersink is made extra deep so that the screws may be sunk considerably below the surface level, and then a plug of wood similar to the rest of the work is placed over it.

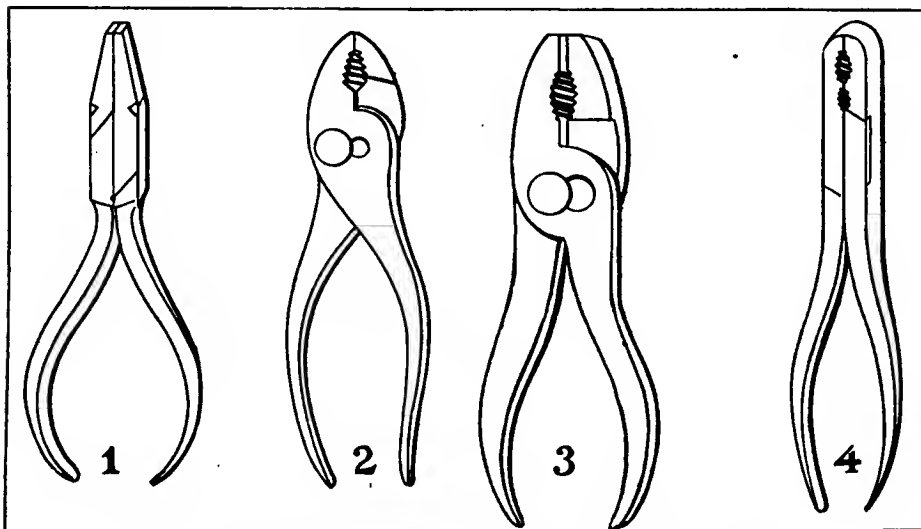

Fig. 3—Illustrating four typical varieties of pliers found in common use

# My Best Automobile Repair

## Some Quick Repairs Made in the Garage and on the Road

### Using Old Casings

**EDITOR THE AUTOMOBILE:**

When the ordinary automobile tire has pounded, skidded and ground over about 3,000 miles of common roads its condition insures an almost endless run of trouble and expense. The tire does not seem so badly worn that one feels justified in throwing it away, yet the frequent repairs together with the number of ruined inner tubes, and the consequent damage to one's moral character, certainly make it a paying proposition.

There is one way to get one-half as much more wear out of such casings without any expense to speak of. But in order to do this the plan which I am about to describe must be followed to the letter or results will not be satisfactory.

The plan consists in using one partially worn casing for a tread for another worn casing of the same size.

The casing which has the least rim cuts and injury near the beads should be selected for the inner one, and the one with the best tread should be selected for the outer.

If there are any breaks or holes in the

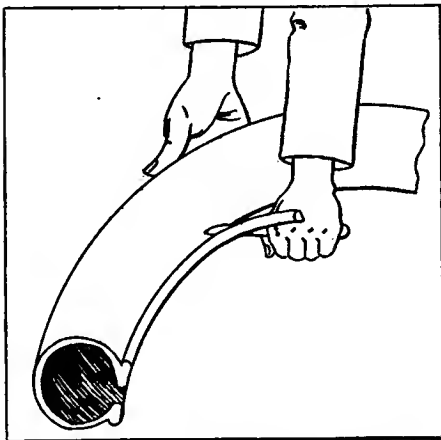

Fig. 1.—Depicting the operation of cutting the bead from the tire casing

fabric of the casing which is to be attached to the rim, they should be fairly well re-inforced with rubberized canvas inside patches, so as to offer a smooth surface to the inner tube.

The outside of this casing should then be well cleaned with gasolene, using an ordinary scrubbing brush and soft cloth for the work.

The old casing to be used for a tread should then be cleaned with gasolene on the inside, and the beads be cut off with a sharp knife.

*Temporary automobile repairs made by the driver or owner while on the road and permanent repairs made in the garage after the run is over, are interesting to all automobile owners.*

*It may be a spring leaf has broken; a shackle bolt or strap may break; a steering tie rod is bent; the car skids into a curb and bends a steering arm or the starting crank; a throttle or magneta connection breaks owing to vibration; a radiator leak is started by a stone or some other means; a leak in the gasoline tank is discovered; there is a small hole in the gasoline feed line; a brake facing may burn out; a brake connection breaks; a front axle gets slightly sprung; a clutch starts slipping, or any one of a thousand things may happen.*

*Every automobile owner is interested in knowing how repairs have been made, how long it took to make them, how much they cost, and by whom they were made.*

*We want you to write in simple language in a letter what repair of this nature you have had to make, how you made it, how long it took you and how much it cost.*

*You can make with your lead pencil one or two rough sketches indicating the broken or damaged part and showing how the repair was made.*

*The experience of each reader is interesting to every other reader. Analyse your past experiences and send in one or two of them.*

*Give your name and address, legibly written. If you do not want your name to appear, make use of a nom de plume.*

**Editor THE AUTOMOBILE.**

With the other casing on the rim, but deflated, the tread casing is worked on over the surface, using an ordinary tire tool as a lever.

After it has been adjusted evenly in place, vulcanizing cement, in quantities of about one teaspoonful for each place, should be poured between the casings opposite every second spoke of the wheel, and with the fingers inserted between the casings; the cement should be distributed for some little distance each way.

The tire should then be pumped up to proper capacity and left unused for twelve hours to dry.

An old casing with the beads removed will have just enough elastic give to its fabric to afford a snug and supporting fit for another casing of the same dimensions with the beads retained. The tread thus applied will cost practically nothing, and will give a resistance to road wear that will fully equal half the value of a new tire.

It makes a particularly good tire for Winter use, as the tread is wider and flatter than a new tire.

It is less liable to ordinary puncture than a new tire, as it is almost double the thickness on the tread.

A good plan is to get new tires of 1-2-inch extra diameter for rear wheels, and use the old rear casings to re-tread the front tires.

In the Winter, when repairing tires and tubes on the road is anything but pleasant, this arrangement gives satisfactory results.

One thing should be remembered in connection with old casings. The beads, whether clincher or Dunlop style, stretch a little in use, and the effect is to render "pinching" of the inner tube much more frequent than with new tires. This fact calls for greater care in having good protecting strips between the tube and rim.

An old inner tube which has been slit around its periphery and the valve removed will make a first-class protecting strip to prevent pinching.

The life length of a casing depends largely upon the firm adhesion of the fabrics to each other. When a tire is run not properly inflated the hinge-like bending of the fabrics is much greater than when pumped up to the proper pressure, and this constant bending tends to separate the fabrics and weaken the casing.

A little careful observation will enable a driver to tell at once when a tire goes

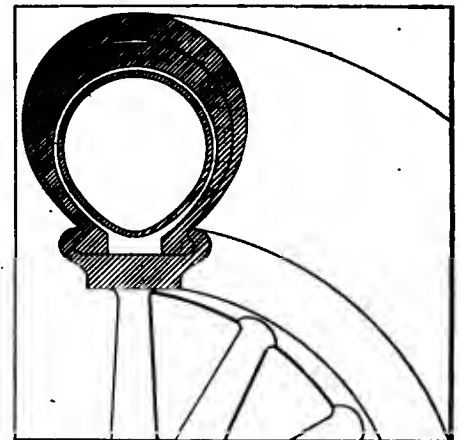

Fig. 2—The old casing A is fitted over the casing B in this manner

flat. And running on flat tires is very expensive.

The level of the front of the car will vary when one of the front tires deflates, and there will be a loss of speed when the rear tire lets go. If particular attention is given to these two ideas any careful driver will soon be able to stop his car immediately the tire goes flat on any wheel, and much expensive destruction of casings and inner tubes be avoided.

A. D. HARD, M. A.

Marshall, Minn.

# My Ideal 1912 Automobile

## Readers' Conceptions of What Next Year's Car Should Be

### Ideal a Lively Roadster

EDITOR THE AUTOMOBILE:

My ideal car for next year is a roadster that would have to step some.

The motor would be four-cylinder, four-cycle, with the cylinders cast in pairs, and it would have a bore of 5 3-4 inches and a stroke of 8 inches. The cylinders would be of the T-head type with the valves on opposite sides, and they would be 3 1-4 inches in diameter at the bottom. The motor would have three large bearings, and the clutch would be of the large diameter cone type. The transmission would have four speeds ahead and reverse, with direct drive on third speed, and would be geared 1 1-2 to 1.

I would prefer a shaft to a chain drive, even in a car of this size. The rear axle would be a full floating type, and the brake drums would be about 14 inches in diameter with 4-inch faces. The car would have an underslung frame, with 36-inch wheels carrying 5 1-2-inch tires.

The engine would be equipped with a Remy magneto and a Schebler carbureter, and it would have an auxiliary air pump. The gasoline tank would be placed on the back along with the oil tank.

This car, with 124-inch wheelbase, equipped with glass front, speedometer and hand oil pump, ought to sell for \$3000.

L. E. HOWE.

Liberty, Ind.

### Wants Long Stroke Motor

EDITOR THE AUTOMOBILE:

The specifications of my ideal of a motor car should be as follows: Cylinder bore, 4 1-2 inches; stroke, 6 inches; six cylinders; four ball bearing crankshaft; cam shaft on left with four ball bearings; intake valve in the head; exhaust valve on left side; intake manifold at right side, water-jacketed; Rayfield carbureter with dash adjustment; force-feed oiling by gear pump with reservoir in the bottom of the crankcase; Bosch dual ignition system; honeycomb radiator with centrifugal pump; gasoline feed by gravity; self-starter using compressed air, with tank (which should also be used for filling tires) underneath the car; multiple-disc clutch, having 26 saw steel driving plates and 25 bronze driven plates, running in a bath of oil, four-speed transmission on roller bearings, with reverse; flywheel, clutch, transmission and motor in unit; rear axle of the full floating type on roller bearings; one

*Readers continue to demonstrate their interest in the ideal car and the specifications which are submitted show a wide range of taste and requirements. In view of the interest shown the Editor continues to extend the invitation to all who entertain ideas on this absorbing topic, to submit their opinions for publication. The description should be legibly written on one side of the paper and signed by the sender, although if it is so desired the name will not be published.*

universal joint back of the transmission, and another in front of the rear axle; front axle to be of I-beam construction, drop forged in one piece, and on roller bearings; cross rod behind the axle; steering gear of worm and wheel type, with spark and throttle levers at top of an 18-inch wheel; control levers at the right side; foot pedal at the right; clutch pedal at the left; button type accelerator; metal body, with wood frame; 10-inch upholstery; body of five-passenger torpedo type with cowl dash; control levers inside; 126-inch wheelbase; front wheels to have twelve spokes and rear to have fourteen, both 36 inches in diameter and to be made of second growth hickory; every other spoke of the rear wheels bolted to the brake drums; service brake to be internal expanding; 14 inches by 3 inches; emergency brake to be external contracting, 15 inches by 3 inches; both brakes to be lined with Thermoid; front springs to be semi-elliptic; rear springs to be three-quarter elliptic with grease cups at all bearings.

The accessories should include the following: Mohair top, windshield, Stewart speedometer, Gray and Davis electric lighting dynamo system, seat covers, trunk rack, quick-detachable demountable rims, battery and tool box on the left side, large enough to accommodate one inner tube, Klaxon horn, 36 x 4 tires, Truffault-Hartford shock absorbers.

The car as outlined should cost about \$3000.

CARL H. ANDREAS.

St. Louis, Mo.

### Has Criticisms to Offer.

EDITOR THE AUTOMOBILE:

I have read with intense interest the opinions of your readers regarding the specifications of the ideal car for the season of 1912. In my opinion the ideal car for any man is not governed so much by what he really thinks would be the best car which it is possible to construct, but would, on the contrary, be the best car which it is possible to build for the

amount of money that the particular person may happen to have at his disposal for the purpose of purchasing an automobile.

There are many minor refinements which, while they are not a necessity, still add to the ease of running of the car or to its appearance to some slight extent, while the cost of their application to the car is far beyond the benefit to be reaped from their installation. The matter of wheel sizes is one of these cases where a large increase in cost arises from a slight increase in size; still every one is ready to admit the advantages of wheels of large diameter. Tire equipment in the first place will cost considerably more than would be the case with smaller wheels, and even though it be true that the wear on the tires will be correspondingly less, still at the same time this is not generally perceived by the purchaser of the car, who is not prone to consider the subsequent cost of upkeep when he first examines what he is getting for the amount of money he is laying out in purchasing his automobile.

There are numerous other details which enter into the problem of selecting an ideal car which, in my opinion, have been overlooked by those whose descriptions have been published in the pages of THE AUTOMOBILE, and among them there is the matter of body construction and appointments. It is all very well for the carping critic to say that the average automobile buyer will more often ask a question concerning the quality of the paint on the body than he will attempt to delve into the mysteries of the lubricating or ignition systems, but it must be admitted that there is a large amount of solid sense involved in the queries which are hurled at the head of the obliging automobile salesman. Fine feathers make fine birds in the automobile world as well as in the marts of the Parisian fashions, and the man who hands his last dollar over to the automobile concern whose wares have best satisfied his critical eye is justified to a large extent in clamoring for a beautiful appearance as well as a smooth-running motor.

Body finishing has advanced along with other departments of the game, and in my specifications of the ideal car I would include a few requirements regarding this part of the car and I think that my ideas do not clash with those of the majority of automobilists who go to make up that class known to the automobile trade as the average motorist.

J. P. HEWITT.

New York City.

# Accessory Handling in Repair Shops

WHEN an automobile comes to the repair shop to be overhauled, thoroughly and well, from front to rear axle, the score of small accessories present on the car will have to be removed therefrom. This must be done to avoid such damage as will inevitably result from omitting this work. There is not a repairman or automobilist who would for a moment question the necessity of removing the accessories from the car. Clock, speedometer, odometer, lamps of all descriptions, and last but not least, tools, are too valuable to run the risk of breaking or losing them. If this should happen, it would of course mean double loss to the shop owner or manager; he would have to make reparation for the goods lost and a customer would be gone never to return.

In order to attain the end in the simplest way imaginable, the system used to insure owner and shop operator against the complication arising from disorder in this field will have to be as simple as it is efficacious. While the task of checking all small articles going off and on the car requires the attention of a conscientious and reliable worker, there is no need that he should be unusually bright or skilled. A boy will be able to attend to this end of the business, and there is nothing to bar him from a successful execution of his work. It is the practice in the large repair departments of New York City to have one boy do all the work of this kind, and superintendents are well satisfied with the success of the system.

When the car comes into the repair shop it is accompanied by a card bearing the name of the owner, the number of the car and a repair order number. The first two items are transferred to the head of the accessories card Fig. 1. Upon this card are en-

<b>IN</b>		<b>OUT</b>	
Owner	<i>L. J. Bigelow</i>	When Received	<i>Oct. 4-1911</i>
Type		When Delivered	<i>Oct. 13-1911</i>
Model	<i>31</i>		
Car No.	<i>1703</i>		

ACCESSORIES ON CAR WHEN RECEIVED			
	is	Out	
Tires { Front 2	✓	✓	
Rear 2	✓	✓	
Extra Shoes { Front			
Rear	1	✓	
Extra Tubes { Front			
Rear	1	✓	
Hub Caps, 4	4	✓	
Fenders	✓	✓	
Foot Rest			
Mat			
Cushions { Front			
Rear			
Horn, Tube & Bulb	✓	✓	
Dash Lamps	2	✓	
Head "	2	✓	
Tail "	1	✓	
Coil	✓	✓	
Tires Irons			
Robe Rail			
Crank Hanger & Strap	✓	✓	
Generator			
Special Horn <i>(Dicto)</i>	1	✓	
Gas Tank	1	✓	
Air Tank			
Special Instrument			
Clock	1	✓	
Seat Covers			
Top Curtains			
Storm Front Curtain			
Envelope			
Shock Absorber		4	✓
License Tags		2	✓
Trunk Rack			
Wind Shield		✓	✓
Storm Apron			
Oil Cans		3	2 ✓ X
Bonnet Strap			
Tire Chains		2	✓
Bumpers			
Extra Seats			
Flower Vase			
Toilet Cases		✓	✓
Toilet Articles		①	✓
Robes		2	✓
Coats		2	✓
Watch			
Gloves		2	✓
Batteries <i>ONE</i> No. Cells		4	✓
Tool Box Locked	1	✓	✓
TOOLS Kit of Tools Complete		✓	✓
<i>Speedometer</i>		1	✓
Shortage if Any			
<i>Toilet Can</i>			

*Locker #12.*

Checked in by *J.R. Harris*      Checked out by *L.P. Davis*

Fig. 1—All the small articles on an automobile are taken off and locked up while the car is being overhauled, and an exact record is kept of them

Car No. *1703*

---

Repair Order No. *2137*

---

Mr. *L. J. Bigelow*

Fig. 2—To each article, be it a tire or a pair of goggles, is attached a tag giving all the necessary information relating to it

tered all the accessories which have to be taken off the car, and the same is done with those parts which, for some reason or other, have to be removed, as was the case with the hub caps on Mr. Bigelow's car. The entries are made under the heading "In," and where it is not necessary to write numbers, a simple check will be made by the workman or boy. In most cases the articles printed on the sheet will cover the accessories which are thus handled, but when it comes to a speedometer, which does not originally appear on the form, the boy enters it on the sheet himself. There may be little objection to entering a speedometer under "Special Instrument," but a careful operator will always try to avoid any unclear statement on this card.

To each accessory, as it is taken off the car and entered on the card, a tag is attached, upon which the car owner's name, the car number and the number of the repair order are entered. Then all the accessories coming from one car are placed in a locker and its number is noted on the card, Fig. 1.

All the time the overhauling work is going on, the accessories remain in their own locker, undisturbed by the happenings in the repair shop. Only when the automobile is otherwise ready to leave the shop for its final test on the road the sundries are taken out of the locker and checked while this is being done. If, for some natural or supernatural reason, one or more of them has disappeared, the fact is noted on the card, as was the case with one of Mr. Bigelow's three oil-cans. (The card here shown has not been filled out in connection with an actual job, but only to illustrate its uses.) The operator who checks the accessories as they are taken out of the locker and replaced upon the automobile, signs his name on the card, which is

then transferred to the files of the repair department, where it is kept for any future reference that might become necessary. Whatever accessories are missing and cannot be found, are, of course, replaced.

The card illustrated is used in the repair department of the Peerless Motor Car Company, 1758 Broadway, New York City. Other concerns use somewhat different cards for the purpose of keeping track of accessories, but the variations are not fundamental. For instance, at the repair shops of the United Motor Company, Broadway and Sixty-first street, New York City, a very effective system has been introduced to help the concern to cope with the problems of the repair situation, but no special blanks are used for checking over accessories. The superintendent of the service department of this company is of the opinion that, with a reliable boy attending to the matter of checking accessories in and out, no special form is required. At the same time it is important that this work, consisting of a vast number of minor performances, should not be treated as a side issue by the worker, or chaos and consequent loss of efficiency and money will be the result. If the right sort of boy is used for the work, he will not be difficult to break in on it, and after a short time will be able to perform all his jobs with a minimum of control by the superintendent. After having introduced a system in handling the work in this department no repairman who means business has been known to discard the system. It is inexpensive to use, but too expensive to do without.

### How the Maryland Club Watches Streets

BALTIMORE, MD., NOV. 20.—At a recent meeting of the board of governors of the Automobile Club of Maryland the president appointed ten members to serve as a special committee on street repairs. This committee developed a plan for systematic notification of bad conditions in the streets of Baltimore which was heartily indorsed by the city engineer, Mr. H. K. McCay. A number of postal cards like that shown in the illustration, the reverse of which contain directions for indicating the location of holes, etc., in the paving, were sent to the club members to be filled out and mailed to the secretary. He turns them over to the city engineer as they come in, unless the trouble is within 2 feet of

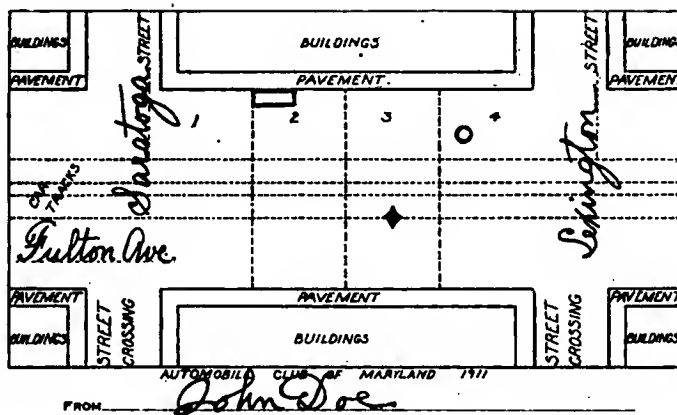

Fac-simile of postal card issued to members by Automobile Club of Maryland.

Circle O indicates round, dangerous hole. Star \* indicates sunken place in street, not necessarily dangerous. Ohlong rectangle indicates trench or depression at right angles to the street. Paragraph ¶ indicates other conditions.

the car tracks, when he notifies the railway company. Sometimes, as in the example shown, the secretary finds conditions indicated for which both the city and the railway company are responsible. In this case he turns the card over to the city engineer and sends a notice to the railroad officials.

### Another L. I. A. C. Contest

The contest for the Schimpf trophy proved so successful and the attendance was so encouraging that the contest committee of the Long Island Automobile Club has decided to hold a similar event on Saturday, November 25. It will be held under somewhat stricter rules than governed the competition for the Schimpf trophy and will be run over the 100-mile course.

The prize, which will be an automobile tire of any make and size desired by the winner, has been generously donated by Secretary Charles Hermann. The contest committee of the club consists of Edward Ashforth, William H. Kouwenhoven, Edward Melvin, William T. Wintringham and Frank G. Webb, chairman.

## Calendar of Coming Events

#### Shows

- Dec. 30-Jan. 6.....Buffalo, N. Y., Annual Show, Seventy-fourth Regiment Armory, Buffalo Automobile Trade Association.
- Jan. 2-11.....New York City, Hotel Astor, Importers' Salon.
- Jan. 6-13.....New York City, Madison Square Garden, Twelfth Annual Show, Pleasure Car Division, Automobile Board of Trade.
- Jan. 6-20.....New York City, Madison Square Garden, Annual Show, Motor and Accessory Manufacturers.
- Jan. 10-17.....New York City, Grand Central Palace, Twelfth Annual Show, National Association of Automobile Manufacturers; also Motor and Accessory Manufacturers.
- Jan. 13-27.....Philadelphia, Annual Show, First and Third Regiment Armories, Philadelphia Automobile Trade Association.
- Jan. 15-20.....New York City, Madison Square Garden, Twelfth Annual Show, Commercial Division, Automobile Board of Trade.
- Jan. 13-19.....Milwaukee, Wis., Auditorium, Fourth Annual Show, Milwaukee Automobile Dealers' Association.
- Jan. 22-27.....Detroit, Mich., Wayne Gardens, Eleventh Annual Show, Detroit Automobile Dealers' Association.
- Jan. 22-27.....Providence, R. I., Providence State Armory, Rhode Island Licensed Automobile Dealers' Association, Automobile and Accessories Show.
- Jan. 27-Feb. 10....Chicago Coliseum, Eleventh Annual Automobile Show under the auspices of the National Association of Automobile Manufacturers. Pleasure cars, first week. Commercial vehicles, second week.
- Jan. 27-Feb. 10....Pittsburgh, Pa., Sixth Annual Show, Automobile Dealers' Association of Pittsburgh, Inc. Pleasure cars, first week. Commercial vehicles, second week.
- Jan. 29-Feb. 3.....Scranton, Pa., 13th Regiment Armory, Second Annual Show.
- Feb. 3-10.....Montreal, Canada, National Show, Drill Hall, Automobile Club of Canada.
- Feb. 5-17.....St. Louis, Mo., Coliseum, Annual Show, Pleasure cars, first week. Commercial vehicles, second week.
- Feb. 12-17.....Kansas City, Mo., Annual Show, Combined Association of Motor Car Dealers.
- Feb. 17-24.....Pittsburgh, Pa., Second Annual Show, Exposition Bldg., Pittsburgh Auto Show Association, Inc.
- Feb. 14-17.....Grand Rapids, Mich., Third Annual Show.

- Feb. 17-24.....Newark, N. J., Fifth Annual Automobile Show, New Jersey Automobile Exhibition Company, First Regiment Armory.
- Feb. 17-24.....Minneapolis, Minn., National Guard Armory and Coliseum, Annual Automobile Show, Minneapolis Automobile Show Association.
- Feb. 19-24.....Omaha, Neb., Seventh Annual Show, Auditorium, Omaha Automobile Show Association.
- Feb. 19-24.....Hartford, Conn., Annual Show, Automobile Club of Hartford, State Armory.
- Feb. 20-24.....Binghamton, N. Y., State Armory, Third Annual Show, Automobile Dealers' Association.
- Feb. 20-28.....Baltimore, Md., Annual Show, Baltimore Automobile Dealers' Association.
- Feb. 21-28.....Toronto, Ont., Annual Show, Toronto Automobile Trade Association.
- Week Feb. 22.....Cincinnati, O., Annual Show, Cincinnati Automobile Dealers' Association.
- Feb. 24-March 2...Brooklyn, N. Y., Twenty-third Regiment Armory, Annual Show, Brooklyn Motor Vehicle Dealers' Association.
- Feb. 26-Mar. 2....Elmira, N. Y., Second Annual Show, Elmira Automobile Club.
- March 2-9.....Boston, Mass., Tenth Annual Show, Boston Automobile Dealers' Association, Inc.
- March 4-9.....Denver, Col., Auditorium, Annual Show.
- April 6-13.....Ottawa, Ont., Howick Hall, Annual Show, Ottawa Valley Motor Car Association.

#### Meetings, Etc.

- Dec. 20.....New York City, Waldorf-Astoria, Annual Banquet of the Automobile Club of America.
- Jan. 18-20.....New York City, Annual Meeting of the Society of Automobile Engineers.
- Race Meets, Hill-Climbs, Etc.
- Nov. 27.....Savannah, Ga., Vanderbilt Cup Race, Savannah Automobile Club.
- Nov. 30.....Los Angeles, Cal., Track Races, Motordrome.
- Nov. 30.....Savannah, Ga., Grand Prize Race, Savannah Automobile Club.
- Dec. 25-26.....Los Angeles, Cal., Track Races, Motordrome.



# THE AUTOMOBILE

Vol. XXV

Thursday, November 23, 1911

No. 21

## THE CLASS JOURNAL COMPANY

H. M. SWETLAND, President

CONDE NAST, Vice-President and General Manager

E. M. COREY, Secretary and Treasurer

231-241 West 39th Street, New York City

Cable Address - - - - - Autoland, New York  
 Long Distance Telephone - - - - - 2046 Bryant, New York

### SUBSCRIPTION RATES

United States and Mexico - - - - - One Year, \$3.00  
 Other Countries in Postal Union, Including Canada - - - - - One Year, 5.00  
 To Subscribers—Do not send money by ordinary mail. Remit by Draft,  
 Post-Office or Express Money Order, or Register your letter.

Entered at New York, N. Y., as second-class matter.  
 The Automobile is a consolidation of The Automobile (monthly) and the Motor  
 Review (weekly), May, 1902, Dealer and Repairman (monthly), October, 1903,  
 and the Automobile Magazine (monthly), July, 1907.

## Metallurgy Made Easy

IN this issue THE AUTOMOBILE begins a series of articles on the subject Automobile Metallurgy Made Easy, which series will appear weekly covering a period of several months. The object of the series is explained in the title, namely, not only making easy the question of metallurgy but also imparting elementary knowledge of the different metals entering into the make-up of the modern automobile. A great deal of ignorance exists among the laity on the subject of metals. Many salesmen glibly use the terms nickel steel, vanadium steel, chrome nickel, tungsten, bessemer, open-hearth, etc., but how many know their meaning? How many know why they are used? How many can explain why the tensile strength factor is so important in the metal entering into one part of a car and yet not important in some other parts? In the textile world a man knows that cotton clothing does not constitute a good protection against cold. He knows that cotton is suitable for Summer wear, but that wool is best for cold weather. In the food field it is a well-understood fact that fats and oils are excellent for cold weather, but bad for use in Summer or for those who take little outdoor exercise. So it is in many of the other departments of life in which people are interested, but when it comes to the problem of the metals entering into an automobile and their why and wherefore, a new question suddenly arises. It is with the hope of imparting some practical information of this character that this series has been started. The series is for the car owner, the car dealer, the salesman and the laity in general. The series is not intended for the engineer, or the metallurgist. It is too elementary for them. The series is intended to serve as an alphabet of metals, a short series of brief stories on the qualities that metals must possess in order to be useful in the different parts of the automobile.

The series opens with five articles on the qualities specified for all steels, namely, tensile strength, elastic limit, elongation, torsion and the many vibrational strains. Following this the different kinds of steels will

be treated, low-carbon steels, high-carbon steels, nickel steels and other grades such as chrome nickel, vanadium, titanium, bessemer, open hearth, crucible, electric, forged steel, rolled steel, pressed steel and steel castings, the last four referring to operations of manufacturing steels into parts intended for automobile uses. The series will continue along this line, including cast iron, cast brass, cast bronze, cast aluminum, steel castings and malleable iron castings. The bearing metals, such as phosphor bronze, white brass or bronze, babbitt and die-cast bushings, will receive attention. The entire scope of the series is such as to give the car owner who does not understand metallurgy a good general conception of the many metals; to give him a conception at least of why a certain metal is necessary in a certain part of a car so that he will be able to intelligently discuss metals and their uses when purchasing a machine.

To those whom these articles do not satisfy additional information will be furnished. All that is necessary is to write your wishes and mail them to the Editor. Sign your name and address legibly. They will both be used in conjunction with your communication. This series is for the layman and he is invited to open discussions, ask questions, etc. The series should be of special value to the dealer, the repairman and the salesman. Many of these have never been inside a factory, a foundry or a heat-treating room, so that the articles appearing will serve as an elementary course of information along a line which is daily growing in importance.

\* \* \*

## The Accessible Car

ATTENTION was drawn to accessibility in these pages some weeks ago, the chief reason advanced for it being that it reduces the cost of car operation and so administers to the general good of the cause. Since then the foreign makers have exhibited their 1912 wares to the public at the great Olympia show, and it is interesting to see how much advancement they are making along this matter of accessibility. One foreign engineer, in speaking on the subject of accessibility, mentioned the two broad phases of accessibility that should be kept in mind, namely: First, accessibility in the matter of those parts of the car that require more or less attention from the driver when on the road or in the garage at the end of a day's run; and second, that constructive accessibility which exhibits itself when a car is delivered to the repairman to have such parts as differential, clutch or gearbox overhauled or repaired.

The first class of accessibility has to do chiefly with the owner and driver. It incorporates such features as brake adjustments, which can be used without twisting the arm L-fashion around springs, shock absorbers, fenders and axle parts; it applies to the location of grease-cups, which can be reached without covering the coat sleeve with grease; it applies to the carrying of tools, which are so placed as to be obtained without getting anybody out of the car; it applies to that axle design which allows placing a jack under the front or rear axle and elevating either without having to spend a long time; it applies to the carbureter location in which the shutter-valve, for starting, the air valve or needle valve adjustments are reached without having to put on an elbow-glove; it applies to those lubricating features in which it

is possible to drain the old oil out of the crankcase without getting under the car to open a petcock in the base of the crankcase; it applies to those oil-filling designs which permit of pouring in oil from an ordinary gallon can without spilling a goodly portion over the motor parts; it applies to those magneto fastenings which allow of removing the magneto in less than 5 minutes and of replacing it in an equally short time—there are some makes in which it takes over an hour to remove the magneto. In a word, it applies to all such parts of a car as require attention either for the purpose of lubrication or adjustment.

The second accessibility is that which saves money when the car is placed in the repair shop. If the differential unit has to be removed, it should be removable through the opening in the differential housing. In some cars the entire axle has to be detached from the car, the

axle sleeves removed from the housing and other disassembly carried out. This is very expensive; it means hours of work by the repairman. If the clutch has to be removed it should be removable without having to take off the gear box or loosen the motor from its supports. Time saved means money saved in this field. So it is if the lower bearings of the connecting-rods have to be taken up; if the carbon has to be taken out of the cylinder-heads; if the piston-rings have to be replaced; if a cylinder casting has to be removed; or if a radiator has to be taken off. A buyer should look to this matter of accessibility in buying a car. With the approach of the show circuit he should study the big problem of accessibility; it will mean money saved to him after buying the car, providing the automobile which he purchases is of as good material and workmanship as the less accessible one.

## Coffin Addresses British Engineers

LONDON, Nov. 15—Howard E. Coffin, past president of the Society of Automobile Engineers delivered one of the feature addresses presented to the joint session of the Institution of Automobile Engineers and the S. A. E. held here. The joint convention was attended by about sixty members of the American society and was marked by most cordial relations between the British hosts and their visitors.

Mr. Coffin's remarks were in part as follows:

A comparison of the engineering practice entering into the better class of American cars does not show any greater degree of uniformity than is to be found in the similar class of English cars. Various spring suspensions are to be found; single and double-jointed cardan shafts are in evidence; some rear constructions are fitted with a torque-absorbing member and some are not; the drive of the road wheels is transmitted to the main frame through the springs, through radius rods or through a tubular housing for the propeller or cardan shaft, etc., as may suit the whim, the pet theory or the necessities of the individual designer.

High-powered motors are a necessity, first, because of the excess of brute power required to negotiate the poorer class of roads at speed; and, second, because of the antipathy of the average American towards the use of the gear-shift lever.

As nearly as can be judged at the moment, the coming of the long stroke will mean no lessening of bores—merely an increase in powers. A six-cylinder car, for instance, formerly 5x5½ inches in bore and stroke, will for this year be 5x7. Four-inch engines are moving up from 4x4½ to 4x5, 4x5½ and even 4x6, with no very great changes otherwise in the chassis or weight of the finished car. The low price of fuel and the low rate of or total absence of horsepower taxation tend to encourage rather than discourage this advance in power. A broad statement may almost be made, that no American car above the smallest two-seater will carry a four-cylinder motor of less than 4-inch bore. One or two instances, such as the Hupmobile, may be said to be the exceptions which prove the rule.

Another peculiarity often remarked by those from this side of the water is the brake location. Double brakes upon the rear wheels have become an almost universal practice. Almost every argument in the category can be cited in favor of the cardan shaft service brake. European precedent is a unit for it.

The character of American roads and the conditions under which American cars are forced to perform have had necessarily a great influence upon the direction of detail development. Road clearances, spring lengths and spring clearances, the avoidance of extreme lengths in wheelbase, precautionary measures against squeaks and rattles through leather and rubber liners, bronze bushings, numerous grease cups, etc., the deep ribbing or beading of all sheet-metal surfaces for the prevention of vibration, the secure locking of every bolt and nut in its place, these and a hundred and one other of the things are being given a particular attention because of the nature of the service to be encountered at the hands of the American user.

American cars, and hence American standards of motor engineering, were for years regarded as somewhat of a joke upon this side of the water. But because American design differs from those principles which have been found to succeed in Europe, it must not be assumed that the American designer is ignorant as to the trend of practice upon this side of the water. The light, high-speed, small-bore motor of 12 to 15 horsepower would perform admirably upon the English-like roads of New England, but would fail miserably in the face of the hub-deep, sticky gumbo of some sections of the Middle West.

Ample road clearance is an absolute necessity upon any car which is built in quantity to meet a nation-wide market in the states. Hence larger wheels, greater axle and flywheel ground clearance, and a generally somewhat higher car appearance than is usual upon this side.

Few cars of any power or price will go into the next season without self-starting motors. Several are already fitting starters as regular equipment for this season, and many others are following suit.

Next the lighting problem. Six months ago it looked like a walkaway for the electric generating outfit. But the fears of electric competition have brought gas lamp improvements, whereby one may, with a single switch

turning movement from the seat, turn on and light the acetylene gas lamps. The use of the acetylene self-starter also would seem to argue well for the retention of the gas light in combination.

As to en bloc castings and the protection of working parts, I do not believe that the newer American cars will be found to differ greatly from European practice.

I already have mentioned one or two chassis peculiarities. To these I might add the frequent positioning of the gear box upon the rear axle member. I presume that the arguments pro and con upon this subject are much the same with you as with us—weight and tire wear upon one side and gear quietness with manufacturing and repair advantages upon the other.

No engineering discussion would just now be complete without some mention of special motor valves. The Knight motor you know. It is now being adopted by four makers in the states, and apparently with success. There are several American valve mechanisms which seem to promise well. Every one is of the rotary disk or rotary valve type. It seems to be the American creed that if the poppet valve is dropped, it would be a mistake to replace it with another reciprocating mechanism—sleeve or otherwise.

It is not to be expected that the coming annual show in January in New York will bring out any marked change in clutch construction. The cone probably will show a percentage of increase, not because the disk and other types are being abandoned, but because a larger number of the newer and cheaper models will carry the cone as the cheapest form of the reasonably satisfactory clutch. There is one form of clutch coming into use in the states which is, I believe, entirely unknown upon this side of the water. I refer to the multiple-disk form using cork for the friction surface. I will make the broad statement that the properly constructed cork-surfaced clutch will distance all others in smoothness of action, length of service and freedom from trouble both in the factory and upon the road.

Power tire pumps are being fitted to many of the higher and medium-priced cars—the demountable rim may be said to be becoming almost the regular equipment of all but the very cheapest machines.

There is a marked tendency toward the use of roller bearings of which several makes are well known in the states.

Demountable wheels—wood—have been for several years fitted as regular equipment by one of our American makers. It does not seem probable that this practice will spread. Wire wheels have lost favor and in 1903 and 1904, when the good public made up its mind in favor of wooden spokes, American manufacturers were forced to scrap thousands of sets of wire equipment because the turn of the tide came so suddenly.

There can be no better school of design than the racing camp during the 2 weeks' practice period just before some big 200 or 300-mile road race. But here, as in every other line, a definite system must be followed if the best returns in an engineering as well as a publicity way are to be had.

A not unusual method of procedure is to place the chief engineer either directly in charge of the contest work or at least in close working contact with contest crew management. A crew is more than frequently made up of a business manager and from two to three cars with drivers and mechanics. If the engineer is wise he will have placed upon his desk an almost daily detailed report of the performance and troubles of these contest cars. I don't know of a more searching trial of steering connections, wheels, motors and, in short, of the entire driving mechanism than is the 300-mile road race or the 2,000-mile endurance run covering every possible road condition.

The encouragement of the stock car contest has been of unusual value to the engineer and hence to the progress of the industry in the states. Not only has the American engineer been constantly able to judge of the performance of standard cars under severe service conditions, but he has been no less the gainer in that he has had his whole attention riveted upon a head and hutter model, rather than upon some monster racing car.

Just now we are hearing much over here of the American invasion of the English market. There seems to be a good deal of worry, at least upon the part of the press. I don't quite see why England fears an invasion. The invasion is of the cheap car, I believe it is called. If the cheap car has a field in England, the probabilities are that it is a field to which you have not yourselves catered. It seems to me that you may meet the issue either by building low-priced cars yourselves for this demand or by keeping out of this field and sticking to the class of product to which your preferences and your methods incline you. We have been through the same thing in America exactly. The production of the \$500 car by Ford was croaked to be the death knell of all high price getting. There have been several death knells since Ford, and Ford himself is still at it to the tune of 75,000 cars for 1912.

# General Motors Reports Good Year

**N**ET profits amounting to \$4,066,251.31 were made by the General Motors Company during the 10 months preceding July 31, 1911, according to the first annual statement of that organization since the flotation of its \$15,000,000 bond issue a year ago. The period covered by the report is not a full year because the fiscal year of the company now ends July 31 in place of October 1, as heretofore. After deducting \$750,000 interest on the bond issue; \$506,226 for the April dividend and making a proportional reservation for the October dividend, there remained \$2,474,176.98 as undivided profits.

The bonded indebtedness has been reduced to \$13,454,000 by the retirement of \$1,546,000 of the bonds.

During the year it was decided to write off and reduce some of the inventories taken October 1, 1910, and this has been done to the extent of \$2,000,000, thus leaving the surplus of the company at \$1,240,175.26.

Under the financial plans of the company \$1,500,000 will be retired in 1912 and \$2,000,000 in 1913 and 1914 respectively. The remainder of the bonds will mature the following year.

The total net working capital of the corporation, according to the report is \$23,065,353.20, or practically \$10,000,000 over its bonds. During the period covered capital expenditures for permanent improvements, largely the purchase of land, building and equipment to extend the Cadillac plant, amounted to \$1,803,030.68.

President Neal says that all the factories included in the properties of General Motors were working practically at full capacity at the time the report was submitted to the directors, there having been a gradual resumption of activity.

Among the plans projected for the company is the perfection of a general staff of mechanical engineers, gasoline engine engineers, designers, production experts and other experts to advise with and assist the staffs of the various factories. The new laboratory under charge of the director of production has been elaborately equipped for testing materials and preventing factory errors. The General Motors Export Company, to sell the corporation's products abroad proposes to make Bedford Motors Limited of London its distributing branch for continental Eu-

rope. The General Motors Truck Company has been organized to market the truck products of the company.

President Neal declares he is hopeful for the coming year and states that business is on a satisfactory basis.

The assets of General Motors amount to \$54,388,072.58 according to the report of Comptroller Magee.

The liabilities include stock issues of \$30,215,830; bonds \$14,002,000; current liabilities, \$2,785,615.01 and cash surplus, \$4,443,251.31. In the above, the item of bonds was reduced to \$13,454,000 as of October 1, 1911.

During the past year the company has taken up \$46,000 of its bonded debt in excess of requirements. The action of the directors in writing off \$2,000,000 from the inventories submitted at the time the bonds were sold tends to improve the position of the company by making allowance for depreciation and possible overvaluation of assets. Of the twenty-one companies embraced in General Motors, the corporation owns a total of \$14,611,003 of their stock issues out of a total of \$16,114,003.

The report was favorably received by the trade, over which the financial situation of the company hung like a cloud prior to the successful flotation of the big bond issue in the Fall of 1910.

The retirement of \$1,546,000 of the bonds during the first year of operation under the new financial plan will decrease interest payments by \$92,760. If the regular course is followed in 1912, the interest charge will be further reduced by \$90,000 and during 1913 and 1914 respectively, \$120,000 will be cut off. Thus the charge for interest would be reduced from \$750,000 a year as it was after the bonds were sold to \$327,240.

The company has the right to retire any or all of the bonds before they are due at 102 1-2 and accrued interest.

The officers of the corporation at the date of the report were as follows: Thomas Neal, president; W. C. Durant, W. J. Mead, Emory W. Clark, vice-presidents; Standish Backus, secretary; James T. Shaw, treasurer and C. A. Magee, comptroller. The finance committee includes: Emory W. Clark, W. C. Durant, Andrew H. Green, Jr., and Edwin D. Metcalf.

## Trucks in Mail Delivery Service

WASHINGTON, D. C., Nov. 20—Three Franklin motor buses with specially built bodies were placed in the delivery service of the city post office this week. The service is being handled by David S. Hendrick, agent for Franklin cars, who was awarded the contract for furnishing the service for a four-year period at the lump price of \$74,000. The buses will make eight trips a day, four during the day shift from 7 a. m. to 4 p. m. and four from that hour to midnight. Each trip will be for collection service, but on the first three trips each day the carriers will be taken to points where their routes begin.

The idea of using motor service in this particular manner originated with Postmaster-General Frank Hitchcock, and if the service is a success here it is likely it will be extended elsewhere.

One-thousand-pound Franklin chassis are used to which have been fitted bodies built by McReynolds & Son. Seats are built in the interior of the buses, entrance being through the rear. There is also a rack for mail bags. The driver and one carrier are carried on the front seat, while there is ample room for eight carriers inside each bus.

## Akron Tire Industry Increasing

AKRON, OHIO, Nov. 20—"Things are picking up and business is becoming more and more stable during the Winter season," says C. B. Raymond, secretary of the B. F. Goodrich Company. "We expect that the coming national election will have some effect on the rubber business as on all other lines of business, and consequently no immense supplies of raw material are being stored locally, and the finished product will be kept down pretty well to actual orders. But the demand itself is increasing and I look forward to a very good year in 1912 in spite of the election."

Akron rubber factories, all of which are centered largely upon the manufacture of tires, employ 17,000 workers. Plans now indicate that this number will be increased at least 2,000 during the Winter.

Development along various market lines is credited with the steady increase of the tire demand. For one thing, local manufacturers say, automobiles are being used more generally in the rural districts. Another reason is the more general use of automobiles in Winter as well as Summer. The third reason for Akron tire activities is the development of the motor truck.

# Over Fifty Cars in Georgia State Tour

ATLANTA, GA., Nov. 20—A striking example of the trend of popular favor toward non-technical, nearly non-competitive automobile runs will be given by the tour around Georgia, which will start from Atlanta November 22 with certainly well over 50 automobiles in line.

That such a number of entries can be secured in a State where automobiles are not as numerous as they are in the Eastern States at a time when vacations are all over for a jaunt which will include six days of touring and five days at Savannah shows something of the popularity of near-sociability runs.

In this event there will be no technical requirements, 18 miles an hour will be the fastest speed required, contestants may run during the noon hour without having it counted in their running time, and any repairs can be made at any time. If repairs are made while the cars are in controls it will not be charged against the cars. Under conditions of this sort the Tour Around Georgia has been able to secure a highly creditable list of entries.

The night stops of the tour will be Americus, Valdosta, Baxley, Savannah, Dublin and Atlanta. The officials chosen already are Joe Brown Connally, referee; R. C. Clarke, starter, and P. H. Hammond, checker. Prizes amounting to \$2,600 have been offered to be divided among the winners in the various classes.

The tourists will spend from the night of November 25 until the morning of December 1 in Savannah, where they will witness the running of the Vanderbilt, Grand Prize and lesser events.

More road preparations are being made for this tour perhaps than were ever made before for a State event. Signboards have been placed at all cross roads and will serve to mark a permanent ideal tour around Georgia. In Bullock and Emanuel counties three bridges have just been completed over streams that have given trouble in previous tours. In these counties and in Laurens new strips of road are just being finished especially for this tour and hundreds of convicts are toiling long hours on the final touches.

The Adrian-Scott cut-off in Johnson county is also being completed and will be in fine condition. Unless there is rain the tourists will have excellent going all the way from Atlanta back to Atlanta. Of course, under the conditions of the tour not all the competing cars will start from the Georgia capital but can pick up the tour at any control. All that is required is that they complete the entire circuit. However, most of the contestants will come to the Gate City for the big getaway.

The entries up to November 18 were:

- 1—Atlanta Ad-Men's Club, Atlanta, Overland.
- 2—Ohio Motor Car Company, Cincinnati, Ohio, Ohio.
- 3—Dr. J. C. Luke, Ocilla, Ga., Ohio Motor Company's sales agent, Ohio.
- 4—Ohio Motor Car Company, Ocilla, Ga., sales agency, Ohio.
- 5—Jake W. Paulk, Ocilla, Ga., Ohio.
- 6—W. E. Sawyer, Americus, Overland.
- 7—S. C. Dunlap, Gainesville, E.M.F.
- 8—A. M. Kitchen, Cornelia, Ga., E.M.F.
- 9—Balkcom & Ricketson, Boston, Ga., E.M.F.
- 10—W. V. Kriegshuber, Atlanta, Chalmers.
- 11—Atlanta Chamber of Commerce, Cole.
- 12—H. B. Odell, Atlanta, Thomas, pacemaker.
- 13—W. D. Alexander, Atlanta, Dorris.
- 14—Miss Regina Rambo, Marietta, Ga., Overland.
- 15—T. C. Lauren, Atlanta, Packard.
- 16—Dr. B. L. Bridges, Ellaville, Ga., Buick.
- 17—George H. Fausa, Atlanta, Dorris.
- 18—M. Luke, Jr., Ocilla, Ga., Everitt.
- 19—Velie Motor Vehicle Company, Atlanta, Velie.
- 20—Velie Motor Vehicle Company, Atlanta, Velie, press car.
- 21—Frank G. Corker, Dublin, Ga., White Gas.
- 22—Sam Bashinski, Dublin, Ga., Chalmers.
- 23—Dolph Walker, Atlanta, National.
- 24—Marathon Motor Car Company, Nashville, Marathon, press car.
- 25—D. Woodward, Atlanta, Knox.
- 26—J. Leon Bell, Swainsboro, Ga., Cadillac.
- 27—N. E. McLeod, Swainsboro, Ga., Westcott.
- 28—U. S. Fuller, Culloden, Ga., Cadillac.
- 29—D. D. Armstrong, V. P. of T. C. A., Atlanta, Thomas.
- 30—Holmes Bros., Culloden, Ga., Buick.
- 31—W. A. Thacher, Decatur, Ga., Buick.
- 32—W. A. Thacher, Decatur, Ga., Buick.
- 33—E.M.F. Company, Atlanta, G. W. Hanson, manager, Flanders.

- 34—E.M.F. Company, Atlanta, G. W. Hanson, manager, Flanders.
- 35—E.M.F. Company, Atlanta, G. W. Hanson, manager, Flanders.
- 36—G. W. Varn, Valdosta, Ga., Cadillac.
- 37—Evelyn Harris, Southern Bell Telephone Company, Thomas.
- 38—W. G. Sutberlin, Atlanta, Overland.
- 39—Marvin R. McClatchey, Atlanta, White Gas.
- 40—F. G. Edwards, Albany, Ga., Chalmers.
- 41—Robinson Neckwear Company, Atlanta, Marmion.
- 42—Councilman Steve R. Johnson, Atlanta, Buick.
- 43—W. B. Cummings, Chief Atlanta Fire Department, Buick.
- 44—St. Elmo Massengale, advertising agency, Atlanta, Garford.
- 45—Boyd Perry, Atlanta, Ohio.
- 46—Gulf Refining Company, Atlanta, Mitchell.
- 47—Henry Meinert, Marietta, Maxwell.
- 48—Georgia Motor Car Company, Atlanta, Liberty Brush.
- 49—Georgia Motor Car Company, Atlanta, Everitt.
- 50—Swann & Campbell, Covington, Ga., Buick.
- 51—Herbert C. White, DeWitt, Ga., Maxwell.
- 52—William J. Davis, Atlanta, Pope-Hartford.
- 53—Muckalee Cigar Company, Americus, Cliff Clay, Marmon.

## Contest Board Denies Wishart's Plea

Denying the appeal of Spencer Wishart, who drove a Mercedes car into second place at the late Fairmount Park road race, suffering disqualification by the referee for failure to carry his mechanic in the latter part of the run, the Contest Board of A. A. A. upheld the ruling of the race official and placed a Lozier car driven by Mulford second in the big race and first in its class.

The board disqualified and suspended Edson Card, Jr., for an indefinite period for conducting an unsanctioned meeting on election day, but absolves the registered drivers from blame as they were led to believe the affair had official sanction.

Frank P. Fox, registered driver, was suspended for a year for participating in an unsanctioned hill climb. H. D. Fisher, suspended for incompetence at Brighton Beach, July 3, moved for reconsideration of his case, which was denied.

George H. Clark, registered driver, who was suspended for two years for competing in an unsanctioned race meeting at Los Angeles under the name of E. Z. Martin, failed to have the ban raised by the board.

## Good Roads Advocates in Session

RICHMOND, VA., Nov. 23—The first annual road congress held under the auspices of the American Association for Highway Improvement opened Monday for a meeting to cover four days. President Taft was unable to be present as expected, the reason being a severe cold. The attendance was large and representative and several of the debates were spirited. President Logan Waller Page presided at the sessions, which were held in the auditorium of the Jefferson hotel.

Monday was national day; Tuesday, states day and to-day is road users' day. To-morrow will be the most important session of the convention embracing many interesting phases of the preceding days.

## Hoosiers Plan Southern Tour

ATLANTA, GA., Nov. 20—John Orman, secretary of the Indianapolis Auto Dealers' Association, has been prospecting about the South for several weeks of late primarily for the Premier Motor Vehicle Company, but incidentally with a view of finding out how this section would do as the scene of the next I. A. D. A. run, which is planned for next Summer.

"The South is just getting ready for the higher-priced cars and it is in this section especially that the Indiana dealers will have to look to dispose of their cars," he said. "I shall advocate a run through Louisville and Nashville to Atlanta, then over to Birmingham and back home again."

# Spaces Allotted for N.A.A.M. Shows

FINAL allotments of show space for the exhibition of the National Association of Automobile Manufacturers in the Grand Central Palace have been made. There are still a few spaces that have not been definitely filled, but there are also several applications on file from which a selection will be made within a few days.

The following named companies have been added to the list or have had their original space allotments changed in one way or another: Regal Motor Car Company, main floor, space G; Columbus Buggy Company, main floor, space J-2; Gramm Motor Truck Company, main floor, space M-1; Kelly Motor Truck Company, main floor, space M-2. On the second floor are the following: Chase Motor Truck Company, space A-3; Universal Motor Truck Company, A-4; Westcott Motor Car Company, A-5; L. J. Bergdoll Motor Company, A-6; King Motor Car Company, A-7; Metz Company, A-8; L. E. Schlotterback Manufacturing Company, B-1; Newark Auto Manufacturing Company, B-2; Velie Motor Vehicle Company, C-1; Bowling Green Motor Car Company, C-2; Progress Development Company, C-3; Vandewater and Company, Ltd., D-2; Veerac Sales Company, D-3; Atterbury Motor Car Company, E-2; A. O. Smith Company, F-2; Stuyvesant Motor Car Company, H-2; Federal Motor Truck Company, H-5; Herreshoff Motor Company, H-6; G. H. Bushnell Press Company, J-4; Atlantic Motor Truck Company, J-5; Motor Wagon Company, K-3; Decatur Motor Car Company, K-4; Dayton Auto Truck Company, L-1; Lauth-Juergens Motor Car Company, L-2; Argo Electric Vehicle Company, L-3; Dart Manufacturing Company, M-1.

The list of car exhibitors, as revised to date, follows:

## AUTOMOBILES—FIRST FLOOR

- A-2 Clarke-Carter Auto Co., Jackson, Mich.
- A-3 Imperial Auto Co., Jackson, Mich.
- A-4 Ohio Electric Car Co., Toledo, Ohio.
- A-5 Velie Motor Vehicle Co., Moline, Ill.
- A-6 Velie Motor Vehicle Co., Moline, Ill.
- A-7 W. A. Paterson Co., Flint, Mich.
- B Hupp Corporation, Detroit, Mich.
- C-2 Paige-Detroit Motor Car Co., Detroit, Mich.
- D Fiat Auto Co., 1776 Broadway, New York.
- E-1 Marion Motor Sales Co., Indianapolis, Ind.
- E-2 Ideal Motor Car Co., Indianapolis, Ind.
- E-3 Krit Motor Car Co., Detroit, Mich.
- F-1 Cole Motor Car Co., Indianapolis, Ind.
- F-2 Hupp Motor Car Co., Detroit, Mich.
- F-3 Warren Motor Car Co., Detroit, Mich.
- G Regal Motor Car Co., Detroit, Mich.
- H Thomas B. Jeffery Co., Kenosha, Wis.
- J-1 Kline Motor Car Corp., York, Pa.
- J-2 Columbus Buggy Co., Columbus, Ohio.
- K Abbott Motor Co., Detroit, Mich.
- L-1 Haberer & Co., Cincinnati, Ohio.
- M-1 Gramm Motor Truck Co., Lima, Ohio.
- M-2 Kelly Motor Truck Co., Springfield, Ohio.
- M-4 Auburn Auto Co., Auburn, Ind.
- M-5 DeTamble Motors Co., Anderson, Ind.
- N-1 Middleby Auto Co., Reading, Pa.
- N-2 Lion Motor Car Co., Adrian, Mich.
- O-1 McFarlan Motor Car Co., Connersville, Ind.
- O-2 Great Western Auto Co., Peru, Ind.

## SECOND FLOOR

- A-3 Chase Motor Truck Co., Syracuse, N. Y.
- A-4 Universal Motor Truck Co., Detroit, Mich.
- A-5 Westcott Motor Car Co., Richmond, Ind.
- A-6 Louis J. Bergdoll Motor Co., Philadelphia, Pa.
- A-7 King Motor Car Co., Detroit, Mich.
- A-8 Metz Co., Waltham, Mass.
- B-1 L. E. Schlotterback Mfg. Co., East Orange, N. J.
- B-2 Newark Auto Mfg. Co., Newark, N. J.
- B-3 Sanford-Herbert Co., Syracuse, N. Y.
- C-1 Velie Motor Vehicle Co., Moline, Ill.
- C-2 Bowling Green Motor Car Co., Bowling Green, Ohio.
- C-3 Progress Development Co., 126 Liberty St., New York.
- D-2 Vandewater & Co., Ltd., Elizabeth, N. J.
- D-3 Veerac Sales Co., Paterson, N. J.
- E-2 Atterbury Motor Car Co., Buffalo, N. Y.
- F-1 Walter Motor Truck Co., 49 West 61st St., New York.
- F-2 A. O. Smith Co., Milwaukee, Wis.
- G Wyckoff, Church & Partridge, Inc., 1743 Broadway, N. Y.
- H-1 Standard Electric Car Co., Jackson, Mich.
- H-2 Stuyvesant Motor Car Co., Cleveland, Ohio.

- H-3 Walker Vehicle Co., Chicago, Ill.
- H-4 Schacht Motor Car Co., Cincinnati, Ohio.
- H-5 Federal Motor Truck Co., Detroit, Mich.
- H-6 Herreshoff Motor Co., Detroit, Mich.
- H-7 Packers Motor Truck Co., Wheeling, W. Va.
- J-1 Sullivan Motor Car Co., Rochester, N. Y.
- J-2 Cortland Motor Wagon Co., Pittsfield, Mass.
- J-3 Lippard-Stewart Motor Car Co., Buffalo, N. Y.
- J-4 G. H. Bushnell Press Co., Thompsonville, Conn.
- J-5 Atlantic Motor Truck Co., 1818 Webster Ave., New York.
- K-1 Durant-Dort Carriage Co., Flint, Mich.
- K-2 Eclipse Truck Co., Franklin, Pa.
- K-3 Motor Wagon Co., Detroit, Mich.
- K-4 Decatur Motor Car Co., Decatur, Ind.
- L-1 Dayton Auto Truck Co., Dayton, Ohio.
- L-2 Lauth-Juergens Motor Car Co., Fremont, Ohio.
- L-3 Argo Electric Vehicle Co., Saginaw, Mich.
- M-1 Dart Mfg. Co., Waterloo, Iowa.

## Where the Accessories Will Hold Forth

The list of accessory exhibitors on the third floor of the Palace includes the following:

- A-1 United Rim Co., Akron, Ohio.
- A-2 The Dean Electric Co., Elyria, Ohio.
- A-3 Booth Demountable Rim Co., Cleveland, Ohio.
- A-4 Standard Thermometer Co., Boston, Mass.
- A-5 Motz Clincher Tire & Rubber Co., Akron, Ohio.
- B-1 Lavigne Mfg. Co., Detroit, Mich.
- B-2 Power Wagon Publishing Co., Chicago, Ill.
- B-3 Grip Nut Co., Chicago, Ill.
- B-4 Motor, 381 Fourth Ave., New York.
- B-5 Modern Auto Appliances Co., Chatham, N. Y.
- B-6 Wayne Oil Tank & Pump Co., Ft. Wayne, Ind.
- B-7 Motor Vehicle Publishing Co., 24 Murray St., New York.
- B-8 The S. K. F. Ball Bearing Co., 50 Church St., New York.
- B-12 Peck Wheel Co., Chicago, Ill.
- B-13 Horseless Age, 250 Reade St., N. Y. C.
- C-1 Chas. E. Miller, 97 Reade St., N. Y. C.
- D-1 Wm. Cramp & Son Ship & Engine Bldg. Co., Philadelphia, Pa.
- D-2 General Electric Co., Schenectady, N. Y.
- D-6 Timken-Detroit Axle Co., Detroit, Mich.
- D-7 Oliver Mfg. Co., Chicago, Ill.
- E-1 Automatic Motor & Engineering Co., Chicago, Ill.
- E-2 The Class Journal Co. (Automobile), 239 W. 39th St., N. Y.
- E-4 Calmon Asbestos & Rubber Wks. of America, 103 John St., N. Y.
- E-5 Class Journal Co. (Motor Age), 239 West 39th St., N. Y.
- E-7 Chilton Co., Philadelphia, Pa.
- E-8 Automobile Journal Publishing Co., Pawtucket, R. I.
- E-12 R. I. V. Co., 1771 Broadway, N. Y.
- E-13 National Pump Co., Dayton, Ohio.
- F-1 Narragansett Chemical Co., Providence, R. I.
- G-2 Goodyear Tire & Rubber Co., Akron, Ohio.
- H-1 U. S. Tire Co., 1790 Broadway, New York.
- H-2 Ross Gear & Tool Co., Lafayette, Ind.
- H-3 Muncie Gear Works, Muncie, Ind.
- H-4 Edison Storage Battery Co., West Orange, N. J.
- H-5 Adam Cook's Sons, 708 Washington St., New York.
- J-1 Warner Instrument Co., Beloit, Wis.
- J-2 Swinchart Tire & Rubber Co., Akron, Ohio.
- J-3 Wheeler & Schebler, Indianapolis, Ind.
- J-4 Empire Tire Co., Trenton, N. J.
- J-5 The McCue Co., Hartford, Conn.
- K-1 Diamond Rubber Co., Akron, Ohio.
- K-2 S. F. Bowser & Co., Ft. Wayne, Ind.
- K-3 B. F. Goodrich Co., Akron, Ohio.
- L-1 Office M. & A. M.
- L-2 Gray & Davis, Amesbury, Mass.
- L-3 Firestone Tire & Rubber Co., Akron, Ohio.
- M-1 Veeder Mfg. Co., Hartford, Conn.
- M-2 Fisk Rubber Co., Chicopee Falls, Mass.
- M-3 Breeze Carbureter Co., 250 South St., Newark, N. J.
- M-4 Dorian Demountable Rim Co., 225 West 57th St., New York.
- M-5 Hartford Suspension Co., 150 Bay St., Jersey City, N. J.
- N-1 National Carbon Co., Cleveland, Ohio.
- N-2 Pennsylvania Rubber Co., Jeannette, Pa.
- N-3 Remy Electric Co., Anderson, Ind.
- N-4 Gemmer Mfg. Co., Detroit, Mich.
- N-5 Stromberg Motor Devices Co., Chicago, Ill.

## New Palace to Seat 4,000 More than Garden

Official announcement of a preliminary character with regard to the building of a big show structure in New York city was made Tuesday, when Manager Spratt, of the Grand Central Palace, declared that the new structure which will be built south of the present building on Lexington avenue will approximate in shape and size the present Madison Square Garden. It will differ from that building, however, in one very important particular as it will be arranged to seat about 4,000 more than the present structure.

The plans have been prepared and at present they are being presented to the New York Central Railroad for approval.



It is intended that the new building shall be ready for occupancy by next Fall.

The three floors of Grand Central Palace, which will be used for the N. A. A. M. show have a floor space of 128,000 square feet. The new building, according to report, but not officially, will have an exhibition space of about 100,000 square feet. It is intended to connect the two structures by bridged passageways, so that they will be made available for one great show in two sections.

One of these will be available for the passenger automobiles and accessories and the other for trucks and accessories. Even under those conditions, space would appear to be at a premium.

This may be accounted for by the increasing size of the trucks and the more numerous models in the passenger car lines. The Garden as it is now will barely accommodate all the lines of trucks that seek admission to the annual automobile shows held there, and while it might be possible to conduct a show equal to both weeks of the coming Board of Trade exhibition in one week, it would be found difficult to take care of all the standard cars of American motordom in any building in the world. Thus, the probabilities of the future point to the holding of two distinct shows, each continuing for one week. If this is done, New York will have buildings ample in size and facilities for holding such exhibitions.

## The Final Line-Up at the Chicago Show

OFFICIAL and final allotments for the Chicago automobile show passenger vehicle section, of the National Association of Automobile Manufacturers, contain the following changes and additions: Warren Motor Car Company, First Regiment Armory, space G-1; Flanders Manufacturing Company, H-1. Coliseum basement: Westcott Motor Car Company, 2; Crow Motor Car Company, 3; L. J. Bergdoll Motor Company, 7; Colby Motor Company, 11; Lexington Motor Car Company, 12; Standard Electric Car Company, 14; King Motor Car Company, 16; George W. Davis Carriage Company, 17.

The complete list of exhibitors for the first week follows:

### COLISEUM—AUTOMOBILES

- A-1 Winton Motor Carriage Co., Cleveland, Ohio.
- A-2 Thomas B. Jeffery Co., Kenosha, Wis.
- A-3 H. H. Franklin Mfg. Co., Syracuse, N. Y.
- A-4 Buick Motor Co., Flint, Mich.
- A-5 Nordyke & Marmon Co., Indianapolis, Ind.
- A-6 E-M-F Company, Detroit, Mich.
- B-1 Woods Motor Vehicle Co., Chicago, Ill.
- B-2 Locomobile Co. of America, Bridgeport, Conn.
- B-3 Lozier Motor Co., Detroit, Mich.
- B-4 Hudson Motor Car Co., Detroit, Mich.
- B-5 Reo Motor Car Co., Lansing, Mich.
- B-6 Olds Motor Works, Lansing, Mich.
- C-1 Packard Motor Car Co., Detroit, Mich.
- C-2 Pierce Arrow Motor Car Co., Buffalo, N. Y.
- C-3 Stevens-Duryea Co., Chicopee Falls, Mass.
- C-4 Chalmers Motor Co., Detroit, Mich.
- C-5 National Motor Vehicle Co., Indianapolis, Ind.
- C-6 Pope Mfg. Co., Hartford, Conn.
- D-1 Maxwell-Briscoe Motor Co., New York.
- D-2 Dayton Motor Car Co., Dayton, Ohio.
- D-3 Premier Motor Mfg. Co., Indianapolis, Ind.
- D-4 Cadillac Motor Car Co., Detroit, Mich.
- D-5 Willys-Overland Co., Toledo, Ohio.
- D-6 Peerless Motor Car Co., Cleveland, Ohio.
- E-1 Brush Runabout Co., Detroit, Mich.
- E-2 E. R. Thomas Motor Car Co., Buffalo, N. Y.
- E-3 Pullman Motor Car Co., York, Pa.
- E-4 Knox Automobile Co., Springfield, Mass.
- F-1 Columbia Motor Car Co., Hartford, Conn.
- F-2 White Company, Cleveland, Ohio.
- F-3 Haynes Automobile Co., Kokomo, Ind.
- F-4 Corbin Motor Vehicle Corp., New Britain, Conn.
- G-1 Metzger Motor Car Co., Detroit, Mich.
- G-2 Hupp Motor Car Co., Detroit, Mich.
- H-1 Oakland Motor Car Co., Pontiac, Mich.
- H-2 F. B. Stearns Co., Cleveland, Ohio.
- I-1 Matheson Automobile Co., Wilkes-Barre, Pa.
- K-1 Mitchell-Lewis Motor Car Co., Racine, Wis.
- L-1 Ahcott Motor Co., Detroit, Mich.

### COLISEUM ANNEX—AUTOMOBILES

- M-1 American Locomotive Co., 1886 Broadway, New York.
- N-1 Cole Motor Car Co., Indianapolis, Ind.
- O-1 Elmore Mfg. Co., Clyde, Ohio.
- O-2 Baker Motor Vehicle Co., Cleveland, Ohio.
- P-1 Ohio Electric Car Co., Toledo, Ohio.
- O-1 American Motors Co., Indianapolis, Ind.
- O-2 Selden Motor Vehicle Co., Rochester, N. Y.
- Q-3 Bartholomew Co., Peoria, Ill.

### FIRST REGIMENT ARMORY—AUTOMOBILES

- A-1 Hupp Corporation, Detroit, Mich.
- A-2 Waverly Co., Indianapolis, Ind.
- A-3 Columbus Buggy Co., Columbus, Ohio.
- A-4 Inter-State Automobile Co., Muncie, Ind.
- B-1 Marquette Motor Co., Saginaw, Mich.
- B-2 Moline Automobile Co., East Moline, Ill.
- B-3 Rauch & Lang Carriage Co., Cleveland, Ohio.
- B-4 Case Threshing Machine Co., Racine, Wis.
- C-1 Garford Co., Elyria, Ohio.
- C-2 Anderson Electric Car Co., Detroit, Mich.
- C-3 Simplex Motor Car Co., Mishawaka, Ind.
- C-4 Cartercar Co., Pontiac, Mich.

- D-1 Jackson Auto Co., Jackson, Mich.
- D-2 Aegial Motor Car Co., Detroit, Mich.
- D-3 Austin Auto Co., Grand Rapids, Mich.
- D-4 DeTamble Motors Co., Anderson, Ind.
- E-1 Kissel Motor Car Co., Hartford, Wis.
- E-2 Staver Carriage Co., Chicago, Ill.
- E-3 Krit Motor Car Co., Detroit, Mich.
- E-4 James Cunningham Son & Co., Rochester, N. Y.
- E-5 Great Western Auto Co., Peru, Ind.
- E-6 Fiat Automobile Co., 1776 Broadway, New York.
- F-1 Clarke-Carter Auto Co., Jackson, Mich.
- F-2 Imperial Auto Co., Jackson, Mich.
- G-1 Warren Motor Car Co., Detroit, Mich.
- G-2 W. H. McIntyre Co., Auburn, Ind.
- G-3 Auburn Automobile Co., Auburn, Ind.
- G-4 W. A. Paterson Co., Flint, Mich.
- G-5 McFarlan Motor Car Co., Connersville, Ind.
- G-6 Moon Motor Car Co., St. Louis, Mo.
- H-1 Flanders Mfg. Co., Pontiac, Mich.

### COLISEUM BASEMENT—AUTOMOBILES

- 1 Ideal Motor Car Co., Indianapolis, Ind.
- 2 Westcott Motor Car Co., Richmond, Ind.
- 3 Crow Motor Car Co., Elkhart, Ind.
- 4 Borland-Grannis Co., Chicago, Ill.
- 5 Broc Electric Vehicle Co., Cleveland, Ohio.
- 6 Streater Motor Car Co., Streater, Ill.
- 7 L. J. Bergdoll Motor Co., Philadelphia, Pa.
- 8 Zimmerman Mfg. Co., Auburn, Ind.
- 9 Michigan Buggy Co., Kalamazoo, Mich.
- 10 Lion Motor Car Co., Adrian, Mich.
- 11 Colby Motor Co., Mason City, Ia.
- 12 Lexington Motor Car Co., Connersville, Ind.
- 13 Ohio Motor Car Co., Cincinnati, Ohio.
- 14 Standard Electric Car Co., Jackson, Mich.
- 15 Republic Motor Car Co., Hamilton, Ohio.
- 16 King Motor Car Co., Detroit, Mich.
- 17 George W. Davis Carriage Co., Richmond, Ind.
- 18 Schacht Motor Car Co., Cincinnati, Ohio.

### COLISEUM GALLERY—ACCESSORIES

- 1 Hayes Mfg. Co., Detroit, Mich.
- 2-3 Motz Clincher Tire & Rubber Co., Akron, Ohio.
- 4 C. T. Ham Mfg. Co., Rochester, N. Y.
- 5-5a Kinsey Mfg. Co., Toledo, Ohio.
- 5b Standard Roller Bearing Co., Philadelphia, Pa.
- 6 Atwater-Kent Mfg. Works, Philadelphia, Pa.
- 7 Imperial Brass Mfg. Co., Chicago, Ill.
- 8-9 Michelin Tire Co., Milltown, N. J.
- 10 Driggs-Seahvry Ordnance Corp., Sharon, Pa.
- 11 Warner Gear Co., Muncie, Ind.
- 12-13 Pennsylvania Rubber Co., Jeannette, Pa.
- 14 Remy Electric Co., Anderson, Ind.
- 15 Swinehart Tire & Rubber Co., Akron, Ohio.
- 16 Connecticut Telephone & Elec. Co., Meriden, Conn.
- 17 Wheeler & Schebler, Indianapolis, Ind.
- 18-19 Diamond Rubber Co., Akron, Ohio.
- 20 N. Y. & N. J. Lubricant Co., 165 Broadway, New York.
- 21 Jones Speedometer Co., Seventy-sixth and Broadway, New York.
- 22 Weed Chain Tire Grip Co., 28 Moore street, New York.
- 23 Whitney Mfg. Co., Hartford, Conn.
- 24 Briscoe Mfg. Co., Detroit, Mich.
- 25 R. E. Hardy Co., Chicago, Ill.
- 26-27 Ajax-Grieb Rubber Co., Fifty-seventh and Broadway, New York.
- 28 Standard Welding Co., Cleveland, Ohio.
- 29 American Ball Bearing Co., Cleveland, Ohio.
- 30-31 Republic Rubber Co., Youngstown, Ohio.
- 32 Timken-Detroit Axle Co., Detroit, Mich.
- 33 Timken Roller Bearing Co., Canton, Ohio.
- 34-35 Consolidated Rubber Tire Co., 20 Vesey street, New York.
- 36 McCord Mfg. Co., Detroit, Mich.
- 37 A. R. Mosler & Co., 103 West Twenty-ninth street, New York.
- 38-39 Fisk Rubber Co., Chicopee Falls, Mass.
- 40 National Carbon Co., Cleveland, Ohio.
- 41 Badger Brass Mfg. Co., Kenosha, Wis.
- 42 Veeder Mfg. Co., Hartford, Conn.
- 43 Hartford Rubber Works Co., Hartford, Conn.
- 44 Continental Caoutchouc Co., 1790 Broadway, New York.
- 45 G. & J. Tire Co., 1790 Broadway, N. Y.
- 46 Morgan & Wright, 1790 Broadway, New York.
- 46 Gray & Davis, Ameshury, Mass.
- 47-48 B. F. Goodrich Co., Akron, Ohio.
- 49 C. F. Splittorf, 265 Walton avenue, New York.
- 50 National Tube Co., Pittsburgh, Pa.

- 51-52 Goodyear Tire & Rubber Co., Akron, Ohio.  
 53 Herz & Co., 187 Elm street, New York.  
 54 Diamond Chain & Mfg. Co., Indianapolis, Ind.  
 55 Wm. Cramp & Sons Ship & Engine Bldg. Co., Philadelphia, Pa.  
 56 Vesta Accumulator Co., Chicago, Ill.  
 57 J. H. Williams Co., Brooklyn, N. Y.  
 58 A. W. Harris Oil Co., Providence, R. I.  
 59-60 Hartford Suspension Co., Jersey City, N. J.  
 61 Baldwin Chain & Mfg. Co., Worcester, Mass.  
 62 Continental Motor Mfg. Co., Muskegon, Mich.  
 63 Spicer Mfg. Co., Plainfield, N. J.  
 64 Pittsfield Spark Coil Co., Dalton, Mass.  
 65 Brown-Lipe Gear Co., Syracuse, N. Y.  
 66 Weaton-Mott Co., Flint, Mich.  
 67-68 Firestone Tire & Rubber Co., Akron, Ohio.  
 69a Royal Equipment Co., Bridgeport, Conn.  
 69b Electric Storage Battery Co., Philadelphia, Pa.  
 70 Oliver Mfg. Co., Chicago, Ill.  
 71-72 S. F. Bowser & Co., Fort Wayne, Ind.  
 73 Edmunds & Jonea Mfg. Co., Detroit, Mich.  
 74 Kokomo Electric Co., Kokomo, Ind.  
 75 Byrne, Kingaton & Co., Kokomo, Ind.  
 76a U. S. Light & Heating Co., 30 Church atreet, New York City.  
 76 Stromberg Motor Devices Co., Chicago, Ill.

#### COLISEUM ANNEX, SECOND FLOOR—ACCESSORIES

- 77 Isaac G. Johnson & Co., Spuyten Duyvil, New York City.  
 78 Dean Electric Co., Elyria, Ohio.  
 79 Gabriel Horn Mfg. Co., Cleveland, Ohio.  
 80 A. O. Smith Co., Milwaukee, Wis.  
 81 Voorheea Rubber Co., Jersey City, N. J.  
 82 Auto Parts Mfg. Co., Muncie, Ind.  
 83 Eisemann Magneto Co., New York City.  
 84 W. H. Leland & Co., Worcester, Mass.  
 85 Muncie Gear Works, Muncie, Ind.  
 86 Leather Tire Goods Co., Niagara Falls, N. Y.  
 87 American Circular Loom Co., Boston, Mass.  
 88 Covert Motor Vehicle Co., Lockport, N. Y.  
 89 Link-Belt Co., Indianapolis, Ind.  
 90 Gemmer Mfg. Co., Detroit, Mich.  
 91 Havoline Oil Co., New York City.  
 92 Champion Ignition Co., Flint, Mich.  
 93 Detroit Electric Appliance Co., Detroit, Mich.  
 94 Auburn Auto Pump Co., Boston, Mass.  
 95 Heinze Electric Co., Lowell, Mass.  
 96 Booth Demountable Rim Co., Cleveland, Ohio.  
 97 Lovell-McConnell Mfg. Co., Newark, N. J.  
 98 Apple Electric Co., Dayton, O.  
 99 Bosch Magneto Co., New York City.  
 100 Sparks-Withington Co., Jackson, Mich.  
 101 Lee Tire & Rubber Co., Conshohocken, Pa.  
 102 Warner Mfg. Co., Toledo, Ohio.  
 103 Turner Brass Works, Sycamore, Ill.  
 104 National Coil Co., Lansing, Mich.  
 105 Ross Gear & Took Co., Lafayette, Ind.  
 106 Ediaon Storage Battery Co., West Orange, N. J.  
 107 Federal Rubber Co., Cudahy, Wis.  
 108 Stewart & Clark Mfg. Co., Chicago, Ill.  
 109 Empire Tire Co., Trenton, N. J.  
 110 Buda Co., Harvey, Ill.  
 111 Stutz Auto Parts Co., Indianapolis, Ind.  
 112 United Rim Co., Akron, Ohio.  
 113 Briggs & Stratton Co., Milwaukee, Wis.  
 114 George A. Haws, New York City.  
 115 General Electric Co., Schenectady, N. Y.  
 116 Jacobson & Brandlow, Pittsfield, Mass.  
 117 Dorian Remountable Rim Co., New York City.  
 118 Waukesha Motor Co., Waukesha, Wis.  
 119 International Acheson Graphite Co., Niagara Falls, N. Y.  
 120 Esterline Co., Lafayette, Ind.  
 121 Falls Machine Co., Sheboygan Falls, Wis.  
 122 Simms Magneto, New York City.  
 123 Western Motor Co., Marion, Ind.  
 124 Warner Instrument Co., Beldit, Wis.  
 125 Valentine & Co., New York City.  
 126 Batavia Rubber Co., Batavia, N. Y.  
 127 Gray-Hawley Mfg. Co., Detroit, Mich.  
 128 Avery Portable Lighting Co., Milwaukee, Wis.  
 129 J. H. Sager Co., Rochester, N. Y.  
 130 Jos. Dixon Crucible Co., Jersey City, N. J.  
 131 Glohe Machine & Stamping Co., Cleveland, Ohio.  
 132 Adam Cook's Sons, New York City.  
 133 Hoeffcker Co., Boston, Mass.  
 134 C. Cowles & Co., New Haven, Conn.  
 135 Columbia Lubricants Co., New York City.  
 136 C. A. Shaler Co., Waupun, Wis.  
 137 Pantasote Co., New York City.  
 138 Sprague Umbrella Co., Norwalk, Conn.  
 139 Continental Rubber Works, Erie, Pa.  
 140 Start-Lite Co., Chicago, Ill.  
 141 Universal Tire Protector Co., Angola, Ind.  
 142 Auto Supply Mfg. Co., Brooklyn, N. Y.  
 143 Double Fabric Tire Co., Auburn, Ind.  
 144 Hess Spring & Axle Co., Carthage, Ohio.  
 145 Dochler Die Casting, Brooklyn, N. Y.  
 146 G. Piel Co., Long Island City, N. Y.  
 147 Universal Wind Shield Co., Chicago, Ill.  
 148 Wolverine Lubricating Co., New York City.  
 149 Allen Auto Specialty Co., New York City.  
 150 Willard Storage Battery Co., Cleveland, Ohio.  
 151 Kellogg Mfg. Co., Rochester, N. Y.  
 152 Western Tool & Forge Co., Brackenridge, Pa.  
 153 Dover Stamping & Mfg. Co., Cambridge, Mass.  
 154 Stein Double Cushion Tire Co., Akron, Ohio.

#### FIRST REGIMENT ARMORY GALLERY—ACCESSORIES

- 1 The Horseless Age, 250 West Fifty-fourth street, New York.  
 2 Atlas Chain Co., Brooklyn, N. Y.  
 3 C. O. Tingley & Co., Rahway, N. J.  
 4 Barco Brass & Joint Co., Chicago, Ill.  
 5 Detroit Lubricator Co., Detroit, Mich.  
 6 Perfection Spring Co., Cleveland, Ohio.  
 7 U. S. Ball Bearing Mfg. Co., Oak Park, Ill.  
 8 The Lefever Arms Co., Syracuse, N. Y.  
 9 The Eagle Co., Newark, N. J.

- 10 The Mayo Mfg. Co., Chicago, Ill.  
 11 C. M. B. Wrench Co., Syracuse, N. Y.  
 12 Motor Vehicle Publishing Co., New York City.  
 13 Rhineland Machine Works Co., New York City.  
 14 Automatic Motor & Engineering Co., Chicago, Ill.  
 15 International Metal Polish Co., Indianapolis, Ind.  
 16 National Motor Supply Co., Cleveland, Ohio.  
 17 Wisconsin Motor Mfg. Co., Milwaukee, Wis.  
 18 S. Hoffnung & Co., New York City.  
 19 Findeisen & Kropf Mfg. Co., Chicago, Ill.  
 20 The Brown Co., Syracuse, N. Y.  
 21a Selbach Rubber Co., Boston, Mass.  
 21b Martel Blow-Out Protector Co., Chicago, Ill.  
 22 Sheldon Axle Co., Wilkes-Barre, Pa.  
 23 Peck Wheel Co., Chicago, Ill.  
 24 S. Breakstone, Chicago, Ill.  
 25 K-W Ignition Co., Cleveland, Ohio.  
 26 Perfect Window Regulator Co., New York City.  
 27 E. Edelmann & Co., Chicago, Ill.  
 28 Standard Varnish Works, Chicago, Ill.  
 29 Keystone Lubricating Co., Chicago, Ill.  
 30 Motor, New York City.  
 31 Frank Mossberg Co., Attleboro, Mass.  
 32 Norton Grinding Co., Worcester, Mass.  
 33 Morrison-Ricker Mfg. Co., Grinnell, Ia.  
 34 Chilton Co., Philadelphia, Pa.  
 35 The Class Journal Co., New York City (for Motor Age).  
 36 Longdin & Brugger Co., Fond du Lac, Wis.  
 37 The Troy Carriage Sun Shade Co., Troy, Ohio.  
 38 The Model Gas Engine Co., Peru, Ind.  
 39 Shawmut Tire Co., Boston, Mass.  
 40 Class Journal Co., New York City (for AUTOMOBILE).

#### Commercial Week at Chicago

The commercial section of the Chicago show has also undergone some changes and additions which are as follows: White Company, main floor Coliseum, space A-3; Avery Company, C-2; Morgan Motor Truck Company, M-1; Clark Delivery Car Company, M-2; Harder Fireproof Storage and Van Company, N-1. Coliseum Annex: Atterbury Motor Car Company, P-2. First Regiment Armory, main floor: Wyckoff, Church and Partridge, Inc., A-1 and A-3; Four-Wheel Drive Auto Company, B-1; Sanford-Herbert Company, B-2; Chicago Commercial Car Company, B3; A. O. Smith Company, B-6; Motor Wagon Company, C-3; Buick Motor Company, C-4; Harwood-Barley Manufacturing Company, D-3; Mercury Manufacturing Company, D-4; H. E. Wilcox Motor Car Company, D-5; Speedwell Motor Car Company, E-1; Velie Motor Vehicle Company, E-2; Poss Motor Company, E-3; Commerce Motor Car Company, F-2; Service Motor Car Company, G-2; Monitor Auto Works, G-3.

The revised list of exhibitors follows:

#### COLISEUM—MAIN FLOOR—AUTOMOBILES

- A-1 Thomas B. Jeffery Co., Kenosha, Wis.  
 A-2 Baker Motor Vehicle Co., Cleveland, Ohio  
 A-3 White Co., Cleveland, Ohio.  
 A-4 Mack Bros. Motor Car Co., Allentown, Pa.  
 B-1 Rapid Motor Vehicle Co., Pontiac, Mich.  
 B-2 Reo Motor Car Co., Lansing, Mich.  
 B-3 Kelly Motor Truck Co., Springfield, Ohio.  
 B-4 Grabowsky Power Wagon Co., Detroit, Mich.  
 B-5 Pope Mfg. Co., Hartford, Conn.  
 C-1 Packard Motor Car Co., Detroit, Mich.  
 C-2 Avery Co., Peoria, Ill.  
 C-3 F. B. Stearns Co., Cleveland, Ohio.  
 C-4 Locomobile Co. of America, Bridgeport, Conn.  
 C-5 Cartercar Co., Pontiac, Mich.  
 C-6 Waverly Co., Indianapolis, Ind.  
 D-1 Garford Co., Elyria, Ohio.  
 D-2 Peerless Motor Car Co., Cleveland, Ohio.  
 D-3 Metzger Motor Car Co., Detroit, Mich.  
 D-4 Brush Runabout Co., Detroit, Mich.  
 D-5 Knox Automobile Co., Springfield, Mass.  
 D-6 Gramm Motor Car Co., Lima, Ohio.  
 E-1 American Locomotive Co., 1886 Broadway, New York.  
 E-2 Anderson Electric Car Co., Detroit, Mich.  
 E-3 Schmidt Bros. Co., Chicago, Ill.  
 F-1 Kissel Motor Car Co., Hartford, Wis.  
 F-2 Pierce-Arrow Motor Car Co., Buffalo, N. Y.  
 G Reliance Motor Truck Co., Owosso, Mich.  
 H General Motors Co., Detroit, Mich.  
 J Staver Carriage Co., Chicago, Ill.  
 K Lozier Motor Co., Detroit, Mich.  
 L W. H. McIntyre Co., Auburn, Ind.  
 M-1 Morgan Motor Truck Co., Worcester, Mass.  
 M-2 Clark Delivery Car Co., Grand Crossing, Chicago.  
 N-1 Harder Fireproof Storage & Van Co., Chicago.  
 N-2 Federal Motor Truck Co., Detroit, Mich.  
 N-3 Adams Bros. Co., Findlay, Ohio.

#### COLISEUM ANNEX—MAIN FLOOR—AUTOMOBILES

- O Eclipse Truck Co., Franklin, Pa.  
 P-1 Alden-Sampson Mfg. Co., Detroit, Mich.  
 P-2 Atterbury Motor Car Co., Buffalo, N. Y.  
 Q-1 Durant-Dort Carriage Co., Flint, Mich.  
 Q-2 U. S. Motor Truck Co., Cincinnati, Ohio.  
 Q-3 Dayton Auto Truck Co., Dayton, Ohio.  
 Q-4 Dorris Motor Car Co., St. Louis, Mo.  
 R Mais Motor Truck Co., Indianapolis, Ind.  
 S General Vehicle Co., Long Island City, N. Y.

#### FIRST REGIMENT ARMORY—MAIN FLOOR—AUTOMOBILES

- A-1 Wyckoff, Church & Partridge, Inc., New York.  
 A-2 Walker Vehicle Co., Chicago, Ill.

- A-3 Wyckoff, Church & Partridge, Inc., New York.
- A-4 Stegeman Motor Car Co., Milwaukee, Wis.
- B-1 Four-Wheel Drive Auto Co., Clintonville, Wis.
- B-2 Sanford-Herbert Co., Syracuse, N. Y.
- B-3 Chicago Commercial Car Co., Chicago, Ill.
- B-4 Lauth-Joergens Motor Car Co., Fremont, Ohio.
- B-5 Packers Motor Truck Co., Wheeling, W. Va.
- B-6 A. O. Smith Co., Milwaukee, Wis.
- C-1 Sternberg Mfg. Co., Milwaukee, Wis.
- C-2 Henry Lee Power Co., Chicago, Ill.
- C-3 Motor Wagon Co. of Detroit, Detroit, Mich.
- C-4 Buick Motor Co., Flint, Mich.
- D-1 National Motor Truck Co., Bay City, Mich.
- D-2 Universal Motor Truck Co., Detroit, Mich.
- D-3 Harwood-Barley Mfg. Co., Marion, Ind.
- D-4 Mercury Mfg. Co., Chicago, Ill.
- D-5 H. E. Wilcox Motor Car Co., Minneapolis, Minn.
- E-1 Speedwell Motor Car Co., Dayton, Ohio.
- E-2 Velie Motor Vehicle Co., Moline, Ill.
- E-3 Poss Motor Co., Detroit, Mich.
- F-1 Schacht Motor Car Co., Cincinnati, Ohio.
- F-2 Commerce Motor Car Co., Detroit, Mich.
- G-2 Service Motor Car Co., Wahash, Ind.
- G-3 Monitor Auto Works.

The changes in the list of accessory exhibitors for commercial week are as follows:

#### COLISEUM

- 1 Model Gas Engine Works, Peru, Ind.

#### FIRST REGIMENT ARMORY—ACCESSORIES

- 3-4 Marburg Bros., Inc., 1777 Broadway, New York.
- 9 Merchant & Evans Co., Philadelphia, Pa.
- 10 The Punctureless Tire Co. of Illinois, Chicago, Ill.
- 11 The Garage Equipment Mfg. Co., Milwaukee, Wis.
- 12 Torbenson Gear & Axle Co., Bloomfield, N. J.
- 14-15 The Ariston Co., 250 West Fifty-fourth street, New York.
- 16 Milwaukee Oil Pump & Tank Co., Milwaukee, Wis.
- 20 Automobile Journal Publishing Co., Pawtucket, R. I.
- 21 American Bronze Co., Berwyn, Pa.
- 23 Power Wagon Publishing Co., Chicago, Ill.
- 24 Michigan Magneto Co., 117 Bagley avenue, Detroit, Mich.
- 25-26 Lavigne Mfg. Co., Detroit, Mich.
- 27 The John L. G. Dykes Co., 222 North State street, Chicago, Ill.
- 28 Clucker & Hixson Co., 32 Park Place, New York.
- 31 Van Cleef Bros., 7711 Woodlawn avenue, Chicago, Ill.
- 33 Chicago Steel Foundry Co., Chicago, Ill.
- 36 Hydraulic Oil Storage Co., Detroit, Mich.
- 39 Dayton Engineering Laboratories Co., Dayton, Ohio.

#### MOTORCYCLE SECTION—COLISEUM ANNEX

- 79 Minneapolis Motor Cycle Co., Minneapolis, Minn.
- 80-81 Flanders Mfg. Co., Pontiac, Mich.
- 94-95 Aurora Auto Machinery Co., Thor Bldg., Chicago, Ill.
- 96 Bicycling World Co., Tribune Bldg., New York City.
- 113 Hawthorne Mfg. Co., Inc., Bridgeport, Conn.
- 114 The Henderson Motorcycle Co., Detroit, Mich.
- 117 Nathan Novelty Mfg. Co., 84 Reade street, New York City.
- 124-125-126 Harley-Davidson Motor Co., Milwaukee, Wis.
- 127-128-129 Consolidated Mfg. Co., Toledo, Ohio.
- 130 Wagner Motorcycle Co., St. Paul, Minn.
- 131-132 Excelsior Supply Co., Chicago, Ill.
- 133-134-135 Reading Standard Co., Reading, Pa.
- 136-137-138-139 The Hendee Mfg. Co., Springfield, Mass.
- 140 Motorcycle Publishing Co., 51 Chambers street, New York City.
- 141 Motorcycling, Chicago, Ill.
- 142-143-144 New Era Auto-cycle Co., Dayton, Ohio.
- 145-146 The Pope Mfg. Co., Hartford, Conn.
- 147-148-149-150 Emblem Mfg. Co., Angela, N. Y.
- 151-152 The Pierce Cycle Co., Buffalo, N. Y.
- 153-154-155 The Miami Cycle & Mfg. Co., Middletown, Ohio.

### Cleveland Show Gets Club Sanction

CLEVELAND, OHIO, Nov. 20.—A meeting of directors of the Cleveland Automobile Show Company was held recently and a committee to manage the 1912 show was chosen consisting of the following: Frank W. Phillips, H. M. Adams, C. N. Brockway, Ray M. Colwell and Fred C. Wood.

This show committee will manage the coming season's show with the sanction and assistance of the Cleveland Automobile Club.

Fred H. Calcy, secretary of the Cleveland Automobile Club, will act as assistant secretary and the offices will be in the Hollenden Hotel.

### Big Exhibition Planned at Baltimore

BALTIMORE, MD., Nov. 20.—The Automobile Club of Maryland and the Baltimore Automobile Dealers' Association have decided upon February 20 to 28 for the next motor car show to be held in this city. The only thing holding back the rushing of the plans is the answer to the application of the two organizations forwarded to Major Washington Bowie, Jr., of the board of trustees of the Fifth Regiment Armory for use of the armory.

Both bodies have announced that the coming show will be run on larger plans than ever before and for this reason they are beginning arrangements earlier than usual.

### Garden Truck Show to Have 231 Exhibitors

Plans and preparations already made for the second annual display of motor trucks and delivery wagons to be held in Madison Square Garden, New York, during the second week of the Twelfth National Automobile Show, January 15 to 20 inclusive, indicate plainly that the commercial week will be a close second to passenger car week in magnitude and interest. Every square foot of space utilized the first week has been sold for the following week to thirty-one manufacturers of trucks and delivery wagons, and two hundred motor car accessories makers.

Business machines of all types and sizes will be displayed, ranging from package delivery cars of about 600 pounds capacity to 10-ton trucks. There will be twenty-seven makes of gasoline machines and eleven makes of electric wagons. Besides the ordinary styles of trucks and delivery wagons, there will be many machines for special purposes, such as motor fire engines, patrol wagons, ambulances, trucks with tipping bodies and trucks with power winches for hoisting purposes.

### Fall Show at Indianapolis

INDIANAPOLIS, IND., Nov. 20.—Members of the Indianapolis Automobile Trade Association are holding their first Fall show this week. Each member is exhibiting in his own place of business and the different salesrooms are beautifully decorated for the week. A special feature is a free bus service for taking visitors from one salesroom to another. There are forty-three cars in this service for the week, loaned by members of the association.

Thursday afternoon has been selected as "Ladies' Day" and during the afternoon special attention will be given to the display of electrics, coupés, limousines and other closed body cars.

### Show at Canadian Capital

OTTAWA, CAN., Nov. 20.—Ottawa's first annual automobile show will be held April 6 to 13, 1912 in Howich Hall, under the auspices of Ottawa Valley Motor Car Association. Howich Hall is the largest building in the city comprises about 40,000 square feet, half of which has already been sold. The Governor-General Foot Guard's Band has been engaged to furnish music during the show. The show committee has made plans to have the decorative feature of the show the best ever seen in Canada. Louis Blumenstein has been engaged as manager, with offices at 49 Metcalf street, Ottawa, Canada.

### Akron Is Actually Building Roads

AKRON, OHIO, Nov. 20.—The result of the past two years' good road building activity in this vicinity shows that within a short time there will be three brick roads connecting Akron and Cleveland, a distance of 35 miles, and Akron and Canton on the south, making an improved straightaway road more than 50 miles in length through beautiful touring territory. In Cuyahoga county, of which Cleveland is the county seat, there are already brick roads in all directions from the city to the county line, including two in the general direction of Akron.

Pavement from Akron north to connect with one of the Cleveland roads is already nearly done, and plans are for another big road building year in 1912. Summit county has completed 311-2 miles of country road paving this year. Twenty-five miles more are covered by the petitions filed with the county commissioners for next year.



Plowing demonstration recently given at Purdue University with three oil-pull tractors and fifty plows

**S**OUTH BEND, IND.—Three Rumely oil-pull tractors and fifty Oliver plows broke the world's record for plowing recently in a demonstration at Purdue University, Lafayette, Ind. The demonstration was arranged by Joseph D. Oliver, president of the Oliver Chilled Plow Works and also a trustee of Purdue, and President Stone of the university. Sections of the mammoth Oliver plow were hauled into place, and W. L. Paul, designer of the big fifty-bottom sectional plow, dropped the plows across the end of the field in an exact line. They turned the stubble field at the rate of 1 acre every 4 minutes and 15 seconds. The strip plowed was 58 feet 4 inches wide. The engines were operated on a low grade of kerosene distillate costing 4 cents a gallon. The three engines consumed 22 gallons an hour, reducing the fuel cost to less than 6½ cents an acre.

**BEAVER CITY, NEB.**—A new garage is being erected here by Birsell & Son.

**ST. PAUL, NEB.**—Charles Guggenman has taken the agency for the Hudson in this territory.

**OCALA, FLA.**—Work has begun on the erection of a \$10,000 garage for R. L. Anderson.

**BATTLE CREEK, NEB.**—Fuerst and Huerman will erect a new garage here in the near future.

**WYMORE, NEB.**—The Lyons Automobile Company has bought out the automobile business of E. W. Severance & Son.

**ABERDEEN, WASH.**—J. B. Knight is handling the Mitchell car in the Gray's Harbor country, with headquarters in this city.

**CORNING, N. Y.**—The Corning Automobile Company has leased the Hillman Garage at Wall street and Tioga avenue. Max Wolcott is manager of the company.

**BOSTON, MASS.**—F. L. Sanford has joined the sales force of the Henley-Kimball Company, and is in charge of the wholesale department for outside territory on Hudson cars.

**NEW YORK CITY**—The Hexter Motor Truck Company of New York, metropolitan distributor for the Gramm, is erecting a service maintenance building at 155-159 Perry street.

**BUFFALO, N. Y.**—William J. Clements, formerly manager of the Detroit branch of the Krit Motor Car Company, has been promoted to the position of manager of the company's branch in this city.

**CHICOPEE FALLS, MASS.**—A. M. Welch, formerly with the Studebaker Company, and for the past year manager of the Commercial Car Department of the Franklin works at Syracuse, N. Y., has taken up territorial work with the Stevens-Duryea Company, of this city.

**PITTSBURGH, PA.**—H. L. Mason, Jr., was recently elected president of the Automobile Club of Pittsburgh, to succeed Edward Kneeland, who resigned on account of the pressure of other business. Mr. Mason will remain in office until the annual election on February 1.

**NEW YORK CITY**—Fred W. Wright, of No. 250 West Fifty-fourth street, who recently took the local agency for the Lion car, has placed agencies with the Watson Automobile Company, of Fishkill, N. Y.; John S. Carpenter, of Goshen, N. Y., and

the McFarlan-Brooklyn Company, of Brooklyn, N. Y.

**NEW YORK CITY**—The city fire department is soon to be augmented by a monster self-propelling pumping engine which will make up to 40 miles an hour and throw 700 gallons of water a minute. The engine is about 18 feet long, with a wheel-base of 146 inches. It weighs, complete, nearly 7 tons and runs on 42-inch wheels with solid tires.

**YORK, NEB.**—The York Automobile Club is taking an active part in pushing the Canada-to-Gulf route, known here as the Meridian road. It is proposed that the road run through York, and the members of the club have all been assessed \$5 to support the project. It was voted to use the club money to purchase markers for the road through the county.

**PORTLAND, ORE.**—Several new Mitchell agencies have been placed in the Northwest during the past month. Among them are: the Ellensburg Auto Company, of Ellensburg, Wash., the Milton Garage of Milton, Ore., and the Simonton Motor Company, of Salem, Ore. The Mitchell will be represented in this city by the firm of Dulmage & Smith, who have recently erected a large garage and salesroom.

**INDIANAPOLIS, IND.**—The Ocean-to-Ocean booklet, containing 108 illustrations and telling in detail the story of the trans-continental tour of 12 Premier cars, has found a place in the public schools of this city. John G. Monihan, secretary of the 40 tourists who crossed the continent last summer, has received thousands of requests for these booklets, many of which have come from teachers and librarians.

WASHINGTON, D. C.—E. T. Howard has joined the sales force of the Marion Motor Car Company.

CHARLESTON, W. VA.—A company has been organized to manufacture automobile trucks in this city.

SHEBOYGAN, WIS.—Dr. H. A. Wagner and M. G. Dohme are building a garage at 1519 North Sixth street.

LOS ANGELES, CAL.—The Michigan car has been introduced into Southern California by C. L. Perrin, who has opened an agency.

DALLAS, TEX.—W. G. Langley, the local agent for the Franklin, recently opened a new garage at 1713 Commerce street in this city.

TORONTO, ONT.—The Gem City Garage Company is enlarging its present building by the addition of a well-equipped machine and repair shop.

UTICA, N. Y.—The Oneida Garage Company, George A. McCracken general manager, will erect a two-story concrete garage at 215 Park avenue.

WILMINGTON, DEL.—W. D. Haddock & Co. have secured the contract for the construction of a garage to be built for the Wilmington Steamboat Company.

JANESVILLE, WIS.—Edward Kemmerer has commenced work on the construction of a brick and steel garage building to contain 15,000 square feet of floor space.

MINNEAPOLIS, MINN.—L. H. Fawkes is to erect a three-story brick and reinforced concrete automobile warehouse at 1629 Hennepin avenue. It will cost \$35,000.

ST. LOUIS, MO.—A. H. Collins, sales manager of the Herreshoff Motor Company, of Detroit, has closed with George E. Maguire for St. Louis and surrounding territory.

WASHINGTON, D. C.—Additional territory has been assigned to W. P. Barnhart, local representative of the Everitt car. The new field covers the states of Virginia and North Carolina.

AKRON, O.—E. I. Whorley, formerly branch manager of the Dallas, Tex.,

branch of the B. F. Goodrich Company, has accepted a position with the Motz Tire & Rubber Company, of this city.

SEATTLE, WASH.—J. M. Stehman, formerly with J. E. Leavitt & Company, is now connected with the Mitchell Motor Car Company of this city. He will represent the company in all the Northwest territory outside of Seattle.

NEW YORK CITY.—The Eastern and Central district branch managers and salesmen of the United States Tire Company held a meeting here recently. An all-day business session was followed by a dinner at the Hotel Astor.

SALEM, O.—T. A. Vernon has sold half interest in his garage on Ellsworth avenue to E. A. Saren, of Alliance, O. Mr. Saren has taken active management of the garage though Mr. Vernon retains his district agency for the Everitt car.

MOLINE, ILL.—John E. Miller, chief engineer of the Midland Motor Company, of this city, and designer of the Moline car, was killed recently while crossing a railroad track just outside of the Midland factory yards at East Moline, Ill.

SCRANTON, PA.—John H. Felming, proprietor of the city hall garage, 330-336 Dix court, has acquired the distributing rights in Luzerne county and northeastern Pennsylvania for the American cars built by the American Motors Company, of Indianapolis, Ind.

PROVIDENCE, R. I.—According to the table of automobile trucks just compiled by the American Locomotive Company, 62 per cent. of all the trucks have been purchased on repeat orders and 78 per cent. of those in the service of department stores are re-orders.

SEATTLE, WASH.—William O. McKay, a University of Washington man, and J. D. Thomas, will open a Locomobile agency in this city. The Thomas-McKay Company, Inc., will have temporary quarters at 211 Broadway north. Mr. Thomas intends to erect a large garage in the near future.

LOS ANGELES, CAL.—Joe Ollier, manager of the southern California branch of the

Studebaker Bros. corporation, has announced the formal moving of the local branch to the new building at 1620-22-24 East Seventh street. The R. C. H. Sales Agency will occupy the quarters recently vacated by the Studebaker Company.

LOS ANGELES, CAL.—Tiring of the monotony of railroad travel, A. N. King and wife, an aged couple of Anderson, Ind., purchased a Maxwell runabout and drove from Anderson to their Winter home near here, covering more than 3,000 miles. Part of the time was spent in camping on the road and the balance as guests of ranchers.

BOSTON, MASS.—The latest acquisition of Sampson automobile trucks by the New England Telephone & Telegraph Company gives that organization a total of twenty machines—17 of 3,000 pounds capacity, 2 of 1,500 pounds and 1, the first purchased, of 4 tons. The fleet operates between a central station in this city and various stations throughout the State.

HARTFORD, WIS.—The construction work on the new addition to the KisselKar plant is rapidly progressing. The new structures, which will be under cover within thirty days, consist of a three-story concrete building, 107 by 407 feet, and a one-story building, 50 by 407 feet. Additional machinery and equipment are being rapidly installed and the factory will be equipped with an electric trolley system for economically transporting all machinery and parts from one department to another.

RACINE, WIS.—Papers have been filed in the suit of the Knox Automobile Company, of Springfield, Mass., against William A. Crane, of this city, to recover on a \$10,000 bond given by Mr. Crane in behalf of his son, George R. Crane, of Milwaukee, in 1904, upon acceptance of the Knox agency in a large territory contiguous to Milwaukee and Chicago. In October, 1906, the younger Crane went into voluntary bankruptcy, among the liabilities being \$13,666.34 due the Knox company. He was discharged from bankruptcy in February, 1907. The complaint of the Knox company states that Crane handled \$139,000 worth of cars while he represented it in Milwaukee.



The new addition to the KisselKar plant at Hartford, Wis., will be under cover in thirty days.





Group of Y. M. C. A. students inspecting Maxwell cars at the New York branch

LOUISVILLE, NEB.—The garage of William Vlok has been purchased by Haney Brothers.

SAN DIEGO, CAL.—The Bowler Motor Car Company is now the local agent for the Cole car.

SHEBOYGAN, WIS.—Arthur F. Raab, 809 North Eighth street, is a new agent for the Sampson 35.

SAN DIEGO, CAL.—The Hunt Automobile Company of this city has secured the agency for the Overland car.

DAVID CITY, NEB.—The David City Auto Company's new garage has been completed recently and is now in operation.

SAN DIEGO, CAL.—The Bay City Garage of Fifth and Ash streets, has recently taken the agency for the Everitt car in this vicinity.

PORTLAND, ORE.—L. A. Harding, president of the Nob Hill Garage & Auto Company, has taken the local agency for the American.

DES MOINES, IA.—The Brown-Corley-Ellis Company this week secured the Iowa agency for the Lozier car. The company will move into new quarters within a few weeks.

SAN DIEGO, CAL.—W. A. Chamberlain, formerly with the Firestone Tire & Rubber Company, of Akron, O., is now associated with the Tibbals-Gavin Company of this city.

DES MOINES, IA.—Secretary of State W. C. Hayward is now receiving registrations for 1912 auto licenses at the rate of 150 a day. The new numbers must be assigned by January 1.

SAN DIEGO, CAL.—W. Pitt Fessenden, formerly of Los Angeles, has recently taken charge of the William R. Ruess Automobile Company in this city, and will handle the Pope-Hartford car.

PORTLAND, ORE.—C. A. Eastman has resigned as manager of the White Motor Car Company, of Portland. His place will be taken by S. G. Houston, a member of the company's force.

MILWAUKEE, WIS.—Percy C. Avery, a well known inventor and manufacturer of motor car appliances in this city, has been elected treasurer of the Milwaukee Automobile Club to succeed Clarke S. Drake.

SAN DIEGO, CAL.—The Western Motor Car Company has leased a new home and will shortly move to Front and C streets. The Bateman-Buoy Company has secured the local agency for the Flanders and E-M-F cars.

PRAIRIE DU CHIEN, WIS.—Brunton & Foss, operating the Prairie City Garage, have dissolved partnership and the business will be continued by Mr. Foss. Mr. Brunton goes to Beloit, Wis., to engage in the garage business.

DES MOINES, IA.—A branch of the Interstate Auto and Supply Company, of Sioux City, will be opened here this week. George Jamieson will be manager. H. B. Groves, the proprietor, will take charge of the Sioux City business.

SAN DIEGO, CAL.—Charles W. Stream, general sales manager of the automobile department of the International Harvester Company, will make his home here this Winter, assisting P. M. Price in the sale of International auto wagons.

SEATTLE, WASH.—C. W. Dansic, for some time past with the Olympic Motor Car Company of this city, has been promoted to the managership of the firm. The Olympic Motor Car Company, handles the Everitt, Chalmers, Herreshoff and Pope-Hartford cars.

DES MOINES, IA.—The Colby Motor Car Company of Mason City will open a branch

in this city within a very short time. Quarters have been secured at 1017 Walnut street. W. H. Shadbourne, sales manager for the Colby company, will be in charge of the local branch.

COLUMBUS, O.—State Registrar of Automobiles, J. A. Shearer, has made his report for the quarter ending November 15, as follows: Number of owners registering cars, 2,907; number of chauffeurs securing licenses, 589; manufacturers and dealers registering, 51; duplicate tags furnished, 153. The total receipts for the quarter was \$16,976.40. Up to November 15 the department had issued 45,711 sets of number plates.

INDIANAPOLIS, IND.—After trying one line less than one month, the Rapid Motor Transit Company of this city is seriously considering the question of installing additional motor-bus lines. The present line is on North Meridian street. The new lines contemplated are in Broadway, from Massachusetts avenue to Fall Creek, and a cross town line about 7 miles long, running across the north side of the city from Brightwood to Riverside Park.

INDIANAPOLIS, IND.—Will H. Brown, president of the Mais Motor Truck Company, has been made chairman of a committee of the Indianapolis Trade Association to arrange a trade extension trip through southern States for the month of February. A special train, carrying Indianapolis and Indiana manufacturers, jobbers and wholesalers, will visit Louisville, Nashville, Atlanta, Macon, Birmingham, Jacksonville, Albany, Savannah, Montgomery, Mobile, Meridian, Jackson and Memphis.

COLUMBUS, O.—Asserting that Frank Meville, of Bellefontaine, O., doing business as the Standard Automobile Company, had filed in the probate court of Logan county, O., a petition of assignment and had previously given mortgages to prefer two creditors, the King Top Manufacturing Company, of Dayton, the E. L. Essly Machinery Company, of Chicago, and the Hamilton Bros. Company, of Bellefontaine, have filed a petition in the United States court under the bankruptcy act asking that an investigation and a fair distribution of the assets be made.

NEW YORK CITY—One hundred and twenty-five members of the West Side Y. M. C. A. automobile class visited the Maxwell and Columbia salesrooms in Sixty-first street near Broadway recently to inspect the 1912 models, the Maxwell cars that won the Glidden Tour and the latest Columbia cars equipped with the Knight sliding-sleeve motor. After inspecting these, the party entered automobiles at the door and rode to the factories of the Maxwell-Briscoe Motor Company at Tarrytown and Kingsland Point, where they saw the process of building automobiles from the entry of raw material to the shipping of the finished product.

**COLUMBUS, O.**—D. W. Short, 14 East Swan street, has taken the central Ohio agency for the 1912 Metz.

**COLUMBUS, O.**—J. B. Hoover, 621 North Fourth street, has taken the 1912 agency for the Nyborg 35. His territory covers central Ohio.

**BOSTON, MASS.**—The Haynes car is now represented in Boston by the W. L. Russell Company. This company also has the Regal agency.

**FREMONT, O.**—E. E. Pease has been placed in charge of a new concern which will open a factory for the manufacture of automobile tops. It will be located on North Arch street.

**INDIANAPOLIS, IND.**—The Merchants Auto Company, recently organized here, has located in North Delaware street. The company has taken the Indiana agency for the Woods electric.

**INDIANAPOLIS, IND.**—At a recent meeting the local board of public safety decided to ask for an appropriation of \$4,500, which will be used to buy a new emergency seven-passenger touring car for the police department.

**SANDUSKY, O.**—The capital stock of the Sandusky Auto Parts & Motor Truck Company of this city, has been increased from \$15,000 to \$500,000. A. F. Knotts is president and R. D. Mitchell secretary of the corporation.

**COLUMBUS, O.**—The United States Carriage Company, of Columbus O., which makes a specialty of automobile hearses and funeral cars, has evolved a motor hearse which is entirely different from any thing now in use.

**COLUMBUS, O.**—A shipment of 10,000 sets of number plates for 1912, for the Ohio State Automobile Department, has been made by the Scioto Sign Company, of Kenton, O., which firm supplies the tags for the coming year. The 1912 tags will be on a white background with letters in green. The usual style of the number in large figures and the name "Ohio" and the year "1912" at the end of the tag will be followed.

**DETROIT, MICH.**—The local branch of the Bosch Magneto Company, of New York, is now located in its new quarters at 1250-1252 Woodward avenue close to the corner of Henry street. The building has recently been completed, and is so arranged that the business of the company can be easily handled. Not only has the space been greatly increased over that occupied in the old building, but the staff of mechanics and ignition experts is now doubled, thus the branch is in a position to make repairs or installations on cars at a moment's notice. The offices are located at the front of the building, and back of the salesrooms is a large laboratory and repair shop. Still farther to the rear is a spacious garage.



New quarters of the Detroit branch of the Bosch Magneto Company

## Automobile Incorporations

### AUTOMOBILES AND PARTS

**ASHEBORO, N. C.**—Asheboro Motor Car Co.; capital, \$5,000; to sell motor cars. Incorporators: M. L. Davis, C. Rush, I. N. Cox.

**BLOOMFIELD, N. J.**—Torbensen Gear & Axle Co.; capital, \$120,000; to make gears and axles. Incorporators: Joseph O. Eaton, Henning O. Trube.

**GARDEN, N. J.**—Suburban Truck Co.; capital, \$10,000; to make automobiles. Incorporators: J. Ed. Fagan, Geo. H. Jacobs, Walter R. Carroll.

**CHICAGO, ILL.**—Federal Motor Car Co.; capital, \$10,000; to make and sell automobiles. Incorporators: Carey W. Rhodes, David S. Rosenthal, Leo S. Kosticbek.

**CHICAGO, ILL.**—Harder Autotruck Co.; capital, \$100,000; to build commercial vehicles. Incorporators: Henry P. Chandler, J. M. Johnson, K. Cornwall.

**CHICAGO, ILL.**—Stevens Motor Truck Co.; capital, \$10,000; to manufacture commercial automobiles. Incorporators: Geo. P. Stevens, Louis F. Stevens, Agnes M. Stevens.

**COLUMBIA, S. C.**—Consolidated Auto Co.; capital, \$5,000; to sell automobiles. Incorporators: J. B. Roddey, W. W. Pearce, J. P. Matthews, John J. Cain.

**DETROIT, MICH.**—Detroit Bi-Kar Co.; capital, \$10,000; to make automobiles. Incorporators: A. Roseroot, J. J. Berkery, J. J. Crain.

**GREENSBORO, N. C.**—Greensboro Motor Car Co.; capital, \$25,000; to make and sell automobiles. Incorporators: H. M. Chamblee, W. M. Fowler, W. J. Sherrard.

**KIEL, WIS.**—Motor Car Co.; capital, \$10,000; to sell automobiles. Incorporators: Frederick Thissen, Philip Jugenheimer, Wm. A. Duecker.

**LINCOLN, NEB.**—Hitchcock Motor Co.; capital, \$24,000; to sell automobiles. Incorporators: A. F. Hitchcock, R. E. Hitchcock, C. F. Allen, W. E. Plumer.

**LOUISVILLE, KY.**—Transit Motor Car Co.; capital, \$20,000; to manufacture freight automobiles. Incorporators: E. C. Walker, Geo. H. Laib, W. B. Young.

**MOUNT VERNON, N. Y.**—Meteor Automobile Co.; capital, \$50,000; to make engines and automobiles. Incorporators: F. A. Kately, A. F. Gescheidt, J. Emmeluth.

**NEW YORK CITY**—Delisser Automobile Selling Co. of New York; capital, \$10,000; to manufacture and deal in automobiles and supplies. Incorporators: Oliver P. Carpenter, Albert D. Bean, Geo. A. Williams.

**NEW YORK CITY**—International Horse & Motor Exchange; capital, \$75,000; to sell horses, carriages and automobiles. Incorporators: Wm. S. Blitz, C. Jason Water, L. M. Qualey.

**NOWALK, CONN.**—Reynolds Motor Car Co.; capital, \$4,000; to sell automobiles. Incorporators: Frank Reynolds, William L. Oken.

**NEW HAVEN, CONN.**—Pyramid Automobile Co.; capital, \$5,000; to deal in motor cars. Incorporators: Walter H. Goodrich, Henry P. Johnson.

**PITTSBURGH, PA.**—Krupp Motors Co.; capital, \$250,000; to make automobiles. Incorporators: D. Morgan, G. H. Anderson, James McMorrin.

**PLAQUEMINE, LA.**—Plaquemine Motor Car Co.; capital, \$10,000; to sell motor cars. Incorporators: W. A. Holloway, Henry Nadler, E. B. Schwing.

**GRAND RAPIDS, MICH.**—Michigan Auto Joint Co.; capital, \$10,000; to make universal joints and

automobile accessories. Incorporators: C. E. Perkins, F. Carter.

**SHREVEPORT, LA.**—F. W. Palis Automobile Co.; capital, \$10,000; to sell motor cars. Incorporators: F. W. Palis, W. T. Moore, R. E. Allison.

**SOUTHAMPTON, N. Y.**—Walter Motor Truck Co.; capital, \$100,000; to manufacture and repair automobiles. Incorporators: W. Walter, E. L. Walter, C. W. Fletcher.

**WOACESTER, MASS.**—Acme Motor Car Co.; capital, \$40,000; to manufacture automobiles. Incorporators: William Vincent, Ernest D. Wheeler, Albert D. Watson.

### AUTOMOBILE GARAGES AND ACCESSORIES

**CHICAGO, ILL.**—Advance Motor Specialties Co.; capital, \$10,000; to manufacture motor accessories and supplies. Incorporators: Geo. Heldman, Norman A. Street, L. E. Street.

**CHICAGO, ILL.**—Empire Auto Top & Supply Co.; capital, \$20,000; to make automobile tops. Incorporators: Henry Graft, Jr., Albert N. Charles, Joel E. Bullard.

**CHICAGO, ILL.**—National Tire Spring Co.; capital, \$125,000; to manufacture accessories. Incorporators: S. L. Sigman, L. Valence, C. H. Jackson.

**CINCINNATI, OHIO**—Spring Hub Automobile Wheel Co.; capital, \$10,000; to manufacture automobile wheels. Incorporators: Edgar N. Woolley.

**COLUMBUS, OHIO**—Dunlap Manufacturing Co.; capital, \$50,000; to make tools and automobile parts. Incorporators: S. H. Dunlap, T. S. Dunlap, L. F. Sater, E. C. Watson, A. I. Schetenstein.

**GASTONIA, VA.**—Gastonia Garage Co.; capital, \$50,000; to conduct a garage business and automobile agency. Incorporators: A. G. Myers, John C. Rankin.

**MISHAWAKA, INO.**—Star Garage Association; capital, \$5,000. Incorporators: Guy Stutzman, Louis Slick, Marion Pancake, Charles Fenner, Clara Stock-Barger.

**NEWARK, N. J.**—Suspended Pneumatic Tire Co.; capital, \$500,000. Incorporators: Chas. H. Stewart, Albert P. Stewart.

**NEW YORK CITY**—D. S. L. Co.; capital, \$60,000; to operate automobile garages. Incorporators: J. C. Leuse, J. J. Caine, J. P. Dubois.

**NEW YORK CITY**—Trautman Air Rubber Tube Co.; capital, \$100,000; to manufacture automobile tires. Incorporators: Ira Trautman, August V. Denis, Wm. G. Newhall.

**NORFOLK, VA.**—Virginia Automobile Garage & Repair Corporation; capital, \$10,000; to conduct a garage business. Incorporators: H. L. Page, A. M. Bopp, P. A. Page.

**PHILADELPHIA, PA.**—Motor Spring Co.; capital, \$1,000,000; to manufacture and deal in self-starting devices. Incorporators: Leonard E. Wales, L. E. Replogle, Lew W. Cooper.

**RICHMOND, VA.**—Broad Street Garage; capital, \$5,000; to conduct a garage. Incorporators: A. Zebary, O. B. White, C. Stokes.

**ST. LOUIS, MO.**—Curtis Jack & Truck Co.; capital, \$75,000; to make a combination jack and hand truck for automobiles. Incorporators: J. R. Curtis, II, C. Flunker, A. W. Smith, Otto Stifel, George E. Booth.

**ST. LOUIS, MO.**—Schelph-Budke Tire & Rubber Co.; capital, \$10,000; to manufacture automobile tires. Incorporators: Geo. H. Schelph, C. Milton Schelph, Conrad Radke, Jr.

# OF INTEREST *to the* INDUSTRY



New storage battery department of the Apple Electric Company at Dayton, O.

**DAYTON, OHIO**—The Apple Electric Company, of this city, has added a new battery department to its plant. The new department is fully equipped for the work of turning out storage batteries in large quantities. The company makes a specialty of electric lighting systems for automobiles, motor boats and country homes.

**NASHVILLE, TENN.**—The Tennessee Auto Company is erecting a \$4,500 building.

**ALEXANDRIA, VA.**—The B. F. Board Motor Truck Company is planning to erect an additional building.

**BUTLER, PA.**—New machinery is being purchased to add to the equipment of the Butler Vulcanizing Company.

**RICHMOND, VA.**—Ground has been broken for an automobile factory which the Kline Motor Car Company is to erect in this city at a cost of \$300,000.

**BUFFALO, N. Y.**—The Niagara Gasoline Motor Company of this city is building a one-story brick addition to its plant at Breckenbridge and Barton streets.

**WILKES-BARRE, PA.**—G. S. Delaney has entered the employ of the Matheson Automobile Company as factory manager and has assumed his duties at the local plant.

**LANSING, MICH.**—The Hildreth Manufacturing Company has increased its capital stock from \$75,000 to \$112,500. The company makes gasoline motors and pumps.

**ELMIRA, N. Y.**—The Morrow Manufacturing Company, of this city, manufacturer of automobile parts, is adding a large amount of new machinery to the equipment of its plant.

**LOUISVILLE, KY.**—The Continental Car

and Equipment Company, of this city, has developed a 3 1-2-ton truck which it will manufacture either here or in New York. McKinley Boyle is president of the company.

**MONROE, WIS.**—Fred Herrmann, formerly assistant foreman of the testing laboratories of the Thomas B. Jeffery Company, in this city, is now associated with Richard Patterson in the management of the Monroe Automobile Company.

**PONTIAC, MICH.**—Don McCord, formerly sales manager of the Marion plant, has been appointed general manager of the Flanders Electric factory in this city. Mr. McCord has been sales manager of this firm for several weeks.

**DETROIT, MICH.**—The Timken Roller Bearing Company and the Timken-Detroit Axle Company have established an advertising department. Edwin A. Walton, formerly assistant advertising manager of the Burroughs Adding Machine Company, is manager.

**DETROIT, MICH.**—Architects Albert Kahn and Ernest Wilby have awarded the A. J. Smith Construction Company the general contract for the new testing shed of the Hudson Motor Car Company at 2901 Jefferson avenue. The shed is to be a two-story brick building, 50 by 500 feet.

**NASHVILLE, TENN.**—The Marathon Motor Works of this city has increased its capital stock to \$1,000,000 and has purchased the plant of the Carbon & Oil Company adjoining its present plant. New equipment, to cost about \$225,000, will be installed and the product of the works will be increased to 3,500 cars a year.

**DETROIT, MICH.**—Through the merging of the sales organizations of the Rapid

and the Reliance divisions of the General Motors Truck Company, L. J. Fasquelle is now general sales manager of the company. T. P. Myers is in charge of the company's service department.

**BUDAPEST, HUNGARY**—American automobile manufacturers are neglecting a fertile European field in this country. The American automobile is practically unknown here in spite of the general prosperity of the 20,000,000 inhabitants and most of the machines in use are of French make.

**NEW YORK CITY**—American automobile manufacturers appear to be finding a better market in other parts of the world than in Europe, for during the first eight months of this year, the exports of American cars to South America exceeded in value those to France, Germany or Italy, and the exports to British Oceania were not far behind those to the United Kingdom.

**NEW YORK CITY**—Henry C. McComb, chief engineer for the E. R. Thomas Motor Company before its reorganization, recently resigned as assistant general manager of the Louis J. Bergdoll Motor Company. He has joined the forces of Wyckoff, Church & Partridge, Inc., of Fifty-sixth street and Broadway, this city, as manager of the commercial engineering department.

**LOS ANGELES, CAL.**—The Moro is the name given to the new car produced by J. B. Morrow, of Morrow, Loomis & Co., a local automobile firm, and James R. Fouche. A large building has been leased and it is expected that by January 1 all necessary equipment will be in place and the manufacture of a number of cars begun.

**LOUISVILLE, KY.**—The Kentucky Wagon Manufacturing Company has succeeded to the business of the Electric Vehicle Company, by the purchase of the designs, drawings, patterns and equipment of the latter company, and will build all sizes of electric commercial vehicles. H. Hewitt, who was in charge of the Electric Vehicle Company, has been made general manager of this department.

**NEW YORK CITY**—Mr. W. Walter, who has been manufacturing commercial cars at 49-51 West Sixty-sixth street in this city, has incorporated the Walter Truck Company to take over the business. The new company will manufacture the same models on a larger scale. A factory and garage will be erected in the neighborhood of Broome street. Mr. Walter is president of the company and will give his attention to the making of trucks. Mr. Fletcher, the secretary and treasurer, will look after the selling end of the business.

# PATENTS GONE TO ISSUE

**CLUTCH.**—Friction device of the expanding band type.

3. This clutch (Fig. 1) consists of a driving and a driven member, one of the members being in form of a shaft and the other in that of a pulley. To the shaft a clutch disc is fixed, and an expansion ring is adapted to engage the inner surface of the pulley. An expansion ring is provided which may be made to engage the inner surface of the pulley, while an expansion lever pivoted to the disc engages one end of the ring. Means are provided to actuate this lever, and a movable device carried by the disc and acted on by the other end of the ring may be operated to apply positive outward pressure to the ring.

No. 1,008,945—to John C. Brewin, Philadelphia, Pa. Granted November 14, 1911; filed December 14, 1910.

**AUTOMOBILE SLEIGH.**—A vehicle for Winter travel in cold countries.

4. This patent relates to a construction (Fig. 2) of a vehicle having a front axle structure carrying vehicle-supporting members, and a vehicle body supporting bearing frames at its rear end. Outer shaft sections are journaled in the bearing frames, and to these sections wheels are fixed. A vertical arch frame is mounted on the bearing frames and has journal boxes vertically reciprocable in opposite sides of it.

In the journal boxes an intermediate shaft section is journaled, and coupling mechanisms intervene between the ends of the intermediate shaft and the adjacent ends of the outer shaft sections, whereby the latter may be connected or disconnected. On the intermediate shaft section a spur propulsion wheel is mounted, which drives the mechanism of the vehicle.

No. 1,008,409—to Alexander Finkelstein, Chicago, Ill. Granted November 14, 1911; filed March 27, 1911.

**STEERING AND DRIVING MECHANISM.**—A combination of these two functions in one device.

1. This patent refers to a combination (Fig. 3) with a cross member of brackets depending at each end of that cross member, oil casings supported by the brackets between themselves and the cross member, and shafts which are journaled in the casings mentioned. To the shafts wheels are secured, and they also carry, within the casings, bevel gears, which in turn mesh with bevel gears. On the cross member oil casings are mounted, in which a driving gear is located, which serves to drive the second-mentioned bevel gears. Means are provided to operate the driving mechanism. Lugs on the first-mentioned rotatable oil casings extend in opposite directions therefrom, and parallel steering rods connect the lugs so that the first-mentioned oil casings may be rotated to steer the wheels mentioned.

No. 1,008,376—to Samuel E. Siders, Delphos, Kan., and George A. Siders, Novinger, Mo. Granted November 14, 1911; filed October 26, 1909.

**MACHINE FOR MAKING RUBBER SHEETS.**—Apparatus designed for converting latex into crude rubber.

This machine contains a rotatable metallic drum with enclosed ends and means for uniformly applying heat to the drum periphery, from the interior thereof. A vat containing latex delivers it intermittently to the drum periphery, and means are provided to remove the vat from the drum after every application of latex, and to elevate it again to apply another coat of the material after the preceding coat has been dried by the hot drum.

No. 1,008,607—to Frank E. Mellinger and Henry H. Markley, Lumija, Mexico. Granted November 14, 1911; filed January 19, 1911.

**SPARK PLUG.**—In which a special design of support for the insulation is used.

3. The plug (Fig. 4) has an insulation mass with an enlarged portion surrounded by gaskets enclosed by a soft metal band. This band has an enlarged middle portion lying between the gaskets to stiffen the band and space the gaskets.

No. 1,008,485—to Charles A. Mezger, New York, N. Y. Granted November 14, 1911; filed November 23, 1908.

**BRAKE CONNECTIONS.**—Means for applying the brakes to a vehicle wheel.

2. The device is of the friction class and combines an axle with a friction member on it and rotates with it, and an opposed friction member which has an annular groove. A frictional surface is composed of an annular series of radial independent sections, which are interposed between the friction members and loosely confined when the brakes are released.

No. 1,008,792—to John H. Davis, Brooklyn, N. Y., assignor to Momentum Automatic Brake Company, New York, N. Y. Granted Nov. 14, 1911; filed July 24, 1909.

**FRICTION DEVICE.**—Shock absorber in which two inversely positioned series of wedges take up thrust transmitted to device.

2. The patent refers to a device composed of a wall against which a series of wedge members have their bases resting, and on which they are laterally movable, the wedges being partially intermeshed with a series of inverse wedge members which are endwise movable. The base end of the latter wedges project beyond the apices of the first-mentioned series, and a cam having a waved surface acting upon the projecting bases of the second-mentioned series of wedges moves in a path substantially parallel to the wall.

No. 1,008,635—to Phelps M. Freer, Barberton, Ohio. Granted November 24, 1911; filed February 5, 1910.

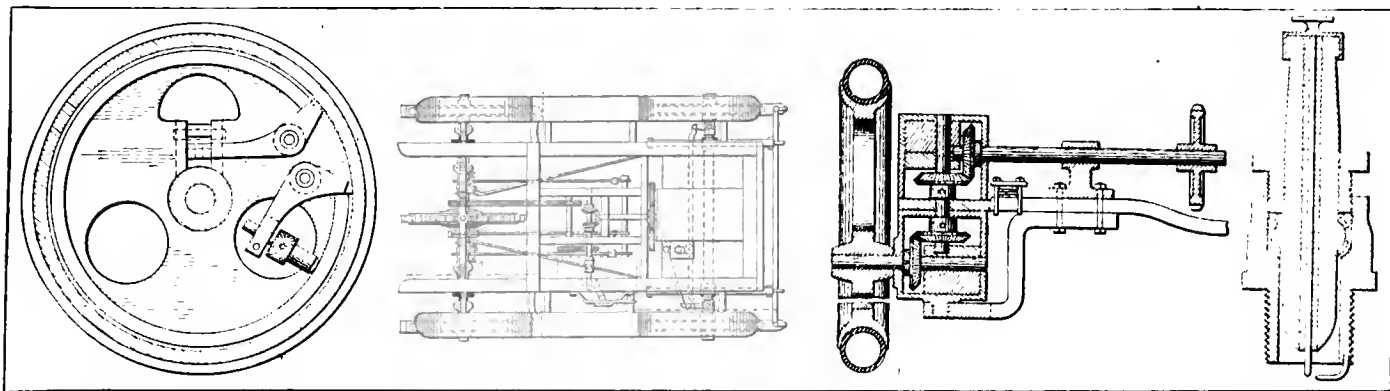

Fig. 1—Brewin friction clutch. Fig. 2—Finkelstein sleigh. Fig. 3—Siders steering and driving mechanism. Fig. 4—Mezger spark plug

# Newest Ideas Among the Accessories

## Automatic Lock Switch

**T**HE Automatic Lock Switch, which is illustrated in Fig. 1, is made the idea of preventing the starting of an automobile by an outsider who has no business to do this. It consists of a Yale lock, which is placed over the face of the coil box on the dashboard in place of the ordinary switch. Turning the key to the right or left, as the case may be, brings the switchbar into contact with the battery or magneto points, depending on whether the former or latter kind of circuit is used. It is impossible to withdraw the key, except when the current is broken or on neutral; nor can a short-circuit be caused through the use of the key, since the current must go through the coil in order to be effective. But it cannot pass through the coil unless the switchbar is brought into the right position by the key. The lock is so constructed that the switch-case cannot be removed even after the four screws holding it to the coil box are taken out, except if the key is inserted and in a releasing position. As the lock is of the Yale type and only one key is delivered with each lock there is no chance of a thief starting the car as long as the driver holds on to his key. Of course this type of lock is applicable to any type of ignition system, with only a different arrangement in the installation of the lock. The Automatic Lock Switch is manufactured by the Blackburn Specialty Company, Cleveland, Ohio.

done on automobile engines or transmissions. The stand consists of two upright pressed-steel members, as may be seen from Figs. 2 to 4. A shaft which carries a large wheel at one end is laid across the stand

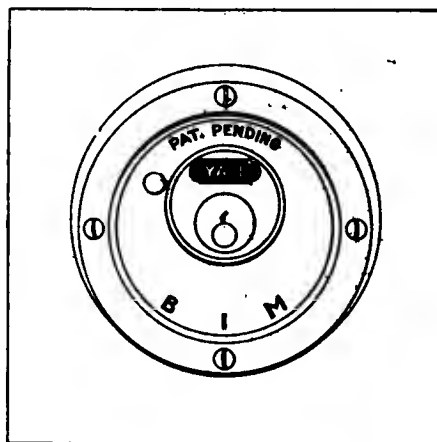

Fig. 1—Automatic lock switch

proper being rigidly fixed at the points of contact with same. A horizontal frame, or rather a working table consisting of several bars, is so connected with the cross-shaft that, if the latter is turned, the working table is moved to an upwardly inclined position, while normally it rests on the two vertical stand members. The cross-shaft may be turned by means of the worm engaging the wormwheel, the worm being forged integrally with a shaft provided with a handle. As Fig. 2 shows, the working table may be brought to any position within 180 degrees, and provision is made for holding it there by locking the wheel. In Fig. 4 the extreme opposite from the position of Fig. 3 is seen so that if the upper half of the engine is up in

Fig. 3, access may be had to the lower side of the crankchamber if the working table is tilted to the position shown in Fig. 4. Naturally, the field of this stand is not limited to the work done on engines or transmissions, but may be used as well on most other machine shop jobs.

## Slikup Rubber Compound

Slikup, which comes in tins of varying size, is a compound prepared to protect and beautify rubber, especially the running treads of the tires. It is made white and gray, and is applied to the tires by means of a brush, like paint, from which it differs, however, in its composition. When applied to the rubber surface it fills any air holes existing therein and is very effective in preventing sand blisters; at the same time it protects the rubber from the effects of sunlight. Each time the tire is washed a little of the coat is removed, and after some time a new coat must be applied.

Before applying Slikup to the tread, it is thoroughly washed with water to clean all dust, dirt and oil from it. The contents of the can before being brushed on the tread is stirred until it reaches the consistency of a thick cream. Then a flat varnish brush is dipped into it and the stuff is applied to the tire surface. It takes about 45 minutes to dry. The can should always be kept closed so as to keep foreign matter out of it and to keep the solution at the proper concentration, and nothing should be added to the Slikup under any circumstances. If stirring does not bring about the desired change in Winter time it may become necessary to place the tin into a hot-water bath; then the can should of course be closed. Slikup is manufactured by N. B. Arnold, 98 Montague street, Brooklyn, N. Y.

## Haco Machine Stand

The Haco motor and machine stand, product of the Hathorn Auto Company, of Mason City, Ia., is made with the object of insuring accessibility in repair work

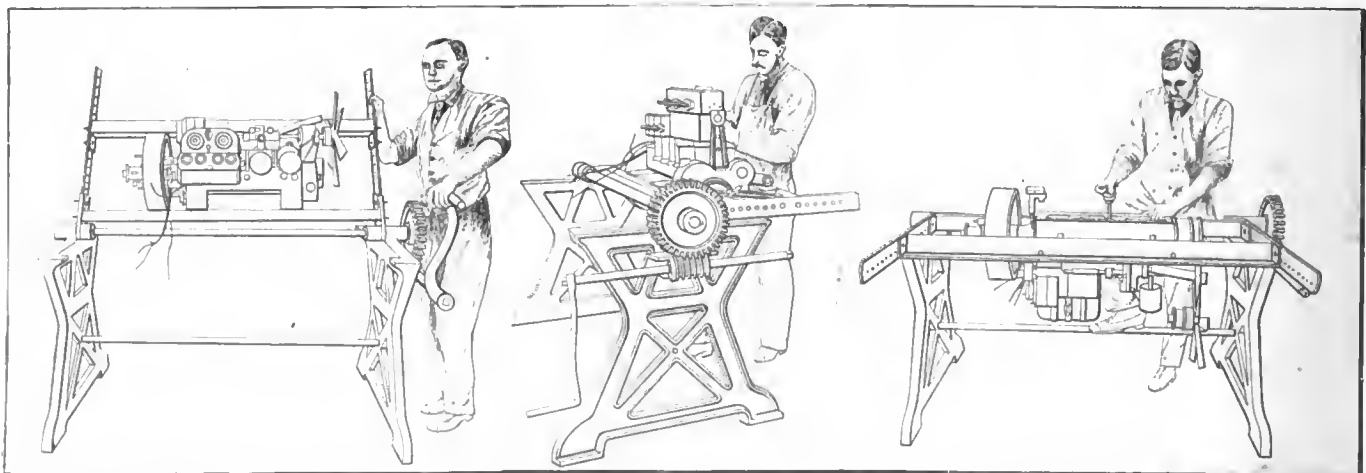

Fig. 2—Lifting the motor by the Haco stand. Fig. 3—Motor in upright position on the Haco. Fig. 4—Getting at the bottom of the crankcase



# THE AUTOMOBILE

## Lozier Smashes Vanderbilt Record

Mercer and E-M-F Win Light Car Races



1—Ralph Mulford, Who Drove the Lozier to Victory in the Vanderbilt. 2—Hughie Hughes, Who Won the Savannah Trophy in the Mercer. 3—Ralph De Palma, Second in the Vanderbilt. 4—Mulford Winning the Vanderbilt Race



SAVANNAH, GA., Nov. 27—Mulford, in a Lozier to-day won the eighth Vanderbilt cup race, over the famous Savannah course. He covered the 291.38 miles at an average pace of 74.07 miles an hour, a pace which makes all former Vanderbilt cup marks look small.

It is 9 miles an hour faster than any previous race for this American classic and is not much below the famous record recently made by the National on the Santa Monica course, namely

202 miles at a speed of 74.628 miles an hour.

When Mulford had covered twelve laps or 205 miles to-day,

his average speed was 74.9 miles an hour, or faster than the Santa Monica pace for the same distance. His performance cannot be classed as an intermediate record as he did not announce his intention before the start of the race to go after the record as required by the rules governing official records.

Ralph De Palma, in a Mercedes, was second, being but 2 minutes 11.32 seconds behind the leader, with Wishart in another Mercedes third, and Grant in the second Lozier fourth. Fifth place went to Parker in a Fiat, the only one of three Fiats to finish.

THE WINNERS	
<b>VANDERBILT CUP</b>	
Lozier—Mulford	291.38 mi.....236:00.67
—	
<b>SAVANNAH TROPHY</b>	
Mercer—Hughes	222.82 mi.....195:37.22
—	
<b>TIEDEMAN CUP</b>	
E-M-F—Witt	171.4 mi.....176:23.34

Much credit was given to Disbrow, in his Pope-Hummer, that ended in sixth place, although losing much time through the breaking of the exhaust valve and from manifold troubles. Two Abbott-Detroit cars of medium horsepower, were running at the finish. No. 9, driven by Mitchell, having finished sixteen of the seventeen laps, when the race was declared off; and No. 17 having completed fourteen laps. Of the fourteen cars that entered, six finished the race, two others were running at the finish and six dropped out.

### A Spectacular Race

THE race was most spectacular from start to finish. It came as the big act of the day's program which consisted of three races, two of which, the Savannah and Tiedeman cup races for smaller cars at shorter distances, were staged early in the day, starting at 8 o'clock. The Vanderbilt was not started until these were completed and it was exactly 11:45 when the starter got the first car away. In spite of this late start Mulford had covered the 291.38 miles at 3:45 o'clock.

The setting was perfect in every respect. The weather was clear, a cloudless sky with a fresh breeze making conditions ideal. The big grandstand, seating over 8,000, was well filled, and there were a couple of thousand more in the bleacher stand across the course. The road surface was prepared to the minute. The entire 17.14 miles of the course had been resurfaced and over \$15,000 spent in oiling it. The surface in some places was a little soft but the pace to-day was 4 miles an hour faster than that of the Grand Prize race over the same course last year. The course has several turns but they are all banked and on some of these the cars travelled at as high as 65 miles an hour. On the long stretches the capabilities of the cars constituted the only limit to the speed. The crowds were not all confined to the grandstands, scores of picnicking parties lining the home-stretch and other parts of the course that afforded a good view of the racers.

The speed made was higher than anticipated. It was freely stated that the pace would be somewhere between 73 and 74 miles an hour, but few expected it to go over 74. It is much faster than any previous Vanderbilt, the times for which as well as the distances are given herewith:

Year	Distance	Speed
1904	284.3	52.2
1905	283	61.4
1906	297.1	60.8
1907	not held	
1908	258.6	64.3
1909	278.08	62.8
1910	278.08	65.18

The speed of to-day shows what are the possibilities of medium sized cars on a level course with banked turns. It is generally rumored to-day that the Grand Prize cars of unlimited cylinder capacity will not make much better time over this course on Thanksgiving day.

Perhaps the biggest lesson in to-day's race has been the victory of what might be designated stock cars, as compared with



Hughie Hughes, Savannah winner, speeding on the backstretch

**TABLE SHOWING STANDING OF THE CONTESTANTS IN**

No.	Car	Driver	Lap Miles	1	2	3	4	5	6
				17:14	34:38	51:42	68:56	85:70	102:84
8	LOZIER.....	Ralph Mulford.....	E.T...	27:33	41:11	54:56	68:42	82:31	
			L.T...	13:48	13:45	13:38	13:45	13:46	13:49
10	MERCEDES.....	R. De Palma.....	E.T...	26:47	40:03	53:46	69:25	84:37	
			L.T...	13:33	13:14	13:16	13:43	15:39	15:12
4	MERCEDES.....	Spencer Wishart ..	E.T...	27:20	40:55	54:55	71:27	85:33	
			L.T...	13:44	13:36	13:35	14:00	16:32	14:06
1	LOZIER.....	Harry Grant.....	E.T...	31:09	48:45	62:49	76:59	91:06	
			L.T...	14:04	17:05	17:36	14:04	14:10	14:07
11	FIAT.....	E. H. Parker.....	E.T...	27:59	43:17	59:12	74:11	89:01	
			L.T...	13:57	14:02	15:18	15:55	14:59	14:50
3	POPE-HUMMER	L. Disbrow.....	E.T...	28:56	43:16	61:48	76:02	90:20	
			L.T...	14:32	14:24	14:20	18:32	14:14	14:18
9	ABBOTT-DET...	L. A. Mitchell.....	E.T...	32:46	48:57	65:06	81:17	97:22	
			L.T...	16:34	16:12	16:11	16:09	16:11	16:05
7	ABBOTT-DET...	Carl Limberg.....	E.T...	42:29	59:56	78:21	96:25	107:11	
			L.T...	20:22	22:07	17:27	18:25	18:04	20:46
12	MARMON.....	Cyrus Patchke.....	E.T...	27:16	40:54	58:07	71:42	88:06	
			L.T...	13:41	13:35	13:38	17:13	13:35	16:24
2	MARMON.....	Bob Burman.....	E.T...	28:17	42:05	55:56	69:50	83:38	
			L.T...	14:17	14:00	13:48	13:51	13:54	13:48
14	FIAT.....	D. Bruce Brown...	E.T...	28:49	42:50	56:49	71:03	85:23	
			L.T...	14:34	14:15	14:01	13:59	14:14	14:20
15	FIAT.....	Joe Matson.....	E.T...	29:07	43:11	63:23			
			L.T...	13:55	15:12	14:04	20:12		
6	MERCER.....	Hughes.....	E.T...	43:05	61:51				
			L.T...	14:32	28:33	18:46			
5	JACKSON.....	Harry Cobe.....	E.T...						
			L.T...	16:29					

specially designed racing machines. Mulford's car was not strictly stock in that the cylinders were bored out 1-8 inch, making them 5 3-8 by 6 inches bore and stroke. The Rayfield carbureter used was fitted with an adjustment of the needle valve onto the steering column and two extra air inlets mounted on the intake and two exhaust valves. The Lozier pair are chain driven machines and have a pronounced racing appearance due to shrouding the radiator by continuing the hood forward beyond it and curving it in. The three Fiat cars were all racing types having intake

### Some of the More Prominent of the



Ralph Mulford, who took Vanderbilt, at the wheel of his Lozier



Cyrus Patschke negotiating a sharp turn in his Marmon

**THE VANDERBILT RACE, 17 LAPS, 291.38 MILES**

7	8	9	10	11	12	13	14	15	16	17
119:98	137:12	154:26	171:40	188:54	206:68	222:82	239:96	257:10	274:24	291:38
95:56	109:58	123:39	137:24	151:02	164:43	179:43	193:24	208:07	222:19	236:00.67
13:25	14:02	13:47	13:45	13:38	13:41	15:00	13:41	14:43	14:12	13:41.7
98:10	115:17	129:07	142:49	156:25	170:03	186:30	197:02	210:40	224:26	238:11.95
13:33	17:07	13:50	13:42	13:36	13:38	13:27	13:32	13:38	13:46	13:45
99:35	113:31	127:17	141:03	163:48	177:37	191:16	204:53	218:32	232:22	246:20.37
14:02	13:56	13:46	13:46	22:45	13:49	13:39	13:37	13:39	13:50	13:58
105:13	119:17	133:22	147:36	161:44	175:52	190:20	206:10	220:09	234:12	250:23.57
14:07	14:04	14:05	14:14	14:08	14:08	14:28	15:50	13:59	14:03	16:11
103:49	118:55	133:55	148:51	163:44	178:31	193:06	207:45	224:08	239:35	254:25.88
14:48	15:06	15:00	14:56	14:53	14:47	14:35	14:39	16:26	15:27	14:59
104:38	118:57	133:21	147:47	162:09	178:56	198:00	212:30	227:13	244:30	259:02.68
14:18	14:19	14:24	14:26	14:22	16:47	19:04	14:30	14:43	17:17	14:32
113:24	129:28	145:46	161:54	178:02	196:21	212:29	228:38	244:46	263:00	
16:02	16:04	16:18	15:08	16:08	18:19	16:08	16:09	16:08		
138:04	155:45	173:25	190:57	208:41	226:32	248:34	266:27			
20:53	17:41	17:40	17:32	17:44	17:51	22:02	17:53			
101:29	131:50									
13:23	30:21									
97:28										
13:50										

to finish. Military passes were granted to officials and photographers, but otherwise not a person crossed the blackened oiled surface. The scoring was done on two large boards, one serving for each end of the grand stand.

**Vanderbilt Lap by Lap**

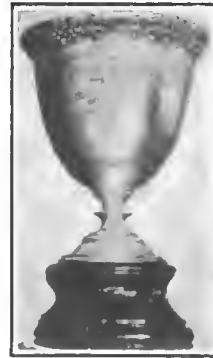

Vanderbilt Cup

**L**AP 1—It was a whirlwind start, six of the fourteen starters setting out to do the distance under the 14-minute mark and they did it. Ralph De Palma, the favorite before the start, set the pace with a lap in 13:33 or 76.5 miles an hour and Patschke in a Marmon was close by in 13:41, with Wishart in another Mercedes, Mulford, Lozier, and Matson, Fiat, close behind.

It was a magnificent opening spectacle. Everybody wondered what the time would be, and when the opening lap was so favorable, everyone looked to the establishing of some new road race marks.

Starter Wagner got them away at 30-second intervals and it was a long 7-minute wait from the time Matson left the tape until the megaphone announced car coming. Down the stretch a white meteor flashed toward the big grandstand turn and Grant in No. 1 Lozier, first away, was first to cross the tape. Behind him came Burman in his yellow Marmon, a literal streak, as it flew down the black polished roadway.

Scarcely had Burman passed the judges' stand than the sombre gray Mercedes No. 4, Wishart, took the curve in arrow-like fashion and was gone. Disbrow, in the Pope-Hummer, was not 200 yards back of him. Then came a wait, seconds seemed minutes and minutes, hours. Eyes were strained into the bushes on the stretch where the black ribbon of road emerged from the foliage. A wait and then a yellow flash, Patschke in his Marmon, came and went. Another glance saw Mulford in his white Lozier, and with white uniform, chase Disbrow.

These five were ahead of the rest of the field. Then followed a wait. Everyone was anxious. Presently, the gray Mercedes, No. 10, of De Palma shot into the curve and was gone. Behind him came No. 9, Jackson, the only time the grandstand was to get a sight of it. It withdrew in the second lap.

Everybody looked for some of the red Fiats, they all started late, their numbers being 11, 14 and 15. Parker in 11 came first. A blue Abbott was next, No. 9, driven by Mitchell, and then came 15 and 14, Matson, driving 15, having passed his team mate on the opening lap. With all past the grandstand the crowd settled down to watch the scoreboards and see how the struggle progressed.

Lap 2—This was a Mercedes lap with De Palma first, Wishart third and Patschke's Marmon sandwiched between. Mulford

and exhaust valves mounted in the cylinder heads. An overhead camshaft is used and the valves and all actuating parts are entirely enclosed by a metal cover, thus allowing all of the parts to operate in oil. They are chain driven machines and are of the same type as competed in the Grand Prize last year but with reduced bore to bring them under the 600-cubic inch classification.

Savannah lived up to its previous reputations in the manner of conducting the event and patrolling the course. The soldiers were out early and not a person was on the course from start

**Vanderbilt Contenders in Practice**

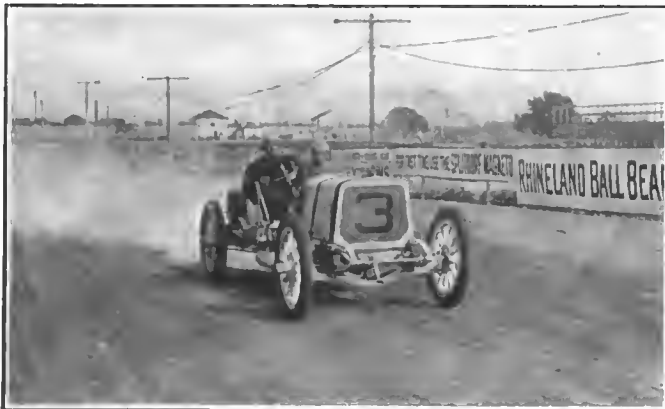

Harry Grant, the two-time Vanderbilt winner, in his Lozier



Bruce-Brown in the Fiat doing 75 miles an hour in practice

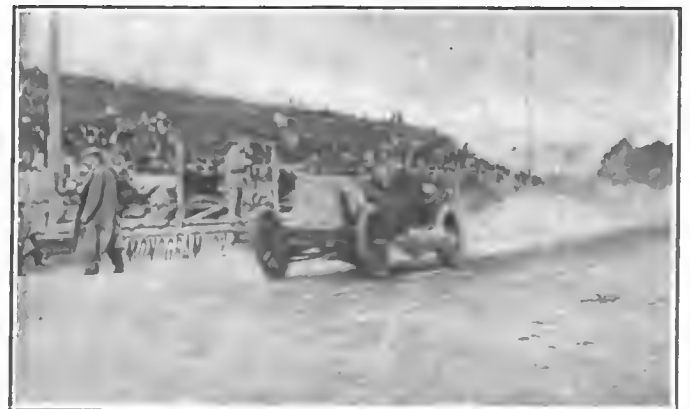

Parker in his Fiat did exceptionally fast work in practice

Grant's Lozier climbing into fourth place and pushing the Disbrow Pope into fifth place. This was the end of a duel between these two cars that had continued practically from the fourth lap. At this point Grant was gradually pulling away, his lead being 11 seconds. At this part of the race Mulford was leading the two Mercedes by 4 and 5 minutes and Grant was 5 minutes back of them. Parker's Fiat was 2 minutes behind Grant.

Lap 11—This lap saw Wishart's Mercedes drop from second to sixth place, putting De Palma in second, Grant third, Disbrow fourth and Parker fifth. Disbrow had his trouble in the back stretch and he was 22.45 on the circuit, one of the slowest any of the leaders finished. De Palma made the lap in 13:42 and Mulford in 13:45, both running very closely together. No. 9 Abbott was maintaining its pace by going the circuit in 15:08, a pace of 68 miles an hour.

Laps 12 and 13—Not a change in the position of the contestants occurred in these laps. In lap 12 Mulford stopped 1

minute 6 seconds to change a left rear shoe and took on gasoline and oil. Disbrow stopped to change a left rear, losing 1 minute 35 seconds.

Wishart was traveling fast in these laps and was rapidly cutting down the lead that Grant, in third place, had on him. De Palma was also traveling very fast and, due to Mulford having to stop, had cut his 5-minute lead to about 2 minutes. This marked part of the grand struggle on the part of both De Palma and Wishart to dislodge the leading Lozier. Before stopping at its pit the Lozier had 5 minutes on De Palma, 13 minutes on Wishart, 14 minutes on Parker's Fiat and 13 on Disbrow.

The finish laps, 14, 15, 16 and 17, can properly be considered together because in lap 14 Wishart nosed Grant out of third place and from that to the end there was not a change in the positions of the eight cars that were running. This order was Mulford, De Palma, Wishart, Grant, Parker, Disbrow and Mitchell and Limberg in Abbots. As told in another place, the fight for first place was between De Palma and Mulford in the four laps.

But with only a couple of laps to go the handicap was too much for the Mercedes. Wishart was firm in third and Grant safe in fourth, having 4 minutes' lead on Parker, who was fifth. Six cars finished the entire seventeen laps and the two Abbots were running at the finish. No. 9 finished sixteen laps and No. 7 finished fourteen. Six cars dropped out of the race.

### Story the Pits Told

THE elimination story is never a pleasant one in connection with a road race and in this respect, to-day's race exacted a heavy toll in six cars being eliminated. The causes of all of the eliminations have not been learned to date. The majority of the troubles were due to vibration. Burman, in his Marmon, had magneto trouble; Matson's Fiat broke a radiator trunnion. Brown's Fiat bent the rear axle and then lost a rear wheel; the Mercer suffered magneto troubles. No report was had on the Jackson. Patschke's Marmon had reported motor trouble without specifying any details.

Thirteen stops were made at the grandstand pits for repair,

TABLE SHOWING POSITION OF EACH CAR IN THE

No.	Car and driver.	1st	2d	3d
8	Lozier, Mulford.....	4	4	4
10	Mercedes, De Palma.....	1	1	1
4	Mercedes, Wishart.....	3	3	3
1	Lozier, Grant.....	7	10	10
11	Fiat, Parker.....	6	5	9
3	Pope-Hummer, Disbrow.....	9	8	8
9	Abbott-Detroit, Mitchell.....	13	11	11
7	Abbott-Detroit, Limberg.....	14	12	12
12	Marmon, Patchke.....	2	2	2
2	Marmon, Burman.....	8	6	5
14	Fiat, Bruce-Brown.....	11	7	6
15	Fiat, Matson.....	5	9	7
6	Mercer, Hughes.....	10	13	13
5	Jackson, Cobe.....	12		



Ralph DePalma in the Mercedes finished second in the Vanderbilt



Billy Knipper in a Mereer was a great favorite with the crowds

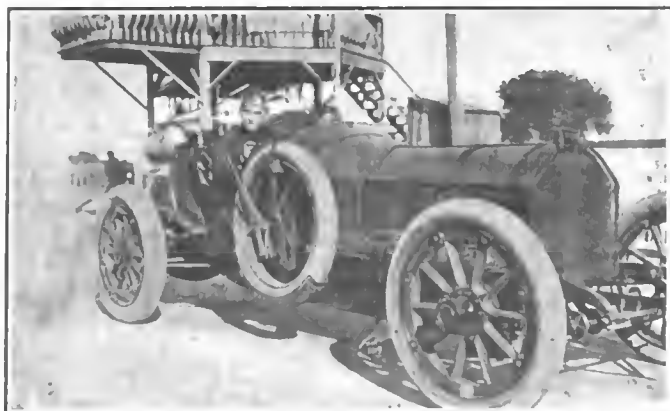

Cy Patschke in his Vanderbilt and Grand Prize Marmon

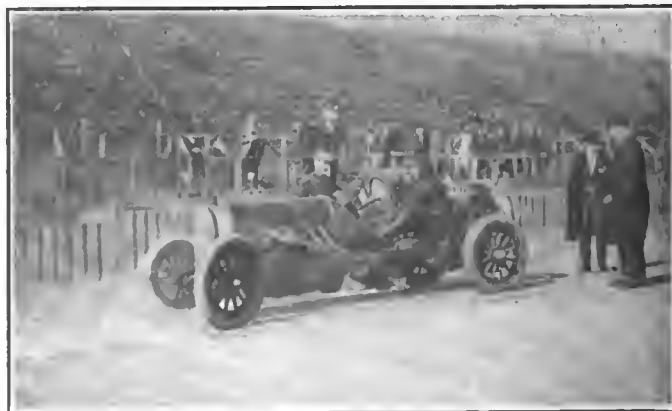

Louis Disbrow ready to try out his Pope-Hummer

replacements and supplies during the running of the Vanderbilt cup race to-day. They were as follows: No. 15, Matson's Fiat, lap 2, water, time 1 minute; No. 4, Wishart's Mercedes, gasoline and tire, time 2:10; No. 11, Parker's Fiat, lap 4, tire, time 1:26; No. 15, Matson's Fiat, water and tires; No. 10, DePalma Mercedes, lap 5, water, gasoline and oil and tires; No. 7, Abbott, lap 6, gasoline and oil and adjusting carbureter air valve; No. 12, Patschke's Marmon, water and gasoline and rear tire, time 1:21; No. 8, Mulford's Lozier, lap 12, tire and gasoline and oil, time 1:04; No. 3, Disbrow's Pope, gasoline, oil and left tire, lap 11, time 1:20; No. 9, Abbott, lap 11, gasoline, water and oil, time 1:37. No. 1, Grant's Lozier, lap 12, tire, gasoline and oil; No. 1, lap 15, tire, time 26 seconds; No. 7, Abbott, lap 11, oil and water and oil line broken and carbureter air valve broken.

These do not represent all of the stops, however, as there was a tire control on the back stretch and many cars stopped there to take on and put off tires as well as to make changes. At this extra tire control the driver and mechanic were compelled to do all of the work in a tire change.

**FASTEST LAPS MADE BY CARS IN THE VANDERBILT RACE**

No.	Fastest Car	Lap Time	Lap Time	Lap Time	Lap Time	M.P.H.
8	Lozier	7-13.25	3-13.38	11-13.38	12-13.41	77.8
10	Mercedes	2-13.14	3-13.16	13-13.27	7-13.33	78.4
4	Mercedes	3-13.35	2-13.36	14-13.37	13-13.39	77.2
1	Lozier	15-13.59	16-14.03	4-14.04	8-14.04	75.7
11	Fiat	2-14.02	13-14.35	14-14.39	12-14.47	73.4
3	Pope-Hummer	5-14.14	6-14.18	7-14.18	8-14.19	72.8
9	Abbott-Detroit	10-15.08	7-16.02	8-16.04	6-16.05	68.2
7	Abbott-Detroit	3-17.27	10-17.32	9-17.40	10-17.41	59.6
12	Marmon	7-13.23	2-13.25	5-13.35	5-13.38	77.6
2	Marmon	3-13.48	6-13.48	7-13.50	4-13.51	76.4
14	Fiat	4-13.59	3-14.01	5-14.14	2-14.15	76.0
15	Fiat	1-13.15	3-14.04	2-15.12	4-20.12	78.3
6	Mercer	1-14.32				72.0
5	Jackson	1-16.29				63.1

### Lozier-Mercedes Duel

THE duel from start to finish between Ralph Mulford and Ralph DePalma was one that will long live in the minds of those who watched the changing conditions. In a word, De Palma took the lead in the race for the first four laps and then Mulford took it for the remaining thirteen.

De Palma led Mulford by 1:10 at the end of the fourth lap which was changed to a Lozier lead of 53 seconds at the end of

**VANDERBILT RACE AT THE END OF EACH LAP**

	4th	5th	6th	7th	8th	9th	10th	11th	12th	13th	14th	15th	16th	17th
3	1	1	1	1	1	1	1	1	1	1	1	1	1	1
1	2	3	3	3	3	3	3	2	2	2	2	2	2	2
2	5	5	4	2	2	2	2	6	4	4	3	3	3	3
9	9	9	8	6	5	4	3	3	3	3	4	4	4	4
7	7	7	6	4	6	6	5	5	5	5	5	5	5	5
8	8	8	7	5	4	5	4	6	6	6	6	6	6	6
11	10	10	9	7	7	7	7	7	7	7	7	7	7	7
12	11	11	10	9	9	8	8	8	8	8	8	7	7	7
6	6	6	5	8										
4	3	2	2											
5	4	4												
10														

lap five, De Palma having to change tires on the course and stop at grandstand pits for 2 minutes while tires were put in the rack and oil and water taken on, the result being that Mulford had a lead of 2:06 at the end of lap six. He increased it to 2:14 in lap seven and at the end of lap eight, with the race practically half over, Lozier had a lead of 5:19 and lap nine saw the Lozier's lead increased to 5:29; this was the greatest margin that separated the two cars at any point in the contest. De Palma cut 4 seconds in lap ten and lap eleven saw 2 more seconds cut off. It was a gallant chase that De Palma was putting up and an equally gallant race that Mulford was giving him. Three more seconds were cut off in lap twelve so that at the end of this circuit Mulford had a lead of 5:20. It was at the end of this lap that Mulford slowed down to change a left rear tire and take on gasoline and oil, losing, all told, 1:06. He lost more because the Savannah people were anxious to have him cross the tape so that his time for the distance might be taken. At



Louis Disbrow giving the word for a time trial of his Case car

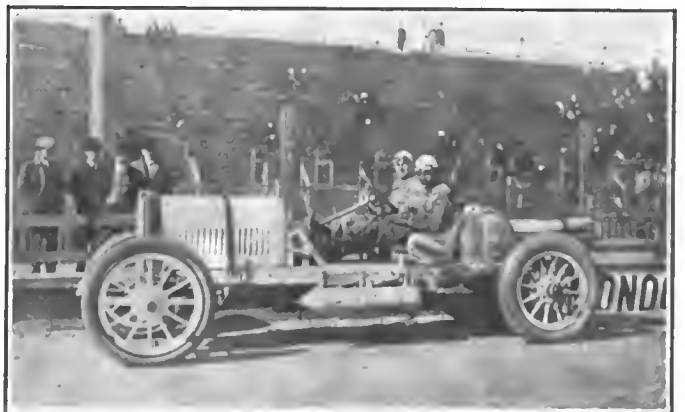

Harry Grant poses for the staff photographer before a tryout



The Grand Prize Benz team, composed of Hemery, Bergdoll and Hearne, made a great impression



this point he had covered 205 miles and the crowds wanted to know if he had beaten the speed at the recent Santa Monica race which was at a distance of 202 miles.

At the end of lap thirteen Mulford had a lead of but 3:47 on the Mercedes, which was being pushed hard, De Palma doing the lap in 13:27, which proved to be his third fastest in the race.

At the end of lap fourteen the lead of 3:47 was cut to 3:38. Excitement was intense at the end of lap fifteen when Mulford had to stop to put a tire on the rack, which cost him 10 seconds. Taking on a tire meant that he had made a change on the course and he had a lead of but 2:33 with two laps to go.

In spite of changing a tire on the course and stopping at the pit he made the lap in 14:43. Lap sixteen and seventeen were anguishing processions. Everybody wondered, if the Lozier would have to change another tire and, if so, the Mercedes would almost overtake it. At the end of lap sixteen there was 2:07 between the speed monsters, at which time both were given the green flag by the starter, meaning one more lap to go.

The Lozier had a margin of 2:11:28, it having gained 4 seconds on the Mercedes in the last circuit.

**Analyzing the Figures**

The Mercedes made fourteen of the seventeen circuits under the 14-minute mark, which means over 73.5 miles per hour. The record of 13:14 is 78 miles an hour.

The following are De Palma's laps: 13:14, 13:16, 13:27, 13:32; 13:33, 13:33, 13:36, 13:38, 13:38, 13:42, 13:43, 13:45, 13:46 and 13:50. He had three slow laps, namely; 5, 6 and 7 in 15:39, 15:12 and 17:07 seconds.

As compared with this the winning Lozier made thirteen laps under the 14-minute mark, the fastest being the seventh in 13:25. Mulford showed remarkable regularity by doing four laps in 13:41 each and three in 13:45 each and two in 13:38 each. This goes to recall the steady pace held by Mulford during last year's Vanderbilt Cup race.



The Dowelle turn has been skillfully banked and made safe



One of the worst turns on the course—at Roche and Dale avenue

**TABLE SHOWING STANDING OF THE CONTESTANTS IN THE**

No.	Car	Driver	Lap Distance	1 17:14	2 34:28	3 51:42	4 68:56
22	MERCER	H. Hughes	Elap. T.	15:18	30:19	45:23	60:16
			Lap. T.		15:01	15:04	18:53
21	MARMON	Heineman	Elap. T.	15:57	31:29	46:41	61:54
			Lap T.		15:32	15:12	15:13
25	MARMON	J. Nikrent	Elap. T.	16:21	31:58	47:33	63:10
			Lap T.		15:37	15:35	15:37
24	MERCER	W. F. Barnes, Jr.	Elap. T.	15:22	30:17	45:07	60:24
			Lap T.		14:55	14:50	15:17
23	CASE	Buckley	Elap. T.	19:53	39:42	58:38	77:23
			Lap T.		19:49	18:56	18:45
27	MERCER	B. Knipper	Elap. T.	15:19	30:28	45:41	60:49
			Lap T.		15:09	15:13	15:08
26	CASE	Disbrow	Elap. T.	14:56	29:38	44:16	59:23
			Lap T.		14:42	14:48	14:53

**Mercer Wins Savannah**



Savannah Trophy

THE race for the Savannah trophy was started this morning at 8 o'clock and was for a distance of 222.82 miles, or thirteen laps of the circuit. Seven cars started, three Mercers, two Marmons and two Case specials. Hugh Hughes, driving 22 Mercer, won, going the 222.82 miles in 195 minutes and 37 seconds, or 68.04 miles per hour. Heineman, driving a Marmon, was second, being 4 minutes behind the Mercer, and third place was won by Nikrent in another Marmon.

This race was a Mercer-Marmon duel from the fifth lap to the end. Up to the fifth lap, Disbrow driving a Case Special led with Mercer second and Marmon third. Disbrow withdrew in the fifth lap owing to motor trouble and this put the Hughes Mercer into the lead which position it maintained until the end.

The Mercer-Marmon duel was interesting from start to finish. It was not a case of one Marmon contesting against one Mercer, but the three Mercers were waging as against the two Marmons with varying success, although Hughes was never headed off.

**TABLE SHOWING STANDING OF CONTESTANTS IN THE RACE**

No.	Car.	Driver.	Lap Distance.	1 17:14	2 34:28
35	E. M. F.	Frank Witt	Elap. T.		35:46
			Lap T.	18:03	17:43
34	E. M. F.	R. Evans	Elap. T.		36:53
			Lap T.	18:41	18:12
33	E. M. F.	Jack Tower	Elap. T.		37:45
			Lap T.	19:23	18:22
36	FORD	Frank Kulick	Elap. T.		37:10
			Lap T.	20:13	18:57
31	ABBOTT-DETROIT	M. Roberts	Elap. T.		32:47
			Lap T.	16:23	16:24
32	ABBOTT-DETROIT	R. L. Hartman	Elap. T.		16:24
			Lap T.	18:04	



The ironing of the course continued between times all last week

**SAVANNAH CHALLENGE TROPHY, 13 LAPS, 222.82 MILES.**

5	6	7	8	9	10	11	12	13
85:70	102:34	119:36	137:12	154:26	171:40	188:54	205:58	222:52
75:07	89:54	104:43	119:36	135:11	150:22	165:20	180:23	195:37.22
14:51	14:47	14:49	14:53	15:35	15:11	18:58	15:03	15:14
77:06	92:21	107:35	122:49	138:07	153:29	170:41	186:19	201:41.49
15:12	15:15	15:14	15:14	15:18	15:22	17:12	15:38	15:22
78:42	94:08	109:37	125:07	140:50	156:38	172:27	188:35	204:42.93
15:32	15:26	15:29	15:30	15:43	15:48	15:49	16:08	16:07
75:45	93:56	109:56	124:07	139:31	155:02	170:35	186:13	
15:21	18:11	16:00	14:11	15:24	15:31	15:33		
96:02	130:03	148:53	167:51	188:26	207:45			
18:39	34:01	18:50	18:58	20:35	19:19			
75:58	91:01	106:07	133:44					
15:09	15:03	15:06	27:37					

## E-M-F Wins Tiedeman

This race was started at 8 o'clock this morning with the ground white with frost which made it cold during the first few laps. Disbrow started out to burn up the course and would have without doubt been an easy winner had his car held up. He made his first lap 22 seconds faster than his nearest competitor; at the end of lap two he had a 49-second lead over Barnes, in a Mercer; in the third lap his lead was 51 seconds and in the fourth it was 54 seconds ahead of Hughes. Once the Case was out, the race was taken in hand by Hughes, who led to the finish.



Tiedeman Trophy

While the Case was leading, the Mercers were running second and third with Marmon fourth, and in lap five it was Mercer one, two and three, the drivers being Hughes, Barnes and Knipper. Lap six saw Knipper move to second place and Heineman in No. 21, Marmon, annex third position. Lap seven saw more Marmon gains in that Nikrent driving Marmon 25, passed Barnes. In lap eight it was Mercer, Marmon, Mercer, Marmon,

Mercer. Lap nine saw the same order of running continue and Knipper's Mercer was taken out, the trouble not being known. In lap ten the order remained unchanged. Lap eleven saw the Barnes Mercer take second place away from Heineman's Marmon, holding the place in lap twelve, but losing it in lap thirteen, the last of the race, so that when it was over the order was Mercer, Marmon, Marmon, the Barnes Mercer not showing up at the end of the race.

The fastest lap in the race was made by the Barnes Mercer in the eighth circuit in 14:11 or over 70 miles per hour. The winning Mercer made one stop, in lap nine, to take on gasoline and oil and repair a hinge in the bonnet. Heineman stopped for 10 seconds in lap twenty-one to take on a tire to replace one changed on the backstretch.

### E-M-F One-Two-Three in Tiedeman

To-day's race for the Tiedeman trophy, ten laps, 171.40 miles, was won by E-M-F machines that finished one, two and three, the only other car running at the finish being the Ford (Kulick). Two Abbott-Detroits were entered, but No. 32 went out in the second lap with a cracked cylinder and No. 31 in the seventh with a broken valve rocker arm. There were six starters and the race was started immediately after the Savannah cup, the first car in the Tiedeman starting 30 seconds after the last of the Savannah.

The three E-M-F cars made a remarkable showing, all finishing within a 3-minute zone. The winner, No. 35, driven by Frank Witt, made the 171.40 miles in 176 minutes and 19 seconds. No. 34, driven by Robert Evans, was second in 180 minutes 12 seconds and No. 33 third, in 181 minutes 33 seconds. Kulick, in the Ford, covered the distance in 201 minutes 7 seconds. The fastest lap in the race was made by Mortimer Roberts, in No. 31 Abbott, being 16.23 or 63 miles per hour. When Roberts dropped out in the seventh lap he was 7 minutes in the lead, with the three E-M-F's in second, third and fourth place.

**FOR THE TIEDEMAN TROPHY, 10 LAPS, 171.40 MILES.**

3	4	5	6	7	8	9	10
51.43	68.56	85.70	102.84	119.98	137.12	154.26	171.40
54:02	71:46	89:15	106:45	124:07	141:24	158:48	176:23.34
18:16	17:44	17:29	17:30	17:22	17:17	17:20	17:35
54:48	72:33	90:16	108:01	125:46	144:37	162:25	180:12.34
17:53	17:45	17:43	17:45	17:45	18:51	17:48	17:47
56:01	74:19	92:33	110:23	128:16	146:03	163:46	181:33.84
18:16	18:18	18:14	17:50	17:53	17:47	17:43	17:47
58:47	83:18	100:54	119:55	139:25	157:31	180:36	201:07.50
19:07	25:01	17:36	19:01	19:30	18:06	23:05	
49:17	65:49	82:29	99:16				
16:30	16:32	16:40	16:47				



Banked turn into Ferguson Road from Montgomery Road



The repair gangs were kept busy right up to the hour of starting

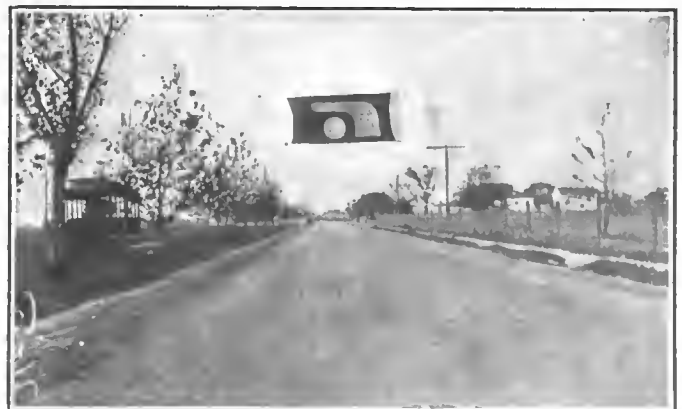

Nearing the end of the beautiful stretch on Waters Road



Nikrent in the Marmon doing a fast lap over the course



Harry Cohe giving his Vanderbilt Jackson a fast tryout

When it came to a race among the three E-M-F machines No. 35 took the lead and maintained it, the other two not changing their places. They all ran consistently, as an analysis of their lap times will show.

The small car races proved most interesting, more interesting perhaps than had generally been expected. The Mercer-Marmon duel in the Savannah was almost as fascinating as the fight between the winner and the foreign contenders in the Vanderbilt

race. The fact that in the Savannah race two American teams battled for the trophy, and that Hughes' Mercer that did so much excellent work during the past season, finally finished as the victor did much toward arousing the enthusiasm of the spectators. The victory of the E-M-F in the Tiedeman Trophy event, however commendable, did not come quite unexpected, the car having shown its great strength and speed earlier this year, especially on the Brighton Beach track.

**TABLE SHOWING FASTEST LAPS IN SAVANNAH RACE**

No.	Car.	Lap Time	Lap Time	Lap Time	Lap Time	Fastest Lap M.P.H.
22	Mercer	6-14.47	7-14.49	5-14.51	8-14.53	71.2
21	Marmon	3-15.12	5-15.12	4-15.13	7-15.14	68.0
25	Marmon	6-15.26	7-15.29	8-15.30	5-15.32	67.2
24	Mercer	8-14.11	3-14.50	2-14.55	4-15.17	73.0
23	Case	5-18.39	4-18.45	7-18.50	3-18.56	56.0
27	Mercer	6-15.03	7-15.06	4-15.08	2-15.09	68.3
26	Case	2-14.42	3-14.48	4-14.53	1-14.56	71.2

**POSITION OF SAVANNAH CARS AT END OF EACH LAP**

No.	Car and driver	1st	2d	3d	4th	5th	6th	7th	8th	9th	10th	11th	12th	13th
22	Mercer, Hughes...	2	3	3	2	1	1	1	1	1	1	1	1	1
21	Marmon, Heineman	5	5	5	4	3	3	2	2	2	3	3	2	
25	Marmon, Nikrent...	6	6	6	6	5	5	4	4	4	4	4	3	
24	Mercer, Barnes...	4	2	2	3	2	4	5	3	3	3	2	2	
23	Case, Buckley...	7	7	7	7	6	6	6	6	5	5			
27	Mercer, Knipper...	3	4	4	4	3	2	2	5					
26	Case, Dishrow...	1	1	1	1									

**FASTEST INDIVIDUAL LAPS IN RACE FOR TIEDMAN TROPHY**

No.	Car	Lap Time	Lap Time	Lap Time	Lap Time	Fastest Lap M.P.H.
31	Ahhott-Detroit	1-16.23	2-16.24	3-16.30	4-16.32	63
35	E.M.F.	8-17.17	9-17.20	7-17.22	5-17.29	59.8
36	Ford	5-17.36	8-18.06	2-18.57	6-19.01	59.2
33	E.M.F.	9-17.43	8-17.47	6-17.50	7-17.53	57.6
34	E.M.F.	5-17.43	4-17.45	6-17.45	7-17.45	57.6
32	Ahhott-Detroit	1-18.04				57

**TABLE SHOWING POSITIONS OF CARS IN EACH LAP OF TIEDMAN RACE**

No.	Car and Driver	1st	2d	3d	4th	5th	6th	7th	8th	9th	10th
35	E.M.F., F. Witt	2	2	2	2	2	2	1	1	1	1
34	E.M.F., R. Evans	4	3	3	3	3	3	2	2	2	2
33	E.M.F., J. Tower	5	4	4	4	4	4	3	3	3	3
36	Ford, F. Kulick	6	5	5	5	5	5	4	4	4	4
31	Ahhott-Detroit, M. Roberts	1	1	1	1	1	1				
32	Ahhott-Detroit, R. Hartman	3									

**Georgia Tour a Success**

SAVANNAH, GA., Nov. 25—With only two penalizations, both of 1,000 points for withdrawal, the Tour Around Georgia reached here this afternoon, the contestants covered with the white dust of the shell roads of Southern Georgia. The penalized cars are: the Buick, No. 50, which was side-swiped and overturned by a passing car near Americus on the first day's run, and the Dorris, No. 17, which broke a wheel just outside Baxley on the third day's run.

The tourists left Atlanta, Nov. 22 and checked in at Americus, the first night stop. The second day's run brought them to Valdosta and the third to Baxley, to-day's trip from Baxley to this city making the total mileage 502.4. At each stop the cars received a rousing welcome and on their arrival here this afternoon were escorted into the city by a band and a large number of automobiles.

After the Grand Prize race the tourists will make the return trip to Atlanta a two-days' run, checking out here December 1.

**Annual Banquet of L. I. A. C.**

The Long Island Automobile Club, Prospect Park Plaza, Brooklyn, will hold its annual dinner at the clubhouse on Wednesday evening, December 6. It will be served by a well-known caterer, and arrangements are now being made to have a good vaudeville follow.

**Free Entry for Foreign Racing Cars**

WASHINGTON, D. C., Nov. 27—The secretary of the treasury has informed collectors of customs that the following articles of the customs regulations of 1908 have been amended to read as follows:

"Article 595. Motor cars, motorcycles, etc., and accessories, of foreign origin imported into this country by the owners personally for bona-fide touring purposes only, provided such owners are non-residents of the United States, are entitled to free entry under bond for a stay of six months; provided, however, that such owner shall present at the time of making entry a certificate from the United States consul at the port of exportation, based upon the sworn statement of the owner, to the effect that the said article is brought to this country for touring purposes only and that the same is not to be used for any commercial purposes or business pursuits whatsoever while in the United States. The articles enumerated may accompany the owner or arrive within 30 days before or after his arrival.

"Article 596. Motor cars, motorcycles, motor-boats, etc., brought into this country by non-residents of the United States, for the purpose of racing or taking part in other specific contests are entitled to free entry under bond for a stay of not exceeding six months, but cannot be admitted hereunder for display in shows or exhibitions of any kind, nor for any commercial or trade purposes whatsoever. Such purposes shall be evidenced by the oath of the owner or his agent made before the United States consul at the port of exportation and by him certified, and presented at the time of entry."

**Self-Starting Commercial Car**

PHILADELPHIA, PA., Nov. 27—The Philadelphia Truck, the latest addition to the commercial vehicle line, was placed on exhibition to-day at A. G. Spalding's on Broad street, above Race.

The Philadelphia truck is equipped with an electric self-starting device, and is the product of the Philadelphia Truck Co.

# Official Records of A. A. A. for 1911

## STRAIGHTAWAY FREE-FOR-ALL, REGARDLESS OF CLASS

Distance	Time	Driver	Car	Place	Date
1 kilo...	15.88	Burman	Blitzen Benz	Daytona	Apr. 23, 1911
1 mile...	25.40	Burman	Blitzen Benz	Daytona	Apr. 23, 1911
2 miles...	51.28	Burman	Blitzen Benz	Daytona	Apr. 23, 1911
5 miles...	2:34	Hemery	Darracq	Daytona	Jan. 24, 1906
10 miles...	5:14 2-5	Bruce-Brown	Benz	Daytona	Mar. 24, 1909
15 miles...	10:00	Lancia	Fiat	Daytona	Jan. 29, 1906
20 miles...	13:11.92	Burman	Buick Bug	Jacksonville	Mar. 30, 1911
50 miles...	35:52.31	Burman	Buick Bug	Jacksonville	Mar. 28, 1911
100 miles...	1:12:45 1-5	Bermin	Renault	Daytona	Mar. 6, 1908
150 miles...	1:55:18	Disbrow	Special	Jacksonville	Mar. 31, 1911
200 miles...	2:34:12	Disbrow	Special	Jacksonville	Mar. 31, 1911
250 miles...	3:14:55	Disbrow	Special	Jacksonville	Mar. 31, 1911
300 miles...	3:53:33.50	Disbrow	Special	Jacksonville	Mar. 31, 1911
81.65 miles...	One Hour				Mar. 28, 1911

### (Standing Start)

1 mile...	40.53	Oldfield	Benz	Daytona	Mar. 16, 1910
-----------	-------	----------	------	---------	---------------

## CLASS "B" STRAIGHTAWAY RECORDS (STOCK CHASSIS)

161 to 230 Cubic Inches					
Distance	Time	Driver	Car	Place	Date
5 miles...	4:24.13	Towers	War-Detroit	Jacksonville	Mar. 29, 1911
10 miles...	9:10.52	Towers	War-Detroit	Jacksonville	Mar. 30, 1911
231 to 300 Cubic Inches					
10 miles...	8:16.35	Wilson	Cole	Jacksonville	Mar. 29, 1911
301 to 450 Cubic Inches					
1 kilo...	26.75	Merz	National	Jacksonville	Mar. 29, 1911
1 mile...	40.32	Wilcox	National	Jacksonville	Mar. 30, 1911
5 miles...	3:56.82	Wilcox	National	Jacksonville	Mar. 30, 1911
10 miles...	8:03.67	Merz	National	Jacksonville	Mar. 29, 1911

## SPEEDWAY RECORDS, REGARDLESS OF CLASS

Distance	Time	Driver	Car	Place	Date
1/4 mile...	8.16	Burman	Blitzen Benz	Indianapolis	May 29, 1911
1/2 mile...	16.80	Burman	Blitzen Benz	Indianapolis	May 29, 1911
1 kilo...	21.40	Burman	Blitzen Benz	Indianapolis	May 29, 1911
1 mile...	35.35	Burman	Blitzen Benz	Indianapolis	May 29, 1911
2 miles...	1:15.96	Bragg	Fiat	Los Angeles	Apr. 13, 1910
5 miles...	3:15.62	De Palma	Fiat	Los Angeles	Apr. 8, 1910
10 miles...	6:35.62	Robertson	Simplex	Los Angeles	Apr. 9, 1910
15 miles...	10:25.17	Hearne	Benz	Indianapolis	July 4, 1910
20 miles...	14:06.72	Hearne	Benz	Indianapolis	July 4, 1910
25 miles...	18:22.60	Tetzlaff	Lozier	Los Angeles	Mar. 19, 1911
50 miles...	36:35.80	Tetzlaff	Lozier	Los Angeles	Mar. 19, 1911
75 miles...	54:50.20	Tetzlaff	Lozier	Los Angeles	Mar. 19, 1911
100 miles...	1:14:29.20	Tetzlaff	Lozier	Los Angeles	Mar. 19, 1911
150 miles...	1:57:15	Bruce-Brown	Piat	Indianapolis	May 30, 1911
200 miles...	2:39:28	Bruce-Brown	Piat	Indianapolis	May 30, 1911
250 miles...	3:17:49	Bruce-Brown	Piat	Indianapolis	May 30, 1911
300 miles...	4:01:25	Harroun	Marmon	Indianapolis	May 30, 1911
350 miles...	4:42:38	Mulford	Lozier	Indianapolis	May 30, 1911
400 miles...	5:23:15	Harroun	Marmon	Indianapolis	May 30, 1911
450 miles...	6:03:01	Mulford	Lozier	Indianapolis	May 30, 1911
500 miles...	6:42:08	Harroun	Marmon	Indianapolis	May 30, 1911

### (Hour Records)

74 miles...	1:00:00	Harroun	Marmon	Los Angeles	Apr. 16, 1910
148 miles...	2:00:00	Harroun	Marmon	Los Angeles	Apr. 16, 1910

## ONE MILE CIRCULAR DIRT TRACK RECORDS

Distance	Time	Driver	Car	Place	Date
1 mile...	48.62	Burman	Blitzen Benz	Brighton B'h.	Sept. 4, 1911
2 miles...	1:37.89	Burman	Blitzen Benz	Brighton B'h.	Sept. 2, 1911
3 miles...	2:30.55	De Palma	Fiat	Syracuse	Sept. 17, 1910
4 miles...	3:22.27	De Palma	Fiat	Syracuse	Sept. 17, 1910
5 miles...	4:11.90	De Palma	Fiat	Syracuse	Sept. 17, 1910
10 miles...	8:31 1-5	De Palma	Fiat	Narbeth, Pa.	Sept. 24, 1910
15 miles...	13:41.40	Oldfield	Darracq	Milwaukee	Sept. 27, 1910
20 miles...	18:15	Oldfield	Darracq	Milwaukee	Sept. 27, 1910
25 miles...	22:47	Oldfield	Darracq	Milwaukee	Sept. 27, 1910
50 miles...	47:21.65	De Palma	Simplex	Syracuse	Sept. 16, 1911
75 miles...	1:19:39	Strang	Buick	Columbus, O.	July 3, 1909
100 miles...	1:41:00 2-5	Burman	Buick	Columbus, O.	July 3, 1909

## CLASS "B" SPEEDWAY RECORDS

(Stock Chassis, Piston Displacement, Minimum Weight)

451 to 600 Cubic Inches					
Distance	Time	Driver	Car	Place	Date
5 miles...	4:01.36	Oldfield	Knox	Indianapolis	May 30, 1910
10 miles...	7:47.71	Robertson	Fiat	Atlanta	Nov. 11, 1909
20 miles...	15:57.41	De Palma	Fiat	Atlanta	May 5, 1910
50 miles...	42:02.98	Robertson	Fiat	Atlanta	Nov. 13, 1909
100 miles...	1:22:35.35	Robertson	Fiat	Atlanta	Nov. 13, 1909
150 miles...	2:05:00.63	Robertson	Fiat	Atlanta	Nov. 13, 1909
200 miles...	2:53:48.32	Disbrow	Rainier	Atlanta	Nov. 13, 1909
301 to 450 Cubic Inches					
5 miles...	4:05.76	Kincaid	National	Indianapolis	May 27, 1910
10 miles...	7:55.12	Aitken	National	Indianapolis	July 2, 1910
15 miles...	11:48.78	Aitken	National	Indianapolis	July 1, 1910
20 miles...	15:57.63	Dawson	Marmon	Indianapolis	May 27, 1910
50 miles...	39:47.35	Dawson	Marmon	Atlanta	Nov. 3, 1910
75 miles...	1:00:16.34	Dawson	Marmon	Indianapolis	May 27, 1910
100 miles...	1:23:43.11	Kincaid	National	Indianapolis	May 27, 1910
150 miles...	2:05:02.17	Chevrolet	Buick	Atlanta	Nov. 9, 1909
200 miles...	2:46:48.47	Chevrolet	Buick	Atlanta	Nov. 9, 1909
250 miles...	4:38:57.4	Burman	Buick	Indianapolis	Aug. 19, 1909

## 231 to 300 Cubic Inches

Distance	Time	Driver	Car	Place	Date
5 miles...	4:16	Dawson	Marmon	Indianapolis	July 2, 1910
10 miles...	8:16.08	Harroun	Marmon	Indianapolis	May 27, 1910
20 miles...	17:10.70	Chevrolet	Buick	Atlanta	Nov. 11, 1909
25 miles...	21:48.92	Harroun	Marmon	Indianapolis	May 30, 1910
50 miles...	42:41.33	Harroun	Marmon	Indianapolis	May 30, 1910
75 miles...	67:31.07	Harroun	Marmon	Atlanta	Nov. 11, 1909
100 miles...	1:30:08.31	Harroun	Marmon	Atlanta	Nov. 11, 1909

## 161 to 230 Cubic Inches

Distance	Time	Driver	Car	Place	Date
4 miles...	3:49	Witt	E-M-F	Atlanta	Nov. 3, 1910
5 miles...	4:35.47	L. Chevrolet	Buick	Indianapolis	July 2, 1910
10 miles...	8:55.40	L. Chevrolet	Buick	Indianapolis	July 2, 1910
20 miles...	19:51	Knipper	Chalmers	Atlanta	Nov. 12, 1909
50 miles...	50:36	Nelson	Buick	Atlanta	Nov. 9, 1909
100 miles...	1:40:46.81	Knipper	Chalmers	Atlanta	Nov. 10, 1909

## 160 Cubic Inches and Under

Distance	Time	Driver	Car	Place	Date
1 mile...	0:56.80	Witt	Flanders	Indianapolis	Nov. 13, 1911
5 miles...	4:22.98	Witt	Flanders	Indianapolis	Nov. 13, 1911
10 miles...	9:27.49	Witt	Flanders	Indianapolis	Nov. 13, 1911
15 miles...	14:13.26	Witt	Flanders	Indianapolis	Nov. 13, 1911
20 miles...	19:00.87	Witt	Flanders	Indianapolis	Nov. 13, 1911

## CLASS "C" SPEEDWAY RECORDS

(No Restriction Other Than Piston Displacement)

160 Cubic Inches and Under					
Distance	Time	Driver	Car	Place	Date
5 miles...	4:26.08	Evans	Flanders	Indianapolis	Nov. 13, 1911
10 miles...	8:53.97	Evans	Flanders	Indianapolis	Nov. 13, 1911
15 miles...	13:24	Evans	Flanders	Indianapolis	Nov. 13, 1911
20 miles...	17:54.82	Evans	Flanders	Indianapolis	Nov. 13, 1911
161 to 230 Cubic Inches					
5 miles...	4:20.20	J. Nikrent	Buick	Los Angeles	Apr. 15, 1910
10 miles...	8:40.17	J. Nikrent	Buick	Los Angeles	Apr. 15, 1910
15 miles...	13:14.52	J. Nikrent	Buick	Los Angeles	Apr. 9, 1910
20 miles...	17:37.36	J. Nikrent	Buick	Los Angeles	Apr. 9, 1910
25 miles...	21:41.37	Anthony	Regal	Los Angeles	Oct. 21, 1911
50 miles...	43:49.69	Endicott	Cole	Los Angeles	Apr. 9, 1910
231 to 300 Cubic Inches					
5 miles...	3:55.97	Harroun	Marmon	Los Angeles	Apr. 10, 1910
10 miles...	7:47.20	Hanshue	Mercer	Los Angeles	Oct. 21, 1911
15 miles...	12:59.95	Siefert	Dorris	Los Angeles	Apr. 8, 1910
20 miles...	17:15.47	Harroun	Marmon	Los Angeles	Apr. 8, 1910
25 miles...	19:48.97	Jeffkins	Schacht	Los Angeles	Oct. 22, 1911
50 miles...	42:30.08	Siefert	Dorris	Los Angeles	Apr. 8, 1910
75 miles...	1:03:54.28	Siefert	Marmon	Los Angeles	Apr. 8, 1910
100 miles...	1:25:22.07	Harroun	Marmon	Los Angeles	Apr. 8, 1910
301 to 450 Cubic Inches					
5 miles...	3:49.36	J. Nikrent	Buick	Los Angeles	Apr. 17, 1910
10 miles...	7:36.61	J. Nikrent	Buick	Los Angeles	Apr. 17, 1910
15 miles...	12:04.99	Dawson	Marmon	Los Angeles	Apr. 15, 1910
20 miles...	16:04.40	Harroun	Marmon	Los Angeles	Apr. 15, 1910
25 miles...	20:08.69	Harroun	Marmon	Los Angeles	Apr. 15, 1910
50 miles...	39:53.55	Harroun	Marmon	Los Angeles	Apr. 15, 1910
451 to 600 Cubic Inches					
5 miles...	3:38.61	Oldfield	Knox	Los Angeles	Apr. 16, 1910
10 miles...	7:20.66	Oldfield	Knox	Los Angeles	Apr. 16, 1910
15 miles...	11:32.34	Marquis	Isotta	Los Angeles	Apr. 10, 1910
20 miles...	15:29.18	Marquis	Isotta	Los Angeles	Apr. 10, 1910
25 miles...	19:24.92	Marquis	Isotta	Los Angeles	Apr. 10, 1910
50 miles...	39:20.09	Marquis	Isotta	Los Angeles	Apr. 10, 1910

## 24-HOUR TRACK RACES

Stock Chassis...	Lozier	Patschke & Mulford	1,196 mi.	Br'ton B'h.	Oct. 15, 1909
Class "C"...	Stearns	Poole & Patschke	1,253 mi.	Br'ton B'h.	Oct. 19, 1910
Cl. "C" Spdwy...	Fiat	Verbeck & Hirsh	1,491 mi.	Los Ang's.	Apr. 8, 1911

## 1911 ROAD RACES

Panama-Pacific, February 22, 1911

Classification	Car	Driver	Distance	Time	M.P.H.
161-230 Class C...	Ford	O'Brien	Running when Race called.		
231-300 Class C...	Mercer	Bigelow	98.307	1:02:54	57.32
301-600 Class C...	National	Merz	152.922	1:37:20	66.81
Free-for-all...	P-Hart'd.	Dingley	163.845	1:49:30	65.75

Bakersfield, California, July 4, 1911

Under 300 Class C...	Buick	L. Nikrent	100.35 m.	1:35:34.60	44.41
Free-for-all...	National	Herrick	156.1 m.	2:18:58.20	52.33

Elgin National, Elgin, Ill., Aug. 25-26, 1911

Under 600 st. chas.	National	Zengel	305 m. 204 ft.	2:27:39.08	66.38
301-450 st. chas.	National	Herr	203 m. 1896 ft.	1:85:55	65.628
231-300 st. chas.	Mercer	Hughes	169 m. 2460 ft.	1:57:21.52	64.616
161-230 st. chas.	Ab-Detroit	Roberts	135 m. 3024 ft.	1:51:11.32	53.802

Fairmount Park Road Race, Philadelphia, Pa., October 9, 1911

601-750 cl. C. div. 6C	Benz	Bergdoll	202.5	1:98:41.35	61.149
451-600 cl. C. div. 5C	Lozier	Mulford	202.5	2:01:52.78	60.18
301-450 cl. C. div. 4C	National	Disbrow	202.5	2:08:22.32	58.308
231-300 cl. C. div. 3C	Mercer	Hughes	202.5	2:09:45.30	57.916

Cincinnati Fern Bank Dam Road Race Cincinnati, O., Sept. 9, 1911	Under 600 Class C...	Fiat	Hearne	197.5 m.	2:09:03.20	56.682
	Under 300 Class C...	Cole	Jenkins	150.1 m.	1:66:29	54.09

Santa Monica (Calif.) Road Race, October 14, 1911

Under 230 Class C...	Buick	L. Nikrent	101.004 m.	1:02:21.70	59.20
231-300 Class C...	Marmon	Keene	151.506 m.	1:32:09.95	68.78
301-450 Class C...	National	Merz	151.506 m.	1:22:08.45	74.4228
Free-for-all...	National	Herrick	202.008 m.	1:62:24.60	74.628

Desert Race, Los Angeles and Phoenix, November 4-6, 1911

Free-for-all...	National	Herrick	551	12:23	27.03
-----------------	----------	---------	-----	-------	-------



# Civic Pride in Davidson County, and

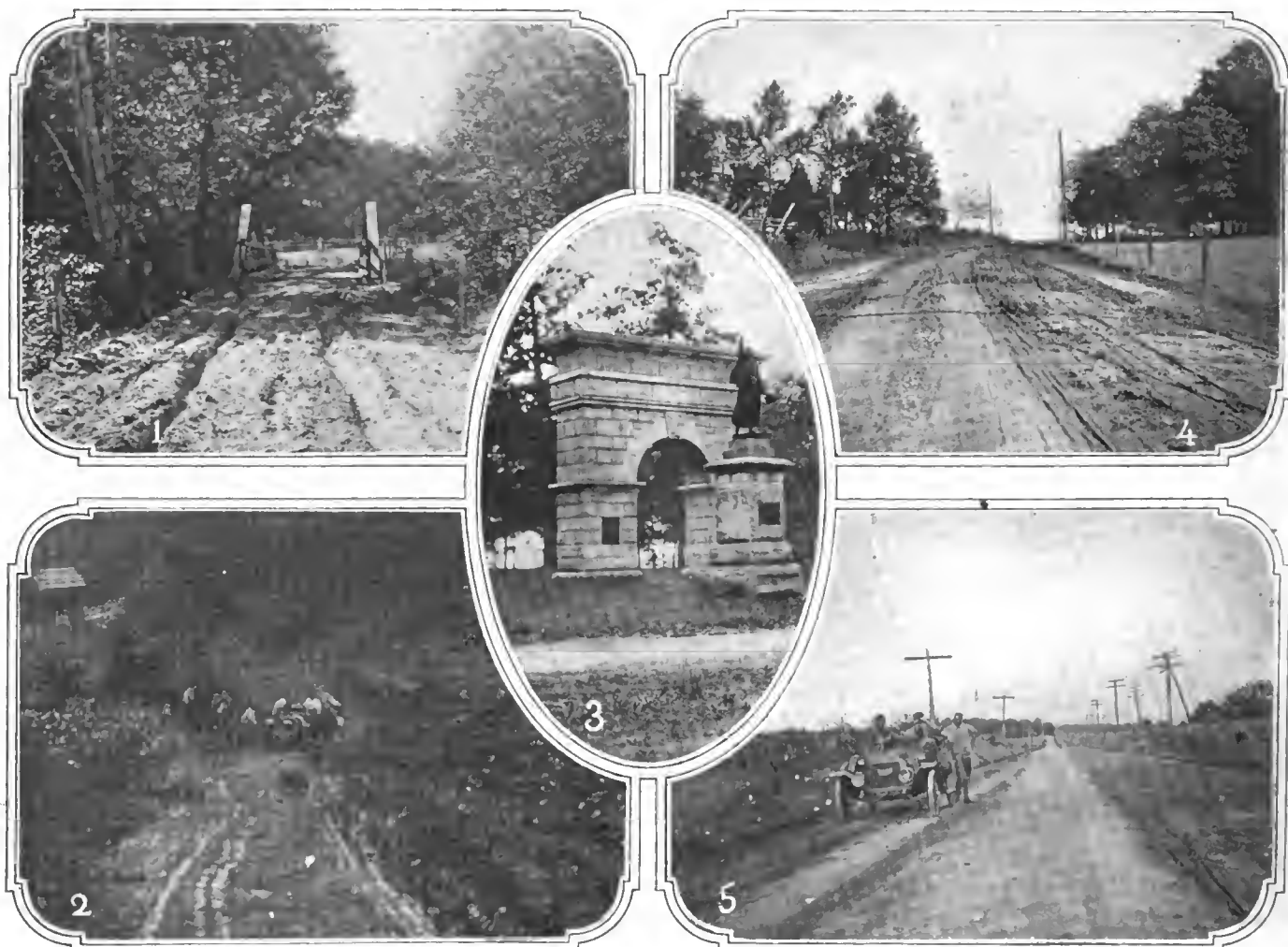

1—One of Davidson County's contributions to Glidden tour misery

3—Revolutionary War memorial arch erected

2—The State is level, but in the north some heavy grades are found

4—Red clay road near Oak Ridge, an excellent example of the State roads on the battlefield of Guilford Court House

5—For 10 miles into Charlotte the macadam roadway is almost perfect

**P**RECONCEIVED impressions of North Carolina, held by the average Northerner, are far from the mark. Those who have not had the privilege of a recent visit to the Old North State, as it is affectionately called by its residents and neighbors, possess only the most shadowy ideas as to actual conditions that obtain there. In many ways North Carolina is the most advanced of the Southern States. Instead of being poverty-stricken, ignorant and narrow, it is doubtful if better general conditions of living obtain anywhere in the country.

Tobacco, cotton and corn grow abundantly and in high quality almost everywhere in North Carolina; the manufacturing of cloth and yarns and furniture and tobacco is voluminous; retail and wholesale merchandising is large in volume and prosperous and in every way the State is full of life. Needless to say, the roads of North Carolina are good.

The tobacco mills at Winston-Salem are among the greatest in the world; the furniture factories at High Point turn out a product that rivals Grand Rapids and the cotton mills of Charlotte are stupendous in size and turn-out.

It is said that child labor in the mills is a menace and it probably is, but that is an economic problem and like all other economic problems it can be worked out only through evolution and

the general advancement of education. Curious as it may seem the automobile is not in common use. In the big centers of population there are quite a number of cars, but many of the medium-priced lines are not handled at all or are handled in a desultory sort of way not likely to increase their popularity.

In Winston-Salem for instance, where there is abundant prosperity and plenty of money that could be used in the purchase and operation of automobiles, the industry is not what it should be. There is a big field in North Carolina for the agent of any of the moderate-priced lines who will devote as much time and energy to his business as he would have to in any other locality to achieve success.

He has the best argument in the world for making sales—good roads. He has to deal with a real potential buying power, for the money is there. The people understand the value of transportation, because the theorem has been demonstrated to them so often and so conclusively. To the farmer who used to be able to haul a single bale of cotton to market over roadless wastes, no further argument is necessary after pointing out that he can now haul five bales with the same horsepower at much higher speed, using the roads that were born when the automobile came into vogue.



# Hotels, Are North Carolina's Needs

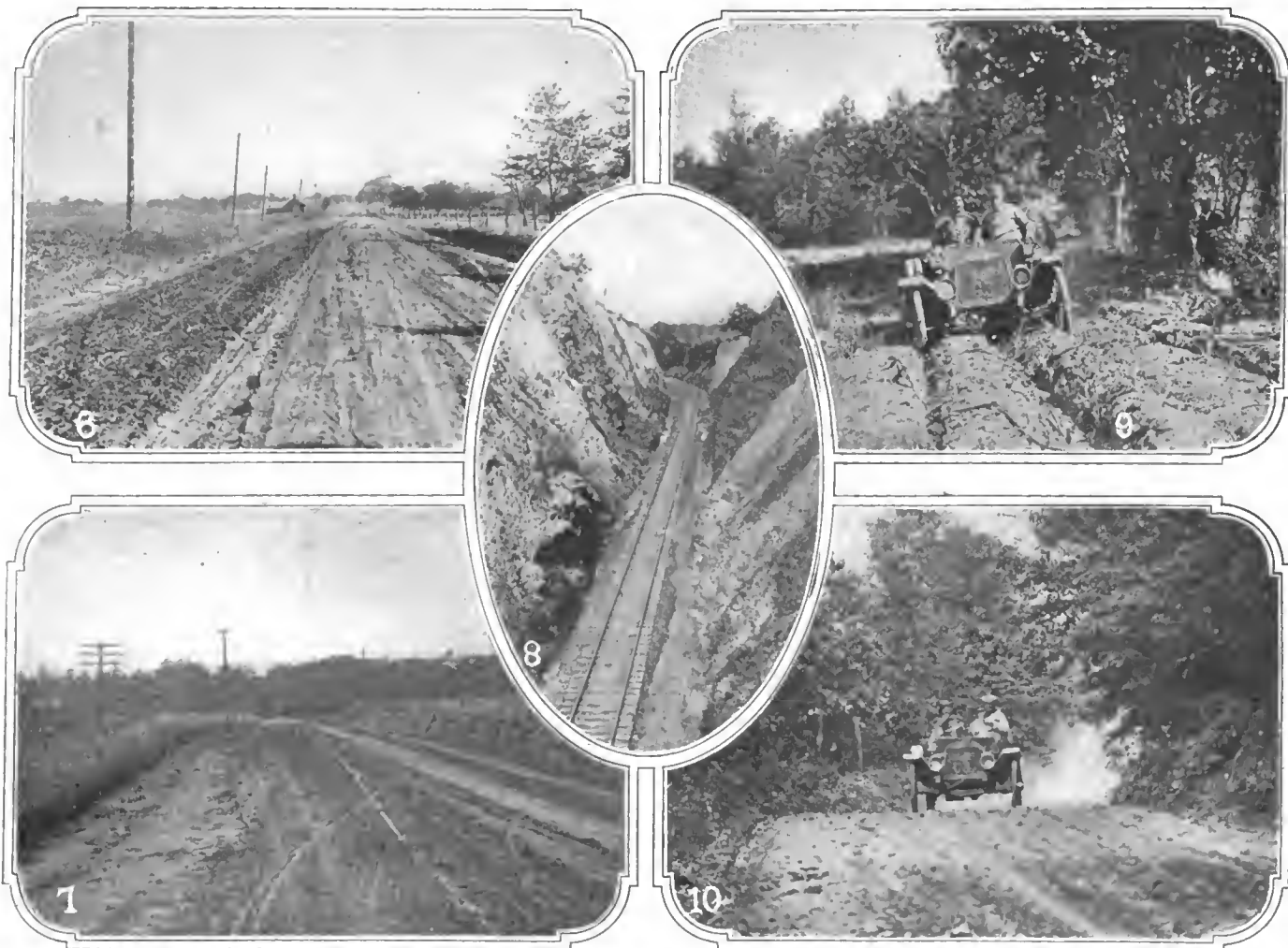

6—Example of recently constructed highway south of Summerfield

8—Railroad cut through King's Mountain,

7—Here is a typical road scene—this picture was taken near Gastonia

9—The trip into Lexington is not exactly the best in the world corresponding to the highway improvement

10—Grades and rough spots are to be found in entering Stonesville

The Old North State is at one disadvantage, however, in its road making. Stone is scarce, and as a consequence a mixture of clay and sand represents the commonest and most available surfacing material. This makes an excellent road and with proper grading and scraping at intervals, answers present purposes very well indeed.

There is only one real bad spot in the State, and it is a disgrace. Davidson County, N. C., will long be remembered by the participants in the recent Glidden Tour for its frightful highways. The city of Lexington, situated in the center of the celebrated Piedmont region, is the county seat of Davidson County. On both sides of Lexington the roads are rough and neglected. No effort has been made for years to improve conditions. There is one place north of the city where the road crosses a savage mud-hole that could be bridged for a few thousand dollars, where traffic is almost impossible. It has been estimated by some of the progressive people of Lexington that this one mud-hole costs the local industries something in excess of \$100,000 a year by diverting produce from its natural center.

A bridge costing not more than \$4,000 and work on the roads calling for not more than \$200 per mile per year, or a total initial expenditure of \$6,000 and an annual expense of not more

than \$2,000 a year thereafter, would mean at least \$100,000 more to the city of Lexington. If in addition, \$10,000 a year could be used in permanent and current road improvements from side to side of Davidson County to better the main north and south highway traveled by the Glidden Tour, it is as certain as mathematics, that the profits of Lexington would run close to \$1,000,000 a year more than they do under present conditions.

Commencing at the Virginia State line, the mileage of the main road across North Carolina to Grover, just north of the South Carolina line, is 237.5, traveling by the way of Winston-Salem, Greensboro, High Point, Thomasville, Lexington, Salisbury, Concord and Charlotte.

All but about 25 miles in Davidson County consists of good roads. Of these probably 80 miles is of domestic macadam of high quality and the remainder is of graded sand-clay roads that are excellent, any way one looks at, or uses them. Generally speaking these roads are 14 or 16 feet wide and smooth as a floor. In wet weather there is just enough traction to make going easy owing to the sand mixed with the clay, and not enough to destroy tires like the average sand road.

The highway enters North Carolina just before reaching Price Station, 48 miles north of Winston-Salem. When the Glidden



Iron bridge crossing the Catawba River after leaving Spurriers

Tour passed that way it was black night and the first few miles into the Old North State were quite a trial. The road is rough for 5 miles. Just plain, rough, but upon coming to Stoneville a gradual improvement is felt. The road broadens and is straighter and all around more agreeable for touring. From Stoneville to Madison, about 7 miles, the improvement continues and after passing the Dan River the highway sweeps to the South practically straight through the pine forests, swerving only occasionally to round some swelling hillock. There is some little sand to be traversed before reaching Stokesdale, 12 miles to the South, but from that point to Kernersville the way is smooth and fine over graded clay roads of the type that makes up most of the way across the State. Kernersville is about 11 miles from Winston-Salem and the road between consists of excellent macadam.

The Gliddenites made a spectacular run from Kernersville to Winston-Salem. The road is generally 20 feet wide and is in excellent condition. Most of the cars were from 10 minutes to 30 minutes late when they passed Kernersville and the wild sprint to control was the big feature of the tour. Lighted only by their headlamps, the caravan picked out the white macadam with ease and as much as 60 miles an hour was made by some of the more powerful contestants in an effort to avoid penalization. The road lent itself to just such a sprint and the sight from the checking station down the long, gentle incline that approached it, was wonderful.

Winston-Salem is the big, virile combination of two cities, Winston and Salem and is one of the liveliest cities of its class touched on the route to the South. Its tobacco factories are gigantic in size and product and it has a sufficiently diversified industry to insure permanent prosperity. As an educational center the place is noted and one of the features of the reception tendered the Gliddenites was the presence of a throng of beautiful girls, students and graduates of the seminaries located there. Winston-Salem has an excellent hotel, something exceedingly rare south of Mason and Dixon's line. It is far in advance of anything encountered by the tourists in Virginia or in fact anywhere between Philadelphia and Atlanta.

Leaving this agreeable place, the route follows the same splendid stretch of macadam to Kernersville that was traversed in approaching the city, but 2 miles further along the road forks and the right fork leads into the main road to Charlotte. Next Spring it is expected that a macadam highway to Lexington via Midway will be completed, which will cut off 50 miles. This road is passable now, but was not used during the Glidden tour.

The macadam, which was left at Kernersville, commences again at Oak Ridge, 7 miles beyond that place, and continues to Greensboro by the circuitous route pursued. This part of the

way passes through Summerfield and Guilford Court House, noted as a bloody battlefield of the Revolutionary war. Memorial arches stand upon the battlefield, and in the quaint cemeteries near the little town there are numerous headstones bearing the names



Long, shaky trestle, leading up to a creek in the woods south of Salisbury of heroes whose memories are cared for in the rolls of our national history. Here and there among them are memorials to British officers who fell in the big battle and during the campaign that was waged to hold North Carolina to her allegiance to England.

Greensboro is a thriving place which has much manufacturing of various sorts and a rich agriculture. It is one of the best centers in the state for automobiles, as may be surmised from the fact that the roads thereabouts have been awarded first prizes for excellence and a few miles below the city there is a fine, strong bridge that was built by the enterprising citizenship with the prize money that was awarded for their good roads.

High Point, the next considerable town on the route, is 52.2 miles from Winston-Salem by the winding road. This place contains sixty-nine furniture factories and is bubbling full of life and energy. As an instance of its willingness to receive publicity it may be cited that the Glidden Tour was halted for 30 minutes while delicious coffee and sandwiches were distributed through the train of automobiles. Needless to say, the impression created was pleasant. But there are other things about High Point to be commended beside its hospitality. The roads are models of construction and maintenance, the place looks well-groomed and the people seem comfortable. It is said

that solid train loads of furniture are shipped from High Point to the wholesale distributing centers of the United States and that the place will prove more and more of a competitor of Grand Rapids in the markets of the world as the years pass.

But after leaving High Point there is a different story to tell. About 3 1-2 miles to the south the macadam ends with a jerk that nearly threw overboard some of the non-cautious passengers on the tour. On the general average the road into Thomasville may be reckoned fair, but after leaving that place, 61 miles from Winston-Salem, the road grows rapidly no better. There is a rather steep climb that commences 6 miles south of Thomasville and continues up and down all the way to Lexington. In the hills the roads are not so bad, but at the bottoms of the inclines the roads were never intended for automobiles, and much less for any other kind of traffic, especially in wet weather.

There is one particularly vicious spot that is encountered 1-2 mile after beginning the climb. The road makes a half circle, following the hillside, and then shoots south across the flat. In the middle of the short stretch that lies between the bottom and the next up-grade, there is a mud-hole about 100 feet across. No bottom was found for this in spots and many of the cars tried to discover it. Broken wheels, steering gear and sprung axles will be the lot of the motorist who tries to negotiate this

its disrepair lies in the fear that a few bales of cotton might be hauled into High Point or Greensboro from points to the south of Lexington, rather than to market in that city. At any rate such cotton will continue to be marketed at Lexington until the mud-hole is bridged adequately, although it is quite likely that thousands of wagon-loads of produce raised to the north of the obstruction will not make any desperate efforts to come to market at Lexington as long as the mud-hole exists in its present condition.

The roads through Davidson County were built by the soldiers of General Greene's army during the Revolution and most of them look as if they had never been touched since that lamented officer passed away. As might be expected, there are numerous fords in Davidson County and a toll gate or two, where the roads are worst.

Salisbury, N. C., is quite a different kind of a place, situated in quite a different sort of a county. As soon as Davidson County is left behind, the roads show a startling improvement. From Salisbury to Concord, a distance of 22 1-2 miles, the route is over graded clay and fine macadam, the latter being found for a mile on either side of all the settlements of any size and continuously for miles on entering and leaving the larger places. Salisbury gave the tour a warm welcome and did its best to make up in hospitality what it lacked in accommodations.

The final 27 miles of the run into Charlotte is notable for the remarkably good macadam roads all the way. For a week prior to the tour a band of convicts was set to work on this stretch of road and when the cars passed it was generally remarked that the road compared favorably with the best in New Jersey as far as smoothness was concerned.

Charlotte is a manufacturing city, developed from an agricultural city. It has good water power and facilities for turning it into electric current. As a result the cotton mills of Charlotte are gigantic affairs turning out immense amounts of cloth and yarns. It is the undoubted cotton manufacturing center of the South. But Charlotte needs hotels. The experience of the Glidden Tour may have been unusual and extraordinary while stopping over night at Charlotte, but it can be said with conviction that nobody connected with the tour enjoyed the stay.

From Charlotte to the South Carolina line is 53.3 miles on the road used for the Glidden Tour, but after next Spring it will be shortened by 10 miles when the detour to cross the Catawba River, using the old iron bridge north of Charlotte, will be eliminated and the river will be crossed just east of Belmont, via a magnificent new concrete bridge that is now being constructed at the scene of Sloan's old ferry, a stumbling block of former years. The roads are fine clear to Bessemer City, being composed of good macadam and nicely improved sand-clay. This is 40 miles from Charlotte and all the way the cotton fields extend as far as the eye will reach.



Old wooden bridge a few miles out of Winston-Salem on the way to Kernersville

example of Davidson County, N. C., intelligence, without using the utmost care and skill.

This spot absolutely prohibits wagon traffic in wet weather, and the general impression seems to prevail that the reason for



The macadam road into Concord is as good as any to be found in New Jersey

# Franklin Omits Auxiliary Exhaust

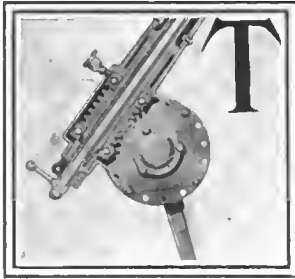

Fig. 1.—Steering detail

auxiliary exhaust valve which was located at the bottom of the stroke and through which about 70 per cent. of the exhaust products passed.

The five models which are embraced in the Franklin line include motors of 18, 25, 30 and 38 horsepower, having bores of 3 3/8, 4, 3 5/8 and 4 inches respectively. The stroke of all models is 4 inches and the number of cylinders is four in the case of the first two models mentioned and six in the other two. The details of construction for all four types of motors are similar and a general description of the Franklin motors will fit any of the types manufactured. Where any departure is made from the standard methods it will be mentioned in the following description.

The cylinders are cast separately to provide room for the vertical air flanges, to pass entirely around the cylinders. These ribs by means of which the motors are cooled, are integral parts of the cylinder castings and extend down to the bottom of the combustion space of the cylinder. The valve cages are also parts of the cylinder castings, as may be seen at C, Fig. 2. The cylinders are fastened to the crankcase by means of holding-down bolts B which pass through the flanges at the bottom of the casting and into the upper part of the crankcase. The bottom of these bolts may also be seen at B in Fig. 3. The material from which the cylinders are made is of selected gray iron. The vertical flanges, which are integral parts of the cylinders, are 8 inches in length, 1 inch in depth and 1/16 inch thick, they are set into the cylinder to a depth of 1/8 inch to secure a rigid connection, and are placed at intervals of 3/16 inch entirely

THE Franklin Automobile Company, of Syracuse, N. Y., which has just come forward with its latest developments, has not designated the new models by the year in which they are making their appearance, but has departed from this practice and has changed the nomenclature of the different models to a letter system. But few changes mark the introduction of the new cars, the chief of these being the omission of the

around the circumference of the cylinder. An outer covering of sheet metal is placed about the flanges as shown at O, Fig. 2, for the purpose of confining the cooling air to the flanges which form the heat radiating surface.

The cooling air is circulated through the air jacket in a very ingenious manner. A sheet-metal partition is constructed and so placed that it touches the dash, the sides of the hood and the air jackets at about the center of their length, thus dividing the space into two air chambers, one above this partition, which is covered by the motor hood, while the other is below the partition and is covered by the bottom pan of the motor. Between the two air chambers the only possible passage for the air is down through the vertical flanges of the cylinders. A suction fan is located in the flywheel, being formed by the vanes of the wheel. When the motor is in operation the revolving flywheel fan tends to form a vacuum in the lower air chamber, thus bringing currents of the air down from the upper air division which must pass through the cooling flanges to pass into the bottom chamber.

The supply of fresh air in the upper air chamber is unlimited, as it is drawn through a grilled opening in the front end of the engine hood, and since the partial vacuum which is produced in the lower compartment must be equal throughout the compartment, a like amount of air will pass through each cylinder air jacket and the cooling effect on each cylinder will be exactly the same.

## Lubrication Receives Special Attention

Owing to the fact that the Franklin motors are required to work at a higher temperature than water-cooled motors the oiling system has been given particular attention. The system used is known as the recirculating force-feed type. The oil is contained in an aluminum sub-base which is bolted to the crankcase and separated therefrom by means of a wire gauze screen partition. In the four-cylinder models the oil reservoir runs the entire length of the crankcase, while in the six-cylinder models the sub-base is beneath cylinders three, four, five and six. The lowest part is beneath the last cylinder, at which point are located an oil gauge, pump and a screw plug for draining purposes. The pump which takes the oil from the reservoir sends it through an individual lead to each main bearing. These leads are exposed

as may be seen at L, Fig. 2, in order that they may be readily inspected in case there is any difficulty with this part of the oil system. The oil which is forced through each of these individual leads passes into a groove in the upper half of the main bearing bushings. Another and smaller oil groove intersects the first groove and extends almost the full length of the bushings. A drill hole in the crankshaft communicates with the grooves in the main bearing bushings during out-half of each revolution, and the oil, which is under pressure from the pump, passes through this groove and is carried along into the crank cheeks. The centrifugal force due to the rapidly revolving crankshaft throws the oil into the leads in the connecting rod bushings, the lower halves of which are identical with the main bearings.

The oil which is thus carried to the connecting rod bearings is forced out of them

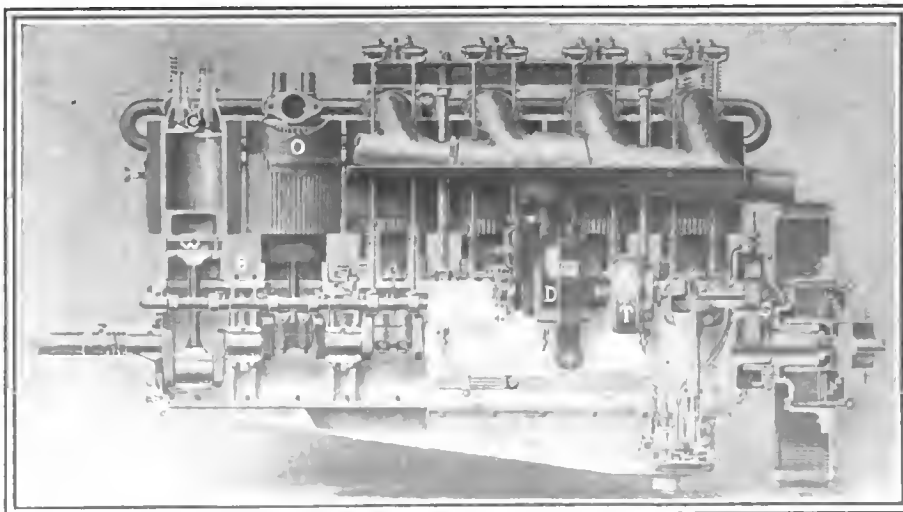

Fig. 2.—Longitudinal view and part section of Franklin air-cooled motor



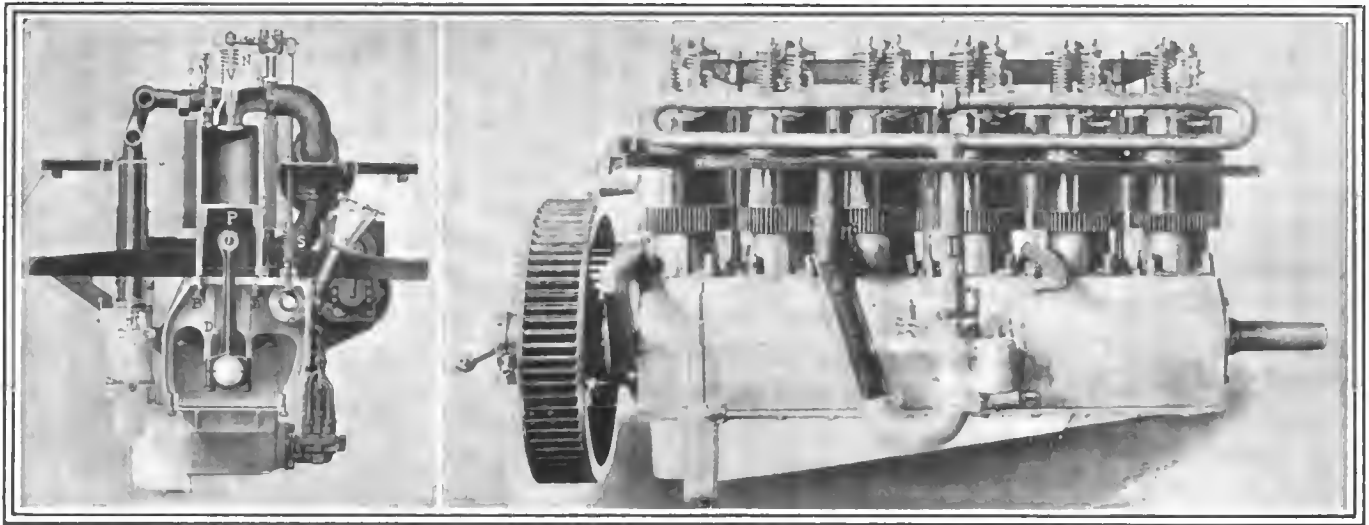

Fig. 3.—Showing transverse section through motor and a longitudinal view of the intake side.

and thrown off the end of the rod in a fine spray which pervades the engine base and lubricates all the moving parts of the motor, including crankshaft bearings, cylinders, pistons and the valve mechanism. The surplus oil drains from the cylinder walls and other interior parts of the motor, and falls down upon the base, where it passes through the mesh gauze and into the reservoir. The gauze strains out any sediment and metallic particles and keeps the oil which passes into the reservoir clean. There is an independent lead E which passes from the pump to a sight feed on the dash. The oil which passes through this sight feed drains back into the rear of the crankcase casting and down over the camshaft, spiral magneto gears and thence back through the wire gauze into the reservoir.

#### Some Details of Motor Construction

A departure from the lubricating system just described is employed on the Model G runabouts. They are equipped with a multiple force-feed system. Oil is pumped by means of a Hancock oiler to the main bearing.

The reservoir on the Model H and D motors has a capacity of 3 gallons, that on the M 2 1-2 gallons and the G 2 gallons. The Hancock oiler will hold about 7 pints.

The pistons, P, Fig. 3, on all the Franklin motors are fitted with three rings, all of them being above the wristpin. The rings are ground to size and balanced in connection with the pistons. As may be seen in the illustration, the pistons are of the flat-head type and taper in thickness to a point near their lower extremity, where a boss may be seen. A very thin aperture is seen between the wall of the piston and the cylinder in the sectional view. This is for the purpose of catching up the oil from the cylinder wall and distributing it over the upper part of the piston. The wristpin W, Fig. 2, is driven through the aperture in the interior of the piston, and is fixed in position by means of a set screw which passes through it. As the wristpin is hollow and open at either end, a quantity of oil will pass into it which will eventually work its way by means of a duct to the wristpin bearing bushing.

Owing to the method of casting the cylinders singly a main bearing is inserted between each, so that in the four-cylinder models there are five main bearings, and in the six-cylinder models there are seven. These bearings are supported upon bridges which are formed by webs in the crankcase casting. The construction of these bridges may be seen in Fig. 3 at D. The web also forms the basis of the camshaft bearings C and serves generally to stiffen the entire structure.

The valve action is operated by means of a single camshaft located upon the left side of the motor. The valves are separate in the head of the cylinder. The composition of the valves is silico-manganese steel, treated in the electric furnace. Both the intake and exhaust valves are the same size on the D and M

models; upon the G, however, the exhaust valve is 1 3-4 inches in diameter, while the intake valve is but 1 1-2 inches. On the model D motor the largest diameter of the exhaust valve head is 1 15-16 inches, with an overall length of 5 15-16 inches. The length of all the valves is 1-4 inch. They are all operated, as may be seen in Fig. 3, by camshaft, the cams of which operate directly upon the pushrod R through the spring S and thence through a walking beam W to the valve stem V. This arrangement is similar to the methods used in former Franklin practice, except that the camshaft is of one-piece construction, being turned down from bar stock, and the cams are integral parts of the shaft.

Valve timing and adjustment is made possible by means of a lock nut which is placed against the walking beam adjusting screw and which is so set that the relative positions of the valve may be changed with the different settings of the flywheel. The fulcrum of the rocker arms is formed by an I-beam support which runs along the top of the cylinders from one end of the motor to the other. The rocker arms touch upon the ends of the valve stems and are held in contact with them by a spiral lifter spring N, Fig. 3, at the base of the valve lifter rod. The rocker arm supports are attached by perpendicular rods to the engine base, so that any variation in valve action, due to the expansion of the cylinders when hot, is rendered impossible.

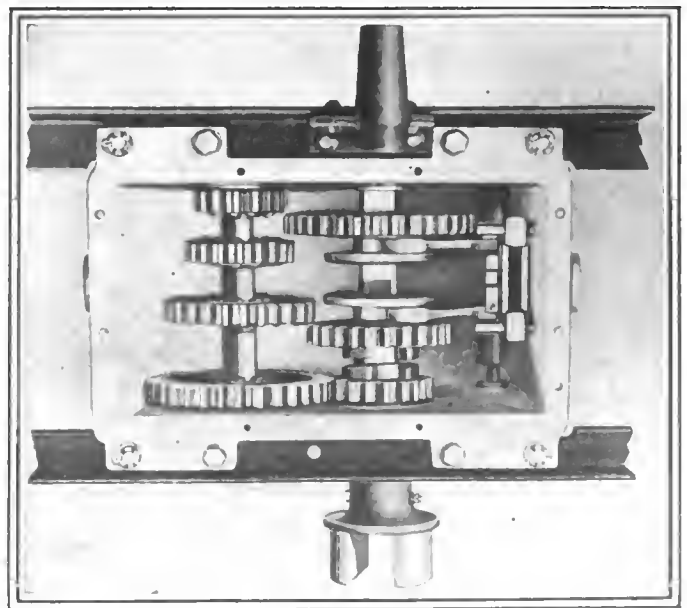

Fig. 4.—Looking down into the Franklin gearset housing with the cover removed





Fig. 5.—The Franklin fore-door roadster showing exterior position of speed-change lever

The carbureter is located on the right side of the motor. It is of the Franklin automatic float-feed type. In the six-cylinder models an auxiliary air intake valve is fitted, which is operated by the suction of the motor. A coil spring keeps the valve seated until the motor pulls more strongly when speeding up, at which time, the suction becoming greater than the strength of the springs, the valve opens and additional air is admitted to the intake manifold. The temperature of the vapor on its way to the combustion chamber may be regulated by a hot-air pipe which draws its supply from a sleeve fitted about the exhaust pipe. In cold weather all of the air taken into the carbureter may be drawn through this hot-air intake; similarly in hot weather the air from the mixture may be governed so that it will not be greater than atmospheric temperature. The carbureter needle valve which controls the supply of gasoline is regulated from the dash. As may be seen at I, Fig. 3, the mixture passes from the carbureter through a vertical pipe which leads into an endless elliptical intake manifold. The vertical pipe enters this manifold on one side while on the other the various leads to the cylinders are fixed. In passing into the cylinders the mixture must go at least half-way around the manifold, so that an equal quantity and quality of mixture is assured to each cylinder. The exhaust manifold M, Fig. 2, is fitted upon the opposite side

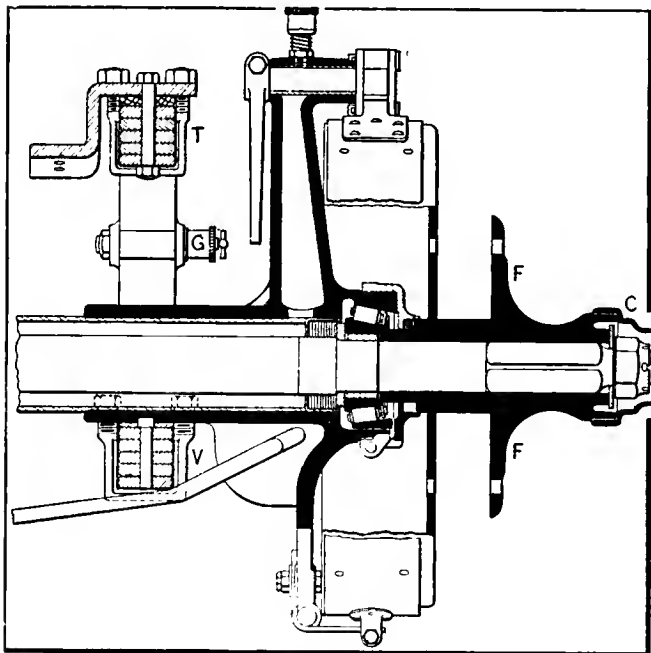

Fig. 6.—Section through wheel hub and axle showing brake and spring supports

of the cylinders from the intake, and is of large dimensioned injector type, sloping downward toward the rear of the motor.

Ignition is furnished by the Bosch dual system, a high-tension magneto providing the spark, while a storage battery, which is located in a battery box on the running board, supplies the battery ignition. In order to promote accessibility as far as possible, all the wiring is exposed where this can be done without danger. The magneto is shown at D, Fig. 2, and is driven by the train of spiral timing gears S through the camshaft which runs along this side of the crankcase. The speed of the magneto is regulated by a centrifugal governor operated by means of weights and springs within the drum T. The governor shaft has upon its end, within the drum, a gear meshing with two segments which are a part of two pivoted weights located on opposite sides of the drum. As the governor shaft revolves the two weights tend to be thrown by centrifugal force toward the perimeter of the drum. This tendency is resisted by the spiral springs, which are strong enough to hold the weights in their original position until a speed of about 300 revolutions per minute is reached. At that point, however, the automatic brakes by which the spiral springs are assisted give way and allow the weights to start and move outward toward the circumference of the drum. This motion of the weights will move the drum along the magneto shaft to which it is keyed. This advances the armature and sets the spark ahead, thus providing the proper spark for any engine speed. On the left side of the dash is placed a kick switch, which has in its center a button that may be used for starting on the batteries. On the larger models the ignition timing is controlled by the governor, while on the G runabout it is constant.

The clutch is of the Franklin multiple-disc type and is incased in the flywheel. It is operated by a pedal which works through a small round hole in the footboard. The clutch housing is an oil-tight casing and the clutch runs continually in oil. The facing of the clutch is bronze on the driven members and steel on the driving members.

The gearset is of the Franklin selective sliding type, having three forward speeds and one reverse. It is enclosed in an oil-tight casing which may be seen with the cover removed in Fig. 4. The gear wheels are of specially hardened steel designed for durability. A feature of interest in connection with the Franklin gearset is that the shift lever shaft runs across the top of the gearset casing instead of passing through it. This construction allows of a shifting of gears with a shorter movement of the hand. The gear ratio on the H and D models is 3.75 to 1; on models M and G, 3.71 to 1, and on the G runabout, 3.78 to 1. A threaded plug is fitted in the bottom of the aluminum casing, through which the oil may be drawn off when it becomes necessary to renew the supply. The shafting of the gearset runs upon ball bearings.

#### Transmitting Power to Road Wheels

The drive is taken up by the propeller shaft through a universal joint which is fitted just aft of the gearset casing. This shaft is of special heat-treated steel and is also fitted with a universal joint at the rear end. Power is transmitted by the shaft into the differential by means of a star pinion fitted to the end of the short differential shaft which runs upon ball bearings in forward end of the differential casing. In passing from the universal joint at the rear end of the propeller shaft into the differential casing this short shaft goes through a packing box which precludes the leakage of any oil from the differential through this joint. The packing box casing is held in position by the bolts D, shown in Fig. 7. The star pinion P engages with the bevel wheel D, which is fastened to the annular wheel W, which in turn drives the two spur wheels S. The latter wheels transmit the drive to the live rear axle A. The differential wheels and shafts throughout run upon ball bearings, indicated by T in the illustration. The ends of the axle shafts are squared so that they may easily be withdrawn by simply removing the hub cap C.

The live axles deliver their power to the wheels by means of a flange F, Fig. 6, which is bolted to them by six bolts. The

service brakes are of the contracting type, faced with Raybestos. They operate upon the change-gear shaft. The emergency brakes are also of the contracting type and operate upon bands located at the rear wheel hubs. The emergency brake bands are also faced with Raybestos. The service brakes are controlled by means of a pedal from the driver's seat, while the emergency brakes are controlled by a lever located on the right side of the driver's seat.

The wheels are of the wood artillery type, having twelve spokes both front and rear in all models. The hubs are castings, while the wood used in the construction of the wheels is of second-growth elm or hickory. All the wheels are of standard universal quick detachable type, designed to fit any make of tires. On the Model G touring car the tires to be used are 32 x 4 inches both front and rear. On all other models the rear tire equipment is larger than on the front. On the Models H and D the tire sizes are 36 x 4 1-2 inches and 37 x 5 inches; the Model M, 34 x 4 inches and 34 x 4 1-2 inches; on the G runabout they are 32 x 3 1-2 inches and 32 x 4 inches. The wheelbases are as follows: On the H, 126 inches; D, 123 inches; M, 116 inches, G, 103 inches, and the G runabout, 100 inches.

### Laminated Wood Chassis Still Retained

The Franklin company still maintains the wooden chassis which has characterized its line in the past. Laminated wooden sills are the direct support of all styles of body. The front axle is of the built-up type with the knuckle yokes and spring chairs hot riveted to a nickel-steel tube. The knuckle connecting rod is fitted in the rear of the axle tube. The axle is of drop construction. The side members of the frame are of wood built up in laminations, giving a rectangular section. There is no drop in the side frame. Maximum depth of the side members in the Model G runabout is 5 3-4 inches; in all other models a maximum depth of 6 1-2 inches. In all cases the width of the members is 1 3-4 inches.

Elliptic springs are also continued as a feature of this year's cars. On the Model G runabout the width of the spring plates is 1 1-2 inches and the span 36 inches in both front and rear. In the Model G touring cars the width of the plates is 1 3-4 inches, while the span of the springs is 36 inches. In the Models M, D and H the width of the plates both front and rear is 1 3-4 inches, while the span of the spring is in all cases 40 inches. In Fig. 6 the manner of attaching the springs to the chassis by means of U-clips is shown at T and V. Lubrication is provided by means of specially fitted grease cups G which are also shown in the illustration.

The steering gear is of worm-and-gear type actuated by a large steering wheel built up on an aluminum spider. The worm which turns the gear runs upon ball bearings which are adjustable for wear. A section through the steering gearcase is shown at Fig. 1. The throttle control lever is located upon a quadrant situated on the steering wheel spider. This lever actuates a shaft which passes down through the center of the steering column and terminates in a small bell crank lever to which the throttle governing rod is attached. Spark control is entirely automatic and therefore there is no ignition lever upon the steering wheel.

A special accessory fitted to all the new Franklin cars is a gas lock located on the right sill beneath the driver's seat, for the purpose of preventing the theft of the car. In connection with the gas lock valve there is a device for the purification of the gasoline on its way to the carbureter. It consists of a metallic cylindrical chamber located just within the sill and connecting the four-way gasoline valve of the gas lock. Within this cylinder there is a removable screen of fine wire gauze. The gasoline which enters the chamber comes up through the bottom by means of a small standpipe which projects into the chamber more than half-way to the top. The exit of the gasoline is near the top of the chamber and gasoline cannot flow out, therefore, until the compartment is nearly full. Hence, sediment or water will settle to the bottom of this trap and may be drawn out through a cock in the bottom. If it is desired to clean the screen the cover of this chamber may

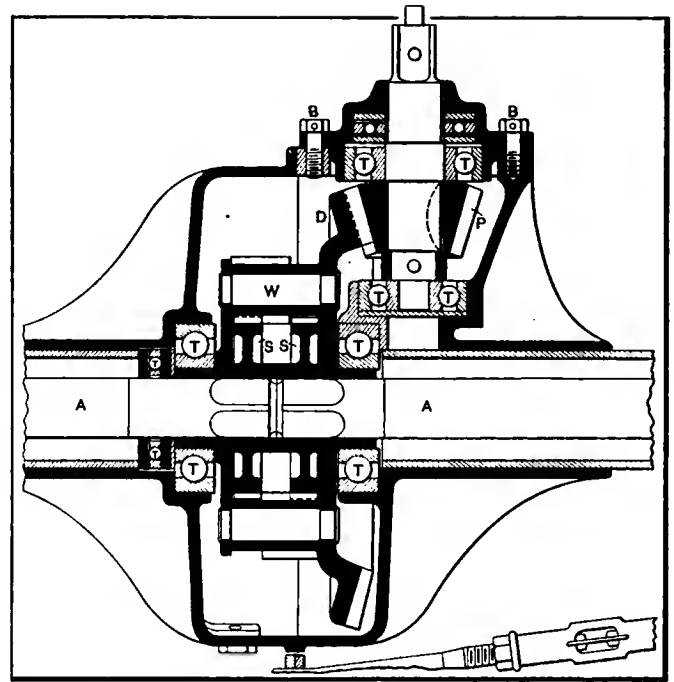

Fig. 7.—Showing the differential in sectional view. Note positions of ball bearing

be unscrewed and the screen removed. Among other refinements is a priming rod which projects through the mud apron at the front end of the car. By pulling out this rod the flow chamber of the carbureter is flooded with gasoline so that a rich mixture is procured in case it be necessary to assist in starting the car. Priming cocks are also fitted at the top of each cylinder above the intake valve, through which gasoline may be dropped into the cylinders should it be necessary. A foot accelerator and a muffler cut-out are also a part of the regular equipment, which includes a top, windshield, headlights, tools, storage battery and side and tail lights, the latter on the models H, D and M, being combination oil and electric. On the Model G touring and runabout side and tail lights are adapted for oil only.

Royal blue is the standard color for all touring models, with striping a tint of the same color. Trimmings are black, and black hand-buffed leather upholstery is used. Metal work is finished in black enamel and nickel. The D torpedo model is painted dark tan with tan trimmings, and is upholstered in dark russet, while the M torpedo phaeton is bronze green, with bronze leather seats and cushions. The sloping hood is continued and the fore-door is also a feature of Franklin 1912 construction.

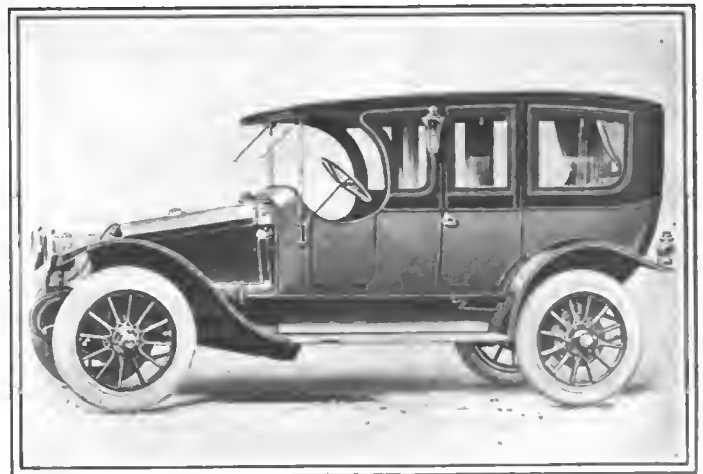

Fig. 8.—The Franklin seven-passenger limousine with full equipment throughout

# Tesla's New Mechanical Principle

## Wide Field for Efficiency Increase in Motor Practice

**A**N engine which uses gasoline as a fuel and is capable of delivering 60 per cent. of the inherent energy of this fuel at the crankshaft instead of the customary 18 to 22 per cent. has been invented and constructed by Nikola Tesla.

"It is well known," states the inventor, "that a fluid possesses, among others, two salient properties: adhesion and viscosity. Owing to these a body propelled through such a medium encounters a peculiar impediment known as lateral or skin resistance, which is two-fold, one arising from the shock of the fluid against the asperities of the solid substance, the other from internal forces opposing molecular separation. As an inevitable consequence a certain amount of the fluid is dragged along by the moving body; conversely, if the body be placed in a fluid in motion, for the same reasons, it is impelled in the direction of movement."

Based on these observations, Nikola Tesla, the discoverer of the polyphase alternating current, has developed a new mechanical principle broadly applicable for the generation, transformation and transmission of mechanical energy. The machines constructed by Mr. Tesla are illustrated herewith, partly by photographic reproductions and partly by sectional drawings which ac-

companied Mr. Tesla's original treatise in the *Electrical Review and Western Electrician*, September 9.

In the development of his machines it has been the aim of the inventor to let the energated fluid *flow along its natural paths*; that is, those of least resistance, with as small a friction loss as possible. It is important to keep in mind the fact that in his, like in all other mechanical devices, *friction is inevitably equivalent to a loss in efficiency*. With these points in view Mr. Tesla uses in his construction but a few simple and economic elements creating as little resistance as possible for the fluids moving his machine or moved by them.

The machine, Fig. 1, is of simple construction and may be used as a motor or as a pump. In a steel housing, very much like to that of a centrifugal pump, is contained a runner consisting of a number of steel or bronze plates arranged in series upon a shaft, Fig. 2. Each plate or disc has three central openings A extending from the shaft to about one-third of the radius and separated by spokes. These openings are cut or stamped out of the discs and the surfaces of the latter are kept as smooth as possible.

If the device, Fig. 2, is mounted on bearings and rotated at considerable speed the following phenomenon takes place. The air, in direct touch with the metal discs, is held to them by molecular adhesion, clinging to the metal surfaces as water does to that of a solid it is brought in contact with, and therefore the air particles next to the discs are imparted motion in the direction of the rotation of the discs. Thus, some air is dragged along and its particles begin revolving about the shaft of the device. Since the movement of the air is rotary, centrifugal force causes it to move away from the central portions of the discs, the resultant between the rotary and centrifugal force being along a spiral line. This flow of air toward the periphery of the discs causes a fall of atmospheric pressure at the central regions, and these being occupied by the openings, air rushes in through the openings, and thus a continuous flow of air is maintained.

If the discs are enclosed in the casing seen in Fig. 1, and the shaft is rotated, the unit will work as a pump. In order to explain the office of the inlet and outlet pipes seen in the illustration, Fig. 3, is offered to illustrate the Tesla pump in partial end view and vertical cross-section. The air adjacent to the discs is dragged along in the direction of the arrows, approaching at the same time the periphery of the discs. In addition to this the particles not in direct touch with the discs, but with the moving air, are dragged along and imparted motion through viscosity, that is, the attraction of the particles of a fluid. The viscosity of air is about 100 times that of water. Thus, the entire body of air between the two discs—unless they are spaced too far—is transported to the peripheral portions of the interdiscular space and, after having reached the periphery, streams along the wall of the casing, which widens from the point 1 to 2, 3 and 4, until the air reaches the outlet where it is discharged. The quantity of the fluid propelled through this pump, according to tests made by its inventor, is approximately proportionate to the active surface of the runner—the total active surfaces of all the discs on the shaft—and to the effective speed of the machines; therefore, the performance of the pump is bettered with increasing size and number of revolutions per minute.

The machine, Figs. 1 to 3, has twenty-five plates 9 3/4 inches in diameter, the entire runner being 2 inches thick and the full weight including the casing of the machine being 20 pounds.

If a fluid under pressure is permitted to enter the casing

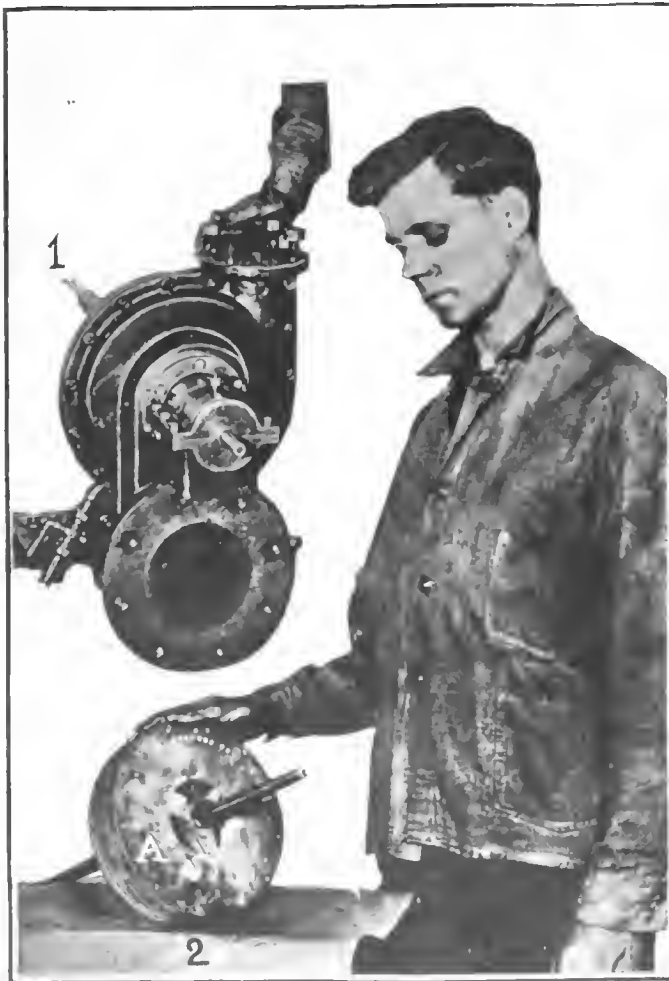

Fig. 1—110-horsepower steam-gasoline engine, weighing 20 pounds.  
Fig. 2—Shaft and runner of engine

through what is marked outlet, Fig. 3, it will flow along the wall of the casing, passing the points 4, 3, 2 and 1 in the order named until, when it reaches the narrowing near the outlet, which now is the inlet, it is forced to enter the interdiscular space. In doing this the adhesion of the discs to the fluid causes the former to have motion imparted to them, so that they begin to rotate, while the fluid, which is continually giving off energy, loses in velocity. Since bodies having rotary speed imparted to them are subject to a centrifugal effect, and bodies expending energy in creating rotary motion, to a centripetal one, the fluid with decreasing speed approaches the center of rotation, and is discharged dead, without pressure, through the central openings of the discs. It is exhausted by gravity through the opening marked inlet, Fig. 3.

The engine so described, when driven by a mixture of steam and the products of a gaseous fuel burned in an auxiliary chamber showed 110 horsepower on the brake, and more load could have been sustained by it except for the small dimensioned shaft. While this instance shows that the same machine may be used as a prime mover and as a pump, it is obvious that a machine of this type specially constructed for the purpose of driving machinery may be improved upon by adapting some details to the specific needs of the situation. Thus Fig. 4 shows a Tesla rotary engine, applicable for steam or hot-air drive, having a nozzle through which the pressure of the driving steam is increased. A reversing nozzle is also provided.

As in the other engine the runner is composed of discs D, having central openings O and spokes S. The discs are held in posi-

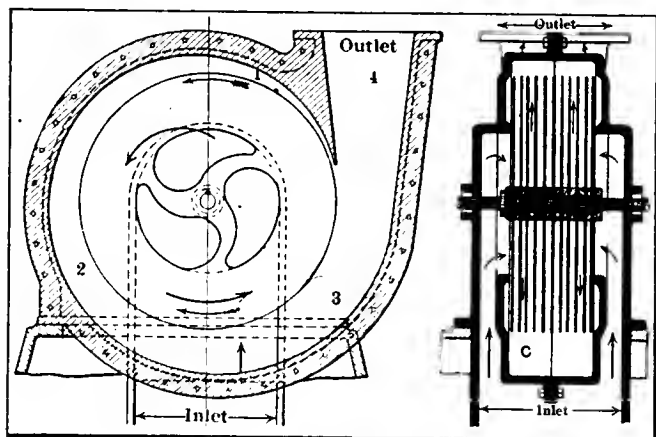

Fig. 3—Cross-section of Tesla rotary engine and pump

tion, being keyed to shaft S<sub>1</sub> which is mounted on suitable bearings. Washers W, conforming in shape to the spokes and riveted thereto, separate the discs. For simplicity's sake, only a small number of discs is shown, with proportionally larger intervening spaces than are used in practice. The runner is mounted in a casing having two end castings S with outlets E, stuffing boxes B and a central ring R<sub>1</sub> bored out to a circle of diameter slightly in increase of that of the discs. The ring has flanged extensions with inlets into which nozzles N are inserted. Circular grooves G and labyrinth packings P are provided on the sides of the runner.

A steam engine of this type has been installed and tested at the Waterside station of the New York Edison Company. The runner consists of twenty-five discs, diameter 18 inches, the engine base being 20 by 25 inches, and the height 5 feet. This engine developed, with steam admitted at 125 pounds pressure and exhausted at 14.7 pounds, 200 horsepower at 9,000 revolutions. About 38 pounds of saturated steam were needed per horsepower-hour, but Mr. Tesla stated that by the use of moderately superheated steam and the ordinary vacuum the consumption may be reduced to about one-third of the quantity stated.

If the motor runs without load, the fluid which enters at the periphery completes a number of circles before it has expended all its energy and it leaves through the central openings. As soon as the load is put on, the paths of the fluid are cut short, being

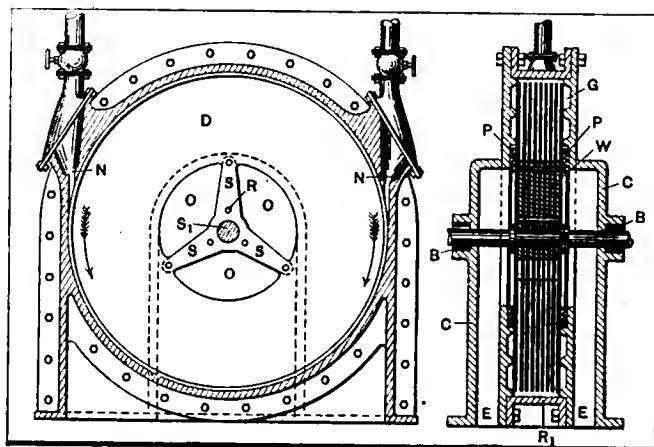

Fig. 4—Cross-section of Tesla engine for reversible steam drive

changed to a spiral with fewer turns. Despite the difficulty attending the work of determining the operating conditions in this machine, the following seems to be an established fact. The torque produced by the engine is directly proportional to the square of the velocity of the fluid relatively to the runner and to the effective area of the discs, and inversely to the distance between the individual discs. The maximum amount of work is done when the effective speed of the runner is one-half that of the entering fluid.

There is no unsurmountable difficulty in the construction of a light and practical motor of this type for the use of liquid hydrocarbon fuels. Of course, an auxiliary combustion chamber and carbureter have to be used in connection with the rotary engine described, and a very small pump to supply the air to the gasoline, if such be used. Mr. Tesla states that he has carried out numerous experiments along this line, and by the use of his motor transforms 60 per cent. of the energy of the gasoline into mechanical work available at the shaft. This may seem very high, but since with a rotary engine (compare steam engines and turbines) it is not necessary to encounter such vast cooling losses as in common gas engine practice, the high efficiency claimed by him might perhaps be obtained even in an average gasoline engine of his construction. It has been shown in THE AUTOMOBILE, July 27, 1911, pages 147-149, that the cooling losses in an automobile engine amount to 35.9 per cent., and the heat losses in the exhaust to 35.2 per cent. These heat losses together with other small expenditures of energies leave only 21.8 per cent. available at the motor shaft, that is, one-third of what is said to be recovered by an engine of the Tesla type.

The possibility of the enormous power output of Tesla engines in proportion to their weight may be understood when the great amount of active surface of these engines is considered. This fact also accounts to some extent for the large thermal efficiency. The 110-horsepower motor weighs 20 pounds, or 5.25 pounds per horsepower; the 200-horsepower engine at the Edison company's station weighs 400 pounds, or 2 pounds per horsepower, and by refinements of construction, the application of superheated steam and the use of vacuum exhaust Mr. Tesla expects to succeed in the building of an engine weighing 1-4 pound per horsepower.

A comparison between a Tesla pump and an ordinary pump may be of interest and not out of place here. In the laboratory of the inventor a small pump of the construction here illustrated is working. It is operated by a small electric motor, consuming 1-12 horsepower, and delivers 40 gallons per minute against a 9-foot head. The consumption of a good centrifugal pump rendering this work is about 1-3 horsepower, and in no case less than 1-4. This means one-third the power consumption for a given amount of work to be performed. As to the application of Mr. Tesla's principle to prime movers, it is stated by him that in large machines, by the use of superheated steam, high vacuum and the minimum of friction obtaining at these dimensions, about 95 per cent. of the fluid energy of the steam are delivered at the shaft.

# System Facilitates Car Repairs

Complete Set of Cards Necessary in Handling Repair Work from the Time the Car Enters the Shop Until It Leaves



**Peerless Motor Car Company**  
Test Report

Date Sept. 23, 1911

R. O. No. 4316  
Car No. 2795  
Owner Dr. Ad. Fisher

---

Engine overheats at high speed. Backfire at advance of 20°

Comm. Mag. Gov., Carburetor rich mixture

Clutch and Clutch Couplings and Foot Pedals O.K.

Transmission and Gear Shifting Levers noise on accel.

Steering Gear Fore and Aft Rods O.K.

Universal Joints and Prop. Shafts O.K.

Distance Rods, Torque Rods O.K.

Diff. and Pinions O.K.

Water Pump test for high speed

Others givoter and oil

Dash and all Wires O.K.

Spark Advance O.K.

Front Axle and Steering Joints trace of play at front

Emergency Brakes and Foot Brakes foot brake slips from wheel

All Wheels O.K.

Starting Crank O.K.

Signed Frank T. Brown  
Tester

Fig. 1.—Preliminary test report

**CHARGE ALL LABOR AND MATERIAL TO**

R. O. No. 4316

---

DETAIL OF LABOR TO BE PERFORMED

Look over engine for carbon, valves adjust carburetor. Look over & repair change speed act, spec. 2<sup>nd</sup> speed. Adjust oiler. Test water pump thoroughly & adjust. Look for radiator leaks. Eliminate play at steering gear. Adjust service brakes.

Repair hood & mudguards.

Repair upholstery on rear seat.

S. A. B.

Fig. 2.—Repair order sent to shop

GRANTING that speed of execution is a very desirable factor in shop operation, practice has demonstrated that only a thorough training of the workmen and systematic regulation of their operations will make the attainment of this end possible. Just as the half-dozen men serving a gun on a battleship must move rapidly and each man unfailingly fill his office, without ever colliding with his neighbor, so success in the operation of a large machine or repair shop is impossible without systematically directing the operation of every man engaged in a place of work. Moreover, the men must become accustomed to the system, so that after habit has become second nature with them, more and better results are obtained without increasing their efforts.

Division of labor is the key to efficiency and speed increase. According to this principle, an automobile turned over to the repair shop for complete repairs of the broken or damaged parts is submitted to a series of operations, each being performed by a man or men specially adapted for their work through experience along that specific line.

The manner in which repairs are handled by the Peerless Company, 1758 Broadway, New York City, is described. The system used has been worked out to minute details in many respects, but no trouble is being experienced in making the force utilize the system to advantage. The case here treated is that of Dr. Ad. Fisher's automobile, No. 2795, which he ordered to be put in good working order.

Although the owner specified some of the trouble which he noted on his car during its recent operation, the car after being turned over to the Peerless people was taken by the tester and given some 20 miles of road test. This developed all the symptoms written on the card, Fig. 1. The tester or his assistant made a note of all the suspicious points in the behavior of the car, and when machine and operator returned to the shop the test report, Fig. 1, was filled out. The troubles discovered in the engine, carburetor and gearbox were noted concisely, not forgetting the troubles of water pump and oiler. Dawson, the tester, after finishing and signing this report, handed it to the superintendent of the repair department to whom he turned over the automobile at the same time.

The superintendent then drew up the repair order, Fig. 2, No. 4316, and attached it to the steering wheel. The car was delivered to the machine shop, and before any of the real work was started upon it all the accessories were taken off and checked in by a boy, who placed them in a locker. This operation was described in detail in THE AUTOMOBILE, issue of November 23, page 914. Each accessory was provided with a small tag, Fig. 3, on which the repair order number, the number of the car and the owner's name appeared. Then the machine was turned over to the workers for overhauling. The men doing this work strictly adhered to the orders specified on card, Fig. 2, and checked by means of their service cards, one of which is shown in Fig. 4. This card is that of the man who took charge of the repair work after the engine had been cleaned and tuned up. The worker's name was entered on the upper left corner, and under Description of Work all the items were stated, which went to fill the time that he spent on the job. The order number of the repair which occupied him was the same, No. 4316, on all the items appearing on his card. To fix the time spent on each card, it was punched under Job Time. Two lines' space were given to each item of work, and on the upper line, marked A, the starting time was marked by means of a time punch, while the finishing time was noted on the next line under O. The interval between the two times was entered under Payroll Hours. If all the work were done during the regular working hours, the hours and minutes taken up by each job would have been entered under heading Regular Hours. It took J. H. Brown 1 hour and 8 minutes to adjust the carburetor, while the inspection and repair of the transmission took 3 hours 27 minutes. Time spent on testing and adjusting oil and water pumps amounted to 2 hours 42 minutes. Brown started the job when he came in in the morning, but Time came on before he had finished the radiator test, and since the car overhaul should be finished on that same day, he had to put in overtime on it, which amounted to 1 hour 50 minutes, 10 minutes being spent on the radiator and the rest as marked.



Having finished his share of work on the car, he turned the automobile and his own card over to the foreman of the machine shop, who then attached the card, Fig. 5, and sent it on to the paint shop. Work was done in the paint shop on the following day, and after the newly painted sections had dried, the automobile traveled to the trimming shop. Both in the paint and trim shop the workmen used a card identical to Fig. 4, and when they were through with their work the complete card, Fig. 5, was signed by their respective foreman and then turned over to the superintendent.

The office of the repair department is kept in a corner of the machine shop, and after everything ordered by the superintendent had been done, the car was returned to him after the accessories had been attached. At the same time the superintendent received a blue sheet adapted to fit into a binder. On this sheet the whole history of the car in the shop was entered, together with a record of labor and material used on it. The other cards were kept on file in the shop office. From the blue sheet the bill was drafted in the office, which was later on handed to the customer together with his car.

However, before the machine was delivered to its owner it was given a still more thorough road test than the one it received before entering the shop. The tester was not the same as in the preliminary test. If the same man had been on the job he would have kept a very sharp lookout for the troubles he formerly discovered, and if anything had not been repaired to his satisfaction he would have turned the car back to the shop. On the other hand, the man conducting the preliminary test might have overlooked some trouble or other which another man might have discovered in a final test. Dr. Fisher's car was found all right by the final tester, who signed his name to the card before delivering it to the superintendent. The superintendent put the final O. K. on the card, which stated that the automobile was in good shape and ready to be delivered to its owner.

This system, embracing quite a number of cards, is not complicated. Every man writes out but one card at most, passing it on to the next man, until everything comes back to a foreman or superintendent. By having everybody trained to the system, the Peerless company has succeeded in conducting its repair department on a very efficient basis and in satisfying its New York clientele, both as far as the speed and quality of the repair work done are concerned.

## Harking Back a Decade

FROM *The Motor Review*, November 28, 1901:  
At the race meeting held at Oakley track, Cincinnati, on Monday, R. Meyer won both events for gasoline cars. He defeated Max Fleischmann and Carl G. Fisher in one and Carl G. Fisher and H. W. Summer in the other. The best time he made in a 5-mile event was 8:32 3-4.

The following officers have been elected by the N. A. A. M.; S. T. Davis, Jr., president; E. P. Wells, secretary; Percy Owen, treasurer; A. L. Riker, first vice-president; C. J. Field, second vice-president; D. E. Rianhard, third vice-president.

Ralph Temple, of Chicago, has added the White Steamer and the United States Long Distance automobiles to his line, which already contains the Oldsmobile and National Electric. Temple's establishment is the largest in the city of Chicago.

C. B. Shanks is confident that he will succeed in driving a Winton automobile from the Atlantic to the Pacific next Summer, despite the obstacles that have stood in the way of such a feat. He will carry a letter from General Shafter to General Miles.

A station for the sale and care of Oldsmobiles exclusively has been opened at 138 West Thirty-eighth street, New York. The first shipment of forty cars is expected to reach New York next week. Its full allotment is 1,000 cars. R. M. Owen is in charge.

George N. Kendall, a retired manufacturer of Orange, Mass., has driven his Grout car for the past season, making 1,001 miles all told. Mr. Kendall says he never drives faster than 8 miles an hour and that the total cost of operation has been \$15, or 1 1-2 cents a mile. Mr. Kendall says that if others would use their cars as he does there would be fewer frightened horses and accidents.

Milwaukee, a city of 300,000 inhabitants, has only a single automobile store. This is the Oldsmobile branch.

Automobile exports for the week ending November 20, from New York, amounted to \$22,500.

Peoria, Ill., has passed an ordinance barring automobiles from the public parks of that municipality.

The projected race from Paris to Vienna now seems to be a certainty for next year. Objections to passing through Alsace-Lorraine have been made by some of the prospective French entrants and the route will likely be through Switzerland.

Fig. 5.—Every department chief signs this card after car leaves his hands

**Peerless Motor Car Company**  
New York  
Accessory Locker Dept.

Repair Order No. 4316

Car No. 2795

Car Owner Ad. Fisher

Fig. 3.—Tag attached to accessories removed from a car

DESCRIPTION OF WORK	ORDER NUMBER	DATE <i>Sept. 24-11</i>		JOB TIME
		PAYROLL HOURS		
<i>adjust carburetor</i>	4316	1:08		
<i>Inspect &amp; work on trans.</i>	4316	0:27		
<i>Oil &amp; water pump</i>	4316	2:42		
<i>Test radiator</i>	4316	0:53	0:10	
<i>Test, disassemble &amp; adjust steering gear and brakes</i>	4316		1:40	

Fig. 4.—Workman's card on which time spent on each job is noted

# Digest of the Leading Foreign Papers

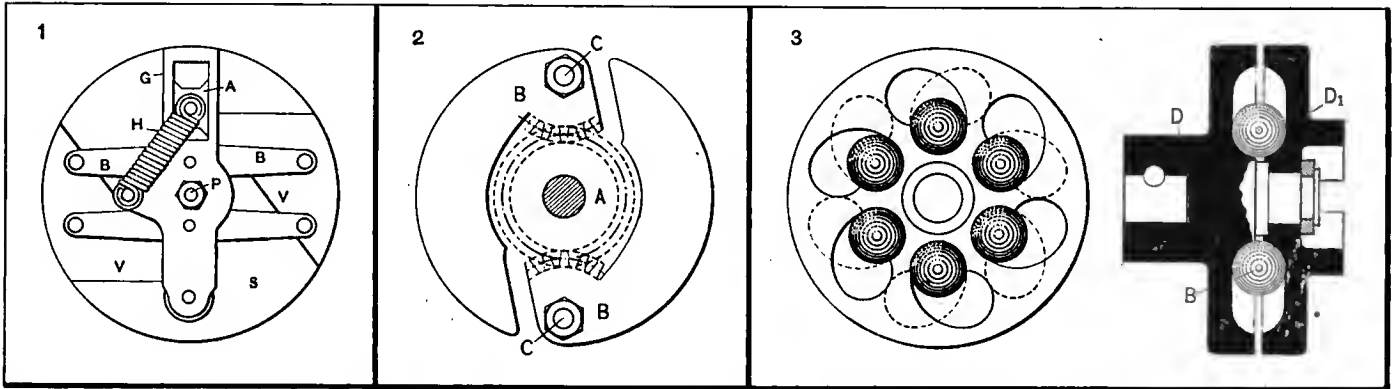

Fig. 1.—Timing the break of primary current  
 Fig. 2.—Turning armature by swinging weights  
 Fig. 3.—Curved sockets in multiple ball coupling of the Ruthardt Magneto

**E**NGINEER A. BERGER of Berlin gave a synopsis of the methods employed by vari-

## Automatic Magneto Timing

ous magneto makers to effect automatic advancement of the spark and thus dispense with the timing lever on the steering wheel. The observations refer to the ignition apparatuses exhibited at the recent automobile exhibition in Berlin.

The recent improvements in automatic spark timing may be ascribed to the strong competition among manufacturers of ignition devices and the necessity for appealing to the convenience of the automobile owner in the sale of their products. The centrifugality of rotary masses is the force employed by all to bring about a change in the timing. Unterberg and Helmle change only the time for breaking the primary current. The diametrical piece G, Fig. 1, which rotates with the armature shaft, carries the platinum contact P and is formed with a radial slide in which the centrifugal mass A works against the resistance of the helical spring H. The leaf spring B pulls the back of the mass toward the stationary plate S. If the mass passes the cut-outs V in this plate, the platinum points come for a moment in contact under the influence of the leaf spring B. But the edges of the cutouts, which determine the interruption of the primary current, do not extend radially but at a suitable angle, and ignition therefore takes place so much earlier, the farther the centrifugal mass is removed from the center of the device.

In all other magnetos it is the position of the armature, with interrupter, in relation to the drive shaft of the magneto, which is adjusted. In the Bosch and Eisemann apparatuses the required

movement is, as well known, effected by relatively large centrifugal weights causing a sleeve to slide outward on a high-pitch thread, offering an increasing resistance in the direction of rotation.

In the Mea apparatus a small spurwheel A, Fig. 2, upon the drive-shaft meshes with teeth D on the centrifugal weight BB, so that the latter when swinging around spindles C advance the armature shaft with which they rotate. The irregular back pressures arising from the inequalities in the armature drag are not in this case, as in the other constructions referred to, counteracted by any special provision for automatic brake action, but are absorbed in the inertia of the masses. On the other hand, it may be mentioned as an advantage that the resistance of the armature at starting of the motor assists the retaining springs for the centrifugal masses in producing a late spark.

The Ruthardt construction, Fig. 3, is notable for being applicable to any magneto, being placed in the market as a separate coupling between the drive-shaft and the armature shaft. A disk D fixed upon the armature shaft which is swiveled in the drive-shaft is driven by means of a disk D<sup>1</sup> similarly secured to the latter, the driving connection consisting of six steel balls B placed in curved grooves formed in the disks. These grooves are of opposite curvature, when the device is assembled, as indicated by the dotted lines. The driving resistance tends to wedge the balls into the position nearest the center, and centrifugal action, in pressing them outwardly, advances the relative position of the driven disk so as to make room for the balls

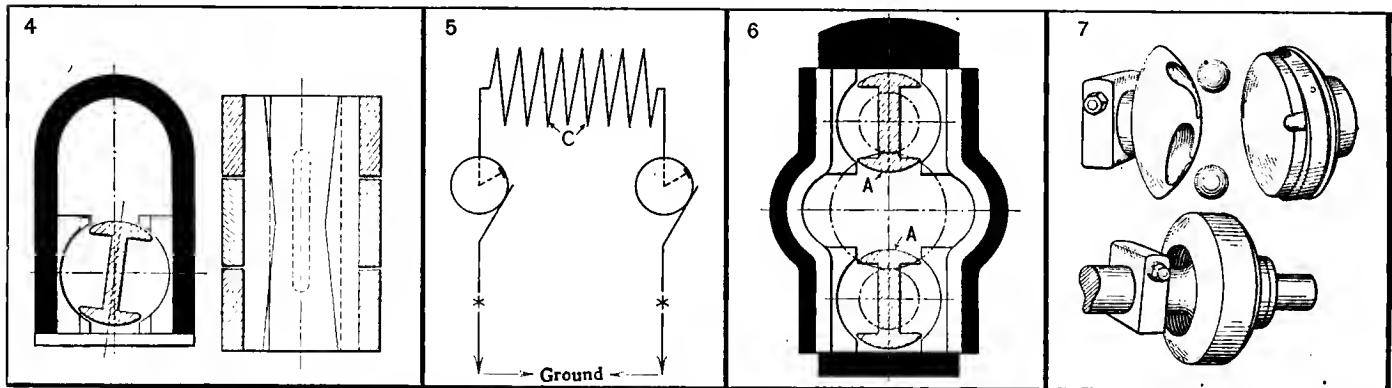

Fig. 4.—Larger ignition angle by re-designed pole pieces  
 Fig. 5.—Wiring for duplicate spark  
 Fig. 6.—Two magnetos on one base  
 Fig. 7.—Variation of multiple ball coupling

farther out in the grooves. The coupling may be either horizontal or vertical, as in a vertical position of the discs the tendency of the lower balls to take a more circumferential position by reason of their own weight will be counteracted by that of the upper balls to seek the center except perhaps at the start.

A very similar device, but in which one disc is convex and the other hollow, was brought out at the Olympia show in connection with the Simms magneto. This is illustrated in Fig. 7, the upper part showing the coupling in assembly.

Timing by changing the relations between motor and armature shafts has the advantage that the position of the armature giving the highest potential is always utilized, no matter how much the spark is advanced. And this advantage applies also when it is the magnet which is turned with relation to the armature shaft for the same purpose, as in the Mea device whose horizontal bell-shaped magnet is particularly adapted for applying the principle in this form, though it is done by hand from the steering wheel. And in this apparatus the designer has also succeeded in developing the polar masses so that the lines of force produce a maximum in the induced current for such a large arc of the armature circle that an early and a late spark are of almost equal intensity.

Eisemann exhibited magnetos with pole pieces whose contours in the longitudinal extension of the apparatus do not show a straight but a broken line, Fig. 4, and has reached usable angles of displacement up to 150 degrees. The same is said to have been accomplished by Bosch. It is at all events notable that strong sparks are produced at relatively very slow motor speeds at any position of the timing lever, and also that the well-known intermittent resistance of the armature is much less pronounced than in earlier types of magnetos.

Two innovations of more recent origin vie with one another: the two-spark and the twin-spark or dual-ignition devices. The two-spark magneto is applicable especially where it is of importance to effect a rapid combustion of the mixture in a broad combustion chamber, such as T-head cylinders. Unlike the twin-sparker it effects the ignition at exactly the same moment at the two plugs. The principle, as shown in the Bosch and the Mea exhibits, rests on placing the two plugs of a cylinder in series. As the two plugs have only one insulated pole both ends of the induction current are insulated and are led to separate distributors, or to one combination commutator. Fig. 5 shows a diagram of the current distribution. Short-circuiting in one plug from fouling or faulty insulation causes only a stronger spark in the other plug. A switch permits the driver to close one of the circuits and continue working with the other. While a plug failure with this system cannot break down the ignition, a defect in the magneto will on the other hand incapacitate both plugs and with this in view Eisemann and Fein built twin-spark or dual-ignition devices.

Eisemann simply mounts two normal magnetos on one base and drives the two armature shafts, each carrying a spurwheel, from a third spurwheel in mesh with both of them and places the spark-timing device on the shaft of the latter. The Fein construction, on the other hand, represents a combination of two devices in one, Fig. 6. Two armatures A, two commutators and two interrupters form independent sets both served, however, from the same magnetos. The spurwheel whose spindle carries both commutators on opposite sides of the machine, serves to couple the armatures, so that only one more spurwheel is required than in an ordinary single-acting induction machine. An advantage over the Eisemann construction lies in the fact that the base provided for a simple magneto suffices also and as well for the dual device.

The dual devices are useful for other purposes than double ignition. By displacing one of the two armatures 90 degrees there is obtained an ignition apparatus for an eight-cylinder motor and one operating with only one-half the number of revolutions required for an ordinary eight-cylinder magneto. Similarly the construction may be applied to V-motors and fan-spread motors without inadvisable increase of the speed, and the

failure of an interrupter in that case puts only one-half of the number of cylinders out of commission. Finally, a combination of single-spark ignition and a direct-current dynamo is possible with this type of apparatus, and the dynamo can be used for charging storage batteries for lighting and other purposes.

Battery ignition is, of course, not contemplated by the manufacturers of magnetos, except for double ignition with utilization of the same plugs and the same high-tension commutators for both ignition methods. By incorporating in the magneto a special wipe-spark device for the battery ignition, the two sparking systems can be rendered independent, in case one of the interrupters should fail.

The coil on the dash, which ordinarily works without vibrator, is in the Bosch construction provided with a vibrator which can be switched in by means of a push button for the purpose of starting the motor from the battery current. Eisemann has for the same purpose a current-breaking ratchet device turned by a small crank.

A starting arrangement enabling the driver to utilize the magneto coil to generate the starting spark was exhibited by Unterberg & Helmle in operation on a car, but the author was unable to examine it closely. Apparently the plan is to accelerate the armature suddenly by means of a lever mounted on the dash, and in addition there is a little steel bottle screwed into the combustion chamber of each cylinder. This is filled with combustible mixture from a compression stroke while the motor is working, and the mixture is released by the same crank lever movement which accelerates the armature, so as to turn the motor over even if no good mixture is otherwise at hand in the cylinders.—*From Der Motorwagen*, October 31.

### Market Conditions in Italy

Of the three large Italian automobile factories, the Fiat, the Itala and the Isotta-Fraschini, the two first named send the larger portion of their production abroad, mostly to other Romanic people, and the large number of Renault and English Daimler cars seen in the streets of Milan and other large cities shows that the strong national feeling among the Italians still leaves room for imports from foreign countries in the large and expensive types of cars. The Spa, the Scat, the Lancia and the Nazarro factories, where smaller cars are produced on a limited scale, are not yet in a position to build "in series" and pay duty on many construction parts imported from Germany. It should be possible to import a great many small cars, as such a sales-field as that of the physicians is uncultivated.

There is no dealers' class, in the ordinary sense of the word, in Italy, with very few exceptions. In Milan and Turin the purchaser goes direct to the factory, and a few customers doubtless make trips to these cities for the purpose of purchasing, but ordinarily the Italian will not go to this trouble. He goes to the garage owner and orders a car as he would a suit of clothes from a tailor. The garage man has a number of different makes on hand and catalogs of many others. An importer would probably find it needful to establish salesrooms with stock in Milan and Rome and to build up a sales organization from these centers.

Cabs and specially built public motor vehicles are not numerous in Italy, and the livery work is done mostly with old second-hand private cars, which are expensive to run and inelegant in appearance. And yet the populace of northern Italy loves dearly to ride in a real motor-cab and greatly appreciates elegance in lines and colors of the carriage body.

Italians are perhaps a little less patient about repairs than other nationalities, and stocks of repair parts are a necessity for holding and expanding any trade established in an imported model. They like to do all their dealing with one firm, and an importer will therefore find it of advantage to handle a suitable variety of tires and accessories, possibly in connection with a garage of his own—*Allgemeine Automobil Zeitung*, October 27.

# Letters Answered and Discussed

## Trouble with Valve Action

Editor THE AUTOMOBILE:

[2,927]—In making repairs on a car having a valve action as represented in Figs. 1 and 2 where F is the fibre insert; S, set screw; B, bushing; and camshaft C I am at loss to account for the excessive amount of noise emanating from this mechanism. The car has run but a few hundred miles, and though the motor was very quiet when new, it is now decidedly noisy. I am sure the seat of trouble is in the valve action, as a cushion inserted between the valve stem and the tappets stills the clatter.

The only wear I have been able to find

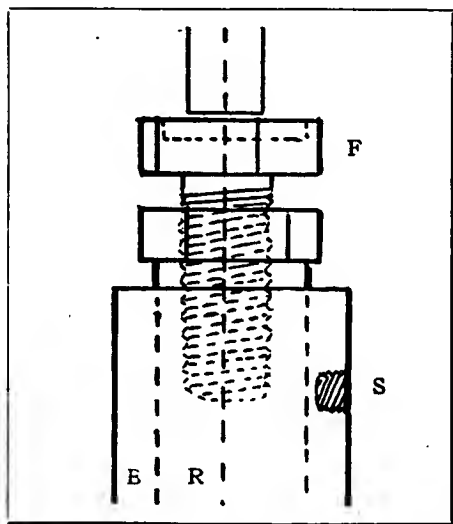

Fig. 1—Upper part of valve pushrod showing manner of adjustment

is as shown in the sketch—on lower end of the pushrod, where it bears on the cam. All of the right pushrods show this wear, which is barely more than 1-16 inch wide.

Would wear in this position, and of this dimension, cause the noise that is present? If so a remedy is obvious in regrinding and again casehardening the end of the push rod R, but as this would be no more permanent than originally I have considered the advisability of substituting a mushroom pushrod without changing the contour of the cams.

I realize this would greatly change the movement of the valve in relation to the position of the piston, causing a quicker opening after leaving the seat and holding the valve in the full open position for a longer interval.

I can see nothing detrimental to the function of parts by incorporating this change and I anticipate a benefit in eliminating much of the side-thrust on the pushrod and obviating wear on the lower end

*The Editor invites subscribers to communicate their automobile troubles and personal experiences, stating them clearly on one side of the paper. If the nature of the case permits, send a sketch, even if it be rough, in order to assist to a clearer understanding. Each communication will receive attention in the order of its receipt, if the writer's signature and address accompany it as an evidence of good faith. If the writer objects to the publication of his name, he may add a nom de plume.*

by spreading the wear out over a larger surface. Please tell me if this would be deleterious in the handling of the gases, and if impractical, why.

Does the pushrod bear on the cam during the closing of valve, or does the cam move faster than the spring returns the valve to its seat, when motor is turning above 1,500 R.P.M.

SUBSCRIBER.

Northampton, Mass.

The noise you complain of is caused, no doubt, by the wear on the bottom of the pushrods. By screwing upon the adjustment nut located on the tappet rod, the lost motion due to wear will be compensated for, and the noise will cease. It would not be necessary to make the complicated repairs you suggest. The spring action is faster than the camshaft action, hence the pushrod bears on the cam.

## Description of Rotary Engine

Editor THE AUTOMOBILE:

[2,928]—The rotary engine recently completed by Mr. Nikola Tesla weighing but 1 pound to the horsepower and being reversible seems to be likely to bring about enormous innovations in automobile practice, so far as motor construction is concerned, so that I hope you will look into the matter and publish such information as you think of interest.

CORTLANDT DE P. FIELD.

Peekskill, N. Y.

The description desired may be found on other pages of this issue.

## Wants to Know About New Motor

Editor THE AUTOMOBILE:

[2,929]—Do you know anything about the Tesla engine which has been heard of not a little of late? Is there anything in it, or is it only a pipe-dream?

If the engine is an accomplished fact, can you not and will you not give us a full description of it in THE AUTOMOBILE at an early date? Also your ideas as to its possibilities and probabilities of application to the automobile.

E. ATWELL.

Mountain Dale, N. Y.

On pages 950 to 951 of this issue a detailed description of the Tesla motor is given. We would call attention to the fact that the data contained in that report are the digest of actual experience.

## Avoiding Freezing

Editor THE AUTOMOBILE:

[2,930]—This is the season when anti-freezing solutions are in the mind of most operators of automobiles in the North. A great deal can be said for and against many of the preparations now on the market, judging from the literature circulated by the various manufacturing concerns. Will you kindly tell your readers through your answers to inquiries what you consider is the best preparation either on the market in commercial form, or which can be compounded by the autoist himself. The question may have been answered before

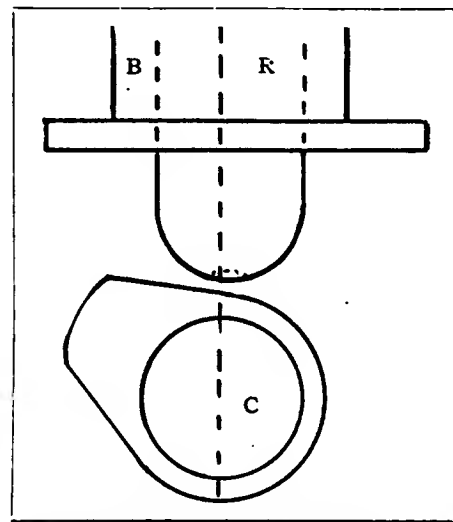

Fig. 2—Lower part of pushrod and cam. Dotted line shows wear on end of rod

but I am sure a repetition will interest a great many others.

H. D. MARTIN.

New York City.

The following is recommended by the Thomas company and expresses the ideas generally held at the present date:

A mixture of 25 per cent. of denatured alcohol, which costs the same as wood alcohol but is superior to it for the purposes required, will prevent freezing at almost any temperature we may have here. The drawback to this is the evaporation of the alcohol, and as the boiling point of the alcohol is much lower than water there is a liability of the motor overheating if the weather gets warm.

We have also used a solution of 15 to

20 per cent glycerine with good results, which will prevent freezing to 5 degrees below zero, and has the advantage of not evaporating, but it is open to the objection that on account of the presence of stearic acid in the commercial forms of glycerine it has an injurious effect of decaying rubber hose connections very rapidly, and occasionally bothers the driver by clogging the strainer of the water-pump.

We suggest that the radiator be protected by a leather shield covering one-third of the lower radiator surface, which makes the motor work very much better in cold weather, and also protects the carburetor, keeping the cold blasts of air from passing through the radiator. An excellent protection will be an asbestos board as this is a non-conductor of heat as well as cold. Either the leather or asbestos may be fastened with copper wire.

The method most in vogue with chauffeurs is to throw a robe over the front. Many use chloride of calcium or other solutions where it is necessary to depend upon a dissolving of chemicals, but there is a serious drawback in doing this, owing to the fact that the evaporation of water causes the chemical to precipitate, and in time forms a crust or coating in the water jacket of the cylinders, thereby reducing the cooling efficiency of the cylinders.

If it is ever necessary to have the non-freezing solution which you use during the Winter months drawn out of the radi-

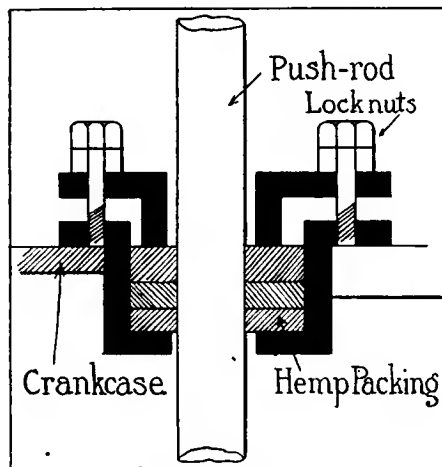

Fig. 3.—Valve rod stuffing box to prevent leakage of oil from crankcase.

ator, do not forget to personally see that it is replaced, for in many instances we have known of the solution being discarded through an oversight and water put back in its place.

### Oil Leaks from Crankcase

Editor THE AUTOMOBILE:

[2,931]—Being a subscriber to THE AUTOMOBILE I take the liberty of asking if there is any simple method of preventing the leakage of oil about the valvelifter cages, as these cages become worn a short time after renewing. D. T. DUKE.

Wellsville, N. Y.

The only method which can be used with success is the installation of a stuffing-box. This will have to be done by a regular repairman as it will be necessary to drill and tap the crankcase in order to take any of the standard types. A good form of stuffing-box is shown by Fig. 3.

### Truck Statistics

Editor THE AUTOMOBILE:

[2,932]—I wish to ask your opinion as to the probable number of commercial vehicles of all kinds in use at present in the United States. Also, your opinion as to the probable total number of commercial vehicles being produced yearly at the present time. L. B. GAYLOR.

Stamford, Conn.

As near as can be judged, there are over 10,000 motor-trucks operated in this country at the present time. According to the latest available census figures, the increase since 1909 in the number of these vehicles is about 7,000, there being 3,288 in use in that year. It is estimated that in the next 12 months there will be nearly 18,000 commercial cars manufactured.

### Rust in Radiators

Editor THE AUTOMOBILE:

[2,933]—When putting my car up for the Winter and letting the water out of the radiator I notice that rust comes out with the water. I have wondered if it would not be all right to put in a quart or more of kerosene or other oil and stop if possible any further rusting. I would let the oil either remain in the radiator or drain it out after a time, or else I could put in a little wood alcohol or other non-freezing solution. I would very much like to have your opinion on this matter.

G. W. WILLARD.

Dundee, N. Y.

Probably the best method would be to fill the radiator with a good non-freezing solution, as rust action is very slow when air is not in direct contact with the metal. A 50 per cent. solution of denatured alcohol and water will freeze at 35 degrees below zero and is very safe in most climates. Another good plan would be to run kerosene through the radiator two or three times. This should be done about once a month.

### Wants Soldering Information

Editor THE AUTOMOBILE:

[2,934]—I am a constant reader of your publication, but I cannot remember seeing anything in your columns on the art of soldering. There seems to be a dearth of information on this subject and yet it is of great use to a man who takes care of his own car. The greatest trouble with most amateurs I find is the inability to keep the copper in good condition.

I have used sal ammoniac dissolved in water and have also rubbed the copper on

a block of the same, but find that it eats the tin away. Is it not possible to get a high grade of copper which will hold the tin on the point without having frequently to re-tin it? Perhaps the quality of the sal ammoniac has something to do with it. I would be very pleased to have any information on the subject available. E. G.

Detroit, Mich.

With copper it would be better to use zinc chloride as a flux. If the copper is heated to redness at any time the tin will volatilize and retinning will be necessary. After dipping the copper into the chloride, the stick of tin is held against the surface and will be found to adhere until it is heated to the temperature of volatilization.

### Effect of Alcohol on Carbon

Editor THE AUTOMOBILE:

[2,935]—Would you kindly tell me through the pages of THE AUTOMOBILE what effect denatured alcohol would have on

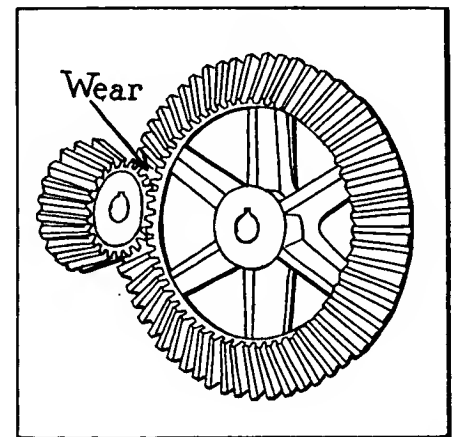

Fig. 4.—Showing the point at which wear and noise occur in the gears

the carbon in the cylinders if injected while the cylinders were hot? GEO. W. PORTLAND, Me.

It would have absolutely no effect whatever.

### Slashing Transmission Gears

Editor THE AUTOMOBILE:

[2,936]—I have a five-passenger touring car of a prominent 1912 make, and find it very nice all around, except that when I change speeds I hear a strange noise in the gearbox. I believe it is lost motion. What can I do to quiet the noisy member? Rockland, Me.

R. H. WATERS.

While it is true, in a way, that all noise is caused by lost motion, the noise experienced by you is not classed in general under that heading. The teeth of one gear strike those of another which it is to engage. Despite the high-grade material used in transmission-gears this practice is very harmful, and in time will spoil a good set of gears. It is either evidence of poor design in a car, or of lack of skill on the part of the driver. Fig. 4 shows the point at which the wear occurs, and it is this wear which causes the noise in the gearbox.



# Little Bits of Motor Wisdom

## Tools and Other Devices Useful to Repairman and Driver

**TROUBLES WITH BOLTS AND NUTS**—Care should be taken in starting a nut that it does not get cross-threaded, as shown (exaggerated) at A, Fig. 1. This more often happens when the thread is fine. In any case it often means the replacement of either the nut or bolt, or both, and there is no need for its occurring at all, if the nut is not forced when it is a little bit askew. Often when the nut cannot be made to start on the thread as it should the trouble is due to the burring of the first thread, as at B. This burring usually results from striking the end of the bolt with a hammer. When-

to get at some hidden part at the lower end of the steering column, or at some other equally inaccessible point they will soon appreciate the need of such a tool.

**RUST IS AN ENEMY OF TIRES.**—Rust eats into rubber tires like lye. It is usually formed on the rims and then gets onto the envelopes of the tires near the beads. In time this rust will eat through the rubber and attack the canvas as well. It is best to remove the tires from the rims when this discoloration is noticed. Get the rust off the tires first, then take some heavy

that it is worthy of more than a mere passing notice. The alligator-wrench which is illustrated in Fig. 2 consists of two fixed jaws which are serrated in the form of teeth and from which the wrench takes its name. It is more or less of a rough-and-ready tool inasmuch as when it becomes necessary to hit the work a few gentle taps it can readily be done with this wrench without grave danger that the tool will be greatly injured, as is the case with the more delicate monkey-wrench.

Many a good and useful wrench has been ruined through its misguided use as a hammer or mallet, and yet there are cases where it is not convenient to drop everything and secure a hammer when it seems that a couple of blows with the back of the wrench would readily do the work without further trouble. The alligator-wrench will fit any hexagonal nut sufficiently well to turn it to a reasonable degree of tightness. However, it must be remembered that this tool can be abused just the same as any other.

The chief objection to the alligator-wrench is that it is very apt to claw the corners off the nuts if it is used excessively. This is particularly true if great stress is put upon it, as in the case of tightening the nut, beyond the point where it will turn readily. That this should be true is readily apparent as it is a parallel case to using a wrench which is not an exact fit. In this case, if sufficient pressure is applied against the resistance to turning of the nut the corners will be stripped so that the hexagonal nut tends to take a round shape.

There are numerous instances where a wrench cannot be carried for every different-sized nut, and in this case the alligator-wrench is indispensable, for, owing to the long range in sizes of nuts which can be readily manipulated, provided they are not required to be tightened to too great an extent, there will rarely be a case which cannot be met with this form of wrench. In case the nut which has to be removed is rather tight, it is a very simple affair to strike it a few slanting blows with the wrench which will generally serve to

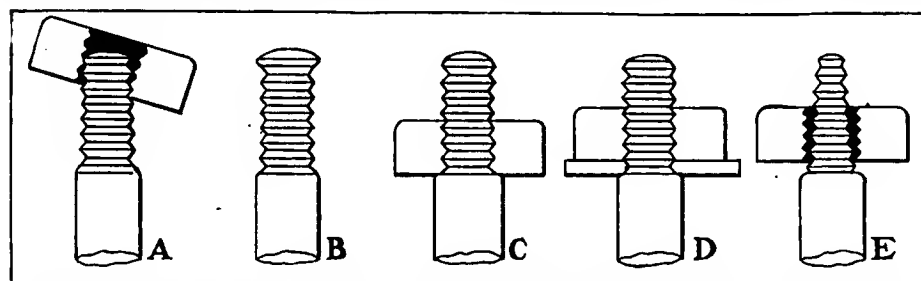

Fig. 1.—Illustrating the different ways in which threads are abused; also, defective thread

ever the use of the latter is necessary, a block of wood should be placed between it and the bolt head. When the end of a bolt is found to be burred in this manner, the trouble can be remedied by using a small file to rethread the damaged portion, first filing off the burr. Perhaps one of the worst mishaps is to twist off a bolt at some important point. This often results from trying to force the nut beyond the end of the thread when it is already against the shoulder, as at C. Sometimes the nut will split instead, if it is the weaker number, this being, of course, the lesser of the two evils. To prevent either from happening, place a washer or two over the bolt before putting on the nut, as shown at D. This is merely another ounce of prevention. When the thread is found to be poorly made in some such manner as is shown at E, the best thing to do is to run a thread-cutting die of the proper size, that is, having the same number of threads per inch as the bolt has, over the imperfect thread in order to reduce it in diameter near the shoulder. If the nut fits the smaller end, it will jam when screwed up farther, and will eventually either split or twist off. When the nut to be adjusted is rather inaccessible, there is no tool in the kit more handy than the socket-wrench, although some drivers do not include one in their equipment at all. Once they have

emery cloth and clean off the rim with it as well as possible. Next use some finer emery cloth and rub the rim until it is thoroughly free from the deposit and is smooth. If the rim is quite rough and uneven, first take a file and smooth it down before applying the coarse emery paper. After making the rim perfectly smooth re-japan it with one or two coats, and after this dries, rub it down again with the emery paper. This should entirely eliminate the rust, and make a smooth rim for the bead to fasten on, thus also doing away with the danger of tearing the latter every time the tire is removed. Another preventive of rust is flake graphite. To apply this to the rims, put on them a coat of shellac to which has been added enough graphite to form a thin paste. Graphite may also be used in the place of chalk or soapstone between the inner tube and the shoe. It is less injurious to the rubber, is more lasting, makes a good fit of the inner tube and reduces the heating. This, of course, refers to flake graphite.

**THE ALLIGATOR WRENCH**—It is often said that there is nothing new under the sun and this can certainly apply very readily to the tool known as the alligator-wrench. This useful article, while not exactly new, fills such a variety of purposes

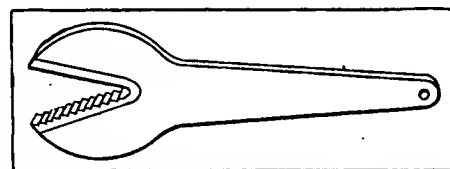

Fig. 2.—Showing an alligator-wrench which is often of use

loosen it to such an extent that the wrench may be applied for the complete removal of the fitting.

In case the nut which is to be removed will not loosen readily a method which is often successful is to apply the flame from a gasoline torch to the nut and then to gently tap the nut on one of the corners, being careful to apply the torch so that the flame is just on the nut. If no torch is available a little waste dipped in gasoline, wound about the nut and then lighted will do the work.

**OIL CANS TO BE CARRIED**—The railroad engine driver with his rack of oil cans does not find a parallel in the driver of the modern automobile, so far as these instruments of lubrication are concerned, because the problem of accessibility is not only much more simple in the automobile but also because the problem has of late been given the attention it deserves and inaccessible spots are rapidly vanishing. The spectacle afforded in past years, of seeing the operator of a gaily painted automobile lying flat on his back in the middle of the road vainly tinkering with the mysterious and hidden secrets of the mechanism has all but vanished until in these days the search for trouble has resolved itself, for the most part, into a simple lifting of the bonnet.

It is the same thing in the way of reaching parts to be oiled. The oiling spots on the automobile are well defined and the schedule of oiling has been reduced to a basis of hours and quarts or in other cases to miles and quarts. The motor is always mechanically lubricated and once the oil is in the reservoir the operator need not bother about it until the level gauge indi-

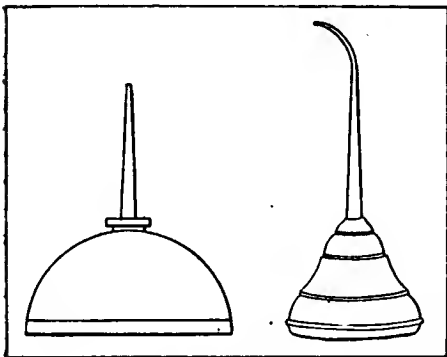

Fig. 3—Two oil cans may be carried for gasoline and oil

cates to him that the supply is running short and should be replenished. A small oil can will be of use to the automobile driver; in fact, two of them should be carried, with different-shaped nozzles, one for oil and the other for gasoline, as shown in Fig. 3. The gasoline should be carried in the can with the straight nozzle and the oil in the can with the curved nozzle. The gasoline will be found to be of a variety of uses such as priming the motor and

cleaning the hands after working about the engine.

It will often be found advisable to put a drop or two of oil at different points, and the oil can will be found to be of the greatest convenience. There are several points which are beyond the classification of regular lubricating points, such as the compression cock handles, magneto and water pump bearings, etc. These require a few drops occasionally where they are not provided with grease cups. A grease gun is often of use in putting the lubricant in its proper place.

**USING THE SPANNER WRENCH**—One of the most important tools in the kit is the

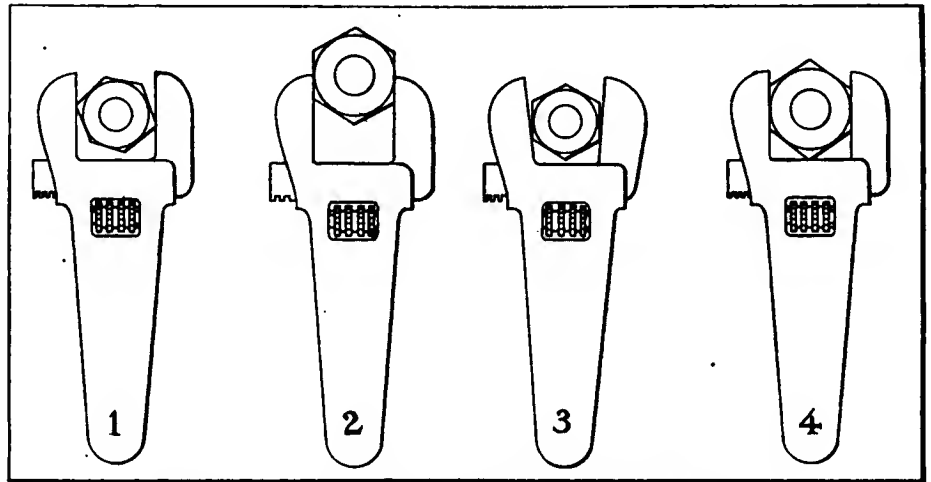

Fig. 4—Showing the use and misuse of an adjustable spanner-wrench

spanner-wrench, yet it is capable of much damage to nuts and bolt-heads when improperly used. The number of cars to be seen in which there is tell-tale evidence that the owner or driver does not yet know how to properly manipulate the tool is surprising. This may be due as much to carelessness as to neglect, but nevertheless the burred nuts speak for themselves. Of course, these remarks apply principally to the adjustable spanner, the ordinary standard spanners not admitting of serious misuse, since they can be used only on the size nuts for which they were made. In using the spanner it is essential to get as firm a grip as possible on the sides of the nut. If improperly adjusted as shown at 1, Fig. 4, the corners of the nut are sure to be worn away, or badly burred, and, if the practice is continued, the nut soon becomes useless until new faces are made on it. This is true particularly of brass or bronze nuts, or others made of soft material. Another misuse is that of not putting the wrench far enough on the nut, as shown at 2. While this also tends to burr the corners of the nut, it spreads the jaws of the wrench and strains them so that when next applied to a nut, they will not fit accurately, as shown at 3. At 4, in Fig. 1, is shown the proper way to use

the tool, the jaws being given as much bearing surface as possible on the faces of the nut. When adjusted in this way there is little danger of rendering impossible the removal of the nut after about the third time. Never apply too much force when tightening up a nut. It is possible to strip the thread, or, worse yet, to turn the end of the bolt off by using a heavy, long-handled wrench on a small nut. Few realize the enormous force which can be exerted by a long-handled wrench, even when the force applied is not very great. Another mistake is to use pliers for the adjusting of small nuts, such as those on the magneto or carbureter. A small spanner is far better for the purpose and should be used wherever possible. The

ease with which these small nuts are burred makes it necessary to be very careful when applying even a spanner to them.

**CLEAN DIFFERENTIAL HOUSINGS**—It is occasionally necessary to remove the cover from the differential housing and give the contents of this casing a thorough cleaning and overhauling. If long life is desired in all parts of the motor, cleanliness will be the great means of securing it. In cleaning the differential housing the cover is removed and the casing flushed out with kerosene. The motor is then allowed to run for a few seconds and the casing again flushed out, after which it is refilled with the particular oil or grease recommended by the manufacturer. The casing is then screwed into place. There is generally a cock in the bottom of the differential housing through which the kerosene is drained before the housing is refilled.

In replacing the cover after putting in the grease, care should be taken in tightening up the screws that hold the cover in order not to turn off a head. When this happens, it is rather hard to get at this part of the car to remove the portion of the screw remaining in the tapped hole.

# My Best Automobile Repair

## Some Quick Repairs Made in the Garage and on the Road

### A Gasoline Gauge

Editor THE AUTOMOBILE:

I read with interest the suggestions for repairs and of the improvements which others have made on their machines, and I am sending you a sketch showing a gasoline gauge which I have fitted to my tank, the latter being under the front seat. This has proven very satisfactory, and is inexpensive. If you deem it worth publishing, it may interest someone else. Fig. 1 shows the gauge D attached to tank A. Two 1-4-inch unions C are used, and the stop-cock B is included so that the gasoline may be shut off in case the glass breaks. A detail of the gauge proper is shown to the right. The brass caps E are tapped for a 3/16-inch brass rod F, which secures the 5-8-inch steam boiler gauge glass G. The pipe connections to the tank are shown at H. Leather washers should be placed at K to prevent leakage.

ELMER C. NORTH.

Juniata, Pa.

### When the Gasoline Gives Out

Editor THE AUTOMOBILE:

"The gasoline tank is empty." What a hollow sound these words have if one is stranded a few score miles from home! But don't give up the ship. Just disconnect the tubing which supplies the acetylene gas to the headlights and insert it in the primary air intake of the carbureter, as shown in Fig. 2. Turn on the gas and adjust it so that the motor will run well at a moderate speed, and proceed on your homeward way. Of course, the speed of the engine cannot be controlled very well, because the supply of gas remains constant and does not vary with the suction as does the liquid gasoline. However, by

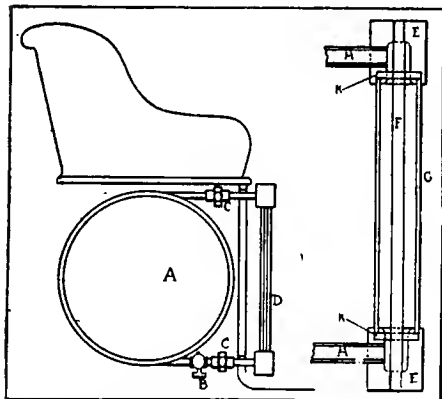

Fig. 1.—Suggested form of gasoline gauge

*Temporary automobile repairs made by the driver or owner while on the road and permanent repairs made in the garage after the run is over, are interesting to all automobile owners.*

*It may be a spring leaf has broken; a shackle bolt or strap may break; a steering tie rod is bent; the car skids into a curb and bends a steering arm or the starting crank; a throttle or magneto connection breaks owing to vibration; a radiator leak is started by a stone or some other means; a leak in the gasoline tank is discovered; there is a small hole in the gasoline feed line; a brake facing may burn out; a brake connection breaks; a front axle gets slightly sprung; a clutch starts slipping, or any one of a thousand things may happen.*

*Every automobile owner is interested in knowing how repairs have been made, how long it took to make them, how much they cost, and by whom they were made.*

*We want you to write in simple language in a letter what repair of this nature you have had to make, how you made it, how long it took you and how much it cost.*

*You can make with your lead pencil one or two rough sketches indicating the broken or damaged part and showing how the repair was made.*

*The experience of each reader is interesting to every other reader. Analyse your past experiences and send in one or two of them.*

*Give your name and address, legibly written. If you do not want your name to appear, make use of a nom de plume.*

Editor THE AUTOMOBILE.

proper manipulation of the spark lever, one may "get there."

MURRY FAHNESTOCK.

Allegheny, Pa.

### That Tire Pump

Editor THE AUTOMOBILE:

Mr. Ed. C. Bates, in the October 26th issue, described a method of making a tire pump. I made one according to directions, I believe, but could not get any air into my tires. I have a two-cylinder motor, which perhaps runs too fast, and I cannot throttle it down as far as a four-cylinder motor. I would be greatly pleased to make this pump and would like to have further directions.

Atkinson, Ill.

THEO MILLER.

Editor THE AUTOMOBILE:

In your issue of October 26 there appeared an article which gave directions for making a tire pump and asking the opinions of readers on the contrivance. I would say that I have followed these instructions, using the pump on a four-cylinder engine with a bore and stroke of 4 1/4 inches by 4 1/4 inches, and the same will absolutely

not work. It is only a waste of time and material to experiment with such a contrivance on an engine of this size.

Albany, N. Y.

H. M.

Editor THE AUTOMOBILE:

In the October 26th issue of THE AUTOMOBILE on page 728 is a sketch and description of a home-made tire pump, operated by screwing it into the engine cylinder in place of the spark-plug. I would like to know if such a pump would operate properly in connection with an L-head or a T-head motor. Would pure air or a mixture of gas and air be delivered to the tire, and, if any gas, approximately how much and what would its effects on the tire be? In addition to your direct answer, I would like to see replies from some users of such a device, either home-made or such types as are regularly for sale.

Pittsfield, N. H. WILLIAM B. ELY.

Has any reader constructed this pump and made it work satisfactorily? The suggestion and sketch were submitted by Mr. E. C. Bates, of Clarksville, Tenn., and while THE AUTOMOBILE has not actually constructed the apparatus, the idea appears to be reasonable, although perhaps rather impractical. If it will work at all, there is no reason why it will not operate equally well on either a T-head or an L-head type of cylinder, since it depends for its operation on the compressive force and not on the cylinder design. A mixture of gas and air would be delivered to the tire, but the amount of air in proportion to the amount of gas would no doubt be great enough to counterbalance any ill effects which the gas might possibly have. Perhaps Mr. Bates can explain why these correspondents have not been successful with his contrivance, and can give more light as to its construction and manner of operating.—EDITOR.

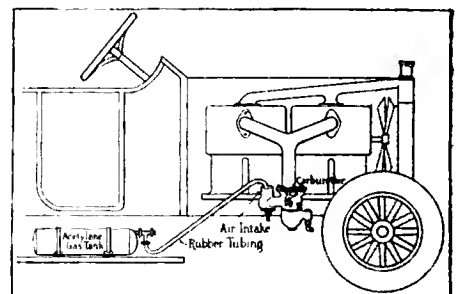

Fig. 2.—Emergency use of acetylene gas to run motor when gasoline supply is exhausted

# My Ideal 1912 Automobile

## Readers' Conceptions of What Next Year's Car Should Be

### Perhaps You Are Right

Editor THE AUTOMOBILE:

In THE AUTOMOBILE for October 26 Mr. P. G. Tismer gives his idea of what a low-priced car should be. His is certainly a most desirable car. I would suggest, however, that besides doing away with the carbureter the engine should also be omitted, for even a single-cylinder engine is more or less complicated and I think that Mr. Tismer's car would run just as well without the engine. I am sure that it would coast better without this complication and the control would be greatly simplified, for even the spark advance and transmission could be done away with. I am glad to see that "mud guards and top are put in position when needed." I presume that these useful accessories are folded up somewhere in the body of the car and, if the driver should be unfortunate enough to encounter a rainstorm while out on the road, he would only need to pull them out, adjust them and bolt them on his car—a simpler operation, surely, than raising an umbrella.

BARRY MACNUTT.

South Bethlehem, Pa.

### From a Racing Driver

Editor THE AUTOMOBILE:

I have been asked to state my ideas of what would be considered a first-class fool-proof automobile for the general public to own. By general public, I mean the people who own and run their own machines, and who have little or no knowledge of what is under the hood and footboards.

To start with, I would have a reinforced, pressed-steel frame. I have seen so many frames on good cars that would sag in the center or crack near the dashboard that I believe they should be reinforced in these places. The springs should be elliptic and should be of ample size to withstand the jar of the machine over rough roads without fear of breakage. I also believe there should be straps on the springs to eliminate the rebound, as it is not the contraction of the springs that breaks them, but the rebound.

The engine should have a bore of about 4 1-4 inches or 4 3-4 inches and a stroke of either 5 inches or 5 1-2 inches. The valves should be large, and the connecting-rods should be strong enough to withstand the power of the explosions. A good splash-feed oiling system that could be relied upon to do its duty at all times should be used.

*Readers continue to demonstrate their interest in the ideal car and the specifications which are submitted show a wide range of taste and requirements. In view of the interest shown the Editor continues to extend the invitation to all who entertain ideas on this absorbing topic, to submit their opinions for publication. The description should be legibly written on one side of the paper and signed by the sender, although if it is so desired the name will not be published.*

The engine should be strong and simple, and built so as to be easily accessible in case of emergency.

I would use a Remy magneto, which is simple and easy to adjust, also a model L Schebler carbureter, which is about as fool-proof as any carbureter made. The latter may use 5 cents' worth of gasoline more a month than some others, but it will always get you home.

A cone clutch with spring inserts gives one as much satisfaction as any other kind. It never runs dry of oil, and, with a little care, will give good satisfaction. A three-speed selective-type transmission made of good materials and of sufficient strength will prove satisfactory.

A full-floating, ball-bearing rear axle fitted with internal and external brakes would be desirable, and I would have 34-inch by 4-inch wheels. The B. & L. caster front axle would put the car under absolute control of the driver, would eliminate a great many accidents and would also leave the driver's arms and shoulders in a better condition at the end of the day's run. This axle makes the car 90 per cent. easier to control. I am a racing driver, and I believe that before long all the leading factories having racing teams will equip their cars with the B. & L. front axle, in order to insure their drivers' safety. Otherwise, there are so many drivers being killed that there will soon be a scarcity. Factories will have to insure their drivers' lives by putting this axle on their cars.

HARRY BUCKLEY.

### Cars Good Enough as They Are

Editor THE AUTOMOBILE:

To my mind, several of the cars which are being shown for next year come as near to the ideal as we are apt to get with the knowledge which the automobile engineering fraternity has at its command at the present time. Some readers' opinions are so radically different from the actual models as produced by engineers who have had many times their experience, that they are freaks even on paper. The auto-

mobile of to-day has passed beyond the freak and experimental stage, and the better makes are as near to mechanical perfection as can be desired. Besides being correctly built mechanically, they are built so as to be a comfort and pleasure to the motorist. Accessories are placed in a particular place only after careful consideration as to their accessibility. Springs and shock absorbers have at last been constructed in such a way as to make easy riding the rule rather than the exception. Self-starting and electric lighting make it unnecessary for the driver to leave the car to light the lamps or to start the motor. In a word, the noisy makeshift cars of the past have been superseded by the silent, smooth-running machines of the present. No longer is the monster's approach heralded for several miles before it actually appears. The days of such nuisances are past and now we have gasoline cars which are equal to electrics without the latter's disadvantages of limited mileage and small capacity.

Therefore, why suggest radical changes, when if the wise manufacturers had deemed them necessary they would have long since been incorporated in the existing models?

The long-stroke motor has advantages which cannot be overlooked, so in my car I would specify this feature. I would require ample power so that I would not have to take the other fellow's dust or have to resort to the low gear to take me over steep hills. The motor would have six cylinders, as for smooth riding and easy running and for flexibility there is nothing, in my opinion, equal to the six. Flexibility cannot be too highly praised especially where the car is to be used in heavy city traffic. Any of the high-grade power plants would be acceptable, preferably one which had three-point suspension. The carbureter should have two jets, and there should be an auxiliary air valve, which could be adjusted from the seat.

I would want the latest type of body construction, with the control levers in the center of the car. With the prevailing types of fore-door models, there is scarcely room on the right side for these levers. This also admits of access to the driver's seat from the right side of the car.

Such a car as I have outlined could not be bought for a song, but would possibly cost anywhere from \$3,500 to \$5,000, although there are several worthy machines for 1912 at a much lower figure.

CHAS. E. HAMMOND.

Chicago, Ill.

# Automobile Metallurgy Made Easy

By E. F. LAKE

## Part II. The Elastic Limit

Value of This Factor in Different Materials  
Entering Into the Automobile Make-Up—How  
Obtained and Why It Is Necessary

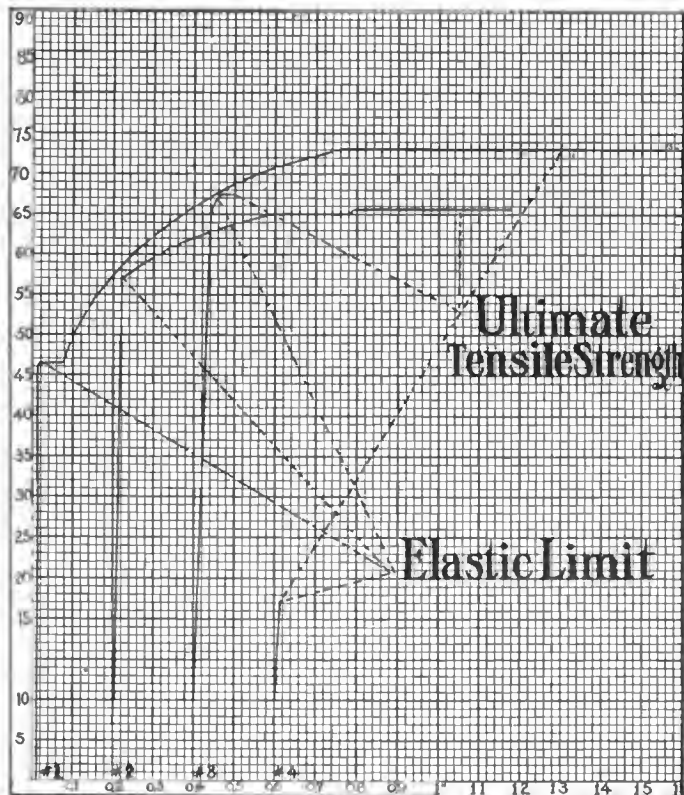

Fig. 1.—Chart showing tensile strength, elastic limit and elongation. No. 1, machinery steel; No. 2, cold-rolled steel; No. 3, brass; No. 4, cast iron.



**A**FTER the tensile strength has been considered, the most important factor in the strength of metals is the elastic limit. In pulling test bars apart in the tensile testing machines, shown in Part I, they will stretch a certain distance and then spring back to their original length. When stretched a little further, however, a permanent set takes place and from this they will not spring back. The point between these two is called the elastic limit, *i. e.*, the limit of the elasticity of the metal.

The difference between the pounds pull required to make the metal first take this permanent set and that required to reach the ultimate tensile strength and break the specimen varies considerably with different metals. In pulling test bars apart a gradual rise in the number of pounds is shown by the scale beam from the time the pull is started until the elastic limit is reached. When the permanent set first takes place the scale beam halts, in its upward motion, for a fraction of a second and then shows a more gradual rise from this point until the limit of the tensile strength is reached and a break occurs. This is due to the metals stretching much more when the elastic limit is passed than they do before it has been reached.

With most tensile machines, such as are shown in Part I, on tensile strength, a chart is provided and on this is lined, with a stylographic pen, the action of the scale beam. A reproduction of such a chart is shown in Fig. 1. In this chart line 1 shows

the results obtained with a machinery steel test bar; line 2 those obtained from a test bar of cold-rolled steel; line 3 is that traced from a brass test bar, and line 4 is the verdict acquired by pulling apart a cast-iron test bar. As will be seen, cast iron is brittle, has almost no elasticity and hence breaks at the elastic limit; brass has very little elasticity and breaks slightly above the elastic limit; cold-rolled steel shows some 8,000 pounds difference between the elastic limit and the ultimate tensile strength and machinery steel shows 26,500 pounds difference.

Many have argued that after the elastic limit of a metal has been passed its usefulness is destroyed. They base their argument on the statement that a given material might stretch for a long distance before breaking. They cite putty and other plastic materials as examples of this. Such arguments come, however, from a consideration of only a part of the problem strength of materials or from those who only know half of the truth.

As an example of this, steel wires, rods and cables that perform a work such as those do in the Brooklyn bridge might be loaded to 46,500 pounds per square inch and take a permanent set or reach their elastic limit if made from the machinery steel shown in the chart, Fig. 1. Their usefulness would not then be destroyed, as it would take 26,500 pounds per square inch more, or a total of 73,000 pounds, before a break would occur.

The frame of an automobile might be compared to the materials in a bridge, as it performs a similar work. The elastic limit of this may be considerably exceeded without causing it to break, and the breakage of the frame is the real important factor. Many an automobile has had its frame twisted and bent out of shape. This frame has been straightened and the car made to do its daily work thereafter. In these twists and bends the elastic limit has been exceeded but the ultimate strength has not been reached, hence the cars are as good for practical use as they were before. Even gear teeth, after they have been worn considerably, might be strained until the elastic limit was exceeded and thus be permanently bent. After that they might do a lot of work owing to their not having been strained until the ultimate tensile strength had been reached and the teeth thus broken.

A few cases of this nature, however, do not prove that the elastic limit of metals is not of vital importance. Most parts of a car should retain their original size and shape, if the car is to work properly and have a long life. If the elastic limit of many of the working parts is exceeded, their size is altered and they will not fit properly. This would cause them to interfere with other parts and hence clog them or seriously hinder their movements. In such places the elastic limit of the metals cannot be exceeded, and these are usually the parts that require the very strongest of materials. It is, therefore, the aim of many automobile designers to obtain materials in which the elastic limit can be raised up close to the ultimate strength and thus enhance their usefulness.

The elastic limit, as well as the tensile strength, can be greatly increased by a proper manner of heat-treatment, *i. e.*, hardening



and tempering. Many of the special alloy steels have been adopted for various important car parts, as with these the tensile strength can be raised to a high figure and the elastic limit brought up closer to it than can be done with the ordinary carbon steels. Nickel, nickel-chrome, vanadium and titanium steels can all be worked and heat-treated so as to bring the elastic limit up close to the tensile strength. This is well illustrated by the table herewith. Raising the elastic limit close to the tensile strength also greatly enhances the resistance of steel to torsional and impact strains, and to rotary and alternating vibrational stresses. Many parts of an automobile are subject to extreme strains and stresses of these natures.

All steels are much lower in tensile strength and elastic limit when in an annealed or normal condition than when correctly heat-treated. As they are shipped from the steel mill in this annealed condition they must be properly heat-treated in the automobile factory before they are put on the car. The difference of strength between annealed and heat-treated steels of various kinds is also well shown in the table. All of these cases show the importance of knowing the elastic limit as well as the tensile strength of the various metals used in a motor car.

Careful car builders pull apart sample test bars from each lot and kind of metal ordered and do not leave this to chance. The elastic limit is then always given with the tensile strength. It is, therefore, not difficult for the buyer, user or seller to obtain the information that is necessary for a thorough knowledge of the car's mechanism.

TABLE SHOWING THE EFFECT OF HEAT TREATMENT ON THE TENSILE STRENGTH AND ELASTIC LIMIT.

Kind of Steel.	ANNEALED STEEL.		HARDENED STEEL.	
	Pounds per Square Inch of			
	Tensile Strength.	Elastic Limit.	Tensile Strength.	Elastic Limit.
Very low carbon.....	61,500	35,200	73,100	39,600
Low carbon.....	66,500	41,200	99,400	54,000
Medium carbon.....	97,800	52,600	132,100	81,400
High carbon.....	116,400	66,500	153,400	102,100
Very high carbon.....	130,700	75,800	180,100	105,500
Nickel.....	88,000	60,000	225,000	224,500
Nickel.....	87,640	64,400	125,000	103,000
			127,800	110,100
			130,500	124,000
			138,000	127,500
			147,000	140,750
			212,000	200,000
			232,750	224,000
Chrome nickel (soft).....	114,000	93,000	206,000	185,000
Chrome nickel (hard).....	135,000	107,000	285,000	270,000

### Removing Odor from Rubber Articles

Rubber mats in the interior of closed automobiles are frequently objectionable by their odor. This can be removed, however, by subjecting them to the same process which is employed in the case of small articles of vulcanized rubber, such as tobacco-pouches and dress-shields, which are carried on the person. The articles to be deodorized are placed in a metal box between layers of finely pulverized carbonized bone, and the box is then left for four to eight hours, according to the size of the articles, in a place, such as a drying room, where a temperature of 60

to 70 degrees Centigrade can be maintained. If the bonemeal is to be used again for the same purpose, it must first be brought to red heat in a closed metallic vessel, in the cover of which there must be a vent, and it must be left to cool therein. The deodorized rubber articles must not be placed together with other rubber articles which have not been so treated, as they will acquire their old odor again, in that case, with surprising rapidity. Unburned magnesia powder can also be used for removing the odor. Merely sprinkling it over the article will have some effect.—From *Gummi Zeitung*, August.

## Calendar of Coming Events

- Shows
- Dec. 30-Jan. 6.....Buffalo, N. Y., Annual Show, Seventy-fourth Regiment Armory, Buffalo Automobile Trade Association.
  - Jan. 2-11.....New York City, Hotel Astor, Importers' Salon.
  - Jan. 6-13.....New York City, Madison Square Garden, Twelfth Annual Show, Pleasure Car Division, Automobile Board of Trade.
  - Jan. 6-20.....New York City, Madison Square Garden, Annual Show, Motor and Accessory Manufacturers.
  - Jan. 10-17.....New York City, Grand Central Palace, Twelfth Annual Show, National Association of Automobile Manufacturers; also Motor and Accessory Manufacturers.
  - Jan. 13-27.....Philadelphia, Annual Show, First and Third Regiment Armories, Philadelphia Automobile Trade Association.
  - Jan. 15-20.....New York City, Madison Square Garden, Twelfth Annual Show, Commercial Division, Automobile Board of Trade.
  - Jan. 13-19.....Milwaukee, Wis., Auditorium, Fourth Annual Show, Milwaukee Automobile Dealers' Association.
  - Jan. 22-27.....Detroit, Mich., Wayne Gardens, Eleventh Annual Show, Detroit Automobile Dealers' Association.
  - Jan. 22-27.....Providence, R. I., Providence State Armory, Rhode Island Licensed Automobile Dealers' Association, Automobile and Accessories Show.
  - Jan. 27-Feb. 10....Chicago Coliseum, Eleventh Annual Automobile Show under the auspices of the National Association of Automobile Manufacturers. Pleasure cars, first week. Commercial vehicles, second week.
  - Jan. 27-Feb. 10....Pittsburgh, Pa., Sixth Annual Show, Automobile Dealers' Association of Pittsburgh, Inc. Pleasure cars, first week. Commercial vehicles, second week.
  - Jan. 29-Feb. 3.....Scranton, Pa., 13th Regiment Armory, Second Annual Show.
  - Feb. 1-7.....Washington, D. C., Annual Show, Convention Hall.
  - Feb. 3-10.....Montreal, Canada, National Show, Drill Hall, Automobile Club of Canada.
  - Feb. 5-17.....St. Louis, Mo., Coliseum, Annual Show, Pleasure cars, first week. Commercial vehicles, second week.
  - Feb. 12-17.....Ottawa, Ont., Howick Hall, Annual Show, Ottawa Valley Motor Car Association.
  - Feb. 12-17.....Kansas City, Mo., Annual Show, Combined Association of Motor Car Dealers.
  - Feb. 14-17.....Grand Rapids, Mich., Third Annual Show.
  - Feb. 17-24.....Pittsburgh, Pa., Second Annual Show, Exposition Bldg., Pittsburgh Auto Show Association, Inc.
  - Feb. 17-24.....Newark, N. J., Fifth Annual Automobile Show, New Jersey Automobile Exhibition Company, First Regiment Armory.
  - Feb. 17-24.....Minneapolis, Minn., National Guard Armory and Coliseum, Annual Automobile Show, Minneapolis Automobile Show Association.
  - Feb. 19-24.....Omaha, Neb., Seventh Annual Show, Auditorium, Omaha Automobile Show Association.
  - Feb. 19-24.....Hartford, Conn., Annual Show, Automobile Club of Hartford, State Armory.
  - Feb. 20-24.....Binghamton, N. Y., State Armory, Third Annual Show, Automobile Dealers' Association.
  - Feb. 20-28.....Baltimore, Md., Annual Show, Baltimore Automobile Dealers' Association.
  - Feb. 21-28.....Toronto, Ont., Annual Show, Toronto Automobile Trade Association.
  - Week Feb. 22.....Cincinnati, O., Annual Show, Cincinnati Automobile Dealers' Association.
  - Feb. 24-March 2...Brooklyn, N. Y., Twenty-third Regiment Armory, Annual Show, Brooklyn Motor Vehicle Dealers' Association.
  - Feb. 26-Mar. 2....Elmira, N. Y., Second Annual Show, Elmira Automobile Club.
  - Feb. 26-Mar. 2....Paterson, N. J., Annual Show, Fifth Regt. Armory, Paterson Automobile Trade Association.
  - March 2-9.....Boston, Mass., Tenth Annual Show, Boston Automobile Dealers' Association, Inc.
  - March 4-9.....Denver, Col., Auditorium, Annual Show.
- Meetings, Etc.
- Dec. 20.....New York City, Waldorf-Astoria, Annual Banquet of the Automobile Club of America.



Vol. XXV Thursday, November 30, 1911 No. 122

**THE CLASS JOURNAL COMPANY**

H. M. SWETLAND, President

CONDE NAST, Vice-President and General Manager

E. M. COREY, Secretary and Treasurer

231-241 West 39th Street, New York City

Cable Address - - - - - Antoland, New York  
 Long Distance Telephone - - - - - 2046 Bryant, New York

**SUBSCRIPTION RATES**

United States and Mexico - - - - - One Year, \$3.00  
 Other Countries in Postal Union, including Canada - - - - - One Year, 5.00  
 To Subscribers—Do not send money by ordinary mail. Remit by Draft,  
 Post-Office or Express Money Order, or Register your letter.

Entered at New York, N. Y., as second-class matter.  
 The Automobile is a consolidation of The Automobile (monthly) and the Motor  
 Review (weekly), May, 1902, Dealer and Repairman (monthly), October, 1903,  
 and the Automobile Magazine (monthly), July, 1907.

**Growth of Automobiles**

FEW statements show better the growth of automobile traffic in the country than those made by Colonel William D. Sohier, high commissioner of the State of Massachusetts, at the recent good roads convention at Richmond. In order to get an accurate estimate of the kinds of traffic on the roads of the state 240 stations for counting traffic were selected along these highways. For 14 hours each day and for 7 days in August and 7 days in October this count was carried on. By this actual method of counting it was discovered that on some of the leading state roads 90 per cent. of the traffic was of the motor car variety and that as many as 1,190 cars passed a given point in a single day. Roughly, the fact showed that on some of the roads adjacent to Boston, where mixed traffic was expected, over 60 per cent. of the vehicles were motor-driven. When the average for all of the stations throughout the entire state was taken it was discovered that on the 7 days in August 42 per cent. was motor traffic and in October 35 per cent. motor and 65 per cent. horse traffic. Before these figures were announced it was commonly stated that horse traffic was nearly five times as great as motor traffic, a claim doubtless due to the fact that horse traffic moves slowly and that a horse vehicle may be seen many times on the highway before it has vanished from sight, whereas the motor vehicle is generally seen but once and that for a very short time before it vanishes from sight. This count has demonstrated to the people of Massachusetts that the motor vehicle will in perhaps another year have dislodged the horse vehicle from the position of premier-ship it has occupied.

The big lesson in the above figures is the application of this truth to the good roads problem. Up to the present the farmer and many legislators have urged that owing to the motor vehicle constituting a small percentage of the total traffic it should not receive as much consideration in the road building business as the horse-drawn vehicle. This count establishes beyond the shadow of a doubt that when road building is under consideration

in that state those kinds of roads best suited to the motor car should be first considered. The days were when in building a road the question was to build a road for horse traffic; to-day this is changed and the problem is to build a road suited for motor vehicle traffic. The last few years have proven that roads suited for horse traffic are not suited for motor traffic. The macadam which is successful for horse traffic is an utter failure for motor traffic and states that are building macadam roads to-day and expecting them to endure will be disappointed in less than a year. The road for the motor vehicle requires a good binder, a substance that will hold the road material together, a substance that prevents disintegration due to too much moisture and a substance that will bind the road surface together in dry weather and so prevent dust. Many state road commissioners have known for years the kind of road best suited for motor traffic, but owing to the imagined preponderance of horse traffic they have not dared to build the motor road. Massachusetts deserves credit in setting an example to other states. It is questionable if in any other state the percentage of motor vehicle traffic is so heavy, but the truth is always strong and it would be well for others to get the exact status of the road traffic.

One of the factors much in favor of motor traffic is the low percentage of accidents with automobiles as compared with horse-drawn vehicles. Roughly speaking the accidents with trolley cars per mile traveled is eight times that of motor vehicles. From newspaper accounts it would seem that with the automobile the number was many times greater per traveled mile than with the trolley. The trolley with its own right of way and its confined road of travel should not meet with so many accidents as the newly arrived motor car. These facts speak well for the control of automobiles as well as for the caliber of the people operating them.

So great has the motor industry become in the older states that the old-time antipathy is not encountered and in the new states of the West so many of the farmers are buying cars and this new method of transportation is so popular that the antipathy that is sometimes shown in the East will never exist there. It is fortunate that the good roads movement is rising with the waning of the antipathy, because it brings farmers and car owners together in the work that is so much needed. It is questionable if there is any other force of greater influence in winning interest in good roads than the fact that the car has been taken up in the small towns and cities where the farmer gets closer to the machine owner than he does in the big cities. Once the farmer owns a car, be it ever so small, or rides in one, he becomes a convert to the good roads cause and as soon as one farmer is won over the others soon follow. The modern automobile is a great educator and the road improvement made during the last year in such states as Iowa and Georgia, to which might be added Nebraska and Colorado, is largely due to the education worked and inspiration stimulated by the car. To-day delegates are going to the good roads conventions in their motor cars instead of in the trains. Some delegates tried to reach the Richmond convention of last week in their cars but failed because of the deplorable condition of the roads. Their failure has but created a stronger conviction for the necessity of good roads. The automobile has been largely responsible for this situation.

# News of Shows, National and Local

WITH seventy manufacturers of commercial vehicles and 138 parts and accessory makers signed up to show at Chicago, truck week prospects for the annual automobile show present brilliant possibilities. It has been estimated that the use of commercial vehicles in Chicago territory has increased 35 per cent. during the past year, and the business element of the territory is much more intensely interested in automobile trucks than it was formerly. Consequently, a larger patronage of the coming show is looked for than ever before.

The poster which will be used to advertise the Madison Square Garden show of the Automobile Board of Trade has made its appearance. The subject is an Oriental girl bedecked with Eastern jewels and wings. She stands with arms outstretched, holding a passenger automobile in one hand and a business wagon in the other.

Only progress was reported on the plans of the new show building which will be erected north of the present Grand Central Palace. After they are completed it will be necessary to lay them before the New York Central for approval and pending such approval the authorities decline to give out anything official.

## Plans for Washington Exhibition

WASHINGTON, D. C., Nov. 27—Plans are under way for the annual motor car show under the auspices of the dealers of this city. A meeting was held this week, which was attended by thirty-three dealers, representing eighty-five different makes of cars, and the following show committee was elected: W. C. Long, chairman; John R. Thomas, secretary; J. M. Stoddard, treasurer; Claude Miller, T. S. Johnston, Taylor Pollock, E. C. Bull, and S. A. Luttrell. February 1-7 were the tentative dates agreed upon.

There is also some question whether Convention Hall, which is the only available place in which to hold a show, can be obtained on that date. It was decided to confine the show to pleasure cars, eliminating accessories and motor trucks. This decision caused a slight row among those who were thus barred from the show, but as the pleasure car dealers were in large majority and as there was every assurance that every inch of space would be taken by them, the decision was allowed to stand. Drawing for space will take place within the next two or three weeks.

## Detroit Dealers' Show January 22-27

DETROIT, MICH., Nov. 27—Practically every Detroit manufacturer of motor cars and no less than 35 dealers, handling all the best-known cars manufactured in this country, will be represented at the 1912 show of the Detroit Automobile Dealers' Association, to be held in the Wayne pavilion, January 22 to 27.

Those who have already secured space are: The Regal Motor Car Co., the Elmore Automobile Co., the Chalmers Motor Co., Cartercar Co., Cadillac Motor Car Co., Olds Motor works, Standard Automobile Co., representing the Packard Motor Car Co.; Winton Motor Car Co., Brush-Detroit Motor Co., Neumann-Lane Co., agents for the Pierce, Stoddard-Dayton and Rauch-Lang cars; the Buick Motor Co., Lozier Motor Co., Cunningham Auto Co., agent for the E-M-F and Flanders cars; the Ford Motor Co., Abbott-Detroit Motor Co., Lion Motor Sales Co., Seidler Motor Sales Co., agents for the Jackson car; Warren Motor Car Co., Gant Bros. Auto Co., agent for the Everitt and Amplex cars; United Motors Detroit Co., representing the Maxwell cars and the Sampson truck; Thompson Auto Co., agent for

the King car and the Van Dyke and Mack trucks; the General Motors Co., showing the Reliance and Rapid, Buick and other commercial vehicles; J. P. Schneider Co., representing the Stevens-Duryea car; Detroit Hupmobile Co. and the Gillespie Auto Sales Co.

The following independents have applied for space: Anderson Electric Car Co., maker of the Detroit Electric; the Motor Wagon Co., Oakland Motor Sales Co., the Paige-Detroit Motor Car Co., the Hupp Corporation, representing the R. C. H. car; Foster Motor Sales Co., the Church-Sibley Co., the manufacturers of the Paterson Car and others.

## S. A. E. Party Ready to Sail Home

Advices cabled from Paris by Coker F. Clarkson, secretary and general manager of the Society of Automobile Engineers, make the announcement that the delegation from the society which has been spending a month inspecting British and Continental factories and engaging in scientific conferences will sail for New York on the steamer *Olympic* November 29.

Mr. Clarkson says that the visit has been a great success in every way, and that the foreign manufacturers have done everything possible to assist the visitors. Not all the party will return on the *Olympic*, as quite a number will remain abroad for several weeks longer to make more detailed inspections and to go into fields not touched by the regular itinerary. Plans for the annual meeting of the society are being matured and it is expected that the Madison Square Garden program will include forty or more formal papers in which the commercial vehicle will come in for considerable consideration.

## Solid Tire Patent in Federal Court

Orders issued by the United States Circuit Court in the suits of the Consolidated Rubber Tire Co. against the Goodrich, Republic Rubber and Morgan & Wright companies, based upon the alleged infringement of the Grant patent on solid tires, allow each of the three defendants 60 days in which to plead to the complaints.

The suits were instituted about two years ago and have lain practically dormant pending a decision of the patent by the Supreme Court. This was handed down last spring, and now the present suits will be determined.

The complaining company alleged that the Grant patent was valid and belonged to it and charged that the defendants infringed it. Preliminary injunctions were issued and the cases will be tried upon their merits, probably at the spring term of court. The plaintiff company seeks permanent injunctions, an accounting with each defendant and damages.

## Rubber Sellers Sue Michelin

Echoes of the explosion of the late rubber bubble were heard in New York last week when Poel & Arnold entered seven suits against the Michelin Tire Co. based upon alleged contracts of sale made during the period of market inflation in the early part of 1910. It is charged by the complaining company that the defendant refused to accept the rubber sold and that in consequence of the falling market since that period the sellers lost a considerable amount.

The matters will hardly be ready for trial until next spring.

**L**ONDON, Nov 20—How London secures the best cab service in the world at a lower price than any other city was revealed in a visit which the members of the Society of Automobile Engineers made to the depot of W. & G. Du Cros, Ltd. London possesses between 7,000 and 8,000 motor cabs plying for hire at the uniform rate of 16 cents for the first mile and 4 cents for each additional quarter mile.

Messrs. W. & G. Du Cros operate 1,200 cabs and always have 1,050 in use, the remainder being in the depot for overhauls and repairs. Napier has supplied 800 of the chassis and Panhard 400, all being four-cylinder models of practically 80 by 120-millimeter bore and stroke. The organization is such that the cabs are in service every day. There is one driver per cab, the system of double shifts having been found to be unsatisfactory, and each driver must keep his cab out 12 hours per day.

Payment is made on the basis of 25 per cent. of the net takings, the driver buying his gasoline from the company at cost price, 18 to 20 cents per gallon, and being provided free with everything else necessary for running. It is the company's task to so organize their depots that no cab shall be kept off the street except for the periodical overhauls.

It was explained to the visitors how, after coming in at night, every cab was got ready for the road the next morning, no matter what its condition, after a hard day's work punctuated with accidents. Only a complete wreckage of the cab would necessitate its stoppage in the depot for more than one night. In addition to washing, inflating tires, filling tanks, oiling, touching up paint work, etc., the organization is so good that such serious damage as the breakage of the crank hangers, the rupture of the differential or the changing of the gearbox could be repaired between midnight and 10 o'clock the next morning. The company buys its own tires, of 815 by 105 millimeter section, and by a systemized method of nightly examination and repair whenever necessary can get a much higher average in the hands of rough drivers than is possible by many private car owners. Two steel-studded tires are used, one on the rear, and the other on the opposite front wheel.

Each cab travels from 60 to 80 miles a day, two-thirds of this distance being on paying trips. The minimum earnings are \$8 per day, of which amount the driver will keep \$2. Depreciation is based on a period of seven years, and, according to the engineer in charge, the cabs which have already been in service three and one-half years are in every respect equal to new. The cabs cost from \$1,500 to \$1,700 complete. The recording instrument is not included in the amount, this being rented from the taximeter manufacturing companies.

## What S.A.E. Tourists

One hundred and forty persons, about forty of whom were members of the Society of Automobile Engineers, united at the Trocadero restaurant, Piccadilly, London, for the banquet given by the Institution of Automobile Engineers in honor of the visit of the Americans. The chair was occupied by L. A. Legros, M.Inst.C.E., and president of the Institution of Automobile Engineers. After the toasts of the King and the President of the United States had been cordially honored, F. W. Lanchester proposed the Society of Automobile Engineers, and H. F. Donaldson replied. The Institution of Automobile Engineers was proposed by Howard E. Coffin, and replied to by Dr. H. S. Heleshaw. "Our Guests" was proposed by T. E. Browne, and replied to by Edward B. Ellington and Sir George Gibb.

Typical London November weather prevailed when, at 11 o'clock on Sunday morning, about 20 Ford cars called at the headquarters to carry the entire party to Brooklands motordrome, about 20 miles out of town. The showers, however, were unable to damp the spirits of the party, and even the arresting of C. H. Foster, president and general manager of the Gabriel Horn Company, and a couple of the Ford drivers for exceeding the speed limit only served to add interest to the run.

Lunch was taken at The Hut, Wisley, a typical English hostelry on the road from London to Portsmouth, and the run was continued to the track, where a couple of hours were spent in racing over the cement surfaced speedway, climbing the 25 per cent. test hill, and examining the unique timing apparatus.

After six days in London practically the entire party moved northward to Coventry, a town which may very accurately be described as the Detroit of Great Britain, for it is here that about three-quarters of the English factories are situated. A number of automobiles being in waiting, the visitors were taken direct to the Humber factory, and after presentation to the general manager, H. G. Burford, were shown through the works. Originally devoted to bicycle construction, the Humber factory now produces automobiles, motorcycles and bicycles, the number of cars produced being about 2,000 per year, and the number of motor-bicycles 4,000 to 5,000 a year. A staff of 3,000 men is employed.



The stop for lunch at the Hut on the way to Brooklands.



Leaving the Humber factory, Coventry

## Saw on British Trip

The high standard of factory management, and the comparative youthfulness of the heads of important departments came as a surprise to some of the members of the party, who had expected to find other conditions. The prodigality of labor, compared with American methods, was noted, but was readily understood in view of the lower rates of wages paid. Among the features which attracted attention were the water brake for engine testing, and the use of a chain for driving the camshaft of the Humber motors. It was explained that the practice was to use a Coventry chain which had been run in on a jig for a fortnight without a stop, this being equal to road service of 10,000 miles. There would be a stretch of one-sixteenth of an inch on the length of the chain, but after this treatment no further stretch would take place, and no provision for taking up slack was provided on the motor. The Humber company entertained the engineers at lunch at the King's Head Hotel, under the chairmanship of D. F. Basden, president of the company, supported by Ballin Hinde, vice-president, and H. G. Burford, general manager. On the afternoon of the same day a visit was made to the works of Alfred Herbert, Ltd., one of the largest machine-tool makers in England.

The greater portion of the second day's visit to Coventry was spent at the Daimler Company's factory, the first one in Britain to be devoted exclusively to automobile construction, and at present the largest in England, the output being about 3,200 cars a year, and the entire staff numbering nearly 5,000 men. As is generally known, the Daimler Company of Coventry produces Knight motors to the entire exclusion of the poppet-valve type, the motors being built for their own cars and for several other firms holding the Knight license but not yet in a position to produce sleeve-valve motors. These large Diesel motors used for generating current attracted particular attention, as did also a gasoline-electric bus with two Knight motors, one on each side of the frame, with separate drive to each rear wheel.

For the second time the visitors were entertained at luncheon, the hosts on this occasion being the Daimler Company, represented by Percy Martin, vice-president, in the chair, supported by E. M. C. Instone, the business manager, and by Charles Y. Knight. In replying to the toast of "The Guests," proposed by Mr.

Knight, H. F. Donaldson echoed the sentiments of the whole party when he declared that they had considered London the apex of cordiality, for they had been received as cousins; but at Coventry they had been welcomed as brothers. A busy afternoon was occupied in visiting the wire wheel factory of the Rudge-Whitworth Company, where sets of wire and wood wheels were tested to destruction; examining the plant of the Coventry Chain Company, the makers of most of the chains now used for driving camshafts, and a run through Warwick, Kenilworth and Stratford-on-Avon in Daimler cars supplied by Mr. Knight.

Birmingham tried to outdo Coventry in the matter of hospitality. When the members of the Society of Automobile Engineers arrived at the works of the Wolseley Tool & Motor Company they found the Stars and Stripes flying side by side with the Union Jack and an open house and a glad welcome within.

Very close attention was paid by the visitors to the cutting of worm gears for final drive, the Wolseley company using the worm for its 12 and 16-horsepower models, and bevel gears for all the larger types. It was declared that the efficiency was equal on the two types, and that they had been able to make the bevel just as silent in action as the worm; this was due in a large measure to the method of hardening each tooth of the crown-bevel wheel separately under an oxy-acetylene flame. Each wheel is mounted in a bath so that it can be revolved, and the tooth just on the surface of the water is operated upon with the flame. It is declared that by this method all possibility of distortion of the bevel wheel is removed. The new case-hardening rooms with the pyrometer going direct to the laboratory, thus removing all responsibility for the temperature from the workmen, were examined with interest.

The bench tests of the motors are carried out in the usual way and as soon as a motor is passed as satisfactory it is torn down, examined and washed piece by piece under a powerful jet of kerosene. Each chassis is taken on the road by three different testers, all of whom must fill in a very detailed report covering practically every portion of the mechanism, and stating the road and weather conditions which obtained during the tests.

When the car has been declared satisfactory it is again pulled down, examined for traces of wear, and finally assembled. Although building in series, the factory pays close attention to individual requirements in the matter of the body and fittings.

After the visit to the factory the officials of the Wolseley Company entertained the visitors at luncheon at the Grand Hotel, Birmingham, the president on the occasion being Mr. MacCormack, general manager of the company, supported by Max R. Lawrence, works manager, and Mr. Royce.



Legros of I. A. E. explains things to Coffin

Group of motorists watching car climb test hill at Brooklands



# First American Road Congress Meets

**R**ICHMOND, Nov. 23—The 4-day convention of the first American road congress of the recently organized American Association for Highway Improvement, ended in this city this afternoon with the election of officers for the coming year. The sessions proved to be of interest from start to finish. Over 500 delegates from all of the states and territories of the Union attended and the discussions following the different addresses proved how much attention is being devoted at present to the good roads movement. The two opening days of the convention were given over to the road builders, many of the leading civil engineers of the country being present. In fact, more of these attended than at any previous road congress. A novel feature of the convention, and one which appealed especially to motor car owners, was the third day, which was known as road users' day. The program for it was handled by the Touring Club of America, and it had gathered together several of the leading legal lights in the country who have to do with automobile legislation, as well as not a few of the leading car manufacturers. Among the legal representatives were Edward Lazansky, Secretary of State, New York; Matthew S. Rogers, Secretary of State, Connecticut; and Highway Commissioner Colonel William D. Sohier, of Massachusetts. In the automobile manufacturing field were Colonel Clifton, president of the Automobile Board of Trade, and Hugh Chalmers. Major Richard Sylvester, president of the International Police Association, spoke on the regulation of traffic in cities. Other speakers were Sidney S. Gorham, Chicago, and Preston Belvin, president of the Virginia Automobile Association.

Special interest attached to the addresses of Colonel Sohier and also of Secretary Lazansky, both of whom presented statistics to show the present status of the motor car in their respective states and sections. In the year 1901 there were 954 cars registered in the Empire state whereas this year there were upwards of 85,000 cars registered. Nearly 34,000 chauffeurs have been registered.

Basing his calculations on these figures the speaker showed that to-day there is approximately \$85,000,000 invested in cars in the state and that a little over \$42,000,000 is expended annually in maintaining these.

In speaking on the number of cars owned throughout the country, Secretary Lazansky based his figures on the data obtained from the government figures which showed up to the present, a registration in thirty-five states of approximately 517,000 cars, of 174,000 registered chauffeurs and total receipts from registrations of \$3,746,938.

Colonel Sohier spent most of his time on showing the number of cars in use in Massachusetts as compared with horse vehicles and also proving the point that motor vehicles cause many fewer accidents per mile traveled than trolley cars. He brought out the amazing fact that horses are decreasing in city use in the big cities but gaining in use in the country, but when the totals are looked into it is found that the horse is on the decline so far as numbers in use in Massachusetts are concerned.

Colonel Clifton was reminiscent of the early days of motoring to show the conditions of roads when the New York-Buffalo and New York-Pittsburgh tours took place. He used this as a basis for showing that since the inception of the automobile industry the car maker has always taken the attitude of co-operation with the different good roads organizations. He showed that contests have done much to stimulate the good roads cause as well as the actual building of good roads.

Hugh Chalmers showed how that the automobile is not the only industry that is benefited by good roads but cited how it costs 23 cents a mile to handle a ton of goods on the American

roads as compared with less than 10 cents a mile on European roads. On some of the English roads entering London where motor trucks are used, the cost is less than 4 cents a mile. If the freight bill of this country could be cut in half it would mean a saving to the people of \$250,000,000 a year. In speaking of the cost of building modern roads in different sections of the country, he brought out the fact that in North and South Carolina macadam roads can be built for \$1,800 per mile; and that in nine states in the South the average cost of macadam roads approximate \$4,000 per mile. In southern Ohio bituminous macadam roads cost \$7,000 per mile; in Massachusetts the average macadam road costs \$8,000 per mile and in New York State the new roads are costing \$9,000 per mile. Ohio has some brick roads which cost from \$10,000 to \$14,000 per mile.

Following is an extract of Colonel Sohier's address on motoring conditions in the State of Massachusetts:

It may be well to consider what the character of the travel that is using our highways at particular points is, and how that travel is likely to develop in the future. In 1909 the Massachusetts highway commission made a traffic census of the vehicles using state highways. The passing vehicles were actually counted at 240 stations upon our state highways scattered throughout the state for 14 hours a day, 7 days in August and 7 days in October. They were classified into heavy and light horse-drawn vehicles, and the motor vehicles were divided into touring cars and runabouts. At that time the motor truck had not appeared. I insert a table which gives a summary of this traffic census.

The actual count showed that on some of the roads the motor vehicles, even at that time, constituted 90 per cent. of the traffic, and in several instances over 1,100 cars a day passed a given point. A census was taken at certain places in the parkways near Boston, and this count showed over 60 per cent. automobile travel and over 3,000 automobiles a day. Even at that time, therefore, on many of our highways, especially on the main routes, it was found that the motor vehicle constituted more than one-half of the travel.

### Average Daily Traffic—All Stations

	August Census	October Census
Horse-drawn:		
Light .....	19,622	16,456
Heavy .....	17,969	17,967
Total .....	37,591	34,423
Automobiles:		
Runabouts .....	5,922	3,995
Touring cars .....	21,387	14,514
Total .....	27,309	18,509
All kinds .....	64,900	52,952
Per cent. horse-drawn .....	58%	65%
Per cent. automobile .....	42%	35%
Average per station:		
Horse-drawn:		
Light .....	83	69
Heavy .....	76	75
Total .....	159	144
Automobiles .....	115	77
All kinds .....	274	221

\*In August 237 stations; in October 240 stations.

### Accidents on Our Streets and Highways

Automobile accidents throughout the country were receiving an undue share of notoriety. They were given scare headlines in the papers, partly because this is a new means of locomotion and partly because of the prominence of the people occupying the automobiles. I think this matter will be of some interest to you. Please remember that of all the automobile accidents which we were able to hear of and record, 960 of the total of 1,182 accidents in 1910 occurred in city streets. In other words, four accidents occurred in city streets to every one in the country.

During the year ending November 30, 1910, according to the report of the police commissioner, the following number of people were killed and injured in the streets, parks and squares of Boston:

Total number of people killed.....	94
Total number of people injured.....	2,025
Due to traffic:	
Deaths .....	50
Injuries .....	1,022

In other words, only one-half of the deaths and only one-half of the injuries were due to traffic. Very few of these injuries were due to fire engines, bicycles or trains, so these figures are omitted.

### Deaths and Injuries by Traffic

Total number of deaths.....	50
Due to horse-drawn vehicles.....	15, or 30%
Due to trolley cars .....	22, or 44%
Due to automobiles .....	13, or 26%
Total number of injuries.....	1,022
Due to trolley cars.....	383, or 37½%
Due to horse-drawn vehicles.....	359, or 35%
Due to automobiles.....	280, or 27½%

In this same period of time various other accidents were due to other causes, by far the largest of which was falls resulting in twenty-three deaths and 777 injuries.

In other words, there were nearly twice as many deaths and nearly twice as many injuries in the streets of Boston which were due to people falling in the street and being injured than were due to motor vehicles. It is a little hard to make comparisons, because the numbers of electric cars, horse-drawn vehicles and automobiles is not really a fair criterion. The mileage should also be taken into account.

**Increase in Motor Vehicles**

To make a comparison today, we should consider the growth of the number of automobiles using our streets:

- In 1903, 3,241 automobiles were registered in Massachusetts.
- In 1909, 23,902 automobiles were registered in Massachusetts.
- In 1910, 31,347 automobiles were registered in Massachusetts.
- In 1911, 38,677 automobiles were registered in Massachusetts.

At least 5,000 dealers' cars are registered as well. Since our traffic statistics were taken the number of automobiles registered in the State has increased over 60%.

**Decrease in Horses**

In Massachusetts, in 1909, about 169,000 horses were assessed, and in 1910 about 165,000. In this one year the number of horses assessed had decreased 4,000, and the number of automobiles registered had increased 7,400. Undoubtedly, there is more of a change this year.

I merely put in these figures as preliminary to further consideration of to what extent the automobile is responsible for the accidents which occur on our highways. It is evident today that they constitute fully 50% of all the vehicles that are passing over our highways.

**Trolley Cars and Motor Vehicles**

It is interesting to compare upon this basis of mileage the accidents occasioned by trolley cars and the accidents occasioned by automobiles. The trolley car mileage and accidents are both official figures taken from the railroad-commissioners' report:

Trolley Cars:—Miles Traveled.....	87,712,572
<b>Fatal Accidents:</b>	
Passengers and employees .....	28
Outsiders .....	78
<b>Total .....</b>	<b>106</b>
<b>Injuries:</b>	
Passengers and employees.....	5,273
Outsiders .....	1,917
<b>Total .....</b>	<b>7,190</b>
<b>MOTOR VEHICLES:—Miles Traveled.....</b>	<b>185,806,000</b>
<b>Fatal Accidents:</b>	
In Motor Vehicles.....	25
Outsiders .....	52
<b>Total .....</b>	<b>77</b>
<b>Injuries:</b>	
In Motor Vehicles .....	378
Outsiders .....	585
<b>Total .....</b>	<b>963</b>

Assuming that the above mileage for motor vehicles is correct, we should have the following results:

<b>Number of Miles Traveled by Trolley Cars and Motor Vehicles to Each Ensuing Accident</b>		
	Trolleys	Motor Vehicles
Miles per accident to anyone, including fatal cases	12,053	178,660
Miles traveled per fatal accident.....	827,477	2,413,065
Miles traveled per injury.....	12,199	192,945
<b>Accidents to Persons Who Are not Employees or Occupants of Cars:</b>		
Miles traveled per accident.....	44,389	291,689
Miles traveled per fatal accident.....	1,124,520	3,573,192
Miles traveled per injury.....	45,755	317,617
<b>Accidents to Employees and Occupants of Cars:</b>		
Miles traveled per accident.....	16,546	461,057
Miles traveled per fatal accident.....	3,132,449	7,432,240
Miles traveled per injury.....	16,634	491,577

**Automobile Legislation in Massachusetts**

No person can operate an unregistered motor vehicle and no person can operate a motor vehicle without having received a license from the Massachusetts highway commission.

The commission may revoke a license, after due hearing, for any cause it may deem sufficient; and it may suspend a license, without a hearing, whenever it has reason to believe that the holder thereof is an improper or incompetent person to operate motor vehicles or is operating improperly or so as to endanger the public; and the license shall not be reissued unless the commission, upon examination or investigation, or after a hearing determines that the person should again be permitted to operate.

In 1908 the commission was authorized by law to investigate automobile accidents. Whenever a death results from any such accident, the commission shall suspend forthwith the license of the operator of the motor vehicle involved, and it shall revoke said license unless after an investigation or hearing, it determines that the accident occurred without serious fault upon the part of the operator.

The commission shall revoke the license of a person three times convicted of overspeeding in any one calendar year; and no new license may be issued to such a person until after the expiration of a period of 30 days from the date of the third conviction. Acts of 1909. The commission shall revoke the license of any person convicted of operating a motor vehicle recklessly, or while under the influence of intoxicating liquor, or so as to endanger the lives or the safety of the public; or upon a bet, wager, or race; or for the purpose of making a record; or of going away without stopping and making himself known after causing injury to person or property; or of using a motor vehicle without authority; and no new license shall be issued to any such person before the expiration of a period of 60 days from the date of conviction nor thereafter except in the discretion of the commission.

The commission, by law, has the right to appoint investigators and examiners. It has appointed seven such investigators and examiners and they are among the most competent men of their class to be found anywhere. These examiners examine every chauffeur before he receives a license. He is required to pass a written examination and also to pass a severe operating test on the road.

Examinations held in 1910.....	5,433
Number of persons examined.....	4,138
Number of persons receiving licenses.....	3,701
Number of persons failed on first examination.....	1,268
Number of persons refused a license after several examinations .....	437

In other words, over 10% of all the persons examined failed to receive a license, and nearly 25% of all the persons failed to pass upon the first examination.

**Investigation of Accidents**

During the year 1910 its investigators made investigation and reported 429 accidents. In that year 283 licenses or registration certificates were revoked or suspended. The causes of these revocations and suspensions were shown in the following table:

Reckless operation .....	50
Operating while under the influence of intoxicating liquor	22
Accidents resulting in death .....	57
Improper operation .....	88
Refusing or neglecting to stop after accident.....	9
Three overspeeding convictions.....	8
Operating automobiles without owner's permission.....	23
Other offenses .....	26
<b>Total .....</b>	<b>283</b>

**Motor Vehicle Accidents**

The following table of accidents which occurred in Massachusetts in 1909 and 1910 may be of interest:

	1909	1910
Total number killed .....	54	77
Total number injured .....	989	963
Total number of accidents.....	1,130	1,182
Total number of accidents in daytime.....	826	867
Total number of accidents after dark.....	304	315
Total number of accidents on country roads.....	314	222
Total number of accidents on city or town streets .....	816	960

In 10 months of the year 1911, there were 1,229 such accidents. In this connection, it must be remembered that in 1909 something under 24,000 automobiles were registered in Massachusetts and that in 1911 (allowing only five cars for each dealer) there were something over 42,000 automobiles registered. In other words, the number of automobiles using our highways has increased in that two years something over 60%. The number of accidents has only increased about 10%.

**Causes of Accidents**

It may be interesting to see what, in the opinion of the commission, after careful investigation and report upon all the evidence, was the cause of some of the more serious of these accidents. I have made an abstract of a few of the more serious accidents for 10 months of this year—from December 1, 1910, to October 1, 1911, as shown by the following table:

Total number of accidents investigated and acted upon .....	278
Operator without fault .....	110
Other party to accident more to blame than operator, but operator not blameless .....	20
Operator more to blame than other party to accident, but latter at fault also .....	24
Operator entirely to blame.....	114
Both operators equally to blame.....	10

You will note that after a full investigation, involving a statement taken from all of the witnesses and a careful report from our investigator, and consideration by the commission, in nearly 40% of all of these accidents the operator was not to blame.

As a result of the discussion, the committee on resolutions selected by the Touring Club of America recommended and secured the adoption of the Road Congress of the following suggestions for traffic regulation:

WHEREAS, the safety of the public is of primary importance, and the driving of vehicles at night is attended by dangers which should be reduced to a minimum;

Now, therefore, Be it further Resolved, That it is the sense of this Congress that from sunset to sunrise, all vehicles should carry at least one lighted lamp of sufficient candle power to be visible at a distance of 200 feet, so placed as to be seen from the front and left side, and a red light visible in the reverse direction, and

Be it further Resolved, That the use in cities and villages of non-dazzling headlights on all vehicles should be required by law, wherever the streets are adequately lighted, and

WHEREAS, the highways within the confines of the cities, towns and villages, as well as in the open country, are dedicated to the public use.

Now, therefore, be it Resolved, That all users of said highways should have due regard for the rights of other users, the pedestrian for the rights of horse-drawn vehicles, the drivers of horse-drawn vehicles for the rights of the drivers of motor vehicles, the drivers of motor vehicles for the rights of cyclists, the cyclists for the rights of equestrians, and one and all for the rights each of the others, and

Be it further Resolved, That the use of the muffler cut-out in thickly settled sections and in cities should be discontinued, and

Be it further Resolved, That the unnecessary use of warning signals should be avoided, and that an adequate warning signal should produce an abrupt sound, sufficiently loud to be heard under all conditions of traffic, and that its use except as a warning of danger should be prohibited by law, and

Be it further Resolved, That in cities, towns and villages, slow-moving vehicles should be required to drive close to the curb in order that the faster moving vehicles may pass in the center of the thoroughfare, and

Be it further Resolved, That in view of the fact that the motor vehicle is used for interstate communication, frequently passing through two or more states during a single day, uniform speed regulations should be adopted by all states, and local authorities, such as cities, towns and villages, should be prohibited from fixing local speed regulations, and

Be it further Resolved, That in view of the rapid development of commercial motor trucks for inter-city use, the public authorities charged with the duty of building and maintaining bridges should be required periodically to inspect all bridges under their jurisdiction and post conspicuously thereon the wheel load they are capable of sustaining, and

Be it further Resolved, That in view of the unprecedented growth of interstate and inter-city motor traffic for commercial purposes, a systematic and adequate placarding of roads by sign-boards, giving directions as to towns and distances should be required by law, and such laws strictly enforced.

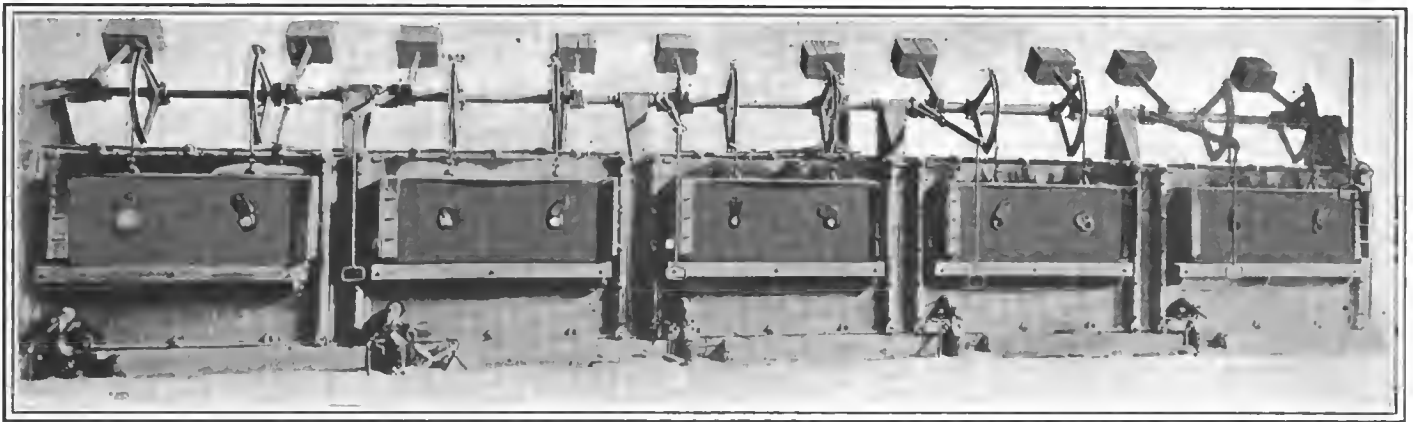

Fig. 1—View of the five new casehardening furnaces installed at Warner plant at Toledo

## Equipment for Heat Treatment

CASEHARDENING and special heat treatments enter so widely into the field of making automobile parts that the Warner Manufacturing Company, of Toledo, Ohio, which makes steering, transmission and differential gears, has found it necessary to install a large new plant for this purpose. The equipment of this plant comprises five casehardening furnaces Fig. 1 which are arranged in battery form, and two heat-treating furnaces, and it was designed by Walter Macleod & Co., of Cincinnati, Ohio. Included in the plant are also a steel fan pressure blower, which is directly connected to a motor, a rotary oil pump geared to the blower shaft, and a Taylor multiple indicating pyrometer outfit. Furthermore the equipment includes a 13,000-gallon oil tank, pipes and gauges, and a motor for determining the fuel consumption.

In order to get the maximum amount of work out of the furnaces with the least expense involved, it is necessary to have this equipment designed in the most effi-

cient fashion. All seven furnaces contained in this plant are made of high-class fire brick, encased in heavy sectional cast-iron ribbed plates which are held in their relative positions by means of bolting strips and tie rods. The combustion chamber, in each furnace, is located adjacent to the heating space and the construction of the former space is such as to permit of proper distribution of the gases carried to the heating-chamber arch, so that the charge is heated effectively, yet in a protected position. After heating the material the gases pass into flues in the walls.

Taking into account the tendency of hot gases to rise, the combustion chamber is so constructed as to permit the hot gases to fill it and then to escape, under a uniform pressure, through the ports to the heating chamber. The pockets leading thereto are fire-brick lined. The hearth is a solid foundation of common standard-shape fire brick. The fuel used being oil, an oil burner is stationed in front of the furnace parallel with the combustion cham-

ber, while an auxiliary air blast enters on the opposite end. This blast is controlled by a valve directly under the burner.

In the casehardening furnaces, the heating chambers are each 54 by 72 inches, while in the heat-treating furnaces Fig. 2 they are 32 by 40 inches. The casehardening furnaces have, at 1560 degrees Fahrenheit, a capacity of 190 sets of transmission gears per day of 24 hours. Average penetration of hardening is 1-32 inch.

The variation in temperature in a combustion chamber is not more than 30 degrees Fahrenheit.

Oil and air used for heating are supplied by a unit Fig. 3, composed of a No. 8 A. B. C. steel fan pressure blower which is directly connected to a 15-horsepower electric motor by a flanged coupling.

The oil pump is constructed for the so-called suction-return system and is fitted with check and relief valve, pressure gauge and all other necessary accessories. The pyrometer outfit used is the product of the Taylor Instrument Companies.

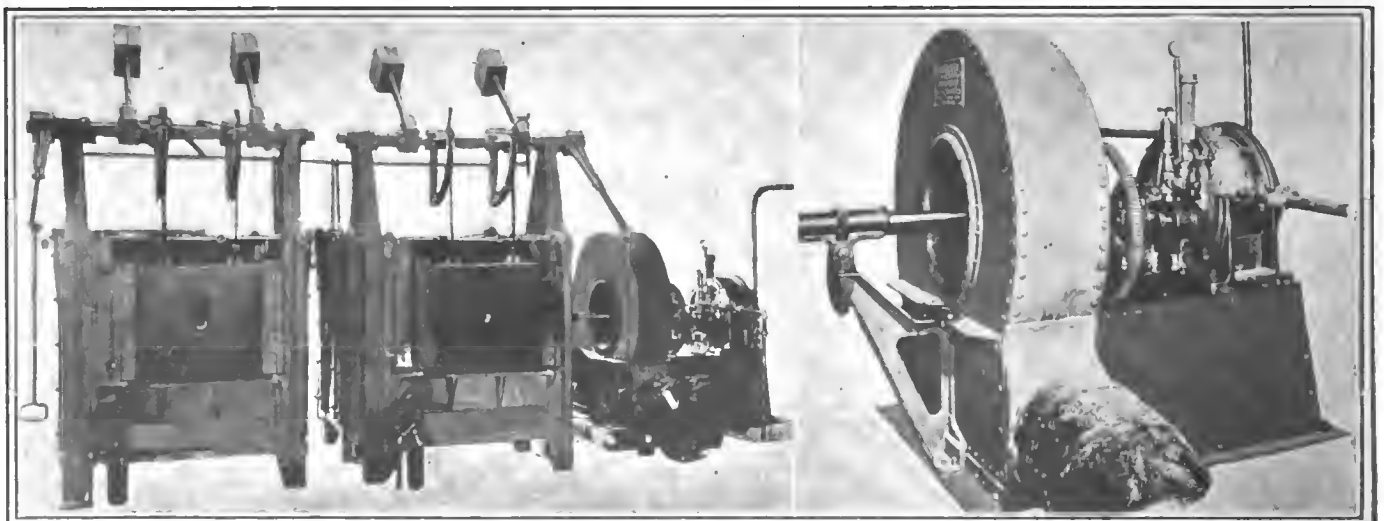

Fig. 2—Two heat-treating furnaces and motor operating them.

Fig. 3—Steel fan pressure blower and motor

## Service Buildings Open in New York

**T**HE F. B. Stearns Company, of New York City, has just opened extensive quarters for the accommodation of its patrons, whose cars are in a state to be repaired. The rapid growth of the concern's business was the cause of the old repair department at 227 West 57th street proving too small for the increasing need, so that the company had to go to the construction of more spacious premises.

The new service department, which in its entirety is devoted to the repair and overhauling of Stearns products, is located at 415 West 55th street. The building, which is shown in the accompanying illustration, is six stories high, these lofts, in addition to a basement, being equipped in a most up-to-date manner in order to take care of the work that comes in. The space is about 40 x 100 on each floor, making a total of about 30,000 square feet.

On the ground floor is stationed the office, and here too the cars make their way to the elevators lifting them to the higher floors. The entrance from the street is wide enough to permit the heaviest trucks to enter. The second floor contains the stock room, with a complete stock of Stearns repair parts. This department takes up almost half of the floor, while the other half is used for overhauling purposes. The next higher floor houses the machine shop and the automobiles, while such repairs are executed upon them as necessitate the proximity of the shop. The other floors are used for storing and assembling work, as well as for general tuning-up work.

When some weeks ago the finishing touch had hardly been put on the building, the

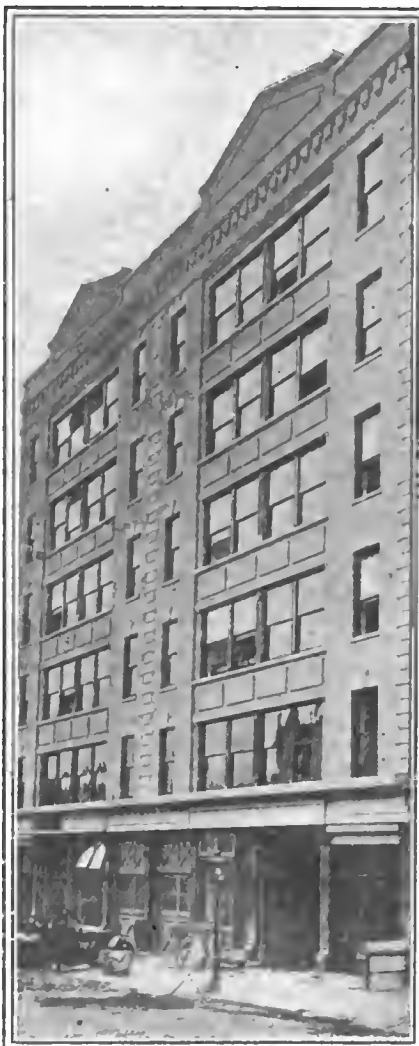

Beautiful new Stearns and Mitchell Buildings

workmen of the company were already busy on the various machines in the building. The building had been opened but for two days and already there were about two dozen automobiles there, expecting speedy treatment. A corner of the third floor is shown, with two cars being worked on and part of the machine shop in sight.

Automobile companies find this neighborhood a most suitable one to install their service departments in, and it may safely be predicted that within a short time many concerns will follow the example set by Stearns and others. This is foretold by the fact that the Mitchell corporation has opened a service building adjacent to the Stearns department, which is seen on the left of the upright illustration. The space occupied by the Mitchell works is about the same as that used by the Stearns people. The New York home of the Saurer trucks is situated at the right of the Stearns building.

At foot West 57th street, the White Company is just finishing its new service department. This is a ground-floor affair, with no upper stories, but it has almost as much total area as the Stearns place, being 100 by 240 feet large. Like the other building, the White place is constructed of reinforced concrete. The lighting system demands special comment, in that plenty of light is available at every place in the building. This is accomplished, not by a full-glass roof, but by placing the roof surface at two levels and connecting these by huge vertical windows permitting lots of light to enter the interior. The White building also serves only as a service department, and no garage work is done in it.

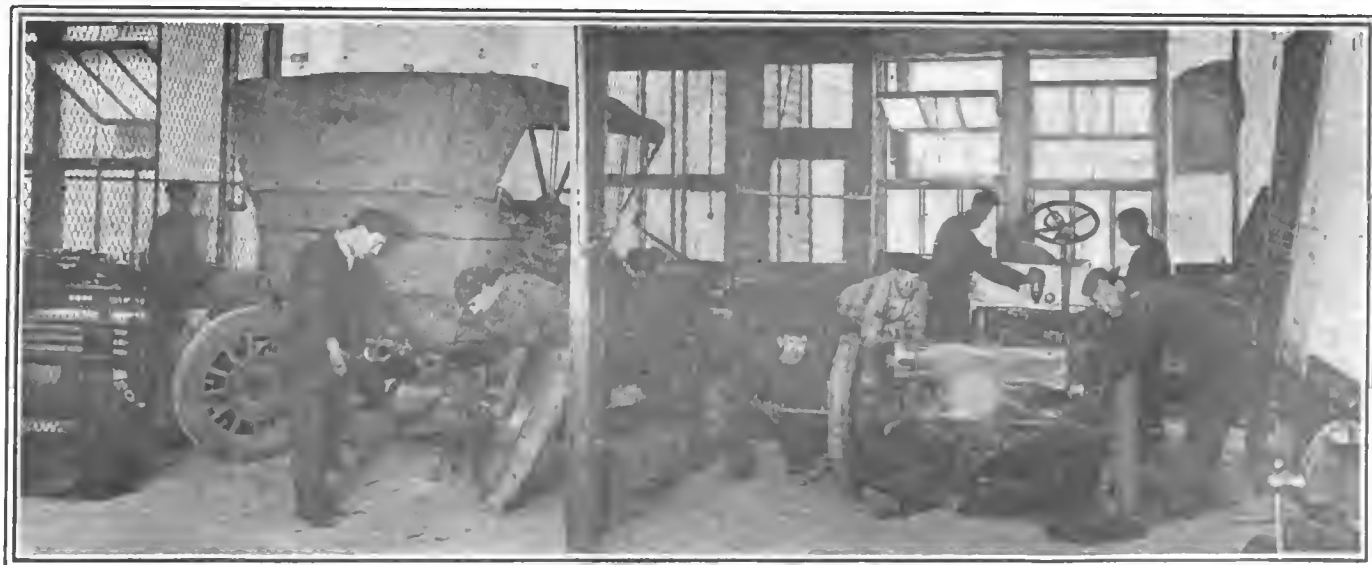

The interior of the Stearns repair shop is spacious and adequately lighted



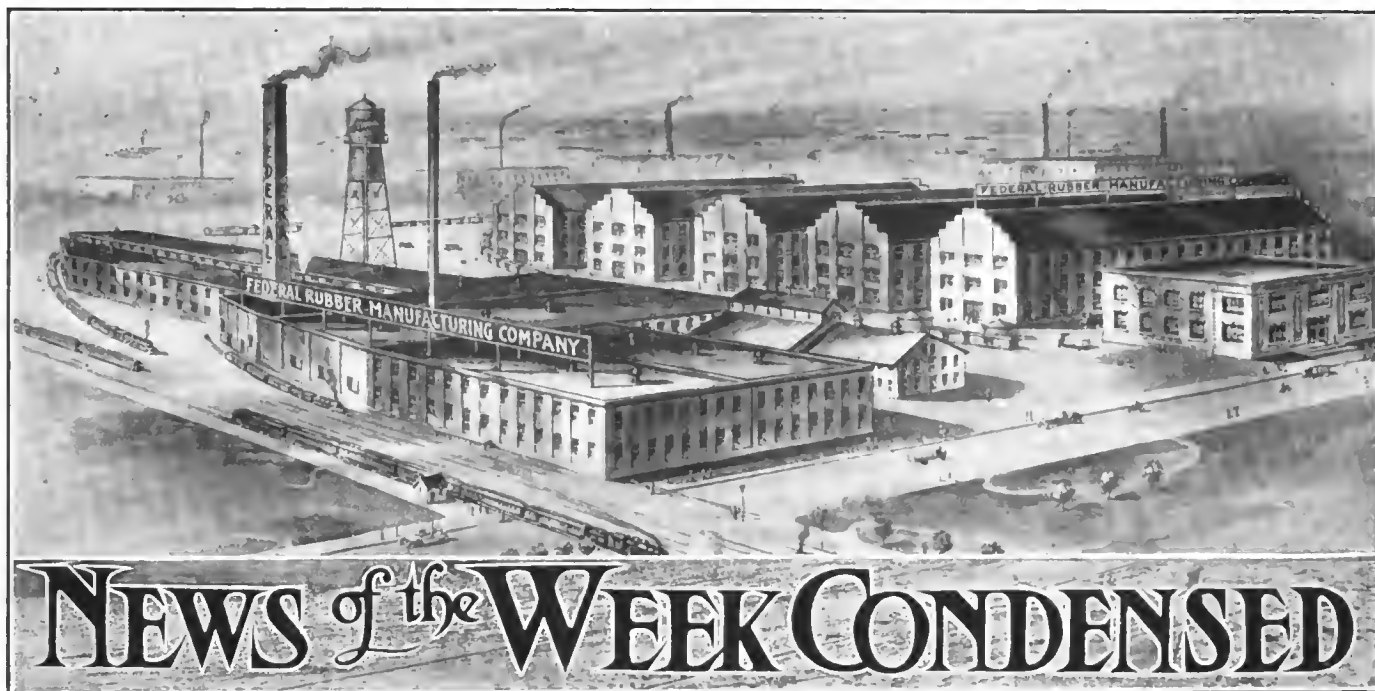

Bird's-eye view of the new plant of the Federal Rubber Manufacturing Company at Cudahy, Wis.

**CUDAHY, WIS.**—Since the announcement by the Federal Rubber Manufacturing Company last July of its acquisition of the plant formerly operated by the Federal Rubber Company in this city, and of its purpose to enlarge and remodel the property throughout, this work, in charge of the Westinghouse-Church-Kerr Company, has been rushed night and day. The Federal plant is located on a five-acre tract on the main line of the Chicago & Northwestern Railroad. It is provided with ample switching facilities for the economic handling of its raw material and for the distribution of its finished products.

**KIRBYVILLE, TEX.**—M. Singletary of this city is to open a garage and machine shop.

**SANFORD, ME.**—The Ford Auto Co. has taken the agency for the 1912 line of Pullman cars.

**LOWELL, MASS.**—Frank E. Harris has taken the agency for the Oldsmobile in this vicinity.

**TRENTON, N. J.**—Harry Stout, 12 and 14 East State street, has added the Pullman car to his line of 1912 models.

**SANDUSKY, O.**—The Sandusky Auto Parts & Motor Truck Co. has increased its capital stock from \$150,000 to \$500,000.

**NEW BRITAIN, CONN.**—T. W. Crowe has been awarded the contract for the garage to be erected by the New Britain Gas Light Co.

**MILWAUKEE, WIS.**—The Goodyear Rubber & Tire Co. has established a branch at 134-136 Oneida street. H. P. Ziegler is manager.

**PHILADELPHIA.**—Settlement was made recently by the Automobile Club of Philadel-

phia for a site for a two-story clubhouse and garage.

**MILWAUKEE, WIS.**—Edwin J. Groth, 1125 25th street, has been appointed distributor of the Crown positive safety lock for motor cars in this territory.

**HAMBURG, GERMANY.**—The Ford Motor Co. of Detroit, Mich., U.S.A., has opened a branch in this city. The European trade of the company continues to expand.

**SAN ANTONIO, TEX.**—The Taxicab Co. of this city has changed its name to the Transfer & Taxicab Co., and has increased its capital stock from \$15,000 to \$30,000.

**AKRON, O.**—M. H. Pletcher will handle the Pullman 1912 line in Summit county. Mr. Pletcher will also establish a number of Pullman agencies throughout the state.

**PITTSBURGH, PA.**—Plans have been completed for a two-story brick and reinforced concrete garage and sales building to be constructed in the East End for the White Co. of Cleveland, O.

**HARRISBURG, PA.**—According to statistics announced this week by the Pennsylvania state highway department over 44,000 licenses have been issued by the automobile license division up to the present time.

**GENEVA, N. Y.**—The ferry across Cayuga Lake has been discontinued for the season, making it necessary to use the Montezuma Swamp road via Free Bridge. The road is in passable but dangerous condition.

**PORT WASHINGTON, WIS.**—The Kraus & Grau Hardware Co. has been appointed Ozaukee county agent for the Cutting, Westcott, Herreshoff and National lines, which are represented in Wisconsin by the

Wisconsin Auto Sales Co., 114 Mason street, Milwaukee.

**WYOMING, ILL.**—E. H. Brown, Stark County agent for the Studebaker, E-M-F and Flanders cars, is planning extensive enlargements and improvements to his garage on Main street this winter. Mr. Brown has again contracted for the Studebaker lines for the coming season.

**DETROIT, MICH.**—R. E. Fair, manager of the Lion Motor Sales Co., has closed a contract with the Farmers' Handy Wagon Co. of Saginaw for 35 Lion 40s. The Saginaw concern has purchased the cars for the use of their salesmen, who will thus be able to cover their respective territory more thoroughly than by depending on trains and livery rigs.

**DETROIT, MICH.**—The Republic Rubber Co. of Michigan has been incorporated and will handle the full line of automobile and motor truck tires manufactured by the Republic Rubber Co. of Youngstown, O. The local salesroom and office will be located at No. 1001 Woodward avenue, with C. P. Foley, formerly with the local branch of the Firestone Tire & Rubber Co., in charge.

**FREEMONT, ILL.**—A. H. Kloeping & Co. have taken over the Bijou Garage on Douglass avenue and will handle the Studebaker lines in Stephenson County for 1912. While the main office of the new concern will be in Freeport, branches will be established in Orangeville, under the management of A. M. Snyder, at Rock City under the management of A. H. Kloeping, and the Freeport end will be handled by George Mitchell. Branches will also be established at German Valley and Pearl City.



CHETEK, WIS.—Harry E. Johnson has established a garage here.

RACINE, WIS.—The Racine Automobile & Motor Works will represent the Buick line in this territory.

AUGUSTA, WIS.—Julius Walthenpuhl has been appointed district agent for the Imperial and is now erecting a garage.

PORTLAND, ORE.—The Rose City Garage of Portland has taken the Oregon distribution of the Baker electric machines.

CINCINNATI, O.—The Eddy Auto Co. is erecting a \$10,000 one-story concrete and brick automobile garage on May street.

SYRACUSE, N. Y.—The James Auto Co. will handle the Central New York territory for the Hudson Motor Car Co. of Detroit.

WAUSAU, WIS.—The L. H. Hall Co., agent for the Chalmers line for several years, has become exclusive agent for the KisselKar.

MONDOVI, WIS.—R. P. Goddard, Jr., has been appointed local agent for the Jackson, and has completed work on a new garage building.

LOUISVILLE, KY.—The Louisville Automobile Co., local agent for the Hupmobile, has acquired the agency for the Van Dyke trucks in this territory.

KEWASKUM, WIS.—The John W. Schaefer & Sons Co. is erecting a new garage here. The company will represent the Overland line in several counties.

SEATTLE, WASH.—Fred M. Powell has become identified with the Hugh A. Baird Co. of this city in the capacity of sales manager. The Baird Co. handles the Reo, Franklin and Apperson cars.

CINCINNATI, O.—C. H. Linson, manager of the Motor Car Supply Co. has severed his connection with that company and will go to Minneapolis, Minn., to act as branch agent for the Republic Tire Co.

SYRACUSE, N. Y.—The Velie Motor Vehicle Co., through the Kerr-Doane Motor Co. of this city, has established the following agencies for Velie cars: Norwich, Binghamton, Hornell, Elmira, and Ithaca.

MOBILE, ALA.—The Sowell Auto Co. will conduct the garage formerly operated by the McMain Motor Car Co. The Sowell Co. is composed of Walter Sowell and D. C. Sowell, formerly of Wallace, Ala., and Richland, Miss.

DETROIT, MICH.—A. J. Rousseau, who has been identified with the General Motors Co. for some time, has been appointed sales manager in charge of the western district for the Imperial Automobile Co. of Jackson, Mich.

LOUISVILLE, KY.—The business of the Ford Motor Co. of Detroit has been increasing so rapidly in Kentucky through their Louisville agent, the Banks Motor Car Co., that the factory established a permanent branch here this week.

NEW YORK CITY—George Armstrong, representing Carlos Armstrong, E. Hijos, Playa-Ponce, Porto Rico, on a recent trip to this city, arranged with the Colt-Stratton Co., Cole eastern distributor, to handle the Cole car in Porto Rico.

WHITE SALMON, WASH.—A new bridge is to be built over the river near here to accommodate the heavy loads which will be hauled by 5-ton automobile trucks used in transporting material for the construction of the new concrete dam.

NEW YORK CITY.—The Motor Car Equipment Co. is opening an uptown branch in addition to its main headquarters at 55 Warren street. The branch is located at 238-40 West 56th street, and will be ready for business about the December 10.

NEW YORK CITY.—The American Express Co. has a fleet of fifteen Packard 3-ton trucks in service in this city. After several years of experiment the company has found that the automobiles are cheaper and more efficient than horses in delivery work.

OMAHA, NEB.—S. A. Zapp and J. F. Lohrmann of Fremont have contracted with the Racine Sauley Co. to handle the Nyberg and Columbus cars in their territory. The Casey Auto Co. of Casey, Ia., will also handle the Nyberg cars.

SYRACUSE, N. Y.—F. R. Bump, who was formerly general sales manager of the H.

H. Franklin Mfg. Co. of this city has become assistant general manager of the R. C. Hupp organization. Mr. Bump has recently been with the Universal Motor Truck Co.

TOLEDO, O.—A new concern has been organized in Toledo to be known as the Ignition Starter Co. It has quarters in the Nicholas building. H. A. Cavanaugh and J. M. Ewing are the promoters of the business. They will equip cars with the Disco self-starter.

KENOSHA, WIS.—Richard H. Welles is at the head of the company which intends to provide the city of Kenosha with motor bus service. Mr. Welles states that the service will be inaugurated about December 1. The service will extend over the entire city, along regular routes, and will be operated winter and summer.

MILWAUKEE, WIS.—Recent agency appointments by the Hickman-Lauson-Diener Co., Milwaukee, state agent for the Ford, include: Marathon Motor Car Co., Wausau; Arthur Voss, Mukwanago; G. H. Hafemeister, Watertown; August Prange, Sheboygan; F. C. Behlendorf, Oshkosh; T. W. Twining, Gays Mills; John Hieltenthal, Lyons.

CINCINNATI, O.—Ira D. Cooper, formerly with the Morgan & Wright Tire Co., has left that organization and formed the Cooper Rubber Co., with the aim of distributing tires throughout Ohio, Indiana, Kentucky, and West Virginia. The new company will also handle its own line of bicycle, buggy, vehicle and solid motor tires. J. R. Burgamy, late of the Coughlin & Davis Co., has associated himself with the new firm.

INDIANAPOLIS, IND.—George Lehnert has been appointed receiver for the Star Motor Car Co. of this city by Judge Collier of the Superior Court. Action asking the appointment of a receiver was brought by Theodore M. Weiss, a stockholder, who alleges the concern is insolvent. The company was organized and incorporated in November, 1909, for the purpose of manufacturing motor cars but has never built but one car. Offices have been maintained in the Lemcke building.



Packard 3-ton trucks in the service of the American Express Company in New York City



President G. A. Matthews, of the Jackson Automobile Co., in his new coupé

HAGERSTOWN, MD.—R. Bruce Carson has taken the local agency for the Cole car.

KEWANEE, ILL.—The Kewanee Garage has been appointed agent for the Cole car.

FOND DU LAC, WIS.—The Auto Tire & Repair Co. has been appointed agent for the Rambler line.

MOSCOW, IA.—The Moscow Automobile Co. has been organized here to distribute the Cole car in this vicinity.

SAN FRANCISCO, CAL.—F. W. Burgers, formerly connected with the Phoenix Rubber Co., will hereafter handle the Batavia tire in this territory.

MILWAUKEE, WIS.—Bonow Bros. have taken over the Boulevard Garage at 266-268-270 Twenty-sixth street and will handle the Nyberg line of cars in Milwaukee county.

PORTLAND, ORE.—Showing the rapid increase in the number of automobiles now in Oregon, the total number of automobiles in this state in July, 1909, was 2100. Now there are over 6500.

RACINE, WIS.—Amended articles of the Mitchell-Lewis Motor Co. were filed with the register of deeds recently. Amendments provide for sixteen directors instead of ten as heretofore.

SYRACUSE, N. Y.—Representatives of the Knox, Rambler, White and Premier automobiles, which now have no agencies in the city, are now here, and it is stated that agencies will be established in a few days.

DETROIT, MICH.—The Detroit Public Library has established a branch at the factory of the Packard Motor Car Co. This step was taken in consideration of the fact that more than 7,000 persons are employed there.

JACKSON, MICH.—The Jackson Automobile Company has brought out a new model. It is a 40-horsepower coupé with 118-inch wheelbase and 34-inch wheels. The car,

which is electrically lighted throughout, has the steering wheel on the left and the control levers in the center.

MOLINE, ILL.—The Midland Motor Co. of this city, manufacturers of the Midland car, recently appointed the following new agents: Lewis Sales Co., 3950 Olive street, St. Louis, Mo.; Carrigan Bros., 1006 Olive street, Los Angeles, Cal.; Wm. Easton & Son, Austin, Nev.; Farmers' Exchange & Implement Co., Price, Utah.

GALESBURG, ILL.—Callender & Petrie will handle the Rambler line in this vicinity, with headquarters in Galesburg and a sub-branch in Ophiem. A new garage and salesroom is now being fitted up for them on Prairie street, which will be modern in every respect and ready for occupancy in a short time.

✓ SYRACUSE, N. Y.—The following have been recently appointed agents for the Franklin car: Woodhouse-Lough Co., Plainfield, N. J.; W. A. Worley, Jacksonville, Fla.; C. G. Meyer & Son, Tiffin, Ohio; Fruit-Ohl Co., Sharon, Pa.; Barber & Hunter, North Adams, Mass., and H. B. Sproul & Co., Staunton, Va.

✓ SYRACUSE, N. Y.—Julian Brown, son of the prominent manufacturer, A. T. Brown, of this city, announces that he will soon erect a factory for manufacturing the gas engine recently invented by him and which is attracting a great deal of attention in the trade. Mr. Brown will have plenty of financial backing. The factory site is not yet selected.

NEW YORK CITY.—In referring to the increase of the capital stock of the Thomas Motor Cab Co., of Buffalo, N. Y., from \$50,000 to \$100,000 in our issue of November 16 an unfortunate typographical error made it appear that the company in question was the Thomas Motor Car Co. of that city. As is well known, the capital of this company is \$2,400,000.

BOSTON, MASS.—The Franklin Co. has decided to give up its branch in Boston and hereafter it will be conducted as an agency. O. A. Lawton, who for some time has been manager of the branch, has decided to take the Franklin on as an agency proposition, and for the present he will have his salesrooms at 31 Irvington street. He has the New England territory.

MARINETTE, WIS.—The United Car & Sales Co. has been organized here by Myron Churchill and Harold Scott, to do a general agency and garage business at 1351 Main street. The concern will represent the Buick and Kissel-Kar lines. Alex Nordquist will be in charge of the garage and shops. Messrs. Churchill and Scott recently established the Marinette School of Motoring here.

DETROIT, MICH.—A. F. Mais, recently vice-president and chief engineer of the Mais Motor Truck Co. of Indianapolis, has resigned as chief engineer of the Mais company and accepted a position as consulting engineer for the Studebaker Corporation, E-M-F company. The old Ford plant located near the E-M-F factory in Detroit has been absorbed by the Studebaker corporation and converted into an experimental department. Mais is in charge of this department, which is known as plant No. 10. His office as vice-president of the Mais Motor Truck Co. is still retained together with his interest in the concern.

MILWAUKEE, WIS.—Efforts are being made by garage-keepers in Wisconsin to arrive at a uniform scale of rates for storage, washing and polishing. The accepted schedule is as follows: Two to five-passenger cars: storage, 50 cents; per month, \$15.00; washing, \$1.00; polishing, 50 cents. Seven-passenger cars: storage per day, 75 cents; per month, \$20.00; washing, \$1.50; polishing, 50 cents. Limousines: storage per day, 75 cents; per month, \$20.00; washing, \$2.00; polishing, 50 cents; use of wash-rack, \$1.00. Electric pleasure cars, per day, \$1.50; per month, including washing, polishing and charging, \$32.50. A uniform scale of prices for gas and oils is also to be made.

GALESBURG, ILL.—Hobbie & Martin, who for the past three years have been associated in the general garage business and as territory distributors for the Buick line for the surrounding counties, have dissolved partnership. The Buick line will be carried by W. C. Hobbie, who will have practically the same territory, while W. P. Martin, as manager and owner, will retain the garage located on Seminary avenue. Mr. Hobbie will open a salesroom in the business district with a small garage in connection. George Sperry, who has been with Mr. Hobbie for the past two years, will become his partner, and will take up the sale of Buick cars in Knox, Henry, Warren, and Mercer counties.

**YORK, PA.**—The Townsend Auto Co. of Easton, Md., has taken the agency for the 1912 line of Pullman cars.

**SÃO PAULO, BRAZIL.**—S. Kremer So-brinho has become the agent for the Pullman cars in this country.

**AKRON, O.**—The Cuyahoga Realty Co. will erect a \$17,000 garage and storage room at 41-45 North High street.

**WOODBINE, IA.**—F. C. McCann has secured the agency for the Nyberg car from the Racine-Sattley company of Omaha.

**DULUTH, MINN.**—W. J. Gorgon is now associated with the Interstate Automobile Co. as a member of the sales force.

**BALTIMORE, MD.**—James M. Easter is having plans prepared for a garage which he intends to erect at 2100 Eutaw Place.

**JACKSONVILLE, FLA.**—W. C. Thomas, of the Jacksonville Regal Motor Agency, has secured the agency for Florida for the Haynes car.

**GLOUCESTER, MASS.**—Perkins & Corliss, the local garage owners, have recently taken the agency for the Ford in this city, Manchester, Essex and Rockport.

**NEW YORK CITY.**—The American Rim Co. has taken quarters at 250 West Fifty-fourth street, where it will handle the Lambert demountable and quick detachable rim.

**CHICAGO, ILL.**—N. Lazarnick, of New York City, the pioneer automobile photographer, has opened a branch office and studio at 509 South Dearborn street, in this city.

**WALTHAM, MASS.**—The Motors Specialties Company of this city has discontinued its Boston office and has removed it to the factory where all departments will be under one roof.

**BOSTON, MASS.**—Hugh Miller has been made resident manager of the Aristos Co., distributors of the Disc-Self-Starter, with offices and salesrooms at 1002 Boylston street.

**LOS ANGELES, CAL.**—Mr. Gehricke has been appointed manager of the local branch of the Stromberg Motor Devices Co., of Chicago, Ill., at 945-947 South Main street.

**DEFIANCE, O.**—Edward and John Compo have purchased the large business of the Miller Machine Co. The garage will be conducted in the future under the firm name of Compo Bros. Garage.

**BOSTON, MASS.**—The Velie Boston Branch is to remain in its present headquarters at 92 Massachusetts avenue throughout the 1912 season, the report that a removal was contemplated being incorrect.

**PHILADELPHIA, PA.**—At the annual meeting of the Quaker City Motor Club, to be held early in December at the Hotel Wal-



New salesrooms of the Waverley and Elmore agents at Detroit, Mich.

ton, Clarence Cranmer will be appointed to the secretaryship, vice A. T. James, resigned.

**BOSTON, MASS.**—Manager Chester I. Campbell, of the Boston Automobile Show, with Mrs. Campbell, sailed last week for a trip to Europe where he will look over the foreign shows and compare them with the American ones.

**PORTLAND, ME.**—G. A. Blanchard has taken on the Selden car for this section of Maine, the agency having been closed a few days ago by John D. Murphy, eastern traveling representative of the Selden com-

pany, who is now touring the New England states.

**BOSTON, MASS.**—W. H. Vinal, who organized the Motor Car Co. of Boston and was president of the corporation, has resigned and disposed of his stock to S. S. Anderson. The Motor Car Co. has the New England agency for the Nance six. Mr. Vinal has not made any plans for the immediate future, but he expects to embark in the motor industry later on with a combined pleasure and commercial line. L. W. Abbott has been made sales manager of the company.

## Automobile Incorporations

### AUTOMOBILES AND PARTS

**BOSTON, MASS.**—Fothergill Motor Co.; capital, \$100,000; to sell and make freight automobiles. Incorporators: R. B. Skinner, A. C. York.

**CHARLESTON, OHIO.**—Collison-Pierson & Co.; capital, \$25,000; to buy and sell automobiles. Incorporators: J. F. Collison, D. R. Pierson, W. S. Taylor, O. H. Ashley, A. B. Koontz.

**CHICAGO, ILL.**—Harder Autotruck Co.; capital, \$100,000; to manufacture motor trucks. Incorporators: Henry P. Chandler, J. M. Johnson, K. Cornwall.

**DALLAS, TEX.**—Oldsmobile Co.; capital, \$10,000; to sell automobiles. Incorporators: Rupert E. Paris, R. N. Mosher, Clinton C. Clark.

**DUBUQUE, IA.**—Dubuque-Rambler Auto & Supply Co.; capital, \$20,000; to sell automobiles and accessories. Incorporators: Arch Frater, E. M. Fitzgerald, W. E. Ellwanger.

**INDIANAPOLIS, IND.**—Fedalmobile Mfg. Co.; capital, \$2,500; to manufacture automobiles. Incorporators: Geo. Herff, J. F. Mintborne, A. T. Purcell, P. A. Porteous.

**LOUISVILLE, KY.**—Transit Motor Car Co.; capital, \$20,000; to manufacture and repair automobiles. Incorporators: E. C. Walker, Geo. H. Laib, W. B. Young.

**MEMPHIS, TENN.**—Tri-State Auto Co.; capital, \$1,000; to sell automobiles. Incorporators: J. F. Higan, R. L. White.

**NEWARK, N. J.**—Lenox Motor Car Co.; capital, \$25,000; to sell automobiles. Incorporator: Louis Lippman.

**NORFOLK, VA.**—Virginia Automobile & Repair Corporation; capital, \$10,000; to sell and repair motor cars. Incorporator: H. L. Page.

**TOLDO, OHIO.**—Royal Auto Co.; capital, \$1,000; to sell automobiles and equipment. Incorporators: Marion H. Kennedy, E. B. Parker, B. C. Christen, E. J. Heise, E. M. Warnke.

**TOLDO, OHIO.**—Moore Motor Truck Co.; capital, \$10,000; to build and deal in motor trucks. Incorporators: D. W. Bliss, E. L. Skidmore, C. H. Rauch, E. F. Moore.

**URBANA, ILL.**—Illinois Motor Car Sales Co.; capital increased from \$12,000 to \$25,000.

### AUTOMOBILE GARAGES, ACCESSORIES, ETC.

**BUFFALO, N. Y.**—Herklimer Garage Co.; capital, \$10,000; to deal in crude rubber and rubber goods. Incorporators: Rowland J. Conover, Robert E. Conover, Louis K. Jillson.

**CARROLLTON, OHIO.**—Carrollton Rubber Co.; capital, \$10,000; to deal in crude rubber and rubber goods. Incorporators: Homer J. Richards, John H. Richards, J. R. Williams, James C. Oglsvee, Wm. H. Miller.

**CHICAGO, ILL.**—Empire Top & Supply Co.; capital, \$20,000; to manufacture automobile equipment. Incorporators: Henry Graff, Jr.; Albert N. Charles, Joel E. Bullard.

**CINCINNATI, OHIO.**—Auto Accessories Mfg. Co.; capital, \$15,000; to make automobile accessories. Incorporators: S. C. Roettinger and others.

**FORT WAYNE, IND.**—Merchants Motor Delivery Co.; capital, \$25,000; to conduct a transfer business. Incorporators: A. W. Harris, W. Han, A. H. Fernwalt.

**INDIANAPOLIS, IND.**—Co-Operative Automobile Supply Co.; capital, \$25,000; to deal in supplies. Incorporators: B. H. Rifenburg, J. C. Curtis, J. H. Boesinger.

**PITTSFIELD, MASS.**—Pittsfield Auto Garage Co.; capital, \$3,000; to operate a garage. Incorporators: Mary I. Mills, Arthur A. Mills, Arthur J. Mills.

**PUNXSUTAWNEY, PA.**—Cole Automobile & Transfer Co.; capital, \$10,000; to do a general transfer business.

**ST. LOUIS, MO.**—Curtis Jack & Trust Co.; capital, \$75,000; to manufacture combination jacks and hand trucks. Incorporators: J. R. Curtis, H. C. Flunker, A. W. Smith.

**WASHINGTON, PA.**—American Tire & Filler Co.; capital, \$200,000; to manufacture and sell automobiles. Incorporators: Jas. S. Forsythe, F. C. Lewis, H. J. Johns, R. D. Forsythe, E. W. Rolfe.

# OF INTEREST *to the* INDUSTRY

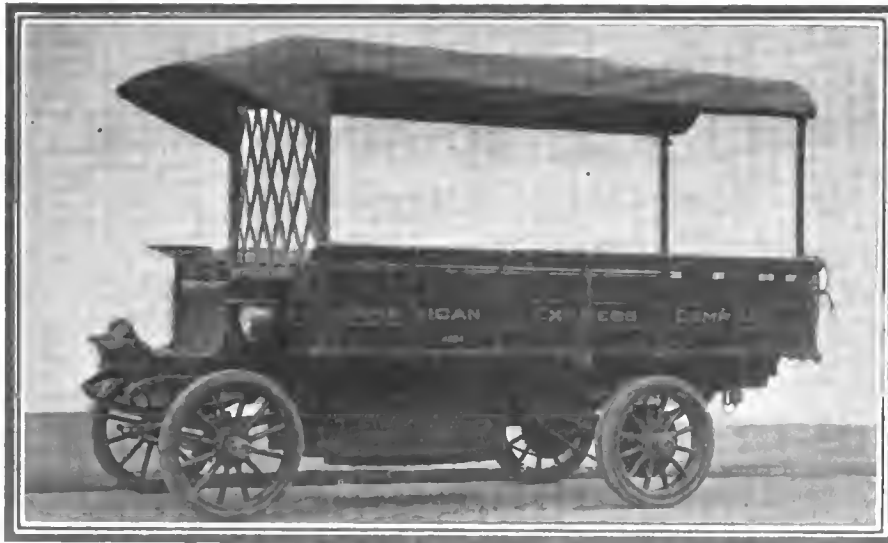

One of the fifty Baker electric trucks ordered by the American Express Company

**CLEVELAND, OHIO.**—An order for fifty electric trucks has been placed by the American Express Company with the Baker Motor Vehicle Company, of this city. For several years the express company has been experimenting with delivery systems using both horses and motor vehicles with the result that the motor-truck system has been found the more satisfactory.

**TULSA, OKLA.**—Tulsa's first automobile factory will be turning out cars by January 1. The factory is that of the Dowagiac Motor Car Company, of Dowagiac, Mich.

**SCHENECTADY, N. Y.**—The Nordyke & Marmon Company, of Indianapolis, Ind., has ordered eighty-two induction motors of the General Electric Company, of this city.

**DETROIT, MICH.**—The Krit Motor Car Co. has just shipped fifty cars to Great Britain and twenty-three to other foreign countries. The company is devoting more attention to its export trade than formerly.

**TOLEDO, OHIO.**—Machinery is being installed at the new plant of the Electric Auto-Lite Company in the rear of the offices at 135-137 Michigan street. Officers are A. W. Fisher, president; S. L. Kelly, vice-president, and C. Q. Miniger.

**FINDLAY, O.**—The Universal Machine Company is removing from Toledo to Bowling Green. The new factory has a floor space of 22,000 feet and will be used for the manufacture of the Toledo marine engine. By the first of the year the company expects to manufacture parts for the Modern Motor Car Company.

**LA PORTE, IND.**—The establishment of a factory to manufacture radiators for plow-

ing engines and possibly automobiles in this city is practically a certainty, and it is expected to erect a factory building this fall. E. H. Scott and Dr. Edward A. Rumely are largely interested in the project.

**DETROIT, MICH.**—The Anderson Electric Car Co. shipped its first trainload of Detroit Electrics from the factory recently. The company has many orders ahead and is running full time. Ten models are being manufactured this year, one of the latest being a roadster with a 96-inch wheel base, a wheel steer and a control device on the wheel.

**NORWALK, O.**—The affairs of the bankrupt Norwalk Motor Car Company are rapidly being wound up by Trustee A. J. Schur before Referee in Bankruptcy Benjamin B. Wickham. Recently a sale of the remaining assets of the company was made to the Model Gas Engine Company, of Peru, Ind., the largest individual creditor, the account being something over \$5,000.

**DETROIT, MICH.**—The recently organized Chevrolet Motor Car Co., which has started clearing ground out Woodward avenue for a large plant, has elected officers as follows: President, William H. Little, of Flint, Mich., formerly general manager of the Buick plant; vice-president and treasurer, Dr. E. R. Campbell; secretary, Curtis R. Hathaway; designer and consulting engineer, Louis Chevrolet; assistant secretary and treasurer, W. W. Murphy. The company will manufacture the Chevrolet Six.

**DETROIT, MICH.**—Contracts were let recently for a large addition to the Scripps Motor Car Co.'s plant on Clinton street

and work is already under way. Work is also about to start on the Hupp Motor Car Co.'s new plant at Milwaukee and Mt. Elliott avenues. The plans have been prepared by architects Dunlap and Palmer and the contracts let. Thus the company will have new factories going up on both sides of the river at the same time, ground having been broken for its Canadian branch in Windsor, Ont., some time ago.

**INDIANAPOLIS, IND.**—The Motor Starting Company has been organized here to manufacture a self-starting device. Quarters have been taken at 427 North Meridian street and factory arrangements are to be made immediately. The device consists of a hand air-pump and small carbureter located on the floor near the driver's seat, with a tube running to each cylinder head. A mixture, consisting of one drop of gasoline to sixty-five parts air, is pumped into the cylinders and a spark causes sufficient combustion to start the motor. Lew W. Cooper is president.

**DETROIT, MICH.**—The pay-rolls of the Packard Motor Car Co. for the month of August, 1911, amounted to \$524,407, probably the largest sum ever paid in wages by any one automobile factory in a single month. At that time there were 7,575 employes at work in the Packard shops. Five buildings were under construction to provide additions to the present floor space of 33 acres. This pay-roll of the company has increased to the enormous figures shown above from \$16,278 in August, 1894, and for the fiscal year of 1903 and 1904 the pay-roll was less than for the month of August, 1911. The fiscal years of 1910 and 1911 showed a pay-roll amounting to \$443,152.

**DETROIT, MICH.**—Honors are about even between the Herreshoff Motor Car Co. and the citizens who have been fighting the company in the courts, in an effort to prevent the establishment of a motor car plant in a fashionable section of Woodward avenue. In the Recorder's court last Thursday Judge Connolly denied a motion made by the company's attorneys to quash the condemnation proceedings instituted by the citizens interested. In the Wayne Circuit court the following day Judge Donovan refused to issue an injunction restraining the building operations, which at no time have been suspended since they were begun several months ago. The factory is now well along and the probabilities are that operations will have started by the time the condemnation proceedings are heard. It is almost certain that the case will go to the Supreme court for final adjustment.

# PATENTS GONE TO ISSUE

**CARBURETER**—Gasoline vaporizer of the single-chamber type.

2. This carbureter has a casing (Fig. 1) which is open at the top and has a lateral discharge opening near the upper end and a gasoline inlet near the lower end, where also a number of openings are provided. Near its upper end the casing is enlarged to form an annular extension into which the outlet merges. A valve is provided for the inlet with a perforated disc connected to it, and an annular screen in the housing, which forms the inner wall of the extension, has inwardly directed lips. A closure for the upper end of the casing engages upon the lips mentioned and holds the screen in position.

No. 1,009,252—to Michael E. Mallo, Greeley, Colo. Granted November 21, 1911; filed November 26, 1910.

**CLUTCH**—Of the multiple-disc type directly connected to the transmission.

2. The patent covers the combination with a variable-speed transmission gearset of a clutch casing detachably secured to the front of the gearbox and supported by the same. A clutch shaft stepped at its rear end in the end of the transmission shaft and at its front end in a bearing in front of the clutch casing has universal joint secured to its front end, a multiple-disc mechanism inside the clutch casing connecting transmission shaft and clutch shaft. Means are provided on the clutch casing for operating the multiple-disc friction mechanism within the casing.

No. 1,009,702—to John G. Utz, Detroit, Mich. Granted November 21, 1911; filed November 22, 1910.

**AUTOMOBILE WHEEL**—In which rocking members and an elastic medium take the place and office of compressed air used in a pneumatic tire.

1. This wheel includes a rim on which a

series of annular members is mounted which may rock independently of their relation to the rim. The terminal portion of each member fits snugly between the terminal portions of the adjoining members and movable relative to them. The terminal portions are connected by elastic means controlling the movement of the members, and they support a tread.

No. 1,009,088—to Charles S. Myers, Columbia, Pa. Granted November 21, 1911; filed September 27, 1910.

**SHOCK ABSORBER**—Friction between contacting discs is used to absorb shocks caused by road inequalities.

4. This patent relates to a shock absorber (Fig. 2) in which a rotary shaft is mounted inside a case and projecting from it to the outside. On the shaft, within the case, a packing gland is mounted, and a disc is also mounted on the shaft. Loose friction plates are provided on each side of the disc. A screw cap is provided for the case, and an annular spring is placed between one of the friction plates and the screw caps.

No. 1,009,454—to Harry C. Turner, Los Angeles, Cal. Granted November 21, 1911; filed August 21, 1907.

**STARTING VALVE**—A device for starting internal combustion engines without mechanical effort.

1. In this device (Fig. 3) a valve is located in a valve casing and its stem extends through a guide way, being operated by the engine, while the valve admits compressed air from a supply pipe through a conduit to a second valve parallel to the first. From the second valve the compressed air is admitted behind the engine piston to start the same, the first valve being automatically thrown open and out of operation when the air is cut off from communication therewith.

No. 1,009,626—to Baxter M. Alakson, Salem, O. Granted November 21, 1911; filed October 14, 1907.

**DEMOUNTABLE RIM**—A number of male and female inequalities in rim and felloe serve to insure engagement of the latter.

3. The patent covers a demountable rim and wheel structure comprising a coned wheel felloe embraced by a frustro-conical band, and a cylindrical wheel rim provided with depressions which carry a removable pneumatic tire sliding over the larger base of the frustro-cone. A wedge ring is secured to the inner front face of the rim and bears against the felloe band to close the open joint between rim and felloe. Outwardly projecting screws in the felloe engage with the rim depressions, thus keeping the rim in place on the wheel.

No. 1,009,103—to Robert P. Scott, Cadiz, Ohio. Granted November 21, 1911; filed June 15, 1909.

**TRANSMISSION MECHANISM**—Shaft drive combined with a live rear axle.

2. This mechanism comprises two rotary power transmitting wheels, a wheel fixed longitudinally and laterally with respect to one of the power transmitting wheels, and removable means for fixing the same to the other power transmitting wheel.

No. 1,009,435—to Ralph L. Morgan, Worcester, Mass.

**SPARK PLUG**—Containing electrodes for both high- and low-tension currents.

1. The igniter covered by this patent comprises a hollow bushing carrying a low-tension electrode, which supports a high-tension electrode separated from it.

No. 1,008,178—Carl Messersehm, New York, N. Y., assignor to The Duplex Magneto & Spark Plug Co., Brooklyn, N. Y. Granted November 7, 1911; filed January 6, 1911.

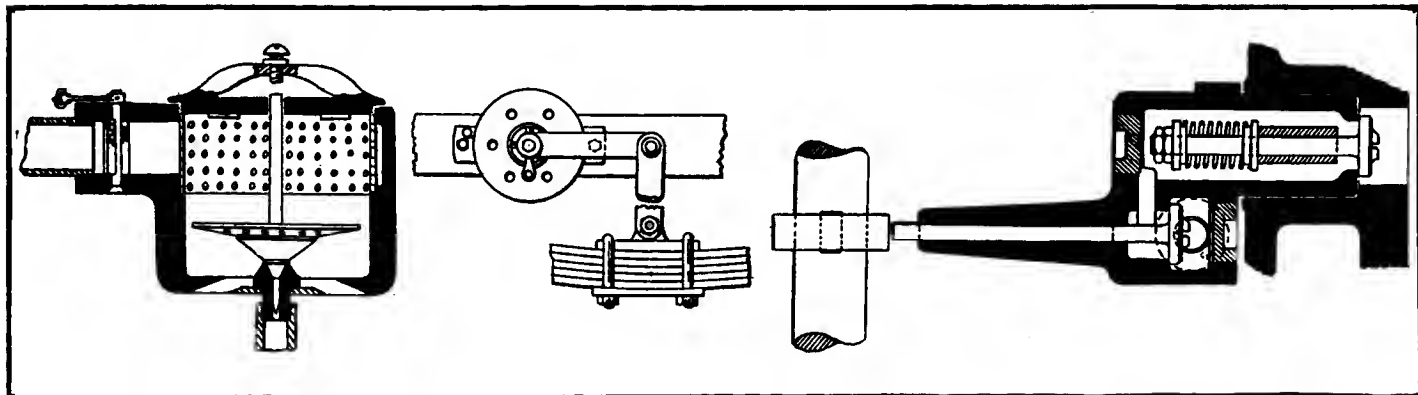

Fig. 1—Mallo carbureter.

Fig. 2—Turner shock absorber.

Fig. 3—Alakson starting valve



# Newest Ideas Among the Accessories

## Jacobson Air Compressor

THE Jacobson air compressor, Fig. 1, is of the garage type built by the Jacobson Machine Mfg. Co., of Warren, Pa. It is designed with the object of meeting the specific need of automobile

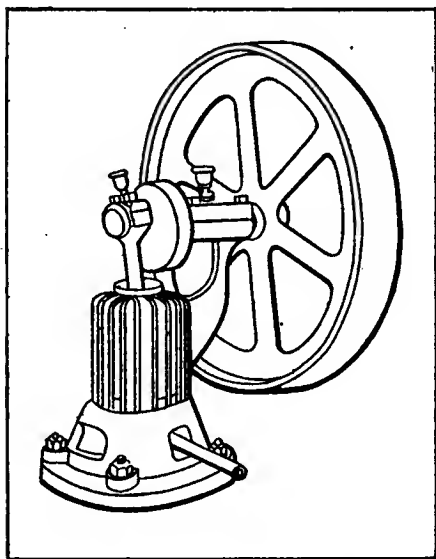

Fig. 1.—Jacobson air compressor

owner or garage operator, by a combination of maximum capacity with minimum volume and weight. As Fig. 1 shows, this type has a cylinder which is air-cooled and cast in one piece with the bearing housing. The bore of the cylinder is 3 inches and the stroke 4 inches, and 200 revolutions of the crank are equivalent to 3½ cubic feet of air delivered by the compressor. The piston, which has three expansion rings, is of the trunk pattern, and the valves are made of a special grade of bronze. The bearings are made adjust-

able so as to overcome the effects of wear, and all parts are made in standard dimensions for the sake of interchangeability. The flywheel by which the engine may be driven is crowned for this purpose, but a small driving pulley may be procured with the machine, if this type of drive is preferred to the one by the flywheel. The weight of the machine is 200 pounds and the total floor space occupied by it 20 by 24 feet.

## Federal Auto Washer

The Federal Auto Washer is shown installed in a garage in Fig. 3. The advantages of this system are that it is attached to the ceiling and, while it has a considerable range of action, will not be found to be in anyone's way in the garage. The top piece is held to the ceiling by four screws, and from it is suspended by a supporting arm and an elbow, a horizontal pipe, 4 feet 4 inches in length. This pipe may be turned in any direction, being connected to the top portion, into which the pipe from the water main leads, by a connection of standard dimensions. A rubber hose is attached to the end of the vertical pipe, and the other end of the hose carries a nozzle by means of which a stream of water may be directed against the body of the car. The flow of the water is regulated by a gate valve interposed at the wall in the branch of the water mains supplying the water, but it is also possible to use a nozzle with another valve permitting of the operator's starting and stopping the water while standing by the car. This washer is manufactured by the Walworth Mfg. Co., 132 Federal street, Boston, Mass., which is also acting as distributor and selling agent for the New England States.

## American Self-Starter

The American Self-Starter is one of the systems in which acetylene derived from the gas tank is used to start the automobile engine on the spark. The system is installed in the manner illustrated in Fig.

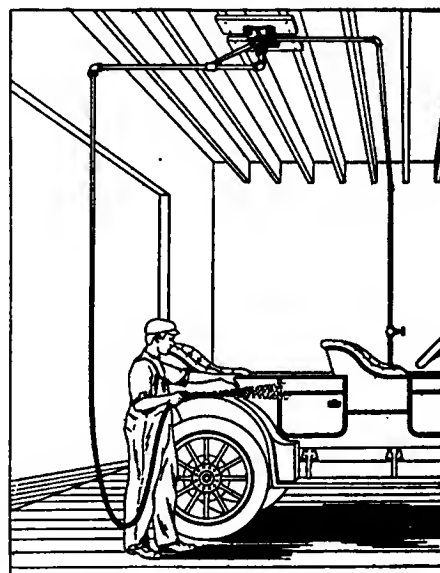

Fig. 3.—Federal Auto Washer

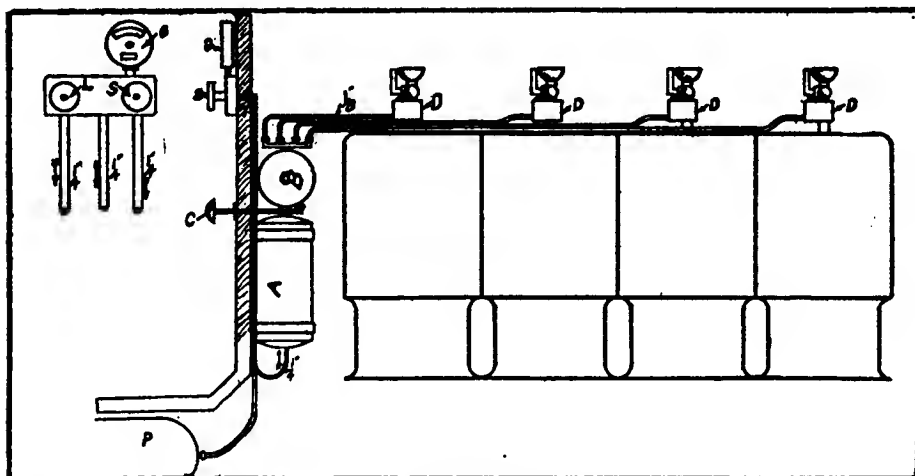

Fig. 2.—American self-starter system

2. The pressure tank A is installed on the front of the dashboard and securely fastened thereto. The push rod C extending from it should be in a position easily reached by the driver's foot. Then the priming cups are removed from the cylinders and the check valves D inserted in their places, and the controller with valves L for regulating the lights, and S for admitting gas to the starter is installed upon the dashboard. Valve L is connected with the lamps and S with the check valves in the cylinder heads, and connection is also made between gas tank P and needle valve B of the pressure tank A. For the latter purpose the maker of the starter supplies ½-inch brass tubes and patent lead packing for all joints and unions. Metal clasps are used to tie the tubes together to prevent rattling. For starting G the controller valve S is turned by its handle until the gauge above the controller registers 30 pounds pressure in the pressure tank; then the push rod C is pressed, releasing the compressed gas from the tank and directing it into one or two of the cylinders, whereupon the spark is thrown on. This process, it is claimed, will start the engine in any weather. The American Self-Starter system is handled in the New England States by the New England Sales & Equipment Co., 100 Boylston street, Boston.

# THE AUTOMOBILE

## Fiat, Bruce-Brown, Wins Grand Prize



Scene When Bruce-Brown in the Winning Fiat Crossed the Tape in the Grand Prize at Savannah. The Winning Driver and His Mechanician

SAVANNAH, GA., Nov. 30—David Bruce-Brown, in a Fiat special racing car, to-day won the Grand Prize race after one of the most spectacular struggles ever seen in a road race in America. In this struggle Eddie Hearne, in a Benz, Ralph De Palma, in a Mercedes, and Ralph Mulford in a Lozier, were his greatest rivals. Brown put his Fiat over the 411.36 miles at an average pace of 74.45 miles per hour, scarcely 1-2 mile an hour faster than the Vanderbilt was won on the same course 3 days before. Brown won by the narrow margin of 2 minutes and 2 seconds over Hearne in the Benz; De Palma, in his Mercedes, was third, being but 3 minutes and 9 seconds back of the Fiat. Bragg, who finished fourth in a Fiat, was 20 minutes back of Brown.

Mulford, in the Lozier, was less than 2 minutes behind Brown at the end of the twenty-second lap, but he went out in the first part of the twenty-third lap, due to breaking of the main shaft extension of the gearset.

TABLE SHOWING THE PERFORMANCE OF THE CARS IN THE GRAND

No.	CAR	DRIVER	Lap Miles									
				17.14	34.28	51.42	68.56	85.70	102.84	119.98	137.12	154.26
48	FIAT	David Bruce-Brown	Elapsed Time		25:54	38:52	58:31	72:17	85:31	98:38	111:38	124:31
			Lap Time	13:07	12:47	12:58	19:39	13:46	13:14	13:07	13:00	12:53
47	BENZ	Eddie Hearne	Elapsed Time		27:02	40:19	53:34	66:54	80:16	95:30	108:39	122:02
			Lap Time	13:43	13:19	13:17	13:15	13:20	13:22	15:14	13:09	13:23
55	MERCEDES	Ralph DePalma	Elapsed Time		26:25	39:49	53:08	68:20	86:06	99:29	113:02	126:34
			Lap Time	13:15	13:10	13:24	13:19	15:12	17:16	13:23	13:33	13:32
53	FIAT	Caleb Bragg	Elapsed Time		25:51	38:51	54:25	67:23	82:38	95:37	110:48	123:55
			Lap Time	13:01	12:50	13:00	15:34	12:58	15:15	12:59	15:11	13:07
42	POPE HUMMER	Louis Disbrow	Elapsed Time		29:27	43:57	58:39	73:12	87:47	102:15	116:50	131:27
			Lap Time	14:55	14:32	14:30	14:42	14:32	14:35	14:28	13:35	14:37
44	ABBOTT-DETROIT	L. A. Mitchell	Elapsed Time		32:43	48:52	64:50	80:55	96:57	112:45	130:27	148:37
			Lap Time	16:39	16:04	16:09	15:58	16:05	16:02	15:48	17:42	18:10
45	LOZIER	Ralph Mulford	Elapsed Time		27:20	40:59	54:46	68:06	81:54	95:37	109:25	123:03
			Lap Time	13:45	13:35	13:39	13:47	13:20	13:48	13:43	13:48	13:38
50	ABBOTT-DETROIT	Carl Limberg	Elapsed Time		31:54	47:30	63:00	78:47	94:17	111:53	127:40	143:29
			Lap Time	16:09	15:45	15:36	15:30	15:47	15:30	17:36	15:47	15:49
41	FIAT	Louis Wagner	Elapsed Time		26:16	42:00	55:32	68:40	81:40	96:42	109:37	122:50
			Lap Time	13:18	12:58	15:44	13:32	13:08	13:00	15:02	12:55	12:48
43	BUICK-HUNDRED	Charlie Basle	Elapsed Time		29:54	44:28	58:46	75:56	90:08	104:01	117:59	131:54
			Lap Time	15:02	14:52	14:34	14:18	17:10	14:12	13:53	13:58	13:55
51	MARMON	Cyrus Patchke	Elapsed Time		27:59	41:25	54:46	68:10	81:32	94:55	108:16	121:40
			Lap Time	13:57	14:02	13:26	13:21	13:24	13:22	13:23	13:21	Out—
54	MERCEDES	Spencer Wishart	Elapsed Time		27:19	40:07	53:55	67:20	80:45	94:10	107:35	121:00
			Lap Time	13:37	13:42	12:48	12:48	13:25	13:25	13:31	15:59	Out—
52	BENZ	Erwin Bergdoll	Elapsed Time		27:14	40:48	54:10	67:45	81:10	94:35	107:55	121:10
			Lap Time	13:37	13:37	13:34	13:32	16:35	28:34	37:46	Out—	Second gear
56	BENZ	Victor Hemery	Elapsed Time		26:23	39:07	52:38	65:58	79:13	92:28	105:43	118:58
			Lap Time	13:17	13:06	62:44	47:31	12:36	25:25	12:43	Out—	Brcke ex.
46	MARMON	R. Burman	Elapsed Time		27:35	40:58	54:22					
			Lap Time	14:01	13:34	13:23	13:24	Out—	Sheared pins in magneto shaft coupling			
49	BUICK-HUNDRED	Harry Cobe	Elapsed Time		31:26							
			Lap Time	15:39	15:47	Out—	Upset on turn					

FASTEST CAR IN EACH LAP

Lap Car	Driver	Time	Speed
1 Fiat	Bragg	13:01	79.0
2 Fiat	Brown	12:47	80.4
3 Fiat	Brown	12:58	79.3
4 Benz	Hearne	13:15	77.6
5 Benz	Hemery	12:36	81.6
6 Fiat	Wagner	13:00	79.1
7 Benz	Hemery	12:43	80.8
8 Fiat	Wagner	12:55	79.6
9 Fiat	Wagner	12:48	80.3
10 Fiat	Brown	12:48	80.3
11 Benz	Hearne	13:22	76.9
12 Fiat	Wagner	12:51	80.0
13 Fiat	Bragg	13:08	78.3
14 Fiat	Wagner	12:48	80.3
15 Fiat	Brown	13:12	77.9
16 Fiat	Brown	13:16	77.5
17 Mercedes	DePalma	13:26	76.5
18 Fiat	Bragg	13:04	78.7
19 Fiat	Bragg	13:09	78.3
20 Fiat	Bragg	13:08	78.3
21 Fiat	Brown	13:01	79.0
22 Mercedes	DePalma	13:28	76.3
23 Fiat	Bragg	12:49	80.2
24 Fiat	Bragg	12:59	79.2



The winning Fiat, getting away after a stop at the pits

Brown's average of 74.45 miles an hour sets a new record for road races of this distance in America. By to-day's victory he was enabled to claim equal honors as a road race repeater with Harry Grant, winner of the Vanderbilt cup race last year, when he won it for the second successive time in an Alco car; and also with Thery, the celebrated European driver, who won the Gordon-Bennett race in 1904 and again in 1905 in a Brasier car.

Brown's victory this year was popular. Being the winner of the Grand Prize last year he was a strong favorite, with the masses and much speed was expected from his Fiat racer. His great rivals to-day before the race started, were Wagner in another Fiat and Victor Hemery in a Benz. Last year Hemery was but 1.32 seconds behind Brown, the year before he was but a few seconds behind Wagner who won in a Fiat, and this year many were looking to him to carry off the laurels. It was known in practice that he had the fastest car on the course and this was proved to-day when he made the fastest lap, averaging 81.61 miles, an hour for a circuit. But luck was against him good and strong to-day. In the third lap he broke an exhaust valve and was over one hour making the circuit, which eliminated him as a contender, but he effected a repair and made seven laps when he was compelled to retire, due to the same trouble. Wagner, the winner of the grand prize race 2 years ago, was looked upon as a probable leader to-day, in fact, more expected him

to win than Bruce-Brown, but he, too, was doomed to disappointment. He had many cases of tire trouble and in taking a turn too fast in the fourteenth lap ran off the course and damaged his steering-gear and withdrew when he reached the grandstand. With his elimination the two great European drivers were out and the American speed pilots on foreign and domestic cars were left to wage the battle.

TABLE SHOWING THE POSITION OF EACH CAR

No.	Car and Driver.	Lap	1	2	3	4	5	6	7	8
48	FIAT, Bruce-Brown	2	2	2	8	8	6	5	6	6
47	BENZ, Hearne	7	6	4	2	1	1	2	2	7
55	MERCEDES, DePalma	3	5	3	1	5	7	6	7	7
53	FIAT, Bragg	1	1	1	5	2	5	3t	5	5
42	POPE HUMMER, Disbrow	11	12	10	9	9	8	7	8	8
44	ABBOTT-DETROIT, Mitchell	15	16	13	12	12	11	10	11	11
45	LOZIER, Mulford	8	9	7	6t	3	4	3t	3	3
50	ABBOTT-DETROIT, Limberg	14	15	12	11	11	10	9	10	10
41	FIAT, Wagner	5	3	9	7	6	3	4	4	4
43	BUICK 100, Basle	12	13	11	10	10	9	8	9	9
51	MARMON, Patchke	9	11	8	6t	4	2	1	1	1
54	MERCEDES, Wishart	6t	8	14	13	13	13	11	12	12
52	BENZ, Bergdoll	6t	7	5	3	7	12	12	12	out
56	BENZ, Hemery	4	4	15	14	14	14	14	13	out
46	MARMON, Burman	10	10	6	4	out				
49	BUICK 100, Cobe	13	14	out						

PRIZE RACE OF THE A. C. A., SAVANNAH, GA., NOVEMBER 30, 1911.

10	11	12	13	14	15	16	17	18	19	20	21	22	23	24	Miles per Hour
171.40	188.54	205.68	222.82	239.96	257.10	274.24	291.38	308.52	325.66	342.80	359.94	377.08	394.22	411.36	
137:19	152:30	166:15	179:27	195:19	208:31	221:47	237:12	250:23	263:46	277:04	290:05	305:24	318:17	331:29.13	74.45
12:48	15:11	13:45	13:12	15:52	13:12	13:16	15:25	13:11	13:23	13:18	13:01	15:19	12:53	13:12	
135:22	148:44	162:11	178:27	192:12	206:57	220:24	234:08	248:07	263:03	277:35	290:41	304:42	319:47	333:33.07	74.04
13:20	13:22	13:27	16:16	13:45	14:45	13:27	13:44	13:59	14:56	14:32	13:06	14:01	15:05	13:46	
140:06	153:34	167:08	180:42	194:19	208:00	224:55	238:21	251:52	267:25	281:16	294:44	308:12	321:26	334:40.80	73.76
13:32	13:28	13:34	13:34	13:37	13:41	16:55	13:26	13:31	15:33	13:51	13:28	13:28	13:14	13:14	
137:11	165:55	178:54	192:01	207:59	221:44	235:17	248:55	261:59	275:07	288:15	309:43	326:03	338:52	351:55.29	70.13
13:16	28:44	12:59	13:08	15:57	13:45	13:33	13:38	13:04	13:08	13:08	21:28	16:20	12:49	12:59	
146:13	171:01	184:44	199:25	214:08	233:59	249:42	276:31	298:15	313:11	327:49	342:34	357:23	372:04	386:44.60	63.84
14:46	23:48	14:43	14:41	14:43	19:51	15:43	26:49	21:44	14:56	14:38	14:45	14:49	14:41	14:40	
165:26	181:45	198:04	214:18	230:34	246:51	270:42	287:17	304:02	320:35	337:32	355:48	374:04	393:36		60.09
16:49	16:19	16:19	16:14	16:16	16:17	23:51	16:35	16:45	16:33	16:57	18:16	18:16	19:32	Running at end of race	
140:07	154:00	167:39	181:12	194:50	208:28	222:05	235:45	249:28	263:18	277:18	291:13	305:08	318:55	332:44	
17:04	13:53	13:39	13:33	13:38	13:38	13:37	13:40	13:43	13:50	14:00	13:55	13:55	13:55	Broke rear axle drive shaft	
159:05	174:39	190:26	206:04	224:41	241:04	257:02	272:51	307:38	336:17	353:02	374:05			Running when race was called	
15:36	15:34	15:47	15:38	18:37	16:23	15:58	15:49	24:47	28:39	16:45	21:02				
136:56	152:14	165:05	179:48	192:36											
14:31	15:18	12:51	14:43	12:48	Overran turn and injured steering gear										

Engine trouble

Cracked cylinder

could not be disengaged

valve

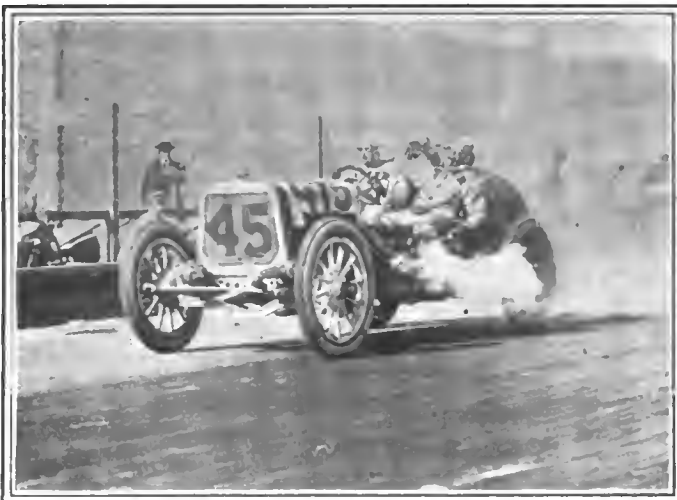

The Mulford Lozier looked like a winner at one stage of the race

A cursory analysis of the performance of Brown in his Fiat will show what difficulties he had to contend with from start to finish. His task was not that of defeating Hearne, or Mulford or De Palma, but at different stages of the contest he had to battle with the speedy Wagner, with the equally speedy Bragg, with the speed king Hemery, with Patschke and with Burman. He ran second for the first three laps, then dropped to eighth

No.	Car	Driver	Lap	Time	Speed, Miles per Hour
56	BENZ.....	Hemery.....	5	12:36	81.61
48	FIAT.....	Brown.....	2	12:47	80.50
41	FIAT.....	Wagner.....	9	12:48	80.3
53	FIAT.....	Bragg.....	22	12:49	80.2
47	BENZ.....	Hearne.....	21	13:06	78.5
55	MERCEDES.....	DePalma.....	2	13:10	78.1
45	LOZIER.....	Mulford.....	5	13:20	77.1
51	MARMON.....	Patske.....	4	13:21	77.0
46	MARMON.....	Burman.....	3	13:23	76.8
54	MERCEDES.....	Wishart.....	5	13:25	76.6
52	BENZ.....	Bergdoll.....	4	13:32	75.9
43	BUICK.....	Basle.....	7	13:53	74.0
42	POPE.....	Disbrow.....	7	14:28	71.0
50	ABBOTT.....	Limberg.....	4	15:30	66.30
49	BUICK.....	Cobe.....	1	15:39	65.70
44	ABBOTT.....	Mitchell.....	6	16:02	64.1

place which he held for a couple of circuits. He mounted to sixth in the sixth lap; went to fifth in the seventh; only to fall back to sixth in the eighth. In lap nine the dropping out of Patschke raised him one and he gained another due to the fortunes of tires in road racing, so that at the end of the circuit he was in fourth place. He remained fourth in laps nine and ten; was third in eleven and twelve; and was second in lap thirteen, being exactly 1 minute back of the flying Hearne in the Benz. But when almost within striking distance of first he stopped to change tires, made a slow lap in 15:52, Benz took the lead and Brown found himself in fifth place. Then he had to begin climbing all over again. But he kept steadily at it. By the end of lap fifteen he was back in third place having got in in advance of Bragg in the other Fiat, and also the Lozier. Lap sixteen saw him in second place with the Benz ahead; but he dropped to third in laps seventeen, eighteen and nineteen. Then at one fell swoop he jumped ahead of both Hearne and Mulford, and took first place. He held it for lap twenty-one, but Hearne was close on his heels, being only 36 seconds back of him and Mulford little more than a minute in the rear. Then came the fatal end of the twenty-second, when all three of them stopped. Fiat got away with an advantage of over a minute on the Benz and it was all over but the shouting, because Brown was first in the twenty-third lap and first in the twenty-fourth. Through

AT THE END OF EACH LAP OF THE GRAND PRIZE

	9	10	11	12	13	14	15	16	17	18	19	20	21	22	23	24
4	4	3	3	2	5	3	2	3	3	3	1	1	3	1	1	
1	1	1	1	1	1	1	1	1	1	1	1	3	2	1	2	2
6	5	4	4	4	3	2	4	4	4	4	4	4	4	4	3	3
5	3	6	6	6	6	5	5	5	5	5	5	5	5	5	4	4
7	7	7	7	7	7	6	6	6	6	6	6	6	6	6	5	5
10	9	9	9	9	9	8	8	8	8	7	7	7	7	7	6	6
3	6	5	5	5	4	4	3	2	2	2	2	2	3	2	out	
9	8	8	8	8	8	7	7	7	7	8	8	8	8	8	running	
2	2	2	2	3	2	out										
8	out															
out																

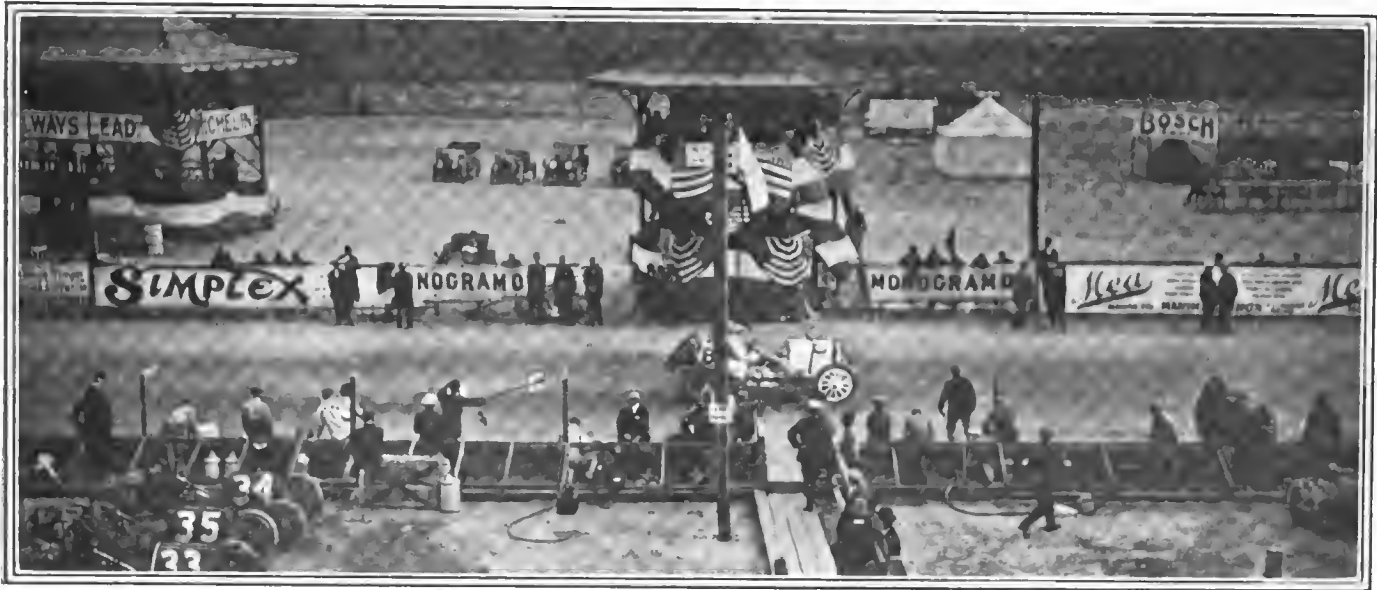

Looking across the track from the paddock. The pits are in the foreground and the timers' stand on the opposite side of the track

all of this changing, the like of which was never before seen in a road race in this country, Brown worked coolly along. He changed twelve tires from start to finish. He changed all of these at the pits, seven being changed at the tire repair station on the backstretch and five at the grandstand pits. In five of the stops he changed two tires at a time, both rear wheels and in the other two stops he changed one tire each. He did not make a tire change at any point along the course.

### Most Thrilling Race in America

To-day's race was one of the most spectacular ever seen in America. There were sixteen cars that faced the tape and got away in good shape. Of these only five finished the twenty-four laps, but two more, the Abbott-Detroits, were running at the finish. Nine cars were compelled to give up the gruelling struggle. From the start to the end of the twenty-second lap the race might have been won by Brown in the Fiat, by Hearne in the Benz, by Mulford, in the Lozier, or by De Palma, in his Mercedes. At this point Hearne led, being 24 seconds ahead of Mulford and 42 seconds ahead of Brown; De Palma was over 3 minutes back. It required only a little unexpected tire trouble to make any one of the three a leader. Hearne had his in the second to the last lap and in the same lap Mulford was retired, leaving the course clear for Brown and his Fiat.

From start to finish the race was one of never-ending interest. The leadership changed no fewer than seven times in the

twenty-four laps. Caleb Bragg, in a Fiat, a duplicate of the one Brown drove, led for the first three circuits, but fell behind De Palma in the fifth, due to tire troubles; De Palma held the lead for but a single circuit when it fell into the keeping of Eddie Hearne and his Benz who maintained it for laps five and six. Then he dropped it into the hands of Cyrus Patschke in his Marmon, who held it for laps seven and eight, when he dropped out of the race. From the start of the race Hearne had been making laps in 5 to 6 seconds under Patschke, so that as soon as tire troubles overtook him, Patschke was ready to grab the lead. When the Marmonite eliminated himself at the end of the eighth with engine troubles, Hearne was at hand, being only 9 seconds behind, and took the lead in the ninth with a margin of 1 minute over the Lozier and about the same on Wagner. Hearne held this lead until the twentieth lap, when for the first time, it fell into the hands of Bruce-Brown, who for the five previous laps had been steadily cutting down the lead Hearne had established earlier in the race. When Brown took the lead in lap twenty, he had only 31 seconds on Hearne, but he kept it and led in lap twenty-one by 36 seconds.

Lap twenty-two saw a change of leadership when Hearne by his dogged perseverance once again got into the front rank with a lead of 42 seconds on the Fiat, which lost its advantage, due to tire troubles.

Here, with only two laps to go, came the catastrophe. Brown, Hearne and Mulford all stopped at the pits. They were all there



De Palma's Mercedes and Hemery's Benz were the last away. De Palma ready for the word



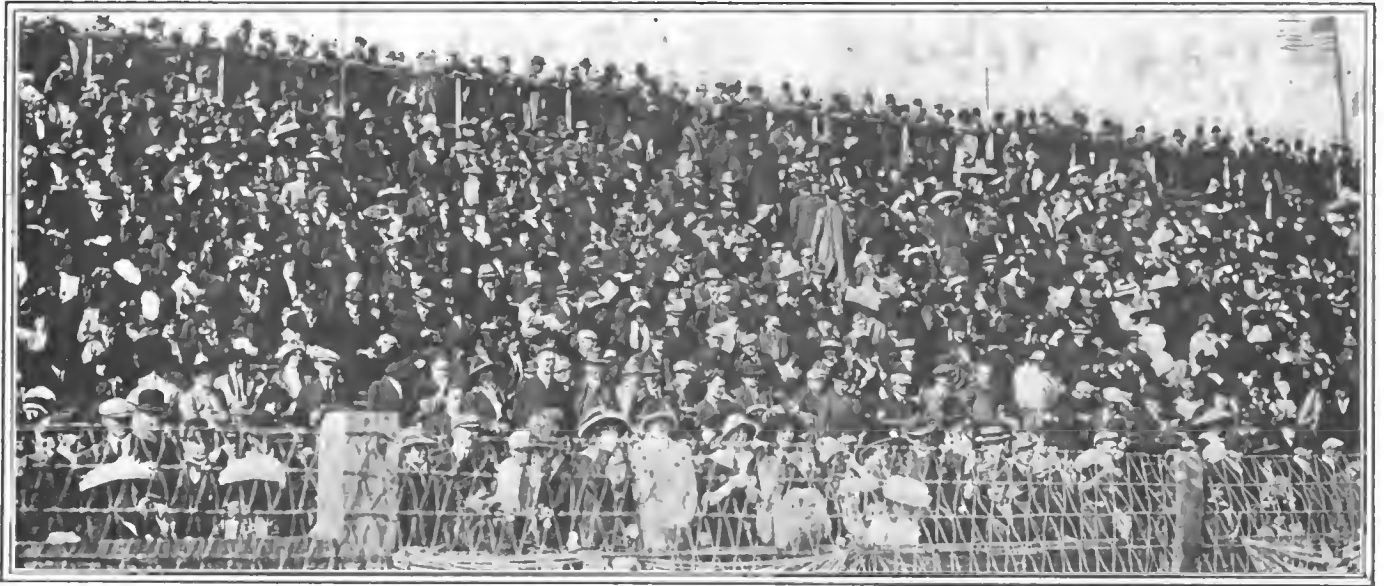

The immense crowd at the grand stand included automobile enthusiasts of every section of the country

together. It was the most exciting moment ever witnessed in this or any other country in a road race. The Fiat was first into the pit to change tires. Not more than 3 or 4 seconds later came Mulford and then Hearne. Lozier took on gasoline only and was first away. Fiat second and Benz last. Everybody knew that the Fiat could make the fastest lap and so it did. It took first place in the twenty-third lap and held it for the twenty-fourth, winning by a margin of over 2 minutes. Many thought the Benz would have won if it had not stopped to change tires, but no one really knows. Hearne was fatigued from driving and would not take any chances in holding the car on the turns should a tire go. As it was Brown proved himself the same wonderful uphill fighter he was a year ago and Mulford and Hearne endeared themselves to every one by putting up the gamest fight that has been witnessed in a road race. De Palma, who finished third, was a strong favorite all day.

The elimination story was a particularly heavy one in that of the sixteen starters only five finished the twenty-four laps, and of these the Pope, driven by Disbrow was the only American car. Two other American cars were consistently running at this time, one being No. 44 Abbott-Detroit, piloted by Mitchell, and the other No. 50 Abbott-Detroit, driven by Limberg. Mitchell covered twenty-three laps of the circuit when he was flagged off and Limberg had negotiated twenty-one laps when he was called off, the race being declared over and the course thrown open. Had the two Abbotts been allowed to finish, which they un-

doubtedly would have done, it would have given America three cars at the finish as compared with four foreign machines that completed in the entire race.

### Why the Cars Dropped Out

When it comes to the story of why the cars dropped out, attention is first drawn to the foreign ranks, as they were the first to be broken. Hemery was first in trouble, due directly to an exhaust valve giving away under the terrific speed. Undoubtedly the speed at which Wishart pushed his Mercedes was more or less responsible for the cracked cylinder, which caused his withdrawal. Bergdoll's trouble was not being able to shift from second speed. Wagner was eliminated by too fast driving on the curves and putting his steering-gear out of commission when he ran off the road. The other four foreign cars finished.

Five American cars were eliminated. First out was Cobe, in Buick, who upset on a curve. He was the first to give up the race. Second to drop out was the special Marmon car, driven by Burman. It stopped just before reaching the grandstand at the start of the fifth lap. The trouble consisted in the sprocket on the magneto shaft being destroyed. In lap 10 Patschke, driving the other Marmon withdrew, due to cylinders being loosened from the crankcase. He was leading when he pulled out. Basle, in a Buick, was next, dropping out in the following circuit. Mulford, in a Lozier as already stated, fell out in the start of the twenty-third lap, his trouble being the breaking of the main shaft

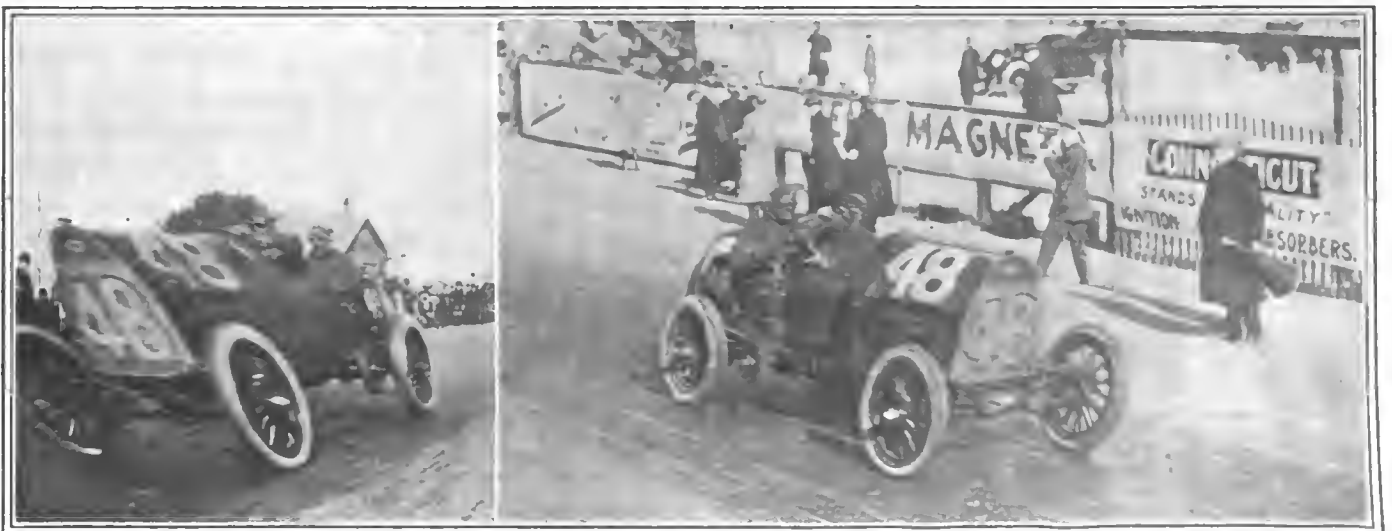

Two views of the winning Fiat in action. On the backstretch the staff photographer was enabled to get a close shot at the fast-flying Italian

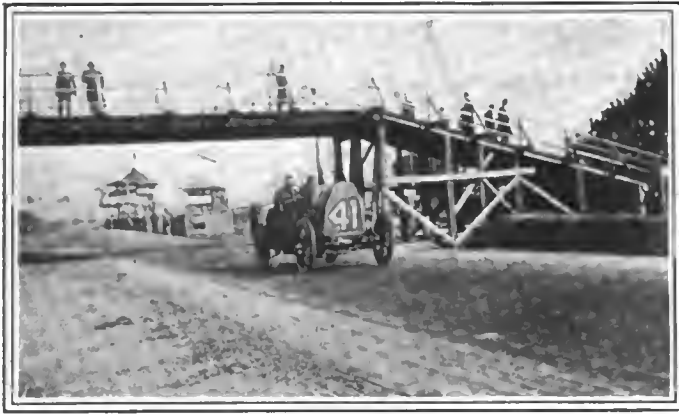

Wagner's Fiat endeavoring to make up lost time

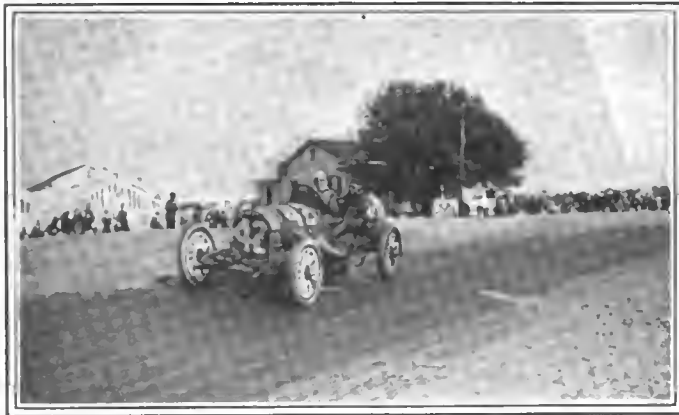

The Pope-Hummer did excellent work throughout the race



Mulford's Lozier in full cry at the head of the stretch



What caused Hearne to lose a very comfortable lead

## Scenes Here and There

extension of the gearset. This shaft protrudes from the forward end of the gearbox and unites through a sliding joint and universal coupling with the clutch. Examination showed a slight flaw in this part, despite which the shaft proved sufficiently strong to carry the car to victory through the seventeen laps of the Vanderbilt Cup race and for twenty-two laps of the Grand Prize event.

## Grand Prize in Detail

Lap 1—The foreign half of the racers set out to win everything in the first lap and when the end of the circuit was over, the eight foreign cars were in the van and the eight American cars in a group at the rear. The foreign eight averaged 77.3 miles an hour, as compared with an average of 68.7 miles an hour for the eight domestic cars, a difference of practically 9 miles an hour, a big handicap for the opening circuit. Bragg in his Fiat led the field by making the 17.14 miles from a standing start in 13:01, a speed of 79 miles an hour. But he was not alone, Brown in another Fiat averaged 78.4 miles an hour; De Palma in the Mercedes averaged 77.9; Hemery in a Benz 77.7; Wagner in a Fiat 77.6; Bergdoll in a Benz 75.4, and Wishart, Mercedes, 75.4. Hearne, Benz, who finished second in the race, was last of the foreigners in this lap with an average of 74.9 miles an hour. Mulford, who headed the American octette was close on the heels of Hearne, being but 2 seconds slower in the lap; Patschke with his Marmon was 12 seconds slower, and Burman in the other Marmon 16 seconds behind. Burman was just a minute slower than Bragg for the lap.

Thus did the first eleven racers complete the lap with only a minute's difference between the fastest and slowest. The remaining five cars were slower, as follows: Disbrow, Pope-Hummer, 14:55; Basle in Buick, 15:02; Cobe in Buick, 15:09; Limberg in Abbott-Detroit, 16:09, and Mitchell in Abbott-Detroit, 16:39, the last being at a pace of 61.7 miles per hour. There was a difference of 3 minutes 38 seconds between Bragg, the leader and Mitchell, the tail-ender.

Lap 2—The second circuit saw the eight foreigners still in a group at the front, with the eight American machines bunched in the rear. But there was only 1 second between Wishart, who was last in the foreign contingent, and Mulford's Lozier that was leading the home squadron. This was a Fiat lap, as they led in one, two, three fashion at this point, the order being Bragg, Brown and Wagner, with Victor Hemery, hope of the Benz camp, but 7 seconds behind Wagner, who was looked upon as the fastest of the Fiat trio. This lap saw several changes of position.

By making the lap in 13:09, a speed of 77.5 miles an hour, Hearne jumped from the last of the foreigners up two places, and Wagner, by sending his Fiat over the 17.14 miles in 12:58, 79.3 miles an hour, climbed past De Palma's Mercedes and Hemery's Benz, so the foreigners at the end of the lap stood Fiat, Benz and Mercedes. Mulford still headed the American cars. He made the circuit in 13:35, 75.6 miles an hour, his lap being 10 seconds faster than his first. Burman was second, having made the lap in 13:34, a second faster than Mulford, Patschke, dropped into third by a slower lap in 14:01. The positions of the other five American cars did not change, it being Disbrow, Pope; Basle, Buick; Cobe, Buick; Limberg, Abbott, and Mitchell, Abbott. There was at this point a difference of 6 minutes 32 seconds between the leader, Bragg, and Mitchell, who was bringing up the rear. Only two cars in this lap averaged over 80 miles per hour, these being the Bragg and Brown Fiats. Burman's Marmon was the fastest American car, doing the lap at

## on Grand Prize Course

75.7 miles an hour with Mulford next, averaging 75.6 miles an hour.

Lap 3—This lap witnessed the breaking up of the united lead of the foreigners, Burman, Mulford and Patschke with their American cars having broken into the European phalanx, by getting ahead of Wagner's Fiat which had to stop at the grandstand pits for tires, they having passed Hemery's Benz that broke an exhaust valve and Wishart's Mercedes which had chain trouble. It was a case of five Europeans heading the race at this point, closely pursued by the three American cars, then Wagner's Fiat, next four Americans and last Hemery and Wishart, Cole's Buick went through the outer fence at the Montgomery cross road turn and upset. Fortunately nobody was hurt. This could not be looked upon in any other way than that of being a Fiat lap. Bragg and Brown were first and second, De Palma had his Mercedes in third, almost a minute back of the Fiats and the two Benzes were fourth and fifth, Hearne and Bergdoll being the order. This lap was a distinctive gain for the home cars, Burman averaging 76.8 miles per hour. Both of the Marmons were faster than Mulford's Lozier, the times being: Burman, Marmon, 13:23; Patschke, Marmon, 13:26; Mulford, Lozier, 13:39.

The remaining four American cars were running more than a minute to the lap slower than these three so everyone looked to Burman, Patschke and Mulford to wage the bitter war against the Fiats, Benz and Mercedes racing machines. Nobody knew at this moment what would be the outcome. The enormous speed of the foreigners had started to show its results in two different ways, in tires, Wagner having to change both rears after but three laps, and in mechanical troubles, both Hemery and Wishart's machines not being equal to the enormous speed possibilities of the course. Would Bragg and Brown still be able to maintain the 79-mile-an-hour pace they were setting? If they could the American car would have but little chance. Not taking into consideration Wishart and Hemery, who were tail-enders, there was at the end of this lap a difference of 10 minutes between the leader Bragg and Mitchell, last of those actually running steadily.

### Fiat Loses the Lead

Lap 4—This lap was a Fiat catastrophe. For the first time the Italians lost the leadership, De Palma's Mercedes gaining first place, with Hearne and Bergdoll in the two Benz machines second and third and Burman's Marmon fourth. An American car had jumped from eleventh to fourth place in four laps. The Fiats' downfall was due to tires. Bragg had to change and so had Brown. Brown's stop was a long one, making the lap time 19:39, by far the slowest one he had in the entire Grand Prize race. He dropped abruptly from second to eighth place, and many thought that his hopes for victory had gone with his tires. The race was becoming interesting, with an American car fourth and two others sixth and seventh. Everyone felt settled that the Fiats could not continue their 79 miles an hour without having to change tires every three or four laps, and as the driver and mechanic had to do all of the tire changing work, it was problematic if the slower cars such as Marmons, Lozier, Benz and Mercedes, with fewer tire changes, would not win out. Everybody took a new view of the race at this point. The honor of the fastest lap went to Eddie Hearne in his Benz, his time being 13:15, his fastest lap so far, and a speed of 77.9 miles per hour. Few knew what Hearne could do with his car. He started last of the foreign group, being slowest in the first circuit, but in four laps he jumped into second place and showed that he had a car as fast as the De Palma Mercedes. It might be said that at the end of this lap there were seven strugglers in the lead and all



The winning Fiat negotiating the turn from Waters avenue



The Bergdoll Benz went out on the eighth lap with gear trouble

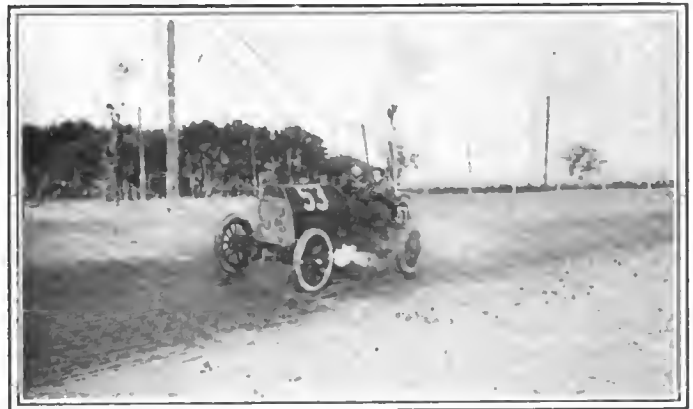

Caleb Bragg drove Fiat 53 to a consistent race



De Palma's Mercedes on the Waters road at 80 miles an hour

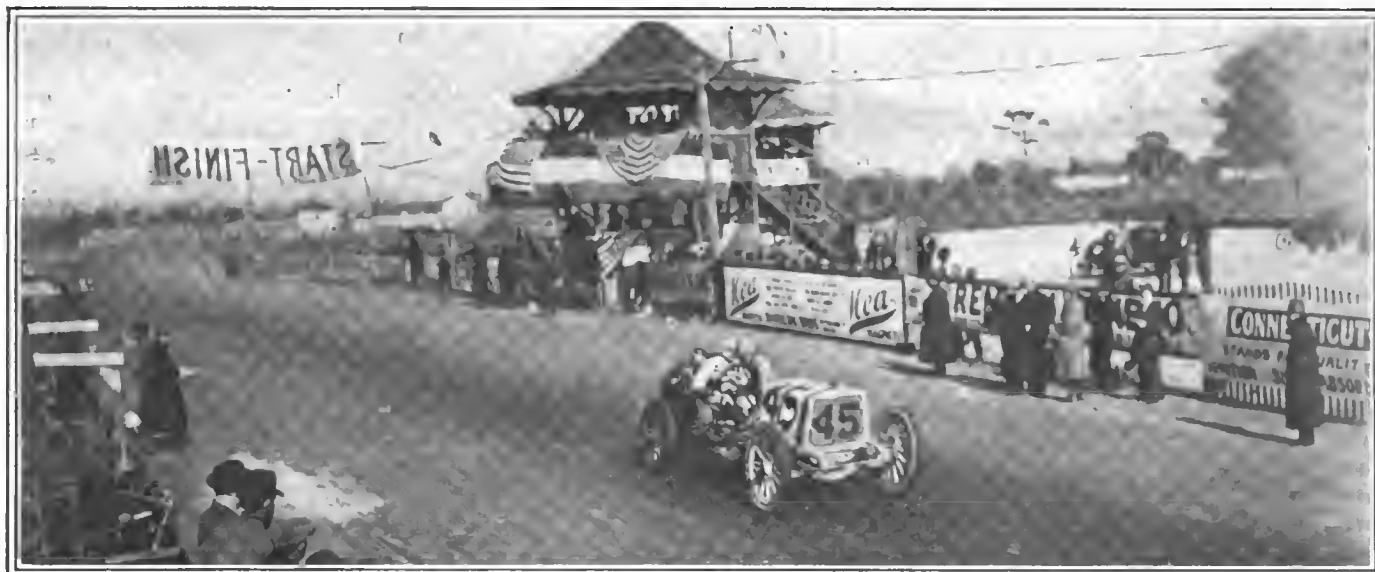

Scene on the homestretch in the nineteenth lap, when Mulford's Lozier was within a few seconds of the lead

within 2 minutes of each other. De Palma, the first of the seven, had made the four laps in 53:08 and Wagner, the slowest, in 55:32. Brown's Fiat was not reckoned in this group as its time was 58:31, but a few seconds ahead of Basle's Buick and the Pope. In this lap Hemery limped past the grand stand and drew off to the side of the road to change a new exhaust valve. He was over an hour in making the third circuit and 47 minutes in the fourth, so that he was nearly 1 1-2 hours back of the leader and out of the race, excepting that he announced he was going to make a repair and go after the fastest lap. Wishart with his Mercedes was now 1-2 hour back of the leaders, and there was 11 minutes between the first and the last of the thirteen cars that were running steadily at this point.

Lap 5—This was an unfortunate lap for American representation as it saw Burman's Marmon drop out when it was running in fourth place and leading the American representation by a matter of 32 seconds over Mulford and Patschke who had tied in lap four at 54:56. When Burman fell out Mulford took up his scepter, having gained 4 seconds on his rival, Patschke, in the fifth circuit. The remainder of the Americans, namely, Buick, Pope and the two Abbots, were running in this order, the same as from the opening lap. The home representation had now dropped from eight to six, with Mulford and Patschke to look after the fast Italian and German cars. The end of this lap saw Hearne in the lead, having got ahead of De Palma who had trouble with a leak in the gasoline line which compelled him to use an auxiliary gasoline line that he already had attached. Hearne now led with a margin of but 29 seconds over Bragg; and Mulford and Patschke were not 2 minutes behind. Then came Wagner, Bergdoll and Brown. Brown was 6 minutes back of Hearne. Hemery fulfilled his previous announcement of going after the fastest lap of the race and he won it, doing the circuit in 12:36 or a speed of 81.6 miles per hour, the fastest official lap ever made on the course. He drove with all his old-time fearlessness. He took all of the turns very fast. When he shot into the homestretch everybody saw by his tremendous speed that he was after the coveted mark. He was slow in shutting down for the grandstand curve and struck it at apparently 70 miles per hour. Entering the turn he held close to the inside, but the momentum of the car was too great to hold it and he skidded wide, almost to the upper side of the bank. He soon straightened up and roared past the grandstand. His skid was the only really bad one made by any of the big cars on the turn, and the hundreds in the grandstand who wanted to see such a performance were satisfied. Bragg sustained his previous reputation by making the second fastest lap in 12:58, the only other one to get under the 13-minute mark. His pace was 79.3 miles per hour.

Lap 6—There was a general changing of positions in this lap, Hearne retaining the lead, but being about the only one of the leaders to hold his place. He had a lead of only 50 seconds on De Palma and but little over a minute on Patschke, Mulford and Wagner. The two Fiat drivers, Wagner and Brown, were closing the gap between them and Hearne, both doing the lap in several seconds under Hearne. Patschke and Mulford were third and fifth, disputing every inch of the course with De Palma and Wagner who was running a little slower than in the early laps and apparently taking more care of his tires. Brown made the lap in 8 seconds less than Hearne, but Wagner had the fastest circuit of the lap in 13:00, 79.1 miles per hour.

### Marmon Takes the Lead

Laps 7 and 8—These were the brilliant laps for the American contenders, because Cyrus Patschke put his Marmon racer to the front and led the entire field—the only two laps in which the American colors led—but unfortunately the pace he set was apparently too strenuous, for he withdrew in the ninth lap, leaving Mulford to do the fighting single-handed against the five foreigner drivers who along with Mulford were making the race at this time. At this point Bruce-Brown was not very much in the limelight. He was still back in sixth place, not having recovered from that terrible setback in the fourth lap. But he was slowly coming out of the darkness, doing laps in 30 to 40 seconds lower than Mulford and Hearne. The seventh was a bad lap for Hearne. He had tire troubles, made a slow lap in 15:14, but hung onto second place by 7 seconds over Mulford and Bragg, who were tied for third place. At this point the positions were: Patschke, Marmon, 94:55; Hearne, Benz, 95:30; Mulford, Lozier, 95:37; Bragg, Fiat, 95:37; Wagner, Fiat, 96:42; Brown, Fiat, 98:38; De Palma, Mercedes, 99:29.

These were the fighting seven, the other seven trailing along far behind and practically out of the race. De Palma had fallen from second place in the sixth to sixth place in the seventh due to his gasoline lead. This advanced all of the other racer one place. The first four were not separated by a minute at the end of lap seven or 120 miles, good proof of the desperate struggle that was taking place. Lap eight was a duplicate of lap seven, excepting that Wagner climbed above his team mate Bragg by a lap in 12:55 or 79.6 miles per hour. This lap marked the start of Bragg's bad luck. An oil lead at the forward end of the motor broke, due to the vibration. It was a hard place in which to make a repair and he blistered his hands in doing the work. He also had to make a tire change on the course and stopped at the grandstand to take on a new shoe. Brown gained from 9 to 10 seconds on Mulford and Hearne in the circuit.



Hemery finally withdrew at the end of the eighth circuit with valve trouble. Wishart also withdrew his Mercedes, due to a cracked waterjacket.

Lap 9—The field was now down to ten machines, five American and five foreign contenders with the race not half over. Of these ten, the first six were making the race, the order at the end of this lap being Hearne, Wagner, Mulford, Bragg, Brown and De Palma with only 4.5 minutes between the first and the last. The three Fiats made the fastest laps, 12:48, 12:53 and 13:03. They were 1-2 minute faster than any of the others in the lap and so everybody wondered if the Fiat colors would again come into the lead, they having been in the background since the third lap.

Lap 10—Hearne increased his lead on Wagner who stopped for oil and gasoline and also changed tires, making his lap a slow one, 14:31, as compared with 13:20 by Hearne. But Brown, though down in fourth place, was traveling fast. He reeled the lap off in 12:48, over 80 miles an hour, and was scarcely 2 minutes behind the leader at this point. He was steadily gaining. De Palma stopped 3 minutes and 30 seconds for gasoline and oil as well as to change a right rear tire and so found himself dropped from third to fifth place. Basle, who had been running in seventh place, dropped out due to engine troubles.

### Looked Like Hearne Victory

Laps 11 and 12—Lap eleven saw Hearne running steadily in the lead with Fiats second and third and 4 minutes behind him, Wagner and Brown being the chasers. De Palma and Mulford were close up but Bragg was 10 minutes in the background. In lap twelve the positions were the same as in lap eleven, this being about the only case of two successive laps in the race in which positions did not change, with the exception of lap twenty-four, in which they were the same as in lap twenty-three. Hearne's time was the fastest in lap eleven, it being 13:22. Hearne led in lap twelve, but stopped 2 minutes 35 seconds for gasoline and oil and tires. Wagner and Bragg made the fastest circuits, doing close to 80 miles an hour. There was now an interval of 36 minutes between the leader Hearne and Mitchell's Abbott. Through all of these laps the Pope-Hummer, piloted by Disbrow, and the two Abbott-Detroits were showing their dogged consistency, going lap after lap at a steady pace. Disbrow was making nearly all of his circuits in 14:38, and the two Abbott-Detroits about a minute to the lap slower. With the race half over Hearne had a lead of 3 minutes on Wagner's Fiat and 4 minutes on Brown's Fiat. He was 5 minutes ahead of De Palma in the Mercedes and 5.5 minutes lead on Mulford. He seemed to be in a safe position, excepting that it was known the Fiats

could make faster laps than he, and if he had good fortune and the Fiats met with tire troubles he would certainly win.

Lap 13—It was in the start of this lap that Hearne had stopped for fuel and made a very slow lap, 16:16. Brown put his Fiat around the circuit in 13:12 and so cut off 3 minutes of the 4-minute lead Hearne had enjoyed. The five leaders, Hearne, Brown, Wagner, De Palma and Mulford, now were more closely bunched than at any other time since the start. It was proving a wonderful race. Hearne was just a minute ahead of Brown. Brown was only 21 seconds ahead of his team mate, Wagner, De Palma was but a minute back and Mulford 1-2 minute behind De Palma. It was now anybody's race. These battlers were almost 20 minutes ahead of the Pope and the Abbotts. Brown was now second and only a minute from leadership. All expected him to cut that minute off in the next lap and take the lead from Hearne who had held it for five successive laps.

Lap 14—The unexpected happened. Instead of taking the lead from Hearne, Brown stopped for tires, was stopped 1 minute 20 seconds at the pit and found himself fifth or last in the bunch of leaders. Never before was there such a five-sided duel. It meant but a tire change to alter the entire state of affairs. A mere stop of less than 2 minutes made the first last and the last first. Wagner was the hero of the lap, making the circuit in 12:48 at a speed of 80.3 miles an hour. It put him in second place, only 24 seconds back of Hearne. He now was looked upon as the leader in the following lap. De Palma and Mulford were 2 minutes back of Wagner and Brown a minute behind them.

Lap 15—This lap was unlucky for the Fiats as Wagner was eliminated. His 80-mile pace of the previous lap was too much. He tried to duplicate in this circuit but overran a turn. Nobody knows exactly what did happen. But the rear axle was a little sprung and the steering out of commission. He drove to the grandstand and withdrew. This left but four leaders in the real fight, as Bragg was 12 minutes behind the group and he was in turn 10 minutes up on the Pope and 20 and 25 minutes on the Abbott. There were yet nine laps to go and the leaders stood in this order: Hearne, Benz, 206:57; De Palma, Mercedes, 208:00; Mulford, Lozier, 208:28; Brown, Fiat, 208:31. There was not 2 minutes between the first and the last.

Lap 16—This lap worked an upheaval; Brown passed both Mulford and De Palma and got in second place just 1 minute 25 seconds back of Hearne, almost as close to him as he had been three laps before. Brown was driving conservatively. For the last five laps he was making circuits in 13:12 or thereabouts, which averaged 30 seconds to the lap better than Hearne and apparently he had settled down to get into the lead by this kind of driving rather than by the terrific speeds that put Wagner out



Hearne's Benz passing Limberg's Abbott-Detroit on the wide curve leading from the Waters road



and also caused the oiling troubles on Bragg's Fiat. It was now really a single-handed fight among the Benz, Fiat, Lozier and Mercedes. Mulford, who started single-handed, was still in the ring; De Palma had lost his running mate in the ninth lap and both of Hearne's supporters were gone. It was now a real fight, and with the Fiat cutting the frills out the race was taking on a new aspect. It was real business and not sensationalism.

Lap 17—The great fight in this lap was between Hearne and Mulford, Hearne having the lead by only 27 seconds. Brown met with tire troubles and went slowly in 15:26, practically 2 minutes slower than the other three. Bragg was now running in fine shape but 15 minutes behind this group.

Laps 18 and 19—These two laps were races, the order being Hearne in the Benz, Mulford in the Lozier, Brown in the Fiat and De Palma in the Mercedes. Brown made each of these laps in 30 seconds under the other drivers and so found himself at the end of lap nineteen but 43 seconds from first place, the closest he had been from the start of the race. Hearne still led with Mulford second. This was the standing: Hearne, Benz, 263:03; Mulford, Lozier, 263:18; Brown, Fiat, 263:46; De Palma, Mercedes, 267:25. De Palma had lost his time on changing tires.

Lap 20—Brown leads. This was shouted everywhere, and for the first time the winner of the Grand Prize last year was able to put the Fiat colors to the front since the third lap when Bragg had placed them there. Yes, Brown led and led with but four laps to go. But his lead was only 14 seconds on Mulford and 31 seconds on Hearne. Brown gained his place by fast traveling, doing the circuit in 13:18, as compared with 14:00 by Mulford and 14:32 by Hearne.

Lap 21—The struggle continued, Brown increased his lead from 14 seconds to 36 seconds over Hearne and was over a minute ahead of Mulford. De Palma was 4 minutes back.

Lap 22—The end of this lap saw the most intense moment ever witnessed in a road race. It saw all three racers, Brown's Fiat, Hearne's Benz and Mulford's Lozier, stop at the pits together and with but two more laps to go. A driver will not stop at such an important time unless there is a reason. Brown was

first into the stretch in sight of the grandstand. He was cheered to the echo. He slowed into the turn. "He is stopping" was heard on every hand. Back of him raced Mulford. He slowed also and stopped. The entire grandstand was on its feet. Scarcely was he at the pits than Hearne rounded the turn and stopped. Brown was 1 minute and 8 seconds changing a left rear tire; Mulford was 36 seconds taking on some gasoline, and Hearne was 1 minute changing a right rear tire. Many at the Lozier pit did not want Mulford to stop, but he had been signalled the previous lap to stop for fuel and did not take any chances. Many in the Benz pit thought Hearne should not have stopped, but it seems that he was fatigued from the long grind and would not take any chances with a poor tire on the turns. Mulford was first away. He dropped into second and shot off. Brown was hot after him and Hearne was last. According to the official figures, Hearne led for the lap. His time was 304:42; Mulford's time was 305:08, and Brown's 305:24. Brown was last, which was due to the fact that he did not cross the tape before repairing his tire whereas Hearne and Mulford did.

Laps 23 and 24—These were fatal to American interests. Scarcely had Mulford started on lap twenty-three when he went out of the running by twisting the clutch off the outer end of the axle-drive shaft. In taking a street-crossing the car bounded into the air and when the back wheel struck the ground the engine speed up and the car slowed down. Mulford knew the trouble and pulled to the side of the road. The remainder was a procession. Brown was leading. At the end of the twenty-third lap when he got the green flag he was 1 minute 30 seconds ahead of Hearne. Nothing but tires could stop him. The lap was a fast one, too, the time being 12:53 or nearly 80 miles per hour. De Palma was 3 minutes behind. In the last or twenty-fourth lap, Brown slowed down to 13:12, still 1-2 minute faster than Hearne, but only a couple of seconds faster than De Palma made the circuit. At this time Brown was laps ahead of the Pope and the two Abbott-Detroits. He was 50 minutes ahead of Disbrow and an hour ahead of the leading Abbott, all of which were lower-powered cars.

## KlineKars Win Handily at York

YORK, PA, Dec. 1—KlineKars finished as winners yesterday afternoon in five of the seven events in which they were entered in the meet of the South Jersey Motor Club, on the York fair ground track. The track record for five miles was twice broken and a new record for one mile established. About 1,000 persons witnessed the races.

The first track record was broken in the third event, when the five-mile time was lowered by a KlineKar to 6:46 3-4 from 7:07. The best mile of the five was made in 1:24. The same car driven by Menker in the special handicap again established a new record, doing the five miles in 6:25 1-4.

Four events were omitted from the program, which originally included ten. These were the special handicaps for winners and losers, the time trials and the second heat of the division 20 class. For the time trials there was substituted a special handicap race between an Abbott-Detroit car driven by Padula and a Mercer driven by Ringler.

The event between Padula and Ringler provided a fast and exciting race. Ringler had his opponents' handicap of 20 seconds well made up by the sixth heat, but waited for the last mile before going in to win. Then, at full speed and taking the turns in a faultless manner, he closed up on the Abbott racer and beat Padula to the tape. The summary:

Car	Driver	Position	Time
KlineKar	Menker	1	7:37 3/4
Abbott-Detroit	Padula	2	.....
Buick	Haupt	3	.....

5-mile Non-Stock			
Car	Driver	Position	Time
KlineKar	Menker	1	7:25 1/2
Mercer	Ringler	2	.....
Knox	Di Napoli	3	.....
5-mile Non-Stock			
KlineKar	Menker	1	6:46 3/4
Mercer	Ringler	2	.....
Knox	Di Napoli	3	.....
5-mile Non-Stock			
Abbott-Detroit	Padula	1	7:23 1/2
Buick	Lambright	2	.....
5-mile Special Handicap			
Mercer	Ringler	1	7:03 1/2
Abbott-Detroit	Padula	2	.....
5-mile Non-Stock			
KlineKar	Menker	1	7:21 1/2
Knox	Di Napoli	2	.....
5-mile Special Handicap			
KlineKar	Menker	1	.....
Mercer	Ringler	2	.....
KlineKar	Sechrist	3	.....
Abbott-Detroit	Padula	4	.....
Buick	Haupt	5	.....
Buick	Lambright	6	.....
Knox	Di Napoli	7	.....

### Loziers Are Shaft-Driven Cars

In last week's issue of THE AUTOMOBILE, in the story of the Vanderbilt race, the statement was made that "the Loziers are chain-driven machines," etc. Of course every well-posted automobilist knows that the car that won the Vanderbilt is shaft-driven. The car to which the writer had reference was the Mercedes, but through an unaccountable error the name Lozier was substituted.

# News of Shows, National and Local



REVELATION in the decorating of automobile shows is promised at the twelfth national automobile show in Madison Square Garden, January 6 to 20. For several months past those in charge of the show have busied themselves producing a proper setting for the motor cars, motorcycles and accessories and no expense is to be spared to make the setting the most attractive ever seen in the historic building. Not only in the matter of decoration but in every other detail is the show committee striving to eclipse all former exhibitions. As this is to be the last automobile show to

be held in the Garden, old patrons are assured of witnessing a spectacle which is bound to be lasting in their memory. As usual, the full description of the decorative scheme has been withheld by the show committee because of minor changes but it will soon be released. The Garden interior this year will be richer and more magnificent than for any previous affair, although perhaps more refined in treatment.

## Partial M. & A. M. Show Program

Announcement has been made of a partial program for the Motor and Accessory Manufacturers during the approaching show season in New York. The annual meeting will be held at the Waldorf-Astoria, commencing January 10 at 10:30 a. m. The feature of this meeting will be the election of four directors. There is no well defined policy of succession in office in the M. A. M. and consequently the personnel of the official roster is uncertain.

The annual banquet, reputed to be one of the most elaborate of the metropolitan show season will be held at the Waldorf-Astoria, January 11, at 7 o'clock.

In addition to the big showing of the members of the association at the Madison Square Garden exhibition, it has been announced that twenty-eight of the members will show at Grand Central Palace.

The following new entries have been received by the Motor & Accessory Manufacturers, for the exhibitions arranged by the management:

For Madison Square Garden, for both weeks: Warner Instrument Co., Beloit, Wis.; first week only: Detroit Electric Appliance Co., Detroit, Mich.; Noera Manufacturing Co., Waterbury, Conn.

For Chicago show, both weeks: R. E. Hardey Co., Chicago, Ill.; Texas Co., New York City; U. S. Tire Co., New York City; first week only: Chicago Telephone & Supply Co., Chicago, Ill.; W. F. Spocke Machine Co., Indianapolis, Ind.; Standard Thermometer Co., Boston, Mass.; Hess Springs & Axle Co., Carthage, Ohio.

## Denver Space Almost All Gone

DENVER, Dec. 4—Definite arrangements for the annual Denver automobile show have been completed and under the auspices of *Motor Field* of this city the big event will be held at the

Auditorium March 4 to 9. Already 14,500 of the 15,100 available feet of floor space has been assigned and it is expected that within the next week the allotments will be exhausted. Lively interest is being shown in the enterprise by the local dealers and it is expected that the Spring trade will show a decided advance over the slack fall business as a result of the attractive displays which will be made.

An effort toward building up the motor truck trade in Colorado will be made. One day will be designated as Motor Truck Day and rural dealers who have territory that is considered especially open to truck sales will be invited as guests of the management.

## Importers Draw for Salon Space

Drawings for space at the coming show of the importers was held yesterday afternoon at the Hotel Astor. The show will open January 2 in the banquet hall of the hotel, occupying the same quarters as last year. Among the cars to be exhibited are the following: Renault, Itala, Isotta, Minerva, Opel, Benz, C. G. V., Darracq, DeDion, Napier, Picric, S. P. A., Metalurgique, Lancia and Mercedes.

## Other Shows in Prospect

TOLEDO, O., Dec. 4—Toledo will have an automobile show this winter according to the plans which were definitely evolved this week. The show will be given under the direction of the Toledo Automobile Dealers' Association, January 15 to 20 inclusive and will be held in the large terminal railway building on Cherry street. It has been determined that the entire management of the exposition shall be placed in charge of Hugo V. Buelow, of Detroit, an expert in this line of work. The entire ceiling of the exhibition building will be of trellis, the walls will be covered with light blue bunting with a heavy flounce of old gold color. A carload of Southern smilax has been ordered from Alabama, 20,000 artificial roses will be made up, a large number of paintings to adorn the walls, statuary costing \$5,000 and 10,000 incandescent lights will add to the beauty of the structure.

DAVENPORT, IA., Dec. 4—The directors of the Davenport Automobile Association have set the date for the annual automobile show on Feb. 28-March 2, which places the local exhibit between the St. Louis and Des Moines shows and thus enables dealers to arrange for exhibits at all three. This year the show date does not conflict with the Chicago Truck Show as it did last year. Half of the display this season will be trucks.

ROCHESTER, N. Y., Dec. 4—The Rochester Automobile Dealers' Association will hold its annual automobile show the week of January 22-27 in the State Armory. Pleasure cars, commercial vehicles and accessories will be shown. Great interest is being manifested by the public as well as by the dealers and a most successful exhibition is expected.

Detroit, Mich., Dec. 4—At the second and final drawing for space for the 1912 Detroit automobile show, held in the offices of the Detroit Automobile Dealers' Association last week, the remaining 4,000 square feet of floor space was distributed among 13 independent concerns as follows: Oakland Motor Car Co., Anderson Carriage Co., Krit Motor Car Co., the Marquette Co., the Motor Wagon Co., W. A. Patterson, of Flint, Mich., the Hupp Corporation, Flanders Manufacturing Co., Commerce Motor Car Co., C. S. Briggs, showing his new "Detroitter," the Churchfield Motor Co., of Sibley, Mich.; the Miller Car Co. and the Grinnell Electric Co. An unusually elaborate decorative scheme is being worked out. The work will be performed by one of the largest decorating concerns in the United States.

## Résumé of the 1911 Racing Season

**N**EW racing records were made in all departments of contest work in the automobile season of 1911. On beach, track, road, hill and speedway the flyers traveled faster than they ever had before. A new set of world speed marks was established in several of the classes.

The season of 1911 proves that the art of manufacturing automobiles is more perfect than it has been in the past, and the proof may be briefly cited from the single fact that the wonderful time

mighty few of them. This season the winning cars have had more margin, but in no case except the Fairmount Park race was the victory what may be termed hollow. Even then only about 3 minutes separated the first two cars.

The season has been strange from the rising of the curtain until its final drop. Starting off with the promise of an organized racing circuit to insure good fields and skilled administration for the speed events to be held in all the racing centers, the pro-



1—Herrick in the National, making new American road record at Santa Monica. 2—Wilcox in the National, breaking the record in the Dead Horse hill climb. 3—Ray Harroun, speedway champion of the world. 4—David Bruce-Brown, winner of the Grand Prize. 5—Witt, who created new 161-230 and under-160 records with E-M-F and Flanders.

made by a Fiat car over the 30-mile Florio road course in Italy several years ago was beaten this year by one or two American-made cars, approximately stock models, over shorter circuits.

On the speedways of Indianapolis and Los Angeles some remarkable performances were accomplished.

Dirt-track racing, while much less popular than before, showed decided progress in speed, while on the hills the general average of performance was much better than in 1910. Beach racing also demonstrated its value as never before.

The features of the 1911 season were the road races for stock cars and special racing machines. The stock cars only performed as such in one big meeting, while the special cars showed their paces in six major events.

Hairline finishes that marked the running of most of the big races in 1910 were absent this season. In 1910 the Fairmount Park, Vanderbilt Cup and Grand Prize were won by seconds and

gram flattened out and for a while it seemed that the knell of racing had been rung. The grand circuit idea found no favor with the manufacturers and under the circumstances it is remarkable that the Indianapolis race held May 30 proved to be such a popular event.

This race was the longest and hardest contest for automobiles ever staged on a special speedway. It attracted the largest and most varied field of entries that ever faced a starter and the largest paid attendance in the history of the sport. It was a marvelous race won by a six-cylinder Marmon car accurately handled by Harroun in his only major start of the year, assisted by Patschke with some great speed work.

The world's speed record in a road race was established October 14 in the annual Santa Monica road race at Los Angeles, when a National car driven by Herrick averaged 74.628 miles in an hour for 202.08 miles. The record made by the National in

this event stands as the official mark for a completed race, but the time made by the car for 202 miles has been exceeded twice. The Lozier car in winning the Vanderbilt Cup averaged a fraction more per hour and the Benz car that finished second in the Grand Prize made 76.2 miles an hour for twelve laps. But these marks are at best intermediate records and as the figures show the rate of speed made over the shorter distance was not maintained.

The Fairmount Park race is always much slower than any of the other big events because of the numerous dangerous curves and grades, but in this year's running of the event the course record was broken by a Benz car driven by Erwin Bergdoll. The new mark set is 61.149 miles an hour, almost 13 1-2 miles an hour slower than the record performance of the National at Santa Monica. This race was run in four classes, each being considered a race in itself.

The Elgin national stock car races proved victories for the

These were divided under five heads: Track, hill-climbs, road races, speedway events and beach races. There were 207 races run on circular dirt tracks at various points in the country, but largely centered in the district near New York City.

The tabulation under this head shows that the Simplex won more dirt track races than any other make of automobile. The figures might be somewhat confusing unless it is remembered that Ralph De Palma campaigned a powerful Simplex car most of the past season, winning race after race with it against small fields. This should not detract from the performance of the car, but due weight should be given to the fact that the showing of the Simplex on the dirt tracks was to a considerable extent based upon the work of one car.

The Mercer is second in this table with 20 winning races. Hughes, the factory driver, raced Mercers at track meets with much success, but the high standing of the car in the list is due

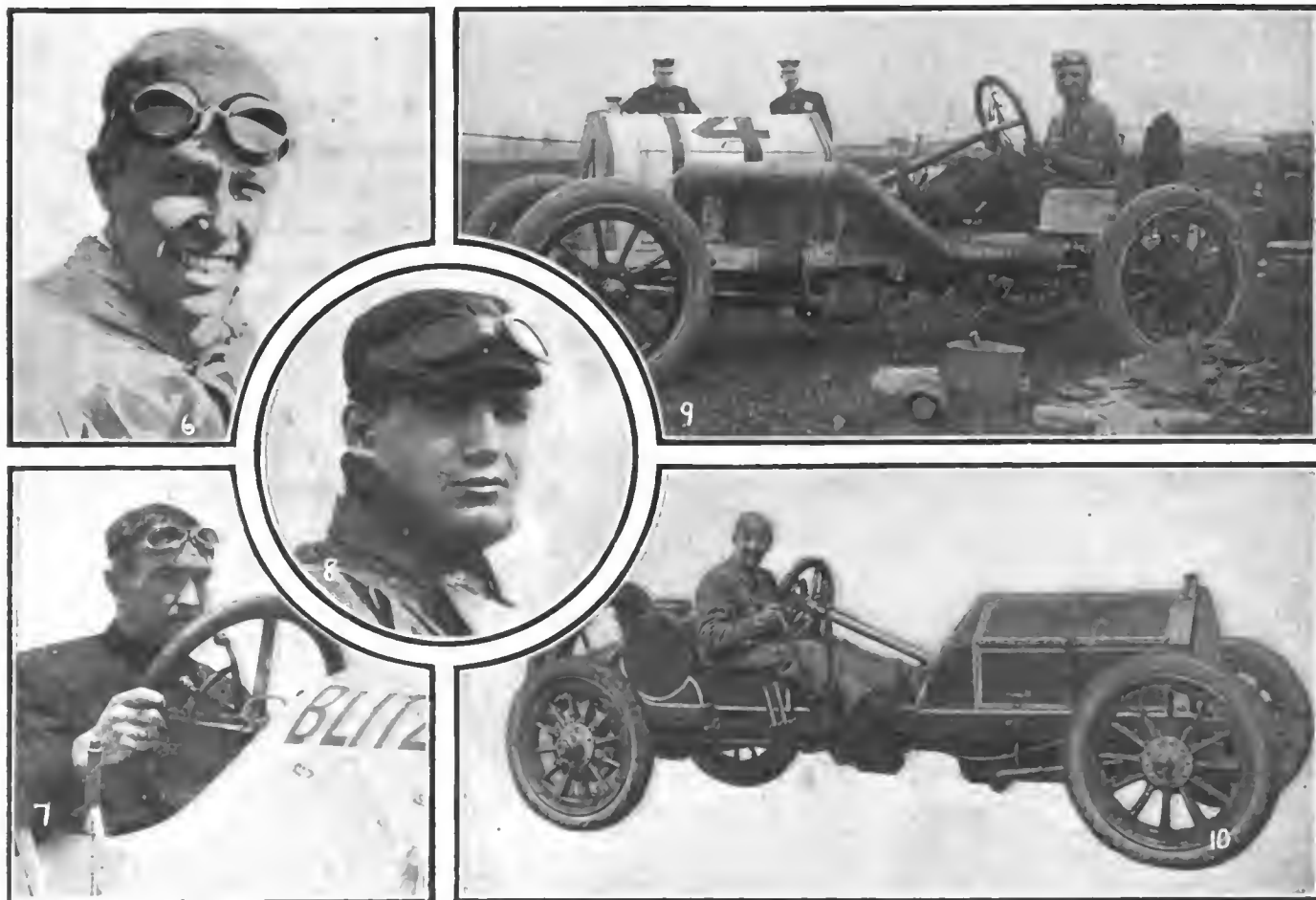

6—Ralph Mulford, this year's Vanderbilt winner. 7—Bob Burman, who drove the Benz and Opel to new records. 8—Ralph De Palma, competition champion of the year. 9—J. R. Rainey in the Cino, a winning combination. 10—Hughie Hughes, who drove the Mercer to many victories on track and road.

National in the two large classes and the Mercer and Abbott-Detroit in the smaller divisions.

But the climax of the season was the meeting at Savannah, where four great contests were decided. The winning Fiat, Lozier, Mercer and E-M-F established new marks in their various divisions. The performance of each was of the highest character. The Vanderbilt Cup winner closely approached and the victor in the Grand Prize race went faster than the old Florio record, while the showing of the smaller cars was much better than the existing records, for their classes and the distances run up to the time of the running of the races.

All told during the season of 1911 there were 361 contests decided of a major character. These were all duly sanctioned and officially administered. Of course there were more races run that were important locally and sanctioned, but in the following tabulation only the more important events are considered.

not only to the winning races in which Hughes drove, for Harvey Ringler, of Philadelphia, also contributed several wins to the total. The National and Cino are tied for third place in the standing with 18 victories each. The Cino victories were largely scored around Cincinnati, but Nationals raced all over.

The Benz, Buick, E-M-F, Case, Velie, Abbott, Staver, Interstate and Opel made creditable showings. The latter was returned winner in five races along toward the close of the season and proved to be one of the speed sensations of the racing season.

One of the saddest angles in track racing is the showing made by a number of heaps of junk that masqueraded under the names of various well-known factories. For instance, a Peerless of 1906 was raced against other cars of current model; a Marmon that had once been a flyer, but which had outlived its usefulness, made a pitiful showing against cars that would have been easy

for it in another day. Numerous other factories that take no interest in racing were pained to learn in the press that old cars bearing their names had finished out of the money and behind cars that would have proved easy for current models.

In hill-climbing there were 71 races run of sufficient importance to tabulate. The National cars won 23 firsts, most of the victories being scored by the factory team, although a few private owners and district agents added to the total. The Ford and Buick tied for second with the Oakland and Knox next in order. As a general proposition the time made over the various hills negotiated was better than it was in 1910.

There were 25 road races during the season, counting as races

**Characteristic American Racing Scenes**



How Indianapolis Speedway looks on a racing day



Ideal hill-climb scene—stock car event at Algonquin

the performances of the various divisions of Classes B and C. The National won eight firsts, Mercer four, Fiat, Lozier and Buick two each and the remainder were divided among seven different makes.

On the speedways the National also led with five victories, but was closely pressed by the Simplex. The performance of the Marmon at Indianapolis was the most notable feat of the year on the speedways, but the Fiat made a wonderful showing in the 24-hour race run at Los Angeles where it turned 1,491 miles. On the beaches the National won 17 times.

Grouping all the contests it is found that the National leads by an overwhelming number of victories, scoring 72 wins during

the season. In total number of victories this make stands first in each division except dirt track racing. The nearest competitors of the blue cars were the Mercers and Simplexes, with 30 wins each.

Buick, Ford, Cino, Benz and E-M-F are next in line and then follow the remainder of the 52 makes that took part in the racing of the year to the extent of at least one first.

**How the Cars Performed**

Road Races								
Make	1st	2d	3d	Make	1st	2d	3d	
National	8	2	3	Pope	1	4	2	
Mercer	4	1	4	Benz	1	1	0	
Buick	2	0	0	E-M-F	1	2	2	
Lozier	2	0	0	Abbott	1	0	0	
Fiat	2	0	1	Cole	1	1	0	
Marmon	1	3	2	Ford	1	0	0	

Speedway Races								
Make	1st	2d	3d	Make	1st	2d	3d	
National	5	7	2	Marmon	1	0	1	
Simplex	4	2	1	Knox	1	0	1	
Lozier	1	1	0	Fiat	1	0	0	

Beach Races								
Make	1st	2d	3d	Make	1st	2d	3d	
National	17	10	7	Ford	2	0	0	
Pope	7	9	9	Cadillac	2	0	0	
Warren	3	2	0	Lancia	1	1	2	
Mercer	3	2	1	Buick	1	2	2	
Cole	3	5	4	E-M-F	1	0	0	
Benz	2	0	0	Inter-State	1	2	3	

Hill Climbs								
Make	1st	2d	3d	Make	1st	2d	3d	
National	23	10	5	Fiat	2	1	1	
Ford	9	6	3	Marmon	1	1	1	
Buick	9	10	5	Staver	1	1	0	
Oakland	6	3	0	Flanders	1	0	0	
Knox	5	8	4	Abbott	1	2	0	
Velie	3	2	6	Falcar	1	1	0	
Empire	3	3	0	Benz	1	0	1	
Corbin	3	0	0	Simplex	1	2	1	
Mercer	3	2	2	Faige-Detroit	1	1	0	
Pope	2	1	3	S. P. O.	1	0	0	
Cino	2	1	0	Everitt	1	0	0	
Cole	2	4	1	Stoddard-Dayton	1	0	0	
Lion	2	0	0	Reo	1	0	1	
Case	2	2	1	Metz	1	1	3	
Krit	2	1	0					

**Contest Records**

Driver	1st	2d	3d	Driver	1st	2d	3d
De Palma	32	4	6	O'Brien	2	0	1
Burman	22	6	0	Maisonville	2	3	7
Wilcox	18	12	3	Aitken	2	1	1
Hughes	15	12	4	Belcher	2	5	2
Raimy	15	4	5	Heitmyer	2	0	0
Zengel	12	1	0	Boersch	2	1	3
Tower	12	3	3	Knipper	2	6	0
Kulick	10	4	2	Farr	2	0	1
Disbrow	9	16	11	Nielsen	2	1	0
Ringler	8	1	0	Bishop	2	0	1
Bauer	6	1	0	Apgar	2	0	0
Jagersburger	6	4	3	Tucker	2	1	0
Merz	6	3	5	Foutz	2	1	1
Herr	5	0	0	Walker	2	1	1
Davis	5	0	0	Menker	2	0	0
Rutherford	5	5	1	Redewell	2	1	0
Nikrent	5	3	5	Robinson	2	0	1
Dingley	4	4	0	Heisey	2	0	4
Bragg	4	1	1	Mulford	2	0	0
Pearce	4	4	1	Hearne	2	4	1
Sutherland	4	1	0	Smith	2	1	1
Herrick	4	0	0	Paischke	2	1	1
Monckmeier	4	8	5	Sheets	2	2	5
M. Roberts	4	5	1	Ireland	2	0	0
Bruce Brown	3	0	0	Radina	2	0	0
Seck	3	1	1	Padula	2	3	0
Peterson	3	0	0	Hoffman	2	0	0
Witt	3	0	0	De Witt	2	0	0
Jenkins	3	3	0	Reeves	2	0	1
Heineman	3	5	3	Clark	2	0	0
Coffey	3	4	2	Wilson	2	3	2
Donnelly	3	6	3	Pieling	1	0	0

There were seven makes of foreign cars in American racing in 1911. These were Benz, Fiat, Opel, Mercedes, S. P. O., Hotchkiss and Lancia. The latter concern was represented by a single old car which failed to gain any appreciable laurels. The first three named raced the best product of their factories and there were two Mercedes cars in American contest work that would rank high anywhere.



Coming down to the drivers, the tabulation shows that Ralph De Palma won 32 events, leading Burman by 10 victories. De Palma drove Simplex, Mercer, Fiat and Mercedes cars, winning mostly on a Simplex driven on dirt tracks.

Burman drove Benz, Opel, Mercedes and Marmon cars, scoring most often with the first named. In Wilcox, Zengel, Merz, Herr and Herrick the National factory was well off for pilots,

test he is regarded as being a leader. His specialty, however, is driving in endurance and reliability runs. Raimey, driver of the Cino, made an excellent showing in the winning column.

Bruce-Brown, winner of the Grand Prize, only started a few times during the year, but his work showed that he had forgotten nothing of his knowledge of driving. Harroun only started in one real race, the 500-mile international sweepstakes at Indianapolis, and won it. Mulford also was an infrequent starter, but he won his class in the Fairmount Park race, finishing second to the Bergdoll Benz. He also won the Vanderbilt Cup race.

Frank Witt, who drove the winning E-M-F in the Tiedeman Trophy race, made only a few starts during 1911, and the same

## During the Year

Track Events			
Make	1st	2d	3d
Simplex	25	4	5
Mercer	20	11	6
National	18	16	13
Cino	18	9	8
Buick	16	9	12
Benz	13	8	2
E-M-F	13	6	8
Ford	11	3	1
Case	7	8	6
Velie	7	2	2
Abbott	5	6	2
Staver	5	10	8
Inter-State	5	2	1
Opel	5	1	0
Colby	4	1	0
Klinekar	4	6	1
Firestone-Columbus	3	2	1
Mercedes	3	7	1

General Summary			
Make	1st	2d	3d
Pope	3	4	3
Warren	3	5	3
Ohio	2	2	1
Fiat	2	4	1
Cutting	2	4	6
Corbin	2	1	6
Stearns	1	0	0
Midland	1	2	0
Maxwell	1	1	0
Jackson	1	7	4
Hudson	1	1	0
S. P. O.	1	0	2
Hotchkiss	1	0	5
Correja	1	3	0
Chalmers	1	1	3
Paige-Detroit	1	5	5
Marmon	1	7	3
Schacht	1	1	3

Cars of seventeen other makes won a single race or contest each, and finished second twenty-one times and third twenty-two times.

## of the Drivers

Driver	1st	2d	3d	Driver	1st	2d	3d
Wiggins	1	0	0	Rouse	1	3	4
Van Wyck	1	0	0	Ormsby	1	2	0
Du Closne	1	1	1	Kilpatrick	1	0	5
Limberg	1	2	0	Oberting	1	0	1
Stone	1	1	0	Meddock	1	3	0
Grennan	1	0	1	Frayser	1	1	0
Richter	1	1	0	Hilliard	1	0	1
Hahn	1	0	0	Harroun	1	0	0
Falk	1	0	0	Sandell	1	0	0
Welch	1	0	0	Hahieb	1	3	1
Darling	1	0	0	Keene	1	0	0
Meador	1	1	0	Wehr	1	0	0
Wallace	1	1	2	Lawson	1	1	0
Purdy	1	0	0	Maxwell	1	0	0
Forster	1	2	0	Bergdoll	1	0	0
Lame	1	0	0	Parker	1	1	0
McLean	1	0	0	Morton	1	5	2
Dawson	1	0	0	Regan	1	0	0
McMillan	1	0	0	Ficke-bacher	1	0	0
Lanahan	1	0	0	Steinbrugge	1	0	0
Gruener	1	1	0	Schillo	1	0	1
Cooney	1	0	1	Burt	1	0	1
Anderson	1	2	1	Burke	1	2	0
Stickney	1	1	4	Gray	1	1	2
Morris	1	0	0	Koopman	1	2	0
Hotchkiss	1	0	0	Whelan	1	0	2
Craig	1	5	5	Haupt	1	5	1
Hooker	1	0	1	Tremaine	1	0	0
Pennebaker	1	0	0	Cooper	1	2	0
Fritsch	1	0	0	Evans	1	5	0
Tetzlaff	1	0	0				

as shown in the winning tabulation. In Disbrow and Dingley the Pope factory was well represented. The Mercer victories were scored by Hughes and Harvey Ringler. Kulick scored much success and Tower, of the Studebaker team, won many times with the E-M-F and Warren. Howard Bauer, of the Oakland company, had a high percentage of wins in a small number of starts. His performances were mostly hill climbs, at which form of con-

## Characteristic American Racing Scenes



The Elgin course during the National Stock Car Championships



Galveston's beach racing course during the spring meet

may be said for such sterling performers as Belcher, Knipper, Hearne and Bergdoll.

The factory campaign of the National company and the activity of De Palma, Hughes and Raimey in minor events, which count in the totals with the same force as the winning of a big road race, have served to confuse the perspective. On the figures the National is the champion of the year and De Palma is the king-pin driver. Burman is second in the list.

The tendency as shown in 1911 is toward centralization, but on different lines from those suggested by the futile grand circuit fiasco. A speedway near New York is projected and in the Central West is a movement to build a circuit for track racing.

# The Long-Stroke Motor for Cars

## Part II

BY PROFESSOR W. D. ENNIS

**I**N a previous installment of this paper, which appeared in *THE AUTOMOBILE* for November, the writer discussed some of the more evident and obvious factors which should be considered in fixing the ratio of stroke to bore in automobile motors. The present article deals specifically and quantitatively with these and some other more fundamental, if less apparent, factors. The tractive or pulling force exerted by a four-cycle gasoline motor cylinder is compiled from the established formula

$$F = \frac{pd^2sr}{2Nw}, \tag{I}$$

in which

- $F$  = tractive force in pounds per cylinder, at the cylinder;
- $d$  = diameter of piston, in inches;
- $s$  = stroke of piston, in inches;
- $r$  = revolutions per minute of crankshaft;
- $N$  = revolutions per minute of road wheel;
- $w$  = diameter of road wheel in inches;
- $p$  = average pressure continuously maintained in the cylinder: say about 17 for an ordinary cylinder well operated, single-acting.

The tractive force actually available for propelling the machine will be reduced from this by from 15 to 25 per cent. at the motor shaft and by a further, probably approximately constant, amount at the rim of the wheel.

Since the quotient  $\frac{r}{N}$  is what is commonly described as the *gear ratio*, the tractive force for a given car varies directly with the gear ratio. Now, the quantity  $d^2s$  may be written as  $D \div 0.7854$ , where  $D$  is the cubical displacement of the piston per stroke, for  $0.7854 d^2$  is the cross-sectional area of the piston and  $0.7854 d^2s = D$  is its displacement. Equation I then becomes

$$F = \frac{pDr}{0.7854 \times 2 \times N \times w},$$

and if we take  $p = 17$ ,  $\frac{r}{N} = g$ , this gives

$$F = \frac{17 Dg}{0.7854 \times 2 \times w} = \frac{10.82 Dg}{w} \tag{IIa}$$

A 4 x 5-inch cylinder would have a displacement  $D = 0.7854 \times 4 \times 4 \times 5$ ; its tractive force at a 10-to-1 gear would then be  $\frac{10.82 \times 0.7854 \times 4 \times 4 \times 5 \times 10}{32} = 213$  pounds,

if its wheels were 32-inch diameter.

Then the pulling forces, which can be theoretically exerted by *four-cylinder* motors under the assumed conditions, will be as shown in the chart, it being understood that the reductions

**The Engineering Problems of the Long-Stroke Motor Are Discussed in Both Theoretical and Applied Form—Tractive Force is the Real Criterion of a Motor's Value—The Longer the Motor Stroke the Slower the Crankshaft Speed and the More Durable the Engine—Motor Weight Per Horsepower Capacity Is Reduced—Greater Economy in Fuel Is Obtained—More Room for Accessories in the Long-Stroke Motor.**

previously referred to must be made if the results are to correspond with those of practice.

Terms for Tractive Force

Since  $s$  is the stroke in inches,  $\frac{25 s}{12 \times 6}$  is the distance in feet traveled by the piston in one revolution, and  $\frac{rs}{6}$ , which we may call

$S$ , is the piston speed calculated in feet per minute. Then,

$$F = \frac{3pd^2S}{Nw} \tag{II}$$

Also, the circumference of the road wheel is equal, ignoring slipping of tires on road, to the distance traveled by the car in

one revolution, and this is  $\frac{\pi w}{12}$ . In 1 minute the car will move  $\frac{\pi w N}{12}$  feet, or in 1 hour it will travel

$$\frac{\pi w N \times 60}{12 \times 5280} = \frac{wN}{336} \text{ miles,}$$

which speed we may call  $V_0$ .

Then  $V_0 = \frac{wN}{336}$

and

$$F = \frac{pd^2S}{112 V_0} = \frac{pd^2sr}{672 V_0} \tag{III}$$

For  $p = 17$ ,  $F = \frac{d^2S}{6.6 V_0} = \frac{d^2sr}{39.5 V_0}$ ,

and if  $S$  be taken at 1,000,

$$F = \frac{151.5 d^2}{V_0} \tag{IV}$$

This last expression is less general than any of the preceding, but is the simplest form possible, the ideal tractive force being a function of the cylinder diameter and car speed only.

TABLE OF THEORETICAL TRACTIVE FORCES.

Speed of Car, Miles per Hour.	Tractive Forces Per Cylinder, in Pounds, for Cylinder Diameters Stated.									
	4-in.	4¼-in.	4½-in.	4¾-in.	5-in.	5¼-in.	5½-in.	5¾-in.	6-in.	6-in.
5	484	549	611	684	758	836	918	1000	1192	
10	242	274	306	342	379	418	459	500	596	
15	161	182	205	228	252	278	305	333	364	
20	121	137	153	171	189	209	230	250	292	
25	97	110	122	137	152	167	183	200	218	
30	81	91	102	114	126	139	153	167	182	
35	69	78	88	98	108	119	131	143	156	
40	60	68	76	86	94	105	115	125	146	
45	54	61	68	76	84	93	102	111	121	
50	48	55	61	68	76	83	91	100	109	
55	44	50	56	62	69	76	83	91	99	
60	40	45	51	57	63	70	76	83	91	

Equation IV holds only for a piston speed of 1,000 feet per minute, a figure roughly standardized as a basis for rating. The power of any engine may vary directly with its piston speed; the faster it runs, the more work it can do. The tractive force is, however, independent of the piston speed. This is true of both internal combustion and vapor engines. In the former, if the gear ratio be kept constant, a change in piston speed is absolutely without influence on the tractive force. See Equation I.

To show this most clearly, we write Equation I in the new form,

$$F = \frac{p d^2 s g}{2 w} \tag{V}$$

in which  $G = \frac{r}{N}$  = the gear ratio as commonly defined.

Then an ordinary four-cycle motor at 3 to 1 rear axle gear, with 34-inch wheels on the car, should give for each  $4\frac{1}{2}$  by  $4\frac{1}{2}$ -inch cylinder a pulling force of

$$\frac{17 \times 4\frac{1}{2} \times 4\frac{1}{2} \times 4\frac{1}{2} \times 3}{2 \times 34} = 68.3 \text{ pounds.}$$

Generally speaking, if we regard  $p$  as constant at 17 pounds, then for a given car at a given gear,  $g$  and  $w$  being fixed, the tractive force varies with  $d^2 s$ ; for the car considered, it is

$$\frac{17 d^2 s \times 3}{2 \times 34} = \frac{51}{68} d^2 s.$$

Without gears an internal combustion cylinder could exert only one constant tractive force—the steam engine may continuously adjust its tractive force to the load by changing the point of cut-off and thus varying  $p$ . No great variation in mean internal cylinder pressure is possible or desirable in the internal combustion engine. The gears must be depended upon to vary the tractive force when necessary.

Since  $F$  is proportional to  $d^2 s$ , it might appear that there is no special reason for increasing  $s$  in order to attain high tractive forces. But we must go into the matter more searchingly.

### Piston Speed and Rotative Speed

In comparatively recent steam engine practice, a piston speed of 600 feet per minute was considered normal, and anything above this excessive; yet to-day in both steam and stationary gas engine design speeds up to 1,000 and even 1,200 feet per minute are common, and no serious disadvantages have accompanied these increased speeds. They have been attained, at least in steam engine work, by increasing strokes while leaving rotative speeds, revolutions per minute, as they were formerly. When the stroke of a releasing gear engine was limited to 48 inches, a piston speed of 800 feet was about the limit, because the releasing type of valve gear does not work well at rotative speeds exceeding 100 revolutions per minute. With a 5-foot stroke, the same type of valve gear permits of a 1,000-foot piston speed; and this with only minor difficulties, if any, with rod packings and guide and cylinder lubrication. It is the *rotative speed* that limits the performance of any engine, the revolutions per minute.

This is for two reasons: First, because certain types of valve gear, particularly those involving automatic features, do not work satisfactorily above certain speeds. In the internal combustion engine the use of positively actuated valves of the lift type, with suitably stiff springs, has placed this limit at least as high as 1,500 revolutions per minute, a limit far above any ever regarded possible in power plant engines, and probably never to be desirable for such service. Second, because a reciprocating engine wears out by reason of the shocks to which it is subjected. Every revolution includes two serious shocks, each comprising a total reversal of the direction of piston movement. The life of the engine may be expressed, other things being equal, in the total number of reversals it can stand. The more frequently these reversals are made, the shorter the life. High rotative

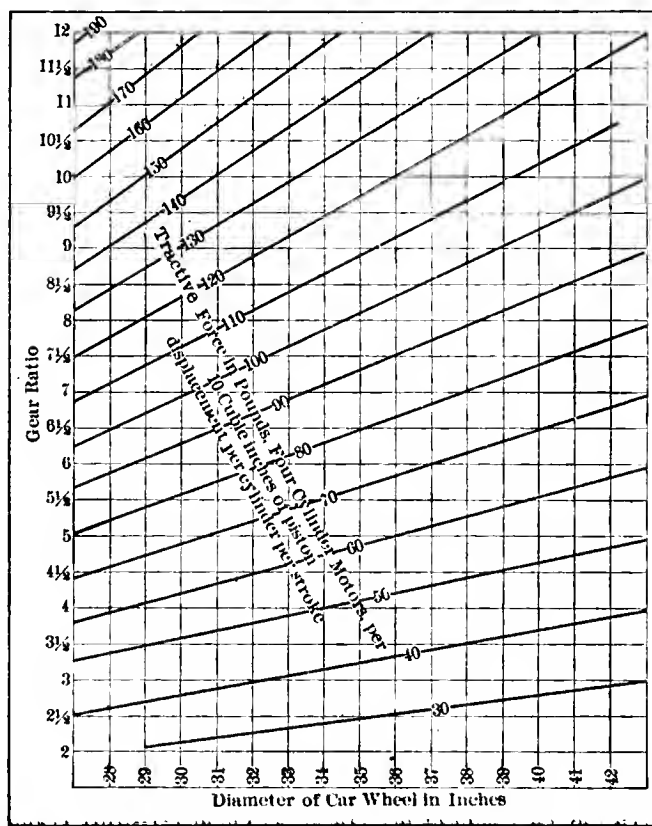

Fig. 1—Chart showing tractive force for various wheel diameters and gear ratios

speeds, therefore, implies durability, increase repair expense and decrease the useful life of the machine. The piston speed is a relatively minor matter. If high piston speed can be attained without high rotative speed, only minor difficulties will be encountered.

### The Long Stroke

To accomplish this end, the long stroke may be employed. For a given piston speed and horsepower the longer the stroke the lower will be the rotative speed and the more durable the engine. For a given number of revolutions per minute and gear, the longer the stroke the greater will be the piston speed, tractive force and horsepower. Design limits the revolutions per minute and running conditions determine the gear. The long stroke then gives maximum pulling force, power and speed. It may add slightly to the initial cost of the motor and may require special design in the arrangement of parts, but these disadvantages, if they are disadvantages, are trifling.

### Efficiency of Long-Stroke Motors

The question is also worth considering from the standpoint of fuel economy. It is sometimes claimed, and the claim seems at first sight reasonable, that a long stroke gives opportunity for more complete expansion, and this improves the cycle of operations. The case is put as in Fig. 2. If 1234 represents the indicator diagram of the ordinary engine, increasing the stroke is thought to give the additional power 4561 at no increased expenditure for fuel. But it should be remembered that the pressure at the end of the suction stroke 71 is principally a matter of valve port friction, and is not much affected by the length of the stroke, so that compression in the long-stroke engine begins at 8 and its indicator diagram is 890h, as compared with 1234 for the ordinary motor. This diagram may still seem to give more work.

Let us carry the analysis a little further: Let the pressure at the beginning of compression be fixed. The law of the compression curve is probably not much influenced by the length of the stroke, so that to obtain the pressure and temperature prescribed by the nature of the fuel at the end of the compression stroke

we must maintain a suitable volume ratio at the two ends of this stroke. In other words, the percentage of clearance should be the same no matter what the stroke of the engine. The compression pressure limits will then be the same for all strokes, but the volume limits will increase with the length of the stroke. The temperature and pressure after combustion will be unchanged, and consequently also the pressure at the end of expansion. Lengthening the stroke will thus be absolutely without influence on the pressure conditions of the cycle. The length of the indicator diagram will, however, be increased.

This true condition of things is suggested by Fig. 3. The indicator diagrams are 1234, 5678, the latter being for the long-stroke engine, and giving the greater amount of power. But this gain in power is not accomplished without cost. At the end of the suction stroke the cylinder is filled with combustible mixture at the pressure  $P_1 = P_2$ , at a definite temperature which is about the same for either type of engine, and a volume  $V_1$  in the one case and  $V_2$  in the other. The weights of mixture present in the two cases are directly proportional, therefore, to the volumes  $V_1$  and  $V_2$ . At the end of the exhaust stroke there remains in the cylinder a volume  $V_3$  or  $V_4$  of mixture, the weight of which will be related similarly to its volume. The weights of mixture drawn into the cylinders will in the two cases then have the ratio  $(V_1 - V_3) \div (V_2 - V_4)$ ,

or will be proportional to the lengths of the indicator diagrams, that is, to the displacements per stroke of the piston. And since pressure factors for the two diagrams are the same, the powers developed will be proportional to these diagram lengths, so that power output will be directly proportional to weight of fuel and air drawn in, and consequently the ideal efficiency will be unaffected by the length of the stroke; yet the longer-stroke engine may have certain practical advantages on the ground of reduced piston leakage.

Clearance in the Motor

In a steam engine clearance causes loss, and the effort is made to minimize it. In the internal combustion engine large clearance is necessary in order to obtain the pressure condition essential at the end of compression. While steam engine clearances vary from 3 to 8 per cent or more in small engines, and great refinement in valve design is practiced in order to reduce it, gasoline engine clearances may range from 20 to 40 per cent., and may as easily be too low as too high. In the steam engine the amount of clearance (linear) is practically fixed by the workmanship and the type of valve gear, and the proportion of clearance (in relation to piston displacement) is consequently reduced by using a long stroke, that is, a high piston displacement per stroke for a given cylinder area. No such argument holds in the automobile motor. It is true that short-stroke motors need less linear clearance than those of long stroke, but there are no designing difficulties in reducing linear clearance far below the permissible standard for internal combustion motors.

Some Practical Considerations

There are now to be considered some factors which, though permitting of less exact analysis, must be regarded in any final estimate. Among the incidental advantages claimed for the long stroke there are:

1. Reduced maximum pressures on parts.
2. Less motor weight per horsepower of capacity.
3. Longer life of motor.
4. Reduced wall area of compression space.
5. Greater economy in fuel.
6. More room for valves and better intake and sparking arrangements.

These we will now investigate.

1—Maximum Pressures

Assuming that the percentage of clearance is the same in both types of motor, then in Fig. 3.

$$P_2 = P_3.$$

If combustion is equally effective in both types,

$$P_2 = P_1 \text{ also.}$$

These latter pressures are the maximum specific pressures in pounds per square inch in the cylinder. The total pressure between piston and cylinder head at or near the end of the stroke is then

$$\frac{\pi}{4} d^2 P,$$

$d$  being the diameter of the cylinder in inches and

$$P = P_2 = P_1.$$

At fixed piston speed and a given gear the horsepower of a motor is proportional to the square of the cylinder diameter. At a fixed rotative speed (the true determining condition) horsepower is proportional to  $d^2 s$ , the square of the diameter multiplied by the stroke. An engine must be designed for a required tractive force and horsepower, so that the value of  $d^2 s$  may be said to be fixed by the conditions. Suppose this value to be 125; so that if  $d=5$ ,  $s=5$ ; if  $d=4$ ,  $s=7.8$ ; if  $d=3$ ,  $s=13.9$ , etc. The motors, 5 x 5, 4 x 7.8 and 3 x 13.9 inches respectively, will at uniform revolutions per minute all give the same power, but the maximum pressures for uniform values of  $P$  will vary as the squares of the diameters, or will be in the ratios  $5^2 = 25$ ,  $4^2 = 16$ ,  $3^2 = 9$ , being about three times as much for the 5-inch cylinder as for the 3-inch.

This enormous difference in pressures is directly related to

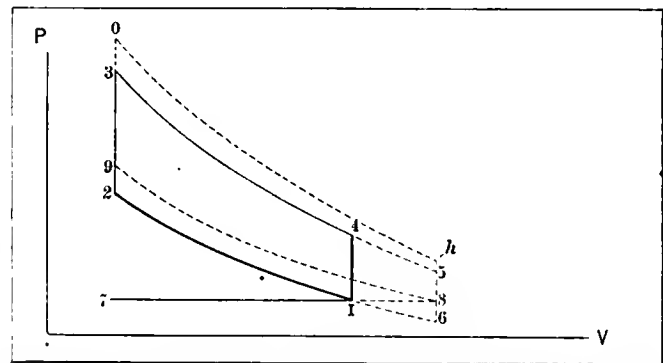

Fig. 2—Theoretical diagram showing the apparent increase in work by use of the long stroke

maximum stresses on cylinder head, piston pin, crank pin and shaft, and controls the design of those parts. Furthermore, the higher pressures cause more lost work in friction, and thus reduce the output of useful work from the engine.

2—Motor Weight

The wall area of the cylinder is made up of that of the head,  $\frac{\pi}{4} d^2$ , and that of the barrel, which we may call  $\pi d s$ . If differences in wall thickness be ignored the total wall area, volume of metal and weight of the cylinder will be proportional to  $\frac{\pi}{4} d^2 + \pi d s$ . This quantity increases less rapidly than the horsepower (a function of  $d^2 s$  at constant revolutions per minute) as the diameter is increased, so that at first sight it would seem as if large diameters and short strokes were favorable to light weight per horsepower.

But the stress on the metal in the barrel of the cylinder is proportional to its diameter, and the wall thickness must be increased in the same ratio as the diameter, even though the specific pressure inside remains constant. We may, therefore, regard this part of the wall as varying in weight directly as  $\pi d s \times d = \pi d^2 s$ . The cylinder head may be regarded as a sort of compound beam supported at its rim and uniformly loaded. The breaking stress varies as the length of the beam, that is, as the

diameter of the head, so that the weight of metal in the head is proportional to

$$\frac{\pi}{4} d^2 \times d = \frac{\pi}{4} d^3,$$

and the whole weight of metal in barrel and head varies as

$$\frac{\pi}{4} d^3 + \pi s d^2,$$

a quantity which for usual values increases more rapidly with  $d$  than does the horsepower. The long stroke may, therefore, reduce weight of motor per horsepower of capacity.

For example, compare a 4 by 4 motor with one 4 by 6. The horsepower capacities bear the ratio

$$\frac{4 \times 4 \times 4}{4 \times 4 \times 6} = \frac{2}{3} = 0.667.$$

The head areas are each  $0.7854 \times 4 \times 4 = 12.6$  square inches. The wall areas are, short stroke,  $3.1416 \times 4 \times 4 = 50.4$  square inches; long stroke,  $3.1416 \times 4 \times 6 = 75.53$  square inches. The total areas are  $50.6 + 12.6 = 63.2$  and  $75.53 + 12.6 = 88.13$  square inches, respectively. The ratio of these figures is

$$\frac{63.2}{88.13} = 0.716.$$

Suppose the first motor to weigh 200 pounds and its output to

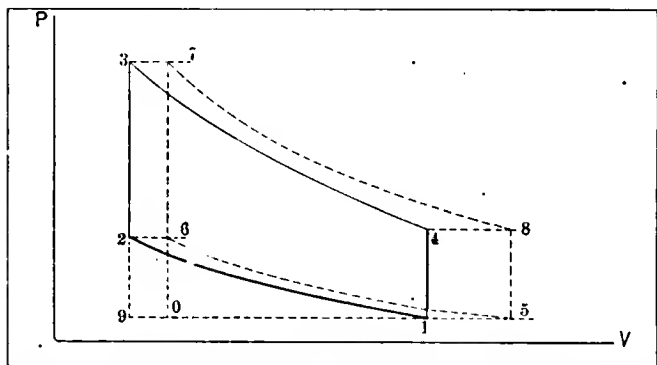

Fig. 3—The true gain in work is not so great as the apparent gain, as here shown

be 35 horsepower; then the second will weigh  $0.716 \times 200 = 143.2$  pounds, and its horsepower will be  $35 \times \frac{2}{3} = 23.3$ . Its weight per horsepower is  $143.2 \div 23.3 = 6.11$  pounds, while that of the long-stroke motor is  $200 \div 35 = 5.71$  pounds. If the 35 horsepower had been obtained by increasing the number of cylinders of the short-stroke motor the required weight would have been  $35 \times 6.11 = 214$  pounds, or 14 pounds greater than that of the long-stroke motor.

### 3, 5—Longer Life and Greater Economy

The former of these factors has been discussed under *piston speed and rotative speed*, the latter under *stroke and ideal diagram and clearance*. Some additional considerations as to the latter may be suggested by the paragraphs on *maximum pressures*. A considerably longer life may be expected from the long-stroke motor; any direct increase in thermal efficiency due to its use seems likely to be small.

### 4—Reduced Wall Area of Compression Space

If  $a$  be the proportion of clearance, the length of the clearance or compression space is  $as$  and its side wall surface is  $\pi d a s$ .

Adding the head surface,  $\frac{\pi}{4} d^2$ , we have  $\pi d a s + \frac{\pi}{4} d^2$  as the

total surface exposed to radiation at the end of the stroke. This varies more rapidly than the horsepower, as the diameter is increased, so that long-stroke motors have proportionately less wall area in the compression space than those of short stroke.

Consider a 4 by 4-inch and a 3¼ by 6-inch motor, both giving the same horsepower. If 30 per cent. of clearance is needed the linear clearance of the first motor may be taken as 1.2 inch, and its clearance wall surface is  $(3.1416 \times 1.2 \times 4) + (0.7854 \times 4 \times 4) = 15 + 12.6 = 27.6$  square inches. That of the 6-inch-stroke motor (with 1.8 inch of linear clearance) is  $(3.1416 \times 3¼ \times 1.8) + (0.7854 \times 3¼ \times 3¼) = 18.3 + 8.3 = 26.6$  square inches, the slight advantage being in favor of the second motor.

It is difficult to see any vital importance in this peculiarity (at least in connection with automobile motors). Possibly the maximum pressure,  $P_s = P_r$ , Fig. 2, might be increased slightly by a reduction of wall area, with consequent good results as to thermal efficiency, and, of course, some loss of any proposed advantages in respect to maximum pressures and motor weights; but the cylinder walls must be cooled anyway, and at high piston speeds with comparatively small cylinders it is doubtful whether any difference in maximum pressures or shape of expansion curves could be traced to a difference in wall area of compression space.

### 6—Room for Accessories

The necessarily longer clearance space does, nevertheless, affect in an important way the arrangements for admitting, igniting and exhausting the combustible mixture. The area of the head

being  $\frac{\pi}{4} d^2$  and that of the side walls of the compression space  $\pi d a s$ , while the prescribed volume of clearance space is  $\frac{\pi}{4} d^2 a s$ ,

we find that the space on the head varies as the clearance volume (and consequently at fixed revolutions per minute and clearance ratio, as the horsepower), while the available space on the side walls varies less rapidly. With long strokes and small diameters side wall space is more available for accessory attachments.

### Summary of Facts

The long-stroke motor seems to have fully justified its existence. Some of the arguments advanced in its favor may fall to the ground under close examination; it is a mechanical rather than a thermal device, and its advantages are mechanical rather than those related to thermal efficiency. In steam-engine practice equality of bore and stroke is a feature only of high (rotative) speed engines. With piston speeds pretty well standardized, the higher the rotative speed the shorter the stroke, and the lower piston speeds, shorter strokes and higher rotative speeds have all been necessarily associated with the smaller engines. This condition of things probably influenced early standards in the design of internal combustion motors. There is no sufficient reason why it should continue to do so. It was a wrong condition, and steam-engine builders are now resorting to higher piston speeds, particularly in large units. Large gas engines have led the way by demonstrating the feasibility of piston speeds exceeding 1000 feet per minute. With the high-duty requirements of the automobile motor it is reasonable to go still further, and if 1000 revolutions per minute has been found satisfactory for a 4-inch stroke, giving 1000 feet piston speed, the same rotative speed with a 6 or 7-inch stroke, giving 1500 to 1750 feet piston speed and an increase of 50 to 75 per cent. in power with the same diameter of cylinder, is justifiable.

**CLEANING RUSTY PARTS**—It has been discovered by accident that a rusty part which could not easily be cleaned by pickling in an acid bath can be disposed of quickly by first immersing it in a strong alkaline bath, which also serves to remove whatever grease may adhere to it. A strong solution of soda or caustic potash is heated and the part is left one-half hour therein. Then a solution of one part of hydrochloric (muriatic) acid to four parts of water will remove the rust. Thereafter the part is rinsed in a weak solution of carbonate of soda and brushed with water and pumice. The rinsing is necessary only if the part must be used at once. Otherwise it is simply wiped dry.—From *Cycle et Automobile Industriels*.



# Digest of the Leading Foreign Papers

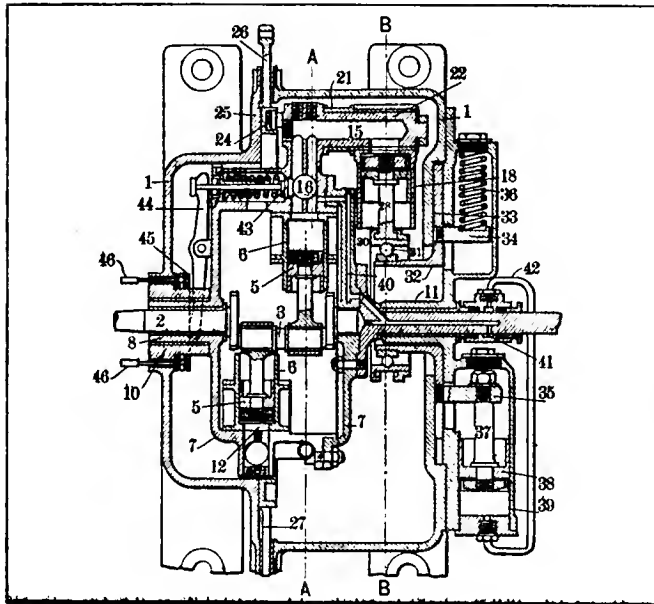

Fig. 1.—The Louis Renault hydraulic transmission

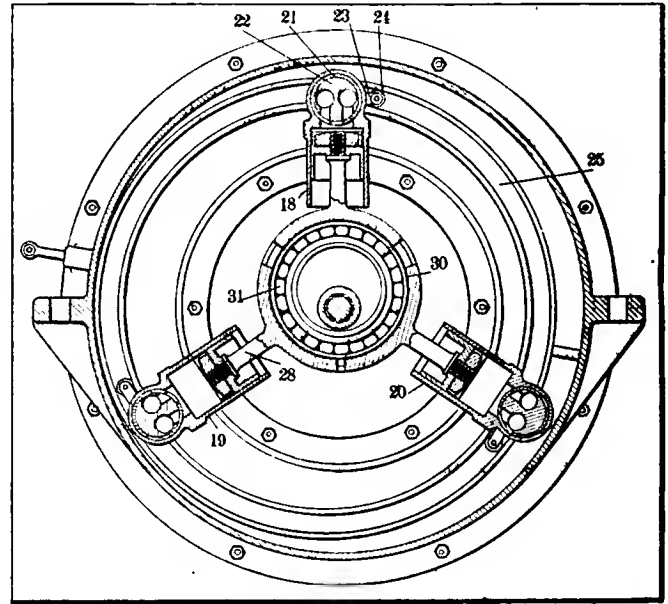

Fig. 2.—Mounting of driven pumps—Section B B in Fig. 1

THE author describes and illustrates a series of mechanisms in which the functions of an infinitely graduated clutch, permitting the starting of a vehicle—a heavily loaded truck for example—at a highly reduced speed, are supposed to be combined with those of a change-gear mechanism, by which the power applied to the driving wheels is increased in proportion as their speed is reduced. In a preliminary discussion of the subject it was argued that in most hydraulic transmissions the designers are deluding themselves with regard to the power obtained at low vehicle speed. The reduced speed of the drivenshaft is generally obtained by a graduated slip in the action of the oil against the driven parts, which slip, however valuable for clutch and starting action, creates friction in the oil conduits and is consequently transformed into heat, but is not delivered to the drivenshaft in the form of power. In one part of the series, the Williams-Janney hydraulic transmission, in which this defect is to a great extent avoided, was described in THE AUTOMOBILE of November 2, and this construction, which has been adopted by the Delaunay-Belleville company of France, is a modern adaptation from the American Cooper-Hampton patent of 1894. Among other constructions described those designed by Louis Renault of France and Professor Hele-Shaw of England, are notable by reason of the prominence of the designers and the fact that in both a direct drive at the adjustment corresponding to high gear in a mechanical transmission is obtained by locking the driving and the driven parts together by immobilizing the oil between them. In neither case, however, does the author seem to consider that the power efficiency at low vehicle speed has been established.

By carefully following the reference numerals on Fig. 1, while realizing that each of the three driving pumps in this relatively complicated mechanism has a corresponding driven pump and that the oil piping connecting them is partly transverse of the mechanism and partly circumferential, the reader may arrive at an understanding of the Renault hydraulic change-gear and transmission, the patent for which dates back to 1906.

## Hydraulic Transmissions—II Renault and Hele-Shaw Types

In a general way the mode of operation is as follows: When the pistons 5 of the three driving pumps are prevented from moving because the passages are closed which connect the oil in them with the circulation, the rotation of the motor shaft 2 effects, instead, the rotation of the inner casing 7, to which the driven shaft 9 is secured, and the latter is therefore rotated as in direct drive. If the passages are open which permit oil discharged from the driving pumps to go freely into the circulation without passing through the driven pumps, the transmission is in neutral. If these passages, valves 43 in the drawing, to the circulation (the mass of enclosed oil) are closed, the driven oil exerts a pressure upon the pistons of the driven pumps, but these are mounted upon a ball-bearing which is normally concentric with the axis of rotation of the mechanism and cannot reciprocate; in other words, the driven pumps cannot discharge oil and the drive is therefore still direct. It is, however, only a strong spring, 36, which holds the inner ends of the driven pistons in their inoperative position of concentricity. Suppose the throttle of the motor is opened wide while the load is much increased, the pressure on the driven pistons is then much increased and may be sufficient to overcome the spring resistance referred to. To this end passages communicate the pressure to a separate adjustment piston, 37, working in a separate cylinder, by the movement of which against the spring's resistance the sleeve is displaced more or less from the concentric position. The greater the surplus pressure over and above that of the spring, the greater the displacement and the resulting eccentricity. Now, the driven pistons are enabled to reciprocate, the valve mechanism being of course such as to co-ordinate their movements with those of the driving pistons and with reference to the masses of oil displaced in each system of pumps, the driving and the driven. If the driven pistons are adjusted so as to discharge only a small portion of the oil which the driving pumps could deliver if they were, free to move, the action of the driving pumps will be correspondingly reduced (as on direct drive it is reduced to nothing) and the balance of the

available energy in the motorshaft will be expended in turning the inner casing 7, and the drivenshaft secured thereto; the speed of the drivenshaft being reduced as compared with that of the motorshaft in proportion as more or less oil is permitted to escape through the driven pumps.

When high pressure in the whole system of passages causes the ball-bearing sleeve which determines the possible movements of the driven pistons to take a strongly eccentric position, the rotation of the casing 7 and of the drivenshaft is of course reduced to a minimum, and it seems to be the designer's idea that for this reason the mechanism accomplishes the same that is accomplished on the low gear of a mechanical transmission. The author, on the other hand, considers that the designer has produced only a clutch, with graduated slippage.

The detail of operation of this hydraulic set follows: The motor shaft 2 controls the three pistons 5 which move in pump cylinders 6 pivotally secured to a drum 7, to which is secured in turn the driven shaft 9. The pumps communicate with the fluid in the drum and casing through the passages 12, which alternately register with the admission channel 13 and the discharge pipes 14, and they communicate mutually as well as with three larger driven pumps 18, 19 and 20, Fig. 2, by the passages 15 shown in Fig. 1 and 16 and 17, shown in Fig. 3. The fluid feed of the driven pumps is regulated through the cylindrical distributors 21 around which the pumps oscillate and which themselves oscillate on the shafts 22 with a movement controlled from the crankarms 23, which moves on rollers 24 in the circular path 25, and whose eccentricity with relation to shafts 2 and 9 is regulated by the rods 26 and 27.

The piston rods 28 of the driven pumps are fixed upon the outer race 30, of ball bearing 31, mounted upon the sleeve 32, which forms the integral cylindrical hub flange of plate 33, which may be placed in a more or less eccentric relation to the axis of the mechanism, being controlled in this respect at 34 and 35 through the spring 36 and the piston 38, the latter moving in a cylinder 39, which communicates with the two systems of pumps

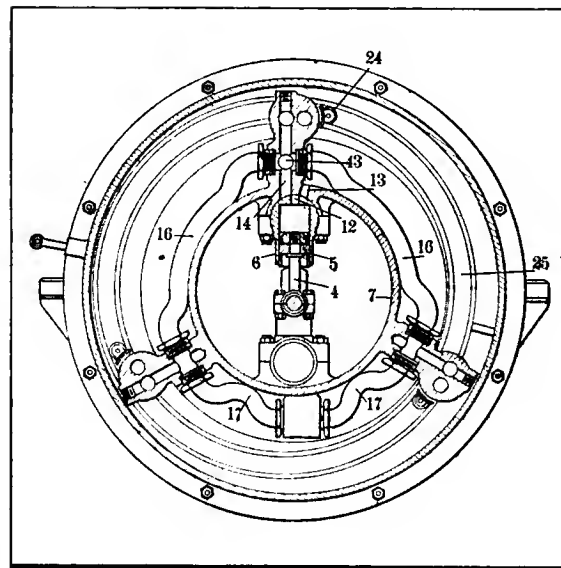

Fig. 3.—Transverse section of Louis Renault hydraulic transmission, on line AA in Fig. 1

by channels 42, 41, 40 and 16.

Normally spring 36 maintains 32 concentric with driven shaft 9 and, in this adjustment, if the valve 43 is opened by means of the control device 46, 45 and 44, so as to place the pipes 16 in direct connection with casing 1—full of oil—and with drum 7, the three pumps 6, turned by shaft 2, will draw oil therefrom and will discharge it into 15, 16 and 17 without the fluid exerting any notable pressure on the pistons of the driven pumps. If 43 is closed, this pressure is increased but without displacing the pistons of these pumps, because the cylindrical flange 32 is concentric with shafts 2-9; and the drum 7 and shaft 9 are drawn along together at the speed of the motor shaft 2.

If the pressure in the oil circulation is increased beyond the limit determined by spring 36, piston 38 is moved and displaces plate 33, with its flanged hub 32, eccentrically, so that the pumps 18, 19 and 20 begin to discharge oil proportionately to the eccentricity. The speed of shaft 9 is hereby automatically reduced in proportion to any increase in the resistance against its rotation.

To reverse the vehicle movement, it is sufficient to apply the control levers 36 and 37, which act on the locking device 25 by which the eccentric adjustment of the driving pumps may be changed about, causing the periods of oil intake and oil discharge in the driven pumps to be reversed with relation to those of the driving pumps 6. Shaft 9 will then turn in the opposite direction to that of the motorshaft and with less speed.

In the Hele-Shaw hydraulic transmission, Fig. 4, the system of driving cylinders A and the system of driven cylinders B are both secured upon the shaft F. The pistons of cylinders A impinge upon a circular track in two parts, C1 and C2, the latter integral with or secured to the control system E and E2, which may be operated by means of the handwheel D1 so as to separate the two parts of the track, thereby varying its shape from circular to oval. The rollers R1 of the driven cylinders B travel on an elliptic path B1, Fig. 5, which is not subject to variation. The intake and discharge of oil from cylin-

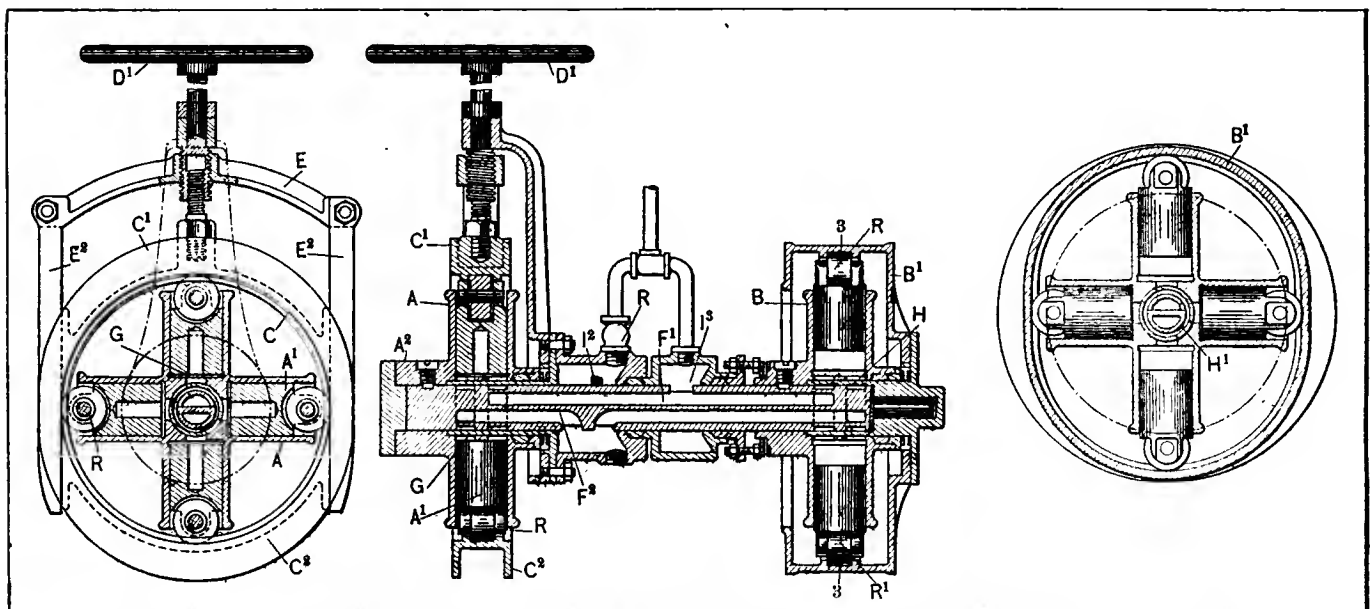

Figs. 4 and 5—Cross and transverse section of the Hele-Shaw hydraulic transmission

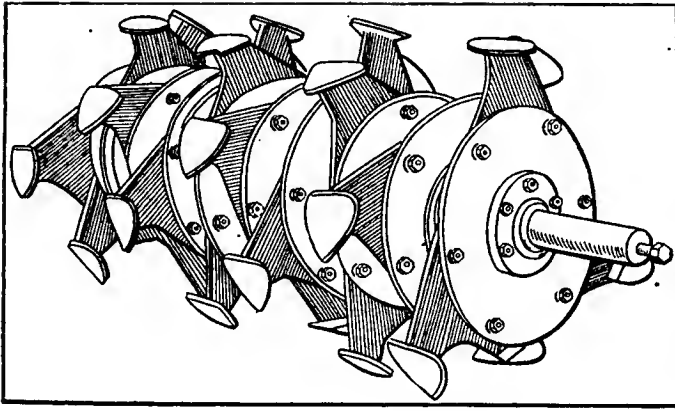

Combined rotary plough and harrow tool, made in Germany

ders A and B are regulated by the circular valve disks G, Fig. 4, and H1, Fig. 5, which are secured respectively to shaft F and to B1. If the track C1-C2 is maintained strictly circular, the motor shaft A2 rotates the whole system, A, F, B, and B1, as a unit, the immobility of the pistons A1 in their cylinders preventing the pistons of the B system from budging in theirs, and causing the B system to take along the oval track B1 and the driven shaft which is secured to it, as if these parts were integral with the motor shaft and the system of driving cylinders. The pistons of the B cylinders will, on the other hand, be free to move in proportion as the parts C1 and C2 are separated (ovalizing the track for the rollers of A), and if their movement is sufficient to cause the cylinders B to accommodate their positions to the ellipticity of the track B1, at the speed of the motor shaft's rotation, B1 will remain stationary. This is the result when the C track is adjusted to be as oblong as the B1 track always is. At a further lengthening of the C oval, the

reverse should be effected. On the other hand, the nearer the C track remains to the circular shape, the smaller is the angular velocity of B1, but it seems questionable if the force which compels B1 to rotate under these circumstances is efficiently applied or is mainly to be looked upon as wasted in slip between the rollers of cylinders B and the track B1.

The return channel for the fluid, through the interior of shaft F, is in communication, at I3, with an oil reservoir from whose oil reserve losses from leakage are made good; and the pressure-channel F2 communicates, at I2, with a valve R which limits the pressure in the mechanism.—From serial article by Ch. Faroux, in *La Vie Automobile*.

**MOTOR POWER CREATES NEW FARM IMPLEMENTS**—In the manufacture of agricultural motor implements the thought is coming to the surface that it should be possible to do with a single tool the work which is now either done imperfectly with the plough alone or with considerable waste of labor successively with a plough and a harrow or with spade and hoe. The perfect condition in which, for example, the mole leaves the ground which it throws behind it, suggests a tool somewhat of the shape of its obliquely working shovel-like forefeet provided with pointed claws on the cutting edge. An innovation in this direction is the Linard-Hubert motor plough with "striking shares" which took part in recent agricultural contests in France. Another is shown in the accompanying illustration of the tool used with the farm-work tractor made by Heinrich Lanz of Mannheim, Germany, under patents to Koeszegi. This tool is a rotary hoe. The triangular hoe blades are not tangential to the circle in which they rotate but at a sharp angle with a tangent and have been found efficient in various trials by agricultural societies in Germany for producing the desired loosening of the deeper portions of the soil as well as the proper mixing of manure with the top soil, while the edges of the discs of which they form a part take care of the first breaking of the surface.—*Deutsche Technik*, November 1.

## Harking Back a Decade

FROM *The Motor Review*, December 5, 1901:

Banker Brothers have incorporated under Pennsylvania laws under the title Banker Brothers Company, capital \$50,000. The company is considered the largest dealing in motor vehicles at retail in the United States. It has taken on the Peerless line in addition to its other stock.

The horse-drawn stages on Fifth avenue, New York, are all destined for the discard. The new electric stages with red wheels and yellow bodies make a fine show.

With the first of the year the Winton Motor Carriage Company announces that its capacity will be between twenty and twenty-five complete automobiles a week. J. Bechtel, formerly superintendent of the Black Manufacturing Company, at Erie, making bicycles, has been added to the Winton staff as a mechanical expert.

William E. Metzger has been appointed Detroit agent for the Winton. Carl G. Fisher, of Indianapolis, will distribute the Winton line in that territory. Harry Fosdick, of the Locomobile Company, has resigned to accept the Winton agency in Boston.

The Stearns Steam Carriage Company announces that in future when it sells a car, it will send an expert instructor with the car to its purchaser to teach the buyer how to run it. The buyer is expected to pay the expert's expenses, but the company will pay his salary.

The first motor delivery wagon to make its appearance in Lawrence, Mass., is a steam car made by the Mobile Company of America. It has a covered body, capacity of 1,600 pounds and a speed of 20 miles an hour.

The Knox company secured enough business from the recent

show to keep its factory busy on three and four-wheelers for a period of three months. The four-wheel model for 1902 is an attractive car and proved itself a hill-climber recently by going up the Cross street hill at Springfield, Mass., making the ascent half way on high gear. The car performed well despite the fact that it was a crisp morning.

The E. R. Thomas Motor Company explains the fact that its new cars were not exhibited at the recent show on the ground that it does not believe in fall shows. The chief objection raised was that other manufacturers attend fall shows simply to get ideas for their own product. Hence it reserved its exhibit until a time when it will be too late for competitors to copy.

The first race meeting ever held in Washington took place Thanksgiving Day. Three events were run, one of which was for gasoline cars. This was captured by Lewis Hill, name of car not given.

The National Capital Automobile Club and the Washington Touring Club have decided to amalgamate. The new club-rooms will be in the Pope building.

Ten members of the Rhode Island Automobile Club have contracted to buy 20-horsepower Winton cars especially adapted to racing. Plans are on foot to build or secure a race track near Newport.

Exports of automobiles and parts from New York for last week were just under \$7,000 in value.

The Krastin Automobile Manufacturing Company, recently incorporated at Cleveland, expects to employ 200 men in its new plant. The company has experimented with a new type of gasoline automobile and expects to begin operations immediately.

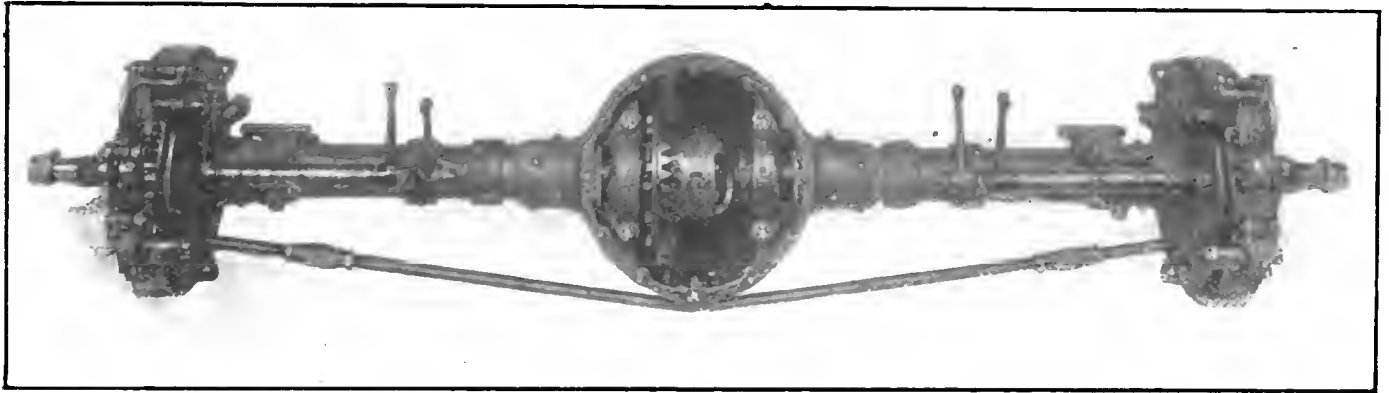

Fig. 1—View of the G. J. G. rear axle, showing rigid construction

## Unit Power Plant Features the G. J. G.

FOR the season of 1912 the G. J. G. Motor Car Company, of White Plains, N. Y., has brought out a chassis, equipped with a unit power plant. The motor has four cylinders cast in pairs, with a bore of 3 3/4 inches and stroke of 4 1/2 inches. The horsepower of the motor is rated by the makers at 26. The valves are all on the same side of the cylinder. Water jackets are cast integrally and are made so as to provide easy water circulation. The material from which the cylinders are made is reverberatory air-furnace iron. To provide an easy turning moment for any position of the piston the cylinders are offset a distance of 3/8 inch.

The pistons are made of extra length so as to provide a good bearing surface, and eliminate chances of compression leaks. They are provided with three eccentric rings fitted with lap joints. The material in the pistons is also of reverberatory air-furnace iron, and in order to provide for a good fit, both the pistons and rings are ground to size. The wristpin is fitted into a bushing of good size and so arranged as to give a small amount of clearance for the upper connecting-rod bearing. The wristpin bushing is open at either end so that oil may pass into it, and through an opening into the bearing. There is a slight counter-bore in the cylinder just above the top of the stroke.

The connecting rods are fitted to the wristpin by a clamp joint through which a bolt passes by means of which the tightness of the wristpin bearing may be regulated. At the lower end of the connecting rod the bearing is of good width. The

material in the connecting rods is open-hearth steel, and they are drop forged and hardened. At the lower end they are fitted with bushings of die-cast cadmium nickel bronze. The connecting rods are of I-beam section, according to the usual practice.

The crankshaft is made from a drop forging of carbon steel which is heat-treated and ground. It runs upon three main bearings and is flanged at the rear end in order to provide a fastening for the flywheel, which is bolted thereto. The three bearings are located as follows: two at the ends of the crankcase and supported by webs in this casting, while the third rests upon a bridge formed by a vertical partition which extends across the crankcase.

The camshaft is a one-piece forging hardened and ground to size, and having large diameter. The cams, which are integral parts of the camshaft, are provided with a wide face to eliminate rapid wear. The camshaft is driven by means of three spur gears located in a casing at the forward end of the motor. This casing is shown at G, Fig. 3. These three gear wheels constitute the entire driving mechanism for the camshaft, water pump, magneto, etc., and hence noise due to clashing gears is eliminated as far as possible. The valves are made with nickel steel heads and carbon steel stems, and are set side by side on the left side of the motor. The lifter rods are actuated directly by the cams, and the mechanism is made certain by the employment of large springs which are fitted on seats just above the adjusting screws. The springs and adjusting nuts are readily ac-

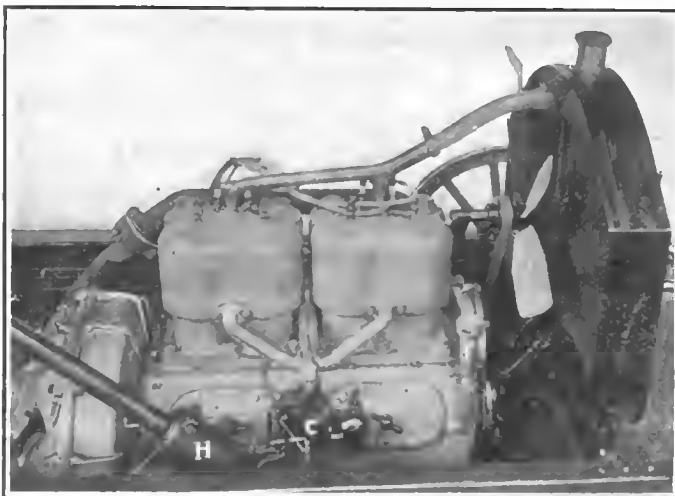

Fig. 2—Water and gas manifolds are cast integrally

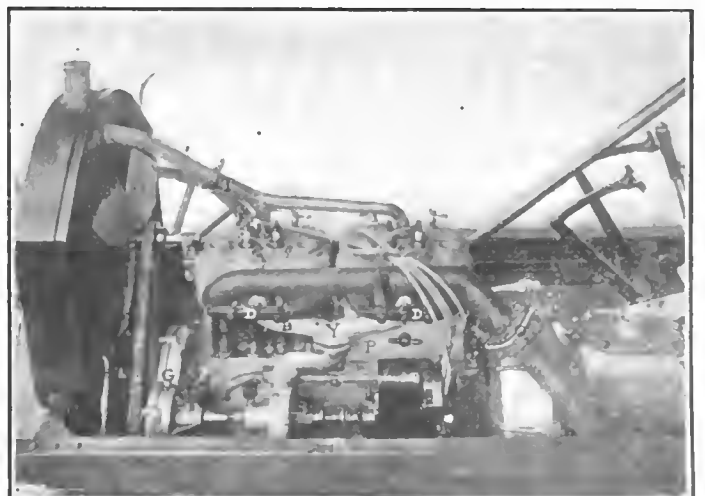

Fig. 3—The compact valve side of the G. J. G. motor

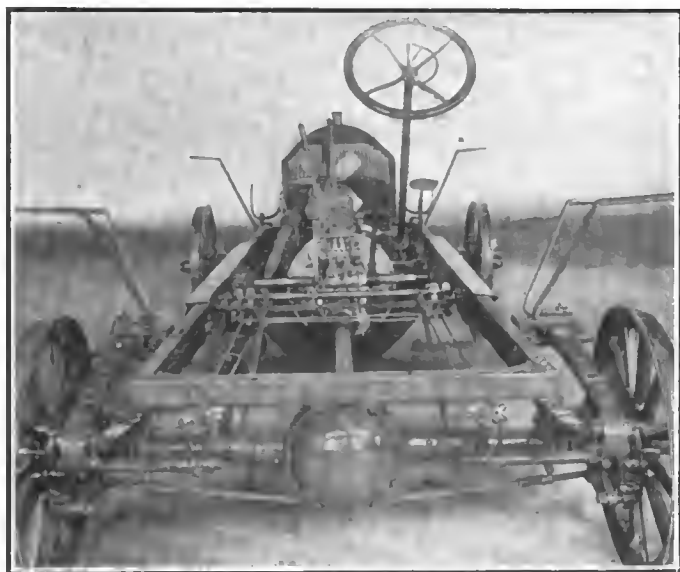

Fig. 4—End view of chassis, showing rear axle suspension

cessible by the removal of the side cover-plate P. This cover plate is held by a bolt which can be turned by hand as may be seen from the illustration. The adjustment nuts are for the purpose of regulating the valve action when it becomes necessary after having ground the valves to a considerable extent. These adjustment nuts will also compensate for wear in other parts of the valve mechanism.

The water by means of which the motor is cooled is circulated by a centrifugal pump which is driven by a gear through a transverse shaft. The water intake manifold surrounds the gas intake manifold and passes from the left side of the motor between the two central cylinders transversely across the crankcase to the right side of the motor. After having passed clear of the cylinder castings the water intake pipes are led to the lower part of the jackets on the right side of the motor, and are fastened there by elliptical flanges through which pass two bolts. After having circulated through the jackets, which are so shaped as to be wider near the top, or more heated part of the combustion chamber, the water is led back to the upper part of the radiator. The connection between the water outlet manifold and the radiator intake is of rubber hose 1-4 inches in diameter. It is fastened to the manifold by means of a clip T. A similar clip secures it to the intake pipe of the radiator. The radiator is of the Mercedes type and is cooled by means of a four-bladed aluminum fan, driven by an adjustable belt from the forward end of the magneto shaft. The fan bracket is supported by

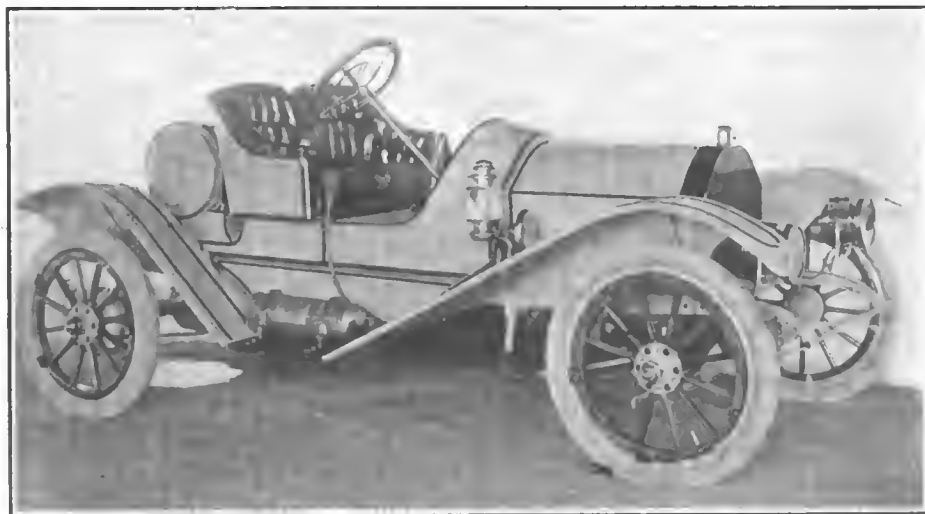

Fig. 5—Runabout body which is fitted to the G. J. G. chassis

a small flange on the forward end of the first cylinder at F.

The lubricating system is a combination of the force-feed and gravity methods. The oil is contained in a reservoir which is formed by the lower part of the crankcase casting. A gear pump at the forward end of the casting lifts the oil from the reservoir and transmits it to a lead above the crankshaft. This oil flows into pockets along the walls of the base chamber so arranged as to lead directly through ducts to the main bearings. The oil flows through these ducts by gravity and amply lubricates the bearings, which are lined with die-cast cadmium nickel bronze scraped to fit.

Other leads are fitted over the crank bearings and so arranged that the oil will also flow into them by gravity, thus giving them an ample supply. Besides lubricating the crank bearings the oil will be thrown by centrifugal force, due to the rapidly revolving crankshaft, up into the cylinders, the walls of which will be covered by a supply of oil after the engine has been running for a short time. The piston on its downward stroke becomes covered with the oil, then on the next succeeding upward stroke carries it to the upper part of the cylinder, thus lubricating this important member. Besides lubricating the cylinder the oil thrown off the revolving crank also lubricates the camshaft and all other revolving parts of the motor.

#### Details of the Lubrication Scheme

After having lubricated the motor the oil will drip back to the lower part of the casing and eventually drain to the bottom of the crankcase. A screen is inserted through which all the oil must pass before it can again enter the oil pump. At the suction opening of the oil pump there is a slight depression in the bottom of the crankcase reservoir which forms a sort of oil-well. This depression will insure a quantity of oil for the pump in case the engine should be going up a hill without having an ample supply of oil in the base. The pump is on the same shaft as the timer and is so arranged that no stuffing gland is used; therefore, there will not be any chance of leakage at that point. On the right side of the crankcase at the forward end there is a projection into which the oil filler pipe F, Fig. 2, is inserted. It is provided with a screen of wire gauze through which the oil which is put into the crankcase must pass. This precaution obviates the chances of waste or other foreign material entering the crankcase while the oil supply is being replenished. The crankcase which contains the oil system is of aluminum alloy of barrel design. This construction gives great rigidity and durability.

Ignition is effected by means of the Bosch dual system, consisting of Bosch high-tension magneto, which delivers current to one set of spark plugs while an independent set of spark plugs may be used in combination with a battery and coil set for starting purposes.

The carbureter C is located on the right side of the motor supported by the intake manifold, which passes as described from the carbureter to the other side of the motor, and thence to the intake port. Since the water manifold is cast integrally with the gas manifold a uniform quality of gas is assured at all times on account of complete gasification of all the gasoline due to the heat. The intake manifold is provided with a flange to which the Y-shaped piping is fitted as shown at Y, Fig. 3. From this point the gas passes directly to the intake ports.

The exhaust manifold is provided with an outlet of 2-inch steel tubing. It is held in position by means of broad flanges and stud bolts B which pass through the dogs D. On the rear dog a clip is fastened as shown at R which



holds the wires from the magneto and secures them against the vibration of the car. The exhaust manifold is led back to a position parallel to the rear end of the rear cylinders. It then dips down and ends in a flange at Q where the exhaust pipe which leads to the muffler is joined to it and held tight against leakage by means of a gasket fitted between the flanges.

The clutch is of the multiple-disc type and is contained in the flywheel. A view of the clutch housing may be had in Fig. 7 at C. This housing, which is continued back from the crankcase, is of aluminum alloy and ribbed so as to give strength and rigidity. A vertical flange passes around the circumference of the housing and forms the means of connection between it and the gearset housing. A hand-hole is fitted at H so that inspection is easily possible.

The clutch is so designed that a constant stream of oil is poured upon it while the engine is in motion. The discs of which the clutch is composed are of saw steel tempered and ground. The clutch is operated by means of a pedal shown at P, so constructed that a very light pressure upon it will release the clutch.

Power is transmitted through a short shaft to the gearset. This is of the three-speed selective type, having  $2\frac{3}{4}$ -inch shifter rods extending from the rear of the case. Each of these shifter rods is  $1\frac{1}{8}$  inches from the center line of the motor and  $4\frac{14}{32}$  inches above the shaft. The change speed lever is shown at L and works in the H-quadrant Q. The gearset shafts are carried on imported ball bearings, while the gears are all designed so as to have a large diameter and a wide face. The material of the gears is high carbon steel, heat-treated and hardened. The gear-shifting shafts are equipped with a positive interlocking system so arranged as to positively eliminate the possibility of two pairs of gears being in mesh at the same time. All studs, nuts and shafts are made from selected high-grade steel.

A universal joint fitted in the casing D takes up the transmission of power from the gearset and delivers it to the propeller-shaft. The propeller-shaft is surrounded by a torque-tube in order to eliminate strains due to irregularity of the road.

From the propeller shaft the drive is transmitted to the differential and semi-floating rear axle and thence to the rear wheels. The rear axle is encased in a pressed steel housing which is fitted at the differential with a circular inspection plate. In order to provide stiffness a tie rod is fitted which passes from the extremities of the axle beneath the differential casing and is joined by turnbuckles upon which adjustments may be made for tightness. The front axle is an I-beam drop forging having the spring seats forged integrally.

#### The Braking System Is Adequate

The brakes are on the rear wheels and work through equalizers on 10 3-4-inch brake drums. The service brakes are operated by means of a pedal, while the emergency brakes are controlled by the lever B, Fig. 7, on the left side of the driver's seat. The wheels are of the wood artillery type, having twelve spokes both front and rear. They are adapted for 32 x 3 1-2 inch tires all around. The tread is 56 inches, and the wheelbase 104 inches.

The chassis frame is of channel construction without drop. It is supported in front by semi-elliptic springs, while in the rear the springs employed are elliptic with scroll ends.

The steering gear is of the irreversible worm-and-sector type. It is inclosed in a housing at the lower end which may be seen at H, Fig. 2. The hand wheel is of 18-inch diameter constructed on an aluminum spider which holds the spark and throttle levers and quadrants. There is an adjusting screw fitted so



Fig. 6—The G. J. G. fore-door touring car for 1912

that all wear on the worm may be taken up, thus increasing the life of this part of the steering gear. The control of the car is by means of the spark and throttle levers on the steering wheel, the brake and clutch pedals, and the two levers which are located on the left side of the driver's seat. An accelerator is also included in the equipment of the car, as well as a muffler cutout.

Other equipment consists of a full set of Dorian quick detachable, demountable rims, with an extra rim, gas head lamps and Prest-O-Lite gas-tank, oil side and tail lamps, horn, tire repair kit, oil can, pump, jack and full roll of special tools. The color is coachbuilder's deep blue, with black stripe, gold hairlines, and black leather upholstery. The bodies furnished on this chassis are the runabout or touring type as desired.

**PISTONS OF ALUMINUM ALLOY**—Several German, French and English houses now produce aluminum alloys whose strength and fusion point are sufficiently high to admit of the material being used for pistons and connecting rods. Such parts would have not only the advantage of lightness but, at equal strength with parts of steel, would be superior in rigidity and in ability to carry away heat from the combustion chamber. For this purpose the piston made of aluminum alloy might be provided with interior radiation fins, as has been done in a few instances before suitable alloys had been made commercially available.—From *La Vie Automobile*, Nov. 4.



Fig. 7—View of flywheel and clutch housing. Note control levers in center

# Letters Answered and Discussed

## Camshaft and Magneto Gears

EDITOR THE AUTOMOBILE:  
 [2,937]—How are the magneto and camshaft geared to the crankshaft of the motor? And in a four-cycle motor at what speed should the magneto-shaft and camshaft be driven?

C. B. AMES.

Pueblo, Col.

The camshaft is driven from the crankshaft by two-to-one gearing; that is, the camshaft gear is twice the size of the crankshaft gear, and hence the camshaft rotates at half the speed of the crankshaft. Usually the magneto is driven at the same speed as the latter. Fig. 1 shows the relative sizes of these gears and the way they are connected when a single camshaft is used; that is, when the valves are all on one side of the motor.

## Nut-locking Device

EDITOR THE AUTOMOBILE:

[2,938]—Do you know of any way of preventing the jarring loose of small nuts (such as those on the magneto and carbureter), due to the vibrations of the motor

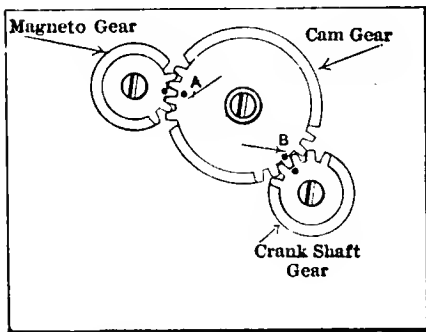

Fig. 1—Gearing for driving magneto and camshaft

and jar of the road? I have lost a number of them in this way and have wondered if there was not some means of holding them except by the use of an extra nut as a locknut.

C. N. TAYLOR.

Murfreesboro, Tenn.

Perhaps the form of locking device which you desire is shown by Fig. 2. This does not require the use of an extra nut, and is very simple. The spring piece is fastened with a pin at the smaller end and the other end is made so that it will just fit over the nut. When the nut is to be turned the piece is pressed down until the nut is clear. You should be able to purchase these holders where automobile supplies are kept, although it would not be a great deal of trouble to make them yourself.

The Editor invites subscribers to communicate their automobile troubles and personal experiences, stating them clearly on one side of the paper. If the nature of the case permits, send a sketch, even if it be rough, in order to assist to a clearer understanding. Each communication will receive attention in the order of its receipt, if the writer's signature and address accompany it as an evidence of good faith. If the writer objects to the publication of his name, he may add a nom de plume.

## More Acetylene Gas Trouble

EDITOR THE AUTOMOBILE:

[2,939]—I have had considerable trouble with the gas supply for my headlights. They frequently sputter and go out when I am on the road and I find it necessary to blow out the piping in order to rid the system of water before I can get them to burn again. Is there any way to prevent this water from getting into the piping? I use an acetylene generator.

M. E. LONG.

San Francisco, Cal.

The way to rid the system of this water is to slant the gas piping down to a condensation trap. This trap should be drained occasionally in order to remove the accumulated moisture. It is a good plan to blow out the piping with a pump from time to time also. In our issue of November 9, on page 817, will be found an illustration showing a trap of this kind in place.

## Horses vs. Motor Trucks

EDITOR THE AUTOMOBILE:

[2,940]—As a subscriber to your valuable magazine, I wish to ask if you can furnish any data regarding the relative cost and saving between a motor truck and a horse-drawn vehicle. Any figures that you may be able to furnish will be greatly appreciated.

CHAS. F. MACKIN, JR.

Newark, N. J.

Any data that could be given in this connection would be of little or no value, as the conditions under which motor trucks are operated vary widely. The question of care in operation would also enter, thus involving the human element. When the speed and carrying capacity of the average large motor truck are compared with those features of the horse-drawn vehicle the former would seem to have sufficient advantage to counterbalance its increased first cost and expense of maintenance.

From figures covering over 1,000 gasoline trucks, it has been found that the operating expense is about 6 cents per ton mile, while for the same number of electric trucks this item becomes 7 cents per ton mile. These figures are exclusive of drivers' wages and garage expense.

## Universal Joint Loss

EDITOR THE AUTOMOBILE:

[2,941]—What is the loss of power in the ordinary universal joint used in automobiles between the engine and the rear axle?

H. L. WOODRUFF.

Anderson, Ind.

The loss to which you refer does not ordinarily exceed 5 per cent. It will depend entirely on the angle at which the shafts are working. The greater the angle between the axes of the shafts, the greater the loss.

## Tire Pointers

EDITOR THE AUTOMOBILE:

[2,942]—In reading through your October 19th issue I noticed a letter in which one of your subscribers asked whether letting out the clutch in turning corners saved the tires. In your answer you stated that it did, and that there were a number of other little ways in which the driver could save on tire expense. Would it be possible for me to hear from you with reference to any of the "other little ways"? I do not care how brief your information may be, as the mere suggestions will aid me considerably.

SIDNEY W. SALOMON.

New York City.

There are many other suggestions which might be offered as to the best ways of lowering tire expense, among them being to refrain from applying the brakes too hard or too suddenly, causing the tires to slip along the pavement or road and wearing them unnecessarily. Further, never run on a flat tire if possible to prevent it, as this is sure to rim-cut the shoe, often rendering it useless. Do not allow the tires to stand in oil or grease, and keep them free from rust along the beads where they come in contact with the rims. Rust eats into the rubber in a short time. Do not run in large ruts and avoid straining the shoes by hitting rough places at high speed. When drawing up to a curb, be careful not to snag the shoes against the stone.

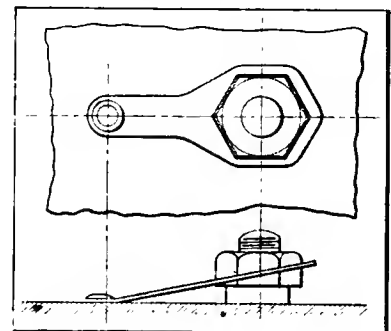

Fig. 2—A good nut-locking device

Support the Rod

Editor THE AUTOMOBILE:

[2,943]—There seems to be a good deal of play and a tendency to sag in the rod which runs from the ball-and-socket joint below the steering column to the steering knuckle arm on my car. I have tightened this rod up as much as possible but it still rattles when the car is driven. Can you suggest any means of preventing this?

J. R. DAY.

Allentown, Pa.

The thread is evidently worn, and it would be wise for you to have the rod replaced, as it is not advisable to risk any mishap to the steering gear. A leather strap support for the side-rod, as shown by Fig. 3, is sometimes used, and no doubt this would stop the rattle to which you refer, at the same time preventing the sag of the rod and the excessive wear on the thread. This strap should be fastened somewhere near the ball-and-socket joint, as shown.

Radiator Drain Cock

Editor THE AUTOMOBILE:

[2,944]—How can I get the water out of my radiator? In laying up my car for the winter I want to drain the water from the motor, but there seems to be no provision for doing this. Will you please tell me where the drain cock is usually located, as I may conclude to have one put on.

C. J. ANDREWS.

Morton, N. Y.

Most cars have a radiator drain cock located, as shown by Fig. 4, in the water outlet pipe at the bottom of the radiator. If your car is not provided with a drain of this kind, you should either fit one to the pipe yourself, or have a repairman do it for you. No car should be without such a fixture, as it is often necessary to draw off the water from the cooling system for one purpose or another.

Engine Ratings

Editor THE AUTOMOBILE:

[2,945]—As I am a subscriber to your valuable magazine, I want to ask a question to determine in my mind the different horsepower values of different bores of engines. For instance, a 3 3-4-inch by 4 1-2-inch motor is rated at 25 horsepower; one 4 1-8 inches by 4 1-2 inches is rated at 35 horse-

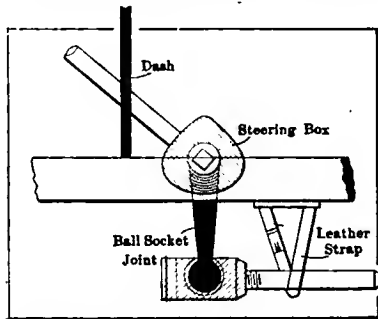

Fig. 3—Strap support for steering side-rod

power; one 4 inches by 4 1-2 inches at 30 horsepower, and one 4 3-8 inches by 4 1-2 inches at 45 horsepower. How can a motor jump, say, 10 horsepower on an increase of only 1-4 inch in bore? Please explain and give me the table of different bores. Do they change the gears to make this difference? If so it must kill the speed of the car.

J. A. CROUP.

Graysville, O.

The rated horsepower of a motor does not depend solely on the diameter or bore of its cylinders. There are several other factors which enter into this rating. The cylinder bore, piston travel per stroke, number of explosions per minute and the explosion pressure are all taken into account in computing the indicated horsepower of a motor. The formula used is as follows:

PLAN

$$IHP = \frac{P \cdot L \cdot A \cdot N}{33,000}$$

in which IHP is the indicated horsepower, P is the explosion pressure acting on the face of the piston, L is the length of piston stroke in feet, A is the area of the piston in square inches (which involves the cylinder diameter) and N is the number of explosions per minute (usually equal to half the number of revolutions per minute in a four-cycle engine). This is the exact method for determining the rating and it will be seen that two motors of the same bore might have widely different horsepower. For purposes of comparison the A. L. A. M. rating for engines is usually employed. The formula adopted is  $\frac{D^2 N}{2.5}$ . D is the cylinder bore

in inches, N the number of cylinders and 2.5 a constant, based on the average view of the A. L. A. M. engineers as to a fair conservative rating for a four-cycle motor at 1,000 feet per minute piston speed. This, however, is merely comparative and in a great many cases does not come very close to the actual power of the motor. Based on this latter formula, there is a table of cylinder bores with corresponding horsepower values published by the A. L. A. M.

The gears have nothing to do with the rating of the motor.

Desire to Start Club

Editor THE AUTOMOBILE:

[2,946]—The automobile owners in our locality are preparing to organize a club for the purpose of bettering road conditions and erecting signs along the road for the guidance of drivers. I thought it possible that I could secure information through your columns where we could get some data as to by-laws and other matters pertaining to the formation of such an organization.

A. P. ODE.

Calmar, Iowa.

If you will address the American Automobile Association, 437 Fifth Avenue, New York City, the desired information will be gladly forwarded to you.

Care in Laying Up Cars

Editor THE AUTOMOBILE:

[2,947]—Would you kindly give me a remedy to prevent the rusting and damaging of my radiator and water cooling system while my car is out of service, as I have put it away for four months?

Wallace, W. Va.

J. B. MOORE.

In laying up your car for the winter the cooling system should be drained of all the water by opening the drain-cock at the bottom of the radiator. Then the motor should be started and run for a minute or so to dry up any moisture which may still remain in the system. Of course care should be taken not to heat up the motor in doing this.

The gasoline should also be drained from the tank, and the car should be jacked up and rested on blocks or horses in a substantial manner so that the tires may be deflated to a low pressure. It is even better to remove the tires, wash them care-

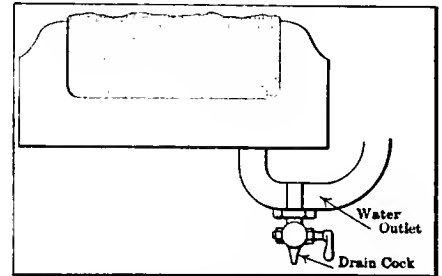

Fig. 4—Showing drain cock in water outlet

fully, wrap them in strips of paper or cloth and store them in a dark place the temperature of which is as nearly constant at about 50 degrees as possible. If the wheels are not jacked up the tires are apt to flatten from standing too long on one spot.

Not Very Far

Editor THE AUTOMOBILE:

[2,948]—Apropos the anti-freezing mixture discussion, how far could a four-cylinder automobile go with impunity without water in the radiator in zero weather, also in freezing weather when the temperature is about 32 degrees Fahrenheit. I am speaking, of course, relative to water-cooled cylinders.

GREENHORN.

Cleveland, O.

While we have not heard of the experiment being actually carried out, the automobile would run just long enough to allow the cylinders to get red hot, the lubricant to burn up, the pistons to seize and the wristpin bearings and others to burn up. In a word, a water-cooled motor should never be allowed to run for more than a minute or two without water circulating properly through the cooling system, if serious results are to be avoided. The high temperature within the cylinders makes it necessary to carry the excessive heat away by means of an effective circulation of water through the jackets, even in the coldest weather.

# Little Bits of Motor Wisdom

## Pertinent Pointers of Interest to Repairman and Driver

**R**EMOVING GEARS FROM THEIR SHAFTS—Often it is very difficult to remove magneto or camshaft gears which are fastened to the shafts with keys, or which have been sweated on, especially if they have remained in place for a considerable length of time. Occasionally the shaft is bent, due to the force exerted when the gear is driven off from one side in the usual manner with hammer blows on the end of a rod or other tool, which, in turn, is held against the hub of the gear. A very good method for the removal of these gears is shown by Figs. 1 and 2. Two views of the tools used are shown at A and B, Fig. 1. These tools can be made of any pieces of steel which are handy, or out of an old file or two. The space between the prongs need not be over an inch to an inch and a quarter for use in connection with camshafts

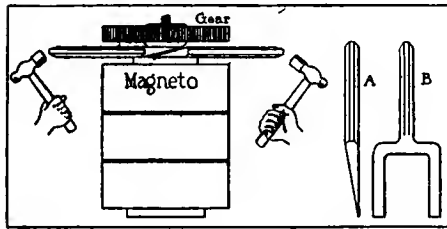

Fig. 1.—Removing magneto gear and the special tools to use

and the like. It should be wide enough to easily clear the diameter of the shaft. The prongs should be tapered from a point at the ends to about three-eighths of an inch at the thickest parts, and they should be about two inches long. For removing a magneto gear, two of these tools are used, as shown by Fig. 1. They are placed back of the gear with their tapered parts in contact, and are driven toward the center with hammers. The wedging action lifts the gear from the shaft. Fig. 2 shows the same tools being used for the removal of a camshaft gear. In this case the shaft is placed in a vise with the gear hub close to the jaws. The tools are then driven in between the tops of the vise jaws and the gear hub in the same manner as before. It should not be necessary to strike very heavy blows with the hammers, although sometimes these gears are very firmly fastened to their shafts.

**FLAME PROPAGATION.**—The internal expansion engine such as is used in automobiles is peculiar in that the expanding gases which drive the piston are heated directly within the cylinder. The ideal condition in

any motor is to attain the highest possible mean effective pressure, this being not only true in the gas engine but in all engines which are operated by means of a cylinder or other expansion chamber. The indicated horsepower of an engine depends directly upon the mean effective pressure and, all other things being equal, will vary directly with that factor. It is not an easy matter to determine the mean effective pressure within the cylinder of a gasoline motor without an extensive apparatus, but the various conditions which affect it are well known so that in the design of the motor it can be varied to any degree required within practical limits. There are two conditions which are of the greatest importance in fixing this quantity; one of these is the compression and the other the rate of flame propagation.

The amount of compression is easily determined by the volume of piston clearance left within the cylinder after the piston has reached the highest point in its stroke or the upper dead center. The rate of flame propagation is affected by a variety of features in the construction of the engine and the condition and quality of the gas which is within the cylinder. The current theory as to the propagation of the flame in the cylinder of a gas engine is that the flame spreads in all directions at the same rate of speed through a quiescent mass of gas. This condition is approached more or less in the cylinder of a gas engine, although it cannot be ever entirely the case owing to the presence of some of the dead gases of the previous explosion in every automobile motor.

In any gas engine cylinder there is a given quantity of gas which will have to be ignited and burned, and the sooner this charge is burned in relation to the stroke of the motor the less chance there will be for any of the unburned gas to escape with the exhaust products and the sooner, in relation to the stroke, will the maximum pressure be reached. Since it takes a definite and fixed length of time to burn each similar charge within the cylinder of the gas engine, the sooner the gas is completely fired the further will it have progressed in its period of burning and expansion and the lower will be the terminal pressure. The pressure of the gases on exhausting is just so much thrown away, and hence the necessity for producing conditions which tend toward rapid combustion and flame propagation. It is for this reason that a perfect mixture is a condition which is to be desired, since either a lean or rich mixture

will fire much more slowly than a perfect combination of gas and air. The mean effective pressure is governed by the position of maximum pressure of the indicator card and the pressure at exhaust, and, as is pointed out above, the sooner the maximum pressure is attained with reference to the stroke of the engine the lower will the terminal or exhaust pressure be.

The propagation of the flame is much more rapid if it is allowed to start in all directions at once, and it is for this reason that it is not good practice to have the spark concealed behind a wall or in a pocket. The rapidity of flame propagation is also affected to a great extent by the pressure of the gases. This is another point in favor of high compression, as a gas which has been compressed to the extent that is common in the automobile engine cylinder will burn very rapidly and hence will attain its maximum pressure very early in the stroke. It has not as yet been possible, however, in spite of the high compressions to attain a perfect combustion of the gasoline in the cylinder, hence a large amount of combustible material will also be found in the exhaust products.

**PISTON RINGS.**—As is well known, one of the greatest sources of loss of power in a motor is the leak of the compressed gas past the piston rings. This leak may be due to the fact that the cylinder is out of round,

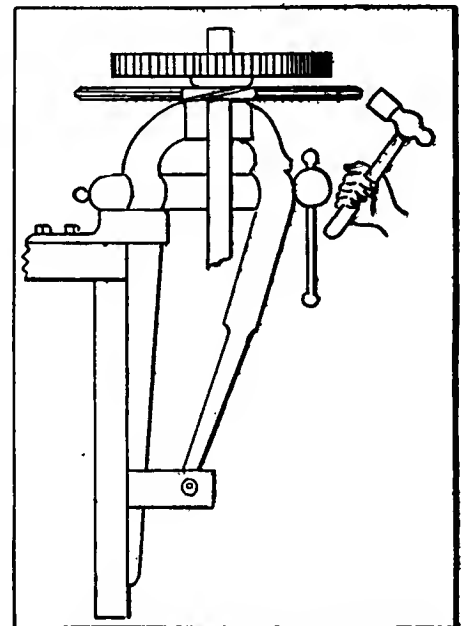

Fig. 2.—A camshaft gear can be taken off in much the same manner

it may be due to the rings being worn, or to their being ill-formed or designed. In the modern motor, the rings are almost invariably of the eccentric type, that is, their thickest part is opposite to the point where they are split to admit of their being sprung over the pistons and into place. The metal is thinnest at the joints. The theory

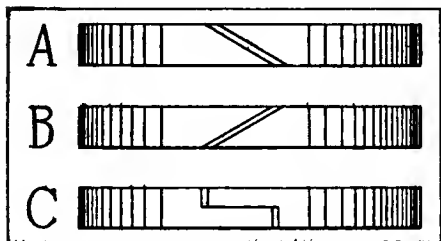

Fig. 3—Rings with lap joints are best

involved in their design so as to get the correct eccentricity is rather exhaustive, but the reason for their being made this shape is that, when the ring is in place, it will, theoretically, expand equally and exert the same force in all directions against the cylinder wall. Circular rings will not do this, but will have the greatest tendency to spread out at the point where they are split. This causes leakage, and, hence, this form of ring has almost entirely been abandoned in favor of the more correct, yet harder to make, eccentric ring.

The usual ways in which rings are split are shown by Fig. 3. At A and B are shown diagonal cuts, but the best form is seen at C. It is easier for the gas to get through the diagonal joints than the lap joint, as the angles of the latter offer more resistance to its passage.

Many motorists may think points of this kind of little importance, but if it is ever found to be necessary to replace worn or broken rings, the lap joint ring should be used in preference to the other. Much time has been devoted by automobile experts and engineers to this particular seemingly small item of design, and it is on account of just such refinements that the representative motor of to-day is as perfect and reliable as it is.

**WHEN REPLACING GASKETS.**—Care should be exercised in renewing worn-out gaskets so that the packing is not cut smaller in internal diameter than the holes, thus partially or wholly obstructing the passages. In cutting gaskets, the best way to go about it is to take the part which has the clear holes for the bolts or screws and support it firmly in a vise or in some other manner. Take the material from which the gaskets are to be made and lay it smoothly over the opening, where the gasket is to go, and with the ball peen of a hammer tap it lightly around the edge of this opening. This marks the rubber or other gasket material with the exact outline which the gasket is to have, and it is then a simple matter to cut the correct shape. If the gasket material is very thin, this tapping

around the edge with a hammer will usually cut the desired shape immediately, and will make a very good job. In case copper or other thick material is to be used, the hammer makes the outline and the gasket can then be cut out accurately by the use of shears, chisels and punches. Gaskets made in this way are more accurate, and there is less possibility of their being out of shape so as to clog the joints.

**PIPE BENDER USEFUL.**—It is often found necessary to bend a pipe so as to make it accommodate a desired space, or so that it will lead in a different direction. Pipe benders of different sizes are manufactured for the purpose, and several of them should be included in the garage equipment. Fig. 4 shows a form of bender, which is made up of a coil of wire, slightly tapered at one end so as to be readily removable after the pipe has been bent to the desired shape. The pipe is first heated so as to be easily worked, then the proper size bender is inserted in it, and the pipe bent over a form. The bender prevents the pipe from flattening out at the bend, and preserves its

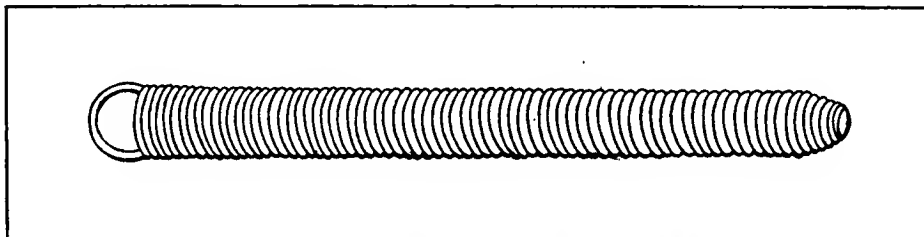

Fig. 4—Pipe benders are sometimes useful in the garage

circular form. After the operation the bender is withdrawn and the pipe allowed to cool.

This tool is sometimes useful in fitting manifolds and their immediate piping, also for attaching cooling-water pipes. There should be as little obstruction to the passage of the water or gas as possible, and bad bends where the pipe is flattened should be avoided, as they do not admit of free passage and increase the fluid friction.

**THE CONE CLUTCH.**—Cone clutches are of two types, the internal and external. The external clutch is one in which the flywheel forms the female member and the male cone is forced into it by means of a spring or springs; this is the most common type of clutch in use to-day; it is the simplest to manipulate and the adjustments are easily made. The clutch is comparatively inexpensive and any repairs which have to be made will generally be in the nature of refacing the clutch with new leather or of simply treating the leather with which the clutch is fitted. By allowing a leather-faced clutch to slip too much, a glaze is imparted to the facing which spoils the engagement; in fact, in many cases where this glaze is excessive the clutch will either not take up at all or will

take up so fiercely that the occupants of the car will be violently jerked about.

Leather can be made to give better service by applying a dressing. The leather of a clutch is the same as the leather of a shoe in that it will need occasional dressing to keep it in condition. A shoe which is never dressed soon acquires a hard, brittle condition which can only be remedied by the application of a softening compound. The dressing to be applied in the case of the leather-faced cone clutch is neat's-foot oil. The clutch leather will absorb this preparation readily at first and several applications should be given with the clutch pedal blocked out so that it is disengaged. When the leather appears to be well saturated allow the clutch to stand disengaged for the night and it will be found that in the morning the leather will have become greatly rejuvenated and regained a large amount of its lost flexibility.

With a leather-faced cone clutch easy engagement is often obtained by inserting springs beneath the surface of the leather. The springs are either of the coil type or are flat. When the coil springs are used they are generally placed on the inside of

the cone and are used in connection with plungers which pass through the cone and press against the inner surface of the leather. When the flat springs are employed they are generally fitted in a recess in the metal cone beneath the surface of the leather, and when fitting the leather they are sprung. They bear constantly against the surface of the leather and lift it in spots. There are about twelve of these fitted on a 16-inch clutch.

A clutch brake is often fitted with this type of clutch so that it will be automatically applied when the pedal releasing the clutch is pressed down. This will greatly facilitate the changing of gears. It is very essential in the life of the clutch that the car should be started on the lowest speed and then gradually brought up to the highest speed so that there will be no tendency to slip.

**CARRY A SMALL BOARD WHEN TOURING.**—Many times when on the road it is necessary to jack up a wheel for one reason or another. A small piece of 2-inch by 4-inch board about a foot long will then come in very handy to stand the jack on, especially if the road is muddy, or the ground very soft. This also serves to make the jack higher and gives it a greater height of lift.



# My Best Automobile Repair

## Some Quick Repairs Made in the Garage and on the Road

### A Difficult Repair

EDITOR THE AUTOMOBILE:

Perhaps some automobilists would hesitate to undertake the repair which I have shown by Fig. 1, but I did not have a great deal of trouble doing it, and perhaps some of your readers would be interested. Two of the teeth on one of the timing gears became damaged, and, as there was no repair shop handy, I made the repair as shown. The face of the wheel was dovetailed out, and then a bronze casting, B, was made, having approximately the shape of the teeth and the dovetail at the bottom. This was driven into the recess in the gear face. Next a template was made from one of the good teeth A, and the rough cast teeth B were then filed to conform with it. Holes were then drilled and tapped into these new teeth, and two set screws D were put in, the metal strip C being interposed between their heads and the gear. Of course, this repair would be harder to make if the gear were of steel in place of the softer bronze.

C. K. AIME.

Lansing, Mich.

### Use of Old Casings

EDITOR THE AUTOMOBILE:

I have been very much interested and have found many valuable suggestions in your automobile repair articles. In the issue of November 23 A. D. Hard gives some good pointers as to the use of old casings.

I have found it very hard to spring any kind of a complete casing over another one. Tears from tire-irons, especially on old casings, will inevitably occur. My method is to build up an old casing from the inside, filling in all irregularities and cleaning both casings, as suggested by Mr. Hard. Then make a copious application of cement to one-half of the inner side of the casing which is to be used outside. Kink the one to be used inside by grasping the beads with both hands and pulling outward and upward at the same time, using counter pressure with the knee. This causes the inner

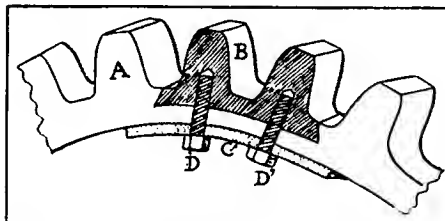

Fig. 1—Showing method of replacing damaged gear teeth

*Temporary automobile repairs made by the driver or owner while on the road and permanent repairs made in the garage after the run is over, are interesting to all automobile owners.*

*It may be a spring leaf has broken; a shackle bolt or strap may break; a steering tie rod is bent; the car skids into a curb and bends a steering arm or the starting crank; a throttle or magneto connection breaks owing to vibration; a radiator leak is started by a stone or some other means; a leak in the gasoline tank is discovered; there is a small hole in the gasoline feed line; a brake facing may burn out; a brake connection breaks; a front axle gets slightly sprung; a clutch starts slipping, or any one of a thousand things may happen.*

*Every automobile owner is interested in knowing how repairs have been made, how long it took to make them, how much they cost, and by whom they were made.*

*We want you to write in simple language in a letter what repair of this nature you have had to make, how you made it, how long it took you and how much it cost.*

*You can make with your lead pencil one or two rough sketches indicating the broken or damaged part and showing how the repair was made.*

*The experience of each reader is interesting to every other reader. Analyze your past experiences and send in one or two of them.*

*Give your name and address, legibly written. If you do not want your name to appear, make use of a nom de plume.*

Editor THE AUTOMOBILE.

casing to look like an inverted bar horse-shoe. While holding the inner casing kinked as described, have an assistant apply a coating of cement to the circular part and place it within the debeaded outside casing. Then carefully allow the inner casing to spring back into its original shape, at the same time working it into the outer casing. The cement can be readily applied between the uncemented portions; then, if too much of the bead has not been cut off, a remnant of it will go under the rim.

Put the casing on the wheel immediately, and apply ten pounds pressure to the tire for a half-hour. After that time, inflate the tire to its normal pressure and keep the wheel jacked up for at least 48 hours, in the meantime wiping off any exuding cement and pressing with the fingers at any places along the bead edges where there is a tendency for separation.

In all tire repair work by amateurs sufficient time is not allowed for drying before use. I have found the slow drying rubber fillings much more permanent than the quick drying ones. The first mentioned kind takes two or three days to dry, but it does not crack and makes one continuous filling, while the latter kind cracks and works out.

### Scavenging the Cylinders

I have another hobby. I always descend hills with the clutch in the desired speed and the batteries off, thus allowing a full charge of gas to circulate through the engine and muffler. This cools the engine, cleans the combustion chambers and exhaust valves and softens up the carbon in the muffler.

If the spark is well advanced and the

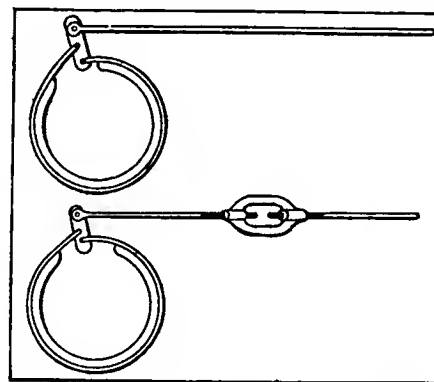

Fig. 2—Turnbuckles are easily attached to the brake-rods

throttle opened wide on an immediately succeeding level stretch most of the carbon will be burned out of the muffler.

I also invariably speed up my engine on stopping, even if I do not intend to start on compression. This forces all dead gases out of the cylinders, since by throwing the gears into the neutral and shutting off the engine the flywheel turns it over and forces new gas into the cylinders. Dead gas, standing, will usually precipitate solid carbon.

"MOTOR WOULD-BE-WISE."

Plymouth, Pa.

### Put on Turnbuckles

EDITOR THE AUTOMOBILE:

I have an old car which formerly did not have provision for the adjustment of the brake-rod tension. I decided to put turnbuckles on these rods, as shown by Fig. 2. I cut the rods in two at the middle with a hacksaw, then took out about an inch of each rod, so as to allow for the adjustment. A thread cutting die was then procured and a male thread cut on one end and a female thread on the other. I then had two turnbuckles cast, and the same number of threads cut in them as on the rods. After applying them to the rods I found, of course, that the efficiency of my brakes was very much increased.

Dubuque, Ia.

C. P. ROGERS.

# My Ideal 1912 Automobile

## Readers' Conceptions of What Next Year's Car Should Be

### Rather Dreamy

EDITOR THE AUTOMOBILE:

My conception of a modern motor car will certainly come in the class of "ideal," but the mark of 1912 will hardly apply, as it is rather doubtful if my car will be on the road before 1915.

The motor of this car will be of six cylinders cast in pairs, operating on a two-part cycle. The crankshaft is carried on four large plain bearings and is drilled for lubrication under pump pressure. Two fly-wheels will be used, both of small diameter so as to allow the motor to be set very low in the frame and still have ample clearance. The rear fly wheel will house a dry plate clutch consisting of a small number of large size plates, each pair of which is separated by a friction member which takes the wear and is easily renewed. The front fly wheel is not attached direct to the crankshaft, but is driven through a multiple disc clutch held in engagement by a spring of such strength that at certain engine speed a slight slippage will occur which will dampen the periodic vibrations common in most six cylinder motors.

Each cylinder is of the two piston design, the upper power cylinder having a bore of four inches and a stroke of six inches. The lower charging cylinder is of such size as to have a volume slightly in excess of the power cylinder and connecting passage. Pure air only is drawn into the charging cylinder from the crankcase. This tends to muffle the noise of air induction, produces a slight vacuum in the crankcase which prevents oil leakage, heats the air slightly and charges the air with an oil mist which will be sufficient lubrication for the charging cylinder. The compressed air charge is conducted to the adjacent power cylinder of the pair through a combined rotary valve and passage way. One valve is used for each cylinder, two being placed in each block on opposite sides between the cylinders. These valves are operated through worm gears by two secondary shafts driven by a single silent chain from the crankshaft. The upper end of each valve extends through the top of the cylinder casting and carries a cam which operates the fuel pump atomizer for that cylinder. The strokes of these pumps are adjustable from zero to maximum, and are controlled the same as with the usual throttle. The ignition system is double throughout, except the dynamo, and both operate all the time. The dynamo, which also supplies current for the car lights, is driven by silent chain from the rear end of one of

*Readers continue to demonstrate their interest in the ideal car and the specifications which are submitted show a wide range of taste and requirements. In view of the interest shown the Editor continues to extend the invitation to all who entertain ideas on this absorbing topic to submit their opinions for publication. The description should be legibly written on one side of the paper and signed by the sender, although if it is so desired the name will not be published.*

the secondary shafts. Current is kept constant by means of a governor which instead of controlling the speed of the armature controls its position in the field. As the speed of the motor changes, the armature is shifted in and out of the field. When the motor is stopped this governor automatically switches on the current from the storage battery to supply the lights.

The cooling of this motor is through a new type of radiator carried on the dashboard, the hood of this car being of the Renault, or, more properly, the Franklin type, as there is no radiator visible from the outside. By means of a mercury pressure regulator, the temperature of the cooling water runs to about 300 degrees before boiling, which adds greatly to the efficiency of the engine. Water circulation is by a thermo gravity system, as the bottom of the radiator is well above the bottom of the water jackets.

The excess compressed air is carried in a tank and used for starting the motor and inflating tires. The gear box is carried on the rear axle and is "nearly gearless," as only two gear sets are furnished, one for reverse and one extra low for extra hard pulls, starting on direct drive being possible with this flexible motor.

Brakes are of the multiple disc type, carried in the rear wheel brake drums, and operated by the two foot pedals. No brake lever is used and the speed change lever is carried in the center of the car.

The wheelbase of this car will be about 120 inches, with tires 36 x 5.

Any standard body will be fitted to suit the user.

Accessibility, ease of replacing wearing parts, comfort for the passengers, noiselessness and high motor efficiency are points striven for in this ideal car.

GUESSER.

Brocton, Ill.

### Desires Interchangeable Body

EDITOR THE AUTOMOBILE:

In my opinion, the ideal automobile for 1912 would be a six-cylinder, 40 horsepower

car, weighing about 3200 pounds, and fully equipped with top, lamps, tools, horn, baggage rack, tire irons, speedometer and clock.

The motor would be either of the valveless type or it would have valves in the head, with the valve-springs enclosed. The carburetor would be of the double-jet type with an auxiliary air valve, adjustable from the seat. The cooling system would consist of a cellular radiator of ample size, gear-driven pump and gear-driven fan. Ignition would be by means of a storage battery and Bosch magneto with two sets of spark-plugs. The splash system of lubrication with auxiliary force-feed to the crankcase would be used. The transmission would be of the selective type, four speeds forward and reverse, with direct drive on high. Shaft drive with bevel gear would be used, and I would have both internal expanding and external contracting brakes on the rear hubs. I would want the brake-bands so arranged as to be readily adjustable and all parts of the braking mechanism accessible.

As for the body, it would be arranged with the driver's seat on the right. Several bodies would be part of, the equipment, and they would be made to fit the same chassis, so that touring car, roadster, phaeton, limousine, coupé or landaulet could be used as desired.

The wheels would be made for 36-inch by 4½-inch tires, and the rims would be quick detachable. The springs would be semi-elliptic, and there would be shock-absorbers attached. I would want a B. & L. Castor front axle, so as to make driving easier and safer. The steering gear would be irreversible, of the worm and sector type.

This car would not be very expensive, if made in sufficient quantity.

F. G. ENSON.

Newburgh, N. Y.

### Specifies Two Mufflers.

EDITOR THE AUTOMOBILE:

My idea of a 1912 automobile is as follows: Knight motor, bore 2½ inches, stroke 7 inches, four cylinders, underslung frame, 122-inch wheelbase, 38-inch by 4-inch tires, four speeds ahead, four-passenger body with plenty of room in the tonneau, full floating axle, 20-inch by 2½-inch brakes, tires carried under the back seat. I would also have two mufflers, one alone to be used in the country and the two together where absolute silence would be desired.

SHERMAN FAIRCHILD.

Oneonta, N. Y.

# Automobile Metallurgy Made Easy

By E. F. LAKE

## Part III

### Elongation and Reduction of Area

(NEXT WEEK—TORSIONAL STRAIN)

**E**LONGATION, which is sometimes called extension, and reduction of area, which is sometimes called contraction, are also important factors that are shown by the tensile testing machine. When a test bar is pulled until it is

broken, it stretches or elongates. This elongation is always given in percentage. A certain gauge length is taken as a unit. The distance that the specimen stretches beyond this, from the time pulling is started until the break occurs, is figured as the percentage of this unit, and this is called the percentage of elongation. The elongation up to the elastic limit is very slight in most metal and does not indicate any particular property of importance; it is also difficult to obtain. Two inches on the length of a test bar has generally been accepted as the unit from which to figure the percentage of elongation for automobile materials. For some other uses, and in some other places, 8 inches has been standardized as the unit.

Elongation gives an idea of the plasticity and ductility of metals. While these are properties that may be beneficial in some places and for some kinds of work, they have very little place in automobile construction, unless it be for bearings or in places that require very little strength or stiffness. As plastic means softness in metals, those that are plastic are easily forced out of shape and they would have a high percentage of elongation. Ductility means that metals can be easily drawn or twisted and thus forced out of shape, whereas stiffness is what is required of nearly all automobile parts.

A certain amount of elongation is necessary, however, as this would indicate properties that overcome brittleness. As a rule, the greater the percentage of elongation, the less will be the brittleness, and vice versa. For instance, high carbon steel that has been hardened in water or brine, would have hardly any elongation and be so brittle it could easily be broken by a sharp blow. Such steel might even have a very high tensile strength and elastic limit, but as there is no give to the metal when the blow is struck, it is fractured, being a great deal like glass. If the same steel were thoroughly annealed, or softened, it would have a comparatively high percentage of elongation with very little brittleness and thus be very difficult to break.

For most parts of the car, therefore, it is necessary to have some elongation in the metals, but this elongation does not want to be anywhere near that shown by a rubber band. If it were the metal would be practically useless. Elongation

is the least important of the four properties shown by the tensile machine. On account of the elongation shown by such materials as rubber, many metallurgists are claiming that it should be ignored when testing steels and reduction of area or contraction be made the real important property of these two.

Reduction of area is a phenomenon that always accompanies elongation. In pulling test bars they do not elongate throughout the whole distance of even the 2-inch length that the percentage is figured from, but the stretching is confined to a small space. Nothing is added to the volume of metal as the specimen is stretched and consequently its original diameter is reduced. The

cohesive force, which binds the molecules together, causes them to flow toward the center of the test bar and reduce it in diameter while it is being stretched out lengthwise. The shape that these test bars take at the break is shown in Fig. 1. This shape varies considerably, however, as some metals might elongate considerably and not contract very much; others might contract a great deal and not elongate very much.

The cohesive force varies considerably in different metals or alloys and hence there is no uniform ratio between the elongation and the reduction of area. For instance, a large elongation over a short distance in the specimens length, might only show a comparatively small reduction of area owing to the cohesive force not drawing the molecules as closely together as it would in other specimens, or other metals.

This contraction or reduction of area is also figured in percentage. The area across the original test bar before breaking is taken as the unit on which to figure this percentage. The amount that this area has been reduced, at the point of breakage, is then figured as the percentage of this unit, or the percentage of the reduction of area.

The reduction of area shows the toughness, density, hardness and cohesion of metals and, therefore, is a very important factor in judging their mechanical properties. In fact it is one of the most important of the four properties shown by the tensile machine. If the figures for the elastic limit and the reduction of area can both be made high in one piece of metal, it is the ideal condition to attain. As an instance of this, one gear maker said, "An ideal carbon steel for transmission gears is one that would have 85,000 pounds elastic limit, with a reduction of area of 45 per cent." Either one of these figures is easy to obtain in these steels, but it is difficult to find a brand or to so work it mechanically and heat treat it that both figures will be obtained.

Heat treatment affects the percentage of elongation and reduc-

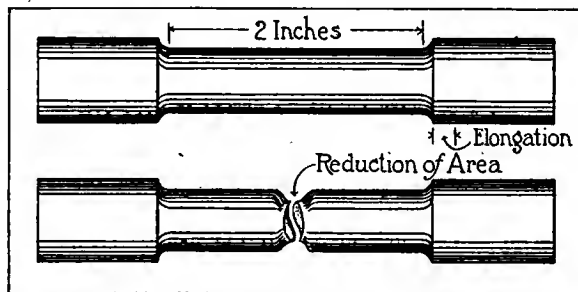

Fig. 1—Test bar before and after it was pulled apart

HEAT-TREATMENT.	PERCENTAGE OF	
	Elongation.	Reduction of Area.
Annealed at 1475° F. . . . .	29	59
Quenched in brine from 1650° F.	4	16
Quenched in oil from 1650° F.	9	32
	12	41
	17	57
Drawn at	18	65
Various Temperatures	17	62
	20	68
	21	66

tion of area, as well as the tensile strength and elastic limit. It affects these, however, in diametrically opposite directions. That is to say, when steels are hardened, their tensile strength and reduction of area are raised. Then the metal is very hard and shows a high strength when given a straight pull. The low figures for elongation and reduction of area show that the metal has lost nearly all of its plasticity and ductility as well as its toughness and density. It would, therefore, break easily if given a sharp blow or if bent, or twisted. By drawing this hardness, as in tempering, the percentage of elongation and reduction of area is raised, bringing back some of the ductility and toughness, while the tensile strength and elastic limit are lowered, thereby reducing strength in that direction.

The effect of heat treatment on the elongation and contraction of a nickel steel is shown in the table. The action on the tensile strength and elastic limit was given in my preceding article entitled Elastic Limit. Pieces that go into the various parts of an automobile must be heat treated in a manner that will make them withstand strains. Almost all the pieces are treated differently in this regard as their work is different.

### Glycerine in Steel Treatment

Intermediate grades in the hardening of steel, especially tools, are difficult to control, as oil does not mix with water and the method of floating a layer of oil on top of the quenching bath gives indifferent results, while quick dipping in oil followed by complete cooling in water requires considerable skill and does not always produce the results aimed for. In practice the degree of hardness imparted to the cutting edge of a tool is either that produced, in the grade of steel used, by quenching in oil or that produced by quenching in water. Higher degrees of hardness may be produced by using brine and by other well-known means, but the considerable range of variations in hardness while lies between oil and water quenching is not under effective control. The use of several different kinds of oil, such as rape seed and

fish oil, of different fluidity and conductivity, is a complication in the ordinary shop, and cooling by air-blasts of varying intensity is applicable to high-speed steels only. In this situation, the use of glycerine instead of oil recommends itself, as it is miscible with water in all percentages and also readily receives those admixtures of salt and acids which may be desirable for graduating the hardening effect of the bath. And this substance has been found to impart to the bath exactly the same qualities which characterize oil. It softens the temper and obviates distortion of the hardened article.

While no formulas good for all requirements can be given, anybody familiar with hardening work can readily find for himself the admixture of glycerine which suits his special purposes, just because the admixture may be made in any desired percentage. Guiding examples may be offered, however. For a medium average hardness, a bath as the following may be found suitable to start with: Glycerine, 8 kilograms; water, 10 kilograms; cooking salt, 1-2 kilogram; sal-ammoniac, 100 grammes; concentrated hydrochloric (muriatic) acid, 50 grammes. And for a bath producing sharp hardening 66 weight parts of glycerine with 100 parts of water, 18 of sal-ammoniac, 24 of cooking salt and 2 of alum may be tried. The baths should always be stirred before first using, to make sure of uniformity.—From *Metall-Technik*, October 14.

**FROSTED CARRIAGE WINDOWS**—In the winter the windows of a closed automobile draw moisture from the respiration of the occupants and easily freeze up or at least become clouded with vapor. Two simple ventilators, one in each upper corner of the vehicle, to the rear, reduce this annoyance and cause no drafts.—From *La Pratique Automobile*, Nov. 10.

It is mentioned in *The Auto* (London) of November 18 that "Antimist" is a preparation supplied by Dunhill's for the same trouble, with special reference to windscreens and goggles. It is a waxy substance put up in the form of a pencil, which is rubbed on the glass. The latter when polished regains complete transparency, but sheds mist.

## Calendar of Coming Events

### Shows

Dec. 30-Jan. 6.....Buffalo, N. Y., Annual Show, Seventy-fourth Regiment Armory, Buffalo Automobile Trade Association.  
 Jan. 2-11.....New York City, Hotel Astor, Importers' Salon.  
 Jan. 6-13.....New York City, Madison Square Garden, Twelfth Annual Show, Pleasure Car Division, Automobile Board of Trade.  
 Jan. 6-20.....New York City, Madison Square Garden, Annual Show, Motor and Accessory Manufacturers.  
 Jan. 10-17.....New York City, Grand Central Palace, Twelfth Annual Show, National Association of Automobile Manufacturers; also Motor and Accessory Manufacturers.  
 Jan. 13-19.....Milwaukee, Wis., Auditorium, Fourth Annual Show, Milwaukee Automobile Dealers' Association.  
 Jan. 13-27.....Philadelphia, Annual Show, First and Third Regiment Armories, Philadelphia Automobile Trade Association.  
 Jan. 15-20.....New York City, Madison Square Garden, Twelfth Annual Show, Commercial Division, Automobile Board of Trade.  
 Jan. 15-20.....Toledo, O., Annual Show, Terminal Building, Toledo Automobile Dealers' Association.  
 Jan. 22-27.....Rochester, N. Y., Annual Show, State Armory, Rochester Automobile Dealers' Association.  
 Jan. 22-27.....Detroit, Mich., Wsnye Gardens, Eleventh Annual Show, Detroit Automobile Dealers' Association.  
 Jan. 22-27.....Providence, R. I., Providence State Armory, Rhode Island Licensed Automobile Dealers' Association, Automobile and Accessories Show.  
 Jan. 27-Feb. 10.....Chicago Coliseum, Eleventh Annual Automobile Show under the auspices of the National Association of Automobile Manufacturers. Pleasure cars, first week. Commercial vehicles, second week.  
 Jan. 27-Feb. 10.....Pittsburgh, Pa., Sixth Annual Show, Automobile Dealers' Association of Pittsburgh, Inc. Pleasure cars, first week. Commercial vehicles, second week.  
 Jan. 29-Feb. 3.....Scranton, Pa., 13th Regiment Armory, Second Annual Show.  
 Feb. 1-7.....Washington, D. C., Annual Show, Convention Hall.  
 Feb. 3-10.....Montreal, Canada, National Show, Drill Hall, Automobile Club of Canada.  
 Feb. 5-17.....St. Louis, Mo., Coliseum, Annual Show, Pleasure cars, first week. Commercial vehicles, second week.  
 Feb. 12-17.....Ottawa, Ont., Howick Hall, Annual Show, Ottawa Valley Motor Car Association.

Feb. 12-17.....Kansas City, Mo., Annual Show, Combined Association of Motor Car Dealers.  
 Feb. 14-17.....Grand Rapids, Mich., Third Annual Show.  
 Feb. 17-24.....Pittsburgh, Pa., Second Annual Show, Exposition Bldg., Pittsburgh Auto Show Association, Inc.  
 Feb. 17-24.....Newark, N. J., Fifth Annual Automobile Show, New Jersey Automobile Exhibition Company, First Regiment Armory.  
 Feb. 17-24.....Minneapolis, Minn., National Guard Armory and Coliseum, Annual Automobile Show, Minneapolis Automobile Show Association.  
 Feb. 19-24.....Omaha, Neb., Seventh Annual Show, Auditorium, Omaha Automobile Show Association.  
 Feb. 19-24.....Hartford, Conn., Annual Show, Automobile Club of Hartford, State Armory.  
 Feb. 20-24.....Binghamton, N. Y., State Armory, Third Annual Show, Automobile Dealers' Association.  
 Feb. 20-28.....Baltimore, Md., Annual Show, Baltimore Automobile Dealers' Association.  
 Feb. 21-28.....Toronto, Ont., Annual Show, Toronto Automobile Trade Association.  
 Week Feb. 22.....Cincinnati, O., Annual Show, Cincinnati Automobile Dealers' Association.  
 Feb. 24-March 2...Brooklyn, N. Y., Twenty-third Regiment Armory, Annual Show, Brooklyn Motor Vehicle Dealers' Association.  
 Feb. 26-Mar. 2.....Elmira, N. Y., Second Annual Show, Elmira Automobile Club.  
 Feb. 26-Mar. 2.....Paterson, N. J., Annual Show, Fifth Regt. Armory, Paterson Automobile Trade Association.  
 Feb. 28-Mar. 2.....Davenport, Iowa, Annual Show, Davenport Automobile Association.  
 March 2-9.....Boston, Mass., Tenth Annual Show, Boston Automobile Dealers' Association, Inc.  
 March 4-9.....Denver, Col., Auditorium, Annual Show.  
 March 4-9.....Denver, Col., Annual Show, Auditorium, Motor Field.  
**Meetings, Etc.**  
 Dec. 20.....New York City, Waldorf-Astoria, Annual Banquet of the Automobile Club of America.  
 Jan. 18-20.....New York City, Annual Meeting of the Society of Automobile Engineers.  
**Race Meets, Hill-Climbs, Etc.**  
 Dec. 25-26.....Los Angeles, Cal., Track Races, Motordome.

# THE AUTOMOBILE

Vol. XXV

Thursday, December 7, 1911

No. 23

## THE CLASS JOURNAL COMPANY

H. M. SWETLAND, President

CONDE NAST, Vice-President and General Manager

E. M. COREY, Secretary and Treasurer

231-241 West 39th Street, New York City

Cable Address - - - - - Autoland, New York  
 Long Distance Telephone - - - - - 2046 Bryant, New York

### SUBSCRIPTION RATES

United States and Mexico - - - - - One Year, \$3.00  
 Other Countries in Postal Union, including Canada - - - - - One Year, 5.00  
 To Subscribers—Do not send money by ordinary mail. Remit by Draft,  
 Post-Office or Express Money Order, or Register your letter.

Entered at New York, N. Y., as second-class matter.

The Automobile is a consolidation of The Automobile (monthly) and the Motor Review (weekly), May, 1902, Dealer and Repairman (monthly), October, 1903, and the Automobile Magazine (monthly), July, 1907.

## Nobody Hurt

ONE of the best features connected with the running of the grand prize, the Vanderbilt, the Savannah and the Tiedeman races last week at Savannah was the fact that nobody was bodily injured during the actual running of these races. This pleased every spectator around the circuit. There may have been those who went to the races with the hope of seeing a car upset at a curve or run through a fence, but they went home better pleased at seeing everything go off well. This fact was commented on in every quarter after the completion of the races. True, there were a couple of serious accidents during practice, one of which resulted fatally and the other in the serious injury to one or two persons and in the damaging of several cars. That accident in which a driver was killed was not due to the course or to anybody on the course. It appears that the car was going too fast out of a double turn and could not be held on the road. The other accident was due to touring cars on the course during practice.

The question was asked several times at Savannah how it was that no one was injured out of the forty-six starters in four different races. There are several explanations: In the first place the drivers with fast cars were nearly all, in fact, all seasoned drivers, drivers who know automatically when a left or right rear tire explodes, which one it is without having to turn round and look or have the mechanic look, and drivers who know automatically and instantly what to do in case of tire trouble. These are the two great reasons why Savannah was free from accidents. There were plenty of tire explosions—they took place on every lap. Some of the drivers averaged a tire change every other lap for the twenty-four circuits of the grand prize race and yet they were not once in the ditch. The only answer was that they were seasoned drivers. At nearly all of the other big races this year there have been a number of names comparatively new in road racing and an analysis will show that in the majority of cases the accidents have happened to these novices. In the majority of

cases the accidents have been due to tire explosions. Because of this fact it appears to be more imperative that the drivers before being granted a license to drive in a track race, a road race, a beach race or a hill-climb, be subjected to a tire explosion test. They should be compelled to drive on a broad straightaway and have one of the rear tires exploded at high speeds in order to ascertain, first, if the driver can tell by the movements of his car which tire has exploded and also, if he can properly control his machine. The distance that his car swerves to the right or left should be measured and if it exceeds one-half the width of a road, as used for road races, an accident would likely result and the driver should be refused a racing license.

After a series of big races is the proper time to learn the lessons that are, or should be, enforced at succeeding races. The only accident that resulted fatally at the Savannah races took place during the first day of practice. The driver was taking the turns too fast before he was familiar with them. This suggests that every precaution should be taken on the first day or so of practice. That perhaps only half of the cars should be allowed on the course at once and that each driver should be cautioned against fast driving. Much of the fast driving in early practice is done for advertising purposes. The driver wants to get a little credit in practice; he may think that he will not have much chance in the race. Often the team manager is very close to the ears of some newspaper reporter and wants to get it all over the land that his car has made such-and-such time in practice. There is always a reason. Quite often the time for practice is short and the driver really has to try out his different speed ratios in order to study how to take the turns.

The Savannah Automobile Club, the citizens of Savannah and the soldiers deserve hearty congratulations on the conduct of the races. The course was kept clear from start to finish and the public was well safeguarded by safety fences, by keeping them back from the turns and by guarding all of the dangerous places on the course. The soldiers again demonstrated the fact that they are equal to any emergency, and with such a corps of soldiers it would be possible to keep a course equally clear in the heart of Long Island or in Westchester county, New York. Keeping road race courses clear is simply a matter of purpose. When the purpose is there the rest is easy. It means getting the troops on the ground early and taking possession before the crowds get there. In guarding a course an ounce of prevention accomplishes more than a ton of cure. It would take a big army to clear a course after the mob had positioned its cars all over on it and after the masses had taken up positions that they would have to leave.

The recent series of Savannah races further demonstrated the fact that a 17.14-mile course is too long and that a 10-mile one would be much more preferable, particularly with small fields of cars, such as at present, when not over sixteen compete in one race. At Savannah there were frequently 3- and 4-minute waits and during these the interest of the crowd waned, and as some expressed it, "They forgot that there was a race on." The 10-mile course with a wider roadway is better for holding the interest of an audience than a longer course, particularly during the last half of a race.



# Harmony Reigns at A. A. A. Meeting

**G**REATEST in size and importance of any of the annual meetings of the American Automobile Association is the one held Tuesday at the Astor in New York City. Almost 100 delegates responded to their names at the preliminary roll call and practically all the clubs identified with the national organization were represented either by an officer or by proxy. There had been rumors of dissensions that were scheduled to break out during the meeting but aside from one ineffectual flare the proceedings moved along with harmony and precision.

Vice-president Bonifield, backed by a numerous Ohio delegation and with some scattering support from other states, was supposed to be the leader of the opposition, but when it came to actual proceedings the trouble did not materialize.

The contention was that a resolution introduced at the last meeting by Dr. Bonifield and adopted by the association provided for holding the next annual meeting in the Middle West. Such an entry was not found upon the minutes and Dr. Bonifield and his supporters prepared to have the minutes changed to show such action. The proposed changes were defeated by a vote of 4 to 1 and Dr. Bonifield was given permission to file two affidavits tending to support his contention that such a motion had been made at the last meeting.

When the delegates finally came together on a friendly footing it was explained that the resolution introduced by Dr. Bonifield last year had been held up pending an opinion as to the legality of the plan to hold the annual meeting of the association outside of New York. This opinion was adverse under the existing condition of the association's charter. A change in the charter was thereupon advised, placing the power to fix meeting places anywhere in the country in the province of the Executive Committee.

The meeting then heard the reading of reports covering its work during the past year. President Hooper covered the whole field generally in his report and was followed by Chairman Terry of the Legislative Board who recounted the work of getting good laws upon the statute books and preventing bad ones from being enacted. He dwelt upon the influence of the association in standardizing state laws to their present status and spoke at some length as to the chances of federal legislation. He declared that the federal registration bill only needed one more determined effort to place it upon the book of national laws. He emphasized the necessity for such a law, even with the contingency of general reciprocity.

Chairman Diehl of the Good Roads Board outlined briefly the activities of his committee, paying particular attention to the assistance that had been given the work by the National Association of Automobile Manufacturers. He subscribed to the report of Chairman Terry with respect to Federal registration and applied it to the cause of federal aid in road building.

Chairman Longstreth of the Touring Board told of the extensive map work that had been done under his direction and Chairman Schimpf of the Contest Board presented a summary of the contest work of the year. Among the figures given out by Mr. Schimpf were the receipt of over \$10,000 for sanction fees; \$1,000 for driving licenses; \$7,000 for stock car certificates and the expenditures of his department. His report showed a balance on hand of \$57.

Powell Evans also made an interesting report on international relations in which he discountenanced further attempts to make foreign maps for use in touring abroad. He called attention to the fact that the Michelin Tire Co. distributed free many thousands of interesting maps and road directions for use in foreign countries and warned the assembly that unless the A. A. A. did something toward getting out books on American roads

for use of foreign tourists, the tire concern would certainly forestall the association in that field also.

Horace A. Bonnell, treasurer of A. A. A., presented the last of the general reports when he read the balance sheet covering the finances of the year. According to Mr. Bonnell's report, the receipts for the year were about \$35,000 and that sum together with \$9,000 on hand, at the beginning of the period, constituted the treasury of the A. A. A. Against this sum there were expenditures of about \$41,000, leaving a balance in the treasury of about \$3,000.

The expenditures covered salaries, the largest item; expenses of various sorts and subscription to the *American Motorist* of \$6,700. The receipts showed a subscription of \$5,000 by the N. A. A. M. and the payment of Contest Board bills by the M. C. A. amounting to about \$2,800.

In the afternoon there were a number of addresses and discussions detailing the work shown in the annual reports. Tuesday night the association enjoyed its annual banquet, the largest and best attended function of its kind in the history of the association.

The following officers were nominated and elected: Robert P. Hooper, Pennsylvania, president; Frank M. Joyce, Minnesota, first vice-president; Laurens Enos, New York, second vice-president; C. L. Bonifield, Ohio, third vice-president; Ralph W. Smith, Colorado, fourth vice-president; F. L. Baker, California, fifth vice-president; A. G. Batchelder, New York, chairman executive committee; H. A. Bonnell, New Jersey, treasurer; John N. Brooks, Connecticut, secretary. Executive committee: L. R. Speare, F. G. Staples, Frank G. Webb, H. L. Vail, P. J. Walker, H. E. Coffin, Frank M. Joyce, J. G. Weeks, E. C. Smith, A. H. Knoll, J. H. Edwards, Dr. A. P. Overgaard, H. J. Clark, G. M. Robinson, John A. Wilson, David Beecroft, John N. Brooks, Powell Evans, P. M. Milner, J. P. Coghlin, Paul C. Wolff, James T. Drought, S. A. Miles, F. C. Battey, Charles E. Doe, Edwin S. George, H. A. Bonnell, H. C. Peck, H. B. Race, W. E. Moyer, H. M. Rowe, S. D. Capen, H. L. Gordon, W. M. Stevenson, Oliver Quayle, W. E. Metzger, C. H. Verschöyle and Preston Belvin.

Chairmen of boards: C. T. Terry, legislative; George C. Diehl, good roads; Howard Longstreth, touring information, and William Schimpf, contest board.

The annual banquet was presided over by President Hooper as toastmaster. Among the speakers were: L. R. Speare, C. T. Terry, C. P. Chase, H. L. Vail, Alfred Reeves, A. L. Pope and A. G. Batchelder.

The association will meet probably at some point in the Middle West at its next convention. In the report of President Hooper a further amendment of the constitution was recommended empowering the executive committee to name the place, but it is doubtful whether the constitution of the association can be amended in time to allow that clause to become effective this year. The recent amendment allows the meetings to be held in cities outside of New York at the will of the association.

The whole convention was most harmonious and the get-together spirit was apparent in every move that was made. After the little storm cloud that threatened the opening of the convention had been dissipated, the program was carried out with much speed and accuracy. The general opinion that prevailed among the delegates was most optimistic as to the future of the association.

Owing to the fact that the routine matters of the association were completed with celerity, it was found to be unnecessary to hold any sessions after Tuesday night and consequently the subsequent meetings scheduled were declared off.



Members of the Society of Automobile Engineers Visiting the Panhard-Levassor Factory in Paris

## S. A. E. on French Factory Visit

PARIS, Nov. 28—Scattered somewhat at the close of the English trip, the members of the Society of Automobile Engineers rallied in Paris, and, reinforced by some of the officials of the British Institution of Automobile Engineers, entered the Panhard-Levassor factory in an imposing group. This visit doubtless united a greater number of members than any previous one, and in view of the large amount of sight-seeing done during the previous week, and the many and varied outside attractions of Paris, spoke well for the enthusiasm of the members in following up the primary object of the trip.

Although there was not the same intimate relationship between the heads of the factory and the visitors as on some of the English visits, the directors evidently preferring to keep in the background rather than face the language difficulty, the Panhard-Levassor Company threw open every department of the factory and placed competent guides at the disposition of the visitors. The interest taken in this pioneer French factory was manifest in the difficulty in getting the members through the various departments; the megaphone man had to be very much on the job. With a staff of 2,300 men, the Panhard-Levassor Company produce a car a man per year; more of the car, however, is built by the factory than is usual in French concerns, the Panhard-Levassor Company making all its own castings with the exception of aluminum die casting, building its own wheels, and making most of the accessories except the magneto.

Knight motors were much in evidence, the sleeve valve engine now being employed on 50 per cent. of the chassis produced in this factory. As the total output includes a number of trucks, the Knight is in a considerable majority on the touring car chassis. Wood working machinery was the original business of the Panhard-Levassor Company, and although this has been considerably outgrown by the automobile work, it is still an important section. It is in consequence of the production of wood working machinery that the firm builds all its own wheels, contrary to the general practice in France. Hickory being difficult to obtain in Europe, acacia wood is employed for the spokes, ash generally being used for the rims. The wire wheel has only just been received into favor at this factory, and although it will be fitted on request, is not made a standard feature.

The efforts made by this company to assure a good supply of skilled labor were noted with interest. Owing to compulsory military service robbing every man of 2 years of his life, it is difficult to get youths to go through the usual period of apprenticeship. In consequence a special apprenticeship workshop is maintained, where, under the instruction of skilled mechanics, youths are put through a 3-years' course in practical and theoretical mechanics. During the 3 years nominal wages are earned, and on the completion of the term the youths pass into the main factory, eventually becoming shop foremen and draughtsmen, in the majority of cases. This system has the advantage under the factory laws of allowing the shops to work overtime and night shifts. Where youths and women are present, overtime is not legally allowed.

While the main party visited the Panhard-Levassor works, a small group of members went through the Bayard-Clement factory. These works more closely approach the American standard of organization and operation than any other in France, for they were completely built at one period, not having grown up from year to year, and are fitted with a large amount of American and other automatic machinery. More than any other, Clement has attempted to reduce the cost of production by reason of economic factory organization, automatic machinery, and a reduction in the number of models. A feature is made of completely equipped cars, the body work being done on the premises, only the specially high-class work being done outside. The Clement-Bayard Company possesses its own foundries and a supplementary factory at Mezières, in the French Ardennes, and it is there that all the castings are done and a certain amount of machining carried out; this has the natural tendency to make the Paris factory more in the nature of an erecting shop.

This firm is unique in being the only one to devote itself to the production of aeroplanes and airships. Working at first in conjunction with a balloon maker, the company has gradually extended the scope of its work until the complete airship is now built on the premises. The nacelle is an all-metal construction that can readily be undertaken in an automobile factory: the motors used in airships are mostly of the four-cylinder vertical type, with a cylinder bore of from 6 to 7 inches, and the fitting

has much in common with the automobile practice now in vogue.

Recently a section of the factory has been set aside for the construction of gas bags thus making the firm entirely independent of outside assistance. After being assembled and tested, the practice is to dismount the airships and transport them to the aerodrome at Compiègne, about 40 miles away, where assembly takes place and the trial flights are carried out. This aerodrome is without doubt the finest in the world, the balloon sheds being magnificent structures of steel and galvanized iron with cork lining, having special heating arrangements, electric light, wireless telegraphy installation, special workshops, and a large hydrogen producing plant.

While the main party occupied the afternoon of the first day's visit to Paris in inspecting the Lemoine factory, devoted to the production of axles and automobile springs, a smaller group was received at the Renault works, the largest in Europe devoted exclusively to automobile production and having an annual output of 6,500 cars. Very extensive additions are being made at the present moment to the Renault factory with a view to extensions in the truck line, and in order to enable the firm to make its own aluminum castings. At present all cylinder castings are made on the premises. At the close of the visit to the factory the members of the party spent an interesting half hour in conversation with Louis Renault, recognized as one of the most skilled engineers in Europe. Conversation naturally turned to the American invasion.

Louis Renault regretted that conditions were such in Europe that no manufacturer was able to devote himself exclusively to one or two models. In order to meet all requirements his factory was obliged to produce twenty different types; the European demand was not sufficiently great to allow any manufacturer to devote himself exclusively to one model.

He expressed it as his opinion that the less expensive grades of American cars would not get a permanent hold of the European market, but if they should do so he was convinced that the French government would remove the anomaly of a 25 per cent. duty on American imports into France, and a 50 per cent. duty on French cars going into the United States. For trucks carrying 2, 3 and 5 ton loads, Louis Renault gave it as his opinion that the use of rubber tires would have to be abandoned on account of cost. This was particularly the case in France where they had to compete with horse traction and cheap labor. The price paid for carrying a ton load anywhere within a 7-mile radius of the city of Paris was only 60 cents on horse-drawn vehicles, and in order to get down to this low figure with automobiles, it was necessary that tire maintenance should be abolished entirely. Renault has made a move in this direction by building 3 and 5 ton trucks fitted with steel tires, and is so convinced of their greater economy, that he recommends them in preference to rubber shod trucks.

To give an insight into the development of the aeroplane industry in France, a visit of inspection was paid to the Esnault-Pelterie factory at Billancourt, where Rep monoplanes and motors are built. The firm is occupied almost exclusively on military work, and produces an all-metal monoplane of unusual strength. Steel tubing is employed throughout for the fuselage of the machines, the entire front portion being encased with sheet aluminum, and the rear covered with rubbered cloth. The wings are the only portion of the aeroplane in which wood is employed. All the motors are built on the premises; they are five-cylinder type, air cooled, with valves in the head operated by a single overhead rocker arm. Three connecting rods are received on one pin of the two-throw crankshaft, and two on the other; the shaft is bored and has forced feed lubrication. An interesting mechanical construction was the fitting of the carbureter in the oil sump of the crankchamber in order to assure an even temperature in all weather conditions. The float chamber was outside and at the base of the motor, with the jet within the base and the intake pipe running right across the oil tank, then passing outside to a circular distributor from which the five cylinders were fed. The original intention was to pay a visit to the Rep aerodrome

at Buc, but as weather conditions made flights impossible, this visit was abandoned.

Louis Delage, one of the leading French light car manufacturers threw open his works to the American engineers, and a number of the members of the party availed themselves of the opportunity of inspecting them. This factory is one of comparatively recent origin, having been established 5 years ago with the object of building what is known as voiturettes. Single cylinder models only were produced at the commencement, but these were later driven out by four-cylinder cars, and the output now consists of two models only, a four-cylinder of 75 by 120, and a six-cylinder of 65 by 125 mm. bore and stroke; the present output is 1,000 cars per year. Delage was the winner of the last light car race held during the past season in France, under the 3 litre cylinder volume rule.

As a fitting close to the European trip, André Michelin entertained the members of the Society of Automobile Engineers with a dinner at the Automobile Club of France on the last day of the official visit. André Michelin, in rising to propose the toast of the President of the Sister Republic, stated that he knew 24 English words, and as seven of them were not fit to print, he believed it would not be possible to make a speech with the remaining 17. He, therefore, asked them to allow him to greet them in his own language, leaving it to his brother-in-law, Mark Wolff, to translate that greeting into English. In drinking to the success of the American automobile industry, Mark Wolff, director of the Michelin Tire Company, of London, hoped to see more and more American automobilists in Europe, and assured them that they would always find the touring organization of the Michelin company at their disposition.

Mr. Havvette-Michelin, manager of the Michelin factory at Milltown, N. J., thanked the Society of Automobile Engineers for the honor they had done them in accepting their invitation and expressed the belief that such gatherings would do much to strengthen the bonds which united the industries of America to France.

Howard E. Coffin replied in the name of the American engineers and retraced the growth of the Michelin company from the earliest days to the present time with its establishments in four countries and its staff of 15,000 workers. The evening closed with a concert given by some of the most brilliant artists of the opera and the Opera-Comique, and by a set of dances performed by Mlles. Chasles and Meunier of the Paris Opera house.

Although the official program of visits in France was not as elaborate as that drawn up for England, small groups and individual members of the party visited numerous other factories. A small number, too, extended their investigations to Germany.

### Revival of Paris Annual Show

Finding the center of the European automobile market slipping away from Paris, in favor of London, Berlin and Brussels, the French Association of Automobile Manufacturers, presided over by Marquis de Dion, is determined that the annual automobile salon at the Grand Palais in Paris shall be revived and that the income from it shall be distributed among the exhibitors, so as to reduce the cost of staging the great show, rather than turning the profits into the treasury of the Automobile Club de France, whose leading men, René de Knyff and Louis Renault, "under the placid presidency of Armand Peugeot," are charged with the responsibility for having weakened the position of the French industry by first rendering the cost of the annual show prohibitive, for the benefit of the club, and afterward abolishing it; all for the selfish motive of preventing small and progressive manufacturers from making themselves conspicuous before the public and establishing a competition with the big and prosperous concerns which the leaders in the club represent. "The fight between the two factions is on, and soon the columns of the automobile press will reverberate with the echoes of the battle," says *L'Automobile Belge*, November 10.



Starting from Savannah in the tour around Georgia



Bell's Ferry across the Altamaha Ferry, outside of Toxley, Ga.

## Georgia Tour Proves Hard Ride

ATLANTA, GA., Dec. 4—Slightly the worse for chilling breezes and dusty roads, but not otherwise disfigured, the Tour Around Georgia rolled smoothly into Atlanta Saturday afternoon and completed the second annual run around the Empire State of the South.

This tour left Atlanta, for an eleven-day trip on the morning of Wednesday, Nov. 22. It arrived at Savannah Saturday afternoon, Nov. 25. All of the tourists spent Sunday in Savannah and Monday at the race course, watching the running of the Vanderbilt. Then five cars, with W. B. Stovall, of Atlanta, acting as pacemaker in his Cole 30, checked out Monday morning at 8.30 and continued on a sort of informal jaunt to Atlanta. Those in this party included No. 57, Cole 30, W. B. Stovall, acting pacemaker; No. 40, Chalmers, Sheriff F. G. Edwards, of Dougherty County; No. 30, Buick, C. A. Holmes; No. 28, Cadillac, C. A. Fuller; No. 32, Buick, C. A. Thatcher.

These cars got away in the midst of a most depressing rain but once out of Savannah they met better roads and from that point forward found reasonably good going. Their trip to Atlanta was without special incident and they checked out, after a two-day run Wednesday night, Nov. 29.

The main body of the tourists waited for the running of the Grand Prize race, on Thanksgiving Day, and did not desert the scene of action until the very last gun had been fired.

This main body checked out of Savannah Friday morning, Dec. 1, with the coldest weather of the coldest early winter Georgia has ever known, making things generally unpleasant. Nor was the road from Savannah to Dublin, the night stop, any material improvement over the weather. It was frosty and bumpy going most of the day, with just enough warmth toward noon and just enough good going by spells to keep up the courage of the contestants.

Friday's run saw another perfect score go by the board, which was remarkable in a tour run on such liberal lines as the Tour Around Georgia. Overland 28 was the victim and in a collision with another competitor, also an Overland, its radiator was so badly injured that the car was put temporarily out of commission. A Dorris car, driven by George Fauss, towed the victim to Summit, where a repair was made.

The middle of the day proved the pleasantest part, for the weather improved materially and what with good roads into Statesboro, and a good lunch there at the Jaeckel House the tourists thawed out and cheered up materially.

The afternoon run was a mere matter of plugging along and

all the cars, save the injured Overland, hauled into Dublin, the night stop, in good order. This town of Dublin was one of the cities most active in promoting the tour. The citizens want the Dublin route between Atlanta and Savannah accepted as official and in consequence were intensely interested in the present tour. This interest was shown Friday night by a tremendous ringing of bells and an amazing blowing of horns and playing of bands. At no place on the tour was the welcome any more sincere or enthusiastic than at Dublin. The day's run was 124.8 miles. The lunch stop was 50.7 miles from Savannah.

The last day's run of the Tour Around Georgia, was 152 miles in length and carried the tourists from Dublin to Atlanta over roads that were in the main good, and under skies that were fair enough.

The last section of the run, from Macon to Atlanta, was especially fine. This strip of road is one of the finest 100-mile straightaways in all Dixie and the tour cars fairly burned it up.

When the Round-Staters reached Atlanta they went at once to the Piedmont Driving Club, where they were checked out and where a beefsteak dinner was served. At this meal the tourists were the guests of the Atlanta Constitution, which has done much toward promoting and engineering the trip.

Owing to the intense informality of the run it may be several days before announcements are made as to the penalizations but it is probable that only three of the cars that participated will receive penalties.

The only prize thus far awarded was to the Overland No. 28, which was voted the trophy offered by the Atlanta Ad-Men's Club for the machine that met with the hardest luck while on the road. The Overland was the hard-luck car of the tour.

The tour just completed was probably the most successful state tour ever run in the South. It was the verdict of the few who took part both in this event and in the recent Glidden that the Georgia event was the harder of the two on the contestants. While the running time was slower and the rules less vigorously enforced the roughness of many of the strips of road and the roughness of the weather combined to make the affair decidedly rigorous.

It is worth noting, however, that the roads encountered on this year's tour were better than those traversed by the same tour last year, that there were more bridges and less fords and that the people in the counties where bad roads still exist were thoroughly awake to the need of better roads and were planning to get them.

## In the Legal Field—Weed Chain Wins

ACCORDING to information received by Duncan & Duncan, of New York, attorneys for the Weed Chain Tire Grip Co., from Washington, the Supreme Court has denied the petition of the Excelsior Supply Co., of Chicago, for a writ of certiorari to review the decision of the United States Circuit Court which held in favor of the legality of the Parsons patents which are owned by the Weed company. The refusal of the Supreme Court to further consider this case is the final step in a long litigation. At present there are pending in New York and elsewhere over 175 cases brought by the Weed company, in all of which preliminary injunctions have been granted.

The United States Court of Appeals has issued interlocutory decrees against a number of defendants, based upon the Weed patents. Several of these suits are now pending before masters who have been instructed to determine the amount of damages involved.

### Rubber Contract in Federal Court

Before the United States Circuit Court of Appeals in New York the final hearing of the suit of Henry A. Gould against the Pennsylvania Rubber Co. was held Monday and the decision is now being considered by the court. The Pennsylvania Rubber Co. sued Gould in the lower court to recover \$16,592 for alleged failure to deliver to it 16,592 pounds of Manicoba rubber which was contracted for in June, 1909.

The defendant claimed that he had delivered 9,253 pounds of the contract amount and that the plaintiff company refused delivery tendered upon the remainder. A jury in Judge Hough's court awarded the Pennsylvania Rubber Co. \$11,713 as damages and from this judgment Gould appealed. Gould imports rubber and the Pennsylvania company manufactures rubber goods.

The issue between the two is as to the quality of the rubber delivered. On the part of the company it is alleged that the rubber was rejected because it would not vulcanize evenly and the Gould concern declares that there was nothing in the contract to specifically provide for even vulcanization.

### How Old Acme Company Almost Won

How the old Acme Motor Car Company almost got another lease on life back in 1906 was told in the New York Supreme Court last week, when the cases of Pirie versus Emery, Somers and Curran were decided in favor of the plaintiff. It appears that the automobile company actually had possession of enough money to tide it over the rough spot it was encountering but that an effort was made to stop payment upon two checks, aggregating \$65,000, and while the stop was not permanently effective it resulted in a swarm of creditors swooping down upon the company at an inconvenient moment, causing its bankruptcy.

The story as told in court was one of intense human interest. Mr. Devlin, who was in charge of the Acme company at that time, was being pressed for payment of \$55,000 due to a Mr. Horst on the purchase of the company's control. The company was also short of ready cash. Therefore, he arranged with the plaintiff Pirie for a loan of \$65,000. The defendants Emery, Somers and Curran gave Pirie their notes and checks for a total of \$40,000 and Pirie advanced two checks, one for \$55,000, which was paid over to Horst and the other for \$10,000 which Devlin deposited to the order of the company.

The next day after this was done, January 24, 1906, Pirie decided not to carry out the transaction and notified the defendants that he was going to try to get out and advised them to do

likewise. Payment was stopped on the two Pirie checks and identical notes were written by the defendants disclaiming liability on the notes they had given.

But in the meantime the attorney for Pirie informed him that payment on the checks could not be stopped and after some delay the order of stoppage was released. It was too late for the Acme company, however, for the checks of Devlin that had been returned unpaid by his bank caused the creditors to descend upon the company, eventually throwing it into bankruptcy.

Then the defendants declined to pay their notes to Pirie and suit was brought against them in the Supreme Court. These were heard by Justice Blanchard, who decided that defendants were liable to Pirie for the amount of their notes with interest.

### Auto Lighter Co. Asks for Injunction

COLUMBUS, O., Dec. 7—Alleging infringement of patent rights, the Auto Lighter and Equipment Company, of Boston, has asked the United States court to enjoin further sales of a device for automatic gas ignition manufactured by the Inst Lighter Company, of Columbus. F. C. Barger and Byron L. Barger are president and secretary of the local company, which has an office at 55 1-2 East Main street.

### Daimler Levies Upon French Firms' Exhibits

In consequence of certain claims for violation of its patents and difficulties in obtaining judicial satisfaction for these claims in French courts, the Daimler Motoren Company of Stuttgart-Untertuerkheim at the conclusion of the recent automobile show in Berlin had the sheriff levy upon and take possession of the exhibits of the French firms Clement-Bayard, Mors and La Buire, subject to release against bonds.

### Madero to Urge Good Roads in Mexico

MEXICO CITY, Dec. 1—Automobilists and others in Mexico are greatly interested in the announcement by President Francisco I. Madero, Jr., that one of his policies will be to promote the construction of good roads throughout the republic. There are already several splendid highways in the federal district.

The favorite highway for automobile pleasure seekers of the capital is that which runs between this city and Toluca. The distance is 45 miles, and the route lies through grand scenery.



Automobile highway between Mexico City and Toluca



## Late Racing and General News

INDIANAPOLIS, IND., Dec. 4—The annual motor car hill climb of the Evansville Automobile Club, was held at Evansville Thanksgiving Day, a large crowd of spectators witnessing the contest. The Evansville *Courier* offered a silver trophy to the winner of the free-for-all class. While the best time in this class was made by Charles French, driving a Cole, a protest against French receiving the award has been filed with the judges by Armand Emrich, who drove a Marquette-Buick, on the ground that French is a factory driver and a professional. A summary follows:

Free-for-all: Cole, driven by Charles French, first; Marquette-Buick, driven by Armand Emrich, second; time, 48½ seconds.

Cars with 4½-inch bore: Cole, driven by Charles French, first; Knox, driven by Morton Mannheimer, second; American, driven by Elmer Lehnhard, third; time 48¾ seconds.

Cars with 4¼-inch bore: Chalmers "36," driven by G. C. Keck, first; Maxwell, entered by Echert-Maxwell Co., second; time, 54 seconds.

Cars with 4-inch bore: E-M-F, driven by Fred McNeeley, had no competition; time, 58½ seconds.

Cars of less than 4-inch bore: Ford, entered by Korb and Stewart, first; Cameron, driven by Herbert Laubscher, second; time, 1.01¾.

Cars driven by ladies: Cadillac, driven by Miss Beatrice Curry, first; Cadillac, driven by Miss Eloise Koch, second; time, 58 seconds.

### Savannah Not Anxious for 1912 Grand Prize

SAVANNAH, GA., Dec. 3—Whether Savannah will ever have another Grand Prize or Vanderbilt race is doubtful. Neither the officials of the Savannah Automobile Club nor Mayor Tiedeman would talk upon the subject, otherwise than to say that they thought Savannah had seen its last automobile race for years to come. To add to the feeling of doubt as to the future, the night following the Grand Prize race was allowed to pass without any attempt to secure the event next year.

The railroads entering the city gave out an official statement in which it was set forth that they handled 30,000 strangers as against 17,000 last year.

Starter Wagner before his return to New York outlined a new 10-mile course which should be easily capable of a speed of 80 miles an hour.

Instead of making the "S" turn which leads to Whitfield avenue, the Montgomery Cross Roads could be connected with Norwood avenue. With this new road both Whitfield and Ferguson avenue with the turns at Montgomery Cross Roads will be eliminated.

### Gold Prize for Tour to Dawson

SEATTLE, Nov. 29—Complete rules governing the awarding of a gold trophy for the first automobile touring continuously between Vancouver, B. C., and Dawson (or any other settlement in the Canadian Yukon or Alaska an equal or greater distance north than Dawson), via a continuation of the Pacific highway route, have been issued by the Pacific Highway Association.

This makes the third trophy to be put up by the association for pioneering runs along projected continuations of its route. The first, for the Seattle-Hazelton trip, was won by P. E. Sands; the second, for a tour from San Diego to the city of Mexico, will

probably be contested for next Spring or Summer. All these trophies are similar in appearance, being reproductions in gold of an automobile rear wheel engraved around the side of the tire and with space on the brake drum for the winner's name.

The rules for the Dawson tour, covering 13 clauses, are largely similar to those of the other contests. The thirteenth and fourteenth clauses are of special interest. They provide that the route from Vancouver to Lytton must be nowhere more than 10 miles distant from the Frazer river, and that from the start the run must follow wholly within the confines of British Columbia, Alaska and the Yukon. Pacific highway pennants must be carried and a complete set of photos taken en route. A log also must be kept.

Immense difficulty would attend an attempt for this more than 1,400-mile run at present, but with the recent discovery of enormous coal fields in the Groundhog district, 140 miles north of Hazelton, it seems probable that the British Columbia government will begin a wagon road into that country, along the projected Pacific highway route. This, together with the provincial government's activity in behalf of highways and the recently avowed Federal intention of helping roads in the provinces, encourages the promoters of the Dawson run to believe that it can be undertaken with a considerable chance for success within 1-2 years.

### San Mateo to Have Good Road System

SAN FRANCISCO, Dec. 4—At a recent meeting of the San Francisco Motor Car Dealers' Association the following resolution was adopted:

"San Mateo county, realizing the importance of good roads, and the lack of the same in that county, is coming to the front in the way of bonding itself for \$1,500,000 for the purpose of constructing good roads in that county, commencing at the boundary line of San Francisco county and extending to the extreme south of San Mateo county, with cross roads running from the bay to the ocean side. The county surveyor for some time past has been preparing a survey of these roads, and will soon make his report to the county, when the question will come before the proper officials for the passing of said bond issue. The Coast Side Promotion Association and the San Mateo County Development Association are both doing all in their power to bring about this result and to make a success of the bond issue which will come to vote in a short time.

"There have now been granted in the state of California licenses to the extent of 59,000 automobiles, and automobiles are now being sold in the State of California at about the rate of 60 per day, so that the magnitude of this business can be hardly realized. It is a crying shame that San Francisco, the metropolis of the coast, should have such wretched exits as it has on this side of the bay, and it is unnecessary to tell of the great benefits which would be derived from the bond issue in San Mateo county."

### Maxwell, McNay's Mechanic, Dead

SAVANNAH, GA., Dec. 4—H. F. Maxwell who was riding as mechanic for Jay McNay, who met his death while practicing over the Grand Prize course here on November 20, died on Sunday afternoon at the Savannah Hospital, where he was confined since the accident. Maxwell was from Jacksonville, Fla. His body has been sent there.

## Detroit Items in News of Week

**D**ETROIT, MICH., Dec. 4—The Studebaker Corporation, maker of E-M-F "30" and Flanders "20" motor cars, has inaugurated a radical change in its selling policy that is fraught with a great deal of significance to the industry as a whole. The corporation has decided to sell motor cars on credit and hereafter will accept notes from farmers and other responsible buyers. In explanation of this innovation, Walter E. Flanders, general manager of the Detroit factories of the factories of the Studebaker Corporation, says.

"I believe the motor car business should be placed on a credit basis, and I believe the action we have taken will lead to the most important advance that has been made in the industry since its inception. It indicates that the motor car has now arrived at the stage where it is no longer a high-priced luxury, but has actually become a necessity in the lives of all business men and other well-to-do people. First the motor car business was called a 'game'; now it has attained the dignity of an industry. The motor car itself was originally a play toy, then an expensive luxury for the rich; now it is a staple, a necessity, and as such it should be sold as all other staple articles."

The Studebaker Corporation's action has been the subject of a good deal of discussion among local makers, but whether the example will be followed by others as a fixed policy remains to be seen. That the time is coming when motor cars will be sold as are other staple commodities, to responsible buyers, by the manufacturers generally, is regarded as certain, but there seems to be a doubt in some quarters as to whether the time is ripe for the inauguration of such a policy.

Important changes in the administrative forces of the Lozier Motor Co. are announced. Owing to the rapid growth of the business, it has been found necessary to further divide the responsibility, and in this connection the position of general manager has been created. Fred C. Chandler, second vice-president of the company in charge of sales, who has been associated with the Loziers for the past 21 years, has been advanced to this position. John G. Perrin, who has been identified with the Loziers in various capacities for the past 17 years, has been appointed vice-president and chief engineer. Charles A. Emise, formerly in charge of the advertising department, succeeds Mr. Chandler as sales manager, and Russell E. Benner becomes production manager.

Rapid progress is being made on the new plants and additions under way in this vicinity. At the Ford plant the finishing touches are being put on the mammoth addition and a part of the extra space is already being utilized. The Hupp Motor Car Co. expects to have its new Windsor branch factory in operation by January 1. It will have a capacity of 2,000 cars per year. The company's new local plant is well under way. The company expects to move into one department this month, and the factory will be completed some time in January, according to present indications. It will have a capacity of 15,000 cars per year. The old plant on Jefferson avenue is turning out cars right along and is not storing any. The Cadillac Motor Car Co. has just let the masonry contract for a new storage building at its plant. The remainder of the work will be done by the company itself.

Knell & Adams, automobile body finishers, have practically closed a deal for the purchase of a two-story factory building at 1039-1043 Jefferson avenue, which will increase the company's facilities 100 per cent. after contemplated alterations are completed. The company is now located at 1020-1030 Beaufait avenue, and this plant will be continued. The newly acquired property was formerly used for an overall factory. It is under-

stood that the purchase price agreed on is in the neighborhood of \$50,000.

That the Mexican government is awakening to the commercial and industrial possibilities of the motor car is evident from the fact that it has just commissioned two of its engineers, Ernesta Silva and Eduardo D. Escobar, to study motor car building in this city. The men have been given positions in the plant of the Hudson Motor Car Co. and will learn the business from the ground up, under the direction of Howard E. Coffin. They began their apprenticeship in the "rough test" department.

The Hudson Co. furnished the motor cars for conveying a party of western governors about the city of Detroit on Thanksgiving day.

George D. Wilson, sales manager for the Warren Motor Car Co., has just returned from an Eastern trip in the interests of the company and says that the outlook for future trade in that section is more promising than it has been in any previous year at this season.

J. B. Eccleston, sales manager for the Oakland Motor Car Co., of Pontiac, has left for an extended trip through the West to visit Oakland dealers and get a line on conditions. He will be gone about a month.

### Everitt Banqueted by Agents

PHILADELPHIA, Dec. 4—B. F. Everitt, president of the Metzger Motor Car Company, manufacturers of the Everitt line of cars, and Wallace C. Hood, sales manager of the factory, were the guests last evening of W. Wayne Davis, who handles the Everitt in this territory, at the newly-remodeled showrooms of the local branch, Nos. 600-602 North Broad street. About fifty all told were present at the housewarming, composed of sub-agents of the Everitt from Pennsylvania, New Jersey and Maryland, and local newspapermen. Speeches outlining the policy of the company were made by Mr. Everitt, Mr. Hood and Mr. Davis. The headquarters of the W. Wayne Davis Company were beautifully decorated and music further added to the enjoyment of the occasion.

### Hoosiers Have Horseless Fire House

INDIANAPOLIS, Dec. 4—After experiments covering more than a year, which have resulted satisfactorily, the Indianapolis board of public safety has announced a policy of replacing the horse-drawn equipment in the fire department with motor-drawn equipment as rapidly as possible. At first such installations are to be largely in the districts having paved streets, although experiments are now about to be made with such equipment in districts where there are some unimproved streets.

Equipment, consisting of a gasoline combination hose and chemical wagon, has been ordered for a new fire engine house being erected in Thirty-eighth street, in a residence district where there are few improved streets. This will be the first engine house in the city having no provision for horses and thus the first step toward motorizing the fire department.

Before February 1, 1912, it is planned to install a motor combination hose and chemical wagon in engine house No. 5 in Fifteenth street and to replace the hose wagon at engine house No. 20 in Beville avenue with motor equipment. It is also planned by that date to install motor equipment in engine house No. 25 in Irvington, in which are now stationed a horse-drawn hose wagon and ladder truck.



Installation of Baker electric commercial cars recently delivered to the United States Government

**WASHINGTON, D. C.**—The Baker Motor Vehicle Company, of Cleveland, O., has recently delivered two delivery wagons, two light trucks and two heavy trucks to the United States Government for the use of the Bureau of Printing and Engraving.

**CASPER, WYO.**—The Shulte Hardware Company has taken the Cadillac agency.

**DENVER, COL.**—The Alkire Motor Car Company has taken the agency for the Thomas flyer.

**KANSAS CITY, KAN.**—The A. J. Davis Motor Car Company has removed to 1710 Grand avenue.

**KANSAS CITY, KAN.**—The Motor Tire & Supply Company has removed to 1708 Grand avenue.

**DENVER, COL.**—The Carstarpen Electric Company has taken the agency for the Flanders electric.

**WICHITA, KAN.**—The Cole Motor Company has moved into new quarters at First and Water streets.

**OMAHA, NEB.**—The Powell Supply Company has taken the agency for Republic tires for this territory.

**OWENSBORO, KY.**—Lee Brothers have sold their garage on St. Ann street to R. G. Jesse and J. M. Miller.

**NEWARK, N. J.**—The Oakland Sales Company has been organized to handle the Oakland car in this vicinity.

**OMAHA, NEB.**—The Moline Automobile Company has opened a branch in this city with D. M. Deal as manager.

**SPOKANE, WASH.**—Harry Bell, a well-known automobile dealer of this city, has added the Mitchell to his line.

**WILKES-BARRE, PA.**—The Deitrick automobile agency of this city has taken the agency for the National 40.

**DENVER, COL.**—G. A. Maxwell and F. Chamberlin have taken the Western distributing agency for the Haynes car.

**DENVER, COL.**—The Esterline car is now represented here by the Western Engineering & Specialty Company of 1732 Glenarm street.

**CHICAGO, ILL.**—E. Ruelbach has joined the sales force of the United Motor Chicago Company. Mr. Ruelbach will sell the Columbia car.

**CLEVELAND, O.**—The V. R. Hall Automobile Company, state distributor for the Cartercar, has opened its new salesroom on Euclid avenue.

**WASHINGTON, D. C.**—A new garage has been opened at 96 West Maiden street by Thomas O'Rorke, who will handle the Overland in this territory.

**BIRMINGHAM, ALA.**—D. J. and W. T. Fox have secured the agency for the Matheson car and have opened a garage at 321 South Twentieth street.

**BINGHAMTON, N. Y.**—The New York Sales Company will handle the Rambler in Broome, Chenango and Tioga counties during the coming year.

**HARLAN, IA.**—The Booth Implement Company of this city has let the contract for the erection of an automobile garage to Alexander Smith of this city.

**CINCINNATI, O.**—The Kruse Motor Company has appointed Scott Socars agent for the Maxwell in Adams county. A sub-agency has also been established at Lexington, Ky.

**WILMINGTON, DEL.**—The Autocar Company, of Admore, Pa., has opened maintenance headquarters at 714 Orange street. J. P. Harvey is in charge.

**OMAHA, NEB.**—The Velie Automobile Company is erecting a new garage at Tenth and Howard streets which will be completed early in December.

**SYRACUSE, N. Y.**—W. King Smith has taken the agency for the Moon car for this vicinity. Mr. Smith also handles the National and Pierce-Arrow.

**SCRANTON, PA.**—The name of the local agent for the Cole car has been changed from the Penn Auto Company to the Scranton Penn Auto Company.

**JOHNSTOWN, N. Y.**—H. S. Bowler has become associated with the St. Charles garage and in the future will have charge of the mechanical department.

**SAN ANTONIO, TEX.**—The United States Tire Company is preparing to open a branch in this city. It will be situated at 433 Main avenue with F. D. Welch as depot manager.

**FORT WORTH, TEX.**—Joseph Radcliffe & Sons have completed the equipment of their new automobile repair shop at Second and Throckmorton streets and it is now in operation.

**SYRACUSE, N. Y.**—T. A. Young, of this city, has taken the agency for Onondaga and Cayuga counties for the R. C. H. car, manufactured by the R. C. Hupp Motor Car Company, of Detroit, Mich.

**MILWAUKEE, WIS.**—The city of Milwaukee oiled exactly 71 miles of streets during 1911, or 50 per cent. more than in 1910. The cost of oiling for 1911 is \$0.402 per foot as against \$0.550 in the previous year.

YOUNGSTOWN, O.—The Motormart has just completed arrangements whereby it secures the dealership in Franklin cars in this territory for the coming season.

CANTON, O.—The A. H. Wilson Motor Car Company, of this city, located at 516 North Cleveland avenue, has taken the 1912 agency for the Cadillac and the Detroit Electric.

KIEL, WIS.—The Motor Car Company of Kiel, incorporated with a capital of \$10,000, will establish a garage and repair shop at once. The concern is negotiating for agency lines.

DENVER, COL.—William Pete has assumed the managership of the Fry & McGill Auto Supply Company of this city, succeeding John Fry, who is now sales manager of the local Everitt branch.

SAN ANTONIO, TEX.—The Taxicab Company has filed an amendment to its charter changing its name to the San Antonio Transfer & Taxicab Company and increasing its capital to \$30,000.

KANSAS CITY, KAN.—The Karshner Motor Car Company is now occupying handsome new quarters at Thirteenth street and Central avenue. The company handles the Warren and Speedwell cars.

WINNIPEG, MAN.—The Tudhope Anderson Company, of this city, Canadian distributor for the Everitt car, has opened branch houses at Brandon, Man.; Swift Current, Sask., and Gorkton, Sask.

KANSAS CITY, KAN.—The Diamond Rubber Company has opened a branch at 1316-18 Grand avenue, in charge of J. F. Lanier, who will also have charge of the branch houses at Omaha and Oklahoma City.

WINNIPEG, MAN.—The Breen Motor Company is occupying its new salesrooms and service station at the corner of Broadway and Sherbrooks street. The company handles the Cole car in this territory.

MILWAUKEE, WIS.—The Smith-Hoppe Auto Company has moved into its new salesroom at 215 Wisconsin street. The company is agent for the R. C. H., Oakland, Oldsmobile and Hupp-Yeats electric.

LANCASTER, PA.—Partnership existing between Herbert R. Bowers and Eugene R. Russell, trading under the firm name of the Conestoga Auto Company, has been dissolved. Mr. Russell retains the business.

RACINE, WIS.—The Racine Automobile & Motor Works, which recently established a new garage and shops on State street, handling the Buick line, are engaged in the production of a new type of motor for pleasure cars.

ATLANTA, GA.—John F. Lakin, special representative of the Studebaker Corporation for the entire Southeast, has just been detailed for this territory. He was for-

merly with the company at Detroit. His headquarters will be in this city.

MISHAWAKA, IND.—The American Castings Company has taken on more employees in its foundry. The company is making castings for automobile concerns in Peru, Goshen, Rockford, Mishawaka and other cities.

DETROIT, MICH.—H. L. Winter has been appointed sales manager for the Federal Truck Company, of this city. Mr. Winter's experience in the automobile business dates from the time when the industry was in its infancy.

ST. LOUIS, MO.—The Banner Rubber Co. of this city has increased its capital stock from \$100,000 to \$400,000 for the purpose of equipping a much larger plant for the manufacture of automobile tires and other rubber goods.

VICTORIA, TEX.—The Texas Motor Car & Supply Company has let the contract to the Bailey Mills Company of this place for the erection of a two-story addition to its machine shops here. Harry Dilley is manager of the plant.

ST. LOUIS, MO.—Curtis Jack & Truck Company, recently incorporated at Jefferson City, Mo., capital \$75,000, will establish a factory here to manufacture a combination hand-truck and jack for handling automobiles in garages.

NEW YORK CITY.—The Henry Manufacturing Company has leased the garage at 141 West Fifty-fifth street. The company will manufacture an automatic device for starting gasoline engines. The initial capitalization is \$100,000.

NEW YORK CITY.—The Motz Tire & Rubber Company, of Akron, O., has opened a branch in this city at Fifty-fifth street and Broadway. E. P. White, formerly connected with the Goodyear Tire & Rubber Company, is in charge.

BOSTON, MASS.—A. H. Sowers, formerly with the Welch Detroit branch in this city, has joined the sales force of the Jackson

agency. Mr. Sowers handled the Jackson in Boston before as a member of the Sowers-Soden Company.

BALTIMORE, MD.—The Goodyear Tire Company is the latest concern to locate in Baltimore's motor-car row. The company is having a residence on Mount Royal avenue near Maryland avenue converted into modern salesrooms.

BOSTON, MASS.—Clifton C. Edwards has been made manager of the local branch of the Marquette Buick in Boston, succeeding George Lighthall. Mr. Lighthall is to represent the company on the road, opening agencies throughout New England.

CINCINNATI, O.—The local agency of the Cadillac has opened branch agencies at Ashland, where the Great Eastern Automobile Company will look after the sale of the car, and at Greenville, Ky., where its interests will be cared for by J. E. Upp.

BALTIMORE, MD.—Another car new to the Baltimore field is the De Tamble, which is being handled by Callahan, Atkinson & Company, Charles street, opposite Pleasant street. Callahan, Atkinson & Company are also the representatives for the Locomobile.

CHICAGO, ILL.—The Velie Motor Vehicle Company has absorbed the Velie Motor Car Company, of this city, and has made it a direct branch. Morton H. Luce, who is in charge of the New England branch, will also act as manager of the Chicago branch.

CLEVELAND, O.—A Boston man has written the White Company, of this city, that he never hunted so comfortably as he now does in his White gasoline truck. He had always used a large touring car until this fall but finds the truck much more satisfactory for hunting purposes.

MISHAWAKA, IND.—The Star Garage is in the hands of a new corporation, the capitalization of which is \$5,000. The officers are as follows: Guy Stutzman, president and superintendent; Louis Slick, secretary and treasurer; Marion Pancake, general manager; Charles Renner, sales manager.

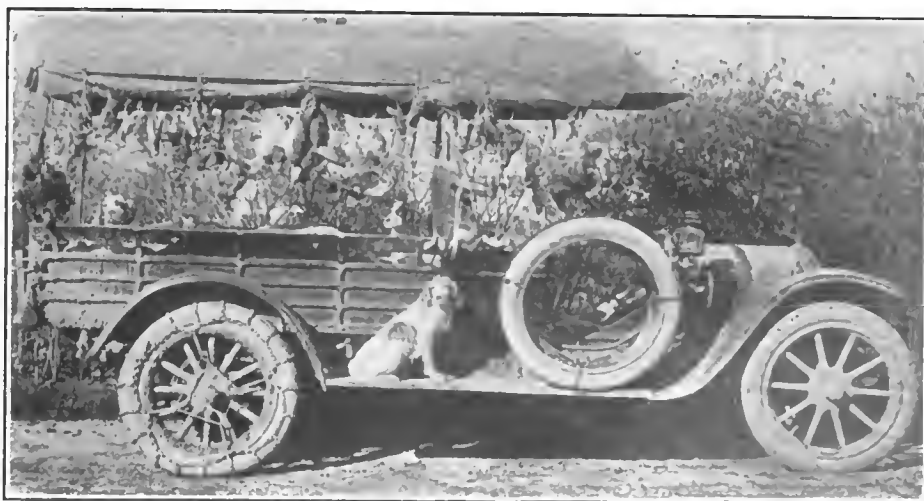

How a Boston man uses a White truck in his hunting expeditions

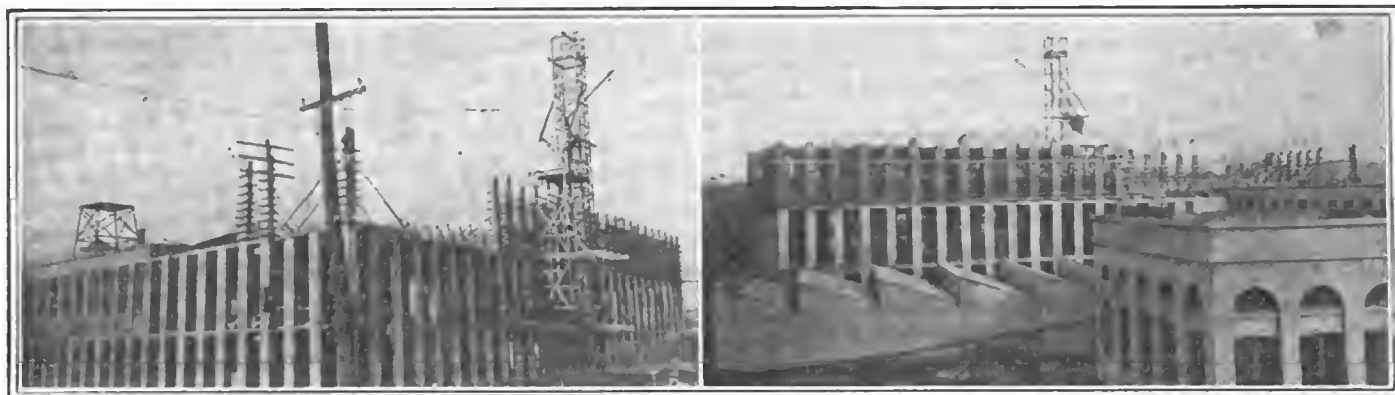

Two views of the new factory now in course of erection for the Rushmore Dynamo Works at Plainfield, N. J.

**PORT HURON, MICH.**—The Havers Motor Car Company, of which Fred Havers, of Detroit, is president, has increased its capital from \$60,000 to \$200,000. It is now planned to manufacture 1000 cars next year, the first output having been estimated at 500.

**PITTSBURGH, PA.**—The Abbott-Detroit Motor Sales Agency has been organized to handle the Abbott-Detroit in this territory. J. A. Stumpfenhorst, formerly with the Studebaker Company and later with the E. J. Thompson Company, is president.

**COLUMBUS, O.**—The Hudson Sales Company, of North Fourth street, has appointed the following sub-agents: E. C. Fogle Automobile Company, Cambridge, Elmore; D. S. Spangler, Thornville, Elmore; R. E. Wildermuth Automobile Company, Pleasantville, Krit.

**PHILADELPHIA**—The Crescent Garage has taken the agency for the Halladay car, manufactured by the Streator Motor Car Company, of Streator, Ill. The garage will act as distributor for eastern Pennsylvania, and, with T. Sidney Weber, for the state of Louisiana.

**BALTIMORE, MD.**—The Stoddard-Dayton Auto Company, of Baltimore, has taken the local agency for the Sampson truck. The company will represent the truck not only in Baltimore but throughout Maryland, Virginia and West Virginia, the territory covered by the local company.

**DETROIT, MICH.**—F. R. Bump has been appointed assistant general manager in charge of the sales, advertising and service departments of the Hupp Corporation. R. T. Wingo has taken the position of assistant general manager in charge of production and will also act as master mechanic and consulting engineer.

**PROVIDENCE, R. I.**—Robert F. Russell has been appointed assistant engineer of the automobile department of the American Locomotive Company. He will be associated with Montague H. Roberts, chief engineer, in matters pertaining to Alco trucks and cars.

**DENVER, COL.**—The Mathewson Auto Company has appointed the following sub-

agents for the Reo in Colorado: McCune Bros., Las Animas; J. C. Cartwright, Rocky Ford; Royal Garage, Pueblo; Paul's Garage, Colorado Springs; J. B. Smith, Sterling, and O. P. Sells, Alamosa.

**RACINE, WIS.**—The Mitchell-Lewis Motor Company has borrowed \$2,500,000 from banks in Chicago and New York. The purpose of the company is to refund all its banking obligations and to use the remaining capital in opening new departments for the building of tops, bodies and commercial vehicles.

**LOUISVILLE, KY.**—One of the newcomers in the truck manufacturing field of the Middle West is the Transit Motor Car Company of this city, which is engaged in the building of 2, 3 and 4-ton trucks. The Laib Company has bought one of the 3-ton models, which is arranged for carrying long lengths of pipe.

**NEW YORK CITY**—H. Boller will give special automobile instruction in German at the automobile school of the West Side Y. M. C. A., Fifty-seventh street and Eighth avenue. Many of the students at the school are German and it was for their benefit that the new course in that language was added to the curriculum.

**PUEBLO, COL.**—The Byron Motor Company, of Denver, has taken over the plant of the old Pueblo Steel Wheel & Wagon Company and is installing machinery for the manufacture of the Byron truck. The plant will be in operation by January 1, 1918, and will employ 100 men. Its capacity will be 600 trucks a year.

**NEW CASTLE, PA.**—The annual meeting of the Penn Motor Car Company, Pittsburgh, was held here recently. The following officers and directors were re-elected: President, A. G. Breitweiser; vice president and chief engineer, J. S. Herbert; treasurer, J. J. Keeling; secretary and sales manager, C. E. Gregg.

**FOND DU LAC, WIS.**—The Fountain City Garage, erected by M. B. Helmer at a cost of \$25,000, has been opened for business. It is located at 19-21-23 Fourth street, is 40 feet wide and 115 feet long, two stories and basement, of concrete and brick construc-

tion. It is equipped with electric elevators. A complete paint and finishing shop is a feature of the repair department.

**LOS ANGELES, CAL.**—“Doc” Green, formerly sales manager of the Cadillac agency in this city, who left that concern recently, has taken a position with the Grundy Motor Sales Company. He will be sales manager for the Cole and Paige-Detroit lines, for which the Grundy Motor Sales Company is the southern California agent.

**PROVIDENCE, R. I.**—George L. Sullivan, recently automobile editor of the *New York Tribune* and identified with the automobile industry for 5 years, has joined the sales department of the American Locomotive Co. of this city. H. C. Whitney, formerly of the Royal Tourist and Gramm forces, has also become connected with the Alco interests as traveling sales representative.

**MILWAUKEE, WIS.**—The Chas. Abresch Company, Fourth and Poplar streets, has just perfected a new type of sand sprinkler for municipal purposes, which is being tested by the city. The machine sprinkles 50,000 square yards of pavement in an hour, accomplishing the work of fifteen to twenty men with shovels in the same time. But one person is required to operate the sprinkler.

**PHILADELPHIA**—John North Willys, president of the Willys-Overland Motor Company, of Toledo, was the guest of honor at the informal banquet held recently at the Bellevue-Stratford by the Overland-Marion Motor Company of this city. More than fifty managers and agents of the Overland Company from Pennsylvania, New Jersey, Delaware and Maryland were present.

**TORREON, MEXICO.**—The guayule rubber industry in Torreon, Gomez Palacio and other towns of this region is seriously affected by the general labor troubles. More than 10,000 workmen in Torreon, Gomez Palacio and Lerdo went on a strike the early part of November and the trouble is still unsettled. The Intercontinental Rubber Company's production will be much reduced on account of the labor difficulties and the general unsettled conditions.



PASADENA, CAL.—The Acme Garage, 78 Green street, opened recently with Amber McKibbin as manager.

KALKASKA, MICH.—J. L. Boyd has taken the local agency for the Ford and will open a garage and repair shop about January 1.

NEW YORK CITY—The Simplex Automobile Co. has moved into its new salesroom at Columbus Circle.

NEW YORK CITY—G. L. Egan has resigned the position of advertising manager of the Motor Car Equipment Co. and has accepted a position with the Catalog Publishing Co.

TACOMA, WASH.—C. G. Arnold is now associated with the Pacific Car Company of this city in the capacity of sales manager. Mr. Arnold was recently in charge of the Olympic Motor Car Company of Seattle.

HARTFORD, CONN.—During the last year the State of Connecticut has received \$230,120 from car owners and operators. Most of this sum came as registration fees. The gain over the previous 12 months is \$65,000.

OMAHA, NEB.—The Omaha Fire and Police Board has found the combination chemical and hose automobile truck so valuable that it was decided to buy a second one. After receiving bids a Knox car was ordered.

PHILADELPHIA—Benjamin H. Kirkbride, formerly manager of the Reo agency in this city, has taken the eastern distributing agency of the Cutting car. His territory includes Pennsylvania, New Jersey and Delaware.

LOUISVILLE, KY.—The Board of Public Safety of this city has recommended the equipment of an automobile repair shop to take care of the municipal motor cars which have been put in service within the past few years.

SAN FRANCISCO, CAL.—F. L. Chavanne, formerly connected with the local branch of the F. B. Stearns Company of Cleveland, is now associated with the sales force of the Haynes Auto Sales Company of this city, distributor of Haynes and Krit cars.

KANSAS CITY, MO.—Alfred Reeves, sales manager of the United States Motor Company, has succeeded W. S. Hathaway as district manager of the West. Mr. Reeves will continue as sales manager but will have this territory under his personal supervision.

SAN FRANCISCO, CAL.—W. T. Matzer, of Columbus, Neb., accompanied by his wife, daughter and brother, arrived in this city recently in his Buick touring car. The party left Columbus about the middle of September and are on their way to Santa Anna, this state.

APPLETON, WIS.—The Eagle Manufacturing Company has perfected a traction plow which covers 30 acres a day, eight fur-

rows at a time. The company has disposed of part of its other business lines in order to concentrate its entire effort on the engine and tractor business. A large addition to the plant is contemplated.

PHILADELPHIA—The Lee Tiré & Rubber Co., of Conshohocken, will open a branch in this city at 225 North Broad street on Monday, December 11.

NEW HAVEN, CONN.—W. B. Young, recently a member of the sales force of the New York branch of the Ford Motor Co., has accepted the position of manager of the Ford agency in this city.

DETROIT, MICH.—The sales office of the Heinze Electric Co., formerly in Lowell, Mass., has been moved to 870 Woodward avenue in this city in order to bring it into closer touch with the center of demand.

CHICAGO, ILL.—G. Vernon Beck, for several years connected with the Chicago branch of the Studebaker Corporation, in capacity of traveling salesman, has resigned his position to join the sales organization of the Hupp Corporation. Mr. Beck will travel in Illinois and adjacent territory, working with the Chicago branch, of which Mr. H. E. Westerdale is manager.



## Automobile Incorporations

### AUTOMOBILES AND PARTS

BUFFALO, N. Y.—Buffalo Motor Vehicle Co.; capital, \$100,000; to manufacture, sell and repair automobiles. Incorporators: W. R. Hunteley, J. H. Vailm, C. R. Hunteley.

BUFFALO, N. Y.—Pierce-Arrow Sales Co.; capital, \$75,000; to sell automobiles. Incorporators: W. J. Mineban, T. D. Powell, H. W. Huntington.

CAMDEN, N. J.—Generating Light & Motor Co.; capital, \$125,000; to make engines. Incorporators: J. J. Bradym, G. D. Connelly.

CAMDEN, N. J.—Little Giant Motor Co.; capital, \$125,000; to make and sell motor vehicles. Incorporator: William C. Davis.

CHICAGO, ILL.—Motor Bus Co.; capital, \$60,000. Incorporators: Clarence E. Morris, James E. Hauronic, Frank P. Page.

COLUMBUS, OHIO.—Dunlap Mfg. Co.; capital, \$50,000; to make automobile parts and pneumatic tools. Incorporators: S. M. Dunlap, A. I. Schetenstein, T. C. Dunlap, L. F. Slater, B. G. Watson.

DETROIT, MICH.—Metzger Motor Car Co.; capital, \$1,000,000; to manufacture automobiles.

EAGLE GROVE, IA.—Middleton Auto Co.; to sell automobiles. Incorporators: Lyman B. Middleton, Claude E. Middleton.

JANESVILLE, WIS.—Janesville Motor Co.; capital, \$20,000; to make and sell automobiles. Incorporators: G. M. Decker, L. J. Davis, A. Schaller.

MOUNT VERNON, N. Y.—Meteor Automobile Co.; capital, \$50,000; to manufacture engines and automobiles. Incorporators: F. A. Kately, A. F. Gescheidt, L. Emmeluth.

SAN FRANCISCO, CAL.—Atlas Auto Machine Co.; capital, \$10,000; to make automobile parts. In-

corporators: I. B. Dalsiel, H. D. Pressy, N. F. Pressy.

ST. JOSEPH, MO.—Joseph Grassfield Automobile Co.; capital, \$2,000; to sell motor vehicles. Incorporators: E. A. Grassfield, Geo. Vetuske, F. E. Frank, N. C. Salisbury, W. T. Rainey.

WILMINGTON, DEL.—New York Motor Works, Inc.; capital, \$70,000; to manufacture engines.

### AUTOMOBILE GARAGES AND ACCESSORIES

CHICAGO, ILL.—Acme Automatic Tire Pump Co.; capital, \$50,000; to manufacture and sell automatic pumps. Incorporators: Francis J. Carroll, Emil R. Rosenthal, Francis J. Houlihan.

CHICAGO, ILL.—Fort Dearborn Auto Repair Co.; capital, \$1,200; to sell supplies and conduct a repair shop. Incorporators: Albert Campbell, Henry L. Blum, Donald S. McKinley.

CLEVELAND, OHIO.—Metal Body, Tank & Fender Co.; capital, \$10,000; to make bodies, tanks, fenders and other accessories and parts. Incorporators: Charles C. Meyer, Arthur J. Peet, C. J. Robinson, B. A. Perkins, E. J. Hartman, C. J. Indianapolis, Ind.—General Specialty Co.;

capital, \$40,000; to make tires. Incorporators: C. F. Gregg, R. E. Gregg, W. W. Gregg, J. E. Coulter.

NEW HAVEN, CONN.—Knight Garage Inc.; capital, \$15,000; to conduct a general garage business. Incorporators: Harry T. Hotchkiss, George E. Tester, Pierrepont B. Foster.

NEW YORK CITY.—Cosmopolitan Motor Co.; capital, \$10,000; to conduct a garage. Incorporators: John J. Kirby, Albert G. Armento.

PHOENIX, ARIZ.—Milwaukee Auto Specialty Co.; capital, \$75,000; to manufacture automobile accessories. Incorporators: William J. Schubert and others.



New branch house of the Lozier Motor Company in Cleveland, Ohio

# OF INTEREST *to the* INDUSTRY

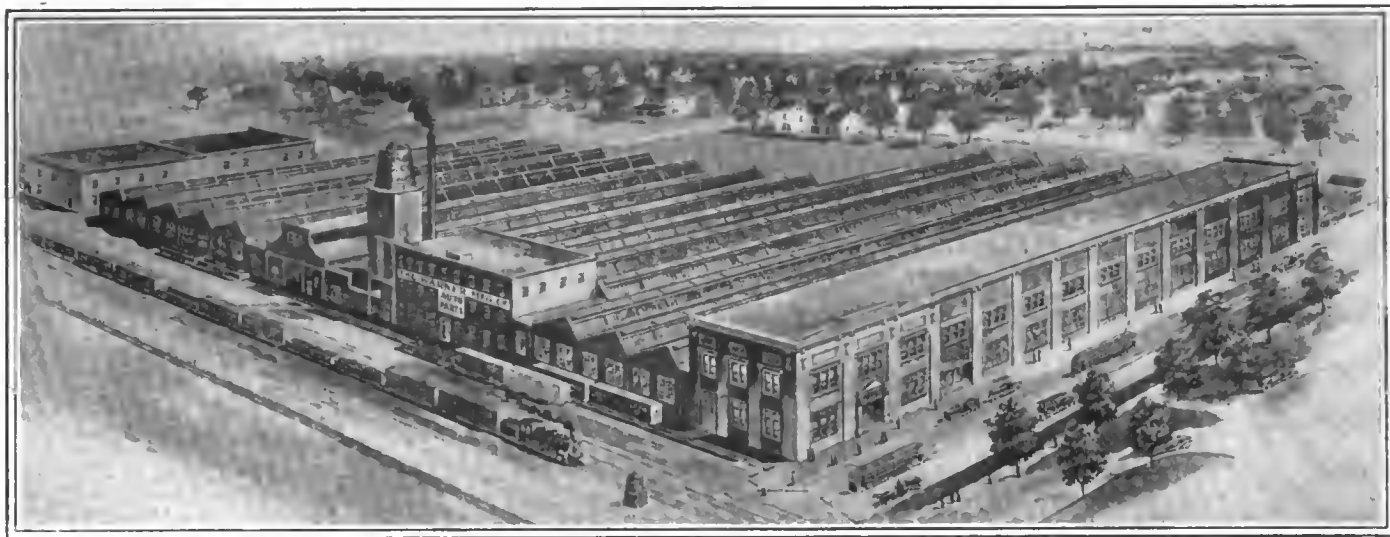

Bird's-eye view of the immense plant of the Warner Manufacturing Company, at Toledo, Ohio

**TOLEDO, O.**—The Warner Manufacturing Co. has completed its new plant which has the capacity for an annual output of 40,000 sliding-gear transmissions and 40,000 steering gears.

**GALT, ONT.**—Canadian Motors, Ltd., is erecting a factory in this city, to cost \$4,000.

**TORONTO, ONT.**—The Russell Motor Car Co. is building a factory in this city, to cost \$30,000.

**LOUISVILLE, KY.**—The Longest Bros. Co., of this city, has completed the equipment of its shops for the manufacture of motor trucks.

**NEW BRITAIN, CONN.**—The Corbin Screw Co. is manufacturing a newly patented speedometer for automobiles along with its other products.

**DETROIT, MICH.**—Kahn & Wilbay, architects, are preparing plans for a one-story addition to the plant of the Chalmers Motor Co. The structure is to be 177 by 70 feet and will cost \$25,000.

**BROCKWAYVILLE, PA.**—The Universal Electric Manufacturing Co., of this city, will manufacture among other electrical appliances the Universal Electric Motor, of which Dr. E. B. Cotten is the inventor.

**DETROIT, MICH.**—The Cadillac Motor Car Co. has awarded contract through R. D. Raseman, architect, for the construction of a large warehouse and a three-story brick power-house adjoining its present plant.

**NEW CASTLE, IND.**—The Whiteside Motor Truck Co., formerly of Franklin, Ind., has been reorganized and recapitalized and is now located in this city, where it purchased the plant of the Safety Shredder Co. The new plant will enable the company to turn out 1,000 cars per year.

**APPLETON, WIS.**—The Valley Iron Works has made a large installation of the oxy-hydric cutting and welding apparatus manufactured by the American Oxhydric Co., of Milwaukee, and will do automobile and truck repair work in this territory.

**OSHKOSH, WIS.**—The Termaat & Monahan Co., manufacturing gas and gasoline engines and motors, has purchased the Oshkosh Boat Works site and is erecting a new foundry, to be L-shaped, each wing 50 x 125 feet in size. The present foundry will be added to the machine shops.

**INDIANAPOLIS, IND.**—The Premier Motor Manufacturing Co., of this city, has begun the manufacture of gasoline motor trucks. The recent enlargements to the plant of the company enable it to take care of a substantial truck business in connection with the manufacture of pleasure cars.

**DERBY, CONN.**—The United States Rapid Fire Gun & Powder Co. is changing part of its shell department's quarters into a factory for the manufacture of the Westinghouse air spring for automobiles. George Westinghouse is the inventor. The device consists of a piston which works against a cushion of air in a vertical cylinder.

**ALEXANDRIA, VA.**—V. M. Palmer, formerly superintendent and chief engineer of the Selden Motor Vehicle Company, of Rochester, N. Y., and recently chief engineer and manager of the automobile department of the Sheldon Axle Company, Wilkes-Barre, Pa., has taken the position of factory manager and chief engineer for the B. F. Board Motor Truck Company, of this city.

**RACINE, WIS.**—Three new departments will be established at once by the Mitchell-

Lewis Motor Company, of Racine. One will be for the production of commercial vehicles, the second for the manufacture of bodies and the third for the manufacture of tops. Heretofore its bodies have been built in Milwaukee and Racine by outside interests. The line of commercial cars will include a light delivery car and a general utility farm truck. The total production of all cars for 1912 will be 6,000, the largest in the history of the concern.

**DETROIT, MICH.**—Although November is usually the duller month in the year for the industry, the Chalmers Co. has been putting on additional men during the past two weeks and is spending considerable money in the way of betterments. It has just completed a large extension to the motor assembly department and is now installing increased facilities for the testing of motors. The pressing need for additional manufacturing space has made it necessary to move all the offices to a lower floor, crowding them in together. In addition to these changes the company is preparing to erect a new warehouse.

**MISHAWAKA, IND.**—The Simplex Motor Car Co. has decided to manufacture a moderate priced car and the engineering force is now at work on plans which, when completed, will be turned over to the mechanical department. The new car is to be known as the 40 Baby Amplex and will be equipped with a five-passenger body. The engine to be installed in the new car will be of the four-cylinder, two-cycle valveless type. The capacity of the plant will be increased from the present output of 300 cars to 1,300 cars per annum. Of the 1,300 cars turned out 1,000 will be of the Baby Amplex model.

# PATENTS GONE TO ISSUE

**CLUTCH**—In which cross heads held under tension by springs keep the clutch members in engagement.

3. In this mechanism (Fig. 4) an annular member is keyed to a shaft on which also a revoluble element is loosely journaled and provided with a casing surrounding the annular member. The casing has a number of outwardly radial-projecting boxings, in which spring-tensioned heads are slideably located. Clutch members having fiber clutch shoes are provided with link connections with the cross heads to engage the annular member, when the revoluble element is revolved. Means are provided between portions of the cross heads and the links, which hold the clutch members steadily in engagement with the annular member.

No. 1,009,219—to James C. Boyle, Calgary, Alberta, Canada. Granted November 21, 1911; filed May 17, 1911.

**AUTOMOBILE HEATER**—Device for heating the interior of closed types of car.

3. The patent relates to the combination of a frame, to the bottom and top of which plates are attached, with heat insulating material on the lower plate and on the frame, frame and plates being so arranged as to form a chamber between upper plate and insulating material. Strips extend from one side of the frame to the other and rest of the sides of the frame and on the heat-insulating material. Supports are provided in the chamber between upper plate and strips and means to hold plates and strips to the supports and to force the strips down onto the insulating material so as to maintain the latter in place.

No. 1,009,052—to Otto Cullman, Chicago, Ill. Granted November 21, 1911; filed December 14, 1910.

**VALVE**—Double cylindrical type of sleeve valve is reciprocated in the cylinder.

5. In this engine (Fig. 1) a stationary

sleeve is fitted in the valve casing which has a delivery passage to the cylinder. The sleeve has delivery and exhaust ports aligned with the delivery passage. A hollow cylindrical valve is mounted to reciprocate in the sleeve, having ports which lead from the interior to the outer surface of the sleeve. These ports are adapted to register with the delivery ports in the sleeve when the exhaust ports are closed by the valve. A ring fits closely around the valve and is carried by it through a portion of its stroke, and means are provided to limit the movement of the ring to a fixed space, so that the exhaust gases are prevented from passing into the body of the valve while the ports therein are passing into the body of the valve while the ports of same are passing the delivery ports in the sleeve on the stroke of the valve conforming to compression and power stroke of engine.

No. 1,009,599—to Charles N. Teetor, Hagerstown, Md. Granted November 21, 1911; filed August 17, 1911.

**HEADLIGHT ADJUSTER**—Arm and leverage connection for regulating the position of a headlight on an automobile.

1. The patent refers to a lamp (Fig. 2) mounted with provision for horizontal oscillative movement, an arm being connected with the laterally moveable steering (front) wheels so as to have a similar angular movement as these wheels, and an intermediate connecting rod having universal pivotal connection with the lamp at a point in line with the axis of oscillative movement. Thereby the rod is rotated about its own axis by the angular movements of the arm aforementioned, transmitting rotation to the lamp in the same direction.

No. 1,009,385—to Frank R. Cunningham, Medford, Mass., assignor to Kendrick & Davis Co., Lebanon, N. H. Granted November 21, 1911; filed December 7, 1909.

**GOVERNING DRIVING MECHANISM**—Device for regulating the activity of engines.

2. This patent (Fig. 3) relates to the combination with a driving and a driven element, of a flexible power-transmitting coupling between these elements responsive to variations in torque. The coupling comprises a link and a weighted lever, power regulating means being connected to the lever as well as means whereby the lever varies in position according to the difference between the driving force and load.

No. 1,009,706—to Geo. A. Weber, Trenton, N. J., assignor to Carl J. Adam, Trenton, N. J. Granted November 21, 1911; filed November 25, 1910.

**TAIL-LIGHT AND NUMBER PLATE**—Apparatus for displaying number and light.

This patent refers to a device comprising a case with an opening on one of its sides, a bull's eye being provided on one side of the opening. Lighting means are contained in the case, as is a number display plate and elastic means for holding it against the inner wall of the case which has the opening in it. The elastic means consist of a flat spring having a number of bearing faces engaging the inner side of the number plate next its upper edge, and a similar spring which engages the inner side of the number plate against the lower edge.

No. 1,009,470—to Davis S. Cake, Los Angeles, Cal. Granted November 21, 1911; filed March 16, 1910.

**RADIATOR**—Being of vertical tube type.

4. This radiator has top and bottom members and side walls having corrugations connected to these members; in the corrugations are located reinforcing members of a U-shaped section, the inner sides of the U-shaped sections being connected by a strut.

No. 1,007,643—to Fred Clare, Preston, Ontario, Canada. Granted October 31, 1911; filed September 14, 1910.

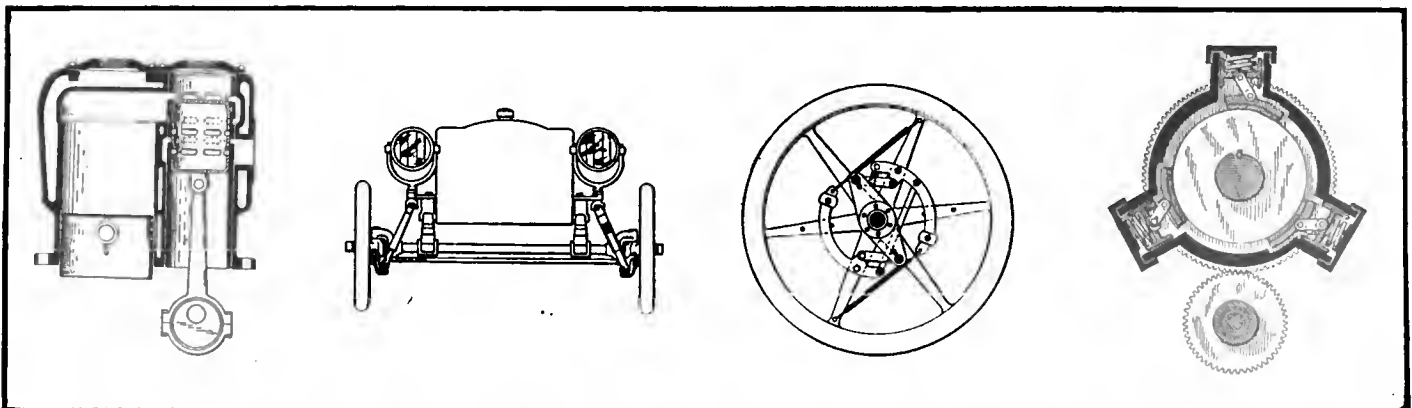

Fig. 1—Teetor sleeve valve. Fig. 2—Cunningham lamp adjuster. Fig. 3—Weber mechanism for drive control. Fig. 4—Boyle clutch

# Newest Ideas Among the Accessories

## Cinch Repair Kit

**T**HE Cinch tire repair equipment which is illustrated in Figs. 1 to 3 on this page is manufactured by the Cinch Repair Kit Company, of Lockport, N. Y., to enable the motorist to make quick and lasting repairs on inner tubes which have been made useless by blowouts. The exterior view of the kit is seen in Fig. 1. The dimensions of the outfit are 7 by 4½ by 1 inches, and the case in which the several tools composing the equipment are kept is of black leather.

The contents of the kit are seen in Fig. 2, showing the case opened and outspread, and thus giving an idea of the neat and compact manner in which the various tools are arranged. Each tool is held in place by a leather strip securely fastened to the case.

Fig. 3 shows the various tools and the plugs which serve for making the repair. The nickel tube contains a dozen plugs, as shown in the figure. These plugs are made of a soft metal skeleton of the form here seen, and the skeleton is covered with solid rubber, resulting in exactly the shape of the plug at the right. Each plug has a flat and a rounded side.

The pliers are so constructed that by their use the plugs may be compressed, resulting in a solid patch as the left one. By the process of compressing the plug its metal stem is crushed and a tight joint is made between the inner surfaces of the two circular sections.

If the Cinch outfit is to be used for repairing a hole in an inner tube it is not necessary to jack up the car and remove the tire from the wheel. All one has to do

is pull the damaged portion of the tube out of the casing and then proceed as follows:

The irregular hole is put in shape for the application of the plug. This is done by pushing the point of the cutting tool through the hole in the tube, until a clean round opening is formed therein. The hole made by the tool is much smaller than the diameter of the plug, and a little wider than the stem holding the two round plug sections together. Therefore the wire spreader is used for widening the hole in the tube. The wire is compressed until its two ends come together, after which the instrument is inserted into the enlarged puncture and permitted to widen it.

Then, while the wire holds the hole in a state of tension, the plug is inserted in it with the rounded side outward. Hereafter the wire spreader is withdrawn and the rubber allowed to contract around the stem of the plug. This having been done, the tube is folded so that it is possible to compress the plug by means of the pliers. Then the same operation is done with the pliers reversed, so as to insure equal pressure being dealt to all portions of the plug. When the repair is finished the tube may again be placed back in the tire.

The metal skeleton in the plug has no sharp edges. All the edges are copiously covered with solid rubber, which insures the inner tube against cutting by the metal core. When it is compressed the tensile strength of the rubber plug is many times in excess of the force required to keep the puncture in the tube closed. This is the reason for the Cinch plug being able to keep a tube in a satisfactory state for

months after it has been repaired. The application of sheer force in installing the plug has an effect much different from repairs relying upon mere adhesion.

Not only does the plug work well, but the operation of putting it in place is very simple and takes a very short time. If the location of the puncture is known, all one has to do is to pull the damaged portion of the tube out of the casing, apply the plug, return the tube in its correct place and inflate the tire. Excepting the last-named operation, the whole work may be done in about 1 minute, and it is easy enough to be performed by a boy of 8 or 10 years.

The advantages of this kit are manifold. Not only is it handy enough to be carried in the motorist's pocket, without a chance of losing any one of the pieces making up the equipment, but the fact that the use of this kit enables one to make a repair on the road without the application of heat make it a useful accessory. Everybody is not deft nor careful enough to execute a good quick vulcanizing job, but the simplicity of the Cinch outfit makes it a foolproof equipment indeed.

## Start-Light Illumination

In the description of the above-mentioned lighting system on page 838 of *THE AUTOMOBILE* of November 9 the idea was created that in this illuminating system two motions were required for putting the system into action, namely, that it was necessary to throw on the gas and then the igniter for the lamps. This is not so, but a pressure on a single button admits both acetylene and spark to the lights of the car.

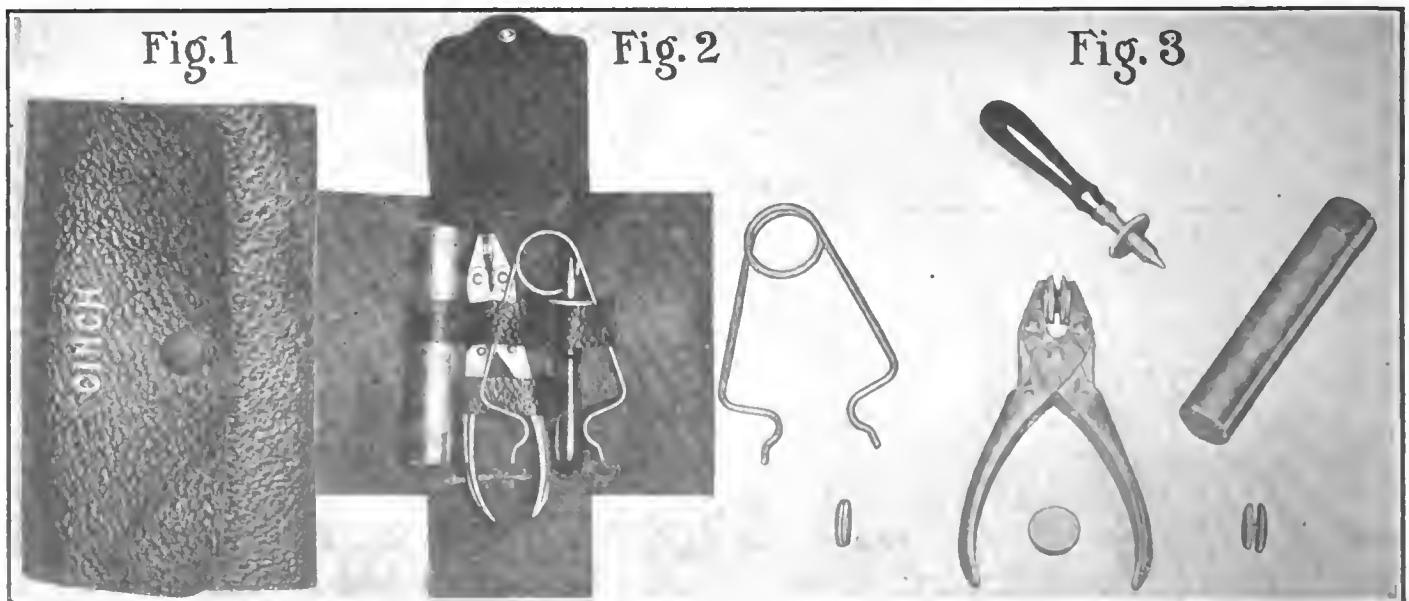
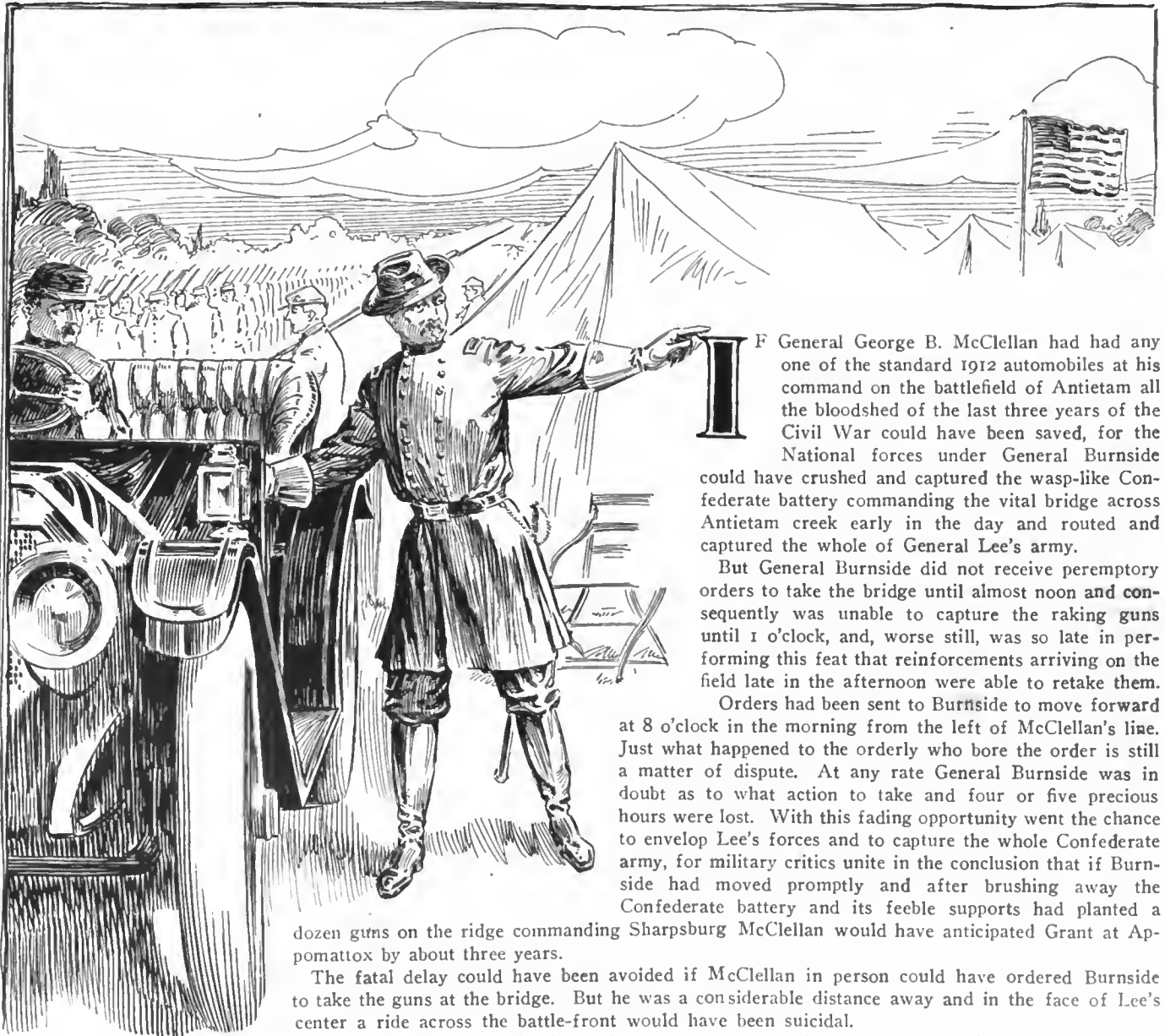

Fig. 1—Outside view of the Cinch tire repair kit. Fig. 2—Kit unfolded showing arrangement of contents. Fig. 3—Display of repair plugs and tools



# THE AUTOMOBILE

## Automobile Might Have Altered Map



**I**F General George B. McClellan had had any one of the standard 1912 automobiles at his command on the battlefield of Antietam all the bloodshed of the last three years of the Civil War could have been saved, for the National forces under General Burnside could have crushed and captured the wasp-like Confederate battery commanding the vital bridge across Antietam creek early in the day and routed and captured the whole of General Lee's army.

But General Burnside did not receive peremptory orders to take the bridge until almost noon and consequently was unable to capture the raking guns until 1 o'clock, and, worse still, was so late in performing this feat that reinforcements arriving on the field late in the afternoon were able to retake them.

Orders had been sent to Burnside to move forward at 8 o'clock in the morning from the left of McClellan's line. Just what happened to the orderly who bore the order is still a matter of dispute. At any rate General Burnside was in doubt as to what action to take and four or five precious hours were lost. With this fading opportunity went the chance to envelop Lee's forces and to capture the whole Confederate army, for military critics unite in the conclusion that if Burnside had moved promptly and after brushing away the Confederate battery and its feeble supports had planted a

dozen guns on the ridge commanding Sharpsburg McClellan would have anticipated Grant at Appomattox by about three years.

The fatal delay could have been avoided if McClellan in person could have ordered Burnside to take the guns at the bridge. But he was a considerable distance away and in the face of Lee's center a ride across the battle-front would have been suicidal.

During the recent Glidden Tour the caravan was routed through the battlefield of Antietam and the possibilities of the automobile to a general in McClellan's predicament were made very apparent.

The commanding general was stationed behind Porter's troops in the center, fully three miles from Burnside. The whole space between his headquarters and Burnside was swept by Confederate cannon. But running southeast from his headquarters and away from the battle front lay the Shepherdstown pike, a fair stone road even in those days. This road circles back from Antietam creek and forms a junction with the pike road crossing the very bridge in Burnside's front.

With a powerful automobile General McClellan could have started from the center as soon as it was discovered that Burnside had



not swept over the bridge at 8 o'clock and by traveling not more than 10 miles, a matter of probably 15 minutes' driving at most, could have appeared in person to direct the charge. He could have changed commanders on the field if he had so desired or he could have taken active charge of the movement himself.

Throughout the trip from his headquarters to the left of the line he would not have been under fire for a minute and by his presence he could have insured the success of the advance.

At the time Stonewall Jackson's division had been driven back on the right and with Mansfield's and Sumner's corps the National troops engaged were gradually enveloping the Con-

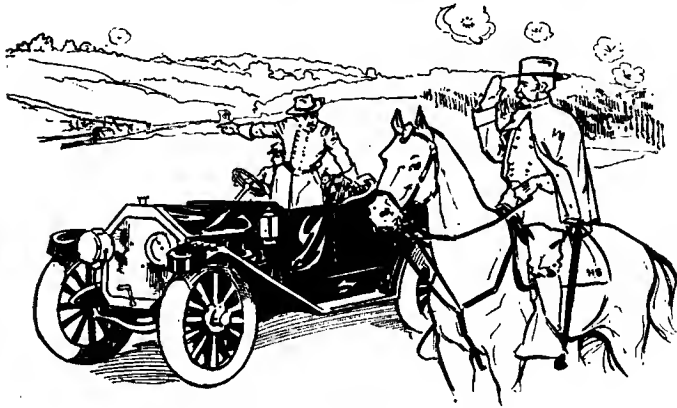

Equipped with a fast headquarters car McClellan could have reached the bridge in 15 minutes and taken charge of the field in person

federate left. One sharp charge, one rush order for three batteries of artillery and Lee's army would have been caught in a trap with 70,000 men surrounding their front and the Potomac river behind.

It was a great opportunity and would have crushed the Confederacy three years before that event finally happened. It would have saved billions in money and hundreds of thousands of human lives, but unfortunately the automobile was not invented at that time.

On the Glidden Tour the cars moved slowly across this battlefield on their way from Gettysburg to Staunton. Practically all the way the caravan crossed fields that were once devoted to human slaughter. Of course it was vain to consider such things, but there was many an old soldier, or the son or grandson of an old soldier, who could not refrain from drawing some comparisons as to what the automobile would have meant to any of the commanders in the Civil War.

Starting at Gettysburg, every field presented some opportunity for discussing the problem of transportation as applied to military operations.

At Gettysburg, one of the tourists who commanded a company in Longstreet's army presented the other side of the picture. He said that if General Lee could have delayed Pickett's marvelous charge against Hancock's corps for 1 hour and could have continued the artillery battle with the Federal guns for that length of time when the charge should have been ordered it would have cut through the weakened line of blue and served as a wedge, making an opening by which the soldiers of Longstreet could have poured eastward toward Philadelphia after routing the National army.

But General Lee was several miles from the scene of the charge and the silencing of the Federal guns on the crest of the ridge deceived him as to the effect of the Confederate artillery fire. The charge took place as ordered and despite Lee's futile efforts to cause its delay for that one important hour. The Confederate commander realized after the arrangements had been made that the cannon fire had not been continued long enough and if he had had at his service a fast automobile to convey him or one of his aides to check the infantry charge until the guns had finished their work, there is more than a strong possibility that the cause of the South would have scored heavily. At this particular moment a great victory for Lee

would have resulted in recognition of the South as a belligerent by one or more great European nations and its actual effect upon the North would have been profound.

Crossing into Virginia and entering the Shenandoah valley, the opportunities for changing the whole political complexion of the nation if either side had been equipped with the ordinary touring cars of 1912 are impressive.

If General Jubal A. Early or General Sheridan had had a good fast touring car on the route followed by the Glidden Tour in 1911 the Confederacy would have been prolonged indefinitely or crushed promptly, depending upon which side possessed the car. Early could have captured Custer's division one day early in the final campaign in the Shenandoah if he could have had just 10 minutes' start in throwing one of his cavalry brigades between the Union troops and the Potomac river. An automobile circling to the rear could have conveyed the commander or his aide to the officer in charge of the brigade and started the well-planned movement to take Custer's soldiers that was only frustrated by a trifling delay on the part of the investing column. But Custer, alert to his danger, managed to take and hold the crossing of the Potomac long enough to allow his forces to escape from the superior force.

If this movement could have been accomplished Lee could have withdrawn Anderson's command, which had been sent to reinforce Early, and there would have been just that many more seasoned veterans to face Grant at Spottsylvania, Cold Harbor and the subsequent engagements. It also would have weakened Sheridan so that the ultimate destruction of Early could not have seen accomplishment in the way that actually happened.

The battle of Winchester would have proved the last fight in the valley if Sheridan could have ordered up his second line one hour earlier than he was able to do using mounted orderlies. This delay allowed Early to concentrate his forces and prevented a much worse Confederate defeat than was suffered.

If at this juncture General Lee had been able to double the reinforcements sent to Early there might have been a different story to tell, but owing to the lack of definite information in the possession of the Confederate commander, all of which could have been conveyed to him if there had been a good, fast automobile at hand, when Early's partial reinforcements did arrive and he started to drive Sheridan back through the valley his force

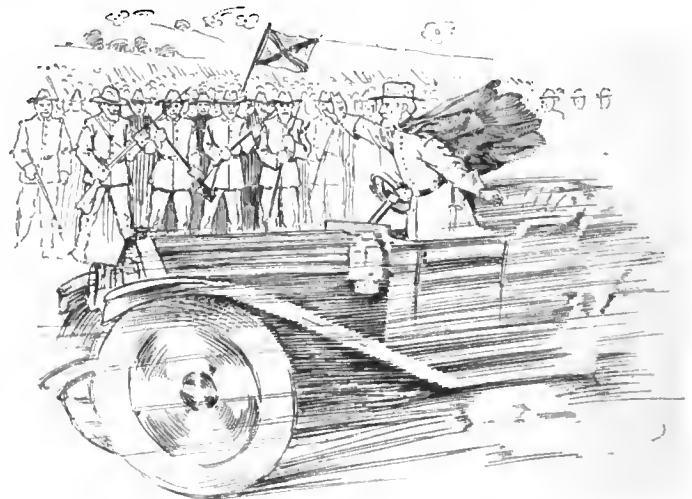

With a fast automobile Lee might have delayed Pickett's charge for one invaluable hour and avoided the Gettysburg reverse

was still so small that the Confederate leader showed he was not confident of accomplishing his purpose.

Sheridan's main body of infantry was at Harrisonburg, the funny little village where the Glidden tourists were held up for speeding. The troops slowly retired toward the north, burning everything edible and destroying all property except the houses. This continued to Cedar Creek, which lies some 20 miles south of Winchester, where Sheridan took up a strong position and awaited the approach of the enemy.

At this period of the campaign the authorities at Washington, unable to communicate at length with Sheridan, ordered him to appear at the capital for conference as to the conduct of the campaign. One automobile would have removed the necessity for this trip and made unnecessary the spectacular consequences that resulted from the absence of the commander.

It appears that the work of devastating the valley had been done so completely by the retiring Northern troops that Early could find little food for his men and horses and was forced to take immediate action or retire from the valley. In the still of the night Early moved out from his position to the south of Strassburg and before the Union troops were aware of this action, he had flanked the advance corps. The gray column faced to the flank and dashed in upon the unready Federals, rolling the disordered regiments together and throwing the whole army into such confusion that it seemed that the National army would be routed.

Sheridan had returned as swiftly as possible from Washington and had arrived at Winchester when he heard the dull booming of Early's artillery. Instantly the youthful general was in the saddle and dashing for the battle line.

Gallant and speedy as his great black charger proved himself, the progress of the general was necessarily slow. For a full hour Early's hungry soldiers plundered the captured position of the Union troops and occasionally desisted long enough to break some northern regiment that tried to retire in some sort of regular formation.

The Southern troops were about ready to plunge after the retreating enemy when the slight, young Sheridan mounted on a badly exhausted horse came to the mob of retreating soldiers and shouted orders for them to rally and face about. Sheridan was on time—just on time. He proved himself to be a resourceful officer and took advantage of all the facilities within reach.

He turned the tide of rout into a last desperate stand and while the front of battle held the charging Early the reserves rallied behind the line and then were added to the resisting column. At the critical moment the gray host began to waver and Sheridan ordered forward his cavalry, breaking the assaulting lines and sending Early whirling up the devastated valley.

But—if Sheridan had had one 40-horsepower automobile, like any of two score in the Glidden column. If that automobile had been lying at Winchester ready to do his bidding at a second's notice. Then Sheridan's ride from "Winchester 20 miles away" would have read somewhat differently.

Instead of riding his big black horse at the break-neck speed of 15 miles an hour, the general simply would have said to his chauffeur: "James, this is not Harrisonburg, hit it up a bit, we are due at Cedar Creek in 30 minutes."

James would have touched the self-starting lever, dropped in his clutch and with a skillful shift of the gears would have been in high within 100 yards. Then, with James' foot on the throttle-lever, the General's car would have streaked it for Kernstown. The valley pike was in good shape in '64, the 4 miles could have been done in 5 minutes. From there to Stephens City, another 4 miles, there was a little more difficulty and it probably would have required 6 minutes. But to Middletown the road was found to be fine again and 4 miles would be reeled off in 4 minutes.

At Middletown, according to history, Sheridan met the first of the routed troops. He could have ordered James to slow down to a regular Mount Crawford gait while he rallied the panic-stricken soldiers, taking probably 1 minute to do so. Then James could hit it up once more to Strassburg, needing probably about 5 minutes to make the 4 miles, on account of the sharp grade and toll-gates to be found near that place. Here the general would be in the midst of the routed Northern troops and he could profitably spend 3 minutes in telling them how many different kinds of idiots they were, as he is reputed to have done when he rode into Strassburg in '64.

Cedar Creek and Early's famished hordes lay just about 4 miles to the South and the presence of the general in his auto-

mobile undoubtedly would have caused much more speed in rallying. Then the final dash might have occupied 6 minutes. The whole trip, rallying time and all, need not have been more than just 30 minutes, while in actual time Sheridan's ride took 2 hours.

Minutes are valuable in battle just as they are at a fire. It is the first 5 minutes at a fire that counts and it is the first hour in a battle, particularly when there is a chance to prevent a rout or to destroy an enemy.

If Stonewall Jackson had a car in 1861, there would be slavery in New York to-day if such a result had been the object of the campaign. If McClellan had an automobile at Antietam, Lee would have succumbed right there. If at nearly any one of fifty critical periods on either side during the war one of the commanders had been possessed of a standard touring car of 1912 type, the battle could have been reversed in its outcome, with all that such a result might mean. Naturally, in the next war both sides will be equipped with automobiles for messenger and other service and the advantage to be gained by sole possession of a car would be lost. Consequently the purpose of this fanciful article is to show the difference between transportation conditions in the Civil War and as they are to-day with respect to the automobile.

As a matter of cold, hard fact the Civil War never could have occurred if the automobile had been invented 50 years before the time it was.

History shows that almost all war has resulted from misun-

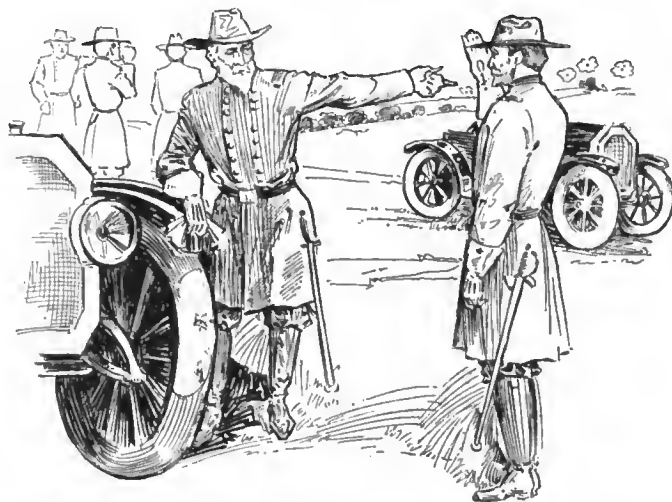

General Early, with a fast car at his disposal, could have overcome the 10 minutes' time which enabled Custer to slip from his net

derstanding, and as the automobile demands good roads and as good roads make for better understanding among residents of different sections, the automobile would have served to prevent hostilities.

During the recent Glidden Tour this point was well illustrated. The column contained practically half and half of Northerners and Southerners. In the North, the Dixieites learned that their countrymen of New Jersey and Pennsylvania did not grow horns and had no hoofs, while south of Mason and Dixon's line the Yankee tourists discovered that the people of Virginia, the Carolinas, Georgia and Florida were human beings with practically all of their own ambitions, hopes and aspirations.

Before, during and for 20 years after the close of the war there was no such understanding.

Of course, the Glidden Tour was only one small enterprise when compared with the sum total of intersectional communication based upon the automobile, and the lessons taught by it are of relatively small importance except as illustrations.

In the United States touring is classed among the highest grades of pleasure. It is growing more and more general each year and conjectures as to its future development are interesting.

In the days of Marco Polo nothing whatever was known about the outside world, except by a few sailors and adventurers, and as a result of the dense ignorance of that period every valley, river, and mountain that was not directly in contact with present observation was peopled with dragons, giants and spirits by the imagination of the inhabitants of every other valley, river, and mountain.

During the period of Roman supremacy, all other nations were deemed barbarians. Before the American Revolution the British monarch and most of his advisers considered the Americans criminals, descendants of criminals and generally inferior.

At the outbreak of the Civil War, the North considered the majority of the residents of the South as being ignorant, illiterate and of small importance, while the remainder were arrogant, overbearing, slave-owning aristocrats. On the other hand, the South looked upon the North as being hopelessly common and commercial, with a strong bent for stealing what the South considered personal property and a general tendency to interfere with things in which the North had no concern.

Senator Hoke Smith of Georgia, the leading advocate of good roads in the South, has stated distinctly on many platforms that the war could not have occurred if good interstate roads had been in existence. As the beginning of good interstate roads dates from the vogue of the motor car, and should be credited exclusively to the motor car, the influence of the car in spreading knowledge and as a deterrent to war must be acknowledged.

Another thing that the automobile has accomplished is in the way of colonization. - To-day the South is dotted with communities less than 5 years old that have a distinctly Northern element in their population. The automobile has already demonstrated its service as a means of solving some of the problems of congested urban life. The very process of such demonstration has served to show the possibilities of country life and this has done a large work in bringing about the colonization referred to.

In southern Georgia and at many points in Florida there are new agricultural developments that may be credited in large measure to the automobile. One particular instance found in north Florida may be cited: The community referred to consists of 57 families, 32 of which came from the North. In this community there are 14 automobiles of various types and at Jacksonville it was learned that six other families are considering the purchase of cars next spring. Needless to say the roads of that particular community are different from those in other places along the sand belt.

To sum up the whole situation in sequence: The mission of

the automobile is worldwide. The automobile is useless without good roads. Therefore, the automobile brings good roads. Good roads mean easier communication between states, cities and communities. Therefore, the installation of good roads means quicker transportation of agricultural produce to market; added intelligence applied to the production of the fields; better and cheaper transportation of manufactured merchandise back to the communities and greater care in the manufacture of the goods demanded by the citizens of such advanced communities; more wealth all around and increased joy in living and working.

### Italy and Austria Using War Automobiles

Italy, in getting upon her war legs, made it her first duty to equip her army with every modern convenience for the conduct of her campaign against the Turks in Tripoli. She has added the automobile to the general outfit, placing a number at the service of the Red Cross corps. But she is not going to stop here. She will add motor-ambulances to the original complement, thus facilitating the work on the battlefield.

Austria's military budget for 1911, as laid before the delegations in Buda-Pest, embraced estimates for supplying the entire Austrian army with automobiles as a means of transport. Already the system has been made a certainty in some quarters, and it will not be a great while before the entire sixteen army corps of the Austria-Hungary forces will be traveling, whenever occasion demands, in automobiles. This decision was arrived at by the War Office at the close of a series of severe and exhaustive try-outs in Vienna and Buda-Pest, the trials having involved the use of automobiles with a carrying capacity of loads weighing from four to eight tons. After a considerable number of tests it was found that loads of this capacity were too heavy to be dragged over the country roads, bridges, the drains in the towns and the underground conduits. The War Office has finally adopted an automobile of two tons carrying capacity.

**THE LOOKING-GLASS AS AN ACCIDENT PREVENTER**—The authorities in Colchester, Essex, England, have inaugurated an odd custom by erecting huge mirrors at road junctions, with a view to reducing chances of accidents between automobiles coming from opposite directions. The mirrors are arranged at such an angle that drivers of motor cars and other vehicles are able to see any sort of an equipage coming around the corner.

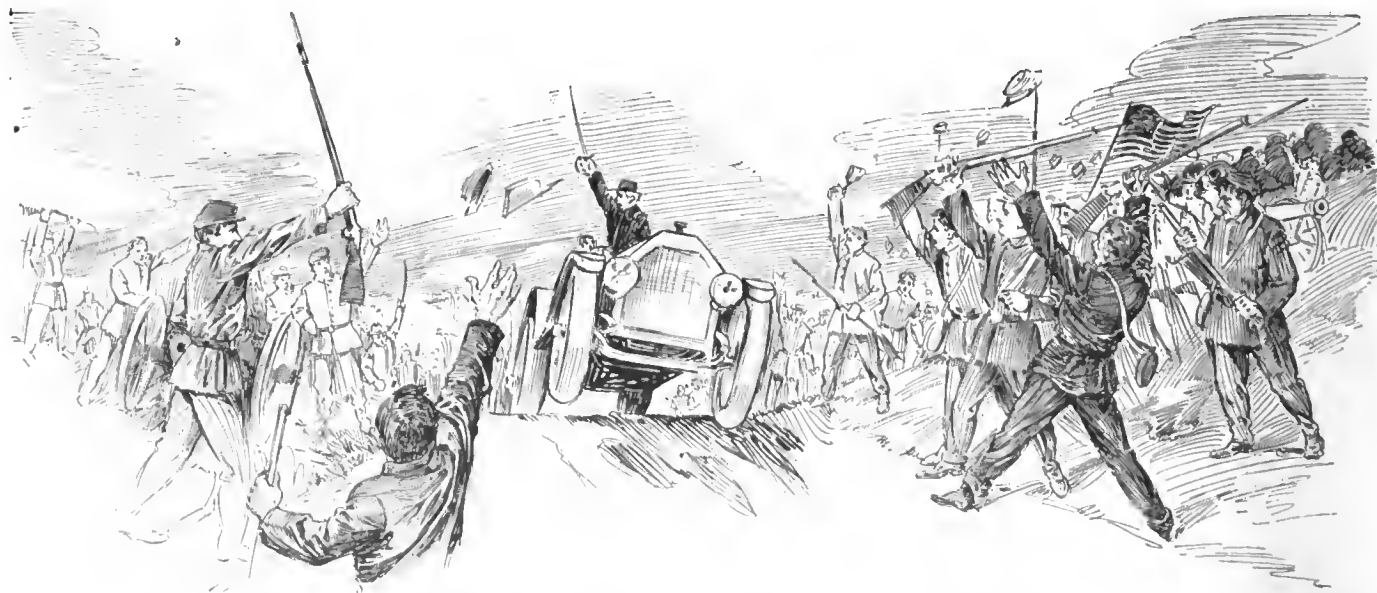

Had automobiles been in vogue 50 years ago Sheridan's "20 miles away" could have been covered in almost as many minutes and the Union rout checked much earlier

# All Motordom Awaits the Shows

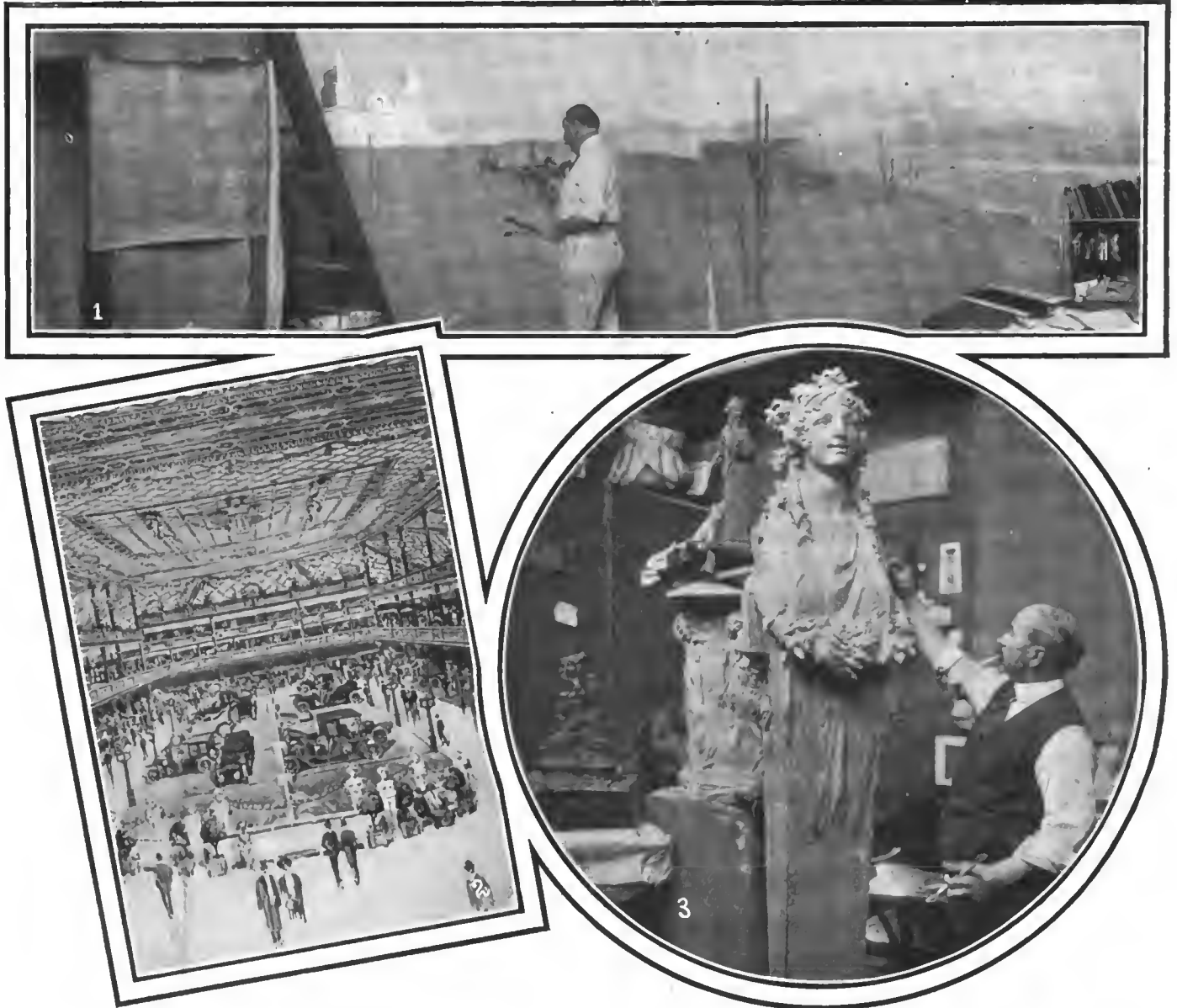

1—Jean Paleologue, famous French artist, painting scene of Lower California for Garden decoration. 2—Center section of Garden, showing decorative scheme. 3—Philip Martini executing plaster creations for Garden Show

**I** NTEREST in the approaching season of shows is the most potent force in the automobile world just at present. Touring is done for the time being, at least, as far as it is of national importance; sporting events are now history and even the excellent buying that has been noted throughout the fall has slackened perceptibly in anticipation of the new lines and new ideas that will be presented at the shows.

In some ways the decorative scheme that will be carried out at Madison Square Garden will be more wonderful than ever before. The formal lines of the Egyptian school will be followed, but in the coloring there will be more than a tinge of the oriental. The mural decorations will be exceedingly elaborate, the center piece being a California sunset. Martini, the celebrated sculptor, is in charge of the statuary designing.

The color plan of crimson and gold will lend itself in rich

and striking ways to the general effect. With a big force at work on the preliminaries and a regiment of men waiting for the word to tear out the unnecessary portions of the interior of the building and replace them with the steel framework required, the big building can be quickly metamorphosed from a bicycle track and converted for the last time into the stage-setting for a great automobile show.

The bicycle racers hold forth there for the rest of the week but after the close of the races there is nothing of great importance scheduled before the show.

To an even greater extent than usual will the racing drivers be featured at the last Garden show. Mulford, Grant, Disbrow, Aitken, Wilcox, Harroun, Dawson, Patschke, Belcher, De Palma, Basle, Jagersberger and numerous other well-known racing pilots will be on hand to sell cars they, have driven.



Over at the Palace final preparations are being pushed forward rapidly. Special emphasis will be laid on the commercial vehicles. A most interesting tabulation has been compiled by the management to show that trucks and delivery wagons propelled by gasoline engines are being used by 200 different branches of industry.

A vast invitation list is being prepared for the N. A. A. M. and Board of Trade shows. In the commercial car section it is said to contain from 80,000 to 100,000 names, all users or prospective purchasers of business vehicles.

An interesting tabulation is the one that deals with the classification of the cards left by visitors at the Garden show last winter and during the commercial week at Chicago. These cards number 3,300 and show that the visitors who left them belong to 53 general lines of industry which were purposely left broad in order to include them all. Of these the building and contracting branch was best represented with 247; metal manufacturing 194, and ranging down from there to flour milling, which was represented by 11 visitors. The professions were not considered in making up the list.

### Importers' Salon Will Show 17 Foreign Cars

Seventeen different makes of foreign-built automobiles will be exhibited at the Importers' Automobile Salon, which is to be held in the Grand Ball Room of the Hotel Astor, New York, from January 2 to 10. Included in this number are, with one exception, every well-known foreign car which has achieved distinction either here or abroad. S. Kjeldsen, who managed the Salon last year and made it such a pronounced success, is at the helm again this season.

The forthcoming exhibition will be strictly a drawing room affair and not an industrial show. Commercial vehicles are excluded and a leading feature will be the magnificent bodies, mounted on the various cars which will exemplify the latest productions of the famous coachbuilders of Europe and America. Four of the latter, by the way, will have separate exhibits.

Over 20,000 square feet of floor space is available in the ballroom and the decorations are superb.

The various makes of automobiles to be exhibited are the C. G. V., Darracq, De Dion Bouton, Panhard and Renault from France; the Benz, Mercedes and Opel from Germany; the Isotta, Itala, Lansia and S. P. A. from Italy; the English Daimler and Napier from England; the Metallurgique and Minerva from Belgium, and the Pic-Pic from Switzerland. The body builders exhibiting are Demarest & Co., the Holbrook Co. and Quinby & Co.

### Philadelphia Show Spaces Allotted

PHILADELPHIA, Dec. 9—The results of the drawings for space at Philadelphia's eleventh annual automobile show were announced yesterday, showing that 43 dealers will be represented during the initial week, with a total of more than 50 different makes of pleasure cars. Of this number, according to present plans at least, 22 companies will be allotted space at the Third Regiment Armory, Broad and Wharton streets, and 21 at the First Regiment's building, Broad and Callowhill streets. In all 35,000 square feet of floor space will be utilized to accommodate applicants and present indications point to close quarters for some of the would-be exhibitors. For example, a nearly equal division of space in each armory was made for the gasoline pleasure cars, the First Regiment structure containing



The Palace Show Poster

16,500 square feet, all of which will be for these cars, while 15,500 square feet will be devoted to the same purpose in the Third Regiment Armory. The latter building is the larger of the two, containing 18,500 square feet, but 3,000 square feet has been set aside for the accessories exhibit, the drawings for which will be conducted next week. As the space is necessarily limited, the demand is expected to far exceed the accommodations for the display of the many little necessary adjuncts to safety and comfort.

The same difficulty, in an aggravated form, confronts the show committee of the Philadelphia Automobile Trade Association regarding the awarding of space for the exhibition of electric and commercial vehicles during the second week, the truck show in particular promising to gobble up all the available space—and more.

The list of exhibitors assigned space and the cars which they handle shows the following: Third Regiment Armory: General Motor Car Co., Lozier; Auto-

mobile Sales Corporation, Peerless & Cadillac; North Philadelphia Automobile Station, Knox; Winton Motor Carriage Co., Winton; Gomery-Schwartz Motor Car Co., Hudson; Oldsmobile Co. of Pennsylvania, Oldsmobile; Packard Motor Car Co., Packard; Paxton-Crumley Automobile Co., Warren-Detroit; L. J. Bergdoll Motor Co., Bergdoll; Automobile Co. of Philadelphia, Marmon; Longstreth Motor Car Co., Alco; Foss-Hughes Motor Car Co., Pierce-Arrow; Stoddard-Dayton Automobile Co., Stoddard-Dayton; Fiat Automobile Co., Fiat; Chalmers-Hipple Motor Co., Chalmers; Chadwick Engineering Works, Chadwick; Pope-Hartford Sales Corporation, Pope-Hartford; The White Co., White; Mitchell-Lewis Motor Co., Mitchell; Abbott-Detroit Motor Co., Abbott-Detroit; A. G. Spalding & Brother, Stevens-Duryea; Johnson Motor Car Co., Haynes.

Those exhibiting at the First Regiment are as follows: Gawthrop & Wister, Elmore; Ford Motor Co., Ford; Hupp Corporation, Philadelphia Branch, R. C. H.; Overland Motor Co., Overland; G. H. Gantert, Stearns and Selden; Tioga Auto Co., National and Hupmobile; Locomobile Co. of American, Locomobile; W. Wayne Davis Co., Everitt; E. C. Johnson Co., Reo and American; Continental Motor Car Co., Henry and Speedwell; Studebaker Bros. Co., Studebaker, E-M-F and Flanders; United Motor Philadelphia Co., Maxwell and Columbia; Motors Distributing Co., KisselKar; D. Walter Harper, Cameron; Oakland Co., of Pennsylvania; Oakland; Thos. B. Jeffery Co., Rambler; Stanley Motor Carriage Co., Stanley; Mercer Automobile Co., Mercer; Cartercar Motor Co., Cartercar; Standard Motor Car Co., Velie; Eldredge Co., Garford.

### Additional Space Necessary at Detroit

DETROIT, MICH., Dec. 11—With over 50,000 square feet of floor space, the Detroit Automobile Show, January 22 to 27, at Wayne Gardens will be one of the largest local shows in this country. Announcement is made at the office of the D. A. D. A., 501 Bowles building, that an annex will be built to extend across Front street and over a large piece of vacant property on the opposite side of the street. This temporary building will be 108 feet wide and 165 feet long, giving 17,820 square feet of floor space. The Wayne Gardens contain 33,180 square feet. The new building will be well heated and brilliantly lighted and the decorations will be on a par with those in the Wayne Gardens.

The city officials were appealed to for permission to build the annex and without any hesitation agreed unanimously, believ-



ing that Detroit should rank with the other cities of the country in its show and that by allowing the closing of Front street they will be giving their assistance in the matter.

The new building will be of single story construction. It will have side windows, giving ample light in the day time. At night it will be brilliantly lighted by electric arc lamps.

Coming, as it does, between the New York shows and the Chicago National Show, Detroit's automobile exhibit holds a strong strategic position in the circuit of American shows. Many Detroit exhibitors who have articles to show are unable to prepare themselves for the opening exhibit at New York and their wares are first seen in the Detroit exhibition. Throughout the country, dealers and agents generally are looking to Detroit for new cars, for new trucks, and for new accessories and, in being able to view a general exhibit in Detroit of the industries of the city and at the same time visit the manufacturers of this city, they find the Detroit show of much practical value.

### Syracuse Show to Follow Boston's

SYRACUSE, N. Y., Dec. 11—In the State Armory the Syracuse Automobile Dealers' Association has been utilizing at its annual winter exhibitions 25,000 square feet of space, besides additional space in adjacent buildings. This question of space has become a serious one, as the association could readily use 50,000 square feet, were that space available. The association is hoping that public-spirited citizens will erect a building ample enough for future purposes of the association and for similar events.

At a meeting of the association held this week the date set for the fourth annual Syracuse Automobile Show was March 12 to 16, inclusive, immediately following the Boston show. Already the whole of the exhibition space has been practically spoken for by dealers, and many must inevitably be disappointed. Special attention will be paid to the decorations and musical program, and, coming as it does immediately following the close of the Boston show, it will be possible to secure many of the special show exhibits sent out by the various manufacturers. A special express train will probably be secured to bring selected Boston exhibits here.

The officers of the association are: C. Arthur Benjamin, Packard representative, president; M. W. Kerr, Everitt, vice-president; John R. Valentine, Chalmers, treasurer; W. R. Marshall, secretary and show manager; directors, Sam Silverman, Jr., Ford; George H. Norris, Cadillac; W. R. Shaw, Reo. The office and headquarters of the association are in the Onondaga Hotel. Mr. Shaw, of the Reo agency, assumed a director's post to replace E. P. Horton, of The United Motors Company, who has removed to Atlanta, Ga.

### Cincinnati Show in Music Hall

CINCINNATI, O., Dec. 11—The Retail Dealers' Association annual show committee reports that applications for space are coming in more rapidly than was expected and that additional features looking to the entertainment of the guests of the association from out of town are now contemplated, including a concert program with vocal selections by artists of national repute. The past shows are to be eclipsed by the event of the week of Washington's birthday and the fact that the association is so fortunate as to have the great Cincinnati Music Hall this year for show purposes has stimulated the committee to make the event one of great social importance as well as an exposition of the progress of the motor world in the central states. Commercial vehicle manufacturers are coming to the front with applications on account of the importance given this class of automobiles by the dealers' committee in arranging special show dates following the pleasure vehicle show and many more types of this class of cars will be shown here this year than ever before.

The Cincinnati show management will, as usual, give much attention to the setting of displays and has secured the highest

authority obtainable as regard the artistic and floral features of the coming show.

### Canadian National Shows Progressing

Judging by the applications received, great interest is being shown by manufacturers of automobiles in the two Canadian national automobile shows to be held in Montreal and Toronto, on dates February 3 to 10, and February 21 to 28, respectively.

Manager E. M. Wilcox, 123 Bay St., Toronto, states that almost every American car seems to be now represented in Canada, and there will undoubtedly be a large increase in the exports of automobiles from the United States to Canada in 1912, although the increase last year was almost double that of the year before. The Armory has been secured from the Dominion Government for the Toronto show and the Drill Hall for the Montreal show.

### International Rubber Show in 1912

Sir Henry Blake, G. C. M. G., will act as presiding officer of the first International Rubber Exposition to be held in the United States and which is scheduled for September, 1912. Practically every important rubber industry in the world will be represented and the scope of the exposition may be judged from the fact that over seventy leading men connected with various branches of the industry in foreign lands have accepted committee assignments for important work before and during the exposition. The show will be staged in the new Grand Central Palace under the management of the International Exposition Co. of which Samuel A. Miles is a director.

### Atlanta May Promote a Show

ATLANTA, GA., Dec. 9—The Atlanta Automobile and Accessory Association has started two campaigns which should result in the organization of a state association of automobilists and a dealers' show in Atlanta.

A series of meetings has been held with a view of working up interest in the much-needed state association. The most recent one was on Monday, December 11.

Committees are now working through the field to find out the prospects for a successful dealers' show. Atlanta has an ideal place for such an exhibition in the Auditorium-Armory, where the first Southern show under national auspices was held.

### M. and A. M. Show Week Meetings

In connection with the activities of the show season next January the Motor and Accessory Manufacturers have announced the following meetings: Executive Committee, Tuesday, January 9, at 10 a. m., at the association's offices, 17 West Forty-second street; Board of Directors, same day and place at 11 a. m.; Banquet Committee, immediately following that of the Board of Directors; ninth annual meeting, Wednesday, January 10 at 10.30 a. m., at the Waldorf-Astoria; annual banquet, grand ballroom, Waldorf-Astoria, Thursday, January 11, at 7 p. m.

### Rochester Space All Disposed Of

ROCHESTER, N. Y., Dec. 11—The annual show of the Rochester Automobile Dealers' Association, will this year for the first time be held in the State Armory, one of the largest exhibition display spaces in the State.

The committee in charge is as follows: F. W. Peck, chairman; J. C. Dryer, secretary; W. C. Barry, Jr., A. F. Crittenden, C. E. Hartson, A. R. McKenney, S. C. Babcock, F. R. Luescher, C. E. Sager, G. F. Bauer, Arthur McNall, A. V. Hart and D. F. Garber. Colonel C. A. Simmons, assistant adjutant-general of the state, who managed Rochester's show two years ago, will be in charge.

# Exhibitors' List

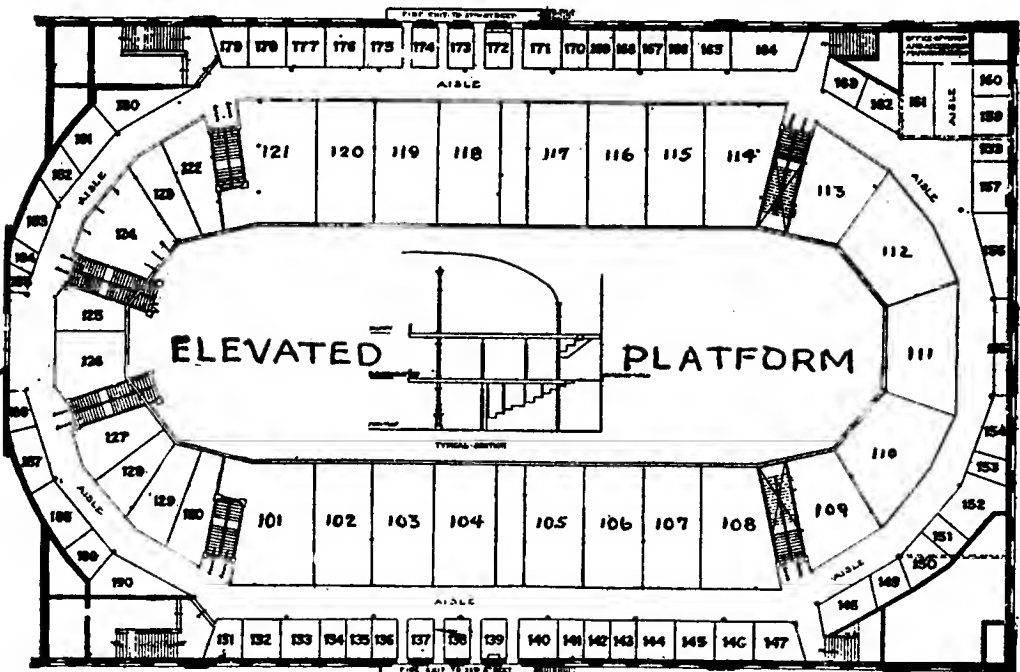
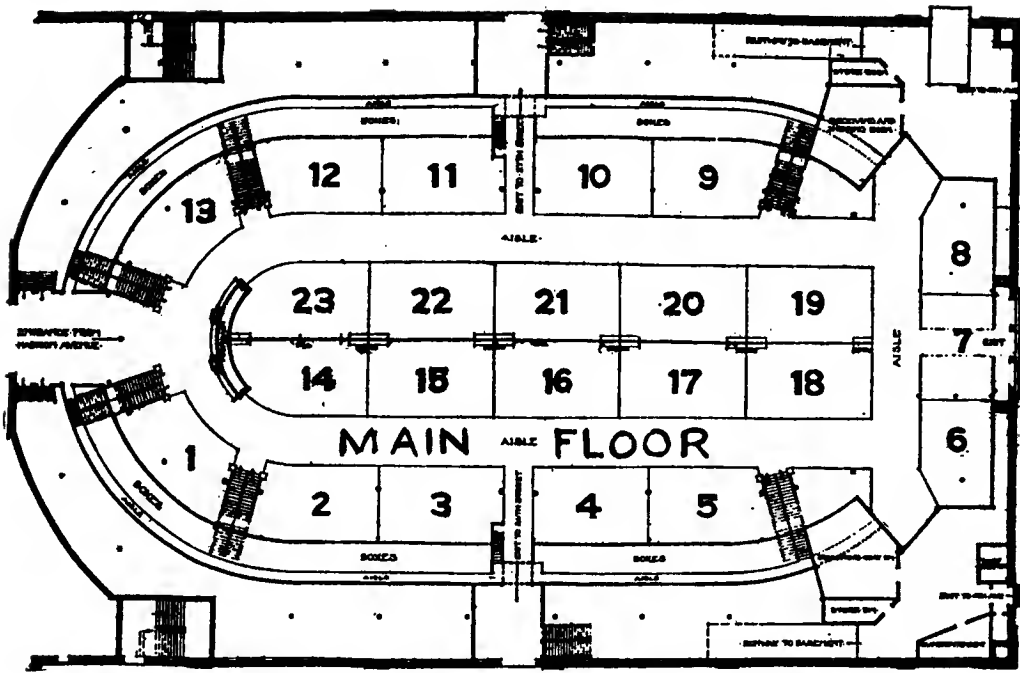

- Space No. 249 Benford Mfg. Co.
- \*402 Best Ignition Equip. Co.
- \*533 John W. Blackledge Mfg. Co.
- \*292 Booth Demountable Rim Co.
- 218 Bosch Magneto Company.
- 253 Bower Roller Bearing Co.
- 190 S. F. Bowser & Co., Inc.
- \*261 Briggs & Stratton Co.
- 186 Briscoe Mfg. Co.
- \*611 Brown Co.
- 169 Brown-Lipe Gear Co.
- 255 Buda Company.
- 174 Byrne Kingston & Co.
- \*607 Calmon, Asbestos & Rubber Works.
- 544 Carnegie Steel Co.
- \*531 F. S. Carr Co.
- 244 Champion Ignition Co.
- 184 The Chandler Co.
- 241 Chicago Telephone Co.
- 600 Chilton Co.
- 546 Class Journal Co. (Automobile).
- 545 Class Journal Co. (Motor Age).
- \*605 Clucker & Hixson Co.
- \*563 C. M. B. Wrench Co.
- 155 Coes Wrench Co.
- 217 Columbia Lubricants Co.
- 185 Columbia Nut & Bolt Co., Inc.
- 154 Conn. Tel. & Electric Co.
- 152 Consolidated Rub. Tire Co.
- \*277 Continental Rubber Works.
- \*266 Adam Cooks Sons.
- 220 Covent Motor Vehicle Co.
- \*265 C. Cowles & Co.
- \*510 Cox Brass Mfg. Co.
- 187 Wm. Cramp & Sons Ship & Eng. Bldg. Co.
- 592 C. J. Cross & Co.
- \*572 Frank H. Cross Co.
- 240 Crucible Steel Co. of Amer.
- \*569 Smalley Daniels.
- \*516 The Dayton Engineering Laboratories Co.
- 243 The Dean Electric Co.
- 313 A Detroit Elec. Appliance Co.
- 250 Detroit Lubricator Co.
- 138 Diamond Chain & Mfg. Co.
- 127 Diamond Rubber Co.
- 182 Joseph Dixon Crucible Co.
- \*310 Doebler Die Casting Co.
- \*608 Donnelly Motor Equip. Co.
- 233 Dorian Remountable Rim Co.
- \*287 Dover Stamping & Mfg. Co.
- \*317 Double-Fabric Tire Co.
- 260 Driggs-Seabury Ordnance Corp.
- \*404 Duplex Magneto & Spark Plug Co.
- \*606 John L. G. Dykes Co.
- \*248 The Eagle Co.
- 602 J. Eavenson & Sons, Inc.
- 237 Edison Storage Battery Co.
- 181 The Edmunds & Jones Co.
- 216 Eisemann Magneto Co.
- \*578 El Arco Radiator Co.
- 183 Electric Storage Battery Co.
- \*576 H. A. Elliott.
- \*413 Endurance Tire & Rub. Co.
- 159 English & Meraick Co.
- \*518 Essex Rubber Co., Inc.
- \*304 Esterline Company.
- \*417 E. Z. Way Motor Grease Co.
- \*515 Fedders Mfg. Co.
- 222 Federal Rubber Mfg. Co.
- 559 Findeisen & Kropf Mfg. Co.
- 164 Firestone Tire & Rub. Co.
- 122 The Fisk Rubber Co.
- 406 L. V. Flechter & Co.
- \*609 Ernst Flentje.
- \*589 H. H. Franklin Mfg. Co. (Die Casting Department).
- 540 Peter A. Frasse & Co.
- \*274 Gabriel Horn Mfg. Co.
- 604 Garage Equipment Mfg. Co.
- \*529 Gardner Engine Starter Co.
- \*612 Geisler Bros. Stge. Bat. Co.
- 307 Gemmer Mfg. Company.
- 320 General Electric Company.
- 501 James L. Gibney & Bro.
- \*273 The Gilbert Mfg. Co.
- 561 M. S. Gilmer.
- \*271 The Globe Machine & Stamping Co.
- 126 The B. F. Goodrich Co.
- 130 Goodyear Tire & Rubber Co.
- 427 Gould Storage Battery Co.
- 129 Gray & Davis.
- \*267 Gray-Hawley Mfg. Co.
- \*524 The Gray Specialty Co.
- \*626 Emil Grossman Company.
- \*564 The Hall-Thompson Co.
- \*525 Hardman Tire & Rubber Co.

- PLEASURE VEHICLES.**
- Space No. 103 American Locomotive Co.
  - 106 American Motors Co.
  - 214 Anderson Electric Car Co
  - 207 Atlas Motor Car Co.
  - 213 Baker Motor Vehicle Co.
  - 112 Brush Runabout Co.
  - 14 Buick Motor Co.
  - 16 Cadillac Motor Car Co.
  - 55 Cartercar Co.
  - 21 Chalmers Motor Co.
  - 110 Columbia Motor Car Co.
  - 117 Corbin Motor Vehicle Corp
  - 3 Dayton Motor Car Co.
  - 105 Elmore Mfg. Co.
  - 23 E. M. F. Company.
  - 212 Flanders Mfg. Co.
  - 8 Franklin Mfg. Co., H. H.
  - 201 The Garford Co.
  - 114 Haynes Automobile Co.
  - 20 Hudson Motor Car Co.
  - 50 Inter-State Automobile Co.
  - 111 Jackson Automobile Co.
  - 121 Knox Automobile Co.
  - 10 Locomobile Co. of America.
  - 7 Lozier Motor Co.
  - 208 W. H. McIntyre Co.
  - 204 Marquette Motor Co.
  - 120 Matheson Automobile Co.
  - 18 Maxwell-Briscoe Motor Co.

- Space No.**
- 52 Mercer Automobile Co.
  - 104 Metzger Motor Car Co.
  - 12 Mitchell-Lewis Motor Co.
  - 107 Moline Automobile Co.
  - 118 Moon Motor Car Co.
  - 119 National Motor Vehicle Co.
  - 101 Nordyke & Marmon Co.
  - 4 Oakland Motor Car Co.
  - 202 Ohio Motor Car Co.
  - 1 Olds Motor Works.
  - 17 Packard Motor Car Co.
  - 205 Palmer & Singer Mfg. Co.
  - 11 Peerless Motor Car Co.
  - 19 Pierce-Arrow Motor Car Co.
  - 54 Pierce Motor Co.
  - 5 Pope Mfg. Co.
  - 108 Premier Motor Mfg. Co.
  - 116 Pullman Motor Car Co.
  - 22 Reo Motor Car Co.
  - 109 Selden Motor Vehicle Co.
  - 209 S. G. V. Co.
  - 53 Simplex Automobile Co.
  - 51 Simplex Motor Car Co.
  - 203 Speedwell Motor Car Co.
  - 6 F. B. Stearns Co.
  - 13 Stevens-Duryea Co.
  - 102 E. R. Thomas Motor Car Co.
  - 215 The Waverly Co.
  - 2 The White Company.
  - 15 Willys-Overland Co.
  - 9 Winton Motor Carriage Co

- ACCESSORIES.**
- Space No. 157 Ajax-Grieb Rubber Co.
  - \*603 Ajax Trunk & Sample Case Co.
  - \*526 The J. Alexander Mfg. Co.
  - \*314 Allen Auto Specialty Co.
  - \*178 American Ball Bearing Co.
  - \*503 The American Bronze Co.
  - \*258 American Circular Loom Co.
  - 506 American Oil Pump & Tank Co.
  - \*519 American Rim Co.
  - 423 American Taximeter Co.
  - 541 American Vanadium Co.
  - 502 The Aristos Co.
  - 551 James R. Ashley.
  - 566 Atlas Chain Company.
  - 140 Atwater Kent Mfg. Wks.
  - \*281 Auburn Auto Pump Co.
  - 594 Automobile Journal Pub. Co.
  - \*422 Auto Specialty Co.
  - 245 Automobile Supply Mfg. Co.
  - \*573 Auto Wind Shield Co.
  - \*595 The A-Z Co.
  - 125 The Badger Brass Mfg. Co.
  - 136 Baldwin Chain & Mfg. Co.
  - 586 Bantam Anti-Friction Co.
  - 555 C. B. Barker & Co., Ltd.
  - 587 Barthel, Daly & Miller.
  - \*309 Batavia Rubber Co.
  - \*577 Baum's Castorine Co.

\* Indicatea will exhibit in Part I only; \*\* in Part II only. No asterisk indicates will exhibit in Parts I and II.

at Garden Show

- Space No.
- \*528 F. A. Hardy & Co.
- 134 R. E. Hardy Co.
- 162 A. W. Harris Oil Co.
- 220A Harrison Radiator Co.
- 160 Hartford Mech. Screw Co.
- 156 Hartford Suspension Co.
- 232 Havoline Oil Co.
- \*282 George A. Haws.
- \*579 Hawthorne Mfg. Co.
- \*219 Hayes Manufacturing Co.
- \*270 Heinz Electric Co.
- \*259 Herz & Co.
- 305 Hess-Bright Mfg. Co.
- \*302 Hess Spring & Axle Co.
- \*262 Hodgman Rubber Company.
- 189 Hoffecker Co.
- 588 S. Hoffnung & Co., Ltd.
- \*622 R. M. Hollingshead Co.
- 601 Homo Company of America.
- 597 Horseless Age Co.
- 418 H. J. Houpert.
- 131 Hyatt Roller Bearing Co.
- \*509 Hydraulic Oil Storage Co.
- \*575 Ideal Wind Shield Co.
- 549 Ignition Co.
- 558 Imperial Bearing Co.
- 257 International Acheson Graphite Co.
- \*513 Internat. Metal Polish Co.
- \*318 Jackson Church Wilcox Co.
- 252 Jacobson Brandow Co.
- 173 Janney, Steinmetz & Co.
- \*567 Jeffery-Dewitt Co.
- 547 J. M. Shock Absorber Co.
- 284 Isaac G. Johnson & Co.
- 137 Pbineas Jones & Co.
- 143 Jones Speedometer.
- \*291 Kellogg Mfg. Co.
- \*564 W. J. Kells Mfg. Co.
- 598 Keystone Lubricating Co.
- \*613 K. W. Ignition Co.
- \*428 Wm. R. Laidlaw, Jr.
- 231 Leather Tire Goods Co.
- 225 Lee Tire & Rubber Co.
- 590 Lefever Arms Co.
- 133 Light Mfg. & Foundry Co.
- 229 Link Belt Company.
- 226 Lovell-McConnell Mfg. Co.
- 151 McCord Mfg. Company.
- \*280 McCue Company.
- 552 F. T. McGinnis.
- \*276 Manufacturers Foundry Co.
- 537 Marburg Brothers, Inc.
- 553 The Mead Engine Company.
- 548 Merchant & Evans & Co.
- \*421 Metal Stamping Co.
- \*520 Meteor Auto Tank Co.
- 135 C. A. Mezger, Inc.
- 228 Michelin Tire Company.
- 161 Chas. E. Miller.
- \*618 Wm. P. Miller's Sons.
- 562 Modern Auto Appliance Co.
- \*565 Morrison-Ricker Mfg. Co.
- 180 A. R. Mosler & Co.
- \*581 Frank Mossberg Co.
- 556 Motor.
- \*617 Motor Car Equipment Co.
- 560 Motor Vehicle Pub. Co.
- 505 Motor World Publishing Co.
- 234 Motz Tire & Rubber Co.
- 239 Muncie Gear Works.
- \*616 L. J. Mutty Co.
- 598A Mutual Auto Accessories Co.
- 411 Narragansett Chemical Co.
- \*415 Geo. Nash Co.
- \*621 Nathan Novelty Mfg. Co.
- 132 National Carbon Co.
- \*263 National Coil Co.
- \*242 National Rubber Co.
- 139 National Tube Co.
- 223 New Departure Mfg. Co.
- \*426 N. J. Car Spring & Rub. Co.
- 539 Newmastic Tire Co.
- 591 The New Miller Mfg. Co.
- \*624 New York Coil Co.
- 141 N. Y. & N. J. Lub. Co.
- 251 New York Spg. Goods Co.
- 561 New York U-Ray Sales Co.
- 585 Niagara Lead & Battery Co.
- \*278 Noera Manufacturing Co.
- \*514. A. S. Noonon Tool & Mach. Works.
- \*517 North East Electric Co.
- \*319 Northway Motor & Mfg. Co.
- 172 Oliver Mfg. Co.
- \*221 Pantasote Co.
- 416 Paragon Auto Parts Mfg. Co.
- 147 Pennsylvania Rubber Co.
- 542 The Perfection Spring Co.
- 403 Perfect Window Reg. Co.
- \*565 Philadelphia Steg. Bat. Co.
- \*316 G. Piel Company.
- 167 Pittsfield Spark Coil Co.
- \*568 Polson Manufacturing Co.
- \*556 Power Wagon Pub. Co.
- \*570 Prince Tire Co.
- 599 Thos. Prosser & Son.
- 146 Remy Electric Co.

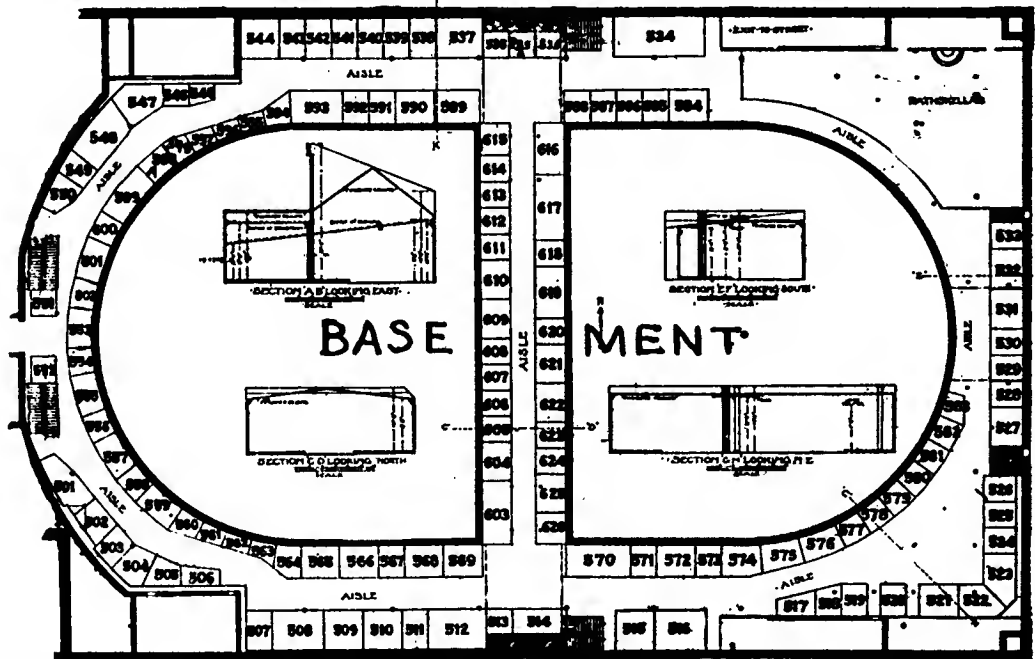
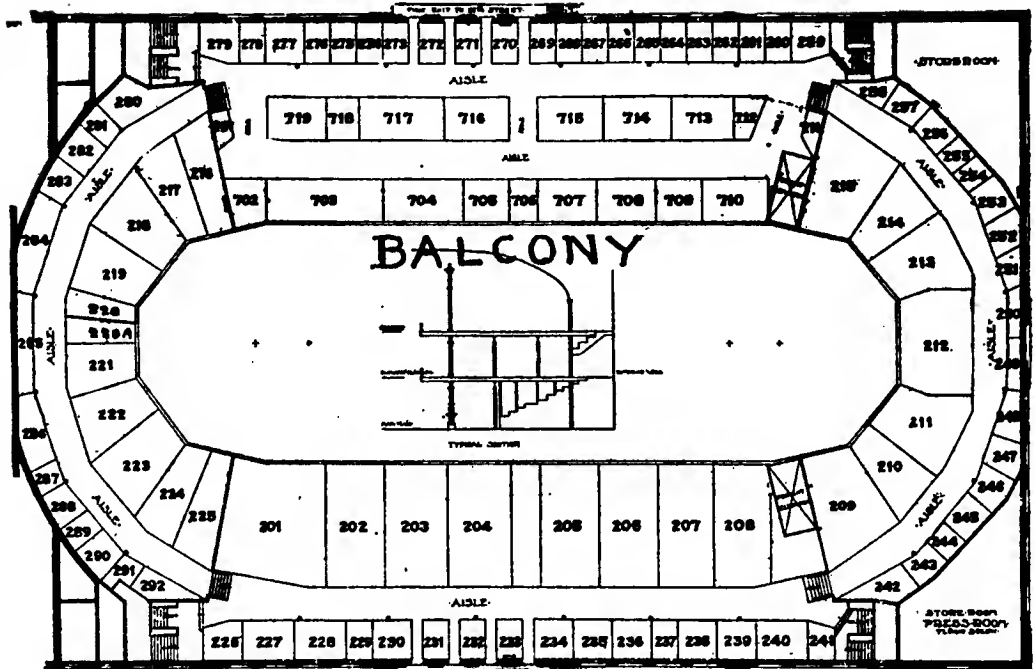

- Space No.
- 148 Republic Rubber Co.
- 543 Rhineland Mch. Works Co.
- \*424 P. Rielly & Son.
- \*623 Riley-Klotz Mfg. Co.
- \*615 R. I. V. Co.
- \*279 Rose Manufacturing Co.
- \*314 Ross Gear & Tool Co.
- 238 Royal Equipment Co.
- \*285 Rushmore Dynamo Works.
- 290 Russian Tire Co.
- \*269 J. H. Sager Co.
- 535 S. & S. Shock Absorber Co.
- \*614 S. B. R. Specialty Co.
- \*275 Seamless Rubber Co.
- \*264 C. A. Shaler Co.
- \*512 Shawmut Tire Co.
- 534 Sheldon Axle Co.
- 557 Simonds Mfg. Co.
- 504 S. K. F. Ball Bearing Co.
- 149 A. O. Smith Co.
- \*429 Grant E. Smith.
- 535A Smith Gasoline Meter Co.
- 554 Sonora Motor Horn Co.
- \*521 L. Sonneborn Sons, Inc.
- \*312 F. W. Spacke Machine Co.
- 308 Sparks-Withington Co.
- \*584 Sphink Motor Co.
- 168 Spicer Mfg. Co.
- 128 C. F. Splittorf.
- \*301 Sprague Umbrella Co.
- \*224 Springfield Metal Body Co.
- 163 Standard Roller Bearing Co.
- 247 Standard Thermometer Co.

- Space No.
- \*582 Standard Tire & Rubber Co.
- \*527 Standard Tire Protector Co.
- 177 Standard Welding Co.
- \*583 John T. Stanley.
- \*405 Star Speedometer Co.
- 306 Start-Lite Co.
- \*571 Culver Stearns Mfg. Co.
- \*286 Stein Double Cushion Tire Co.
- \*619 Stevens & Co.
- 227 Stewart & Clark Mfg. Co.
- 235 Stromberg Mot. Devices Co.
- 254 Stutz Auto Parts Co.
- 171 Swinehart Tire & Rub. Co.
- 246 Texas Company.
- 538 And. C. Thompson Auto Co.
- 166 Timken Detroit Axle Co.
- 165 Timken Roller Bearing Co.
- \*407 Chas. O. Tingley & Co.
- \*\*313 Torbenson Gear and Axle Co.
- 536 Joseph Tracy.
- 230 Treadwell Engineering Co.
- \*508 Troy Carriage Sun Shade Co.
- \*620 Tryon Auto Pump Co.
- \*511 Chas. H. Tucker Co.
- \*523 Tucker Tool & Machine Co.
- 158 Turner Brass Works.
- \*414 Typhoon Signal Co.
- \*610 Union Auto Specialties Co.
- 315 United Rim Co.
- 532 U. S. Auto Horn Co.
- 144 U. S. Light & Heat Co.

- Space No.
- 124 United States Tire Co.
- \*507 United Steel Co.
- \*309 United Steel Co.
- 188 Vacuum Oil Co.
- \*272 Valentine & Company.
- 311 Vanadium Metals Company.
- 409 Van Auken Indicator Co.
- \*625 Vanguard Mfg. Co.
- 123 Veeder Mfg. Co.
- \*412 Velox Polish Mfg. Co.
- \*268 Vesta Accumulator Co.
- \*303 Voorbees Rubber Mfg. Co.
- \*580 Warburg Rim Co.
- \*574 Ward Leonard Elect. Co.
- 176 Warner Gear Co.
- 150 Warner Instrument Co.
- 236 Warner Mfg. Co.
- 430 Wasson Piston Ring Co.
- 550 Wayne Oil Tank & Pump Co.
- 142 Weed Chain Tire Grip Co.
- \*530 Westen Mfg. Co.
- 170 Weston Mott Co.
- \*289 Western Tool & Forge Co.
- 145 Wheeler & Seebler.
- \*288 White & Bagley Co.
- 179 The Whitney Mfg. Co.
- \*283 Willard Storage Battery Co.
- \*420 C. A. Willey Co.
- 175 J. H. Williams & Co.
- \*425 Wm. R. Winn.
- \*313 Wolverine Lubricants Co.
- 153 O. W. Young.

\* Indicates will exhibit in Part I only; \*\* in Part II only. No asterisk indicates will exhibit in Parts I and II.

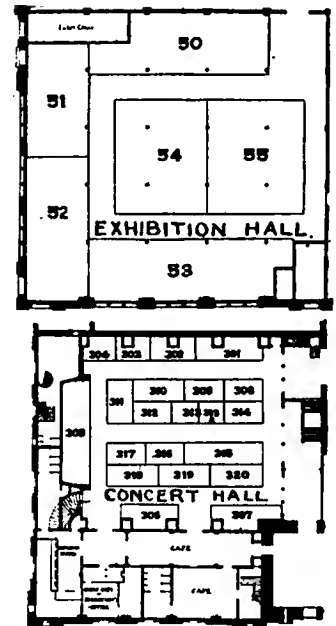
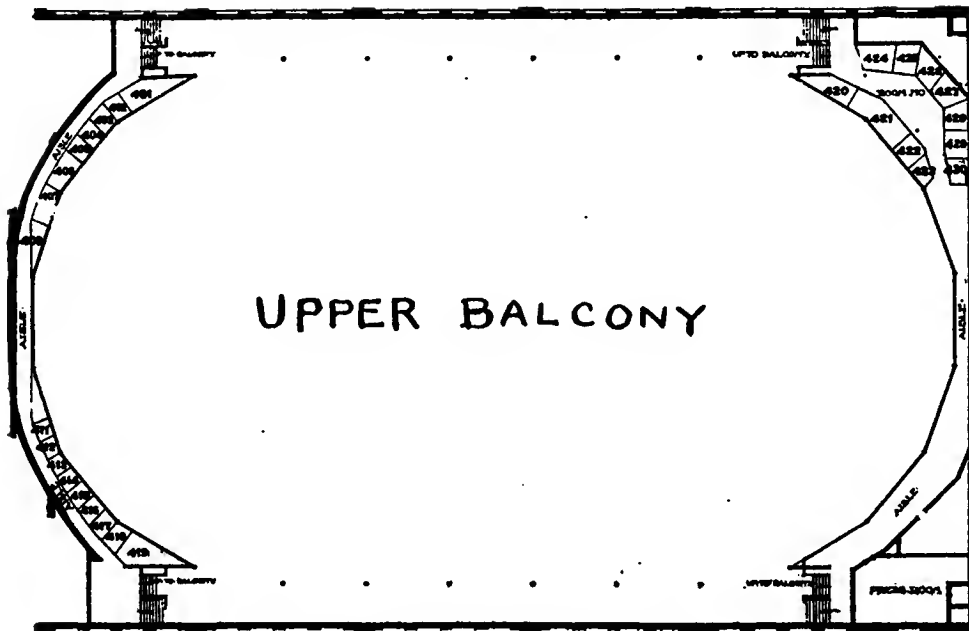

Showing arrangement of spaces in Madison Square Garden, upper balcony, Exhibition Hall and Concert Hall

News of Other Local Shows

MILWAUKEE, Wis., Dec. 11—The opening night of the fourth annual Milwaukee automobile show under the auspices of the Milwaukee Automobile Dealers' Association in the Auditorium from January 13 to 19, inclusive, will be Milwaukee Automobile Club Night and the 600 members of the club will be the special guests of the dealers. Sunday, January 14, will be Owners' Day; January 15, Interurban Day; January 17, Merchants' and Manufacturers' Day, on which commercial vehicles will be featured; January 18, Wisconsin Automobile Dealers' and Wisconsin State Automobile Association Day, and the closing day, January 19, will be Society Day. The motor club, which conducted the first two Milwaukee shows, is co-operating with the Dealers' Association to make the fourth show a huge success.

LOUISVILLE, Ky., Dec. 11—The fifth annual exhibition of the Louisville Automobile Dealers' Association will be held February 21, 22, 23 and 24 in the First Regiment Armory, which covers more floor space, it is said, than any other building in the South. The 1912 show is scheduled a month earlier than it

was held last year. The committees in charge of the exhibition in 1911 did their work so well that they have again been chosen to make arrangements for the coming show, and look after all the details connected with the displays.

TIFFIN, O., Dec. 11—The dates for the second annual Advertiser Auto Show, under the auspices of a local organization have been definitely fixed for March 6 to 9 inclusive. Space is now available.

Prof. Warren S. Johnson Dead

MILWAUKEE, Wis., Dec. 11—Prof. Warren S. Johnson, president and treasurer of the Johnson Service Co., one of the largest builders of pleasure and commercial cars at Milwaukee, Wis., who died at Los Angeles, Cal., on December 5, after an illness of two years, was a noted inventor and designer and probably the first man to propose and execute the idea of using the motor vehicle in the postal service.

The funeral was held at Los Angeles on December 7 and the remains were cremated, at Prof. Johnson's request.

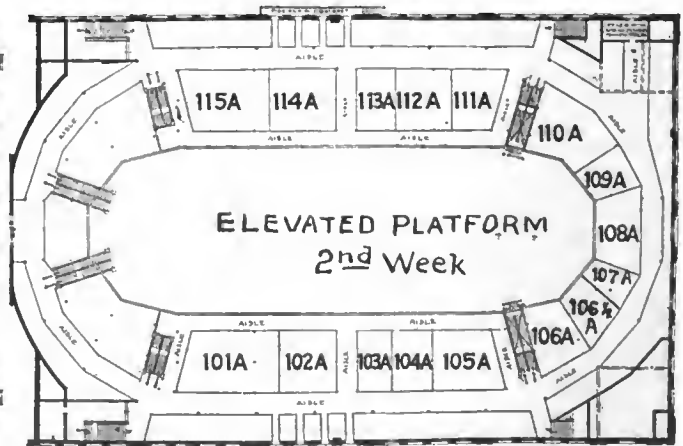
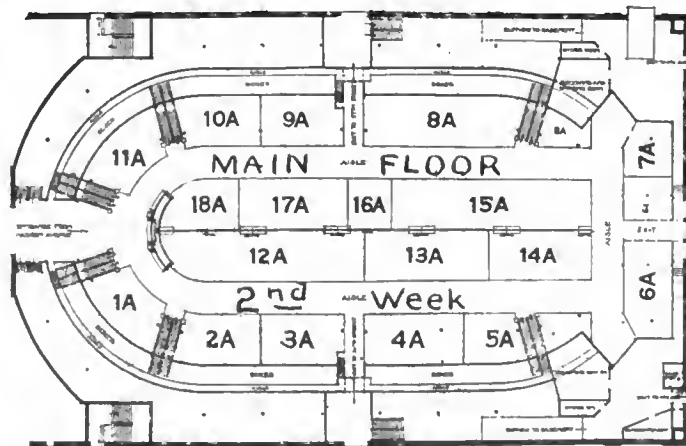

How the commercial exhibitors at the Garden will be installed during the second week of the show

- Space No.
- 11A American Locomotive Co.
- 106A Anderson Electric Car Co.
- 6A The Autocar Company.
- 109A Baker Motor Vehicle Co.
- 106 1/2 A Bronx Electric Vehicle Co.
- 103A Brush Runabout Co.
- 114A Buick Motor Co.
- 104A Cartecar Co.

- Space No.
- 4A The Garford Co.
- 8A General Motors Truck Co.
- 110A General Motors Truck Co.
- 111A General Vehicle Co.
- 115A General Vehicle Co.
- 10A Grabowsky Power Wag. Co.
- 1A Knox Automobile Co.
- 3A Locomobile Co. of America.

- Space No.
- 16A Lozier Motor Co.
- 102A W. H. McIntyre Co.
- 15A Mack Bros. Motor Car Co.
- 14A Metzger Motor Car Co.
- 105A Morgan Motor Truck Co.
- 12A Packard Motor Car Co.
- 9A Peerless Motor Car Co.
- 2A Pierce-Arrow Motor Car Co.

- Space No.
- 18A Pope Mfg. Co.
- 113A Reo Motor Car Co.
- 17A Alden Sampson Mfg. Co.
- 5A Speedwell Motor Car Co.
- 7A F. B. Stearns Co.
- 101A Studebaker Automobile Co.
- 107A Ward Motor Vehicle Co.
- 13A The White Company.

# Late General and Trade News

**A**TLANTA, GA., Dec. 7—The awards in the Tour Around Georgia, which virtually ended in Atlanta, December 2, have just been made public. The reason for the delay was the fact that while most of the cars finished in Atlanta a few machines which joined the tour on the first, second and third days of the run had to go back to their starting points before they completed the circuit and no awards could be made until all had finished and until all the checkers' reports had been mailed to the referee.

The two special prizes offered for consistent running and for sticking most closely to the time card were awarded by Referee Connally. First prize was given to the Velie roadster, entered from the Atlanta Velie branch, while the second prize went to the Flanders team. The hard luck cup, offered by the Atlanta Ad-Men's Club, had previously been awarded, on a vote of the contestants, to W. G. Southerlin whose Overland was continually in hot water.

The other prize winners, the entrant and the amount of prize money received follow:

**Class A (Cars Costing \$2,500 and Over)**

No. 3—Dr. J. C. Luke, Ocils, Ga., Ohio.....	\$108.33
No. 15—T. C. Lauren, Atlanta, Packard.....	108.33
No. 21—Frank G. Corker, Dublin, Ga., White Gas.....	108.33
No. 23—Ralph Walker, Atlanta, National.....	108.33
No. 37—Evelyn Harris, Atlanta, Thomas Flyer.....	108.33
No. 53—Muchalu Cigar Co., Americus, Ga., Marmon.....	108.33

**Class B (Cars Costing \$1,600 to \$2,500)**

No. 1—Atlanta Ad Men's Club, Imperial.....	\$50
No. 2—Ohio Motor Car Co., Cincinnati, Ohio.....	50
No. 5—Jake W. Paulk, Ocilla, Ga., Ohio.....	50
No. 11—Atlanta Chamber of Commerce, Cole 30-40.....	50
No. 19—Velie Motor Vehicle Co., Atlanta, Velie.....	50
No. 22—Sam Bashlinski, Dublin, Ga., Chalmers.....	50
No. 28—U. S. Fuller, Culloden, Ga., Cadillac.....	50
No. 31—W. A. Ayash, Americus, Ga., Overland.....	50
No. 36—G. W. Varn, Valdosta, Ga., Cadillac.....	50
No. 40—F. G. Edwards, Albany, Ga., Chalmers.....	50
No. 43—W. B. Cummings, Atlanta, Buick.....	50
No. 46—Gulf Refining Co., Atlanta, Mitchell.....	50
No. 60—B. T. Bowers, Cannon, Ga., Case.....	50

**Class C (Cars Costing from \$1,000 to \$1,600)**

No. 6—W. E. Sawyer, Americus, Ga., Overland.....	\$130
No. 14—Miss Regina E. Rambo, Marietta, Ga., Overland.....	130
No. 30—Holmes Bros., Culloden, Ga., Buick.....	130
No. 42—Steve R. Johnaton, Atlanta, Buick.....	130
No. 56—Trio Laundry, E. H. Wilson, Atlanta, E.M.F.....	130

**Class D (Cars Costing \$1,000 or Less)**

No. 33—E.M.F. Company, Atlanta, G. W. Hanoon, Manager, Flanders.....	\$162.50
No. 34—E.M.F. Company, Atlanta, G. W. Hanoon, Manager, Flanders.....	162.50
No. 35—E.M.F. Company, Atlanta, G. W. Hanoon, Manager, Flanders.....	162.50
No. 48—Georgia Motor Car Company, Atlanta, Liberty Brush.....	162.50

## Traction Company Selling Electric Cars

A new era in motor car selling in Milwaukee, Wis., began on December 1, when the Milwaukee Electric Railway & Light Co., one of the largest and strongest public service corporations in the United States, became selling agent for the Rauch & Lang electric cars. The former agent was the Welch Bros. Motor Car Co., which has sold its Packard business to the Packard Motor Car Co., of Chicago, to enable the Welch brothers to care for their late father's vast estate. The Electric Company, as the M. E. R. & L. Co. is generally known, has as territory the city of Milwaukee, Kenosha, Racine, East Troy, Burlington, Waukesha, Oconomowoc, Watertown and all points reached by its interurban lines, in addition to the contiguous territory. John I. Beggs, former president and general manager of the company and mainly responsible for its remarkable growth and prosperity, purchased a Rauch & Lang electric several years ago, after an extensive study of electric cars, and several of these cars are now used by officials and superintendents of the traction company. Recently the new management of the Electric Com-

pany established a large private garage for its numerous light and heavy trucks, including gasoline and electric cars, used for transportation and repairs. The sales department is at the Public Service building, the \$2,000,000 terminal of the traction company, and the show rooms at the M. E. R. & L. Co. garage, 451-453 Broadway.

## Bay State Association's Annual Banquet

**BOSTON, Dec. 11**—The annual banquet of the Bay State Automobile Association at the Hotel Somerset this evening was the most successful motor affair of a social nature that has ever taken place in Boston. There were about 250 members and guests present.

At the head table President E. A. Gilmore had the center position and on either side of him were the following guests: Mayor John F. Fitzgerald, of Boston, President George W. Smith, of the Boston Chamber of Commerce, President George A. Coleman, of the Associated Advertising Clubs of America, Ex-Chairman Harold D. Parker, of the Massachusetts Highway Commission, Col. William D. Sohler and Frank D. Kemp, of the Highway Commission, President Lewis R. Spare, of the Massachusetts State Automobile Association, former president of the A. A. A., President John H. MacAlman, of the Boston Automobile Dealers' Association; President C. F. Whitney, of the Boston Commercial Vehicle Dealers Association, Chairman A. G. Batchelder, of the American Automobile Association executive committee, President Alvin E. Bliss, of the Malden Automobile Club, President A. E. Converse, of the Winchendon Automobile Club, President W. H. Chase, of the Leominster Automobile Club, President William N. Appleton, of the Haverhill Automobile Club, President John S. Harrington, of the Worcester Automobile Club and Secretary James Fortesque, of the Massachusetts State A. A., and many others prominent in automobile circles.

President George W. Smith, of the Boston Chamber of Commerce, and President George A. Coleman, of the Associated Advertising Clubs of America were among the speakers of the evening. President Hugh Chalmers, of the Chalmers Motor Car Company, was to have delivered his address upon "Salesmanship," but was prevented by a sudden illness.

## Quaker Dealers Elect New Officers

**PHILADELPHIA, Dec. 8**—At the annual meeting and election of the Philadelphia Automobile Trade Association on Wednesday at the organization's headquarters, southwest corner of Broad and Callowhill streets, the following officers were elected for the ensuing year:

Louis C. Block, manager of the Philadelphia branch of the Ford Motor Company, president; William P. Herbert, of the General Motor Car Company, handling the Lozier car, vice-president, and F. W. Eveland, of the A. G. Spalding & Brother Company, agents for the Stevens-Duryea, re-elected treasurer.

R. M. Cook, manager of the Automobile Sales Corporation (Peerless and Cadillac), and H. H. Coale, sales manager of the Autocar Company, were elected members of the Board of Directors, while W. Wayne Davis, head of the W. Wayne Davis Company (Everitt), and J. C. Bartlett, of the Woods Electric Company, were chosen members of the Committee on Admissions.

All of the new officers of the association are well and favorably known in automobile trade circles, not only in Philadelphia, but throughout the East.



# A Jaunt Through South Carolina,

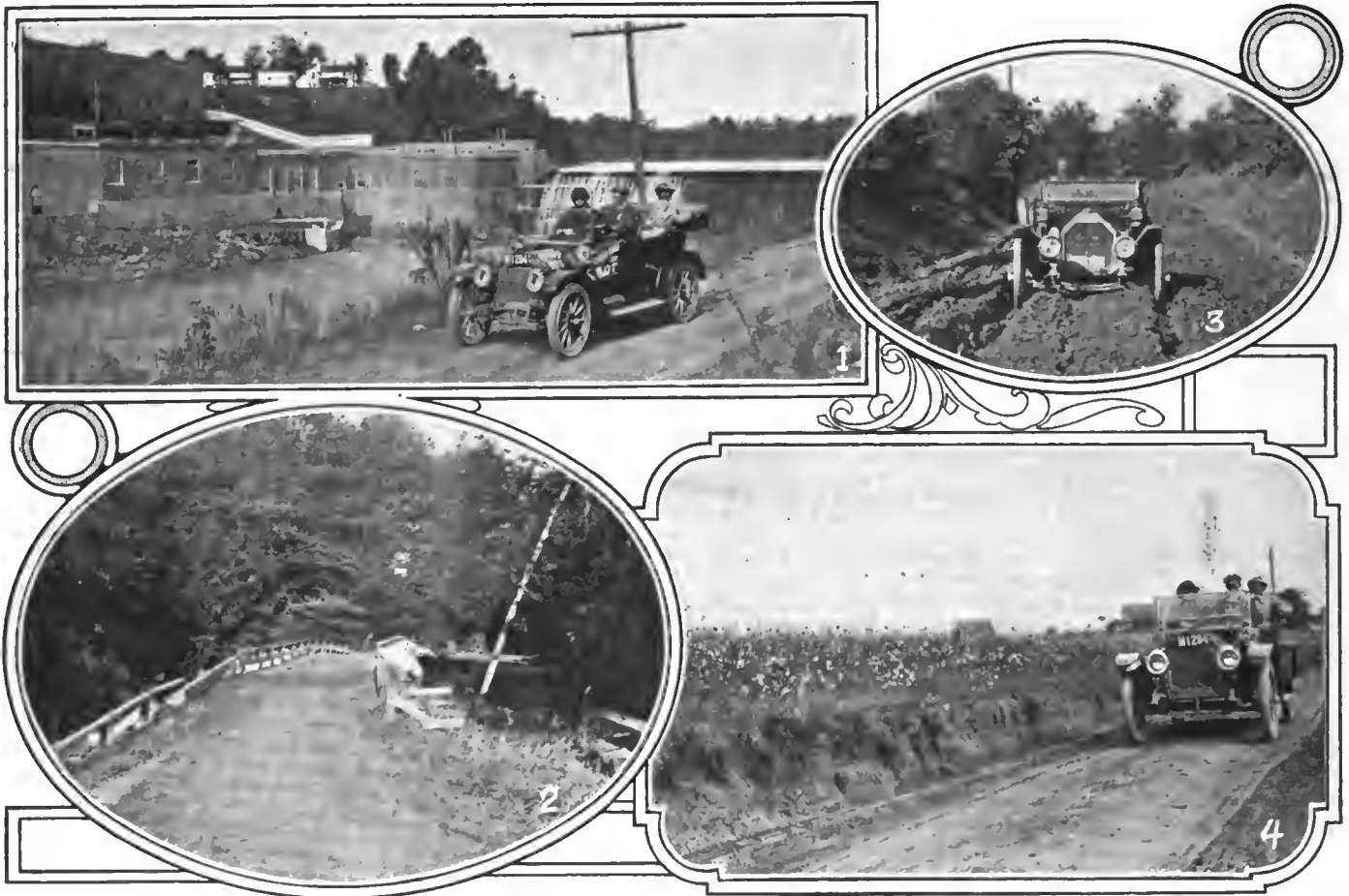

1—Where the Pacolet River is harnessed to turn the cotton mills at Converse  
2—Bridge building is no fine art here, but is needed only occasionally

3—The worst spot found in South Carolina and not so very bad after all  
4—In the heart of Cotton's kingdom, 7 miles from Greenville

WHEN the Glidden Tour crossed South Carolina a road had been selected for the caravan to follow that touched only the extreme western portion of the state. The topography of South Carolina is level generally, and the nearer one approaches the Atlantic seaboard the flatter and more swampy it is.

Within the state the highway followed was 134.3 miles long, all of which is more or less improved. The country raises cotton as a staple and corn, turpentine and lumber incidentally. The scenery lacks the grandeur of the Virginia hills, but the roads are an improvement over those of the section south of Roanoke.

There was a bumper cotton crop produced in South Carolina this season and part of it was marketed at good prices. However, a majority of the farmers and local dealers and ginners have not learned the use of short sales in the market when cotton is high, and consequently did not take advantage of the high level of prices that prevailed for a part of this season.

As a result, wherever in the South cotton is the chief article to be marketed there is considerable depression of spirits. This is all so unnecessary that it caused much comment among the Northern business men who took part in the tour. If the cotton producers, as soon as they found out that they were going to have a big crop, had sold the market for delivery, say, in January or March and taken contracts to deliver their goods at the level of prices that obtained earlier in the year the condition of

finances in South Carolina and elsewhere in the South would have been vastly different from what it is now.

If cotton costs 8 cents a pound to grow and market, and the present level is not far above that figure, the profits of the cotton planter must be small. If, on the other hand, he had sold short in the market for delivery in January at 14 cents a pound his profits would have been material.

As commercial conditions affect the automobile trade vitally, the cotton market is important to the industry, as regards its southern distribution. The result is quite apparent in the scarcity of new automobiles to be seen on the South Carolina roads.

The highways of South Carolina are mostly built of yellow clay, mixed with varying proportions of sand. As a general rule, they are carefully graded and drained, and in particular spots finely improved. Actual macadam is scarce, but the general average of excellence in the ordinary country roads is higher than that found anywhere along the route to the north.

Of the 134.3 miles covered by the route across the Western end of the state, not more than 20 miles is macadamized and not more than 20 miles can be classed as ordinary road.

The route traverses a section rich in historical lore, passing the battlefield of Cowpens, where the British dragoons and infantry were badly defeated by the patriot forces and driven northward, where they received several other trouncings at the hands of the redoubtable Greene and Morgan. The road was also used

# Where King Cotton Holds Full Sway



5—A fine stretch of road leading through the battlefield of Cowpens  
6—Average roads near Blacksburg used for heavy cotton traffic

7—New road into Greenville. This one has just been finished  
8—The typical South Carolina road, just after leaving Gaffney

to some extent by General Sherman in his famous march to the sea in 1864.

The road enters South Carolina just south of Grover, and the excellent graded road of North Carolina is continued. There are some stiff grades to be covered rounding the foothills of Whitaker Mountain, about 4 miles from the state line, and there is a ford to be crossed before reaching Blacksburg, the first settlement to be passed in the state.

South of Blacksburg the road passes into heavy pine woods, emerging for a moment to cross Broad River and then plunging into the woodland country again on the south side of that stream. There are two considerable grades before reaching Cherokee creek and after that the character of the road changes. Yellow clay takes the place of the red clay that composed the groundwork of practically all the roads to the Virginia line.

The country contains more sand and for ordinary country roads the mixture of sand and yellow clay is ideal. Gaffney, a lively little city, lies 16 miles south of the state line. On leaving this place the road crosses a low range of hills and enters the only really rough spot in the whole way across the state. Even in wet weather this road is not much of an obstacle to the passage of automobiles, as the sand contained in the road-surfacing material gives traction under all conditions. After passing Irene Creek there are heavy grades at intervals clear to Cowpens, a distance of 10 miles.

Most of this distance is through the nearest approach to a wilderness to be found south of Roanoke, but the rolling hills give some evidence of cultivation and as one approaches Cowpens the cotton fields stretch away as far as the eye can reach. The population of this part of the state is sparse and even negroes are not common. But when the vicinity of the old battlefield is reached conditions grow better, and after crossing the Pacolet River, which has been dammed and used to furnish power for extensive cotton mills at Converse, the country improves and at Spartanburg, a fine city of 18,000 inhabitants, there is every evidence of prosperity.

Spartanburg is rated as the third city in point of size in South Carolina and is reckoned to be the second in the United States in the production of cotton-seed oil, besides being in the center of the second largest cotton producing section in the world. Its fertilizer industry is said to produce \$1,500,000 a year.

Leaving Spartanburg a fine macadam road leads southward almost to the crossing of the north fork of the Tiger River. From that point to the middle fork of the same stream the way is through vastly productive cotton fields over good clay roads upon which much work has been done. This is about 52 miles from the state line.

Duncan is the next town of any size to be met with and it is also the largest town on the road between Spartanburg and Greenville, 36 miles. But, in spite of this, Duncan is a mere ham-



Widening new road near Blacksburg. Note the road roller and broken stone

let located on the railroad that connects the two larger cities.

At the crossing of the Tiger river improved roads are again found, the main pike leading through Greer to the south. From the river to Greer the road is excellent and after leaving Greer a fine, level highway typical of the roads of the state is encountered. This continues, following the railroad, or rather followed by the railroad, into Greenville. This section of the state is very rich agriculturally. The soil is sandy loam based upon clay, and while it is considered excellent for everything that grows in warm temperate climates it is devoted almost exclusively to the culture of cotton.

The city of Greenville is located at the foot of the Blue Ridge hills. It is the largest cotton manufacturing center in the South, possessing about fifty large mills, the power for which is derived from the Reedy river. It is close to the summit that divides the flat eastern slope from the more rugged territory that lies to the west.

From Greenville to Piedmont on the Saluda river, about 12 miles, the cotton fields grow a trifle monotonous and the hills and woods to be found after crossing the Saluda are welcome to the eye, but do not endure for long. Some of the finest roads in the state are to be found south from Greenville, the surfacing of sand-clay, carefully smoothed and graded, rivaling macadam in its riding qualities.

It is said that five years ago only about one-fifth as much of a load could be drawn over these roads as can be transported over them to-day in wet weather.

### The Heart of the Cotton Belt

This section is in the heart of the cotton belt and each mile south finds the cotton whiter and the negroes blacker than they were the last mile back on the road. In Virginia the negroes and the cotton were about of a shade. In North Carolina the cotton was fairly white and the negroes were coffee colored. In the northern tier of counties in South Carolina the cotton was pure white and the negroes black and shiny. But south of Greenville the cotton is glistening snow white and the coons lose even their shine of countenance and are deep Cimerian sable without mitigating circumstance unless one throws a small coin among a group along the roadside. Then there is a swift metamorphosis. Faces crack open and enough ivory is shown to relieve the color scheme materially.

The attitude of the negroes in South Carolina will be found to differ sharply from their usual attitude further north. They are exclusively devoted to agriculture and many among them work land on shares, while a very few own the property they till. Toward the born Southerner the South Carolina negro assumes an attitude of great respect. But if he suspects that the white man

comes from the north, particularly from New England, there is sure to be some amusement.

During the Glidden Tour, when the cars were covering this stretch of country, one of the drivers, Thomas Costello, a native of New York, manifestly unfamiliar with the southern conditions, acknowledged the salutes of a party of negroes just outside of Piedmont.

"How are yuh?" inquired Costello genially as his car moved on.

"How ah yu, brothah?" came the response for the crowd, voiced by a huge black woman.

If she had suspected that her white brothah was a citizen of South Carolina she would rather have been stricken dumb than to have made that answer.

The road scene is not changed and lacks much interest to the ordinary tourist clear to Anderson. The roads continue fine all the way in. Anderson is the county seat of Anderson county and is a well-built place, the chief, almost the sole, industry of which is cotton manufacturing. The county raises more cotton than any similar division east of the Mississippi and is exceeded only by some of the Texas counties that are much larger in territorial area than Anderson county.

### Some Rough Country Near Georgia Line

Away on the horizon, the cool shadows of the Blue Hills can be seen, but the city itself is situated in the midst of a flat country where cotton is emphatically king. The city of Anderson has no workable waterpower within the city limits, but the county is well supplied with potential forces for manufacturing. So far only a small amount of this power has been developed, it being estimated that there is something like 125,000 horsepower that is not at work. Anderson county raises not less than one bale for each inhabitant and the mills work up 30,000 bales in excess of the annual production of the county.

## Lincoln Way Prospects

HARRISBURG, PA., Dec. 11—In accordance with the plans of the Sproul good road bill passed at the last session of the legislature for the building of good roads in Pennsylvania, State Highway Commissioner Bigelow is awaiting the action of the present Congress in regards to the Lincoln way before he begins work of building the road from Gettysburg to Harrisburg.

He declares if the way is authorized he will continue the highway to Harrisburg as a double roadway with grass plot and trees in the center. He is hopeful of the way and desirous of building a road to Harrisburg of the same character. Commissioner Bigelow's attitude is an unanswerable argument in favor of the way that he stands ready for the way, illustrative of public sentiment for the way, that he stands ready for the state of Pennsylvania to continue the most magnificent highway ever planned to the capitol of the Keystone state. Mr. Bigelow declares whether he decides to build one or a double road to Harrisburg that the road will be completed in time for the great anniversary of the battle in 1913.

### Harrisburg Club to Fight Bridge Tolls

HARRISBURG, PA., Dec. 11—At the regular meeting of the board of governors of the Motor Club of Harrisburg, held last Tuesday evening at the club's headquarters, Dauphin hotel, it was decided to use every reasonable effort to have tolls on the bridges across the Susquehanna river for all pleasure motor vehicles reduced to uniform charge of five cents for car and driver and one cent for each additional passenger. The present rates are ten cents for touring car and driver and five cents for runabouts and two cents for each additional passenger on all cars. Secretary J. Clyde Myton states that the board is very confident of accomplishing this desirable reform in the toll rate.

South of Anderson to the Keowee river the country continues level and from the Keowee river to the Georgia state line, which is the Tugaloo river, it is slightly rolling. Considerable grades are found, particularly in the latter portion of this stretch. The character of the road is perhaps not quite so high as it was back in the level stretches, but it is well up to the average good road of the South.

The following classification of the roads of South Carolina, as represented by the highway referred to, shows the attitude of the state toward progress. The 20 miles of macadam noted above occur in scattered stretches, particularly entering and leaving Spartanburg, Geenville and Anderson. The longest stretch is the one south of Spartanburg which extends about 7 miles.

The fair to poor roads are those near Gaffney, probably 6 miles of graded new road that makes hard going in wet weather, particularly if deeply rutted. There are also spots of a mile or more to be found at Blacksburg, Taylor, Piedmont and several of them during the final dozen miles north of the Georgia line where considerable work is needed. There are six or seven unbridged fords, none of which is important, but over which bridges and culverts would prove advantageous.

### Convict Labor Used to Improve Roads

Convict labor is used exclusively in country road improvement in the state. There is, of course, much contract work to be found in the cities, but out in the country the sight of gangs of striped convicts at work on the roads is of frequent occurrence.

The state is particularly favored in its natural road material, and, as will be noted in the accompanying series of illustrations, it lends itself to the making and maintenance of fine roads.

A few years ago this whole road was just wide enough for the passage of cotton-laden teams. It was not bad even in those days, but its condition was due to nature quite as much as art.



Widening and standardizing the road from Glover to Blacksburg

There was no effort made to reduce grades, where such reduction would cost any considerable sum of money. To-day, this road is practically new from end to end. Where it follows its original lines it has been widened to 16 feet and crowned to shed water. Some effort to make ditches is also to be noted. While the grades in South Carolina never were really heavy, owing to the flatness of the country, there was room for some improvement in this respect. Since the first real movement began to better the road, fourteen cuts have been made that reduce the average grade to a small fraction of over 1 per cent. This has necessitated lowering the grades over a distance of 18 miles. There never was any great necessity for making fills.

The sand-clay packs easily and when it is dragged, after a shower or period of wet weather, it settles soon into a compact surface that becomes a fine, hard road in dry weather if allowed to remain undisturbed until it has had a chance to shed or absorb the water.

There is approximately 15 per cent. of sand in this surfacing material, and as both clay and sand separately and mixed can be found almost anywhere along the road in quantity the state is peculiarly fortunate in that respect.

### South Carolina's Greatest Needs

What South Carolina needs more than anything else is some diversity in agriculture and a few real hotels. Undoubtedly there is much wealth developed in the state through cotton culture and manufacture, but there would be more inhabitants of good class if there were more different kinds of produce raised. There is a notable lack of good things to eat offered at the tables of the best hotels in the western part of the state at least. The reason for this lies in the fact that there is no effort of commercial size to raise garden truck and the various kinds of meat. The farmers do raise enough for domestic needs and probably live much better than travelers or tourists.

Practically all the table stuff of South Carolina, one of the garden spots of the whole earth, is imported, save at the particular season of the year when the farmers find they have an overplus of produce. This, of course, limits the table sharply at all other seasons and confines it to hog and hominy in many instances.

The hotel buildings are not as bad as the table, but to house such a party as the Glidden Tour they proved utterly inadequate. One of the witty newspapermen who accompanied the tour wired to his journal something like this after spending the night at one of the cities: "The hotel has no baths and nobody could eat the food, but the proprietor has an excellent singing voice."

Thus some good can be found in the direst situation if only one will try to discover it. This applies even to the South Carolina hotel.

## Jeff Davis Highway

LOUISVILLE, KY., Dec. 11—Work on the Jefferson Davis Highway, the proposed 300-mile pike road in western Kentucky, which had its foundation in the convention held at Paducah several weeks ago, has begun in earnest. As soon as the civil engineers complete a survey of Livingston county they will work Caldwell, Crittenden, Lyon and Trigg counties. Owing to its already perfect grading, McCracken county will be the last on the list. Nothing is in the way to hinder the immediate building of the road and it is expected that the highway will be at least half completed within another year. Motorists throughout the western section of the state are deeply interested in the project and it is believed that an extension of the highway will be made later.

### Another Toll Road Abandoned

BALTIMORE, MD., Dec. 11—Now that all tollgates within the city limits have been discontinued the commissioners of Baltimore county are following suit in their territory. The first gate in the county to go was that on the Charles Street avenue extension, which runs through one of the most fashionable suburban sections adjacent to the city. The gate was removed and the road made free through a deed transferring it to the Baltimore County Commissioners. The removal was a great surprise to the residents of that section for they had no previous notice that they were going to be so well treated. The toll road was owned by a subsidiary company of the United Railways and Electric Company, the directors of which, in view of the public sentiment favoring the abolition of toll roads, decided to deed the roadbed to the County Commissioners without cost to the county, but on condition that the company should have the right to lay tracks on the road and run cars over it should a line become necessary.



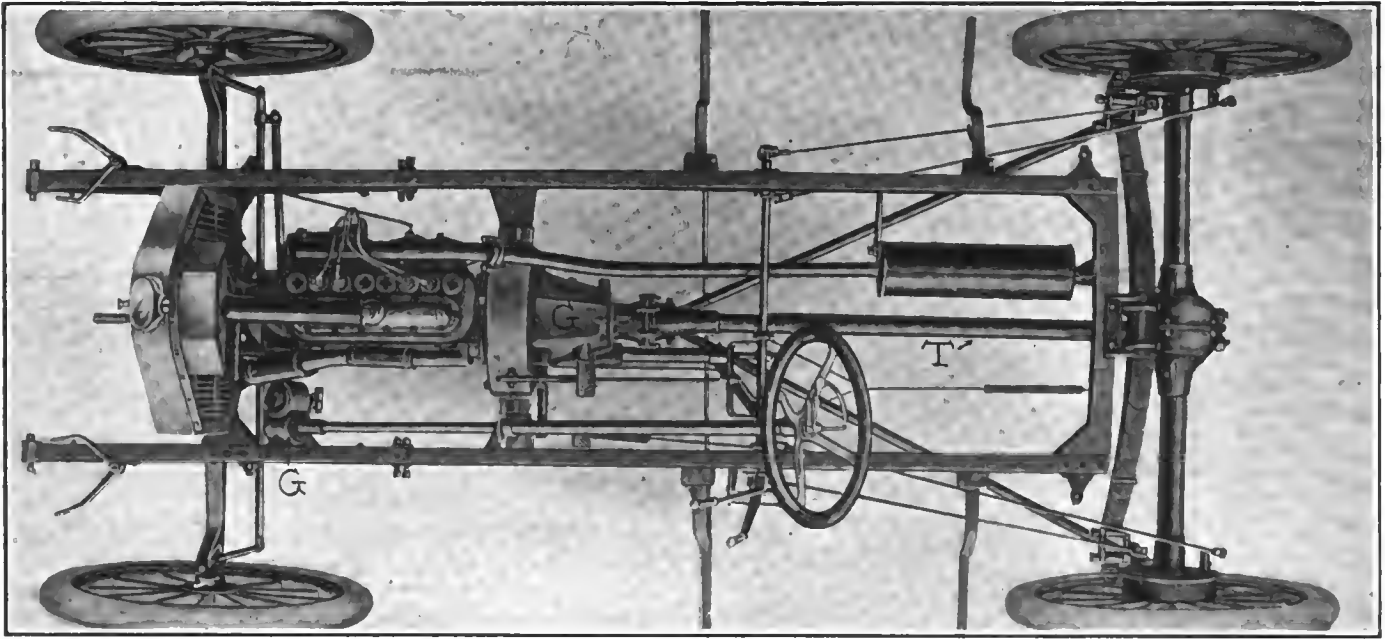

Fig. 1—Plan view of the 1912 Krit model "A" runabout chassis

## Few Changes in the 1912 Krit Line

IN bringing forward its line of cars for the season of 1912, the Krit Motor Car Company, of Detroit, Mich., has made no radical departures from the models of previous years. The underslung model, which was introduced into the line last year, has been continued in order to meet the popular demand for this type of car. The underslung car is classified as model U, while the other two models are known as models A and K.

The motors of all three models of cars are of the same construction, being rated at 22.5 horsepower according to the A. L. A. M. formula and having a bore of  $3\frac{3}{4}$  inches and a stroke of 4 inches. This gives a stroke-bore ratio of 1.065. The four cylinders are cast en bloc with the jackets integral, and, as may be seen from the plan view of the chassis shown in Fig. 1, the tops of the cylinders are faced off to allow of the manifold being

bolted directly on them. The cylinder casting is connected to the crankcase by means of heavy holding-down bolts as shown in Fig. 2. The broad flange which forms a means of connection between the two castings makes for a tight connection through which the oil thrown from the crankcase will not readily leak.

The material of the pistons is gray iron. They are made by being first cast to a rough fit and then machined and ground to accurate size. They are annealed in the process of manufacture so that they are rendered less brittle and able to stand shock better. Each of the pistons is fitted with four rings, to be seen in Fig. 10, three of them being above the wristpin, while the fourth is located just below it. The wristpin, which is shown at P in the same illustration, is driven into the aperture which is located at the center of the length of the piston and is fastened in place by means of the two set screws shown at S. The upper end of the connecting rod is inserted first and the wristpin passed through it. The set screws are then put into their correct positions and screwed firmly home. The lower end of the connecting rod is fitted with a cap, C, which is placed over the crank-bearing and clamped into place by means of the two cap bolts B. The oil grooves in the connecting-rod cap are shown in the illustration. The pistons and rings are lapped into the cylinder so that a tight and efficient fit is secured. The pistons, connecting rods and wristpins of any cylinder weigh the same as any other set, so that one of the factors toward static engine balance is thus secured. Wristpins are hollow and case-hardened, with an oil hole in the center.

The crankshafts of all the Krit motors are carried upon two exceptionally large annular ball-bearings, the balls of which are  $\frac{3}{4}$ -inch in diameter and are

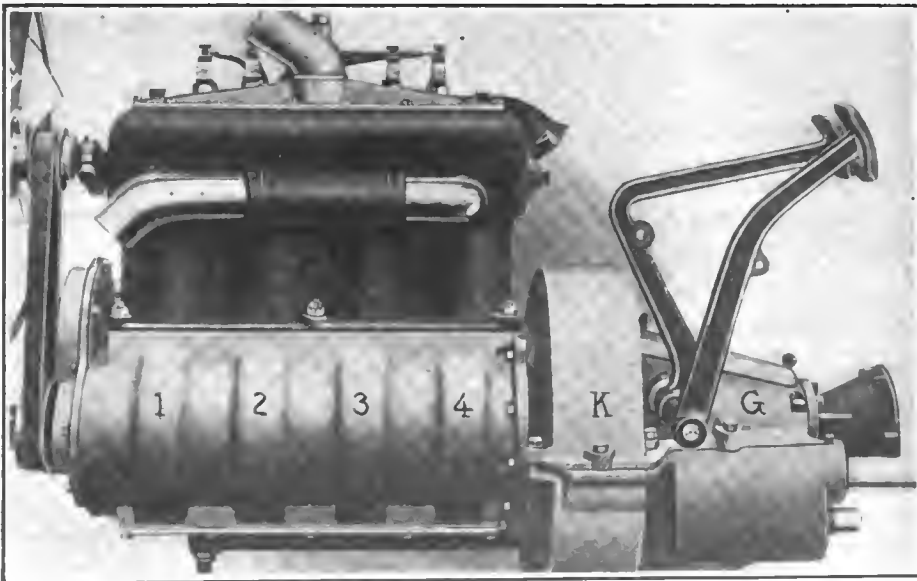

Fig. 2—Left side of motor, showing broad flange for connecting cylinder casting to crankcase



carried in the cages indicated at 1 and 2 in Fig. 10. The shaft itself is a drop forging of special alloy steel. A feature in the construction of the crankshaft is the large connecting-rod bearings which are designed for durability and for the avoidance of the necessity of frequent adjustment.

The valves are completely interchangeable, both the exhaust and inlet valves having the same dimensions throughout and being placed upon the same side of the motor. They are hence driven from the same camshaft and by a single set of cams. The material from which the valves are constructed is nickel steel; they are made thick so that warping difficulties due to the high temperature to which they are subjected have been eliminated to the greatest possible extent. The valve side of the motor is shown in Fig. 3, and from this a fair idea of the amount of valve mechanism exposed may be readily secured. The adjusting device on the tappet-rods is readily accessible as may be seen from the illustration, being located just below the valve springs, which are also exposed. The valve push rods are ground to size and mounted in the cylinder casting, while the valves themselves are ground in the usual manner to their seats.

The camshaft is an integral forging, the cams being one with the shaft. It is carried upon plain bearings which are lined with bearing metal. The camshaft and cams are hardened together and ground to size. The camshaft is driven through a set of half-time gears which are located in a casing at the front end of the motor. The casing is shown in Fig. 3. It is oil-tight but may be readily disassembled by the removal of the small bolts which hold it together. The gears are three in number and are of the spiral type. The breather pipe is an integral part of the timing gear case. The magneto as well as the camshaft is driven by means of this train of gears.

The motor is cooled by water which is circulated by the thermo-syphon system. A free water circulation is maintained owing to the monobloc jacket casting, which reduces the number of partitions around which the water must pass to a minimum, and hence

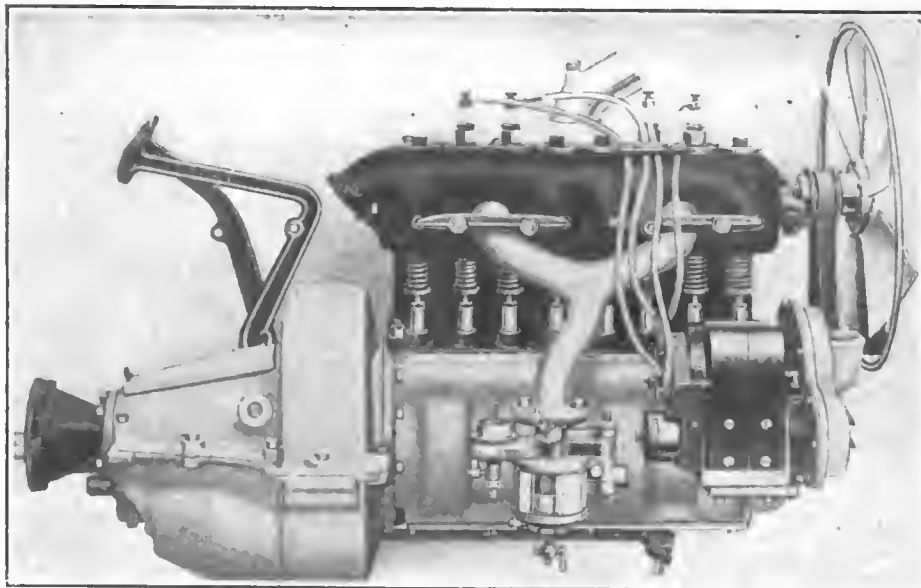

Fig. 3—Valve side of motor, showing small amount of exposed mechanism

aids greatly in the rapidity of circulation. The latter feature is of great necessity in a motor using the thermo-syphon system, and hence has been given special attention. The water piping is of aluminum and is 2 inches in diameter. The connection between the piping and the radiator is of rubber hose, so that all vibrational strains are taken from the metal piping. The radiator is of the vertical tube type, of large size, and is cooled by means of an aluminum fan which runs upon ball-bearings and is driven by means of a leather belt operated directly from the crankshaft. The belt is 1 inch in width and is adjustable for tension.

The carbureter is of Stromberg make and is located on the right side of the motor. This carbureter is of the concentric float type, having the float chamber and mixing chamber in one body. The carbureter is controlled in the usual manner by means of the lever on the steering wheel spider, which, by means of bell crank levers, operates the butterfly throttle-valve in the carbureter.

Ignition is effected by the Bosch high-tension magneto. No battery or coil is used in connection with the ignition system, the magneto sufficing for all purposes.

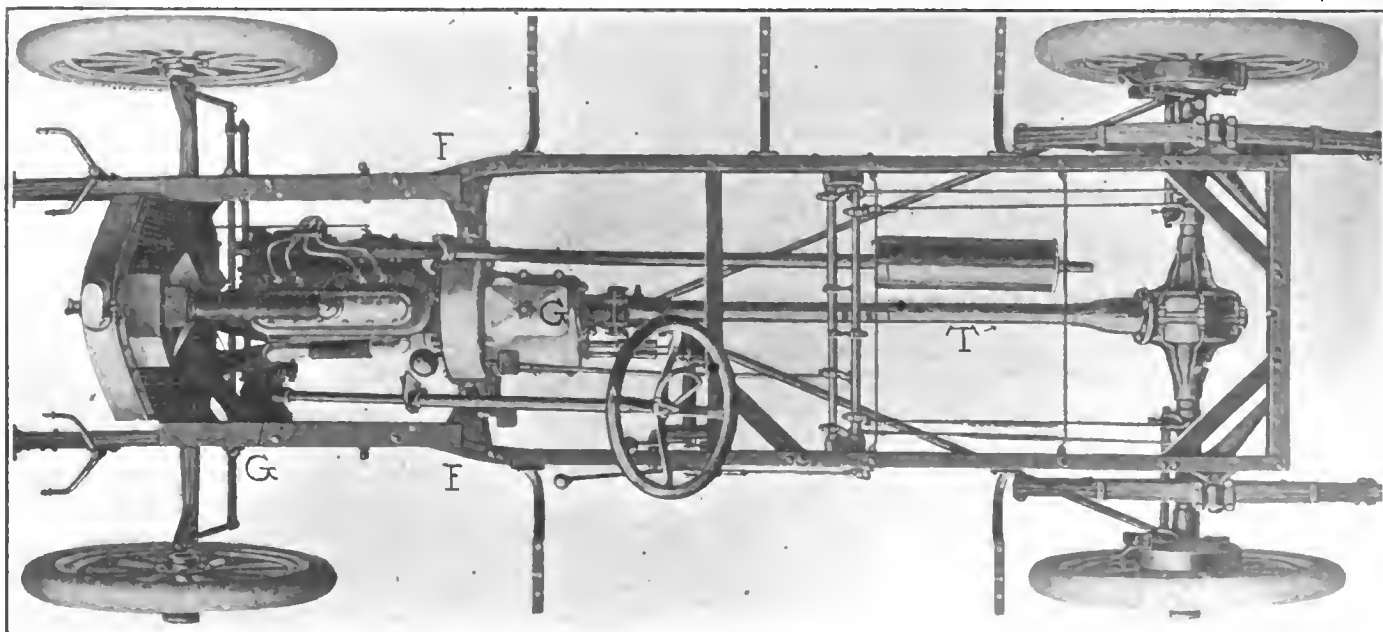

Fig. 4—The Krit touring car chassis, showing its simplicity and compact arrangement

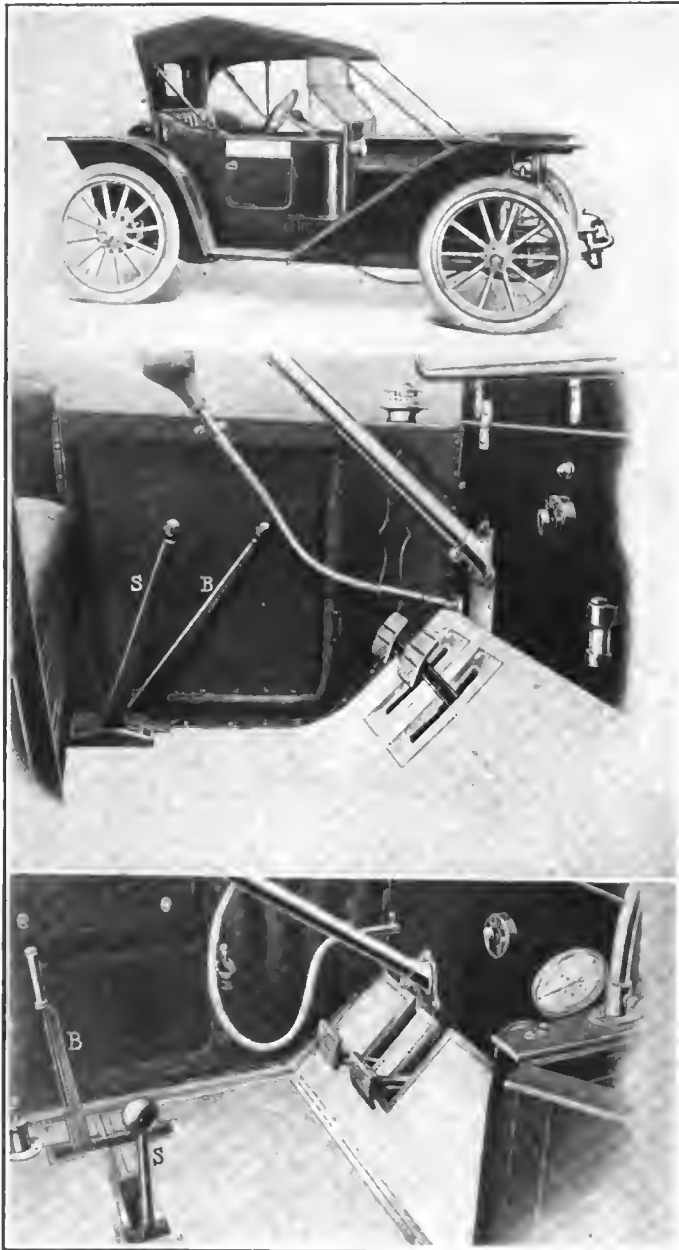

Fig. 5—The Krit underslung roadster ready for the road  
Fig. 6—Roadster dash and control levers

Fig. 7—Gearshift lever is in center on touring car

The motor is lubricated by means of the splash system. The oil is carried in the reservoir which forms an integral part of the crankcase casting. This reservoir, which is located in the bottom of the casting, has a capacity of about 5 quarts and supplies the oil for the lubrication of all moving parts of the motor. A pump, which is driven off the camshaft, lifts the oil from the reservoir in the base and takes it up through a copper lead which passes into a sight-feed located on the dash. All the oil in the lubricating system of the car must go through this sight-feed, so that the operator has at all times a ready means of being able to judge the condition and quantity of oil contained in the system. The oil flows from the sight-feed to the crankcase of the motor. The crankcase is divided into a number of troughs, into which the oil is led. The connecting-rods, as they dip in their stroke, pass through the pools of oil which are contained in these troughs. This churns the oil into a spray, which pervades the entire crankcase and is thrown up into the cylinders.

The pistons on their downward path pick up the oil from the side of the wall and lift it up higher in the cylinders until they are thoroughly lubricated. The purpose of the lower of the set

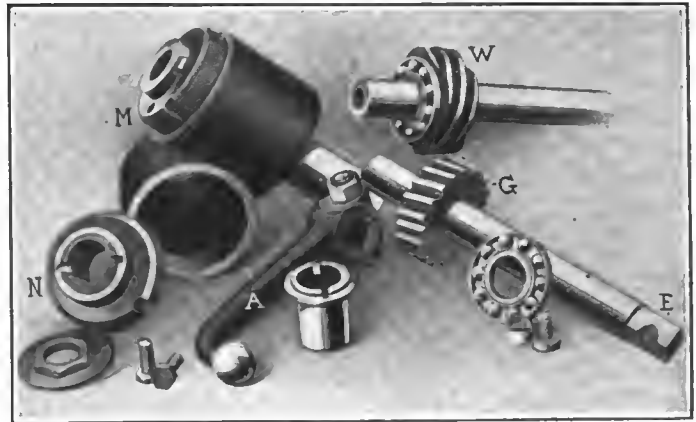

Fig. 8—Parts of Krit steering mechanism. Note ball-bearing thrust

of four piston rings is to eliminate any superfluity of oil and to keep it out of the combustion chamber. The level of the oil in the splash-troughs is kept constant by the supply which passes through the sight-feed. As the oil which is thrown about by the connecting-rods is continually draining back toward the troughs there will be an over-supply of oil in the upper part of the crankcase. This over-supply is taken care of by means of the overflow holes which are placed at the correct level. The oil which passes through these overflow holes passes back into the reservoir in the lower part of the crankcase. Before being recirculated the oil is strained by passing through a wire gauze screen. Oil is supplied to the crankcase reservoir through the breather-pipe. A change has been made in the oiling system of the underslung model in that it is unnecessary to lift the hood, seats or floor in order to replenish the supply of oil in the crankcase. This is also true of the gasoline and water supplies. An oil-pump on the floor of the car takes the oil from the reserve tank and places it in the crankcase. This operation may be made while the car is running.

The housing for the flywheel, clutch and gearset is illustrated in Fig. 9. This is an aluminum casting and is bolted to the aluminum crankcase in the manner shown in Fig. 3. A view of the clutch, which is of the multiple disc type, may be seen in Fig. 9. The discs are shown at C. The gearset shaft is a continuation of the clutch shaft, which is unbroken by a universal joint at this point and is supported by the ball bearings shown at B. The change-speed shaft is located in the lower part of the gearset housing, and is also carried upon annular ball bearings. The entire mechanism runs in oil which is contained in the gearset housing. That the supply of oil may be readily drawn off the gearset and fresh oil provided, there are drain-cocks fitted in the lower part of the housing. The manner of attaching the housing to the frame is shown in Fig. 4 at E. The change speed gear is of the selective sliding type, giving two speeds forward and one reverse. The reverse pinion rests idle while the car is moving forward. The material from which the gears are cut is of special steel. The change-speed gear operates along four keys cut integrally with the shaft. The material of the housing is aluminum. The hand-hole cover G is readily removable by simply turning the hand screw shown in Fig. 10, thus permitting of easy inspection of the change-speed mechanism.

The drive is taken up by the propeller shaft through an enclosed universal joint. The housing, which is connected to the torque tube T, takes all the strain from the universal joint. This is the same construction that is used at the rear of the propeller shaft, where a universal joint is also fitted for the purpose of providing protection against the changes of alignment which occur, due to different loads in the car, and also to the road shocks encountered. Both the universal joints are packed in grease to insure silence and an ample supply of lubricant at all times, as well as to provide against noise in the gears.

Through the rear universal joint the drive is transmitted to the differential, which is of the bevel type. The short differential

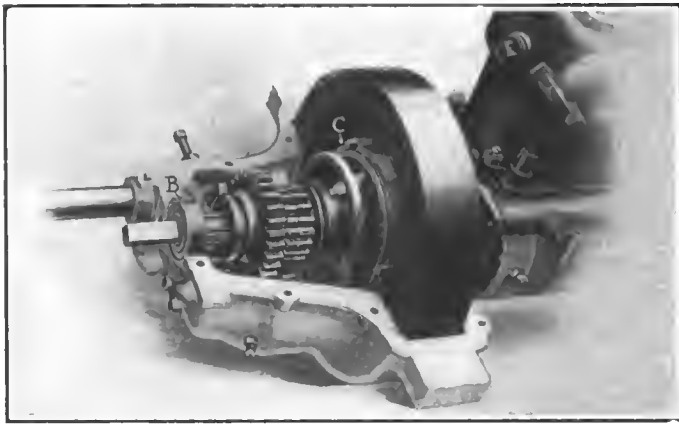

Fig. 9—Showing the simplicity of the clutch and transmission

shaft is carried on annular ball bearings and terminates in the usual star pinion which engages the bevel gear operating the differential wheels. From these wheels the power is transmitted to the semi-floating rear axle, which is carried upon ball and roller bearings.

The service brakes are of the internal expanding type on the models A and U, but on the model K they are contracting. The brakes are located on the rear wheel hubs and operate upon drums which are 9 inches in diameter. The emergency brakes on all the models are of the expanding type and are faced with non-burning material. The service brakes are fitted with equalizers through which the pressure on the drums on either side of the car is made equal; they are controlled by means of a pedal which is operated from the driver's seat. The emergency brakes are operated according to the usual custom, by a lever located to the left of the driver's seat.

The frame is of channel section 4 inches deep for the greater part of the length. It is of straight construction in models A and U, while the model K cars are equipped with frames whose side members are of the same dimensions as in the other two models, but having a single drop. The front axle is a one-piece drop forging of vanadium steel having an I-beam section. The spindles are drop-forged and are also of vanadium steel.

The chassis is supported by semi-elliptic springs in front and in the rear on the models A and U by a single transverse semi-elliptic spring. The model K chassis is supported in the rear by two scroll elliptic springs. The material of which the springs are composed is vanadium steel.

The steering mechanism is of the worm and gear type. It is shown disassembled in Fig. 8. The thrust on the gear is taken by a ball thrust joint designed to eliminate jar on the arm of the operator. The worm is shown at W with the ball bearing in position. The gear G is fitted on the shaft E which carries the arm A, the whole fitting into a sleeve housing M and inclosed by the cover N. The housing is dust-proof and is packed in grease to promote silence and durability in this part of the mechanism. The steering wheel is of Circassian walnut and is 16 inches in diameter. The steering column is rakishly tilted at an angle of 33 degrees. The housing is shown bolted to the chassis frame at G, Figs. 1 and 4.

The wheels are 32 inches in diameter and are made from select second-growth hickory stock. They have twelve spokes and rotate on ball and roller bearings. The tires used in connection with the wheels are 32 x 3 inches both front and rear. On the model U underslung the wheels are made extra large, being 36 inches in diameter and using 36 x 3 1-2-inch tires. The wheel-base of the model A is 96 inches, that of the model U 98 inches and of model K 106 inches. The road clearance is 10 1-4 inches on the underslung model and 11 inches on the other models.

The control mechanism is illustrated in Figs. 6 and 7, where S is the gear-shifting lever and B is the emergency brake lever. It will be noticed that the brake lever is on the left side of the

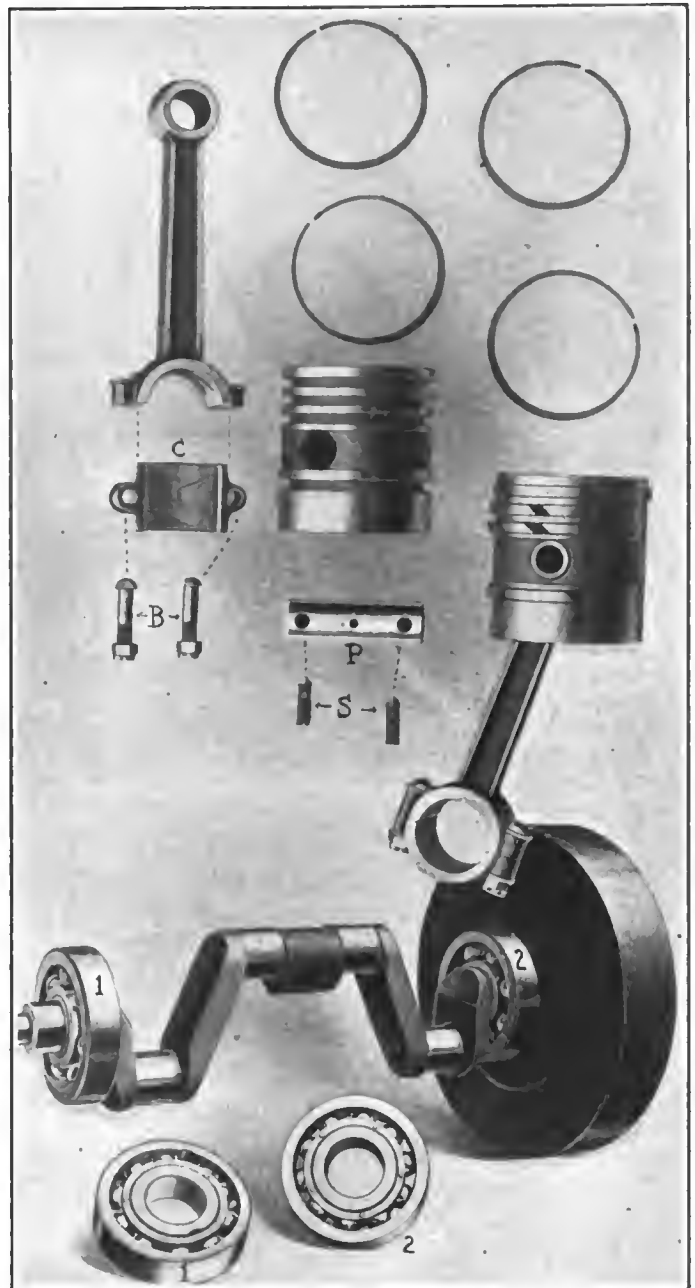

Fig. 10—Some of the Krit motor parts. Four rings are used, one below the wrist pin. The main bearings of the crankshaft are carried on two exceptionally large annular ball bearings

driver's seat on all models. The gear-shift quadrant is different on the model K cars, where three forward speeds are given instead of two.

The equipment furnished with the cars includes three oil lamps, two gas lamps, generator, horn, tool kit, full set of tools, jack, pump, tire repair kit, top including side and corner curtains, windshield and demountable rims.

**ODORLESS BLUE SMOKE**—Experiments are reported in *Chemiker Zeitung* by Dr. F. Schwartz and Dr. H. Schlueter relating to a treatment with acetone of cylinder oil for automobile motors having for their object to remove the components which are least combustible and therefore most liable to cause a disagreeable odor in the exhaust gases. Trying the oil so refined competitively against the oil usually employed, and from which it had been produced, it was found that the new material produced clouds of smoke in case of excessive oiling, but the clouds were odorless. —From *Automobil-Betrieb*. November 1.

# Transmission Ratio and Torque

BY FORREST R. JONES

IT is doubtless well understood in a general way that change-speed gears are used in the transmission system of an automobile in order to obtain, when the gears are set at one of the slower speeds, tractive effort at the road wheels sufficient to drive the car up a steep grade or along a heavy road, to obtain slow speed of travel in crowded streets or on a rough road, and to make the starting of the car certain without running the risk of stopping the motor. The latter applies especially when the clutch is one of those that have the very prevalent fault of taking hold suddenly so that the road wheels must either spin or the motor stop, in either case causing the car to start with a lurch, especially on an upgrade. The tractive effort of the road wheels is due to the rotary effort of the motor which is transmitted to the road wheels through the transmission system. Rotary effort is also known as torque, twisting effort and turning moment.

The rotary effort or torque delivered to the driving road wheels is greater than the rotary effort of the motor, in the usual forms of construction, probably in all forms. This does not mean that the power delivered to the road wheels is greater than that delivered by the crankshaft of the motor. The power received by the road wheels is always less than that delivered by the crankshaft of the motor, because some of the power is lost during transmission on account of the friction at the bearing surfaces which slide or roll over each other. If there were no frictional loss then the power received by the road wheels would be exactly the same in amount as that delivered by the crankshaft of the motor. A clear understanding of this and of the meaning of torque and analogous terms can be obtained by dealing first with some very simple cases leading up to the conditions which exist in automobile transmissions.

Fig. 1 represents a beam provided with three knife edges, A, B and C, such as is used for weighing scales of the beam type. The intermediate knife edge B rests on a support. Each of the other knife edges has a clevice hanging on it, so that weights may be suspended from them. The beam is made heavy at the short end so that it balances on the support when no weights are suspended from the clevices. If a weight is hung on the device at either end of the beam it has a tendency to draw the corresponding end of the beam downward and thus swing the beam around the intermediate knife edge B. The amount of this tendency is expressed by the product obtained by multiplying the weight by the

horizontal distance between the intermediate knife edge B and the knife edge on which the weight is hung. This distance is called the lever arm of the weight. If a 200-pound weight is hung from the clevice on A, and its lever arm is 6 inches, as shown, then the amount of the tendency to swing the beam downward is: 200 pounds  $\times$  6 inches = 1,200 inch-pounds.

The beam can be prevented from swinging by hanging a suitable weight on the

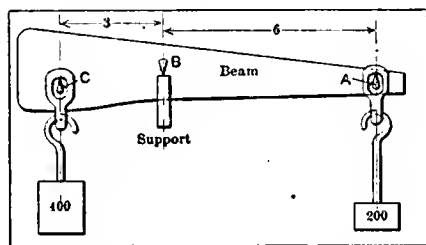

Fig. 1—Conditions of equipoise on lever

clevice at the short end of the beam. The amount of this weight must be such that when multiplied by its lever arm the product will be 1,200 inch-pounds, as before. The lever arm at the short end of the beam is 3 inches. The required weight is therefore  $1,200 \div 3 = 400$  pounds.

Fig. 2 is the end view of two drums and a shaft, all rigidly fastened together and supported by bearings in which the shaft is free to rotate. Each of the drums has a weight suspended by a rope which is wrapped around the drum and fastened at the end to the drum. For convenience it will be assumed that the drums are grooved to a depth such that the tops of the grooves are even with the center lines of the ropes.

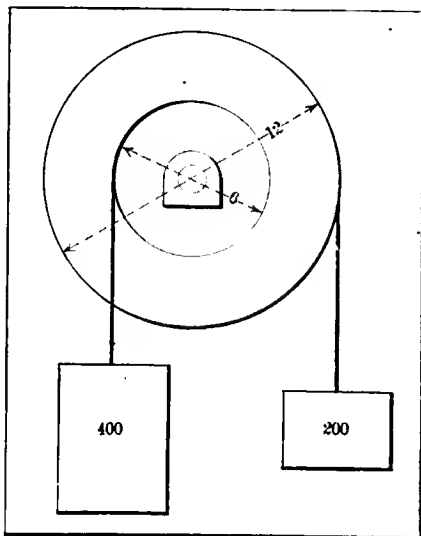

Fig. 2—Balanced weights on shaft and two drums

By this assumption, the radius of the drum is equal to the distance from the center line of the rope to the center line of the shaft. The radius of the drum is therefore equal to the lever arm of the weight that is suspended from the rope that is wound on the drum. The same apparatus is shown in a different manner in Fig. 3. These illustrations are both shown in order to make the construction of the device entirely clear. The weights and their corresponding lever arms are the same in value as in Fig. 1. Each weight has a tendency to rotate the drums and shaft in the direction that will unwind the corresponding rope from its drum. This rotative effort is 1,200 inch-pounds for each weight, obtained as before by multiplying together the weight and its lever arm. The shaft connecting the two drums is subjected to a torque of the same amount, 1,200 inch-pounds, since the rotative effort is transmitted through it from one drum to the other. Only the portion of the shaft between the drums is subjected to this torque, however.

If the drums and shaft are rotated, then the 200-pound weight will move twice as fast as the 400-pound one, since the drum on which its rope is wrapped has twice the diameter of the other drum. If the 200-pound weight descends 50 feet the 400 pounds are lifted 25 feet in consequence. The amount of mechanical energy expended by the lighter weight while descending through the 50 feet is expressed by the product obtained by multiplying the weight by the distance through which it moves, as follows: 200 pounds  $\times$  50 feet = 10,000 foot-pounds.

The amount of work done upon the 400-pound weight to lift it 25 feet, found in the same manner, is: 400 pounds  $\times$  25 feet = 10,000 foot-pounds.

During one revolution of the drums the 200-pound weight moves through a distance equal to the circumference of the drum on which its rope is wrapped. The drum for this weight has a diameter of 12 inches = 1 foot; the corresponding circumference is 3.1416 feet. The mechanical energy expended by the descending 200-pound weight during one revolution of the drum is therefore  $200 \times 3.1416 = 628.32$  foot-pounds.

The amount of work done upon the 400-pound weight to lift it through the distance corresponding to one revolution of its drum, whose circumference is 1.5708 feet, is  $400 \times 1.5708 = 628.32$  foot-pounds, which is of the same amount as the energy expended by the descending lighter weight during the same movement of the mechanism.

If there were no frictional resistance to the movement of the mechanism, then the mechanical energy expended by one of the weights while descending would be just sufficient to lift the other. On account of the frictional resistance to movement which is always present, the mechanical work accomplished is always less than the mechanical energy expended to accomplish it. For convenience, however, it is customary to assume that there are no frictional losses. This assumption is made in order to obtain a method by which the forces exerted to rotate the parts or to resist rotation can be readily computed. An allowance is then made for the frictional losses in accordance with experience or judgment. This method of neglecting frictional losses will be used still further in relation to the different forms of transmissions that will be discussed.

Two gear wheels on parallel shafts with the teeth of the gears intermeshing with each other are shown in Fig. 4. Each of the shafts also carries a drum that is rigidly connected to the corresponding gear wheel. Both of the drums are 8 inches in diameter. One of the gear wheels has forty-eight teeth and the other ninety-six teeth. The forty-eight-tooth gear must make two revolutions to rotate the ninety-six-tooth one through one revolution. This is because the larger gear has twice as many teeth as the smaller one. Since the teeth of the two gears engage each other, a rotative movement of one of the gears corresponding to one tooth plus one tooth space must be accompanied by a movement of one tooth and one tooth space of the other gear. The gears rotate in opposite directions.

Each drum has a weight suspended from it in the same manner as has been used before. When the gears are rotating the 300-pound weight on the drum of the forty-eight-tooth gear moves twice as fast as the 600-pound weight on the drum of the ninety-six-tooth gear, both drums being of the same diameter as has been stated. The distance passed through by the 300-pound weight during any movement of the mechanism is twice as great as that passed through by the 600-pound weight. If the 300-pound weight descends 20 feet the

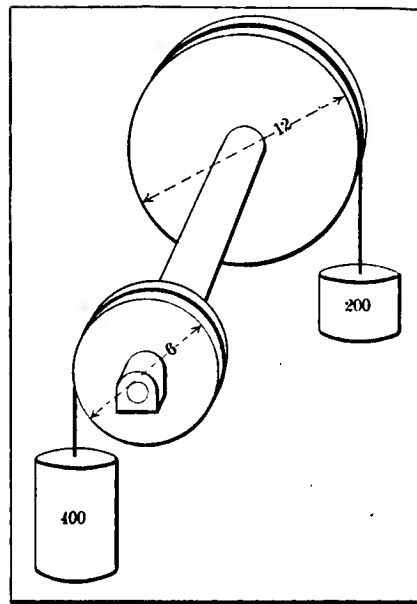

Fig. 3—Perspective view of weighted drum set

the energy given up by it is  $300 \times 20 = 6,000$  foot-pounds. During this movement the 600-pound weight is lifted 10 feet, which requires work done upon it to the amount of  $600 \times 10 = 6,000$  foot-pounds. The energy expended and the work done are equal in amount in accordance with the assumption that there is no frictional loss.

The torque in the shaft of the smaller gear is equal to its suspended weight multiplied by the radius of the corresponding drum. Its numerical value is  $300 \text{ pounds} \times 4 \text{ inches} = 1,200 \text{ inch-pounds}$ .

The torque acting on the shaft with the larger gear is determined in the same manner and is  $600 \text{ pounds} \times 4 \text{ inches} = 2,400 \text{ inch-pounds}$ .

The rotative speeds of the two shafts are inversely proportional to the numbers of teeth in the gears attached to them.

The torques acting on the shafts are directly proportional to the numbers of teeth in the corresponding gear wheels.

The torques are inversely proportional to the rotative speeds.

When the rotative speed of one of the shafts is known that of the other can be found as follows:

Rule 1—When two gears intermesh with each other the rotative speed of the second can be found by dividing the number of teeth in the first by the number of teeth in the second, then multiplying the quotient thus obtained by the speed of the first. Either gear of the pair can be considered as the first.

The rule is otherwise expressed by the following formula, in which one of the gears is called A and the other is called B.

$$\text{Rotative speed of gear B} = \frac{\text{Number of teeth in A}}{\text{Number of teeth in B}} \times \text{speed of A (1)}$$

When the torque acting on the shaft upon which one of the gears is mounted is known, the torque acting on the other shaft can be determined by the following rule, in which it is assumed that there is no frictional loss.

Rule 2—When two shafts are connected together by two intermeshing gears, the torque acting on the second shaft is found by dividing the number of teeth in the second gear by the number of teeth in the first gear, then multiplying the quotient by the torque acting on the first shaft.

The formula corresponding to rule 2, designating one of the shafts and its attached gear as A, and the other shaft and its attached gear as B, is

$$\text{Torque for shaft B} = \frac{\text{Number of teeth in gear A}}{\text{Number of teeth in gear B}} \times \text{Torque acting on shaft A (2)}$$

Fig. 5 is similar in its nature to the last preceding figure. One of the intermeshing gears has forty-eight teeth and the other 120 teeth. The smaller gear and its shaft are designated as A and the larger gear and its shaft as B.

If the gear A is rotated at the rate of 100 revolutions per minute, then in accordance with both rule 1 and formula 1,

$$\text{Rotative speed of gear B} = \frac{48}{120} \times 100 = 40 \text{ revolutions per minute.}$$

The torque in shaft A, due to the 300 pounds suspension from the 8-inch diam-

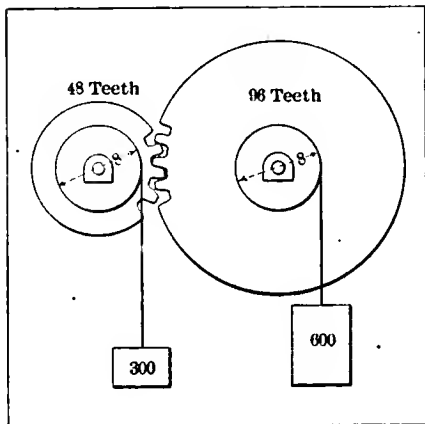

Fig. 4—Torque balanced on half-time gearset

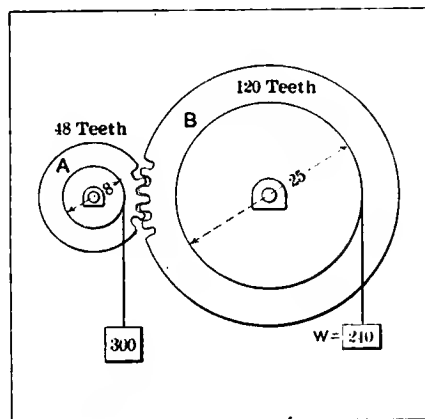

Fig. 5—Balanced torques on 2:5 reduction gear

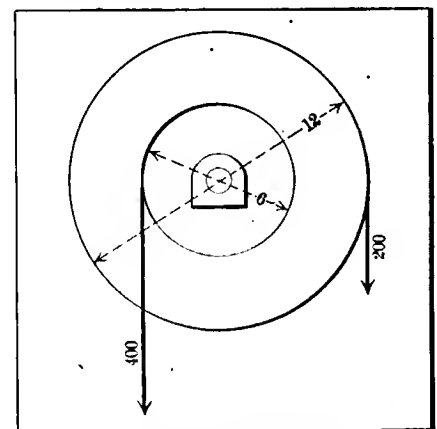

Fig. 6—Vectors indicating loads in diagrams





As shown in the figure,  $M = 16$ ,  $B' = 24$ ,  $B'' = 12$ ,  $C' = 20$ ,  $C'' = 15$ ,  $D = 48$ . By substituting these numbers in the last formula and solving it,

$$\frac{\text{Speed of crankshaft}}{\text{Speed of road-wheels}} = \frac{24 \times 20 \times 48}{16 \times 12 \times 15} = 8$$

This means that the crankshaft of the motor makes eight revolutions while the road-wheels make one.

Since the torques in different parts of a transmission system are inversely proportional to the rotative speeds of the parts when each of the parts is transmitting the same amount of power, the torque delivered to the axles of the road-wheels is eight times that in the crankshaft. It may be noted, however, that the torque delivered to the axles is divided into two equal parts for transmission through the axles, half of the torque going to drive one of the roadwheels and the other half going to the other road-wheel to drive it.

For each 100 inch-pounds of torque at the motor crankshaft there will be  $8 \times 100 = 800$  inch-pounds of torque delivered to the axles, allowing nothing for friction loss. This is also the total amount of torque delivered to the road-wheels, or 400 inch-pounds to each road-wheel. The radius of the road-wheels is 16 inches. Therefore the tractive effort exerted by each road-wheel is

$$\frac{400}{16} = 25 \text{ pounds.}$$

When the side-shaft B and its gears are thrown out of operation, and the motor

shaft connected to the shaft C for direct drive, then the bevel gears are the only ones in operation. The speed ratio of the crankshaft to the road-wheels is then  $48/15 = 3.2$ , and the torque delivered to the axles is 3.2 times that at the motor shaft under the same condition of driving. The tractive effort of each road-wheel for each 100 inch-pounds of torque at the crankshaft is then

$$\frac{100 \times 3.2}{2 \times 16} = 10 \text{ pounds.}$$

In Fig. 9 a pair of reversing gears, R' and R'', rigidly connected together by the shaft R, are shown in the transmission system. As before, the direction of rotation of each shaft and its gears is indicated by the curved arrow around the shaft. The number of teeth in R' = 21 and in R'' = 14. The velocity ratio of the crankshaft to that of the road-wheels is

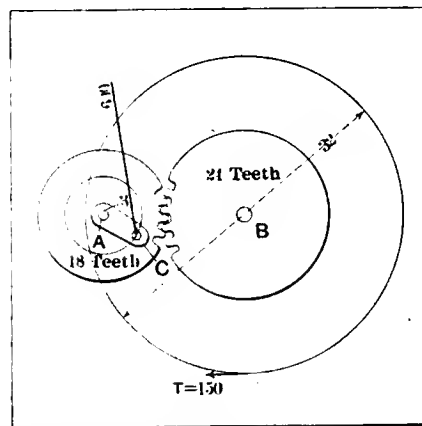

Fig. 7—Multiplying torque delivered at crankshaft

$$\frac{\text{Speed of crankshaft}}{\text{Speed of road-wheels}} = \frac{R' \times B' \times C' \times D}{M \times R'' \times B'' \times C''} = \frac{21 \times 24 \times 20 \times 48}{16 \times 14 \times 12 \times 15} = 12$$

This special ratio is 50 per cent. higher than that obtained for forward travel on slow speed, as has been computed. The torque in the axles and the tractive efforts of both of the road-wheels together are also greater in the same proportion. In the earlier automobiles advantage of this greater tractive effort was sometimes taken to run a car backward up a hill that it would not climb running forward on account of the motor not being powerful enough.

On account of frictional loss of power the tractional effort is of course smaller in each case than the amount obtained by the method that has been used. The actual tractive effort is obtained by deducting the friction loss from the values that have been determined. The amount of power lost in friction varies exceedingly in different transmission systems, and in any one system under different conditions of lubrication and adjustment of the bearings. In a well-constructed transmission system the power lost in friction between the motor and the road-wheels may be as little as 10 per cent. of the power of the motor. The friction loss will run as high as 40 per cent. or more in a poorly constructed or badly worn system while operating on one of the slower speeds.

## Harking Back a Decade

FROM *The Motor Review*, December 12, 1901:

The Henry Ford Co., capital \$60,000, has just been incorporated at Detroit. The company will manufacture an automobile designed by Henry Ford, a mechanical engineer. Mr. Ford will superintend the works.

The fourth annual exhibition of the automobile, the cycle and sports opened at the Grand Palace, Paris, December 10. Alcohol apparatus formed one of the most interesting exhibits. The show of motor implements for agriculture was impressive.

Under a ruling of the United States Circuit Court at Cleveland, the injunction granted against the Goodyear Tire & Rubber Co. on behalf of the Consolidated Rubber Tire Co. has been vacated. The suit was based upon alleged infringement of patents controlled by the Consolidated covering the use of wire passing through the core of the tire binding it to the wheel. The Goodyear company will now be allowed to make and sell tires again.

Four new rules have been added to the racing code by the Automobile Club of America. First, no automobile shall receive further attention and care by others than the driver and mechanic after having been placed in the starter's care. Second, in all races for record automobiles shall be classified by weight. Third, bicycles, tricycles and tandems shall not compete with four-wheelers. Fourth, during the running, only the driver shall have control of the steering power.

Mr. and Mrs. Robert Shaw, of Chicago, have sailed for Paris for a tour of southern France and Spain in an automobile. The Shaws intend to make a more extended tour next Spring.

Exports of automobiles and parts from New York last week totalled \$3,800 in value.

The Century Motor Vehicle Company, of Syracuse, is about to install a new selling plan for its product. This consists in sending factory mechanics into a certain sales territory to demonstrate the performance of the cars. The company is not considering the establishment of more agencies this season because it wishes to test out its plan of demonstrating by the mechanics.

The recent race meeting held at Narragansett Park proved to be a big success in a financial way.

The Chicago Automobile Club has commenced its winter program of entertainments and lectures. The first meeting which was held last week was attended by more members than ever were present at a club function. The club has decided to cooperate with the local golf clubs so that its members may have the privileges of the country houses of the golf clubs in return for similar town privileges for the golfites.

A patent has just been issued to Walter Twitchell on an automatic starting device. This consists of a spring which winds up with a key before starting and when released revolves the crankshaft.

# Digest of the Leading Foreign Papers

## Guiding Thoughts as Voiced by Renault

THE opinions, with regard to the proper principles for automobile construction, entertained by Louis Renault, of France, the well-known manufacturer whose recent visit to American factories is well remembered, have lately been the object of considerable public attention which can be only in part accounted for by the commercial and technical success of the Renault manufacture. The fact that Renault's 1912 cars still bear the imprint of certain fundamental ideas which he conceived before the opening of this century and embodied in his product in opposition to the views then currently accepted, has fostered a high opinion of his intuitive insight, and the fact that he never graduated as an engineer but burst into actual manufacture on a small scale at the age of 19, together with his brother Marcel who was killed in the Paris-Madrid race of 1902, has added a certain glamour to his reputation as a designer endowed with a peculiar understanding of the essentials among a maze of mechanical possibilities.

In connection with his visit to the automobile show in Berlin last month Mr. Renault was interviewed by Dr. Ernst Valentin and the latter has rendered an account of the opinions which were expressed on that occasion; an account in which Dr. Valentin refrains from all criticism while prefacing it with a declaration of somewhat general dissent.

The account deals successively with the first basic principle for choosing among proposed innovations, valveless motors, repair facilities, clutches, spring suspension, metal and wood wheels, maximum and average efficiency of motors, motor lubrication and unit construction. Mr. Renault said, in substance:

"It is a great error to heed the fashions, as doing so cannot be reconciled with the necessity for having every innovation tried out for months or years by competent technical persons.

"My principle has always been the greatest simplicity consistent with greatest durability, and I therefore long ago rejected chain-drive, make-and-break ignition, water pumps and automatic regulation of the motor.

"It should be the automobile designer's aim to get along with the smallest possible number of parts in the automobile and in each part of the automobile.

"I have tried all innovations fully before rejecting them.

"As my views on valveless motors are especially desired, I will say that I have made very extensive experiments with sleeve-valve motors and have reached the conviction that it would be wrong to throw over our excellently proved-out poppet valve system as yet. It is true that the sleeve-valve motor by its noiselessness has contributed to advance the art of construction materially, compelling imitation of this feature, but it is false when the silence of the valveless motor is ascribed solely to the abandonment of the poppet valve. The latest types of poppet valve motors which are also justly designated as noiseless prove the correctness of this view.

"By the abandonment or improvement of the gearing used for driving the camshaft one of the main sources of noise has been removed. Noise can also be obviated by using an elastic coupling between the armature shaft of the magneto and the motor shaft, as for example by the insertion of rubber discs in the coupling. First and last, however—and this is what the valveless motors have taught us—the whole valve mechanism should be encased in the interior of the motor. When the spaces in which the valve-rods work are filled with grease, it is impossible to hear any noise from the valves. And now, since the designers very generally have adopted these improvements, I am of the opinion that

the noiseless poppet valve motor is more practical than the sleeve-valve motor.

"I don't believe in building many things into one unit but in placing each organ which may have to be repaired or inspected distinctly and separately; so that, for instance, a chauffeur may be enabled to take the cylinders of his motor down, clean them and put them together again without going to a factory or to a repair shop. I don't think it is possible to do this with a valveless motor in the same simple manner as with the current design. With the latter you can dismount the cylinder together with the valves without changing anything in the adjustments, and the danger is obviated of getting something changed which you can not yourself readjust as it should be.

"Furthermore, I don't believe it possible to prevent particles of carbon from the lubricating oil lodging in the motor and causing either more rapid wear or a necessity for more frequent cleaning than in the case of the poppet valve motor.

"Just as I have stuck to shaft drive with universal joints, to direct drive and to several other features, uninfluenced by fashion, I feel myself unable to abandon the leather-faced cone clutch. Since 1899 I have used a cone whose apex would be found at about the middle of the transmission box. By this arrangement, which I still consider most practical, the crankshaft is completely relieved of pressures.

"While it may be true that the multiple disc clutch is less exposed to wear than the leather cone, I still ask: Which is better; a construction feature requiring no attention whatever for one to two years and then needing only a new leather facing, or a mechanism which demands frequent attention and lasts forever if it gets it? I prefer a construction with which the chauffeur, if possible, has nothing at all to do so long as the vehicle is in service.

"Since the demand for comfort, in addition to reliability and speed, became general, I have experimented a great deal with spring suspensions and have reached the conclusion that the usual flat leaf springs are altogether satisfactory. But under normal load the springs should be stretched out and not curved, as a stretched spring oscillates more slowly than a curved one and carries the body much more quietly. This is especially of importance for the front springs, because the use of stretched springs there means a minimum longitudinal motion of the front axle. With well designed leaf springs the use of shock absorbers and auxiliary springs is unnecessary.

"Though I was among the first, many years ago, to use wire-spoke wheels on my cars, I have not found them as good as wood wheels. The metal wheel is strong only if made by first-class specialists, and it cannot be repaired offhand. Moreover, the wire spokes are subjected to uncertain strains because they stretch and contract much at changes of temperature. The wood wheel is much more yielding and has a certain springiness in itself. Note also that the Paris cabs which formerly were usually equipped with wire wheels have uniformly gone back to wood wheels. The principal reason for this was the trouble experienced in keeping the wire spokes clean. When the vehicles were cleaned with a hose, water got onto the spoke nipples, and it could not, as in the case of wood wheels, simply be wiped off with a rag or waste. In other words, wire wheels demand more work by the chauffeur, which is against my principles.

"Coming back to the motor, I admit that the fuel efficiency of the slide-valve motor is excellent at the maximum of power de-

velopment. But you cannot run any motor at its maximum without wearing it out much too fast. The average power output must lie far below the maximum, to have reserve power for emergencies as well as for durability. All told, I hold that at the present stage the most advantageous motor to have in one's car is the ordinary type of poppet-valve motor with the valves all on one side, all controlled from a single camshaft, the valves all encased and the camshaft driven by noiseless gears or a chain.

"With regard to the lubricating system, the generally adopted and much praised force-feed circulation of the oil is, in my opinion, wrong. In its circulation the oil is bound to carry along with it minute particles of carbon or detrition material from the cylinders and, however fine-meshed the oil filter is made through which the oil is forced to pass before being used again, it is not possible to avoid some deterioration of the lubricant. Force-feed oiling is also irregular; with a new motor and tight bearings a higher pressure is required to force the oil in between the bearing members than later. And in the case of the crankshaft, the amount of play in the bearings depends largely upon the temperature of the shaft. The extra cost of using oil only once in the motor is insignificant, because the oil used in a circulation system must be thrown away, while that used only once in the motor can be very properly used for the transmission box and the rear axle.

"The so-called unit or block construction, in which the motor and the transmission gear are housed together, I consider illogical, because it results in a construction unit which is too long and rigid for the flexible vehicle frame. It must be suspended at three points, and the load at these points becomes too strongly localized. Furthermore, I consider it advantageous to combine only such elements as never, or at least only at very rare intervals, will require to be taken apart; for which reason I, for example, have taken the distributor out of the magneto and placed it accessibly at the end of the camshaft."—From *Allgemeine Automobil-Zeitung*, Nov. 3.

MASS PRODUCTION AND SCIENCE—A substantial connection between the improvement and cheapening of automobiles and the length of the ether wave produced by a certain red light would scarcely suggest itself to the average mind. It is fully established, nevertheless. The mass production of automobiles, as well as of other complicated types of machinery, depends upon the ability of the manufacturer to turn out the component parts by automatic processes and of such superlative accuracy that the very composite product into which they enter may be assembled from them without any recourse to fitting, filing or trying. Parts intended to be alike must be absolutely interchangeable, and this means in many cases that their dimensions must not vary more than one ten-thousandth part of 1 inch; and even less in the case of scientific instruments themselves used for measuring purposes. But it happens that in industrial establishments there is no available standard for controlling the measurements in the first place. All vary more or less with temperature, and some are subject to certain small periodical changes from year to year or month to month, in some manner related to the changes in terrestrial magnetism. The possibility exists that little inaccuracies, almost infinitesimal though they be, may accumulate—one being added to another or even multiplied through an error in methods—until some day they enter into conjunction with some of the unavoidable errors, due to adjustments by human hands or the wear of tools, and cause a series of parts to be turned out which vary just enough from other parts, turned out previously, to interfere with that complete interchangeability which is indispensable and which in Germany has given the whole method its name, i. e. *das Austauschverfahren im Maschinenbau*.

The modern manufacturing methods referred to have been developed chiefly in connection with automobile manufacture in the United States and are now sweeping into other lines of industry and into other countries, mainly Germany. The need of

an absolute standard of measurement which would be available in factories has been at once felt and is now being met in a practical manner. It is at this point that the absolute length of a light wave, as determined by pure science, steps in upon the industrial arena and contributes an important share to render it certain that the greatest cheapness in automobiles may be combined with the highest quality and accuracy; namely, by safeguarding the only methods of production by which such a combination may be effected.

The foundation for this advancement was laid when the renowned American physicist Albert A. Michelson, of Chicago, while working at the International Bureau of Weights and Measures at Sèvres near Paris, established as a fact, which has been accepted by science generally, that the wave length of the red cadmium light in dry air and at a temperature of 15 degrees centigrade (hydrogen scale) and a barometric pressure of 760 millimeters, equals exactly 1 meter divided by 1553164.13. This standard which can be reproduced in any suitable laboratory at any time and place has also been adopted as normal for all spectroscopic measurements by the International Union for Solar Research. The micro-measuring machines which work with the length of light waves as a basis for comparison make use of the phenomenon of light interference for measuring purposes and are therefore known as interferometers. They have already found an intensely practical application for determining the components of metallic alloys quantitatively by spectro-analysis. The firm Carl Zeiss, of Jena, Germany, has, for example, lately placed in the market an interferometer designed by Professor Haber for the examination of fluids and gases, and in which the light refraction of the fluid or gas is made the means for a very fine determination of the chemical composition, the method being apparently applicable to solutions in acid of small pieces of test metal.

An explanation with many illustrations of the physical laws which come under consideration in the construction of interferometers intended for the standardizing of linear measurements is given in a serial article on "Machine Building with Interchangeability of Parts" by Dr. Ingenieur R. Crain, appearing in the September, October and November issues of *Werkstattstechnik*.

NON-FERROUS METAL EXPOSITION IN LONDON—A show which will be held in Agricultural Hall, Islington, London, May 6 to 18 next, will offer the first public opportunity for passing in review the different metal industries which have nothing to do with iron and steel. Considering the enormous field which has been opened up in this direction through recent scientific progress, it seems remarkable that no one has before contemplated a comprehensive exhibition under one roof of the numerous and varied industrial applications of this relatively new metallurgical knowledge. About fifty different metals are now actually known. The majority of them are still of mainly scientific interest; others are essentially commercial, such as copper, lead, tin, zinc, antimony, gold, silver, platinum. These are the true, the good metals; and their number is gradually increasing at the expense of that of the others. Only a short time ago, vanadium, cerium, radium, iridium, selenium, palladium and several others were chiefly known for their rarity and their uselessness, and now their industrial utilization is widespread. No doubt the exhibition will be widely attended and will be imitated in other countries.—From *La Métallurgie*, Nov. 1.

THE DESIRABILITY OF HAVING SAFE CYLINDER LUBRICATION and yet avoiding partial combustion of the lubricating oil, which leads to smoke and odor in the exhaust as well as to deposits of the unconsumed carbon from the oil, accounts largely for the better results with regard to fuel consumption and regularity in operation which accompany liberal provisions for cooling of the walls of the combustion chamber, though a hot motor in theory should operate most perfectly.

# Letters Answered and Discussed

## Good Practice

EDITOR THE AUTOMOBILE:

[2,949]—I am enclosing a sketch showing the method I use for holding a patch which is being cemented to an inner tube. A small board is placed above the patch and one below it, and the two are clamped together. Someone told me that this was not a good thing to do, as if the clamp was left on for some time it was likely to crease the rubber, causing the tube to crack. Your opinion as to this will be appreciated.

C. F. KEMP.

New York City.

Your sketch has been reproduced in Fig. 1. This method of holding a repair patch is very common, and, as far as we know there is no objection to it. The clamp cannot ordinarily be screwed down hard enough by hand to have any serious results as far as creasing or cracking the casing is concerned.

## Cylinder May Not Be Cracked

EDITOR THE AUTOMOBILE:

[2,950]—I hear that one of the cylinders in an old four-cylinder automobile that I recently bought is cracked and has been

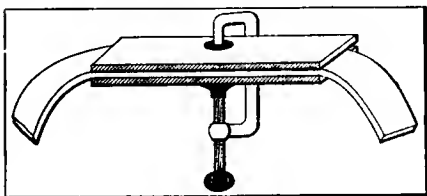

Fig. 1—How to keep a repair patch tight

patched or filled in. I cannot find any trace of the crack, still one of the cylinders does not work all the time. Is there any way in which I can find out which one is cracked, and is there any way to repair it? Also what would be the result if the car is kept running with a cylinder in this condition? Information through THE AUTOMOBILE will be appreciated.

Worcester, Mass.

G. N. W.

The probability is that you have no cracked cylinder, and that the cause of the misfiring in one of the cylinders is due to a fouled spark-plug or to defective wiring. However, there are several ways of testing for cylinder cracks, one of them being as follows: Jack up the rear wheels so that they are free to turn, and drive them by the motor, after having first applied the brakes as a load. Run the engine with the timer advanced. If there is a cylinder-leak gas bubbles should issue from it. A leak which is due to a very small imperceptible

*The Editor invites subscribers to communicate their automobile troubles and personal experiences, stating them clearly on one side of the paper. If the nature of the case permits, send a sketch, even if it be rough, in order to assist to a clearer understanding. Each communication will receive attention in the order of its receipt, if the writer's signature and address accompany it as an evidence of good faith. If the writer objects to the publication of his name, he may add a nom de plume.*

crack will sometimes not appear until the motor becomes well heated under a heavy load. If you are reasonably certain after cleaning the spark plugs and going over the ignition wiring that you have a cracked cylinder the best course to pursue would be to take down the cylinder (or cylinders, if they are not cast separately) and examine it closely along the wall. To our knowledge, cylinder walls which are cracked cannot be satisfactorily repaired, although cracked jacket walls may be restored by electric welding. Thus it is seen that a crack in the cylinder wall is a rather serious matter, especially when two or more cylinders are cast together.

If, after taking down the suspected cylinder, no crack is perceptible it would be as well to put it back as it is, as the loss of compression due to such an infinitesimal leak will not be appreciable.

There will be no ill effects other than the loss of compression and, hence, loss of power, from running an engine having a cracked cylinder wall. There is the possibility, however, of causing the crack to become larger by continued use, and it is not advisable to run a motor longer than necessary when it has a cylinder in this condition.

## Piston Displacement

EDITOR THE AUTOMOBILE:

[2,951]—What is and how do you find the piston displacement of an automobile motor? Please answer through the columns of THE AUTOMOBILE.

H. B.

Pittston, Pa.

The piston displacement is equal to the cross-sectional area of the inside of the cylinder multiplied by the length of the stroke. This is usually expressed in cubic inches. Referring to Fig. 2, take the diameter or bore  $d$  of the cylinder and use it in

$$d^2 \times \pi$$

the formula — to get the area. Next multiply this result by the length of the stroke  $l$  in inches to get the piston displacement.  $A$  is the upper limit of travel of the piston face and  $B$  the lower.

## Wants Information on Ford

EDITOR THE AUTOMOBILE:

[2,952]—How many revolutions per minute is the maximum of which the Ford model S is capable?

(2) Can you tell me how the Ford model S is geared?

(3) Would it be worth the trouble to drill and tap the cylinders for another independent set of spark-plugs in order to get two simultaneous sparks at different points in the cylinders.

(4) Why is the clutch always placed between the engine and the gearset instead of between the gearset and the differential?

OWNER.

St. Louis, Mo.

(1) Maximum revolutions, 1800 per minute.

(2) High speed, 37-11 to 1; low speed, 7 to 1; reverse, 11 to 1.

(3) It would not be worth the trouble.

(4) Because the flywheel offers a convenient housing for it and it would not be good practice to provide the additional weight which would be required by having another heavy housing. In allowing the engine to run free it would be necessary to allow the gears in the gearset to spin around. There are no advantages to be gained in placing it as you mention.

## More Ford Points

EDITOR THE AUTOMOBILE:

[2,953]—(1) It has been shown that electric headlights can be operated by the excess current generated by the Ford magneto,

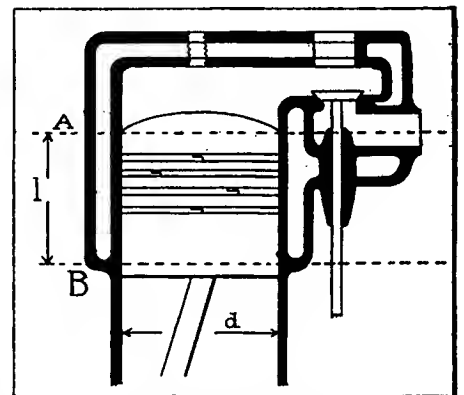

Fig. 2—Diagram illustrating meaning of piston displacement

but when I tried it either misfiring occurred or the motor stopped. Increased engine speed did not affect the misfiring. The lamps were 8-candlepower, 6-volt Tungsten filaments. Can you give me any suggestions as to the trouble?



(2) Are the Ford engine valves constructed so that adjustment of the stems is provided for?

(3) How can I increase the efficiency of the emergency brake, which is internal expanding and unlined? H. L. SHEPARD.

Rochester, N. Y.

(1) The Ford magneto is capable of lighting the headlights, as you state, but you have either wired it up improperly for this service or else you have a double ground in the circuit, caused by improper insulation or a wrong connection. Fig. 3 is a diagram which shows the way in which the headlights and magneto are usually con-

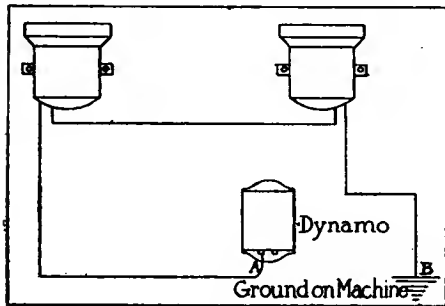

Fig. 3—Wiring diagram for electric headlights on Ford car

nected on the Ford car. The headlights are wired in series. One wire is connected to a terminal of the magneto, and the other is grounded to the frame of the machine. If your headlights are already wired in series as shown the trouble may be due to the fact that you have connected the wrong terminal to the magneto, causing the double ground already mentioned. In this case the connections A and B should be reversed. It is a question whether or not the 8-candlepower lamps which you are using are the best for the purpose. At high engine speeds the electricity generated for lighting may be sufficient to burn out the filaments. On the other hand, if 10-candlepower lamps are used the current at low speeds may not be sufficient to light them.

(2) There is no provision for adjustment of the valve stems of the Ford motor.

(3) As the expense is very small, the best way to increase the efficiency of emergency brakes is to replace the worn bronze shoes.

### Why Experiment?

Editor THE AUTOMOBILE:

[2,954]—In your issue of October 19 you recommend the painting of tires with graphite when laying them up for the winter. Will Dixon's motor graphite answer the purpose? Do you not think that a liberal treatment of sulphur would be just as good? Would you recommend the storing of the tires in a cellar during the winter after either of the above treatments?

Earlsville, Ia. A SUBSCRIBER.

Any good graphite such as that which you mention will do. We have not heard of sulphur being used for the purpose, and

hence cannot say as to the advisability of using it. Why experiment with something that has not been tried out and which is more expensive than graphite when the latter has proven satisfactory and is recommended by tire experts? While the use of sulphur might be even beneficial, automobile tires are rather costly articles on which to try the experiment, especially when there is so little to be gained by it.

If the cellar is not damp and has an even temperature around 50 degrees Fahrenheit no better place could be found in which to store the tires.

### Prefers Broken Crankshaft

Editor THE AUTOMOBILE:

[2,955]—I have been surprised to notice that no exception has been taken to the statement that starting on the spark is detrimental to the motor.

As is well known, the explosive force of a gasoline mixture at atmospheric pressure is very low. That is why a compression of 50 to 60 pounds is used to give an engine power. Now an engine coming to a stop generally oscillates and finally stops with the pistons in a mid-stroke position, which means a low compression pressure. Furthermore a practical test by opening the petcocks after the engine has been standing for a few minutes will usually demonstrate that the amount of pressure remaining in the cylinders is a negligible quantity. This low compression, in connection with a half-condensed, slow burning mixture of gasoline vapor, makes it evident that the pressures and strains produced by starting on the spark must necessarily be much less than those incidental to the normal operation of the engine.

Is not a broken connecting rod or crankshaft cheaper than a broken arm?

Allegheny, Pa. MURRAY FAHNESTOCK.

Conceding the point that a broken crankshaft is in many respects less troublesome than a broken arm, but denying the necessity of either, we still maintain the in-

advisability of starting on spark. The inertia of the stationary parts creates strains on the suddenly started mechanism which are far beyond those incurred in actual running or in starting either by hand or by automatic cranking.

### Other Factors to Consider

Editor THE AUTOMOBILE:

[2,956]—Will you kindly tell a few other of your readers and myself where the discrepancy occurs in the ratings of the Vanderbilt Cup entries. For instance, the Mercedes has a bore of 5.1 inches, a stroke of 7.1 inches, a displacement of 579 cubic inches and 90 horsepower, while the Fiat has a 5-inch bore, a 7.48-inch stroke, a displacement of 588 cubic inches and 70 horsepower. Here are two cars, one having less bore and longer stroke than the other, yet with such vastly different horsepowers. Will you kindly explain?

ALFRED P. STEWART.

Charleroi, Pa.

Other factors besides the bore and stroke enter into the horsepower rating of a motor. The speed and compression pressure must also be taken into account. On page 1005 of our issue of December 7 you will find an explanation of this same point.

### Direction of Cooling-water Flow

Editor THE AUTOMOBILE:

[2,957]—Will you kindly tell me the direction of flow of the cooling-water? Does it flow in at the top of the radiator and out the bottom, or vice versa? Also please tell me where in the cooling-water circuit the pump is placed?

Memphis, Tenn.

A. L. CROSS.

The arrows in Fig. 4 show the direction of flow of water through the cooling system. The water enters the radiator at the top and flows out at the bottom. The pump is located as shown, between the manifold which admits the water to the jackets and the outlet pipe from the radiator.

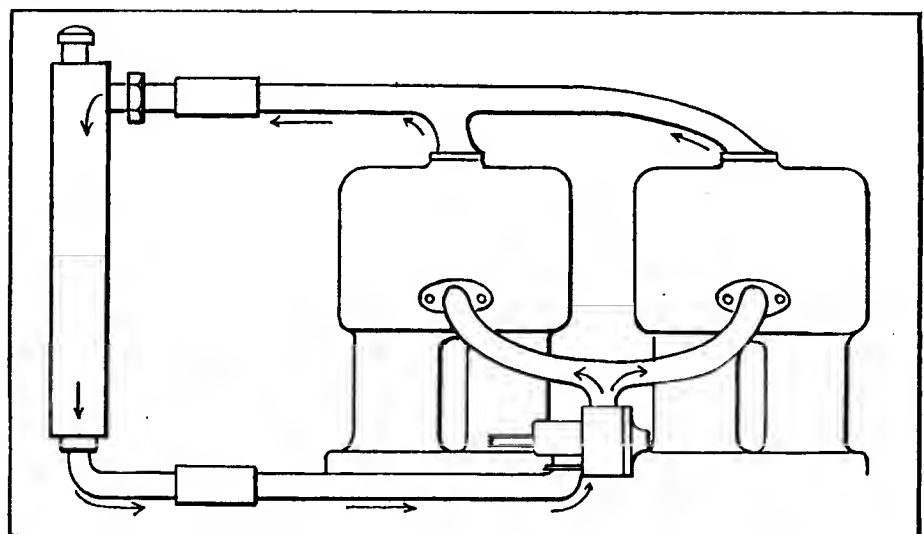

Fig. 4—Illustrating direction of water flow in cooling gasoline motor

# Little Bits of Motor Wisdom

## Pertinent Pointers of Interest to Repairman and Driver

**R**PAIR OF BROKEN SPRINGS—To the automobilist who has smooth, level roads on which to drive his car and to careful drivers, spring troubles are practically unknown. But in hilly localities and in places where the roads are rough mishaps to springs are not an uncommon occurrence. Springs are often broken by sudden jolts due to driving the car at a high rate of speed over rough roads where there are deep ruts and where the approaches to culverts are not properly graded. Accidents of this kind are usually due to carelessness in overloading the car and in driving, but, nevertheless, they do happen, and a few suggestions as to temporary spring repairs will not be amiss.

A break in the upper leaf is most common, the part nearest the hanger usually being bent upward. At A, Fig. 2, is shown a rather makeshift but effective spring repair for a break of this nature. If you are on the road when such a mishap occurs and have no spring clips or extra pieces of spring leaf at hand, this emergency repair will prove very satisfactory. The car should be first jacked up, the jack being placed at the end of the hanger. This will serve to relieve the tension on the under leaf and will bring the bent or broken upper leaf down somewhat. Next take a wrench and adjust its jaws so that they are far enough apart to go over the spring leaves at the point nearest the hanger. Then drive the wrench along the leaves toward the break, using a hammer and cold chisel (or other piece of steel) if necessary. This will serve to bring the bent upper leaf nearly down to its original position against the lower leaf. Next take a piece of hard wood about a foot long and shape it to the width of the spring leaves, as shown. Bind this block down firmly to the spring with whatever strong wire is at hand. It is a good plan to wind tightly over this wire a piece of clothes line rope, or other strong rope of about the same size, and then to wet the rope, causing it to contract, thus binding the joint very tightly. The wrench

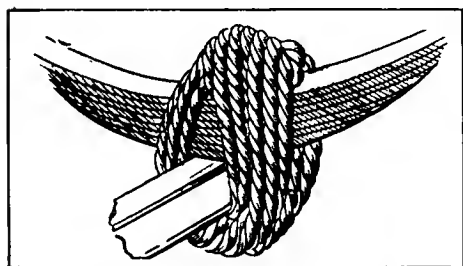

Fig. 1—An improvised bumper

can now be removed, and the spring, though weak, will be found to be quite strongly repaired.

The repair above outlined can be made use of when no spring clips or extra pieces of spring plates are to be had. When using a car on rough roads, it is well to include these things in the repair kit. A spring clip is shown at B, Fig. 2, and another and better way of repairing a broken spring leaf is seen at C. This repair is very satisfactory, and the car can be used with a spring fixed in this way until such time as the broken member can be conveniently replaced.

The piece of spring steel is first placed over the break, as shown, and the clips are then slipped on. Small blocks of hard wood are placed on the under side and the lower plates of the clips are bolted on over them. The particular advantage of this repair lies in the fact that the parts of the broken leaf can be readily brought down into their normal positions against the next lower leaf simply by tightening up on the nuts. For further strengthening, one or two more clips may be added, blocking them on the bottom in the same manner.

Of course, a repaired spring will not be as strong as the others, and for this reason it is likely to bump the frame whenever the car is jolted. If the car is not fitted with rubber bumpers or shock absorbers it is a good idea to place a block of wood at the spring center and bind it on with as many parallel turns of heavy rope as possible. This improvised form of bumper is shown by Fig. 1. This will serve to soften the impact, reducing the jarring of the frame and preventing it from becoming localized. When a garage or accessory station is reached this rope bumper should be replaced by a more suitable rubber one.

Any of the good forms of shock absorbers on the market materially reduce the chances for spring breaks, and wherever possible they should be included in the equipment of the car. Their cost is small in comparison with the trouble and expense incident to the repair of a broken spring. This is aside from the easier riding qualities which a full set of shock absorbers gives to the car.

**HORSEPOWER RATINGS**—Considerable confusion exists among automobilists and others as to the distinction between the various methods of determining the horsepower ratings of motors. As a matter of fact, there is a very large distinction be-

tween these methods, even though a great many persons do not appreciate it. Because a manufacturer states that the (A. L. A. M.) rating of his engine is a certain horsepower it does not necessarily follow that the actual horsepower which the motor will deliver on a brake test will correspond with his rating. Most manufacturers rate their motors according to the A. L. A. M. standard. The formula which this body has set down states that the horsepower shall equal the product of the square of the cylinder diameter multiplied by the number of cylinders which the motor has, and this result divided by the constant 2.5. This latter figure is used because it is "based on the average view of the A. L. A. M. engineers as to a fair conservative rating for a four-cycle motor at one thousand feet per minute piston speed." Motors rated according to this standard are usually given a horsepower much below

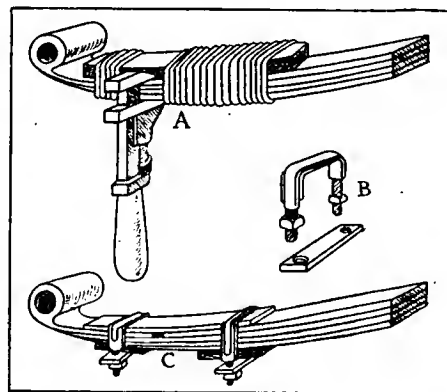

Fig. 2—Two good spring repairs and a form of spring clip

that which they are capable of developing under load. The formula does not take into account the compression pressure nor does it make use of the piston displacement, both of which factors are considered when the horsepower is determined by more accurate methods. The A. L. A. M. standard is of use for commercial purposes only in that it affords a means of comparing automobile motors as to power, but not as to the exact amount of this power. Thus, we say a certain car has 20 horsepower, according to A. L. A. M. rating, and another, 30 horsepower. The actual horsepower may be around 30 and 40, respectively, but so far as the comparison of the two motors as to relative power goes, the more approximate rating answers the purpose equally as well as the other. Frequently we are asked to explain wherein the discrepancy lies between the

engine ratings of various racing cars as set forth by the entry tables. Often two cars of nearly the same piston displacement are entered with widely different horsepowers, and this leads to a great deal of confusion in the minds of many. This horsepower difference is usually due to the variation in the design of the motors. It may also be due to the fact that either one of the cars or both have not been rated according to the A. L. A. M. standard, unless the only variables, the cylinder diameters, are far enough apart to make up for the difference. That is, if two motors have four cylinders each,

$$D^2N$$

in the A. L. A. M. formula — the only factor which can cause the variation is  $D^2$ ,

$$2.5$$

which is the square of the cylinder diameter. N represents the number of cylinders. Therefore, even though the piston displacements of the two may be about the same, in one case this may be made up by a long stroke and a small bore, while in the other the cylinder diameter may be large and the stroke short. Thus, the bores are not the same, consequently the ratings by this formula cannot be the same. A specific example will no doubt serve to illustrate this more clearly. Take, for instance, two four-cylinder motors, one having a bore of 5 inches and a stroke of 4 inches, and another having a bore of 4 inches and a 6 1/4-inch stroke. Each motor has a total piston displacement for the four cylinders of approximately 314 cubic inches, yet by substituting in the formula already given the motor with the 5-inch bore receives a rating of 40 horsepower, while the other figures out to be 25.6 horsepower. Of course, the piston speed is vastly different in the two cases, and it is unfair to use the constant 2.5, which is based on one thousand feet per minute piston speed, to compute both horsepowers. While the formula is very poor at best, it is seen to be absolutely worthless, unless the constant is changed to meet the specific conditions.

Another more nearly accurate and consistent way for getting at the power of a motor is by means of the indicated horsepower formula, which states that the latter

$$(M. E. P.) \text{ is equal to the expression } \frac{33000}{L}$$

In this formula L is the stroke in feet, a is the area of the piston face in square inches, n is the number of explosions per minute (usually considered as being half the number of revolutions per minute) and M. E. P. is the "mean effective pressure" acting within the cylinder throughout the cycle. The only difficulty arises in determining the last-named factor. It must be determined from an "indicator card" taken while the engine is running under load. For taking this card an indicator must be used. There are several types of these instruments on the market, one of them (Thompson) being shown in sec-

tion by Fig. 3. The pointer traces on a paper attached to the drum, a diagram having pressure and volume co-ordinates in proportion to the actual pressures for the various volumes or positions of the piston throughout the entire cycle. This diagram is integrated—that is, its area is determined by planimeter or by computation, and, after taking into account the scale of the indicator spring, the mean effective pressure is determined by dividing the equivalent area by the length of the stroke.

For testing an automobile engine the in-

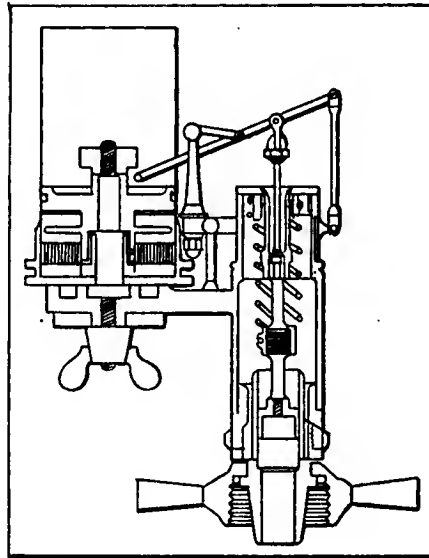

Fig. 3—A type of indicator to measure mean effective pressure within a cylinder

dicator may be attached to the cylinder by screwing it into the priming cock hole. Cards need be taken on one cylinder only, and the result obtained by the above formula can then be multiplied by the number of cylinders to get the total power of the motor. It is sufficiently accurate to assume that each cylinder furnishes a proportionate part of the total developed.

Perhaps the best method of getting at the horsepower output of a motor is by means of a Prony brake. The apparatus may be fitted up as shown by Fig. 4. The test can only be performed when the motor has

been removed from the frame and mounted on some sort of testing block, such as is used in the garage. The Prony brake proper is shown by B. The strap D is put around the flywheel C, and its tension is regulated by means of the handwheel or other adjusting screw A. The end of the brake beam bears on the block E which, in turn, rests on the platform F of the scales. The motor is started running and the load applied by tightening up on the adjusting screw, the direction of rotation being as shown. To get the maximum brake horsepower of the motor the screw A is turned until the friction is barely overcome—that is, until the motor is running under such a load that a slight additional tightening of the strap D will stop it. When this adjustment is reached the friction is weighed by the platform scales, and the speed is noted with a tachometer or speed-counter. These readings should be taken, of course, when the motor is developing all the power of which it is capable.

Having obtained this data, the following formula is applied:

$$\text{Brake horsepower} = \frac{2\pi GAN}{33000}$$

The symbol  $\pi$ , of course, represents the constant 3.14, while G is the weight shown by the scales, A is the length of the brake arm in feet from the center of the flywheel to the center of the block E, and N is the number of revolutions per minute of the flywheel as obtained by means of the speed-counter.

When the test is properly carried out it gives a very near approach to the correct power output of a motor.

Another method of testing which is made use of chiefly by manufacturers is to direct-connect the motor under test to an electric generator, causing it to drive the generator and noting the electrical output in watts. The watt output can then be reduced to horsepower. This equivalent horsepower comes very near to the correct delivery of the motor, although it is slightly less than it should be unless the efficiency of the electric generator is taken into account.

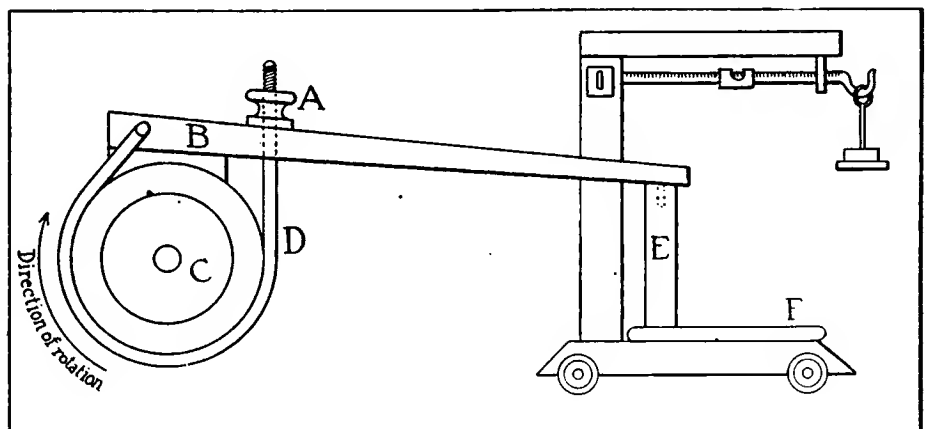

Fig. 4—Apparatus for making a brake test

# My Best Automobile Repair

## Some Quick Repairs Made in the Garage and on the Road

### An Effective Lock

EDITOR THE AUTOMOBILE:

Several lock devices have been gotten out to prevent the automobile motor from being started by anyone except the person who is in possession of the key and they are all more or less practical. This provision is oftentimes very necessary when the car is allowed to stand for some time on a busy street with no one to watch it. Very often a car has been stolen at night by thieves who are able to start the motor by simply switching on the ignition current. I have never had any trouble of this kind, but I believe in the ounce of prevention and am sending you a sketch of the way in which I prevent the car from being used without my knowledge. Inside the battery box I have fastened a switch of the type used in electric light circuits. Fig. 1 shows a section through the box. The switch is seen fastened to the back of this box. If the box is of metal, a board can be fastened inside to its back and the switch then screwed on to this board. The switch is simply put in one of the wires leading from the battery, as shown. When the driver is to leave the car for some time the switch is turned off and the battery box locked.

It is safe to say that the thief or joyrider would give up the attempt to make away with the car when he found that he was unable to start it by switching on the current. Even if the battery box were not locked, he would hardly risk further investigation into the reasons for the motor's failure to run.

If the car is kept in a public garage, some such device as this gives the owner a feeling of satisfaction in knowing that there is no chance of his machine being taken out and possibly damaged by the garage employees. CAREFUL MOTORIST.

Philadelphia, Pa.

### Protects Terminals

EDITOR THE AUTOMOBILE:

A useful hint to some of your readers may be gained from Fig. 2. On most cars all terminals are exposed, and hence there is liability of leakage from them to the adjoining metal parts. To prevent this, one way is to slip pieces of rubber tubing over them, as shown. This applies not only to the spark plug terminals, but to those on the magneto and battery as well. This tubing also serves to prevent the jarring loose of the connections. Nothing

*Temporary automobile repairs made by the driver or owner while on the road and permanent repairs made in the garage after the run is over, are interesting to all automobile owners.*

*It may be a spring leaf has broken; a shackle bolt or strap may break; a steering tie rod is bent; the car skids into a curb and bends a steering arm or the starting crank; a throttle or magneto connection breaks owing to vibration; a radiator leak is started by a stone or some other means; a leak in the gasoline tank is discovered; there is a small hole in the gasoline feed line; a brake facing may burn out; a brake connection breaks; a front axle gets slightly sprung; a clutch starts slipping, or any one of a thousand things may happen.*

*Every automobile owner is interested in knowing how repairs have been made, how long it took to make them, how much they cost, and by whom they were made.*

*We want you to write in simple language in a letter what repair of this nature you have had to make, how you made it, how long it took you and how much it cost.*

*You can make with your lead pencil one or two rough sketches indicating the broken or damaged part and showing how the repair was made.*

*The experience of each reader is interesting to every other reader. Analyse your past experiences and send in one or two of them.*

*Give your name and address, legibly written. If you do not want your name to appear, make use of a nom de plume.*

Editor THE AUTOMOBILE.

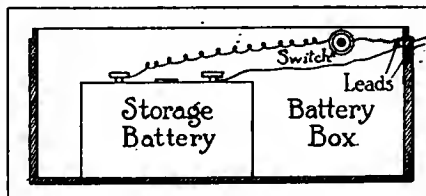

Fig. 1—Battery box switch

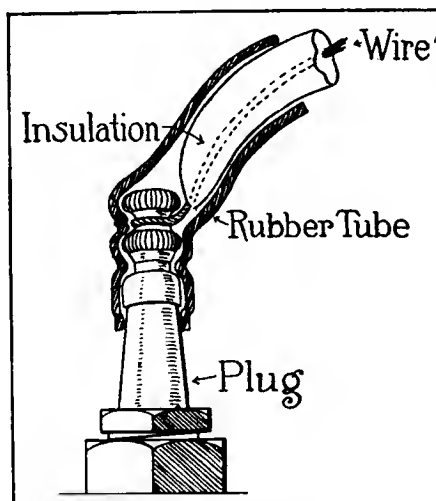

Fig. 2—Terminal protection

is more annoying when on the road than to have the motor stop for no apparent reason at all, and after going over half its parts to find no more serious a trouble than that a connection has jarred loose from its terminal. If the tubing does not readily slip over the terminals or plugs, it may usually be made to go on easier by wetting it slightly.

B. L. BARNES.

New York City.

### Need of Safety Cranks

EDITOR THE AUTOMOBILE:

Just the other day I read in the paper of another broken arm as the result of trying to start a motor with the old-fashioned starting crank. There are on the market a number of safety cranking devices, which are made so as to be applicable to any car, yet the majority of automobilists still persist in using the old-style crank when one of the newer and safer ones could be added at small expense. Since having one of these put on my car I do not have the former guilty feeling when a friend cranks the motor for me.

V. L. GASS.

Boston, Mass.

### Product of a Fertile Brain

EDITOR THE AUTOMOBILE:

While this is not exactly to be classed as a repair, I think the suggestion might be of service to some other automobilist when he is out in the country sometime, and, after it starts to get dark, he discovers that the acetylene supply in his tank is very low. In fact, that is about what happened to me the other night. About dark I started out blissfully for a run in the country, and when I had gone perhaps 15 miles the headlights began to get dim, and finally went out. I was seriously considering abandoning the car for the night when I saw the lights of a country store shining dimly, perhaps 100 yards up the road. This gave me an idea, and I walked ahead to the emporium. There I bought two candles and begged a generous supply of string. Returning to the car, I tied a candle firmly to each gas jet and lit the candles. To my great joy, the light furnished by these old-fashioned articles when the reflectors were properly focused, was bright enough to enable me to proceed slowly, but none the less safely, to the nearest gas supply station. Now I carry a few candles as part of my car's equipment.

Yonkers, N. Y.

J. C. HARRIS.

# My Ideal 1912 Automobile

## Readers' Conceptions of What Next Year's Car Should Be

### A Long-Stroke Advocate

EDITOR THE AUTOMOBILE:

I have read with no little interest the articles on My Ideal Automobile and have decided to outline the car which I would like to own for 1912.

The motor should be of the four-cylinder, four-cycle, T-head type. The cylinders should be cast in pairs with a bore of 4 3/4 inches and a stroke of 7 1/2 inches. This should give a motor of about 60 brake horsepower. The electric current should come from a Bosch dual system, and the cooling should be by a honeycomb radiator and a gear-driven centrifugal pump. Oil should be supplied by a splash system and by a pump which would force the oil through a hollow crankshaft to the main bearings of the motor. The carbureter should be a G. & A. and a B. & L. Castor front axle should be included. The rear axle should be of the floating type, manufactured by Timken. The wheelbase should be about 130 to 134 inches, and the car should be equipped with 38-inch by 5-inch tires all around.

The steering gear should be similar to that used in the Marmon 32. The transmission should have four forward speeds and a reverse, with direct drive on the fourth speed, geared two to one. The springs should be semi-elliptic front and rear. The clutch should be a large cone with cork inserts.

I would have a roadster type of body, seating two, with large gasoline and oil tanks placed behind the seat.

I should think that a car such as I have outlined could be made to sell for about \$2,750 or \$3,000 and yet be built from the best of materials.

GEORGE BRIGGS.

Sheffield, Mass.

### Wants High-Powered Car

EDITOR THE AUTOMOBILE:

My ideal 1912 automobile would have a horsepower around 80, the engine bore would be 5 inches and the stroke 7 inches. There would be six cylinders, cast in pairs, with water cooling and T-heads. The ignition would be by Bosch dual system with governor control. Lubrication would be by force-feed to all bearings and by independent splash. There would be oil level cocks and drain plugs to all crank pits, gearcases, inclusive of transmission and differential housings, with generous oil holes.

The clutch would be multiple disc with 52 steel plates running in oil and with a gener-

*Readers continue to demonstrate their interest in the ideal car and the specifications which are submitted show a wide range of taste and requirements. In view of the interest shown the Editor continues to extend the invitation to all who entertain ideas on this absorbing topic to submit their opinions for publication. The description should be legibly written on one side of the paper and signed by the sender, although if it is so desired the name will not be published.*

ous carrier. The transmission would be of the four-speed selective type with the following gear ratios: 1, 9 to 1; 2, 5 to 1; 3, 3 to 1; 4, 2 1/4 to 1; reverse, 9 to 1. The drive would be by shaft and the universal housings would be grease tight. I would have semi-elliptic springs on the front and platform springs on the rear. The wheelbase would be 135 inches and the tires would be 37 inches by 5 inches. The rear axle would be floating with Hess-Bright bearings, and the front one would be tubular, hot-riveted with Timken bearings. The control would be by foot and hand throttle with a cut-out button on the wheel. For brakes I would use two expanding and two Raymond contracting on the rear wheels.

The features of the body would be a seven-passenger, fore-door, straight-line body with plenty of leg room for all seats, full spring, hand-buffed, hair-filled leather seats, 30-gallon gas tank under pressure under the front seat, tool box at the rear, cowl dash, self-locking door catches.

The equipment would include a self-starter, Gray and Davis full electric light system, Warner clock and speedometer, Banker windshield, pressure, volt and ammeter gauges, oil sights, Continental quick-detachable, demountable rims with two extra rims carried at the rear of the body in a special cradle fastened to the rear from a cross piece, Goodrich tires carried in a metal trunk along with tubes, jack and pump, storage battery to be carried under the rear seat, all wires leading from it to run in lead conduits. The object would be to keep the running hoards free from all boxes or tanks.

The top would be of the best mohair, five-bow, strap-hung. The cushions and tire covers would be of the same material. The top of the frame would not be over 25 inches from the ground, and the seats would be comfortably low.

The weight of the car would not be over 4,000 pounds and its price would be somewhere around \$5,000.

F. E. D.

Haverhill, Mass.

### Co-operative Manufacture

EDITOR THE AUTOMOBILE:

Many of your readers have described their ideal cars for 1912. From the size of the cars desired, most of the descriptions seem to come from married men with large families.

My needs would be better filled by a small car—a dependable runabout. I prefer a two-cylinder car to many of the 'fours' which have a stroke barely in the plurality of inches. Many experts have spoken in favor of the two-cylinder engine for cars of 20 horsepower and below. Therefore, let the engine have two cylinders, opposed, under the hood, with a bore of 4 3/4 inches and a 5-inch stroke. This would give full 18 to 20 horsepower, if properly constructed.

The hood should be of the Renault pattern, well raised. The transmission should have three speeds, of course, and selective; geared three to one, but with the low so low that the engine would pull a full 30 horsepower on hills. The clutch should be of the multiple-disc type with enough plates to avoid grabbing, and the wheels should be 34 inches in diameter with 3 1/2-inch tires. I would put an 18-gallon gasoline tank under the seat, and make a large tight-closing carrying space in the rear.

This runabout would be primarily for two passengers, but the seat should be made undivided and large enough for three in a pinch. The tool box should be put on sturdy running boards, and enough of the inner side of the front mudguards should be clipped out to give the driver a clear view of the front rims. Mud will not spray through this aperture to any extent, and it is a great convenience to see just exactly where you are driving the front wheels in tight places.

A manufacturer making such a runabout of good materials with the best grade of workmanship, selling it direct to buyers and giving 5 per cent. off on club orders of three or four, and 7 per cent. off on those of five or more, ought to make a good profit at \$500 for each car. In one active season, without exaggerating the intended output, the maker ought to sell 15,000 of these machines. The price could then be lowered 20 per cent. and at least 20,000 more such runabouts sold with but little advertising.

The apples of profit in the co-operative field of automobile making are as ready for plucking as was the over-ripe fruit in the garden of the Hesperides.

Seattle, Wash.

S. ROSS PARKER.



# Automobile Metallurgy Made Easy

By E. F. LAKE

## Part IV Torsional Strains



HERE are many parts of an automobile which are submitted to torsional strains, that is, twisting strains. While it is possible to get from the tensile strength, elongation, etc., an idea of the torsional strains a metal will stand, these do not tell the whole story. Steel might show a good resistance against being pulled apart and thus have a high tensile strength, and yet not be tough enough to withstand high twisting or torsional strains. On the other hand, a steel might only have a medium tensile strength and still withstand very high torsional strains.

In the tensile testing machine the molecules of the mass are separated by being pulled away from one another in a straight line, while in the torsional strains these molecules must slide past one another until their cohesive force has been destroyed enough for the metal to break. Cylindrical pieces A, B, C and D in Fig. 1, show the manner in which torsional strains affect materials. The fine lines in A outline a plane, from the center to the circumference of a round bar before it is twisted or torsional strains are applied. Piece B shows the position this same plane occupies when the bar has been twisted. Piece C shows an elementary sector of this same round bar before being twisted, and D shows it after it has been twisted. These latter two illustrate the manner in which the particles of the mass must slide by one another when a material is given a torsional strain. Toughness, hardness, ductility, density and cohesion are all factors that affect the torsional strains that materials will withstand.

Many of the most vital parts of an automobile are submitted to these torsional strains and hence torsion tests are of nearly as much importance as those for tensile strength, elastic limit, elongation and reduction of area. They are made on a different machine, however, and consequently many rely on the tensile test to indicate what the metals will stand. The crankshaft of the engine, in particular, is given a sudden torsional strain every time an explosion occurs in one of the engine cylinders and when a car is moving this occurs almost continually. From there the torsional strain is transmitted to the different shafts in the gearbox. It is then transmitted through the

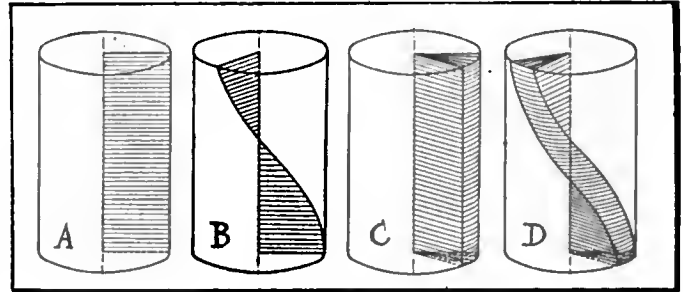

Fig. 1—How torsional strains affect materials

universal joint to the driving shafts and mechanism of the rear axle. Where the chain and sprocket are used for transmitting the power to the rear wheels the strain may follow a little different course but the principle is the same and it affects nearly all driving parts between the crankshaft of the engine and the rear wheels.

The camshaft is submitted to slight torsional strains as well as all other parts that revolve. When driving a car over a rough road, the front axle is also submitted to torsional strains. Here, however, the strains alternate back and forth in opposite directions, an effect which is not produced in any of the revolving shafts of the mechanism. True, the backing up of a car causes torsional strains to be delivered to the driving parts in an opposite direction to that transmitted when it is being driven ahead. This, however, is not the sudden change in direction that takes place in the front axle and, consequently, can be ignored. Likewise, the frame is submitted to this twisting strain that suddenly changes in direction.

As these torsional strains affect all of the important moving parts of a car, as well as the frame, front axle, etc., they are factors that should not be ignored in the testing of materials and the tensile strength should not be taken as an indication of a material's resistance to torsional strains. The torsional resistance varies greatly in the various metals used. Cast iron is a hard, brittle metal and resists torsional strains very poorly. Aluminum, on the other hand, is comparatively soft and plastic and this also resists only slight torsional strains. Both of these metals however, are lacking in toughness, density and cohesive force, which may account for their low torsion.

Brass will show a higher torsion than either of these but yet is not a metal that is high in torsional strength and hence should not be submitted to such strains. Some of the bronzes are very tough and will withstand very high torsional strains. Notable examples of these are manganese and tobin bronze.



Fig. 2.—Specimens of automobile front axles after the torsion test has been applied

Steel has a higher resistance to torsional strains than any of the other metals and, consequently, it is used for the important parts that have to withstand such strains. There is, however, a great difference in steels and some do not have as great a torsional strength as the bronzes mentioned. The two specimens of front axles that are shown in Fig. 2 give a good illustration of this.

The lower axle was made from low carbon steel and when a torsional strain of 15,700 pounds per square inch was applied it twisted through four and one-half complete revolutions in its length of 24 1-2 inches; the elastic limit of torsion occurred at 3,500 inch pounds.

The upper axle was made from one of the special alloy steels often used in automobile construction and when a torsional strain of 30,700 pounds per square inch was applied, it only twisted through three and one-half complete revolutions in the same 24 1-2 inches of length. The elastic limit of torsion in this latter axle was not reached until 7,540 inch pounds had been applied. It will thus be seen that the high grade alloy steel had double the torsional properties possessed by the low carbon steel.

Like the other strength properties, torsion is greatly affected by heat-treating steel. If steel is heated to a high temperature and suddenly quenched in water or brine, its toughness is gone and it is very brittle. Its resistance to torsion therefore would be very low. On the other hand, if this hardness and its resultant brittleness were reduced by tempering the steel, that is, reheating it to comparatively low temperatures and then cooling it, its torsional resistance will be greatly increased. Some of the alloy steels, such as nickel chrome, will give very high torsional resistance figures when they have been properly heat-treated.

**A REAL RUBBER SOLUTION**—In the *Moniteur Scientifique* for September F. Ahrens indicates the means for obtaining true and highly adhesive solutions of rubber. In the so-called solutions of rubber in benzine, gasoline, benzol and toluene the rubber is only swollen, and merely a colloidal suspension is produced which, thrown on a filter, immediately separates into its two constituents, *viz.*, the colloid and the fluid which causes it to swell. By employing raw Para rubber and operating under certain conditions which the author indicates solutions which are very binding and of high viscosity are obtained, and the rubber conserves its original structure almost completely. But if it is triturated the solution becomes much more subject to oxidation and loses some of its adhesive property.

By employing amyl acetate as a solvent and treating very thin slices of cleaned and skinned Para, the author has succeeded in obtaining true solutions which will pass through an ordinary paper filter without assistance from suction or pressure, though very slowly. The filtered fluid is of amber color and its fluidity it like that of castor oil.—From *Le Génie Civil*, November 25.

**OXY-GASOLINE FLAME FOR WELDING AND SOLDERING**—According to a somewhat indefinite report, gasoline, benzol, kerosene or alcohol may handily be used in the place of acetylene gas for autogenous welding or for soft soldering. To this end, the oxygen generator is simply connected by pipe or hose with a tank containing one of the fluids mentioned, and from it the gas mixture is piped under pressure to the burner, where, the report says, it is heated by means of a small lamp. The flame is rather large, it is admitted, but the purity of the gas excludes all clogging of the nozzle, while the fuel is more universally obtainable than acetylene or hydrogen and considerably cheaper.—From *Metal-Technik*, October 7.

## Calendar of Coming Events

### Shows

- Dec. 30-Jan. 6.....Buffalo, N. Y., Annual Show, Seventy-fourth Regiment Armory, Buffalo Automobile Trade Association.
- Jan. 2-11.....New York City, Hotel Astor, Importers' Salon.
- Jan. 6-13.....New York City, Madison Square Garden, Twelfth Annual Show, Pleasure Car Division, Automobile Board of Trade.
- Jan. 6-20.....New York City, Madison Square Garden, Annual Show, Motor and Accessory Manufacturers.
- Jan. 10-17.....New York City, Grand Central Palace, Twelfth Annual Show, National Association of Automobile Manufacturers; also Motor and Accessory Manufacturers.
- Jan. 13-19.....Milwaukee, Wis., Auditorium, Fourth Annual Show, Milwaukee Automobile Dealers' Association.
- Jan. 13-27.....Philadelphia, Annual Show, First and Third Regiment Armories, Philadelphia Automobile Trade Association.
- Jan. 15-20.....New York City, Madison Square Garden, Twelfth Annual Show, Commercial Division, Automobile Board of Trade.
- Jan. 15-20.....Toledo, O., Annual Show, Terminal Building, Toledo Automobile Dealers' Association.
- Jan. 22-27.....Rochester, N. Y., Annual Show, State Armory, Rochester Automobile Dealers' Association.
- Jan. 22-27.....Detroit, Mich., Wayne Gardens, Eleventh Annual Show, Detroit Automobile Dealers' Association.
- Jan. 22-27.....Providence, R. I., Providence State Armory, Rhode Island Licensed Automobile Dealers' Association, Automobile and Accessories Show.
- Jan. 27-Feb. 10....Chicago Coliseum, Eleventh Annual Automobile Show under the auspices of the National Association of Automobile Manufacturers. Pleasure cars, first week. Commercial vehicles, second week.
- Jan. 27-Feb. 10....Pittsburgh, Pa., Sixth Annual Show, Automobile Dealers' Association of Pittsburgh, Inc. Pleasure cars, first week. Commercial vehicles, second week.
- Jan. 29-Feb. 3.....Scranton, Pa., 13th Regiment Armory, Second Annual Show.
- Feb. 1-7.....Washington, D. C., Annual Show, Convention Hall.
- Feb. 3-10.....Montreal, Canada, National Show, Drill Hall, Automobile Club of Canada.
- Feb. 5-17.....St. Louis, Mo., Coliseum, Annual Show, Pleasure cars, first week. Commercial vehicles, second week.
- Feb. 12-17.....Ottawa, Ont., Howick Hall, Annual Show, Ottawa Valley Motor Car Association.
- Feb. 12-17.....Kansas City, Mo., Annual Show, Combined Association of Motor Car Dealers.
- Feb. 14-17.....Grand Rapids, Mich., Third Annual Show.

- Feb. 17-24.....Pittsburgh, Pa., Second Annual Show, Exposition bldg., Pittsburgh Auto Show Association, Inc.
- Feb. 17-24.....Newark, N. J., Fifth Annual Automobile Show, New Jersey Automobile Exhibition Company, First Regiment Armory.
- Feb. 17-24.....Minneapolis, Minn., National Guard Armory and Coliseum, Annual Automobile Show, Minneapolis Automobile Show Association.
- Feb. 19-24.....Omaha, Neb., Seventh Annual Show, Auditorium, Omaha Automobile Show Association.
- Feb. 19-24.....Hartford, Conn., Annual Show, Automobile Club of Hartford, State Armory.
- Feb. 19-24.....Cincinnati, O., Annual Show, Music Hall, Cincinnati Automobile Dealers' Association.
- Feb. 20-24.....Binghamton, N. Y., State Armory, Third Annual Show, Automobile Dealers' Association.
- Feb. 20-28.....Baltimore, Md., Annual Show, Baltimore Automobile Dealers' Association.
- Feb. 21-24.....Louisville, Ky., Fifth Annual Show, First Regiment Armory, Louisville Automobile Dealers' Association.
- Feb. 21-28.....Toronto, Ont., Annual Show, The Armouries, Toronto Automobile Trade Association.
- Feb. 24-March 2...Brooklyn, N. Y., Twenty-third Regiment Armory, Annual Show, Brooklyn Motor Vehicle Dealers' Association.
- Feb. 26-Mar. 2....Elmira, N. Y., Second Annual Show, Elmira Automobile Club.
- Feb. 26-Mar. 2....Paterson, N. J., Annual Show, Fifth Regt. Armory, Paterson Automobile Trade Association.
- Feb. 28-Mar. 2....Davenport, Iowa, Annual Show, Davenport Automobile Association.
- March 2-9.....Boston, Mass., Tenth Annual Show, Boston Automobile Dealers' Association, Inc.
- March 4-9.....Denver, Col., Auditorium, Annual Show.
- March 4-9.....Denver, Col., Annual Show, Auditorium, Motor Field.
- March 6-9.....Tiffin, O., Second Annual Show, *The Advertiser*.
- March 12-16.....Syracuse, N. Y., Fourth Annual Show, State Armory, Syracuse Automobile Dealers' Association.

### Meetings, Etc.

- Dec. 20.....New York City, Waldorf-Astoria, Annual Banquet of the Automobile Club of America.
  - Jan. 18-20.....New York City, Annual Meeting of the Society of Automobile Engineers.
- Race Meets, Hill-Climbs, Etc.**
- Dec. 25-26.....Los Angeles, Cal., Track Races, Motordome.

# THE AUTOMOBILE

Vol. XXV

Thursday, December 14, 1911

No. 24

## THE CLASS JOURNAL COMPANY

H. M. SWETLAND, President

CONDE NAST, Vice-President and General Manager

E. M. COREY, Secretary and Treasurer

231-241 West 39th Street, New York City

Cable Address - - - - - Autoland, New York  
Long Distance Telephone - - - - - 2046 Bryant, New York

### SUBSCRIPTION RATES

United States and Mexico - - - - - One Year, \$3.00  
 Other Countries in Postal Union, including Canada - - - - - One Year, 5.00  
 To Subscribers—Do not send money by ordinary mail. Remit by Draft,  
 Post-Office or Express Money Order, or Register your letter.

Entered at New York, N. Y., as second-class matter.  
 The Automobile is a consolidation of The Automobile (monthly) and the Motor  
 Review (weekly), May, 1902, Dealer and Repairman (monthly), October, 1903,  
 and the Automobile Magazine (monthly), July, 1907.

## From Either Side

WHERE do we stand? Mr. A. writes and asks why American automobile builders do not wake up and do something; then comes a letter from Mr. B., who says that America is making greater progress in the art and design of the automobile than any foreign land. Both claim to be right. Mr. A. in defense of his claim points to the progress shown at the recent Olympia exhibition. England has adopted worm drive for touring cars; she has accepted the detachable wire wheel; she took up the sleeve-valve motor four years ago; she has brought out the piston-valve motor; she has recently marketed the new type of single-sleeve valve; she has gone in a wholesale way into four-speed gearboxes; she introduced to the world the fore-door body type; and for a couple of years has been pushing ahead in the development of carbureters, so that six-cylinder cars can average 24 miles per gallon of fuel between London and Edinburgh. This is quite a long and worthy list of achievements—a list that shows engineering and manufacturing activities. But what has Mr. B. to say? He points to the many things that American makers were doing four or five years ago, and which things Europe is just working at to-day. The supplementary coil spring to be used in conjunction with rear springs was brought out and used extensively on this side of the Atlantic over five years ago, and it is just having its innings abroad at present. In Paris one maker is getting more profit out of his factory for these springs than are several of the car builders out of their factories. Thanks to our poor roads we had to have them years ago in order to drive with any degree of comfort over country roads.

Take more important examples: Europe is to-day imitating America in the matter of unit construction of the motor and gearbox. For three or four years this tendency has been gaining ground very rapidly with American makers, and it shows many converts in Europe for next season, one of the most conspicuous being the pioneer Panhard. The American design in which the gearbox is formed as a unit with the rear axle is also

showing many gains, not a few of the leading builders—including Sheffield-Simplex, one of the finest engineering houses in England—using this construction for next year.

For several years it has been general in Europe to put one set of brakes on the rear wheel drums and to have the other set on the propeller shaft immediately in rear of the gearbox. During such time American makers were putting both sets on the rear axle. Now Europe has taken up the rear axle scheme and there is a virtual stampede towards it. While America was not the originator of the rear wheel double-brake idea, she was certainly its exponent, and demonstrated that it is correct.

But we must be fair and look at the other side of the picture: Europe was ahead of us on the non-poppet valve motor. Knight had to go to London to get recognition for his double-sleeve valve. He was a prophet without honor in his own land. He mounted into almost instantaneous fame abroad. Daimler, Mercedes, Panhard and Minerva gave him the open door and then the entire world was interested. There were more American engineers visiting Coventry than there were French, German or English. Europe took up the Knight motor and America rushed to get into the band wagon. This was Europe's inning. England set the pace in the lubrication field for motors. De Dion was the pioneer in the non-splash system that is gaining so many adherents to-day, and an American abroad introduced the trough system for oiling the lower connecting rod bearings. Mercedes and many of the other big concerns now interconnect the accelerator pedal and the throttle control with the motor lubrication system, so that when the throttle is opened more oil is fed. In America the users of the Knight type of motor for 1912 use the same system. It is a commendable one, and should be imitated. There are various ways of doing it: Panhard works it by a vacuum control from the mixing chamber of the carbureter, whereas others use the hinged trough as brought out by the Daimler people.

What is the end of the whole matter? There are scores of examples of good pioneering work on either side. It would seem that Europe has been the pioneer in more good things than America, but that America has been quicker to take up a good idea, and the makers in general have adopted it more readily than in Europe. In France and England many individual builders have brought out excellent designs, but it has taken years for the other makers to adopt them, whereas in America imitation is much quicker and vastly more general. Europe has done much experimenting along lines that have not proven desirable for one reason or another. The front-wheel brake is an example of this. So with the matter of side-sway devices to prevent the rear end of the body swaying out too far in taking a curve at speed. It is well to have all these problems settled, and while Europe has been settling hers America has been doing her part. Both are working towards the ultimate; one is of assistance to the other. Europe carried the burden almost entirely at the start, but America is doing nobly at the present time. In America the big problem has been production; in Europe this phase of the situation has not been paramount excepting in a few cases. The Society of Automobile Engineers in America will do and is doing much to develop the pioneering spirit on this side of the Atlantic.

# The Legal Field—Allen Suit Proceeds

THE various bumps suffered by the Allen-Kingston Motor Car Co., in 1907, came under the spotlight when the suit of that concern against the Consolidated National Bank and three bank directors came up on the calendar of the New York Supreme Court last week. One of the material witnesses of the plaintiff company is in California and the court was asked for permission to take his testimony by commission.

The facts in the case are that Walter C. Allen, of New York, entered into a contract with the Kingston Motor Co. to build 100 cars. The undertaking of the Kingston company was guaranteed by E. R. and O. F. Thomas, New York bankers, but after six of the automobiles had been practically completed, the company announced that its resources were exhausted, including \$16,500 put up by Allen as a deposit. The Thomas guarantee was worded so as to expire if the contract should be assumed by some manufacturing company satisfactory to Allen.

After some rather protracted negotiations, the contract was turned over to the New York Car & Truck Co., Allen claiming that the financing of the manufacturing project had been agreed to by the bankers. He turned back to the company the six unfinished cars and paid in \$8,500 more in cash.

In March, 1906, the New York Car & Truck Co. failed and Allen sued the bank and bankers, charging that misrepresentations had been made to get him to turn over the contract to the insolvent company. On the original trial a verdict for \$28,463 was given in his favor. This was carried to the appellate division and was reversed and a new trial has been ordered. The first act in the new trial was the granting of an order to take the testimony of a California witness by commission.

It is doubtful whether the full hearing of this case can be had until late in the winter. The original trial occupied several days and the record taken at that time is more than 1,000 pages of closely printed text.

## Koehler Suit Against E-M-F Halted

The withdrawal of a juror in the suit for \$100,000 damages brought by the H. J. Koehler Co. against the E-M-F Co., halted the proceedings abruptly in that case and will probably result in a delay of several months. The case was called for trial in Part 14 of the Supreme Court on Wednesday and had proceeded but a short time when it was discovered that a bill of complaint would have to be amended to cover a new state of facts that developed. Paul Bonyng, representing the plaintiff company, moved for the withdrawal of a juror and leave to amend the petition.

The suit is based upon alleged failure to conform to the terms of a contract that existed between Koehler and the company in 1908-1909 to represent it in the metropolitan field. The contract called for the delivery of 1,000 cars to Koehler and he contends that only 546 automobiles were so delivered. The company maintains that Koehler's contract was modified by written communications and that it holds a release from the plaintiff against liability arising out of the contract.

## Rajah Company Wins Action

The International Automobile League, of Buffalo, and its president (Arthur C. Bidwell) have been adjudged guilty of contempt in violating the terms of an injunction issued against them on behalf of the Rajah Auto Supply Co. There were four counts against the league and one against Bidwell. Fines and costs were imposed.

About a year ago the Rajah company sued out an injunction against the league on the ground that it was selling a porcelain plug similar in exterior appearance to the one of the Rajah company. The injunction included Bidwell in its prohibitions.

The action for contempt was begun quite recently and was decided by Judge Lambert last week.

## Another Klaxon Suit Filed

Another action has been filed by the Lovell-McConnell Manufacturing Co., of Newark, N. J., against the American Ever-Ready Co., involving the Klaxon patents. The first suit was filed December 2 in the United States Circuit Court, Southern District of New York, and is based upon alleged unfair competition and imitation of the three basic patents covering the Klaxon warning devices.

The second suit is formulated upon two of the detail patents controlled by the plaintiff company and a third suit, covering the design patents, is being prepared for filing.

The bill prays for an injunction, damages and an accounting.

## National Wins Its Axle Suit

When the suit of Lindsay & Harmon against the National Motor Vehicle Co. was dismissed by the United States Circuit Court at Indianapolis, one of the really momentous litigations of the year in the automobile world was settled. The case involved an attempt to establish the exclusive right to manufacture floating axles for the licensee of the complainants, the Timken Axle Co. of Detroit. The case has been pending since 1905 and was argued before Judge Anderson last June. It was set for re-argument in November, but when the matter came up the complainants moved to dismiss it voluntarily.

## T. C. A. Double Transcontinental Trip

WASHINGTON, D. C., Dec. 9—President Taft to-day gave an audience to Thomas W. Wilby, pathfinder of the Touring Club of America, and Mrs. Wilby, who arrived in Washington yesterday on the final stage of a double transcontinental tour, which started from New York the last week in August. Mr. and Mrs. Wilby were presented to the President by Leroy Mark, manager of the southeastern department of the Touring Club of America.

President Taft manifested great interest in Mr. Wilby's account of the trip across the continent and back. Commenting on the great influences at work to improve the country's highways, the President said good roads stood for the social and moral uplift of the nation. Later in the day Mr. and Mrs. Wilby were introduced to Speaker Champ Clark and a number of Congressional leaders, who evinced lively interest in the trip now nearing completion. An Ohio car, driven by Fred Clark, is being used by Pathfinder Wilby. The party will leave for New York Monday, arriving there about the middle of the week.

Mr. Wilby and his party reached New York Wednesday completing the great circuit of the country, including 11,000 miles of automobile touring. Upon arrival in New York the party were received at the headquarters of the Touring Club of America, Broadway and Seventy-sixth street. After an informal reception the tourists and escort proceeded to the Holland House, where an elaborate luncheon was served.



## NEWS of the WEEK CONDENSED

New England KisselKar auto bus for regular winter service between White Plains and Port Chester, N. Y.

**MILWAUKEE, WIS.**—Isaac G. Hickman, president of the Hickman-Lauson-Diener Co., state agent for the Ford, was re-elected president of the Milwaukee Automobile Dealers' Association at the annual meeting. Emil Estberg, representative of the Pope-Hartford and Woods and Waverly electrics, was elected vice-president; A. E. Haffauf, of the American Automobile Co., Pierce-Arrow agent, secretary, and August A. Jonas, Cadillac and Peerless, treasurer.

**PORTLAND, ME.**—G. A. Blanchard has been appointed the new Selden agent in this city.

**PORT ANGELES, WASH.**—J. C. Leadbetter now has the handling of the Mitchell line here.

**SAN DIEGO, CAL.**—The U. S. Grant Hotel Garage has taken the agency for the National 40.

**DEFIANCE, O.**—H. E. Throne has sold the repair department of the Jefferson Garage to C. F. Miller.

**NEW HAVEN, CONN.**—The White Motor Company has taken the agency for the Reo for this vicinity.

**TRENTON, N. J.**—The Trenton Taxicab Company has changed its name to the Trenton House Garage.

**CHARLESTON, S. C.**—The Charleston Motor Sales Co. has taken the agency for the Ford car in this territory.

**ROCK ISLAND, ILL.**—The Totten Automobile & Supply Company has taken the Lozier and Abbott-Detroit agencies.

**PORT HURON, MICH.**—The Havers Motor Car Co., of this city, has increased its capital stock from \$60,000 to \$200,000.

**SYRACUSE, N. Y.**—The W. King Smith Co. has now taken possession of its new garage at No. 106 North Clinton street.

**COLUMBUS, O.**—The Front Street Garage & Auto Repair Co., 286 North Front street, has taken the agency for Grabowsky trucks.

**SYRACUSE, N. Y.**—The local agency for the Stoddard-Dayton has added the Gramm truck to its line. A. W. Zimbrich is manager.

**MONTREAL, QUE.**—The International Car Agency Co., 855 St. Catherine street, West, has been appointed local agent for the Interstate car.

**DYERSVILLE, IA.**—J. Friedman, of this city, has contracted to handle the Continental, Kisselkar, E. M. F. and Flanders lines for 1912.

**PEORIA, ILL.**—The Peoria Auto Co. is now handling the Waverly Electric, for which the Bourdeaux company was the original agency.

**CLINTON, ONT.**—The Clinton Motor Car Co., Ltd., is the title of a newly incorporated company in this city with a share capital of \$100,000.

**LOS ANGELES, CAL.**—The Studebaker Company's Southern California branch is established in its new home at 1620 to 1624 East Seventh street.

**TACOMA, WASH.**—J. A. Croston and A. E. Sweet, proprietors of the Sixth Avenue Garage, have secured the agency for the Buick car in Tacoma.

**PEORIA, ILL.**—The J. C. Warner auto agency has signed a contract with the Metz runabout company to handle the Metz 22 during the coming year.

**NEW YORK CITY.**—The H. W. Bell Company, agent for the Stanley steam car in New York and vicinity, has removed to 247 West Fifty-seventh street.

**OMAHA, NEB.**—The Lininger Implement Co. closed a contract with E. G. Minnix, of Sioux Falls, S. D., for 125 R. C. H. and Oakland cars for that territory.

**BOSTON, MASS.**—H. R. Smith, formerly district manager for the Metzger Motor Car Co., is now traveling salesman for the J. S. Harrington Co. in New England.

**ATLANTA, GA.**—W. T. Downing has prepared plans for a five-story, reinforced concrete building to be erected for the Buick Motor Car Co. at a cost of \$50,000.

**NEW YORK CITY.**—The Gallagher-Tompkins Co., of 1876 Broadway, is the newly appointed metropolitan agent for the Selden Motor Vehicle Co., of Rochester, N. Y.

**BOSTON, MASS.**—B. W. Shaw, formerly in charge of the Park Square Auto Station, has taken charge of the service station of the Empire motor car agency in this city.

**BOSTON, MASS.**—General sales manager Baker, of the American Motor Car Company, has been in Boston aiding manager Doane of the Essex Automobile Company, agent for the American car, in getting settled in the new salesrooms on Boylston street.

**BOSTON, MASS.**—In the Middlesex County Court last week fifteen suits, aggregating \$88,500, were filed against automobilists. The largest is one of \$30,000 against George F. Schraft, a wealthy confectioner of Newtonville, whose car killed Felix Chesnovich in September.



**BUYRUS, O.**—Wilbur S. White has taken the agency for the Marion car.

**WASHINGTON, D. C.**—Earle & Allen have taken the agency for the R. C. H. car.

**STERLING, ILL.**—M. R. Thackaberry, local agent for the Cole car, has moved from 316 First street to 601 West Third street.

**BOSTON, MASS.**—J. H. Crocker is the latest addition to the sales-force of the New England branch of the Marquette.

**INDIANAPOLIS, IND.**—W. T. Hutchinson, of Hempstead, L. I., and Winthrop Pier, El Centro, Cal., have been appointed agents for the Cole car.

**WASHINGTON, D. C.**—Earle & Allen, agents for the R. C. H. and Hupp-Yeats, have removed from 1612 Fourteenth street, N. W., to larger quarters at 1214 Eighteenth street.

**CAIRO, ILL.**—Glenn Tracy has purchased the automobile sales business of Wood, Gorham & Wood, of this city, and will handle the Ford car in the eastern part of Henry County.

**AUBURN, N. Y.**—George H. Leonard has secured the contract to sell Franklin automobiles in this territory under the supervision of the Syracuse branch of the Franklin Automobile Co.

**NEW YORK CITY**—The Colonial Sales Co. has taken the distributing agency for the G. J. G. car. The company is located in the Colonial building at Broadway and Sixty-sixth street.

**WASHINGTON, D. C.**—W. Elkins Reed has opened an automobile supply house at 1218 Connecticut avenue. T. Lamar Jackson, agent for the Stevens-Duryea, has leased a portion of the store.

**NEW YORK CITY**—Chas. E. Riess & Co., general distributors of the Marion car and the American-Marion Sales Co., have moved into their new quarters at Broadway and Sixty-third street.

**WAKEFIELD, MASS.**—At the fall town meeting the recommendation of a committee that the town purchase a motor fire truck was accepted and \$3,800 was appropriated for the purpose.

**MOLINE, ILL.**—Jack Stickney, of the Velie Motor Vehicle Co., has bought a Bleriot monoplane and will take up aviation in the spring. He is now experimenting with a motor for the machine.

**SEATTLE, WASH.**—Organizing in this city recently the Motor Distributing Co. will hereafter handle the Lozier car. T. A. Davis is president and treasurer and T. G. Young secretary and manager.

**BOSTON, MASS.**—The J. S. Harrington Company, agent for the Everitt car, has appointed J. H. Burkhard traveling inspector. Mr. Burkhard was formerly in charge of the Everitt service station.

**SYRACUSE, N. Y.**—George E. Messer, manager of the Syracuse branch of the

Franklin Automobile Co., has resigned to become sales manager for F. W. Bird & Son, paper manufacturers, of Boston, Mass. Mr. Messer will have charge of the Western territory.

**INDIANAPOLIS, IND.**—The following Cole agents have new salesrooms and service stations: E. E. Loving Auto Co., Memphis, Tenn.; Imperial Motor car Co., Cincinnati, O., and J. E. Morehouse, Milwaukee, Wis.

**OKLAHOMA CITY, OKLA.**—The Penn Motor Car Company, of Pittsburgh, Pa., has designated Oklahoma City as its southwestern distributing point for the Penn 30 and the Penn 40 and light delivery trucks.

**OKLAHOMA CITY, OKLA.**—According to the annual report of the state auditor, made from the certified report of the county tax boards, there are 3,459 automobiles in the State. A total value of \$2,648,845 is given.

**ST. PAUL, MINN.**—The new automobile tags for this state are of aluminum in which the black lettering is sunk. Under the new law these tags will be good until the end of 1914 instead of for only one year.

**COLUMBUS, O.**—The Union Sales Co. has appointed the following agents for the Union 25: Crowe Motor Car Co., Minneapolis, Minn.; Marx Bros., Milwaukee, Wis., and McNabb Garage, Newport, Tenn.

**CHICAGO, ILL.**—F. H. Quick, formerly with the Gibson Auto Company, of Indianapolis, Ind., and United Motors Indianapolis Company, has joined the sales force of the Findeisen & Kropf Manufacturing Company.

**JANESVILLE, WIS.**—The Sykes & Davis Garage has passed into the hands of the Janesville Auto Company, a new \$10,000 corporation formed here to handle the Flanders, E. M. F. and Overland lines in Rock County.

**MILWAUKEE, WIS.**—The report of the building commissioner of Milwaukee from 1896 to 1910, just issued, shows that during the year 1910 there were constructed in Milwaukee eighty garage buildings, representing an investment of \$107,350. The record for 1911 will show a considerable gain over these figures.

**CINCINNATI, O.**—H. E. Taylor has resigned his position with the Automobile Supply Company of Chicago to join the sales force of the Olds-Oakland Motor Company. Mr. Taylor will have charge of the local retail business.

**AKRON, O.**—The Swinehart Tire & Rubber Co., this city, has under consideration plans for a large addition to the plant on North Howard street. The new building will be 50 by 200 feet and will be built just west of the present plant.

**MONTREAL, QUE.**—John Wells, formerly manager of the tire department of the Canadian Rubber Co., of this city, has resigned to take the position of sales manager of the P. Gadbois Co., representative for the Cole and E-M-F in eastern Canada.

**DETROIT, MICH.**—The Elmore Automobile Company, of this city, is now occupying its handsome new home at 754-756 Woodward avenue. The building, which is two stories in height, is of brick and concrete and is furnished with large show windows. M. A. Young is president of the company, which handles the Elmore cars and the Waverley Electrics.

**CLEVELAND, O.**—The Baker Motor Vehicle Company recently held a convention of its commercial car salesmen at the factory. Representatives were present from various parts of the country, including New York, Boston, Chicago, Buffalo and Newark. Salesmanship, factory methods and the company's product were studied for three days. The convention ended with a banquet at the Hollenden.



Convention of Baker commercial car salesmen at the factory



President Taft in a KesselKar at Huron, S. D., during recent Western trip

**GREEN BAY, WIS.**—Tooen & Barlaine are erecting a \$5,000 garage and sales-office building at George and Wisconsin streets.

**MILWAUKEE, WIS.**—J. M. Peil, of Racine, Wis., has been appointed manager of the local Mitchell branch to succeed F. P. Wilkins.

**OAKLAND, CAL.**—Curtis G. Heckenlively, of this city, has been appointed Pacific Coast distributor for the Universal Tire Protector Co., of Angola, Ind.

**TORONTO, ONT.**—The Cutting Motor Sales Co. of Canada, 76 Adelaide street, has been appointed wholesale distributor for Canada of the Cutting car and is busy placing agencies in large Canadian cities.

**SYRACUSE, N. Y.**—R. W. Sherman has resigned from the publicity department of the Franklin Automobile Co. and will devote his time to special writing in connection with automobile trade publications and newspapers.

**MILWAUKEE, WIS.**—The Jos. Obernberger Co., 126 Ferry street, has been appointed local agent for the Monitor commercial car, manufactured by the Monitor Automobile Works, of Janesville, Wis., formerly of Chicago.

**NEW YORK CITY**—New salesrooms have been opened by the Ajax-Grieb Rubber Co. for the sale of Ajax tires in Detroit and Denver. In the Michigan city a move has been made to 507 Woodward avenue, from 745 Woodward avenue.

**DETROIT, MICH.**—P. S. Beamer, who has been associated with President Everitt of the Metzger Motor Car Co. for a long period, has been made general auditor of that company and will have entire charge of all accounting and similar work.

**ROCHESTER, N. Y.**—The Selden Co. has opened a new salesroom at No. 119 East avenue. This is a branch of the factory used for sales purposes only, as the repair department is still maintained at the factory. W. C. Barry, Jr., is in charge.

**ADRIAN, MICH.**—The following agents have been appointed by the Lion Motor Car Co. of this city, to handle its 1912 line: Reliance Auto Co., San Francisco, Cal.; F. W. Hull, Boston, Mass., and the Joseph B. Deibler Motor Car Co., Chicago, Ill.

**SHEBOYGAN, WIS.**—August H. Prange, dealer in motor cars and farm machinery at Potter, Wis., has disposed of his interests in that city to Piepenburg & Reichert, of Reedsville, Wis., and will engage in the automobile business in Sheboygan.

**TORONTO, ONT.**—The Wolseley Tool & Motor Car Co., Ltd., has opened a Canadian branch here and is at present in a temporary office at 49 Wellington street, East, pending the erection of its new garage and salesroom at 81 Avenue road.

**WACO, TEX.**—William Amthor has retired from the firm of the Marion Auto Company. He sold his interest in the business to Grim Brothers, who will conduct business under the name Marion Motor Company at the same location, 700 Austin avenue.

**WAUKESHA, WIS.**—The Waukesha Motor Co., with 100 employees, has elected to come within the provisions of the new Wisconsin industrial insurance or workmen's compensation act, which was declared constitutional by the state supreme court several days ago.

**MILWAUKEE, WIS.**—The Kopmeier Motor Car Co., 375-389 Summit avenue, agent for the Fiat, Chalmers and Detroit Electric, has placed in service a 150-horsepower gas engine as additional equipment for the production of current for charging electric vehicles.

**DETROIT, MICH.**—George Main, formerly assistant traffic manager at the Chalmers plant, has been appointed traffic manager at the Metzger Motor Car Co. plant. Mr. Main has been connected with the traffic service for many years and is regarded as an expert in his line.

**DETROIT, MICH.**—George B. Pratt, for-

merly sales manager of the Dean Electric Company, of Elyria, O., has joined the sales force of the Anderson Electric Car Company. Mr. Pratt will have charge of sales in Ohio and in part of New York and Pennsylvania.

**CHICAGO, ILL.**—F. W. Grubb, of the Fulton & Grubb Co., manufacturers' agents, has severed his active connection with that company to accept the position of manager for the Excelsior General Supplies Co., 1436-1438 Michigan avenue. Mr. Grubb retains his financial holding in the Fulton & Grubb Co.

**PEORIA, ILL.**—On December 15 Braren Brothers, proprietors of the Turnbull agency and garage here, will commence handling the Flanders electric and White gasoline cars. They have also contracted for the agency for the Moon car, previously held by the Reliance Motor Car Co., of this city.

**SALEM, ORE.**—The automobile department of the Secretary of State's office recently received 6,000 numbers or 12,000 tags, weighing over 7,000 pounds, for use in registering automobiles during 1912. In addition, 2,000 chauffeurs' badges have been ordered. The number tags, which are issued in duplicate, have black figures against a green background.

**SEATTLE, WASH.**—The largest building permit issued in Seattle recently was issued to Olaf Olson, providing for the immediate erection of a two-story class A garage designed for four stories and covering a ground space 80 by 120 and 40 by 40 feet. The garage will be located at 1205-1211 East Pine street and will cost \$28,000.

**SYRACUSE, N. Y.**—B. J. Lane, of The Lane Auto Association, has taken over the management of The Syracuse Regal Co. and will act as the distributor of the 1912 Regal line as well as the KlineKar. Both The Syracuse Regal Co. and The Lane Automobile Association will have headquarters at No. 1205 West Genesee street.

**TOLEDO, O.**—The board of review is having a list made of all automobiles owned in the city as shown by the state license records for the purpose of enforcing the payment of taxes on machines, many of which have heretofore escaped taxation. According to the president of the board only about one-half of the automobiles owned in Toledo were returned for taxation last year.

**DETROIT, MICH.**—Charles W. Price, president of the Electrical Review Publishing Co., announces the purchase of *Electrocrafter*, an electrical journal largely devoted to electrical contracting and electrical supplies. Three electrical journals, the *Electrical Review*, the *Western Electrician* and *Electrocrafter*, will, after January 1, appear as one weekly publication with main offices in Chicago and branch offices in New York and London.

**PITTSBURGH, PA.**—The Pittsburgh Interstate Co. will handle the Stutz and Warren cars during the coming year.

**BOSTON, MASS.**—Chief engineer Wicks of the H. H. Franklin Co. has been spending several days at the Gray & Davis lamp factory going over details of equipment for automobiles.

**PORT HURON, MICH.**—Mr. B. F. Blaney, formerly general sales agent for the Johnson Service Co. of Milwaukee, has taken the position of sales manager for the Havers Motor Car Co.

**SAN FRANCISCO, CAL.**—The C. & F. Motor Car Co., has opened a salesroom at 436 Van Ness avenue, and will handle the Stutz car, manufactured by the Ideal Motor Car Co., of Indianapolis.

**BOSTON, MASS.**—John Cooper, formerly manager of the New England branch of the Ajax-Greib Rubber Co., has returned to the tire industry and is now representing the Endurance Tire & Rubber Co., in this territory.

**INDIANAPOLIS, IND.**—Paul P. Willis has been appointed advertising manager for the National Motor Vehicle Co. Mr. Willis was formerly automobile editor of *The Indianapolis Star*. He is secretary of the Hoosier Motor Club.

**BUCYRUS, O.**—The Seagraves Co. of Columbus, O., delivered to the fire department of Bucyrus, O., a new auto fire truck. The engine is of 80 horsepower and carries 1,200 feet of hose as well as ladders and chemical appliances.

**INDIANAPOLIS, IND.**—The recently organized Merchants' Auto Co. of Indianapolis has taken over the Delaware Garage at 214 North Delaware street and the new Colonnade Garage at 9 East Pratt street. E. Frank Brown has recently become general manager of the company.

**COLUMBUS, O.**—*The Exhaust* is the name of a new monthly publication issued by the Columbus Automobile Club. Club news, notes of the good roads movement and other matters of interest to automobilists generally will be contained in the publication. Allen F. Koch is editor.

**COLUMBUS, O.**—The Cummins Auto Sales Co., of North Fourth street, has placed the following sub-agencies in Ohio territory; E. O. Fogle, automobile company, Cambridge, Elmore; D. S. Spangler, Thornville, Elmore; R. E. Wiidermuth Automobile Co., Pleasantville, Krit.

**COLUMBUS, O.**—The Hudson Sales Co., of North Fourth street, Columbus, O., has closed contracts for the following sub-agencies: J. R. Armstrong, Lima, Hudson; in Allen, Van Wert, Mercer and Auglaize counties; Walker & Son, Lancaster, American, in Fairfield, Pickaway, Ross and Fayette counties.

**INDIANAPOLIS, IND.**—A contract for the delivery of its papers to news-stands, de-

pots and sub-stations has been let by *The Indianapolis News* of Indianapolis, to the Central Transfer and Storage Co., of that city. The transfer company has purchased for the work five Mais trucks, four Premier trucks, one Overland truck and a Reo truck.

**BALTIMORE, MD.**—Announcement has been made by A. Maurice Eastwick and Robert F. Kaehler that the partnership of

the local branch of the Ford Auto Co., handling the Ford cars in Maryland and Virginia, has been dissolved. Mr. Eastwick will continue in charge of the local agency, which will also include the state of Maryland, while Mr. Kaehler will remain in charge of the Ford Auto Co., in Richmond, Va., as agent for the Ford Car in that city and the remainder of Virginia.

## Automobile Incorporations

### AUTOMOBILES AND PARTS

**BROOKLYN, N. Y.**—Prudence Motor Truck Co.; capital, \$100,000; to build freight automobiles. Incorporators: Herbert Cooper, Arthur Cooper, Alfred G. Leomans, Charles G. Diegest, Franklin C. Haven.

**CAMDEN, N. J.**—Penn Motor Car Co.; capital, \$500,000; to build motor cars. Incorporators: V. A. Murray, L. A. Myers, Doering Ballinger.

**MILWAUKEE, WIS.**—Wisconsin Auto Sales Co.; capital, \$20,000; to sell automobiles. Incorporators: George P. Hewitt, R. L. Anderson.

**NEW YORK CITY.**—New York Motor Works, Inc.; capital, \$70,000; to build automobiles and engines. Incorporators: M. L. Rogers, S. E. Roberson.

**NEW YORK CITY.**—Gurlitt-Brown-Davis Co.; capital, \$25,000; to make and sell motor vehicles. Incorporators: H. Gurlitt, David S. Davis, Jr., V. C. Bogardus.

**NEW YORK CITY.**—Detmar Auto Sales Co.; capital, \$20,000; to manufacture and sell automobiles and engines. Incorporators: John J. McLaran, F. B. Knowlton, Edward C. Inderlied.

**NEW YORK CITY.**—Wishart-Dayton Auto Truck Co.; capital, \$25,000; to manufacture automobiles. Incorporators: R. A. Inchi, S. E. Wishart, J. B. Smith.

**NEW YORK CITY.**—Parker Motor Wagon Co.; capital, \$10,000; to make and sell motor cars. Incorporators: Harry C. Cottfried, Drew McKenna, Chas. E. Wood.

**NEW YORK CITY.**—Mooer Auto Co.; capital, \$450,000; to make automobiles. Incorporators: E. J. Bosse, G. Leveene.

**NORTHAMPTON, PA.**—Siegfried Motor Car Co.; capital, \$10,000; to sell automobiles.

**PHILADELPHIA, PA.**—C. V. Stahl Motor Co.; capital, \$5,000; to sell motor cars.

**RICHMOND, VA.**—American Adjustable Wheel Co., Inc.; capital, \$100,000; to manufacture and sell adjustable automobile wheels. Incorporators: J. H. Pinner, J. C. Davis, R. H. Bruce.

**ROANOKE, VA.**—Roanoke Motor Car Co.; capital, \$25,000; to sell automobiles. Incorporators: Frank Welch, Sr., J. E. Shickle, Frank Welch, Jr.

**ROCHESTER, N. Y.**—Turk & Brown, Inc.; capital, \$10,000; to manufacture motor vehicles. Incorporators: Sophie H. Brown, Alfred H. Brown.

**SELMA, ALA.**—Central Alabama Motor Car Co., Inc.; capital, \$1,500. Incorporator: George H. Ashburn.

**SPRINGFIELD, ILL.**—Flexo Motor Co.; capital, \$30,000; to manufacture engines. Incorporators: Fred C. Miller, Wm. Wishart, Henry L. Smith.

**WILMINGTON, DEL.**—Williams Steel Wheel, Rim & Tire Co.; capital, \$1,000,000. Incorporator: William E. Williams.

**WINDSOR, ONT.**—Canadian Two-in-One Auto Co.; capital, \$200,000; to manufacture automobiles.

### AUTOMOBILES, GARAGES, ETC.

**BOSTON, MASS.**—Morsa-McDonald Co.; capital, \$15,000. Incorporators: John D. McDonald, John S. Moore, James H. Matthews.

**BUFFALO, N. Y.**—Carrall Tire Co.; capital, \$200,000; to make and sell rubber tires. Incorporators: John Gregson, George Cunliffe, J. E. Gregson.

**CHICAGO, ILL.**—F. A. L. Auto Co.; capital, \$2,500; to sell automobiles and operate a garage. Incorporators: Frederick C. Harbour, Clinton S. Limb, E. N. Lundberg.

**CHICAGO, ILL.**—National Automobile Owners' Alliance; capital, \$50,000; to make automobile accessories and parts. Incorporators: W. G. W. Ford, C. E. Becker, S. C. Miller.

**NASHVILLE, TENN.**—Hermitage Auto & Livery Co.; capital, \$3,000; to conduct a garage business. Incorporators: L. W. Jacobs, W. F. Jacobs, E. L. Holt, T. Allison, Harry A. Stokes.

**NEW YORK CITY.**—Batavia Co., of Pa.; capital, \$30,000; to make and sell tires for automobiles. Incorporators: Harry W. Newburger, Maxwell Lustig, D. Weiss.

**NEW YORK CITY.**—Cosmopolitan Motor Co.; capital, \$10,000; to conduct a garage business. Incorporators: John Devine, John J. Kirby, Albert G. Armento.

**NEW YORK CITY.**—H. & C. Garage; capital, \$10,000; to deal in, repair and store automobiles. Incorporators: Louis S. Hallowell, Herbert S. Cole, Arthur J. Cole.

**NEW YORK CITY.**—Security Motor Switch Co.; capital, \$10,000; to make motor switches and engine accessories. Incorporators: Albert Meadows, J. E. Cleveland, E. P. Beechler.

**NEW YORK CITY.**—Simpson Tire Fibre Co.; capital, \$100,000. Incorporators: S. L. Simpson, James D. May, Harry J. Dingemann.

**PERRY, OKLA.**—Automatic Motor Plow Co.; capital, \$200,000. Incorporators: A. A. Hullum, S. F. Rogers, H. F. Carmichaels.

**SAVANNAH, GA.**—Auto Sales & Livery Co.; capital, \$50,000; to conduct a garage business. Incorporators: H. W. Freeberg, E. J. Freeberg, G. R. Morehouse.



Harry Knight driving Cole 30-40 in which the officials rode in the Tour Around Georgia

# OF INTEREST *to the* INDUSTRY



Three-ton truck made by Transit Motor Car Company, Louisville, Ky.

**NEW MARKET, ONT.**—The Harding Motor Co. has decided to move from London, Ont., to this city.

**PITTSBURGH, PA.**—The Rotary Motor Co. has awarded the contract for an addition to its plant to the W. N. Kratzer Co.

**VICTORIA, TEX.**—The Texas Motor Car & Supply Company has let the contract for the erection of an addition to its machine shop.

**INDIANAPOLIS, IND.**—The International Metal Polish Company, of this city, has broken ground for a new factory to cost \$25,000.

**KEIL, WIS.**—The Keil Motor Car Company, organized by Fred Theissen and Phillip Juenheimer, will build a plant here to cost \$14,000.

**DETROIT, MICH.**—The Briggs-Detroit Co. has purchased a 2-acre factory site on Holbrook avenue from the Reinforced Concrete Pipe Co., of Jackson, Mich.

**ANDERSON, IND.**—Contracts have been awarded for the addition to the factory of the Remington Electric Company, which manufactures magneto ignition apparatus.

**SYRACUSE, N. Y.**—The Brown Company has commissioned local architects to prepare plans for a two-story brick factory here, of mill construction, 50 by 160 feet.

**VANCOUVER, B. C.**—The Central Auto Co., Franklin dealer in this territory, is rebuilding its garage, recently destroyed by fire. In its new quarters this concern will be in a better position than ever to handle business at this point.

**DETROIT, MICH.**—The Hupp Motor Company has awarded a contract for the erection of a plant at Windsor, Ont. The company has also taken out permits for the erection of a two-story brick factory to

cost \$65,000 at Mt. Elliot and Milwaukee avenues, in this city.

**NEW YORK CITY**—J. F. Hayes and W. S. Miller, formerly with the Rainier Motor Co., have incorporated a business under the name of Hayes & Miller Co. to paint and repair automobiles and to manufacture tops. The company is located at 317 West Forty-seventh street.

**BUFFALO, N. Y.**—George Ostendorf, formerly branch manager of the Franklin Automobile Co. in Buffalo, has purchased the branch and will hereafter conduct the business on a dealership basis under his own name. Mr. Ostendorf will retain his salesroom at No. 683 Main street.

**DETROIT, MICH.**—J. H. Newmark, who has been associated with the Oakland Motor Car Co., Pontiac, Mich., in the capacity of advertising manager, has been transferred to the office of the General Motors Co., Detroit, Mich., where he will assume a position as assistant to advertising manager Kurtz.

**HAMILTON, O.**—C. A. MacCordy, formerly connected with the advertising and publicity department of the H. H. Franklin Manufacturing Co., of Syracuse, N. Y., as superintendent of printing, has accepted a position with the Republican Publishing Co., catalogue makers of this city, as special automobile trade representative.

**LOS ANGELES, CAL.**—Ralph C. Hamlin, Franklin dealer in this territory, has just been informed by the Bosch Magneto Co., that he is entitled to the second prize, \$75.00, offered by that company to the driver of the second car finishing in the Los Angeles desert race, provided the car driven was equipped with a Bosch magneto.

**MILWAUKEE, WIS.**—The Milwaukee Auto

Specialty Company, recently incorporated with an authorized capital of \$75,000, has selected a site for its proposed new manufacturing and sales building at Seventh and Chestnut streets. The building will be five stories high, of reinforced concrete and steel construction, and will contain a large garage.

**CRANSTON, R. I.**—At the plant of the Maxwell Briscoe Motor Company, here, the rush of work has been so great that some of the departments were not able to keep up with the others, and as a result about 200 men were laid off temporarily. It is expected that the men will resume work again shortly, as the demand for the cars taxes the capacity of the plant.

**INDIANAPOLIS, IND.**—George Bott, formerly employed by the Nordyke and Marmon Co., is the inventor of a radiator-cover which is to be manufactured by the newly organized Antidam Manufacturing Co. in this city. The cover is made of pantasote and sheet metal, fitting closely to the radiator being fastened at the top over the radiator-cap and at the bottom by the crank.

**DETROIT, MICH.**—The McCord Manufacturing Co. has acquired the materials, patents and good will of the Precision Appliance Co. of Chicago, and will manufacture the Hill-Precision lubricators in connection with its former product. The company has added a cellular radiator to its line. An addition of 12,000 square feet has been made to the factory building and one of 4,000 square feet to the foundry.

**BOSTON, MASS.**—Otto A. Lawton, formerly connected with the Franklin Automobile Co. of Syracuse, N. Y., as manager of the branch in Boston, has purchased the branch and will conduct the business under the name of the Franklin Motor Car Company, of Boston. In connection with his dealership in Franklin cars Mr. Lawton will conduct a taxicab business with stands at the Hotel Somerset and Hotel Puritan.

**AKRON, O.**—A 50 per cent. increase in business in the past year was reported at the annual meeting of the Goodyear Tire & Rubber Co., held this week. Big buildings have been added, new salesmen and workmen taken on and the business of the company has had marked development along many lines. Forty branches have been established throughout the country and a new office building, the latest of a series of additions, is now under construction. The officers elected are: Frank A. Seiberling, president; Charles W. Seiberling, vice-president; G. M. Stadelman, secretary; F. H. Adams, treasurer, and P. W. Litchfield, factory manager.



# PATENTS GONE TO ISSUE

**CARBURETER**—In which the flow of fuel is regulated by a rotary valve.

5. The carbureter seen in Fig. 1 comprises a casing, in which is contained a mixing chamber for air and fuel, and a valve controlling air and fuel passage through the chamber in which a rotary fuel discharge valve is located. Valves are provided for admitting a variable supply of fuel to the pipe, and also means for effecting cooperative action of the rotary valve, admission valve mechanism and pipe, the valve mechanism being composed by a member with a recess in its face and open at its end to admit fuel thereto, a second member faced against the first and having an elongated port through it for registering with the recess mentioned, and a cap which is applied to and forms a chamber between itself and the second member. This member communicates with the discharge pipe, and one of the two members is stationary and the other rotary in the discharge pipe.

No. 1,010,714—To George J. Zisch, Newark, N. J. Granted December 5, 1911; filed May 12, 1910.

**LOW PRESSURE TIRE SIGNAL**—Indicates when inflation falls below a predetermined point.

This device (Fig. 2) consists of a body adapted to engage with a tire valve and having a central chamber; the body has an air inlet at its lower end and an air escape opening in its side, and in the chamber a partition is fixed between the openings thereof, the partition having a central opening. A disc is fixed in the chamber opposite the escape opening of the body and a portion of the disc is cut off. An adjustable plug is stationed in the upper end of the head, with a central rod passing through plug, disc and partition, and terminating below the latter. A valve and coiled spring are mounted on the rod.

No. 1,010,726—To Joseph M. Collins, Gorman, Tex. Granted December 5, 1911; filed January 31, 1911.

**FRICION CLUTCH**—In which two conical members engage a collar, thus providing connection between driving and driven unit.

In this clutch (Fig. 3) two conical members are mounted on a shaft in spaced relation and with their conical faces opposed. One of the two cones is fixed on the shaft and the other movable toward and away from the first member, and a collar on the shaft limits the movement of the movable member.

The hub portion of a wheel is shaped to fit between the two conical faces and to rotate on them. On the collar several cams are pivotally mounted, having cams which extend radially outward. Means are slidably mounted on the shaft, by which the cams may be shifted into or out of position for holding the movable member in gripping relation with the hub.

No. 1,011,040—To John J. Dennison, Chicago, Ill. Granted December 5, 1911; filed July 1, 1911.

**SPEEDOMETER**—Utilizing the transmission of motion through an air current produced in the apparatus.

2. This speedometer (Fig. 4) has a tight enclosure and a hollow cylindrical member held in spaced relation to the walls thereof, so as to form an unobstructed annular space. In this cylinder air currents are produced acting upon means responsive to the air currents, these means operating a device indicating the force of the currents.

No. 1,011,051—To Louis A. Greenleaf, Dorchester, Mass. Granted December 5, 1911; filed June 9, 1910.

**VEHICLE TOP FASTENER**—Apparatus for securing top holding members to the body of the automobile.

2. This patent refers to a canopy fastener comprising a supporting frame having pendent lugs, and latch casings carried by the seat in a car, bolts being contained by the casings. The bolts carry means for interlocking engagement with lugs supporting tubes for the casings mentioned. Rods extending through the tubes have crank arms for operating the bolts, and means are provided to oppose the rotation of the rods in one direction.

No. 1,010,968—William Spickernagle, Owensboro, Ky. Granted December 5, 1911; filed February 6, 1911.

**GAS ENGINE**—Of the double sleeve reciprocating type.

3. This patent covers an internal combustion engine, with a stationary working cylinder having inlet and exhaust ports and a pair of segmental or half-cylindrical slide valves with ports disposed around the cylinder. The slide valves may be operated to bring their ports to register with the inlet and exhaust ports in the cylinder on both up stroke and down stroke of the valves. A compression-retaining ring surrounds inlet and exhaust ports both circumferentially and vertically.

No. 1,010,566—To Arthur Alltree, Manchester, England. Granted December 5, 1911; filed January 19, 1910.

**INDICATING TAIL LAMP**—Lamp and frame for illuminating license-plate.

1. This patent relates to an outfit comprising a frame adapted to be secured to a vehicle; a horizontal base secured to the frame and suitable lamps carried at its end by the frame. On the base is stationed a box adapted to receive lights from the lamps and containing warning mechanism. Detachable chimneys for the lamps are adapted to secure the box to the frame.

No. 1,010,806—To Maurice S. Rosenfeld, New York. Granted December 5, 1911; filed August 26, 1911.

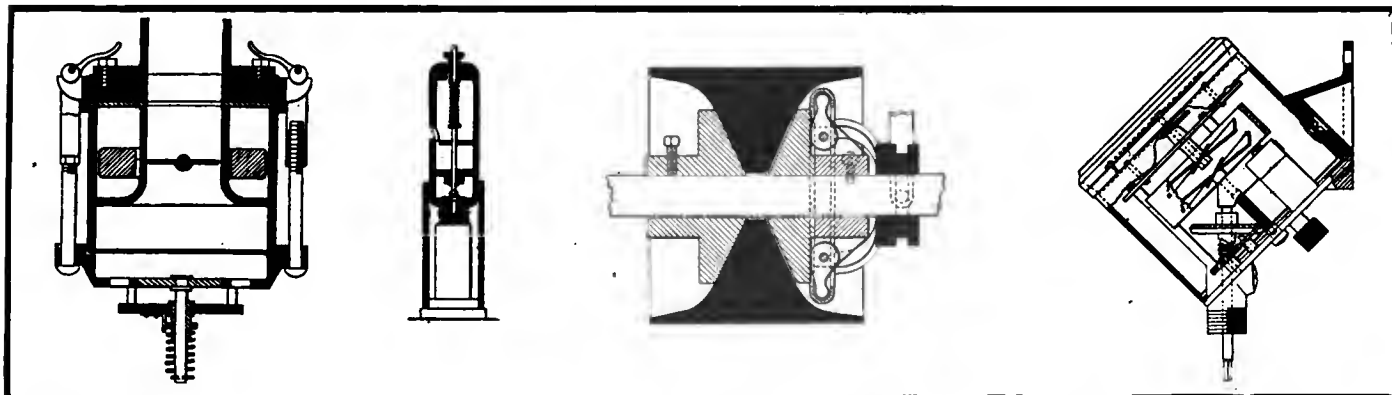

Fig. 1—Zisch carbureter

Fig. 2—Collins' tire signal

Fig. 3—Dennison clutch

Fig. 4—Greenleaf speedometer



# Newest Ideas Among the Accessories

## No-Key Padlock

**F**IGURE 1 is an illustration of the Keyless padlock which may be used for all purposes where this type of lock is advantageously applied. The distinguishing characteristic of this device is that it is locked and unlocked without the use of a key, being complete in itself. The outside of the lock, which is finished in brass, is seen in Fig. 1. This is a front view. There are eight buttons on the front side of the lock and eight on the reverse side, and each of these buttons can be depressed. The buttons, that is, a number of them, for instance, three, are used as a combination which, if properly worked, opens the lock. The combination goes with the lock when this is bought, but no note of it is made on the lock itself. Suppose the combination reads: up, 3 and 6; down, 2. In order to open the lock buttons 3 and 6 are pressed in on the reverse side, and 2 on the front side, all at the same time. This united pressure on the buttons in the combination opens the lock instantly by releasing the male jaw, which is then thrown out of its engagement with the female jaw, while an internal spring throws up the male jaw and opens up a gap between it and the mating jaw.

More than 40,000 combinations are possible, according to the maker, on each lock, so that there is practically no chance of strangers opening the lock. It is of simple and rigid construction and lends itself for manifold uses, in locking the levers to the

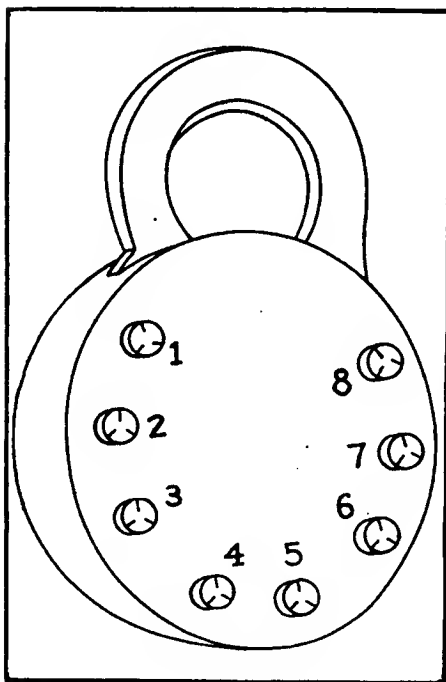

Fig. 1—Keyless padlock

steering wheel or holding the gear-shift lever in neutral through the combined use of a chain and this lock. The one feature of the lock requiring no key is attractive enough, since with the use of this padlock there is no possibility of losing a key, and as a result being at a loss with regard to the locking or unlocking of the lock the key belongs to. The lock is made by the American Keyless Lock Co., 417 South Dearborn street, Chicago, Ill.

## D. K. W. Carbureter

The D. K. W. carbureter, which is shown in Fig. 2, is automatic in a way, in that the ratio between gasoline and air is fixed after the carbureter has once been adjusted for

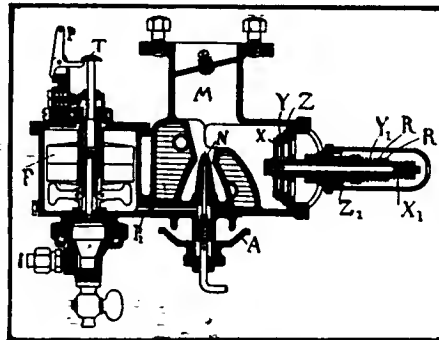

Fig. 2—D. K. W. carbureter

the needs of the engine. The automatic effect is obtained by three auxiliary valves.

The gasoline on its way from the tank enters the carbureter through the inlet I, flowing up through the float chamber and passageway P1 to the nozzle N, and thence through the mixing chamber M to the intake valve of the motor. In installing the carbureter on the car, the adjustable air cup A is first placed in mid-position; then the valve stem is screwed up to close the nozzle tightly, and thereafter opened about one turn, which brings about an approximately correct aperture. The exact opening is determined by experimenting. To prime the carbureter, rod P is so moved as to lift the float valve stem at its top T, permitting the gasoline to flow into the chamber. If the motor, when running at low speeds, shows a tendency to back-fire, stem S is turned outward to enrich the mixture.

The operation of the triple auxiliary air valve is as follows: When the motor draws more air than can pass through the annular opening on top of the cup A, the first auxiliary valve X is sucked toward the motor and lifted off its seat. This permits an additional quantity of air to flow to the engine, but if the suction still increased, the additional lift of valve X compresses

its spring X1 to such a degree that part of its compression is transmitted through spring retainer R1 to R and thence to spring Y1, causing the second valve Y to open and admit more air. If the suction is further increased, the last valve Z is opened and the maximum amount of air obtained. The Duquesne Auto Accessory Co., of New Kensington, Pa., makes this carbureter.

## Schubert Tire Gauge

The Schubert tire pressure tester, Fig. 3, is made in the shape and size of a watch, and may be carried in the vest pocket. The case is made of highly polished nickel, the front side being as illustrated, and the reverse plain metal. The tester is operated by simply pressing the part A on the tire valve, whereby air is admitted from the tire to flow into the gauge, where it moves the finger on the dial to the position indicating the air pressure in the tire. The air or gas is retained in the gauge, which it enters through a non-return valve, and is released by pressure exerted upon the release button R. This construction of the gauge makes it possible for the motorist to make a quick test of the tire pressure without getting down on his knees, and take the reading off the gauge in a comfortable position. The correct pressures for various sizes of tires, as given by the tire manufacturers, are marked on the gauge, which is made by the United States Gauge Co., 67 Wall street, New York City.

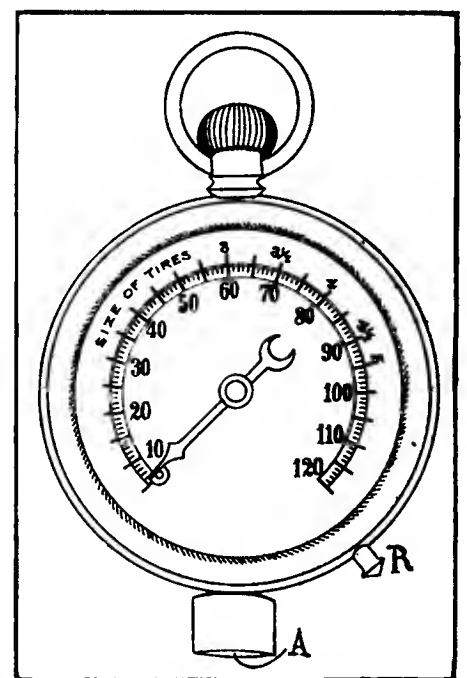

Fig. 3—Schubert tire gauge

# THE AUTOMOBILE

## Across the Continent and Back



Volcanic ash road through the sage brush

**A**UTOMOBILE touring from coast to coast and back again will undoubtedly prove to be an important feature of motor car use. Trips from the Atlantic to the Pacific have been accomplished so frequently and with such a wide variety of cars that the general ability of all standard automobiles to negotiate the physical journey may be said to be firmly established.

The round trip is simply an extension of the one-way journey and is well within the strength and power of any good automobile.

The recent trip of Thomas W. Wilby, special agent of the Office of Public Roads, made under the auspices of the Touring

The Devil's Canyon in Southern California, to descend which was like going down Jacob's ladder

Club of America from New York to San Francisco, Los Angeles and return, something like 11,000 miles, in an Ohio touring car, demonstrated among other things that such a trip does not involve any particular hardship. Mrs. Wilby, wife of the pilot, was a passenger throughout and finished the trip in perfect health. It required 105 days, or an average of about 105 miles for each day.

The car experienced no serious mechanical troubles and Mr. and Mrs. Wilby and driver, F. D. Clark, enjoyed the whole journey. Of course the trip was pioneering in a sense, as Mrs. Wilby is the first woman to accomplish the circuit. Some rough going was experienced; some discomfort was felt at the hotel accommodations in certain spots and there was more or less careful scheduling required in order to insure a plentiful supply of usable gasoline and oil. But these things were all exceptional, the general rule being simply to travel to the scheduled noon and night stops without making any special preparations and arrangements.

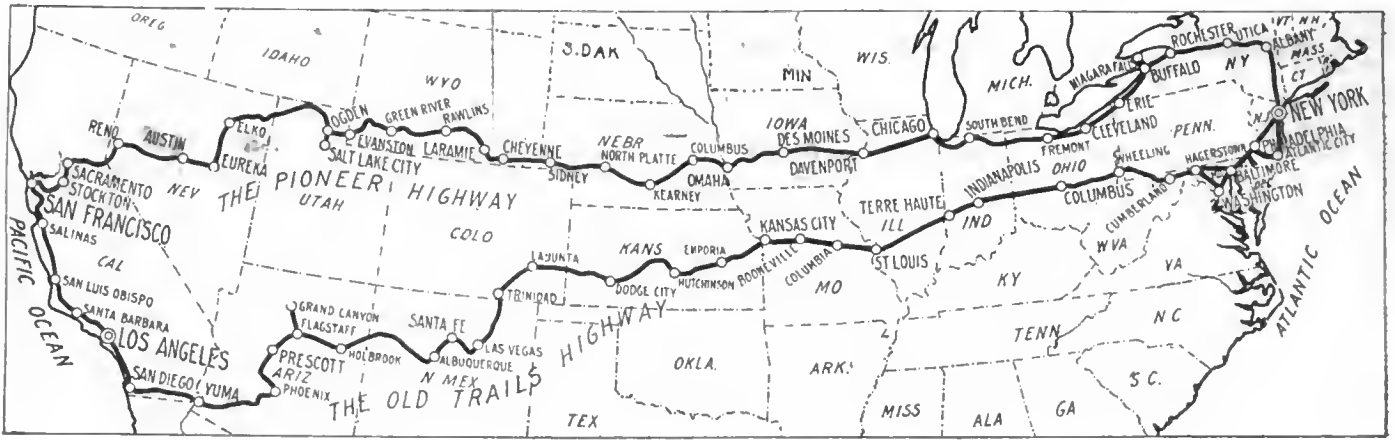

Map showing the route followed by the T. C. A. party in its double transcontinental trip

The average weekly expense for car and driver was \$55 or 7 1-2 cents per wagon mile, which is considerably less than the average operative cost of automobiles.

The route traversed twenty states and touched the republic of Mexico at two points. Mr. Wilby made a special effort to include the show places of the continent in his itinerary and the route he logged will prove popular for tourists of the future who wish to take such a long trip.

The route may properly be divided into seven sections, as follows: First, from New York to Chicago; second, Chicago to Cheyenne; third, Cheyenne to San Francisco; fourth, San Francisco to Los Angeles; fifth, Los Angeles to La Junta; sixth, La Junta to St. Louis and seventh, St. Louis to New York.

Eventually such a tour can be made in 7 weeks, one for each section. At present there are two sections that require less than a week each to cover and at the present rate of road improvement two others will be passable in that period of time within a year. Another will probably be added within 2 years but the last two stretches, the big runs from Cheyenne to San Francisco and from Los Angeles to La Junta, will require longer to reach such a state of perfection.

Mr. Wilby's party was in no hurry. From one end of the route to the other a leisurely pace was maintained. The car was powerful enough to take advantage of good roads when they were met and so it did not have to be forced in the heavy spots. There was more or less social activity all along the route which required extra expenditure of time and the whole trip undoubtedly could have been made in 70 days if there had been any reason for so doing.



Giant cactus found plentifully in Arizona

However, speed on a transcontinental tour by automobile is out of place. The man who merely wants to get from New York to San Francisco in the least number of minutes possible will patronize railroads for many a year. It would

please such a passenger if it were possible to make the journey in one night, or better yet, 1 hour. Scenery, enjoyment and pleasure have no part in such a journey and in an automobile tour from coast to coast and return, there should be nothing but enjoyment.

No matter how perfect the roads of the future may be, the round trip of the American continent should not include speed as its principal factor. The man who could boast of hitting 50 miles an hour in passing the Grand Canon of Colorado has no place in touring literature.

Taking the tour by stages as plotted by Mr. Wilby the conditions to be met are as follows:

The first section, extending from New York to Chicago, needs little notice. It can be done with ease in 5 running days, but should occupy at least 6 days. Starting from New York on a Monday morning in summer, the first day's run to Albany presents nothing but a pleasurable outlook. The roads are boulevarded all the way and first-class hotel accommodations for noon and night stops will be found.

From Albany to Buffalo, the route for the second day may be taken over roads that are almost as good as the foregoing. In Buffalo the hotels are first class.

The third day's run may be to Cleveland, skirting the south shore of Lake Erie. No difficulties will be found so far. There is some poor road included in the fourth day's run and it will probably be found to be advantageous to stop at Toledo for the night. From Toledo to South Bend, Ind., the road is fair to good, with a little poor going. From South Bend to Chicago is generally good.

No difficulties of any kind should be presented by this tour. Gasoline and oil of various kinds may be had every 20 miles if needed and from any point in the road a big city can be reached in an hour's traveling, where suitable accommodations can be had readily.

The second stage, from Chicago to Cheyenne, presents a wide variation from the first section, but imposes no hard obstacles. The first day's run may be to Davenport, Ia., on the Mississippi river. The Illinois roads are good in dry weather and passable in wet and there are numerous big cities between Chicago and Davenport that will afford everything necessary for the comfort of the tourists.

After crossing the Mississippi the way leads over the famous River to River road. This is a fine highway in dry weather, but all but impossible after a rain. The true significance of gumbo can be learned on the River to River road if there has been a wet spell just before starting from Davenport. Assuming that the sky is clear and there has been no heavy rain for a week, the trip to Des Moines, capital of Iowa, will be a pleasure.

Precisely the same conditions obtain for the run from Des Moines to Omaha that exist from Davenport to Des Moines. The road is better than Fifth avenue in dry weather and worse than the road from Natural Bridge to Roanoke, Va., after rain.

The Missouri River is crossed at Omaha and before the tourist stretches away the great plains where once roamed the buffalo, but which have now been converted into the granary of the nation. Up to a very recent date the roads through Nebraska have been unimproved and touring over them has been anything but a pleasure. There is little macadamizing to be found even now, but fully half of the distance from Omaha to North Platte has been graded and dragged. If the weather has been dry, or if the roads have had a chance to dry out for 24 hours before starting over them, there will be no particular trouble to be found. From this point west mileages, however, will have to be cut down sharply.

It will be well to try to go no further than Columbus on the first day out from Omaha. The roads are not bad, particularly in dry weather, although after a protracted drought there will be much dust. The next day's trip should be to Kearney and the next to North Platte. The character of the country has changed radically from what was found further east. The tourist is on the edge of the dry country. From Kearney west the dry, rolling hills are covered with sage brush where they have not fallen under the hand of the agriculturalist.

Only 30 years ago this whole country west of the Missouri river was deemed to be fit for a cattle range only. Gradually the desert limits have been pushed back and to-day heavy crops of grain are raised without irrigation clear to the Wyoming line. But here and there the tourist may still see a vast sweep of sage covered hills, extending to the horizon. The air is dry and clear, and touring, if done without too much effort at speed, will be found to be delightful.

But upon leaving North Platte it will be just as well to arrange for supplies of gasoline and oil at various intervals beyond Cheyenne. At Laramie, Rawlins, Green River and Evanston such supplies can be had, but if it is not possible to order fuel and oil to be delivered along the route at convenient intervals provision for an emergency supply to be carried in the car itself should be made. It is not a pleasant thing to think about running short of fuel, water or oil on a lonely desert or mountain trail, far from human habitation. It is much better to carry an extra supply, even though arrangements can be made to get supplies along the way.

Sidney is a town of comfortable size and should be the first night stop beyond North Platte. The run from there to Cheyenne is rather long, but the road is well marked and presents no particular difficulties.

Cheyenne is pretty well up in the Rocky Mountains and from there to the Utah state line the tourist would better make haste slowly. While the distances between considerable towns is not great, it is quite certain that the breaking of an axle 20 miles from one of them would prove serious enough. The answer is to drive slowly and carefully, avoiding irrigation ditches and using much judgment in crossing what are known as dry washes and high centers. The first step across Wyoming is from Chey-

enne to Laramie. This is a stiff climb to the level of the high plateau, across which the Union Pacific tracks traverse the backbone of the continent. The road surface is not bad practically all the way to Laramie and the tourists will pass the Sherman monument, marking the highest point on the continental divide, before reaching Laramie. This is 8,010 feet above sea level. Medicine Bow, a small place with a good hotel and where necessary supplies of fuel and oil may be obtained is far enough away from

Laramie to make a good mid-day stop and from there to Rawlins, 57 miles, the road traverses a wild country where ranch houses are few and precautions as to fuel should be taken. The route is some distance from the railroad.

At Rawlins all necessities and many comforts are available. The main hotel is comfortable and there are several garages and supply depots.

There is a good road out of Rawlins as far as Wamsutter, where the trail enters the Bitter Creek country. Desolate solitude about describes the aspect of nature through this stretch of the way and it is not much improved in crossing the Red Desert, which has been described as the worst link in the continental chain of highways. This road however, is not superlatively bad. It is much more easily traveled than would be the River to River road in Iowa after a hard rain. It is rough and difficult, but in any long tour worse roads will be found in spots. Rock Springs, a small railroad town, affords about the only chance for a night stop in this territory. The accommodations are not what may be termed luxurious.

From Rock Springs to Green River the road is excellent and noon stop may be made at Green River. Granger lies a short distance beyond. This place is known as the gateway, from a railroad viewpoint, to the whole intermountain region. West from Granger the old road, used by former tourists, may be



Beautiful natural road through Dog Valley



A typical panorama encountered by the Wilbys in their journey through the Great Southwest



Lava-strewn mountains in Arizona through which the travelers progressed at a snail's pace

abandoned and striking off to the south a better road will be found that is fully 30 miles shorter to Evanston. This passes through Lyman and Bridger, prosperous farming communities, where smart efforts at road improvement have been made. The road out of Bridger is not well posted and much care should be exercised to get on the right road. Within the past few weeks this section has been posted so that mistakes in future need not be numerous. The last 20 miles into Evanston is over excellent road.

Gasoline is scarce in this country but may be had. Provisions for oil are necessary. Evanston has everything necessary in the way of supplies and accommodations, but not many luxuries.

The next day's run is short, only 86 miles to Ogden, Utah, but it is one of the most delightful trips possible to modern motoring. The way leads through a series of small fertile valleys, well watered and productive under the hands of the Mormons. The road is fine and the scenery, particularly after reaching Weber canyon and Devil's Slide, is gorgeous in the extreme.

Ogden affords practically everything the tourist could find in an eastern city, including excellent hotels. If desired, the tourist may run down to Salt Lake City and, after spending as much time as he wishes in sightseeing, can run back to Ogden to resume his westward way.

This may be a day or a week, for the Mormon capital is a fertile field for the tenderfoot tourist. Park City and its silver mines and the various wonders of the region may be inspected with pleasure and profit. Salt Lake is only 35 miles south from Ogden and the roads are fine, but rather dusty.

West from Ogden the road lies through an absolute desert. There are hundreds of miles of alkali flats that are as forbidding and austere as a New England old maid. After rounding the Great Salt Lake to Lucin, the trail strikes southwestwardly to Montello and Elko, Nevada. The roads are good all through

this section and passing south through the Diamond Valley to Eureka. There is much wonderful scenery in this valley, the desert scheme of coloration appealing with much strength to eastern visitors. Turning west at Eureka the road strikes across the desert toward Reno, passing Austin and Fallon. The tourist should arrange a sliding schedule across the desert west of Ogden. Extra supplies of water should be carried in the car and a fuel and oil schedule ought to be made in advance. The towns are infrequent, but a night schedule can be arranged that will not necessitate any camping out. Eureka is 106 miles from Elko, mostly over good gravel roads. The little city has a good hotel and offers an opportunity to get fuel and oil. Eastgate should be the next night stop, 130 miles west of Eureka. A ranch house is about the best that it can offer in the way of hotel accommodations and care should be taken to secure a supply of fuel. The run into Reno is through much the same kind of territory. At Reno there will be no trouble about accommodations and supplies.

The climbing of the Sierra Nevadas to Truckee presents quite a problem for any kind of transportation. The roads are not bad, but the grades are terrific and entirely impassable after a snowstorm. Such storms, however, are not frequent except for about 6 weeks in the dead of winter, when no sane human being would want to go mountain climbing. From Truckee to Sacramento the way is sharply down-grade, winding in and out among the mountain peaks of the great coast range. On the down turn the road passes through the section where gold was first discovered in California and leads by easy stages to San Francisco via Stockton and Oakland.

An extra week ought to be put in by the tourist in examining Nevada with its marvelous mines and wonderful color plans, but a week more can be spent enjoyably in the Sierras and 2 weeks is not too long to enjoy San Francisco after the long trip.



Through the cotton fields of Southern California, where the roads were generally excellent





Montezuma's Castle is a huge cliff dwelling in the limestone bluffs north of Prescott, Arizona.

The fourth stage of the great round trip extends to Los Angeles. The Californians declare that the route is perfect, but the eastern tourist will find that it is not. Except for considerable macadamizing near San Francisco and Los Angeles the road is rough and dusty except during the rainy season and deep and muddy during the rainy season.

Los Angeles is one of the garden spots of the world and is deserving of an extended visit. It has the largest number of automobiles per capita of any large city in the world and its roads are wonderfully perfect, particularly in the territory immediately adjacent to the city.

On the eastward way the tourist must take his own time. There is something interesting in almost every mile and haste will serve to spoil many a memory that otherwise would prove a pleasant possession. And there is another excellent reason for moving deliberately, for the roads are very rough and heavy in long stretches.

It is just a nice easy run from Los Angeles to San Diego and the roads are good all the way. Then the course turns east and passes Campo, the Devil's canon, Imperial and El Centro. The roads are very narrow and winding and the scenery is sublime. After El Centro the way leads out upon the floor of the desert. Following this there is a space of 60 miles of exceedingly rough going, the trail crossing the international line into Mexico and returning at Aldrado. From there to Yuma, Ariz., the road is a severe trial. After leaving Yuma the first big obstacle to be passed is the ford of the Gila river. For a considerable period of each year this stream is too shallow to ferry and too deep to ford. Provision for a team of mules to pull one's car through this stream should be made. From the east bank of the river into Buckeye the road is indescribably rough and 10 miles an hour is a perilous rate of speed. But from there to Phoenix the roads are fair to good. A side trip to the Grand Canon should

be made from Flagstaff before taking up the tour again. The roads from Phoenix to Prescott are fair to excellent and from Prescott to Flagstaff poor to fair.

Arizona presents a virgin field for the tourist. There is something wonderful to be seen every hour in the day, the enchanted, petrified forests and real forests; the fields of green grain and the spectacular cactus, combined with the sweep of the desert and the grim strength and ruggedness of the mountains.

The route passes through Holbrook and continues to the New Mexican line without radical change in topographical characteristics. Albuquerque, the ancient capital, is the first New Mexican city of size to be encountered. Then come Santa Fe and Las Vegas in the Raton Mountains. The Raton (pronounced Ratoon) Pass, across the summit of the Rocky Mountains, is the last bit of major mountain-climbing on the route. The country is practically flat at Trinidad, Colo., and thence out on the dry plains to La Junta (pronounced La Hoonta), where the fifth stage of the journey ends.

From La Junta to St. Louis is a very easy run compared with what has gone before. There are no hills to climb of any great size and the Kansas roads are fair to good generally. If it is wet, however, the going will not be enjoyed and if it is very dry there will be much dust. In Missouri the roads are deep in spots and rough in others, but much road improvement is being made in that state.

The chief cities touched by the return route are: Dodge City, Hutchinson (the salt center), Emporia, Kansas City, Booneville, Columbia and St. Louis. East from St. Louis the way leads through Illinois to Terre Haute, Ind., Indianapolis, Columbus, O., Wheeling, West Va., Cumberland, Md., Hagerstown, Washington, Baltimore, Philadelphia, New York.

The direct route, without side trips of any kind, measures about 8,500 miles. The side trips have a mileage of 1,500. Mr.



Donner Lake, California, a beautiful spot where many tragedies were enacted in the pioneer days



Arrival of the Wilbys in the Ohio Mudhen with their escort at the headquarters of the Touring Club of America

Wilby's party covered 1,000 miles more than this, but it is a matter of individual taste as to whether this additional mileage should be included.

The late summer is an ideal time to start such a tour and the northerly route followed on the way west will do much to temper summer heat. Then, by the time the party has reached Los Angeles, the season will be so far advanced that the southern route returning will prove more agreeable than the one through the northern mountain passes.

Mr. Wilby states that no special equipment is necessary for this long tour, but in his notes he calls attention to the fact that the car was furnished with a heavy tarpaulin or oil-cloth cover for use in heavy rain or hail.

There is no necessity of carrying a camping outfit unless the taste of the party is in that direction, for some sort of accommodations can be found at each night stop. Once in Nevada and twice in the southern desert the party had to sleep in ranch houses and the hotels could not be termed luxurious outside of California west of the Missouri river. Here and there is to be found an excellent hostelry in the intermountain region, but the general run is not like the eastern or California hotel.

Good, warm clothing and complete waterproofs are essential to health and comfort on such a trip, but care should be taken not to clutter up the car with a lot of unnecessary baggage. Every extra pound counts on a short tour and on one including 10,000 miles one extra suit case weighing 50 pounds may mean the difference between comfort and misery from one end of the ride to the other. Only such baggage should be carried as may be packed securely in a canvas cover and strapped behind the car. A hand bag in the tonneau is an abomination. It either crowds the back seat or hampers the foot room. On a short trip such an inconvenience is trifling, but on one that is long it is about as trying as could be.

Another bad effect of extra and unnecessary baggage is its destructive tendency as far as tires are concerned. At normal load and inflation tires are made to deliver a minimum mileage by their manufacturers. If 50 pounds is carried over the normal load the tires are surely going to suffer.

Arrangement can be made before starting to have laundry work done at various points en route. If an emergency camping outfit is carried it should contain absolutely nothing that can be left behind. A portable alcohol lamp, a silk dog-tent and a single pot and pan. The robes of the car can be used as bedding in a pinch. Emergency rations, ready packed, will furnish enough food to keep soul and body together until some haven of refuge can be reached. The whole outfit should not weigh over 25 pounds.

Gasoline can be had all along the route at convenient intervals, but in some sections it is much scarcer than in others. In price it ranges from 11 1-2 cents to 50 cents a gallon. The latter price obtains where there is the least supply. On this trip the point where gasoline is highest is between the large towns of Arizona and to a degree in Wyoming and Nevada. At Omaha the tourists will do well to buy three cans for emergency use. One should carry gasoline, another oil and the third water. They may not be used at all, but in case of need they will prove to be wonderfully welcome. It is possible to strap these cans on the running boards and in the tonneau, so that they will not crowd the passengers.

Within the next year or two many automobile parties will make this trip, and as each successive car passes over the route it will be found that road conditions will show improvement. The whole country is alive to the need of good roads and the mere plotting of such a double transcontinental tour will undoubtedly lead to considerable immediate interest in this route. It should be understood that the mountain passes in Wyoming and at Truckee are impassable for automobiles in winter and that the Yuma desert, Arizona and New Mexico are not pleasant touring grounds in July and August. And, on the other hand, the trip across the plains is not pleasant in wet weather and early spring touring is not pure joy in the east. Therefore such a trip as Mr. Wilby made should be undertaken systematically and with due care to avoid the unpleasant features noted above. May would be a fine time to start, but August would be better, particularly if the tour is to be leisurely, as it should be to properly enjoy the beauty of the scenery along the route.

### Maryland Motorists Must Go for Tags

BALTIMORE, Md., Dec. 18—Judge Gorter, in an opinion which he handed down in the Superior Court, held that the State Motor Vehicle Law does not require the Commissioner of Motor Vehicles to deliver license tags to the homes of owners of cars. The question raised was whether the law required the Commissioner of Motor Vehicles to deliver the metal plates or markers which the law required to be attached to motor cars to the owners' homes, the complainant in the case being William B. Littleton, of Hagerstown, Md.

### Road Experts Meet in New Hampshire

CONCORD, N. H., Dec. 18—The first good roads convention ever held in New Hampshire—and the second ever held in New England, the first being at Boston three years ago—ended its deliberations to-day after being in session two days, during which time about 300 men prominent in highway maintenance work had a chance to exchange ideas on the subject.

Governor Robert P. Bass was instrumental in bringing the convention here and he had Federal and New England officials as guests to give an outline of what New Hampshire needed.

## Industrial News by Mail and Wire

**D**AYTON, O., Dec. 18—The first annual Speedwell truck convention, just held at the factory, was a success from every standpoint. The agents received much valuable information from Mr. R. Harry Croniger, who has charge of the truck end of the Speedwell business. The burden of his instructions was: First, in showing truck prospects how methods of handling goods may be re-adjusted, and second, demonstrating the economy of the truck and then giving a conservative and liberal estimate of the probable operating costs and if trucks are installed to co-operate in educating drivers and mechanics to give the trucks the sort of attention and consideration which will produce greatest efficiency.

Those of the agency force present were: B. A. Jackson, New Orleans; Frank A. Groves, Chicago; H. D. Hudson, Minneapolis; P. D. Karshner, Kansas City; L. V. Lynch, San Francisco; George L. Baker, Dayton; Paul C. Curtis, Boston; G. B. Garrison, Chicago; A. J. Sanderson, Buffalo; C. A. Nation, Portland, Ore.; John Cunningham, Rochester; W. L. Hicks, Nashville; N. J. Adams, Troy, N. Y.; Eugene Hanking, Jacksonville, Fla.; E. A. Shanks, Louisville; George Turner, Pensacola, Fla.; J. B. Hastings, Montgomery, Ala.; W. P. Peterman, Franklin, La.; J. A. Kays, Meridian, Miss.; Mitchell Nash, Waco, Tex.; Will Spring, Houston, Tex.; Walter C. Martin, New York; H. H. Hawkins, Los Angeles; E. B. Jenkins, Pittsburgh, and Lloyd Richards, Mobile, Ala.

### To Double Output of Grinnell Electrics

DETROIT, Dec. 16—At a meeting of the Grinnell Electric Automobile Co. to-day the directors decided to double the output for the coming year, enter the wholesale field and begin an extensive advertising campaign. Henry Goodman, of New York, was present, and a contract was closed with him to represent the company in the East.

About three weeks ago the company, which formerly was the Phipps-Grinnell Electric Auto Co., was reorganized, C. A. Grinnell and I. W. Grinnell, of the firm of Grinnell Brothers, the largest piano house in Michigan, purchasing the stock of Joel G. Phipps, giving them a majority of the holdings.

### New Company to Handle Imported Cars

Three veterans of the automobile business have formed a new company, with headquarters in New York, to handle several makes of imported cars. These are Paul Lacroix, Harry U. Kibbe and Stefan G. Kjeldsen, and they are organized under the firm name of the Paul Lacroix Automobile Co.

The new company has the exclusive agency in this country for the English Daimler, Clement-Bayard, Itala and Zedel, and will also sell Renault and Panhard cars. The Zedel, which is new to America, is a small car. The new company will exhibit at the Importers' Automobile Salon, showing its different makes with bodies by Demarest.

### Ford Co. Cuts Giant Melon

DETROIT, MICH., Dec. 18—While the motor car concerns are not disposed to tip off their plans in advance, it is said that several of them have arranged to remember their employees in one way or another, while there are rumors of a number of large-sized dividend distributions. The Ford Motor Co., it is learned on good authority, recently distributed \$1,000,000 among its stockholders, Henry Ford receiving a little less than 60 per

cent., and no doubt some handsome bonuses will be forthcoming if the sales department makes good on its estimate of 75,000 cars for the 1912 season.

### Motorette May Be Reorganized

HARTFORD, CONN., Dec. 18—Although no official announcement to the effect has been made, it is understood on excellent authority that an effort will be made to reorganize the C. W. Kelsey Manufacturing Company, of this city, manufacturers of the Motorette and that the new company will continue to make the three-wheel motorcars.

The Motorette Company was formed last fall to manufacture a three-wheeler at Hartford, C. W. Kelsey, formerly of the Maxwell-Briscoe Company, being at its head. It was backed with Philadelphia capital. It has been in difficulties several times during the past year and its present trouble is the cumulative result of a number of similar crises. Formal action was commenced at Hartford on December 6.

### Universal Truck Co. Reported Sold

DETROIT, MICH., Dec. 19—The Universal Motor Truck Co. has been sold to Howard W. Walton, of New York, according to announcement this afternoon. The corporation is capitalized at \$350,000. Among those who are reported to have sold their holdings to Mr. Walton are the following: C. H. Haberkorn, C. B. Culbertson, August Kling, A. E. Barker, George Uhlein and Louis Camper.

### U. S. Motors Netted \$2,040,256

Stockholders of the United States Motor Co. held their annual meeting Tuesday and elected J. W. Stoddard to succeed H. J. Edwards on the board of directors. The annual report of the company showed a net profit up to the end of the fiscal year of \$2,040,256 and after dividends, interest and depreciation had been deducted it left a net surplus of \$453,748.

There has been a marked advance in United States Motor stock on the Detroit exchange the past few days. Common has jumped from 13 to 20 and preferred from 55 to 62, with the upward tendency apparently unchecked.

### Lozier to Put Out Big Truck

DETROIT, MICH., Dec. 18—It is reported that the Lozier Motor Co. is preparing to put a high-power truck on the market in the near future, and may have it ready for exhibition at the Detroit show along with several other cars. The company's engineering department has given the truck question a good deal of careful study and several new ideas will be incorporated in the forthcoming truck, it is understood.

### Hupp Announces New Touring Car

DETROIT, MICH., Dec. 18—R. C. Hupp has announced four self-starter models of the new R-C-H car, including a five-passenger touring car, a two-passenger roadster, a touring roadster and a Colonial coupé. All are equipped with dual ignition, demountable and quick detachable rims, 32 x 3 1-2 inch tires, Prestolite tank, extra rim, top, side curtains and all the rest. Mr. Hupp plans to display his full line at the Detroit show.

## The Legal Field—Spark Plug Suits

**S**PARK PLUGS next will be the focus of interest in the automobile world. The whole matter of their legal status is about to be threshed out before the United States court in New York when the legality of the Mosler patent is put to the affirmative test, probably at the February term.

A. R. Mosler & Company have commenced actions against the Auto Supply Company, John Lurie, president, involving alleged infringement of the patent owned by the Mosler company on the part of the Metzger, Rogers, Belgian, Rajah and American Coil Company spark plugs. Suit has also been brought against the Emil Grossman Company, the Champion Spark Plug Company and the Jeffrey & DeWitt Company in the Federal courts at and near Detroit and a similar action has been entered against the Motor Car Equipment Company.

The suits are all similar and the complaint alleges infringement of the Canfield patent No. 612,701, now owned by the Mosler company, covering the two claims following: "In a gas, oil or vapor engine igniter or sparker a recess or counterbore around the electrode or electrodes, above the sparking point or points when said electrodes are used vertically, for the purpose of preventing an injurious accumulation of the products of combustion or other foul matter on the insulation of said electrodes."

The second claim is for a recess or counterbore of such depth and size as to form space for an air cushion and prevent the circulation of the explosive mixture into such counterbore.

The *prima facie* proof has been made and practically all the testimony in the most advanced cases has been taken before the commissioner, and Judge William A. Redding for the Mosler company, believes the cases will be ready for adjudication before the end of the year. Under fair circumstances a final decree of the court of last resort can be had within the next year.

The history of the patent has a tinge of romance connected with it. It was issued to Frank W. Canfield, of Manistee, Mich. (now dead), October 18, 1898, and consequently has nearly 4 years to run. On the recommendation of Mr. Redding it was purchased for a substantial sum by the patent association affiliated with the A. L. A. M. During several years it lay dormant in the treasury of the association while the attention of the automobile world was centered on the Selden litigation. But about 2 1-2 years ago, Mr. Redding advised the Mosler company to purchase the patent and that action was taken. Under the terms of purchase the right was given to each member of the A. L. A. M. at that time to manufacture plugs under this patent for its own product, without royalty. The Mosler company issued a license or two to other manufacturers and the present suits are the result of its efforts to assert its exclusive rights to the device covered by the Canfield patent. The complaint asks for injunction, accounting and damages, amounting in the aggregate to about \$1,000,000. The deposition of Prof. Carpenter, of Cornell University will be taken in support of the Mosler claim.

### New Patent Laws May Affect Industry

WASHINGTON, D. C., Dec. 16—Never before in the history of patent legislation have bills and proposed legislation been introduced in Congress of more vital importance than during the present session. The newly introduced bills, numbering nineteen in all, cover patent matters of deep interest to the motor car industry. One of the patent bills now pending proposes compulsory license. Under its terms the owner of a patent is put in a peculiar situation. If another inventor wishes to use it for an improvement on an invention he has only to apply to the Commissioner of Patents and get a right to use the patent upon

terms without any notice or hearing. Another drastic bill provides that a patent granted upon an improvement on a machine, etc., previously patented shall expire at the same time as the original patent. The other bills are equally drastic.

It is known that influences are at work in Congress to secure, if possible, a radical change in the patent laws, and the introduction of these bills is the first step in that direction. According to noted patent attorneys these bills, if passed, will effect such a complete revolution in the American patent laws that various industries will be stunned by the differences in their legal rights under the existing and under the proposed laws.

### Klaxon Fails to Restrain Newton

United States Judge Thomas I. Chatfield has denied the motion of the Lovell-McConnell Mfg. Company, makers of the Klaxon horn, for a preliminary injunction against the Automobile Supply Mfg. Company, makers of the Newton horn, and has decreed that all questions of alleged infringement and other defenses shall be reserved for final hearing. The court also prohibits both litigants from making or circulating statements likely to hamper the court in coming to a prompt decision.

The Newton party is specifically prohibited from circulating the literature known as *The Truth and The Facts in the Case*, and the complainants are barred from bringing actions apparently based only on the hope of intimidating customers of the defendants.

The case will probably be heard in April, 1912.

The decision is as follows:

"This cause coming on to be heard on Sept. 25, 26 and 27, upon complainant's motion for preliminary injunction under the patents number 923,048, 923,049, 923,122, granted to Miller, Reese, Hutchison, on May 25, 1909: On complainants' motion to enjoin the publication by defendants of a certain circular entitled (*The Truth*), or (*The Facts in The Case*); and further on defendant's motion to prevent further prosecution of a number of pending actions and the bringing of any additional actions against defendant's dealers and any intimidation of defendant customers and the trade generally; and on reading and considering on behalf of the complainants twenty-four affidavits, with exhibits therein identified, and after hearing George C. Dean, and T. J. Johnston, of counsel for complainants and C. A. L. Massie, and Ralph L. Scott, of counsel for the defendants, both orally and by briefs, and the court being fully advised in the premises, and having under date of Nov. 20, 1911, handed down a written opinion—now, on motion of C. A. L. Massie, solicitor and of counsel for defendants, it is this day ordered that complainant's motion for preliminary injunction under the three patents aforesaid, be and the same is hereby denied and all questions as to alleged infringement and other defenses are reserved for final hearing.

"And it is further ordered, that in order to prevent a recurrence similar to those relating to the matters of advertising and threatened suits, the complainants and the defendants be and they hereby are enjoined from any act or proceeding which will embarrass or prevent this court in bringing this suit to a prompt and complete determination upon the merits. That any suit brought by complainants under the patents aforesaid, based upon the existence or use or sale of defendant's said Newton horns, and in which the issue shall be dependent upon the same conclusion as the issues herein, shall not be carried beyond the point of serving process. And that this injunction includes such institution or prosecution or litigation in other districts as will ap-

parently be for the purpose of intimidation or punitive effect alone. And it is further ordered that the defendants and their agents and attorneys be and they hereby are enjoined from circulating, in the same or similar form, the contents of the circular known as (The Truth) or (The Facts in The Case), set forth in complainant's papers, and both parties, their agents and attorneys are enjoined from attempting to present to the public and to their customers their views as to the meaning and effect of the evidence already presented, or as to what it may have shown in the present action (but counsel may explain the same to persons entitled to the information), in order that, whichever party shall ultimately prevail, the trial of this action will not be affected thereby in matters to which the decree of the court cannot effectively reach.

"And that in view of the previous disputes arising herein, the defendants be and hereby are enjoined from making to the public or the trade or to any jobber, dealer, or purchaser of warning signals, either verbally or in writing, in the same or similar form, any statement such as made in the exhibit letter regarding preliminary injunction, the patents in suit, the question of infringement or complainant's course with regard to the same. And that the complainants be and are hereby enjoined from making or circulating any of the statements heretofore restrained by this court.

(Signed) THOMAS I. CHATFIELD,  
United States Judge."

### A.L.A.M. Patents to Undergo Court Test

Proceedings in the suit against the Palmer & Singer Mfg. Co. were brought to public notice during the past week by the sending of more notices on behalf of the plaintiff in the case, warning of alleged infringement of the Dyer patents.

The suit is in the United States District Court, Southern District of New York, and has been pending for some time. The Dyer patents include one covering an H-slot guide plate for the controlling lever; a gearing for automobiles; a slide gear; unit power plant and a planetary gear device.

The A. L. A. M. was interested in the patents and was empowered under its rights to give shop licenses to any of its members. The Palmer & Singer Co., while a licensee of the A. L. A. M., never applied for such shop license, according to officials of that organization.

Dyer is proceeding to stop the alleged infringement of his patents and to collect damages for such infringement. The case may be reached during the coming term of court.

### Electric Storage Battery Company Wins

Denying a motion for a rehearing, the United States Circuit Court of Appeals has settled finally the preliminary stage of the battle that has been waged for several years by the Gould Storage Battery Company and the Electric Storage Battery Company, in which the former sought to force the latter to convey to it the Madden patent owned by the Electric Storage Battery Company. The court below decided against the Gould company and the upper court sustained the decision.

The present status of the litigation is that the Gould company is suing the Electric company in the New Jersey federal court and the Electric company is suing the Gould company in the western district of New York. Both suits allege infringements.

The Madden patents are two in number. The first of these, 570,244, was granted October 27, 1896, covering a machine for transforming, reducing and preparing lead blanks for storage battery requirements and to produce grids of various sizes and kinds. The second patent is No. 572,363, for a machine to make grids with shelves or partitions which have uniform molecular density. This patent was issued December 1, 1896. The first is owned by the Electric company and the second by the Gould company.

The court in deciding the matter at issue concludes with the

following paragraph: "This unfortunate controversy could have been avoided had the inventor been less disingenuous and had the parties observed with greater care some of the principles of the Decalogue. Neither party is blameless, but we are unable to say that the proof preponderates so strongly in favor of the complainant as to justify us in granting the extraordinary relief demanded. The decree is affirmed with costs."

### Auto Lighter Sues on Patents

Suits have been filed in the United States Circuit Court by the Auto Lighter & Equipment Co. of Massachusetts against the Inst Lighter Co. of Ohio and the Oldsmobile Co. of Massachusetts for alleged infringement of United States letters patents 953,985 and 962,113.

The Motor Specialties Co. of Boston, manufacturers of the Flash auto lighter and licensee under these patents, also appears as complainant in the above suits.

It is claimed that these patents broadly cover a safe and positive system of automatic acetylene gas ignition, particularly in the fact that the igniting spark precedes the gas at the headlights.

Another feature claimed under these patents is a single operating handle for controlling both the gas and the electric spark to light or extinguish the lights with one movement, which handle locks in on or off positions.

### Weed Chain Gets Six More Injunctions

The past week has been lively for the Weed Chain Co. in the courts. Preliminary injunctions have been granted on behalf of the company against three concerns within the jurisdiction of the United States courts in the eastern division of northern Ohio as follows: The Studebaker Automobile Co., M. and M. Co., and Dorsey D. Foote. This action is similar to numerous others taken by the Weed concern to enforce its patent rights.

In the United States Circuit Court in New York orders were signed to extend the time for taking testimony in the actions of the Weed company against Edmond, Wooster and Newhall. These suits are like the others in general scope.

Word comes from Detroit that on Tuesday last, Judge Angell, on complaint of the Weed company, authorized a preliminary injunction against the Perry Chain Grip Company, the Union Steel Screen Company and The Motor Specialty Company, restraining them from placing the "Weeder" auto chain grip on the market. The action is based on an alleged infringement of the Parsons patent by the manufacturers of the "Weeder" chain. This the defendants admitted, but counsel declared the patent would be proved invalid on facts not presented in the Snyder case. An injunction was also sought to enjoin the Perry grip, but the court declared this would have to be taken up later.

### Victor Creditors to Get Xmas Present

As a kind of Christmas present to the creditors of the Victor Auto Supply Manufacturing Co. an initial dividend amounting to 2 per cent. of the approved claims has been declared by the United States District Court officials in bankruptcy.

The dividend will be payable December 28. The dates of subsequent payments in this estate and their amount will be determined later.

### Zust Debts May Be Compounded

Walter E. Coe has been named receiver for the Zust Sales Co., of New York, the concern handling the product of the Zust factory in this section. An effort is being made to effect a composition of the matter and the prospects for such an outcome are said to be excellent.

The assets and liabilities are unofficially declared to be about \$35,000 each.



# Rules for the French Grand Prix

IN the following translation of the official regulations relating to the Grand Prix and Coupe de l'Auto races to be held in June, 1912, under the auspices of the Automobile Club de France, the French wording has been followed as literally as practicable and without close adherence to the terminology currently adopted in this country, the object being to render faithfully, for the information of all American manufacturers, drivers and general readers, not only the general trend of the regulations but also particularly those provisions which seem to open loopholes for unexpected interpretations or which contain mandatory injunctions of an unusual nature.

## Official Regulations for the Grand Prix of the Automobile Club de France, June, 1912, and for the Coupe de l'Auto

- 1—The Automobile Club de France organizes for 1912 an international race reserved for constructors defined under section 4 and entitled the Grand Prix de l'Automobile Club de France.
- 2—In this trial shall be incorporated the "Coupe de L'Auto" for the vehicles conforming to the formula for the "Course de Voitures Légères, 1911," as given in section 13. These vehicles shall at the same time participate in the general classification.
- 3—A prize of 20,000 francs shall be awarded to the constructor of the vehicle arriving first under the general classification. A prize of 10,000 francs shall be awarded to the constructor who has the team securing the best position with a minimum of three vehicles finishing.
- 4—As constructor is considered one who has manufactured both the motor and the transmission.
- 5—The race will take place during the second half of June and will comprise two consecutive days at the rate of 800 to 1000 kilometers per day. The date and place will be decided later.
- 6—*Entries:* Each constructor has the right to enter 4 vehicles with the option of taking part at once in both trials, it being understood, however, that the total cannot exceed four.
- 7—Constructors employing motors or mechanisms built under the same license, or under a title into which the same name enters, cannot together engage more than four vehicles.
- This rule applies without regard to nationality and whether the license is granted by a foreign constructor or vice versa.
- In case of disagreement among firms manufacturing vehicles under the same license, the Sport Commission will decide the number of vehicles to which each firm shall be entitled, basing its decision on the importance of each firm as evidenced by the number of vehicles it has delivered to the public during the past three years; and, whatever the number of constructors involved, no exception will be made from the second paragraph of this section.
- 8—*Entrance fees are:* Fifteen hundred francs for one vehicle, 2,750 francs for two, 3,750 francs for three, and 4,500 francs for four. The nominations must be submitted at the office of the Sport Commission of the Automobile Club de France at No. 8 Place de la Concorde, and the list will be closed on December 30, 1911, at 6 o'clock evening. The entries will not be definitely accepted unless at that time the number of vehicles nominated reaches a minimum of thirty. If this quorum were reached December 30, entries at double fees could be validly submitted to the Sport Committee until March 1, 1912, at 6 o'clock evening.
- 9—The entrance fees cannot in any case be refunded and will remain as acquired for the race fund, excepting the case provided for in the third clause of the preceding section.
- 10—*Entries will be recognized as valid only if accompanied by the fees as provided in section 8 and contingently upon acceptance by the Sport Committee.*
- 11—If the number of entries should be judged too great, for reasons of safety, the Sport Committee reserves the right to reduce it, by selection, drawing lots, eliminatory trial or any other means at its option.
- 12—*GENERAL CONDITIONS:* The Grand Prix is open to all vehicles without other limitations than those resulting from the provisos of section 18.
- 13—The vehicles taking part in the "Coupe de L'Auto" must satisfy the following conditions:
  - (1) Must be equipped with a motor of at least four cylinders, whose total cylinder volume does not exceed three litres, and in which the ratio of stroke to bore cannot be higher than two or smaller than one. The constructor must thus keep within these limits, no tolerance being allowed.
  - (2) Must weight at least 800 kilograms. This minimum weight is to be understood as follows: The weight of the vehicle with two-seated body, without water, oil, gasoline (essence), tools, spare parts. (Emptying of the crankcase and gear cases will not be required.)
- 14—The Sport Committee reserves the right, at the beginning of the race, to take all necessary measures for the verification of the sealing of pieces done by it.
- 15—All attempt at fraud on the part of a contestant will involve the exclusion from the race of the vehicle, and may, according to the circumstances, involve the disqualification of the driver, his mechanic, of the constructor interested and of other vehicles entered by the latter.
- The constructor will have to pay a fine of 10,000 francs, and the Sport Committee will decide the duration of the disqualifications incurred.
- 16—All vehicles will carry, obligatorily and as a maximum, two occupants side by side, of a mean minimum weight of 60 kilograms for each, it being understood that where this mean weight is not reached the surplus must be supplemented by ballast.
- 17—The contestants will not be permitted to take part, unless on the day of weighing-in they are provided with the document issued by the Ingenieur des Mines, attesting that the vehicles entered by them satisfy the legal requirements.
- 18—All vehicles entered must have:
  - (1) A reverse gear actuated by the motor.
  - (2) An exhaust pointing horizontally rearward and sufficiently high to avoid stirring up dust.
  - (3) No vehicle broader than 1.75 meter can take part in the race.
- 19—The vehicles taking part in the race must, according to the nationality which they represent, be painted in the following colors: Germany, white; America, white and blue; England, green; Belgium, yellow; Spain, yellow and red; France, blue; Italy, red; Switzerland, red and white.
- 20—*Weighing-in.*—A regulation concerning especially the operations of weighing-in will be published later. Its provisions will be made known betimes to those interested.
- 21—*Repairs and replenishments.*—Repairs and in general every other operation must be made exclusively by the crew of the vehicle.
- Use of the removable or dismountable rim and of the dismountable wheel is permitted.
- Replenishments—oil, fuel, pneumatic tires and spare parts—can be taken on board only at one or two places of the course, designated in advance, and every infraction of this rule will involve the exclusion of the vehicle from the race.
- The exclusion from the race will also be applied to every vehicle departing voluntarily from the course.
- Each firm will have the right to a section, drawn by lot, at the replenishment station or stations.
- 22—Firms which are not competing, but, nevertheless, interested in the race and desirous of occupying a section at the replenishment stations must pay a fee of 1,000 francs.
- Requests for these sections must be accompanied by the fee mentioned and will be received by the Sport Committee of the Automobile Club de France until December 30, 1911, 6 o'clock evening. Such requests at double fee will be received until March 1, 1912, 6 o'clock evening.
- 23—*Drivers.*—The drivers and mechanics of each vehicle may be changed during the race, but only at the end of each lap and under the surveillance of a commissary.
- The reserve drivers must be designated before the race to the Sport Committee.
- The mechanic may replace the driver at any spot of the course, but only in case of duress (fatigue, accident, etc.).
- 24—The Sport Committee reserves the right to exclude any driver for reasons bearing upon the security of the public or of other contestants.
- As soon as the constructors shall have engaged drivers for their vehicles it shall be their duty to make them known to the Sport Committee by registered letter, accompanied with an agreement of the following form:
 

Between the undersigned, Mr. X, constructor of automobiles, and Mr. Y it has been agreed as follows:

Mr. Y agrees to drive in the Grand Prix of the Automobile Club de France in 1912 a vehicle of the make X.

Mr. X, constructor of automobiles, binds himself to furnish, for this race, to Mr. Y a vehicle of the make X.

Signed X and Y.
- By this arrangement, the driver will not be able to drive a vehicle of another make, unless the two parties agree to rescind their contract, and, in that case, the Sport Committee must be kept advised of the change.
- 25—The driver and mechanic of each vehicle entered must possess certificates of competence to drive automobiles.
- 26—*Starts.*—The order of starting in the race shall be decided by drawing lots.
- The hour for starting the first vehicle on the first day and the intervals between starts will be determined later.
- On the second day, the vehicles shall start in the order of their arrival and with intervals to be decided upon later.
- The time for closing the race (on the first and second days) will be decided by prefectorial decree.
- Under all circumstances the commissaries of the race shall have the right to stop the vehicles before the hour fixed.
- 27—*Parking.*—Every vehicle having finished the course of the first day within the prescribed time limits will be placed immediately thereafter under the orders of a commissary charged with watching it and conducting it in the park.
- After the motor is stopped, the driver is permitted only to close the fuel and oil valves, if need be, and the vehicle will be parked by hand power.
- Each vehicle will be placed in a separate compartment and nobody will be permitted to approach it before the hour for starting on the following day.
- On the morning of the second day, the vehicles will be placed in the hands of their respective crews at the moment of departure for each of them.
- No operation bearing upon the start of the motor, on replenishment of supplies, on repairs, etc., can take place till after the signal for starting shall have been given, and the time used for this purpose shall be counted as running time.
- 28—*Protests.*—Every protest must be made in writing and placed in the hands of one of the commissaries of the race during the hour following the closing of the control stations.
- Every protest, in order to receive consideration, must be accompanied by the sum of 100 francs, which will not be refunded to the claimant unless his protest is recognized as well founded.
- 29—The contestants agree, in case of dispute, to recognize only the jurisdiction of the Sport Committee and in no case to have recourse to the courts.
- 30—*Responsibilities.*—Civil and criminal responsibilities of all sorts are borne by the contestants to whom they relate.
- 31—*Insurance.*—It shall be the duty of all constructors engaged in the race to provide for insurance against accidents of all sorts to third parties, which may be caused during the race, and also against fire, covering direct damages as well as all recourse action relating to merchandise, fuel and material deposited at their replenishment section.
- To this end, it shall be the duty of constructors to mail to the Sport Committee by registered letter and one month in advance of the date of the contest, duplicate of the policies which they have signed.
- On the day of the race the Sport Committee would refuse to start any contestant having failed to comply with this requirement.
- 32—*Application of the Rules.*—By the fact of his entry, the contestant agrees to conform to the provisions of these regulations and the decisions of the Sport Committee.

33—All points not provided for in the present regulations will be decided according to the general racing regulations of the Automobile Club de France.

34—The Sport Committee of the Automobile Club de France remains sovereign judge of the application of the present regulations and reserves the right to modify them as event may dictate.

### Boycott for 1912 French Grand Prix

Immediately after the official publication of the regulations which the Sport Committee of the Automobile Club de France had adopted for the Grand Prix and Coupe de l'Auto races in June, 1912, a despatch from Vienna announced to the astonished leaders of the once powerful club that their kind invitation to the automobile industries of other countries, once more to come and cross arms with the industry of France on French soil, had not met with the glad and eager response which was accorded to similar invitations in former years, before the foremost French houses concluded to stand pat on their dignity and refrain from racing. The despatch stated briefly that a number of German manufacturers had signed an agreement to boycott the French Grand Prix race.

Inquiries made by wire in Berlin brought only confirmation of the news. The Benz, Mercedes, Adler, N. A. G., Opel, Protos, Dürkopp and Bergmann firms had all signed a contract binding each and all to permit none of the cars of these makes to take any part in the French Grand Prix race of 1912, and in the nature of things the boycott included the Coupe de l'Auto race to be run in conjunction with the Grand Prix under a separate classification. Moreover, the Belgian firm La Metallurgique, it was found, had made common cause with the Germans.

The Fiat concern of Italy, on the other hand, had refused to sign any pact, either to participate or not to participate, but at the last account had sent no entries to the Sport Committee in Paris.

### Protest Against Fairmount Race

PHILADELPHIA, Dec. 14—Emphatically protesting against the granting of further authority to hold the annual Fairmount Park road race and questioning the jurisdiction of the Fairmount Park Commissioners to furnish a permit, Dr. J. William White, a member, reintroduced a lengthy resolution to abolish the event.

That the event was dangerous to the lives of both participants and spectators; was but a scheme of manufacturers, serving no good end, in that racing had no value in the development and improvement of motor cars; that the example set by racing drivers tearing off 90 miles an hour was likely to have a detrimental effect on weak, ill-balanced persons by creating a desire to emulate the speed kings; that only remarkably good fortune had so far prevented tragedies in the Park and that the chief element of interest in it is the always-present chance of accident—these are but a few of the many objections enumerated.

Admitting his personal enjoyment of these races, Dr. White said that his pleasure was marred because "by reason partly of my vote in this commission, an uncertain number of persons (among them women and children), who were by our act encouraged to be present, might be instantly killed during one of these races, and because no conceivable precaution could eliminate this possibility.

"The fact that in our races the altogether admirable management, the fine work of the police and of the Park Guards, and the amenability of the spectators to discipline, combined with good luck, have hitherto enabled us to escape without serious accident does not invalidate or even weaken this argument. There can be no possible assurance that this good fortune will continue.

"Before I introduced this resolution I made an effort to ascertain the state of intelligent opinion on the subject; I submitted the matter to the members of a literary club, to the board of a financial institution, to a large committee made up of medical men and to a number of individuals, some of whom were connected very closely with automobile affairs. Nine-tenths of those

to whom I spoke owned cars. They were asked in each case whether or not, if they had the authority and the responsibility of the Park Commission, they would or would not support the resolution. Those who said they would not were in a numerically negligible minority of not more than 2 per cent. A well-known member of the Bar, Mr. George P. Rich, is of the opinion that we have no legal right to permit these races, that an injunction against them would hold, and that in case of damage to person or property we would be legally liable."

As to minor matters, such as injury to Park roads, turf and shrubbery, no complaint is made because "the benefits of a day's outing to the owners of the Park—the people themselves—would more than compensate for this disadvantage, especially as the roads are put in order again by the promoters of the race."

"Inquiry has led me to believe that the races have little or no value as tests of automobiles," says the doctor, "that they chiefly subserve the interests of a small minority of manufacturers; that there are other and harmless ways of trying out engines and tires, and running or steering gear; and that even races may be held—but not on public roads—with far less danger to participants and none to spectators. I am also strongly inclined to think that these particular races involve a disregard of the rights of some of our citizens who will, I know, in the future, ask the courts to protect them."

The resolution has been referred to the Committee on Superintendence and Police for report. In the meantime Dr. White's broadside is met by the convincing arguments that in the four races so far held here under the auspices of the Quaker City Motor Club and the municipal authorities not an accident of any kind to spectator or driver has occurred; that the Park course has been proven safe; that the annual turnout demonstrates its popularity; that the statement that persons are attracted by the element of danger is not borne out by the facts, and that Dr. White's suggestion of a municipal race track is not feasible and couldn't begin to compensate for the attraction of a race in the picturesque and easily-accessible Park.

### 1912 Racing Season Promises Activity

NEW YORK, Dec. 14—At a meeting to-day of the contest board of the American Automobile Association it was decided to send out letters to all of the clubs and promoting organizations throughout the country, asking them to select dates for their coming contests for the 1912 season, with the object of enabling the board at its next meeting to issue the first draft of the 1912 calendar. Already Indianapolis has asked for Decoration Day and Labor Day for speedway races; Philadelphia has put in a bid for the second Saturday in October for the Fairmount Park 200-mile road race; application has been received from California for a date about the middle of May for the Santa Monica races, and a request has come from Chicago asking for dates in August for the Elgin races. From present indications it would seem that 1912 will be an active one in the road-racing field.

Several drivers came under the ban of the board for participation in unsanctioned events. T. S. DUBY was suspended as a driver for two years for competing at De Witt, Iowa, September 15, under the assumed name of Bliss at an unsanctioned meet. C. B. Kent was given six months' suspension for competition at an unsanctioned meet at Madison, Wis., September 24. Application from the New York Motor Club for reinstatement by the board was received but no action was taken. This club was suspended for conducting an unsanctioned meet on July 4.

The board received from the Manufacturers' Association a number of recommendations for changes in the 1912 rules. The different members of the board have suggested many alterations and it is expected that the final draft of rules governing 1912 contests will be completed during the New York show season.



Fig. 1—A portion of the coach department in the new Packard service station in Long Island City

## What Makers Are Doing for Buyers

### As Illustrated by New York Packard Service System

At the junction of Thompson avenue and VanDamm street in Long Island City, the Packard Motor Car Company, of New York, completed in October, 1910, the pioneer service station in the metropolitan district—that is, speaking of service as a feature distinct from all other branches of the automobile business and as entitled to a home of its own.

This location was chosen with great foresight. The building faces Diagonal street viaduct over the Sunnyside yards of the Pennsylvania Railroad, the air-line from Queensboro Bridge Plaza to Thompson avenue, which is the main artery for automobile traffic from Manhattan to all points on Long Island. Being thus situated, it cannot escape the observation of the great army of Long Island com-



Fig. 2—Exterior view of the building, showing the modern tile and glass construction

muters who daily pass through the busy railroad yards.

The distance of the service station from the company's main office in New York City is 3 miles, an easy 15-minute run by automobile. A delivery service is operated between the two points, carrying passengers, stock, inter-department communications and the like, on a regular schedule of five round trips a day. Telephone tie lines weld the two offices almost into a unit and provide immediate communication on all subjects of mutual importance—a big factor in service efficiency.

The building is thoroughly modern in every respect. It is approximately 150 feet long by 100 feet wide and is constructed of steel, hollow tile, concrete and glass, there being about 24,000 feet of the



Fig. 3—A portion of the body painting department on the fifth floor. Job costs for this department are made up at the right

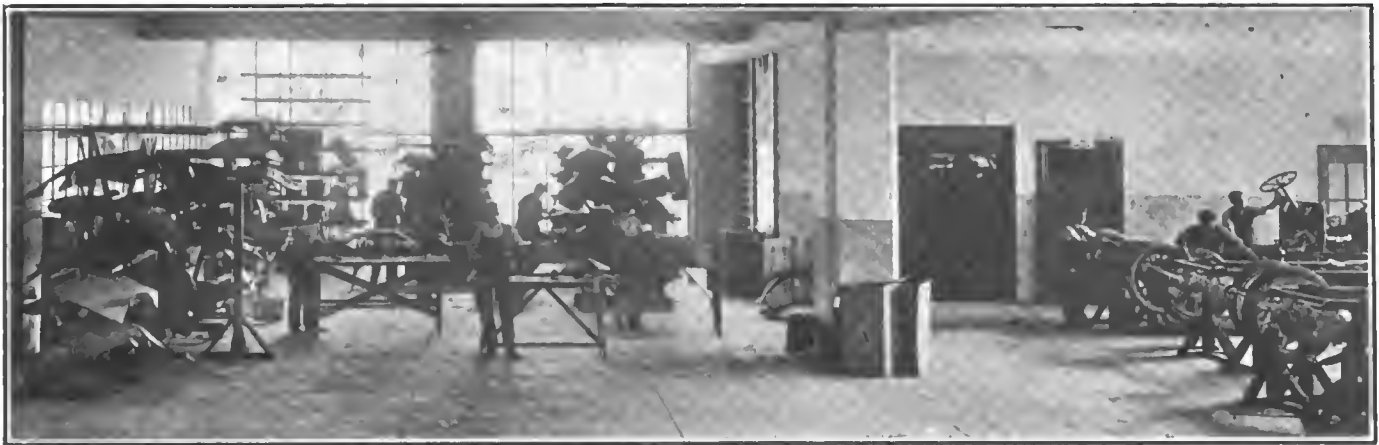

Fig. 4—A corner of the paint-shop is given up exclusively to fender painting. Note the drying racks

last-named material. Eight floors and a basement make up an available floor space of about 200,000 square feet. Some idea of the size of the plant may be gained from the fact that there is room for about 200 cars and 35 trucks in simultaneous process of repair, together with 45 cars and 100 car bodies in dead storage.

#### Special Features of the Building

Despite the fact that the building is of rigid fireproof construction throughout, there is a most elaborate sprinkler system. A roof tank stores continually 40,000 gallons of water for sprinkler service, and in the basement is a reserve tank containing 75,000 gallons more. These two tanks are inter-connected, and in case of fire, a powerful pump will raise the basement supply into the tank on the roof.

Gasoline is stored in underground tanks outside. These tanks are four in number, of 500 gallons capacity each, connected with pumps located in a small, fireproof outhouse. Oils, kerosene and turpentine are kept in the basement in 150-gallon tanks, the delivery pumps being on the first floor.

Besides the passenger elevator at the east end of the building, there are two freight lifts in the southwest corner. The latter are 12 feet by 17 feet, with capacities of 8,000 pounds and 15,000 pounds, respectively. These do all the heavy lifting, trucks being carried on the 15,000-pound elevator, while pleasure cars and freight are raised on the one of less capacity.

#### How the Space Is Utilized

It is interesting to note the way in which the large amount of space in this new service station has been used. The eighth

or top floor is devoted entirely to truck repairs, and has a capacity of 35 vehicles. It was chosen for this purpose because only a single row of pillars was required to support the roof, leaving a clear space on the north side approximately 66 feet by 150 feet in which to maneuver the bulky commercial cars. The overhead clearance is 15 feet, which is needed to accommodate the taller truck bodies. Like the other floors, it has three full sides of glass, but it differs from them in that it also has a skylight, making an exceedingly well-lighted workroom.

The seventh floor is given over to car repairs, with room for thirty-five machines. On the north side, where the light is best, is the "motor line," or series of horses to hold complete motors during the process of overhauling. Cranes are used to lift the motors from the car frames to the horses. Back of the latter stand the dismantled chassis. Here clutch, transmission and miscellaneous work is carried on.

On the south side are placed the cars which need only slight repair, and here the radiator repair men also work, the few machine tools required being located next to the south windows.

The coach department makes use of the fifth and sixth floors for woodworking, carpenter work, chassis painting and lumber storage. Forty cars can be accommodated on the fifth floor, while the sixth has room for forty-five. At the west ends of both of these floors will be found two banks of lockers in which is stored customers' property removed from cars in process of repair. The office of the coach department is at the east end of the fifth floor, and in it are made up the job costs for this class of work in a manner identical with that employed by the repair department. Along the north side of this floor are the assemblers, while the trimmers occupy the south side.



Fig. 5—Chassis painting section. Each group of painters devotes its time to work on one particular part of the Packard machine



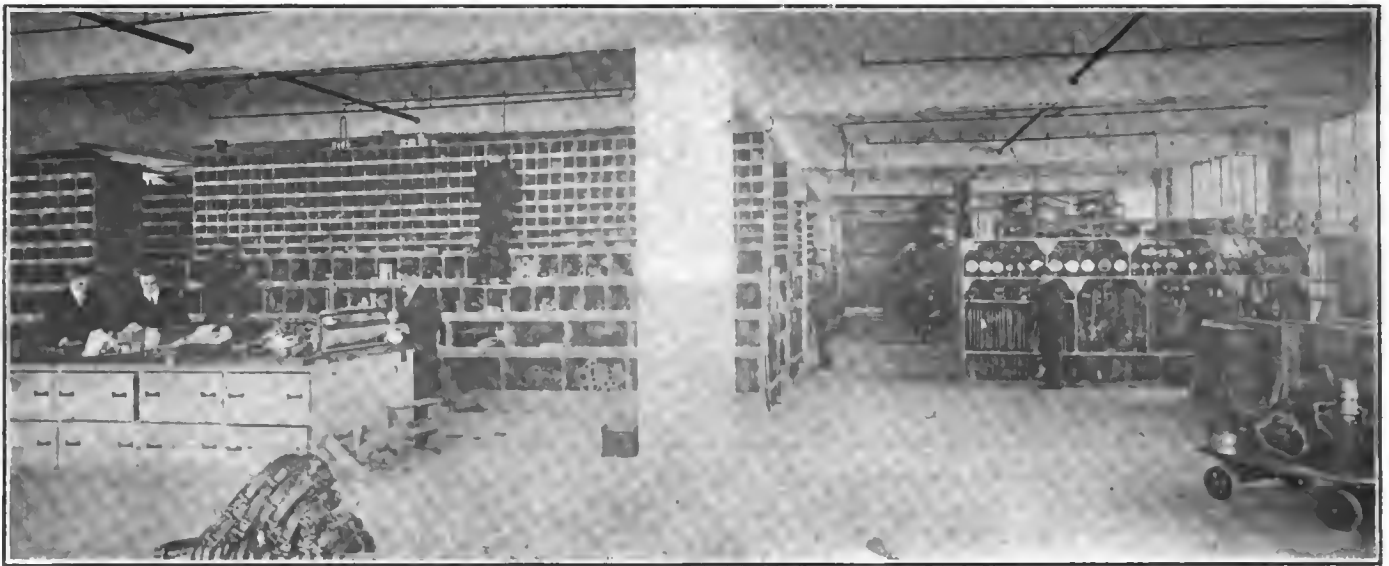

Fig. 6—The stockroom occupies the entire second floor. In it are kept parts for every model since 1904

Painting is done on the fourth floor, which has a capacity of thirty-five cars. Bodies chiefly are painted here, though chassis that cannot be accommodated on the sixth floor are taken care of. Along the north wall at the east end, where it gets light on two sides, is the varnish room, in which the finishing coats are applied under dustless conditions and at uniform temperature. The frame workers, whose work is devoted exclusively to windshields and limousine window frames, and the paint mixers are within an inclosure on the south side next the freight elevator.

The third floor is devoted to dead storage, there being room here for forty-five cars and 100 bodies, as already stated. Along the east, north and south sides are racks of special construction, providing for two tiers of bodies, either open or closed. Cars are stored in the center of the floor and are arranged with a view to convenience in the matter of shifting.

The entire second floor is given over to the stockroom. Within an inclosure of some 13,000 square feet is stored the supply of parts and accessories necessary to provide for the Packard owners throughout a wide range of territory. At the east end of the inclosure is the customers' window and at the west end of the floor, outside, is the receiving and shipping department, to which all incoming shipments are delivered, and from which all outgoing orders are sent.

Forty-five cars can be accommodated on the first floor, which is used for quick service, storage of finished machines awaiting delivery and the like. At the east end is located the superintendent's office, with accommodations for stenographers, telephone operator, checkers, etc. The south side is taken up by four vehicle entrance doors, one to each freight elevator and one at either end of the floor proper.

#### The Packard Service Methods

A description of the Packard service methods must begin with the stockroom. For service efficiency a stockroom must have an adequate supply of all parts and accessories for which instant demands occur.

This Packard stockroom must provide for the needs of its two fellow service departments, the repair shop and coach department, for customers' direct orders, for stock orders from the New York stockroom and for the branches at Newark, N. J., Hartford, Conn., and Springfield, Mass. In a word, it is the central distributing point of the New York company.

The orders of the repair shop and coach department are presented in the form of requisitions chargeable to repair orders in hand as hereafter described. They come in duplicate by way of a dumbwaiter running between the floors. One man is



Fig. 7—The pleasure car repair shop. Men working on the motor are stationed nearest the windows to get the benefit of all the light possible





Fig. 8—View in the dead storage department. Racks are provided for the storage of two tiers of bodies, as shown

delegated to receive them and follow them through for quick delivery. It is his duty to act as personal representative for the other two departments, and if there are delays or errors in filling requisitions, he is the responsible party. He rarely fills requisitions himself, but stays at his post to receive them, to hasten the men who do fill them and to check the filled orders for accuracy. His location is such, in relation to the customers' window, that he can serve it after the same fashion.

Customers' and branch orders are handled after much the same methods as those employed by any well regulated plant. A record of each order of any sort is made on a perpetual inventory, which is charged with all stock received, credited with all delivered and posted with the date and quantity of every order. It is subdivided according to models and each part of every year's car has its danger limit. The interchangeability of parts, which is a feature of the company's construction policy, tremendously reduces the number of individual entries in the record, but it nevertheless entails an immense amount of work.

When the order calls for work that will detain the car for from two days to several weeks, the check includes everything in detail and a copy is sent to the customer with a request to report promptly any shortages noted. When the order calls for short jobs only, the check includes merely the readily removable

equipment. Copies of all complete checks are interchanged between the New York office and the service station. Discrepancies at either point are immediately investigated.

Cars come from the New York office accompanied by orders and checking sheets, all of these typewritten with four copies. The repair shop receives one, the coach department two and the head tester, who is also finished inspector, one. Frequently the attention of but one department is required, but it is necessary for each to have its own record of the order, as either department may be called upon for work by a supplementary order.

After being "checked in," each car is sent to the floor where work on it is to begin. Cars to be stripped or relieved of light equipment are handled first by the assemblers, who remove whatever is to be locked up for protection and place it in the lockers already mentioned. The car is then delivered to either the repair or coach department according to the nature of the work which is to be performed.

It is seen that the Packard Company has worked out its system well, such exhaustive methods being necessary on account of the volume of its business. In an ordinary month there are approximately 400 cars and trucks which apply at the plant for repair of one form or another, and the company's aim is to meet this demand for its service in as satisfactory a way as possible.



Fig. 9—A large section of the coach department is devoted to upholstery and top making

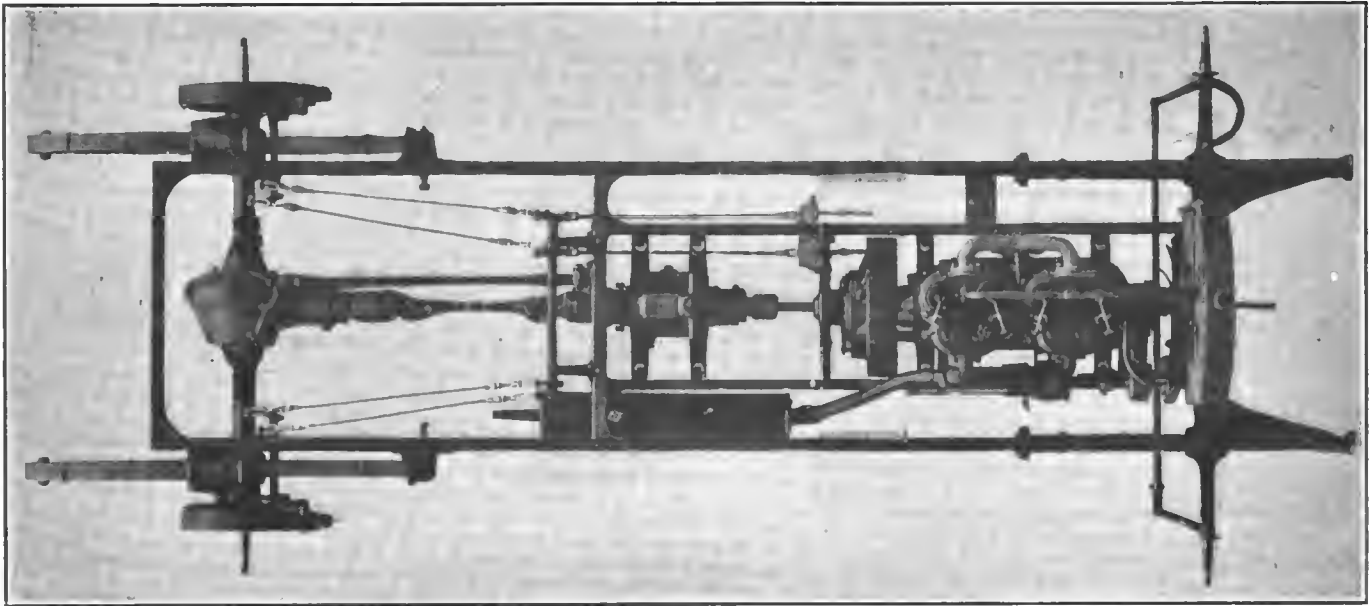

Fig. 1—Chassis of the Olds production known as Reo the Fifth; standard for all types of bodies

## Reo the Fifth--Olds' Latest Model

**W**HAT is announced as the greatest achievement of R. E. Olds has been brought forward under the name of Reo the Fifth. It is fitted with a 30-horsepower motor and the chassis is provided with bodies of the five-passenger touring, baby tonneau and two-passenger roadster types.

The motor has four cylinders, which are cast in pairs. The water jackets are cast integrally with the cylinders and are of large dimensions to insure a positive circulation and avoid pockets in the cooling space. The motor is illustrated in Figs. 2 and 3, which show the left and right sides of the motor respectively. The bore of the motor is 4 inches and the stroke 4 1-2 inches, giving a stroke-bore ratio of 1.12. The intake manifold is of the Y-type and connected to the cylinders by means of stud bolts which pass through flanges on the intake manifold and into bosses cast integrally upon the exterior of the cylinder walls. The water intake pipe is led to the gas intake side of the motor through the small pipe shown in Fig. 2, and this is connected in a similar manner by means of flanges and stud bolts. The intake manifold is flanged at the Y and is so designed that as it leads from the carburetor to the Y it tapers gradually from a circular section to an elliptical section, the area being constant for the whole of this distance.

The inlet valves are located at the top of the cylinders and are operated by means of rocker arms driven off the camshaft. The rocker arms are located above the cylinders and may be readily seen in Fig. 3. The method of their operation is also shown in this illustration. The rods extend directly from the crankcase to the rocker arm and may be adjusted by the nuts located at the point where the rods enter the lower part of the crankcase casting. Stuffing boxes are located at this point in order that the oil does not leak from the base chamber to the exterior of the motor and give the same a dirty appearance after the motor has been running for a short length of time, not to mention the waste of oil which very often occurs from this point. The springs for the inlet valves are located on the upper part of the cylinders upon which they seat and are of sufficient strength to operate the rocker arms positively to preclude lost motion in the inlet valve mechanism.

The exhaust valves, located on the right side of the cylinders, are surrounded by the water jacketing to keep the parts, which are submitted to the excessive heat of combustion, as cool as possible. In order to make the cooling of the valve ports as certain as possible the water is led directly from the water intake to the exhaust valve and from there is allowed to circulate through the remainder of the jacketing. The exhaust manifold is connected to the cylinders in the same manner as the intake manifold. Larger bolts are of course used to sustain the greater weight. The manifold droops downward in a slow curve at the rear end so that there will not be any excessive back pressure produced at this point. The exhaust valve stems are upon the same side of the motor as the rods which operate the rocker arms for the intake valves. The adjustments for the valves are made in the same manner, the device consisting of a nut above

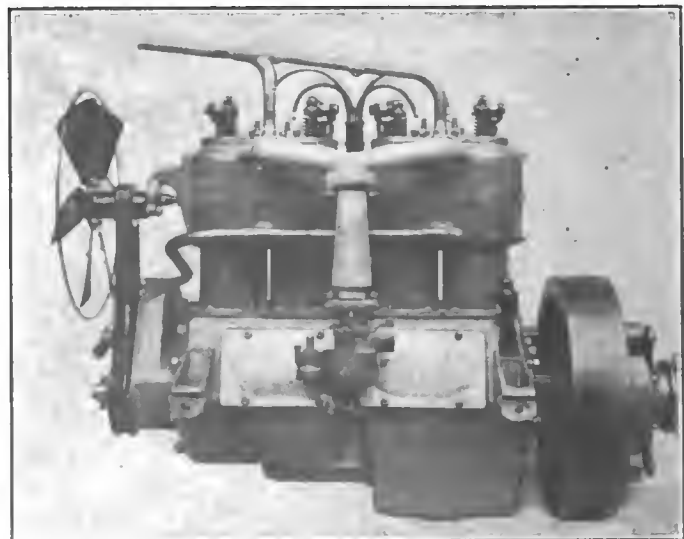

Fig. 2—Left side of the latest Reo motor

which there is a sort of cup in which the tappet rods rest. When there is any lost motion due to wear these nuts are turned in order to take up the space between the cup and the end of the tappet rods when the cams are at the lowest point. These points of adjustment are very accessible and are all upon the same side of the motor and at the same height so that they may all be inspected at the same time and the adjustment so regulated that they will be the same for each of the valve stems. In order to facilitate the inspection of the valve operating mechanism there is a cover plate over the lower part of the crankcase, which, when removed, discloses the entire cam action. This cover plate is held in position by means of stud bolts and dogs which pass over the cover plate. The stud bolts, of which there is one to each dog, pass through the center of the dogs and through the metal of the crankcase into bosses in the metal.

When it is desired to inspect the cams for wear or in case of trouble with these parts the bolts are removed; the dogs are then lifted out of place and the cam action is disclosed. The camshaft itself may be inspected or cleaned through this opening. The camshaft bearings may be removed through the opening, without disturbing the cams, by simply unscrewing the cover plates of the bearings. Inspection for wear in these places may be readily made in this manner without the expenditure of a great amount of time or labor.

The pistons are of gray iron castings, as are the cylinders, and are fitted with three sprung rings above the wristpin. The latter member is of steel and is provided with a bushing to take the bearing at the upper end of the vanadium steel connecting-rod. This is made as long as is consistent with a low engine, in order to reduce the thrust on the side walls and at the same time to keep the center of gravity of the car as low as possible. In order that the connecting-rods may be reached without removing the cylinder castings from the crankcase, there are hand-holes in the latter casting by means of which they may be examined and any adjustments readily made. Adjustments on the crankshaft bearings are made from the exterior of the motor, hence there are no assembling operations necessary after these adjustments have been made.

The cooling-water is circulated by means of a centrifugal pump located at the front end of the magneto shaft, which is extended forward for a considerable distance beyond the extremity of the crankcase on the right side of the motor. It is attached to the radiator by means of a short rubber tubing and draws the water directly from it. The water is then led through a nickel-plated tube to the opposite side of the motor and thence to the water jacketing. The outlet manifold is placed upon the

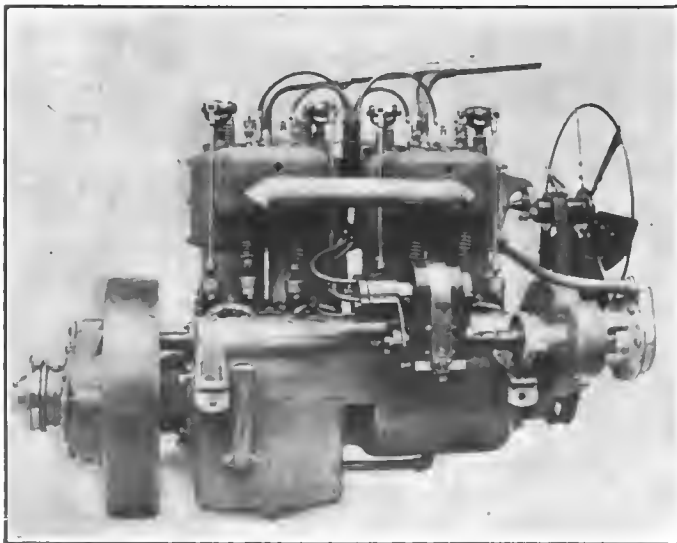

Fig. 3—Showing the right side of Reo motor

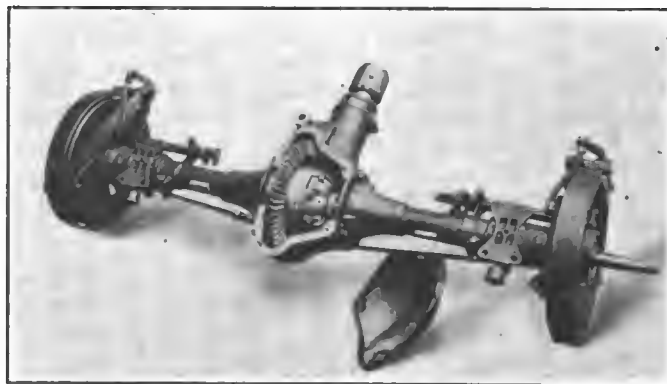

Fig. 4—A view of the rear axle with cover removed

top of the motor and slopes gradually upward to the top of the radiator, which is of the vertical tube type.

Lubrication is effected by means of a combination of the force-feed and splash systems. The oil reservoir is located in the lower part of the crankcase casting, which is of aluminum. The main supply of oil is carried in the tank formed by the depression of this casting, the capacity being in the neighborhood of 3 quarts. The filler hole is located on the right side of the motor near the rear end and is placed on the end of a tube which is an integral part of the filler. This filler tube is cast with a flange at the bottom by means of which it is held to the bottom of the crankcase by two bolts which pass into the base chamber. There is a screen in the filler hole through which all the oil must pass that is poured into the tank; this will insure a clean supply of oil to the tank at all times so far as any impurities which may be in the original supply are concerned.

The oil is taken from the tank by means of a plunger pump and led through the main lead to the main bearings, which are thereby lubricated. After passing through the main lead the oil flows into troughs, which are held upon a horizontal tray in the base chamber. These troughs are at such a height that the bottom of the connecting-rods will plunge into the oil for a distance of about 3-8 inch when they are full. The oil is caught up on the projections on the bottom of the connecting rods and beaten into a spray which pervades the entire crankcase, thus lubricating the pistons and all other moving parts within the motor. The camshaft bearings secure a liberal supply of oil by this means and there is at all times a mist of oil within the pistons themselves which will find its way about the oscillating bearing of the wristpin.

Since there is a superabundance of oil supplied by the pump there is no danger of the end troughs running dry either when ascending or descending a hill. However, there must be some means of permitting the excess oil to overflow so that the motor will not smoke. This is provided for by a series of overflow standpipes in the crankcase. The oil will pour through these whenever it reaches a point above the top of the splash troughs, and in this manner again reach the reservoir. In order that the supply be cleaned before it is again circulated through the lubricating system a screen is introduced through which the oil must pass on its way to the pump.

At the bottom of the reservoir there is a drain plug which may be removed for the purpose of draining out all the oil before renewing the supply. A separate oil lead takes the oil from the pump to the timing gear case at the front end of the motor, the revolving gears serving to distribute this oil about the case so that the gears work in oil and are at all times amply lubricated. After leaving the timing gear case the oil flows by gravity to the splash troughs in the same manner as it does after leaving the main bearings. The gearset and the differential are lubricated in the same manner as is usually employed in these parts. They are packed in non-fluid oil and are covered by grease-tight housings.

The carbureter fitted to the new car is so designed as to be

capable of handling either high or low grades of gasoline. It is of the automatic type and fitted with a hot air intake pipe by means of which the gas admitted to the cylinders is kept uniform under varying climatic and atmospheric conditions. It is held suspended from the intake manifold by means of a broad flange and two through bolts which pass through the flange and the gasket inserted between the faces to guard against leakage at this point. Adjustment points are rendered as accessible as possible on the carburetor so that it may be readily set without taking it from the motor.

A low-tension magneto is fitted with supplementary dry batteries for starting purposes. The magneto and coil are of National make and produce a high-tension spark at the plugs. The magneto is carried upon the right side of the motor; it is driven by a short shaft which also operates the water pump upon its other extremity. The timer and coil are connected directly to the magneto, the wires being led straight to the spark-plugs after passing through a tube located between the two pairs of cylinders and fastened thereto by means of a metal strip which passes from the nuts which hold the rocker arms of the two central cylinders, around the tube which carries the wires. The tube is bent out toward the right side of the motor at the bottom, thus leading the wires directly to the magneto without allowing them to rub across any edges which could cause the insulation to chafe and eventually lead to a short circuit. The magneto is held in place by means of a metal strap which passes over it and holds the instrument tightly upon the shelf which carries it. Should it be desired to remove the magneto this can be effected by unscrewing the nut which holds the shaft in place, disconnecting the shaft and then withdrawing the magneto. The batteries or magneto may be used at the discretion of the operator by the manipulation of the switch which is located on the dashboard.

A change has been made in the location of the flywheel; it is set back 2 inches farther on the new model than on the models of the past year so that longer bearings may be used and the tendency toward vibration decreased. The clutch is located in the flywheel and is of the multiple disk Reo type, having alternate disks of bronze and steel. The housing is an integral part of the flywheel and may be seen in either of the illustrations of the motor. The clutch spring is inclosed and held in place by the casing cover, which is fastened by three stud bolts passing into the clutch housing. When these bolts are removed the whole clutch may be readily disassembled for inspection. The clutch is controlled by pedal in the usual manner except that it is manipulated by the left foot. The flywheel is so marked that it is possible to take down the motor and set it up by

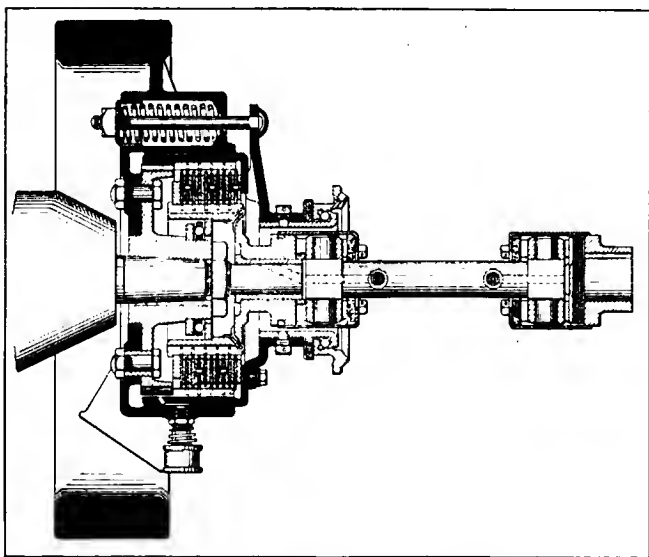

Fig. 5—Detail of the clutch used on Reo the Fifth

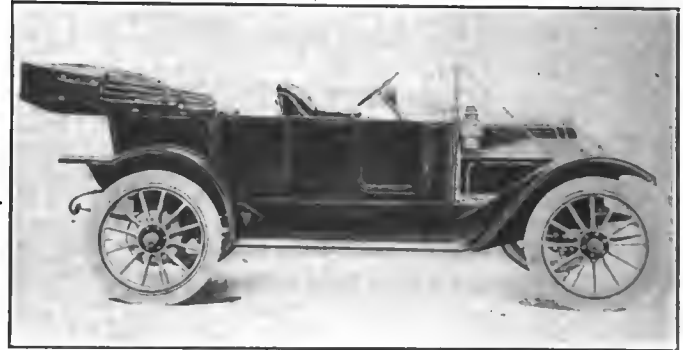

Fig. 6—Showing the five-passenger touring car for 1912

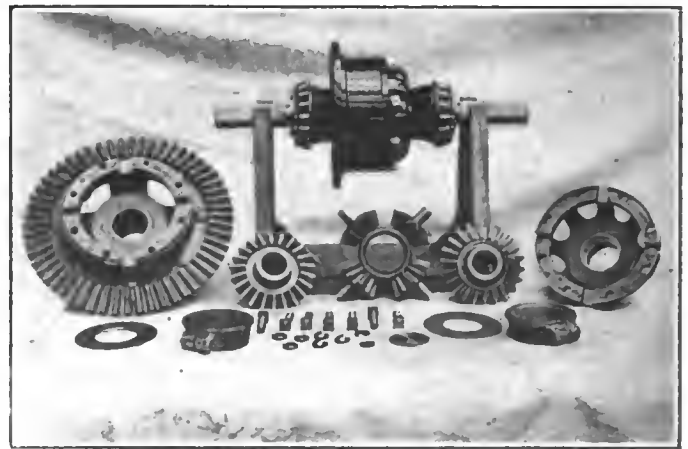

Fig. 7—A disassembled view of the differential gearing

means of these markings and still have the same timing. The marks consist of chisel cuts and the initials of the operation which is taking place at the time that the chisel mark is opposite the indicator on the engine frame. In this manner the opening and closing of both inlet and exhaust valves on all the cylinders are shown as well as the time in which any of the pistons reach either the top or bottom dead center.

The gearset is of the three-speed and reverse selective type. It is of compact design, as may be seen in Fig. 10, where it is shown in section. The gear-shift lever is of peculiar design, being fitted with a ball handle instead of the usual grip type of handle. The lever is located in the center of the car in a transverse direction, being on the right side of the driver, who occupies the left seat in this car. The gearset is very similar to that used on the Reo 1911 cars except that it has Timken bearings on the upper shaft and Hyatt high-duty bearings on the countershaft. The drive shaft is of nickel steel, bar hardened and heat treated; it is separated from the clutch by a universal joint, the casing of which is packed in grease. This joint will take care of any changes in alignment due to road shocks or other causes, and is kept continually supplied with lubricant by the grease which is fed to it through the gearset casing. Drains are fitted in the gearset housing by means of which the gears may be cleaned out and the supply of grease renewed whenever it should become necessary. The maximum travel of the top of the gearshift lever is 3 inches, so that in whatever position it may be located it should never be in the way of the driver. On account of the central location of the lever it is possible to leave or enter the car upon either side in the front as well as in the rear.

The gearset housing may be taken down by removing the bolts, of which there are eight, that hold the cover plate to the main part of the housing. The gear wheels, bearings and shafts may then be readily inspected and removed if it be necessary.

The drive is taken up beyond the gearset by means of a nickel

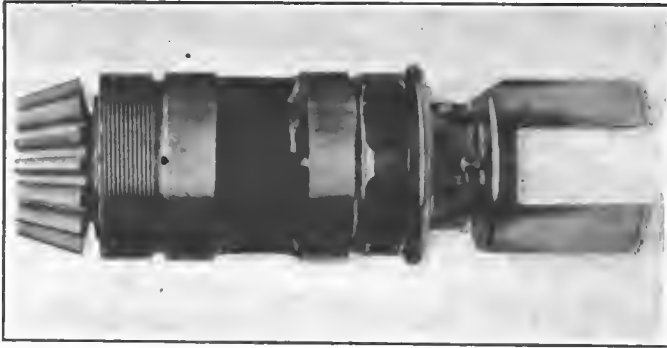

Fig. 8—The drive pinion of the differential is an integral member

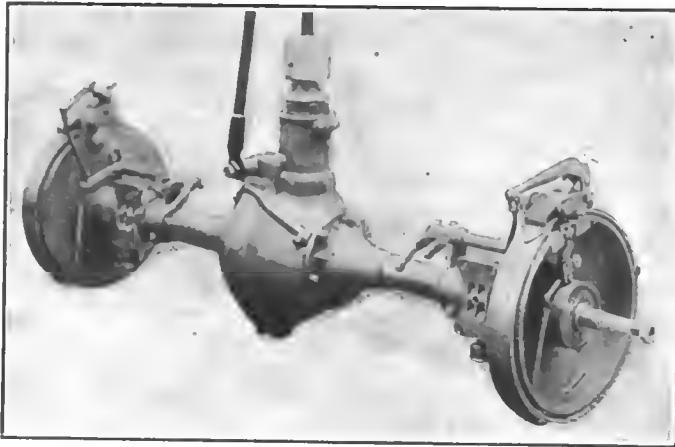

Fig. 9—Illustrating connection of torque rod to rear axle housing

steel propeller shaft separated from the gearset by means of a universal joint of the pin and block type to take care of the changes in alignment due to the varying passenger loads. This universal joint is also inclosed in a casing and runs in a bath of oil. At the rear end of the propeller shaft another universal joint of the same type is fitted and equipped with an oil-tight casing in the same manner as that just mentioned. The power is transmitted through this to the differential housing, which forms an integral part of the pressed steel casing in which the rear axle is contained. Leather boots are fitted over the universal joint casings, thus effectually sealing the part against the intrusion of any dust or grit, and at the same time keeping the part clean in case it is desired to do any work upon the universal joints.

The drive pinion through which the power is transmitted to and differentials is shown in Fig. 8; it is an integral part of the short shaft between the universal joint on the rear of the propeller shaft and the system of gearing in the differential casing. These gears are shown disassembled in Fig. 7; they are of heavier construction than those used heretofore in Reo cars and are made with the idea of noiselessness. To further this end they are carried upon roller bearings of Timken make throughout, while the fact that the drive pinion is connected integrally to its shaft does away with any possibility of lost motion due to wear at this point.

The rear axle is of the semi-floating type, being carried throughout on roller bearings of the Timken type, except that at the wheels the bearings are of the Hyatt high-duty type. Flanges upon the differential casing, to which are bolted the corresponding flanges of the axle shaft casing, form the means of connection between these two members of the rear axle housing. They are both of pressed steel. The accessibility of the differential may be judged from the view shown in Fig. 4, where the cover plate is illustrated as removed from the differential. The gearing, shafts and bearings are exposed sufficiently for the performance of any necessary adjustments. Torque rods are fitted to the rear axle housing for the purpose of stiffening

the structure of the chassis and to avoid all torsional strains when making sharp turns or otherwise placing excessive strains upon this part of the mechanism.

The brakes are shown in Figs. 4 and 9; they are of the external and internal types, working upon 14-inch drums on the rear axle. The service brakes are of the external contracting type and are faced with thermoid. These brakes are operated by means of a pedal from the driver's seat. The emergency brakes are of the internal expanding type, working upon the same drums as the service brakes and faced with the same material. They are also controlled by pedal. Springs are fitted which keep the brake bands from dragging on the drums while they are not in use. Both sets of brakes are equipped with equalizers which distribute the pull on both brakes so that they are applied simultaneously and with equal pressure on the drums.

The frame is of Reo manufacture, the side members being of channel section and of single drop construction. The depth of the channels is 3 9-16 inches with 1 1-2-inch flanges. The front axle is of I-beam drop forged construction, having a single drop; the cross rod is to the rear of the axle. The chassis frame is supported upon 3-4 elliptic rear springs 2 inches in width having seven plates, and semi-elliptic springs in front having the same number of plates and being of the same width. The span of the springs is 38 inches. The steering gear fitted with the chassis is of the gear and sector type.

The wheels are 34 inches in diameter all around, and wheel-base is 112 inches. The equipment consists of three oil lamps, two gas lamps, generator, horn and complete tool and tire outfit for both the four and five-passenger touring models and the roadster.

### British Favor Low-Power Cars

Day by day it is becoming more impossible in England to sell motor-cars of high horse-power. This is not entirely due to the fact that the popular demand of the times is for cars of moderate horse-power. Those who can afford to go to the expense are still keen upon such vehicles. But there is a vast difference between the 40- and 60-horse-powered automobile of to-day and the corresponding type a few years ago. While the modern car gives all the horse-power it is rated for, the oldtime car, with its enormous bore and short stroke, rarely ever gave within more than 75 per cent. of its nominal power. It has been suggested that in order to do away with the present tax on horse-power and still raise a corresponding amount of revenue, the taxation on gasoline should be materially increased.

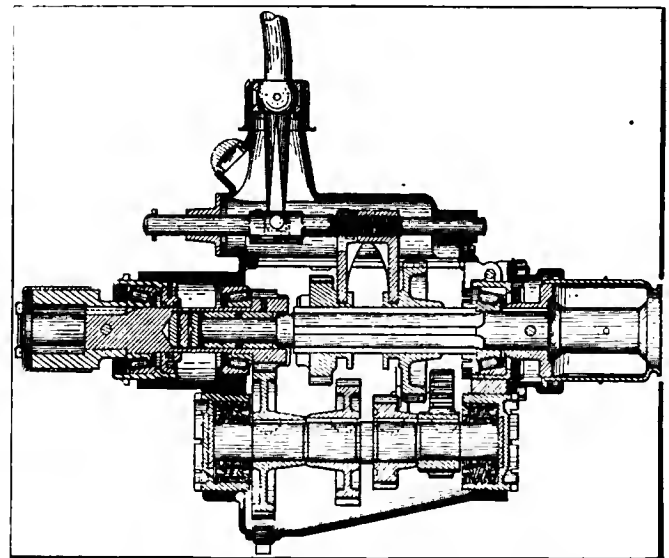

Fig. 10—Section through the gearset of Reo the Fifth



# Destructive Driving-Shaft Oscillation

UNDER certain conditions of design, rapid wear of bevel gear on the rear axle of shaft-driven cars is observed and also of the universal joints on the shaft. And with some frequency it is noted that the ball bearings in which a cardan shaft is mounted at or near its ends, as well as ball-bearings on floating rear driving axles, are injured, without the injury being easily explained by the stresses to which they are considered subject. Some light is thrown on the causes which may be at work, and consequently also on the best means for avoiding the troubles referred to, in an article appearing in a German contemporary and rendered in substance in the following.

It had been observed that many cars equipped with bevel gear and shaft drive became noisy in the rear axle mechanism as soon as the motor speed reached a certain number of revolutions, and Engineer T. Lehmbek undertook to investigate the cause of this phenomenon at the testing laboratory of the German Arms and Ammunition Works at Wittenau, Berlin, in conjunction with Engineer Bockermann, the superintendent of this laboratory. No attempt was made in the experiments to determine the rhythmic effects which may be caused in the operation of a car through coincidence or certain arithmetical relations in the vibrations of various parts with those of the driving shaft, as this would lead to great complications and to results which would not be generally applicable. The object was to decide by graphic methods the general principles ruling the harmful vibrations of driving shafts according to the length of the shafts, their design and the location of the fixed bearings in which the two ends—adjacently to the universal joints—are mounted. The trials were made with plain shafts of different lengths mounted in two ball bearings adjustably secured on the bed plate of a heavy lathe. One end of the shaft was coupled by means of an Eisemann joint with the shaft of a separately mounted electric grinder ordinarily used for micrometric material tests in the laboratory. An intervening expansion pulley drive admitted the variation of the number of revolutions from 500 to 3,500 per minute.

In order to measure the magnitude of the vibration of the shaft at the critical number of revolutions, a measuring apparatus was constructed consisting in a contact lever C with a lever arm ratio of 1 to 10. On account of the momentums this could not be laid upon the shaft, but the end of the index lever was taken in the hand of the operator and the contact point was cautiously approached to the shaft by turning it around its pivot until it was touched by the latter, and this manner of proceeding proved

itself sufficiently exact to insure very accurate determination.

The shaft first used was turned and ground to a diameter of 30 millimeters (1.58 inch) and perfect straightness, and was in all 1,760 millimeters long.

Fig. 1 shows a diagrammatic plan view of the arrangements, together with a side view of the contact-lever apparatus, and it may be noted that the driving shaft A to the right of the coupling B is mounted upon the same bed plate to which the ball-bearings of the test shaft S are secured.

The first series of tests was made with the distance  $L_1$  between the ball bearings variously adjusted to 1,600, 1,400, 1,300 and 1,000 millimeters, and the free shaft ends  $L_2$  were correspondingly 80, 180, 280 and 380 millimeters.

The radius of the oscillations of the shaft resulting under these conditions, and measured at its middle, are shown in the solid lines of the curvograph, Fig. 2. That there is a critical number of revolutions corresponding to each shaft length (between the bearings) is at once noticeable. Soon after this number is reached, the vibrations subside quickly in all cases. By 1,480 revolutions, the radius of the oscillation reaches 8 millimeters, and at 1,570 revolutions only one millimeter more, whereafter it drops. With a shaft length of 1,400 millimeters, the oscillation reached a 7-millimeter radius at 2,030 revolutions. With a shaft length of 1,200 millimeters it required a speed of 2,725 revolutions before the oscillation became 6.5 millimeters and, when the shaft length was reduced to 1,000 millimeters, 3,070 revolutions produced an oscillation of only 2.5 millimeters. The power of the motor was insufficient to reach the maximum oscillation for the shaft lengths 1,400, 1,200 and 1,000.

In the second series of experiments it was the object to ascertain what effect the free ends of the shaft have upon the oscillations of the latter, and for this purpose another shaft of 1,850 millimeters length was employed. The bearings were placed 1,750 millimeters apart as in the first series. Subsequently, the shaft was made 250 millimeters shorter for each successive test, and the distance between the bearings was reduced the same, so that the free ends remained at the same length of 50 millimeters in all the tests. The curves shown in broken lines in Fig. 2 indicate the results recorded. The oscillations were plainly much less pronounced than in the first series.

In practice the conclusions of the experiments may be summarized as follows:

First, when the cardan drive shaft is mounted (in ball bearings) as close as possible to its ends, the calculation of the critical number of revolutions may be made according to Stodola's formula for a freely suspended shaft, but it is possible that even such short shaft ends as those of 50 millimeters, used in the second series of tests, exert an appreciable influence.

Stodola's formula calculated for steam turbines gives the critical number of revolutions as numerically equal

$$r \times 10^4 \text{ to } \frac{L^2 \times 1633}{r \times 10^4}$$

in which  $r$  is one-half the diameter of the shaft and  $L$  one-half the length of the shaft, both in centimeters. In applying this formula,  $L$  is to be considered as one-half the length between the ball bearings; that is, one-half of  $L_1$  in Fig. 1.

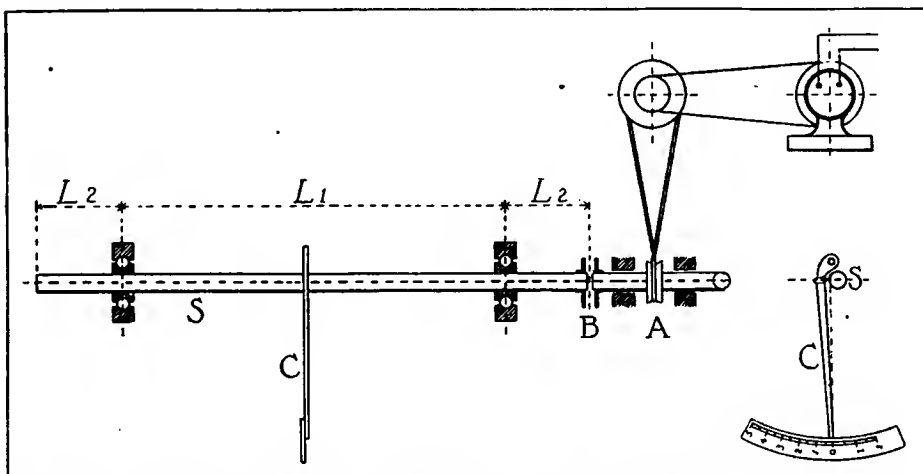

Fig. 1—Grand plan of arrangements for testing end-driven shafts for oscillation—with separate side view of contact index device

Secondly, the longer the shaft ends are which project from the ball bearings to the power at one end, and to the work at the other, the greater will be the oscillations of the shaft and the greater the loss of efficiency.

At the lower end, all cardan shafts are quite closely coupled with the small bevel gear pinion, but at the upper end there is frequently a considerable length projecting, and this explains why so many cardan shafts oscillate violently. In some cases the oscillations become so pronounced that the shaft strikes the enclosing tube and in the course of time spins it into the shape of a taper, as may be observed in a certain French construction. In some Adler cars with long cardan shafts the tube is flanged and joined at the middle to make room for a special ball-bearing to support the shaft at this point. Other constructors use lignum vitæ bearings, but with less satisfactory results.

With regard to the design and workmanship of the shafts, it is of the first importance that they are perfectly straight, so as not to have oscillations from the start. Shafts which have not been turned will rarely run straight, and the slightest incipient oscillation causes an extremely rapid increase of the oscillation radius and soon results in the complete destruction of the ball-bearings at the ends. A good cardan shaft should be accurately turned with the diameter increasing toward the middle, and it is false economy to choose the dimensions too small, as a thin shaft of course vibrates much more than a heavier one and in course of time surely destroys every part coming in contact with it.

Further, a tubular shaft can probably never be made so uniform in the thickness of its walls as is required to avoid that centrifugal forces make themselves felt. The centrifugality starts the oscillations and then, when the critical number of revolutions is also reached, the destruction of even the most substantial ball-bearing is only the work of a moment.

With regard to the location of bearings, the practice of providing these, in the case of a simple cardan shaft, only at the lower end, while leaving the upper end at the universal joint unsupported, is to be condemned. To be sure it works as has been demonstrated often enough, but in that case the universal joint itself must be securely mounted in bearings and must be of very generous dimensions in order to resist the extremely high stresses which are set to work through the oscillations.

Oscillations of the cardan shafts may be recognized by the humming of the shaft at the critical number of revolutions and also by the noise suddenly emanating from the bevel gear on the rear axle; the cause being simply that the oscillations alternately increase and diminish the stresses in the mesh of the gear teeth.—From *Zeitschrift des Mitteleuropäischen Motorwagen Vereins*. No. 21.

### Three Cents a Mile for Car Operation

How much does it cost to run a 15-horsepower motor car 15,000 miles in one year? Here are some figures, based on actual facts, from experience and submitted by Mr. D. C. Defries, chairman of the Motorists' Mutual Co-Operative Society of England.

Tire replacement.....	\$173.56
Petrol, 750 gallons at 27 cents the gallon.....	202.50
Lubricating oil, 50 gallons at 41 cents the gallon.....	20.50
Full insurance against all risks.....	45.00
Sundries (about).....	25.00
<b>Total .....</b>	<b>\$466.56</b>

The above figures do not include chauffeur's wages and garage hire. But Mr. Defries assumes that a man who does not employ a chauffeur, the work of cleaning the car being done by his gardener, should be able to run his car 15,000 miles on an outlay

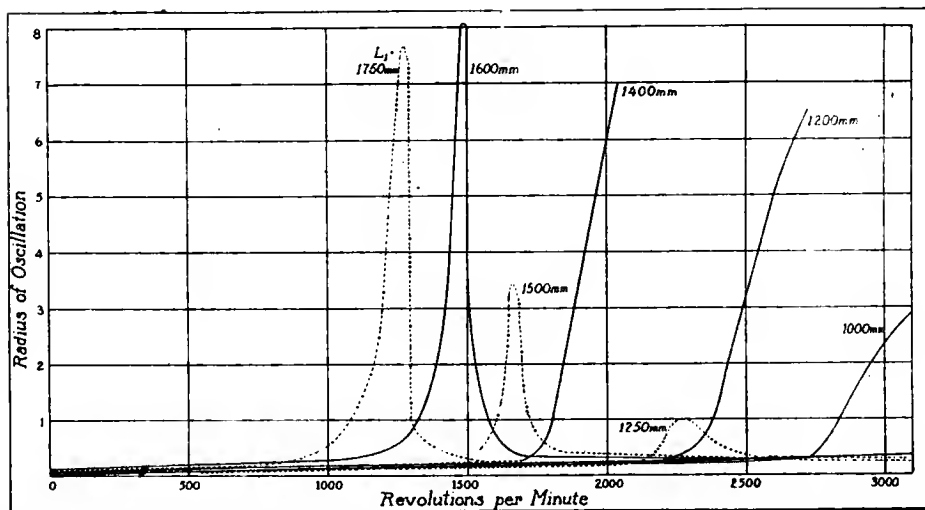

Fig. 2—Diagram of shaft oscillations in two series of tests. Figure at peak of curves indicates length of shaft between bearings

of less than \$500 for the year. This amount of mileage per annum in England is nothing out of the ordinary and especially among physicians, who make strenuous use of the automobile in their professional circuits. One of the American automobile engineers who visited England during the Olympia Motor Car Show is quoted in the press as having designated 5,000 miles as the average year's run of an automobile in the United States.

### British Motor Imports Increasing

The following tables show the amount of British imports, exports and Foreign and Colonial re-exports of motor cars, chassis and parts during the month of October, 1910 and 1911:

	IMPORTS.		EXPORTS.	
	October, 1910 Number.	Value.	October, 1911 Number.	Value.
Cars .....	325	\$547,525	525	\$655,535
Chassis .....	529	660,695	493	627,540
Parts .....	...	837,845	...	956,210
	858	\$2,046,065	1,018	\$2,239,285
	454	\$879,210	630	\$1,309,195
Chassis .....	47	95,165	79	147,405
Parts .....	...	551,855	...	600,780
	501	\$1,526,230	709	\$2,057,380
	93	\$150,535	155	\$279,385
Chassis .....	16	26,410	97	154,490
Parts .....	...	132,820	...	98,150
	109	\$309,765	252	\$532,025

### Compulsory Colors for Public Cabs

Hereafter all public gasoline motor cabs operated in the city of Berlin, Germany, must be "marstallbraun" (a shade of brown) and all public electric cabs must be in "ivory colors." The president of the police board has so decreed, and, it is stated, that the principal reason for this restriction is to be sought in the excessive decoration, in loud colors and extravagant designs with flowing wreaths, luscious bunches of grapes and even bacchanalian symbols, by which the cab companies of the gay German metropolis have heretofore found it expedient to meet the supposedly vulgar taste of the populace. Even those who object to the prescribed monotony on principle are inclined to look upon it as the lesser of two evils.

To KEEP THE OIL FROM CARBONIZING—The Metallurgique company of Montbard-Aulnoye, Paris, has the German patent on a piston in which there is a groove near the top, somewhat larger than the piston ring grooves to be filled with non-conductive material.—From *Der Motorwagen*, November 10.

# Automobile Metallurgy Made Easy

By E. F. LAKE

## Part V

### Impact—Vibration—Hardness Shearing—Bending

(NEXT WEEK—BESSEMER STEEL)

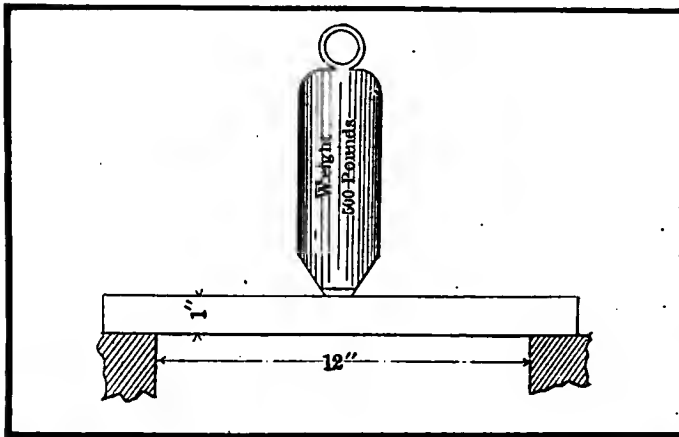

Fig. 1—Impact test



**A**UTOMOBILE materials have been given a number of strength tests, other than those mentioned in the four preceding articles. Nearly all of these tests parallel different kinds of strains and stresses that various parts are submitted to and they are all useful in their way.

All parts of the automobile vibrate continually while the car is in motion. Tests that will show how materials will withstand this vibration are thus beneficial. These tests consist of two kinds, namely, alternating and rotary vibrational tests. The front axle, frame, springs and the other parts that do not revolve are constantly subjected to al-

ternating vibrations in a moving car, while revolving parts, such as the various shafts, are submitted to rotary vibrational strains.

Alternating vibrational tests are usually made by gripping a test bar, 6 inches long, by one end and then moving the other end 1-4 of an inch in opposite directions from its center line. This keeps the bar continually bending back and forth and the number of bends it will stand before breaking is given as the result of this test.

The rotary vibrational test is given by revolving the test bar at the same time that it is moving back and forth out of its center line. The bar tends in both directions with each revolution and the number of revolutions it will stand before breaking is given as the result. Crankshafts, gearset shafts, driving shafts and rear axle shafts all revolve to drive the car while it is traveling over the road, and they are being vibrated at the same time, by the car coming in contact with the road's uneven surface. Hence the rotary vibrational test shows how long different materials will stand this kind of work.

Impact tests are also given steel. These consist of resting the test bar on two supports that are a given distance apart and then dropping a weight on the bar, centrally between these two sup-

ports. This should weigh a given number of pounds and be dropped from a given height. Fig. 1 shows how this test is made. A straight edge laid on the test bar will show the deflection in inches that each blow causes, and thus its resistance to impact. The number of blows before the bar breaks is also recorded. If instead of dropping the weight a pressure were applied to it gradually the transverse strength would be obtained. This test is often used for cast iron and the number of pounds of pressure that is required to break each square inch of the specimen's area is recorded. Pendulum impact tests are made by swinging a weight against the test piece in the same manner that a pendulum swings. The foot-pounds required to break the specimen are given as the result. Impact tests are used very little for automobile parts, but they are well adapted for metals used for some other work. Railroad rails, that continually have heavy weights, in the shape of loaded cars, rolled on them between the supporting ties, are good examples of the need of this test.

Shearing tests are carried on for the purpose of showing how much a metal will stand before it shears off or cuts in two. This test is very applicable to the testing of rivets. The different

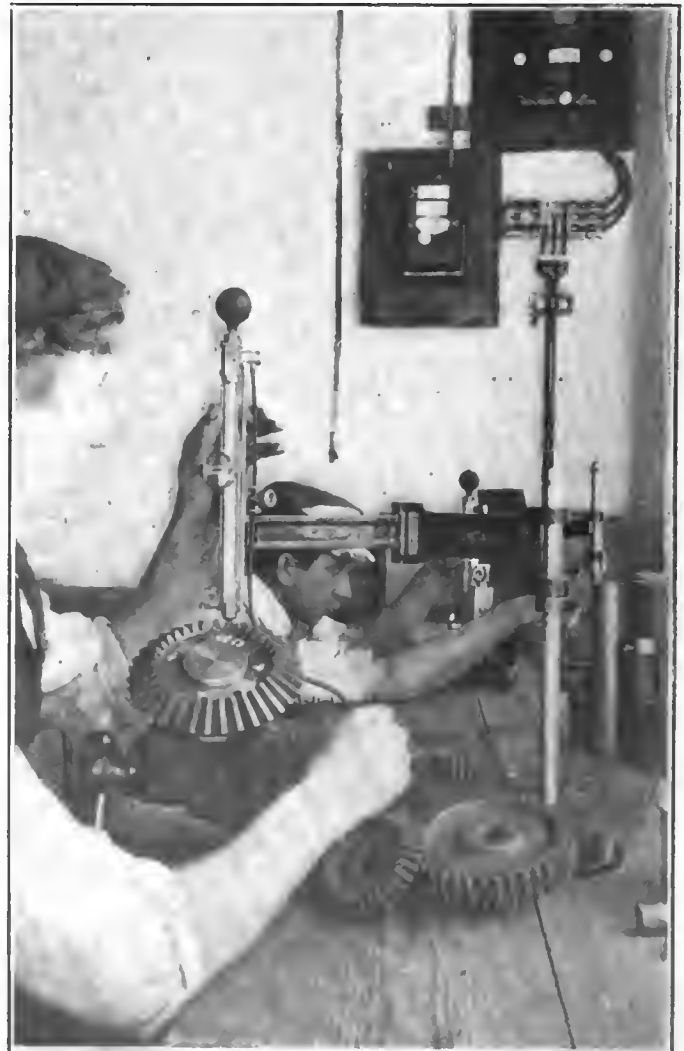

Fig. 2—Testing automobile gear teeth for hardness

pieces that go in an automobile frame have a tendency to slide past each other, from the twists and strains given the car. In thus sliding past each other they have a tendency to shear off the rivets. The leaves of springs do slide back and forth on each other until the center is reached. The central bolt, that holds them together, is liable to be sheared off by this motion continuing past the center. Other parts also have bolts and rivets that are liable to be sheared off. The steels that would be best to withstand this shearing strain could be adapted for use, if samples were first submitted to the shear test. The number of pounds pressure that is required to shear off a given size test bar is given as the result of this test.

Hardness tests are given in several different ways, or rather with several different instruments, each one having an arbitrary scale from which to give the results of the test. The degree of hardness of various metals that enter into an automobile is of importance as this affects all of the mechanical properties, *i. e.*, the tensile strength, elastic limit, contraction, torsion, etc. One hardness-testing instrument drops a ball on the metal and measures the rebound for its result. Such an instrument is shown in Fig. 2, testing the teeth of steel gears in an automobile shop. Another hardness-tester presses a ball into the metal and measures the diameter and depth of the indentation. Such a machine is shown in Fig. 3 and this also records on the dial the number of pounds required to press the ball into the test piece. Another instrument drops a weight on a lead disk placed on the test pieces and measures the amount of its compression.

The degree of hardness of such parts, as gearset gears, is of the greatest importance. These gears must be hard enough to wear well and at the same time tough enough to withstand the strain caused by the clash when they are suddenly thrown into mesh. If too hard the gear teeth will break off and if too soft they will bend out of shape and be useless. All the teeth around the circumference of a gear must be of the same degree of hardness and a testing instrument is very useful for proving this. All moving shafts must likewise have the proper degree of hardness to withstand the frictional wear of the different parts they come in contact with and that move with them. In fact, all of the various metal parts must have a hardness that will best enable them to withstand strains and stresses.

Another test given metals is the bending test, that is, one end is held stationary while the other end is moved enough to bend it around a plug of a given diameter. The number of degrees through which the test piece bends before it is ruptured is given as the result of the bending test. While this may be applicable



Fig. 3—Indentation hardness-tester

to some automobile parts, it is seldom used as some of the other tests, heretofore mentioned, are made to take its place.

A test is also given to metals to show their frictional wear. The thousandth of an inch that wears off from a given area, in a given space of time, is tabulated as the result of this test. Such a test might be useful to show the life of bearing bushings or the parts that operate in them.

## Harking Back a Decade

FROM *The Motor Review*, December 19, 1901:

The United States Circuit Court of Appeals sitting in Boston has affirmed the single-tube tire patent, known as the Tillinghast patent.

In its answer to the suit filed by Richard Siegman, at Trenton, the Electric Storage Battery Co. denies that it has diverted much of the capital stock of the Electric Vehicle Co. into its treasury without adequate compensation. It is explained that 48,000 shares of this stock were used to pay for the controlling interest in the Columbia Automobile Co., which was held by the battery company, but which is now owned by the Electric Vehicle Co.

The Diamond Rubber Co., of Akron, has increased its capital stock to \$1,500,000. The company is now 6 years old, starting with a capitalization of \$50,000.

The new Century car is of the tonneau type. Its wheelbase is 96 inches and there is no machinery above the floor except in the bonnet. The motor is of four cylinders and is geared to 35 miles an hour.

The retail automobile district of Chicago is steadily moving southward on Michigan avenue. Only recently the Winton, Milwaukee and Waverley have determined to move eight blocks south to Fourteenth street. Several other concerns will probably announce similar action in the near future.

F. B. Stearns & Co., of Cleveland, are busy building a racing-touring tonneau of 22-horsepower. A speed of 45 miles an hour is claimed for the new car. The company does not aim to become a large manufacturer, but is planning some additions to its present plant.

The Long Island Automobile Club held its first annual meeting and banquet last week. W. Wallace Grant was elected president and Frank G. Webb treasurer of the organization.

The British government has instituted a prize competition for a tractor for military purposes and an invitation has been extended to American automobile makers to take part. The first prize is \$5,000. The tractor must be able to draw a gross load of 25 tons, 40 miles, at a rate in excess of 3 miles an hour and surmount grades not exceeding 6 per cent.

# Digest of the Leading Foreign Papers

**W**ITH the demand for noiselessness in automobiles and the desire to reduce wear and depreciation to a minimum, designers are turning their attention to suitable devices for testing the correctness of gear teeth curves, either in the shop where the gears are milled or through the facilities of the purchaser. A beginning in this direction, and one apparently susceptible of further development, is described by Moritz Kroll, of Pilsen, Germany, in the form of an apparatus which was first used for instruction purposes at the public trade school in that city. It will be noticed that the grosser inaccuracies due to eccentric mounting of a gear wheel on its shaft or to any curvature of the latter are shown up independently of those due to faults in the tooth curves.

## New Gear-Probing Methods

industrial purposes, Fig. 4 represents the same general type adapted to the testing of bevel gears. Fig. 2 represents diagrams produced by the device under varying conditions.

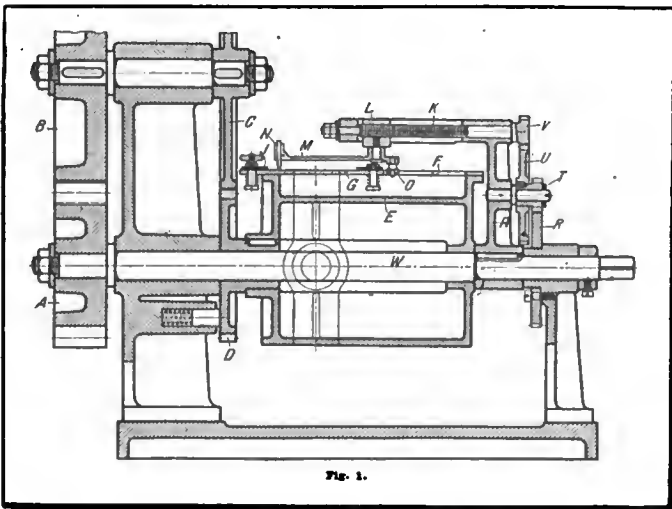

Fig. 1—Apparatus designed for testing and charting gear-wheel inaccuracies

Fig. 1 shows the first apparatus designed, which is applicable only to testing gear wheels of a certain size (15 teeth with 1 inch pitch), but whose recording device is sensitive enough for very minute examinations and enables the tester to locate and measure the inaccuracies. Fig. 3 represents a simplified model applicable to gears of different sizes and believed to be sensitive enough for

Referring to Fig. 1, the spurwheel to be tested, A, is secured upon the end of shaft W and drives through the spurwheels B, C and D the parts E, D and E being free to rotate on shaft W. The gear ratio is 1. If the mesh between A and B is right, E therefore rotates with the same angular velocity as the arm P which is keyed to shaft W and formed with a horizontal branch K. Every error in the mesh of A results, on the other hand, in an advancement or retardation of the arm P with relation to the part E. A sliding piece L in the branch K carries a lever M whose short arm engages a slot in E while the long arm is provided with a pencil point N which marks a diagram on a strip of paper fastened to the part E. In the test, the shaft W is slowly turned one revolution by means of a crank. A pinion T, mounted upon the arm P together with another larger pinion U, is rotated by its engagement with the fixed pinion R and transmits the movement through the small pinion V to a threaded spindle in K whereby the sliding piece L, with the lever M and its pencil point, is shoved forward while at the same time the pencil point is also actuated by any relative movement between P and E.

The curve I in Fig. 2, which is nearly a straight line, was produced with a correctly milled spurwheel A in a certain relative position of the wheels A, B, C and D. Curve I' was produced by merely bringing other teeth on these wheels into engagement, and a defect in the workmanship of the apparatus was thereby discovered. The shafts upon which A, B and C are mounted had first been turned down, as is generally done, as far as to the collar and had then been reversed in the lathe to turn the reduced ends, but by this operation the latter had become very slightly eccentric, this accounting for the bend in the diagram. By placing the two shafts so that the eccentricity of one neutralized that of the other the diagram I' was obtained. Diagram II was produced from a wheel whose pitch circle was about one-half millimeter too small, while the depth of the teeth was correct for the right diameter.

Diagram III was obtained from a wheel which had been milled with a cutter intended for a wheel with 25 teeth, and diagram IV from a wheel in which three spaces had been specially milled

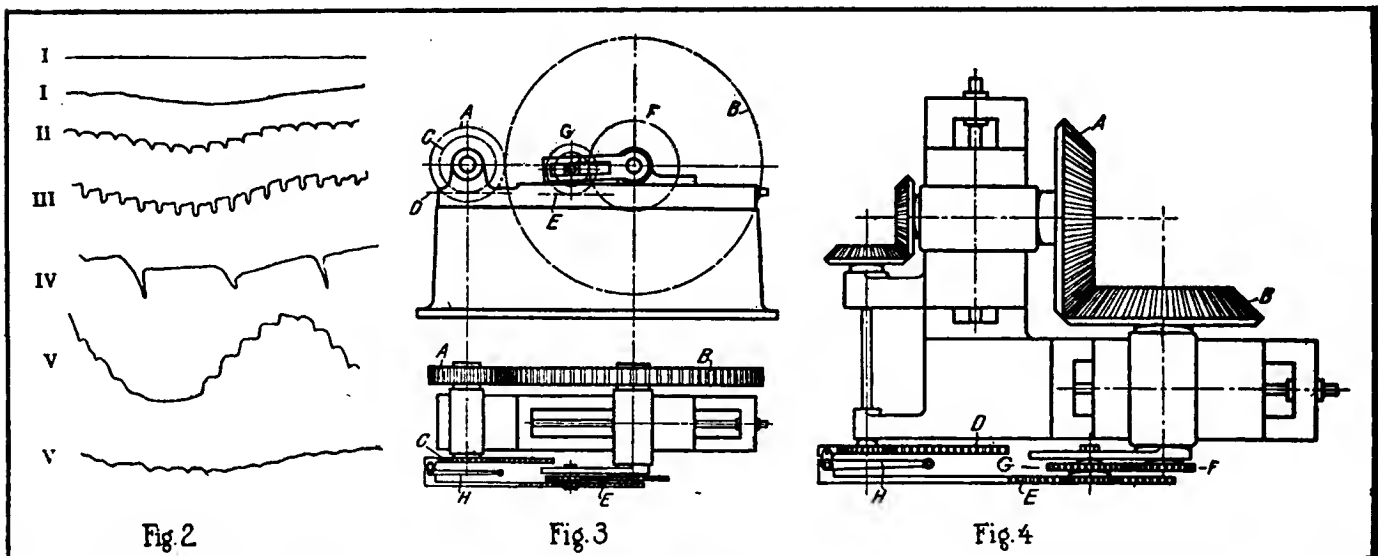

Fig. 2—Diagrams of various gear defects Fig. 3—Sketch of universal spur wheel testing machine, side and plan views. Fig. 4—Sketch of bevel gear and rotary machine, plan view



too deep, so that they were about one-half millimeter broader than the correct ones.

Diagrams V and V' show how strongly an eccentric mounting of a spurwheel on its shaft affects the mesh. The bore of a correct wheel was filed out on one side and wedged eccentrically upon its shaft. The double curvature of the diagram comes from the mesh being too close on one side of the wheel and too open on the other, while the small waves indicate the inaccuracies in the contact of the teeth produced by the misalignment. But when the wedge was inserted on the other side of the shaft diagram V was produced.

In an apparatus adapted for trying spurwheels of varying sizes, as shown diagrammatically in Fig. 3, one of the wheels to be tested, A, is mounted in bearings in the base of the apparatus; the other wheel, B, on a sliding carriage. A is turned a full revolution in the test, and the pinion C, which is mounted on the same shaft with A, thereby pushes a toothed rack D a certain distance, equal to the circumference of C. At the same time another rack E is pushed an equal distance in the same direction through a system of exchangeable pinions F and G, working from the shaft of B. Every fault in the mesh of A with B results in a relative advancement or retardation of the two racks. Rack E carries a bell lever H whose short arm is journaled in rack D, while the long arm carries a pencil point which writes the diagram on a fixed strip of paper.

To get correct readings from an apparatus of this kind it is the supposition that the exchangeable gear wheels, F and G, as well as the racks are properly milled, but if the pitch of these auxiliaries is made quite small, say, 1 to 2 millimeters, even the smallest of them will have a large number of teeth and their faults will show in the diagram curve as very low and short irregularities sharply distinguished from the higher and longer waves which will be produced by errors in the cutting of wheels A and B. The influence of backlash in all the wheels can be counteracted by suitable one-sided loading of the testing movement. The apparatus for testing bevel gears, as sketched in Fig. 4, differs only in having the two wheels A and B mounted on carriages of which one is slidable at right angles in relation to the other.—From *Werkstattstechnik*, November.

**MUD SPLASHING**—By a recent court decision in Germany two pedestrians were awarded damages from the driver (owner) of an automobile because the latter, though he had not been driving fast, was held not to have observed due caution to avoid splashing mud upon the two pedestrians on the sidewalk, and the case is exciting much comment in both automobile and anti-automobile circles. In France the same question has been taken up peaceably by the Automobile Club of Seine and Oise which has organized a contest, beginning February 5 next, for makers of anti-splash devices to be attached to or near the hubs of wheels on rainy and muddy days, and which must "not interfere with the esthetic appearance of the vehicles." The regulations for the contest provide that vehicles shall be driven through the mud at 25 to 40 kilometers per hour with the device attached, and as often as the jury of awards may decide to be necessary. The bespattering of the vehicle itself, especially its under surface between the wheels, will also be considered, as well as the time required for attaching the device.

**MEASURING EFFICIENCY OF GEARS**—Mr. Rikli describes in the *Zeitschrift des Vereines Deutscher Ingenieure* for August 26 an apparatus designed for testing gears under full load without great expenditure of motor power. The device recalls that used by Hopkinson for testing electric motors by grouping them pairwise in opposition. It is shown in Fig. 5. A motor M drives through a clutch K a shaft  $W_1$  on which are keyed two pinions  $r_1$  and  $r_2$ . These are in mesh with two gear wheels  $R_1$  and  $R_2$ , of which  $R_1$  is keyed to shaft  $W_2$ , while the other is idle on this shaft and draws with it, by means of a dog, a sleeve with two flange plates T. On the end of shaft  $W_2$  there is keyed a plate  $S_1$  which drives plate  $S_2$  as in one with it, because an irreversible worm, journaled

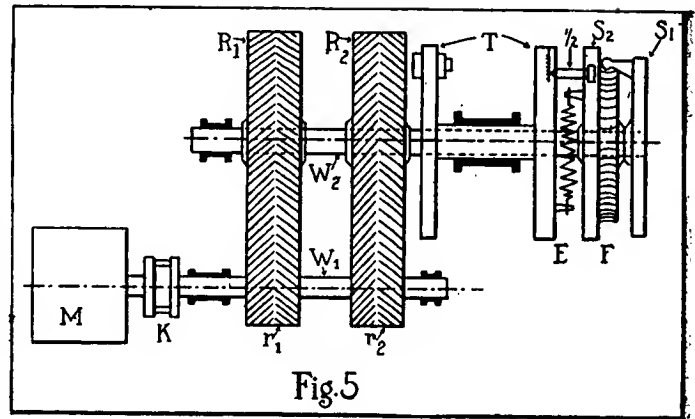

Fig. 5—Rikli machine for testing efficiency of gears

in  $S_1$ , is in mesh with the helical gear wheel F secured to  $S_2$ , and this plate  $S_2$  is attached to the adjacent plate of sleeve T by four springs E, which may be stretched to a desired tension by means of the worm.

The tension of the springs E determines the pressure sustained between the teeth of gear wheels  $R_1$ ,  $R_2$  and those of pinions  $r_1$ ,  $r_2$ , and consequently the effort transmitted between these pinions, of which one may be considered the driver and the other the driven. By varying this pressure and the speed of rotation of the machine, it is therefore possible to modify at will the effective work of these pinions and to determine the efficiency of the gear, provided the power required for actuating the two gear wheels, which power is entirely utilized to overcome the friction in the gears and in the bearings, is known. The author tells of a series of tests made with this apparatus which admits of an accuracy which it has heretofore been found impossible to reach, owing to the high efficiency attained in gears and the multiplicity of the losses to be measured.—From *Le Génie Civil*, November 4.

**FLAME-WELDING AND CUTTING**—The oxy-acetylene flame gives a heat of 3,600 degrees Centigrade, the oxy-hydrogen flame 1,900 degrees and the coal gas or gasoline vapor flame fed with oxygen a heat of 1,600 degrees. Those who contemplate the purchase of an oxy-acetylene apparatus for autogenous welding or metal cutting should therefore not permit themselves to be influenced if it is represented to them that the same work may be done with an apparatus operating with hydrogen, gasoline vapor or illuminating gas as with one of the latest improved models of oxy-acetylene plants. A description of suitable acetylene generators and of the most recent British improvements in burners is offered in *Der Praktische Maschinen-Konstrukteur* for October 12.

**PERMANENT DEVELOPER**—Tourists who prefer to develop their own plates or films will be interested to know that a bath composed of 10 grammes of paraphenylene-diamine, 30 grammes of bisulfide of soda at 35 degrees, 3 grammes of bromate of potassium and 40 cubic centimeters of caustic soda (sodium hydroxide) at 30 degrees, if bottled and protected against atmospheric influence, will keep almost indefinitely. The author has developed plates with a bath which had been prepared for more than one year.—J. Desalme in *Bul. Soc. Francaise de Photographie*, reported in *Revue de Chimie Industrielle*, November.

ACCORDING to the *Daily Consular and Trade Reports*, the use of motor mail vans is still being extended in England, and over 100 services or sets of services are being performed by this means. Failures and serious delays are now of comparatively rare occurrence under normal conditions, and the greater speed of motor as compared with horse traction is of considerable advantage to the mail service.

# Letters Answered and Discussed

## Trouble with Patches

EDITOR THE AUTOMOBILE:

[2,958]—I am having considerable trouble in getting patches to stick to the inner tube. I am sure that the cement I am using is of the best quality, yet I do not seem to be able to get results. I would greatly appreciate it if you would give me a few tips on how to manipulate the gum. TYRO.

Clarkesville, Tenn.

The probable cause of your failure in applying the patches is that you do not have the rubber sufficiently clean. This is a point that is very frequently overlooked by amateurs. A piece of sandpaper should be used as in Fig. 1. When assiduously

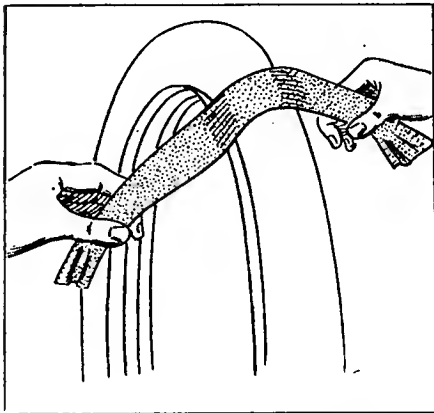

Fig. 1—Method of cleaning a tire with sandpaper

applied this will remove any excess dirt from the rubber and greatly assist the work of repairing. If the patch is not applied until the rubber cement is nearly dry it will often hold better.

## Has Crankcase Explosions

EDITOR THE AUTOMOBILE:

[2,959]—Being a constant reader of your publication I take the liberty to ask for a little information concerning the oiling system of my car.

This motor has a filler on the right side of the crankcase and a large breather on the left. Now very frequently there is a light explosion in the crankcase, which one would judge at first to be crankcase compression, but on account of so much smoke and the odor of same I now think this an explosion of gas. About one-half the time this explosion will pass out through the breather, the other half through the filler, taking with it about one-half pint of oil. I put the blame on the oil at first, but have

*The Editor invites subscribers to communicate their automobile troubles and personal experiences, stating them clearly on one side of the paper. If the nature of the case permits, send a sketch, even if it be rough, in order to assist to a clearer understanding. Each communication will receive attention in the order of its receipt, if the writer's signature and address accompany it as an evidence of good faith. If the writer objects to the publication of his name, he may add a nom de plume.*

tried the very best grades of oil on the market and it is the same old story. This motor has a constant level splash system and the overflows from the crankcase to the oil pan below are open, so, of course, the amount of oil in the pan, unless it was too full, would make no difference. The breather is open for one time it will relieve the pressure and again it won't. The condition of the road makes no difference, for this explosion occurs while going fast or slow, on level ground or up and down hill.

I will appreciate any information THE AUTOMOBILE can give me, and would like to hear from some of the readers who have had similar troubles. OWEN.

Minden, La.

The gas probably leaks past the piston rings on the compression stroke and accumulates in the crankcase where it is finally fired. This crankcase explosion will only occur in case the piston rings are so badly worn that the flame from the burning charge will flash past the bottom of the piston and ignite the inflammable gases which have accumulated within the crankcase after a series of compression strokes have allowed a sufficient amount of gas to leak down into the crankcase. There is also a probability that the breather pipe has not been kept as free as it should be on account of the screen having become choked with accumulated dirt. By removing this dirt and renewing the piston rings. There is also a possibility that there is a blow-hole in the top of the piston casting which allows the gas to penetrate the crankcase, or a very slight possibility that the cylinders are scored deeply. A good method of ascertaining if the cause of the trouble comes from any of these sources is to test the motors for compression.

## Renewing Clutch Leather

EDITOR THE AUTOMOBILE:

[2,960]—I have a car on which the clutch leather facing is worn and which I desire to renew. Would you kindly tell me the kind of leather to use and the method of

applying the same to the clutch member? Mechanicsburg, Ohio. E. R. S.

When removing the rivets from the old leather care should be taken not to tear the leather so that it may be used as a template in cutting the new leather. This should be cut from the thickest part of the hide. The old facing is laid over the new and the position of the rivet holes located thereon by marking through the old holes with a pencil. The rivet holes are then cut and countersunk so that the rivets will be well below the surface of the leather. The rough side is turned out. The fitting has to be very carefully done and a superior job is made if it is trued up in a lathe. It should then be soaked in castor oil and will be found to apply itself to the female member of the clutch.

## Wants Valve Information

EDITOR THE AUTOMOBILE:

[2,961]—I have several times read that there should be no lost motion in the valve action. All the advice I received through the reading of various books and publications led to my investigating the valve rods on my car and after a large amount of trouble I located some clearance space between the tappet and push rods. I was just about to adjust the rods so that there would not even be this small amount of space when I was told by a man whom I know to be somewhat of an authority on the subject that I should leave the clearance as it was since the rods expanded when the motor was running owing to the heat. Now

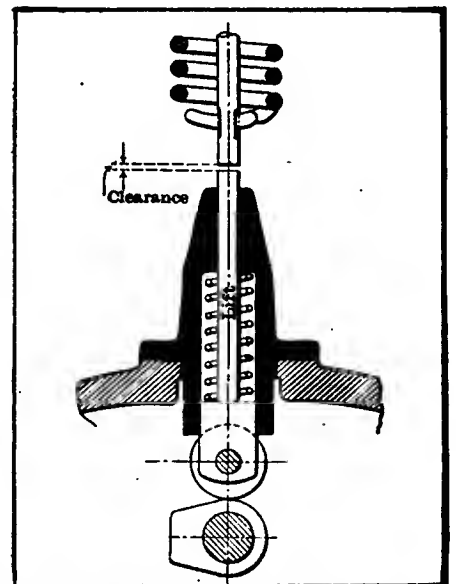

Fig. 2—Valve tappet having no provision for adjustment of clearance

I am all at sea on the subject and wish that you would clear up the mystery for me.

M. BEPPO.

Allentown, Pa.

The mystery is readily explained since both parties gave you the correct advice. Since the clearance which should be left at the point shown in Fig. 2 will close up after the engine has become warm, there will be no lost motion at this point. This will be the case whether there is an adjusting device on the stem or not. On all cars built within the last few years, however, this device will be found. The adjusting device is shown in Fig. 3 and should be tightened up so that there will be just sufficient clearance at the point designated, that a visiting card may be inserted between the two members of the rod.

### Belittles New Motor

Editor THE AUTOMOBILE:

[2,962]—In THE AUTOMOBILE of November 12, appeared an article entitled Tesla's New Mechanical Principle. To anyone interested in the description of the new motor, which is to give such high thermal efficiency, I should like to suggest the reading of an article designated Bladeless Turbines printed in *Engineering*, London, dated November 10.

The article deals with Tesla's motor from an engineering standpoint and, in my opinion, shows the fallacy of the principle used.

M. H. W.

Chicago, Ill.

The article referred to contains a criticism of new experiences on a basis of old-approved formulæ, proving the impossibility of constructing a motor as the one in question.

We remember a certain Robert Fulton, who steamed up the Hudson, even while his act of doing so was pronounced an impossibility by his fellow-citizens, as well

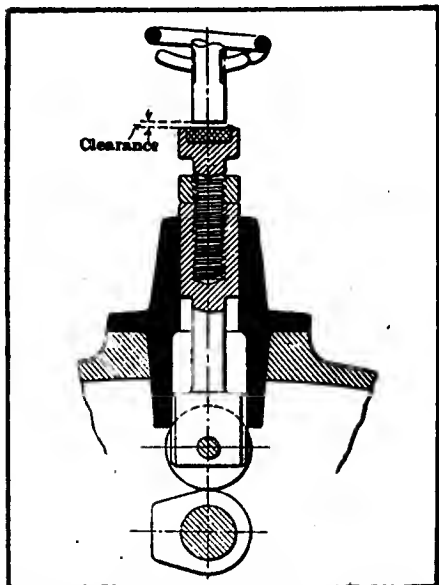

Fig. 3—Tappet of better design, showing adjusting device

as the example of one Knight, whose construction was scoffed at and considered impossible at the very moment it was propelling an automobile through the streets of Chicago.

These examples, with a score of others in history, show that formulæ are nothing eternal and unalterable, but that they hold good quite as long as they are applied to the conditions they were made for, and that, when new experiences come up, it is the formulæ that have to be adapted to facts and not *vice versa*.

### Interested in Self-Starters

Editor THE AUTOMOBILE:

[2,963]—I notice some self-starters that are being shown in the journals which obtain a sufficient charge of gas from the acetylene tank by the suction of the engine on the opening of the gas line after cutting out the ignition, which it is claimed will start the motor after standing several hours by merely turning on the switch.

Will you kindly explain in the letter columns of THE AUTOMOBILE how this is accomplished and why the acetylene will do this when the gas from the carbureter will not. Do you think that starting the motor in this manner would strain it in any way?

Newcastle, Pa.

J. H.

There are no self-starters using acetylene which rely on the suction of the motor to draw in a charge and then start on the spark in the manner you describe. The acetylene self-starters either allow the gas to flow into the cylinders under pressure or the gas is forced in by means of a small hand pump. Self-starters are not made with the idea of starting the motor after it has been at rest a few hours, but are intended for the purpose of starting at any time.

### Front Tires Wear

Editor THE AUTOMOBILE:

[2,965]—One of the strange features about my tire troubles, of which I feel that I have had more than my share, is the fact that the front tires wear out much more rapidly than do those attached to the driving wheels of the car. I do not know how to account for it exactly as the tires on the front wheels seem to be worn on the outside more than on the inside. I would greatly appreciate it if you could tell me through the columns of THE AUTOMOBILE what the causes of this trouble could be.

Cornwall, N. Y. EDWARD BRONSVELD.

It is very evident that the front wheels are out of alignment. This may be readily determined by the method shown in Fig. 4. A tape measure is used to find the distance between the two inner edges of the rims of the front wheels. The wheels are then turned to different positions and the distance measured at the same height above the ground in every case. A rather

ingenious method, but one which is not so accurate, is to apply whitewash to the tires and spin them to see if the lines of whitewash thrown off are parallel.

### Loss of Compression

Editor THE AUTOMOBILE:

[2,964]—I have a car in which the motor does not develop the power it should, due to one of the cylinders losing compression past the piston rings into the crankcase. I put on some new rings but it did not seem to do any good, when I put on the new rings I noticed parts of the rings were worn bright and other parts had dark places on them. Will you please tell me the best and proper way to overcome this leakage.

F. A. NELSON.

Rupert, Idaho.

The correct method to use in such a case is to have the cylinders rebored. They are evidently worn irregularly if the piston rings are not bright on all sides and you are losing compression. This will have to be done by a reliable concern or

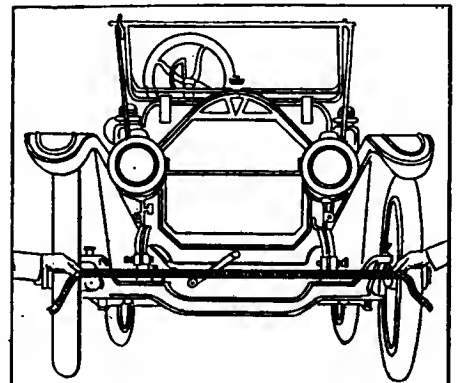

Fig. 4—Showing method of aligning front wheels

the motor will be hopelessly ruined should the work be carelessly done. The factory would be the best place if it is not too far away from you.

### A Worthy Cause

Editor THE AUTOMOBILE:

[2,966]—Will you kindly allow a little space in the pages of THE AUTOMOBILE for the following few lines: I am a teacher of foreign languages in the Benjamin school, 144 Riverside Drive, New York City, and in my spare time I am endeavoring to do philanthropic work. The Cherry Tree Home for Children in Spring Valley, N. Y., needs very badly a vehicle that would serve to carry the children.

The manager of the school, Major Erberich, asked me to see what could be done for the purpose. They are willing to give a small sum for it, but we thought that at this season of the year there might be someone who would donate a new, or even an out-of-date automobile for such a worthy cause.

New York City.

ANNA DIEHL.

# Little Bits of Motor Wisdom

## Pertinent Pointers of Interest to Repairman and Driver

**S**OLDERING FOR AMATEURS— Hundreds of burr fingers and other proofs of an active interest in the art of soldering on the part of tyros go to prove that this apparently simple operation has its difficulties and puzzling features. Solder is the metallic parallel of the glue used in connection with wood-work and other work in which this fluid plays the part of a connecting agent. To define solder is impossible, as there are

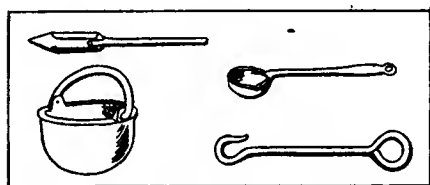

Fig. 1—Tools used in soldering

so many compounds which bear that name that a lengthy list would be required to mention all the compositions which are used for the purpose of making metallic joints.

Common features in all solders is that they have, as a rule, lower melting points than the metals which they connect and they are weaker than most metals, so that a soldered joint is never made where it is required that the joint be particularly strong. If strength is required, the joints are either brazed or welded. These, of course, are more costly operations than soldering, but are of much greater strength. In many of the welding operations the joint is stronger after it is made than the metal itself.

The correct solder to use varies with each metal so that it is impossible to describe soldering in general, although the necessary steps which are common to all work of this nature may be mentioned by way, perhaps, of explaining the cause of a possible failure where the correct solder has been used for a certain piece of work, and yet where that work has proved other than a success. The first point to be observed is that the metal must be scrupulously clean. The metals are then heated to a point where they will unite with the solder in making the joint and covered with a flux so that the surfaces will be maintained absolutely clean. The solder is then applied with a soldering bit and the metal joined together. The joint is then cleaned and finished and allowed to thoroughly cool. The flux may be applied to the metal before it is heated if it is of borax or resin solution, but if it is a liquid

it is better to heat the metal and then apply the flux.

The cleaning is accomplished by means of a rag which will remove all grease and leave the metal about to be joined perfectly dry and free from grease. A scraper and file are then called into requisition and the parts to be joined are made bright. The effect of the flux which is applied is to eat away the film of oxide which accumulates on the surface of the metal.

The solder, which is in general a lead and tin combination of various proportions, is then melted on the hot metal by means of a gasoline torch, Fig. 4 or in the case of smaller work this is often done by means of a candle. Where a soldering bit is used, this is heated to a low red heat and then pressed against the solder, causing it to run over the surface of the metal. The metals must not be too hot as they will then tend to oxidize in spite of the flux or will make the solder too fluid. Soft solder, which is used in the majority of small jobs, consists of 1 part lead to 2 parts tin. The flux used will vary with the metal to be joined. Zinc chloride is used with lead, zinc, copper, etc. Aluminum should be welded.

**TEMPERING OF TOOLS**—The subject of the hardening of metals of many different sorts has been of interest to humanity as far back as we have any record in history. The old art of tempering certain forms of metal has been lost to some extent although marked improvements have been made in this direction in the past few decades.

All those who do any extended work with tools should know how to temper them, as it will be found that the necessity for so doing will often occur. This is especially so in the case of a garage where the work done is in most cases upon hard metals and with tools which require frequent grinding. Skill in the art of tempering can only result from experience, as personal judgment is the most important factor in connection with the work. Tempering processes require a rather more complicated apparatus than that usually made use of in the ordinary operations of forging. Care has to be taken in the tempering process that unequal cooling or heating shall not occur; for if it should, the internal strains in the metal caused by the unequal expansion or contraction of different parts of the same piece of metal will cause a break in the metal.

There is no satisfactory explanation as to the reason that the metal assumes different shades of color as it reaches different degrees of hardness nor why a sudden change of temperature should harden the metal. It is only known to be a fact and although several theories have been advanced which seemed to fit a large number of the phenomena, there are other points which still remain unexplained. It is for this reason that absolute directions as to how to go about tempering a certain piece of metal cannot be given. Experimenting is the only possible way to obtain definite knowledge, although a few of the salient points may be pointed out which will act as a guide to those who are interested in this form of work.

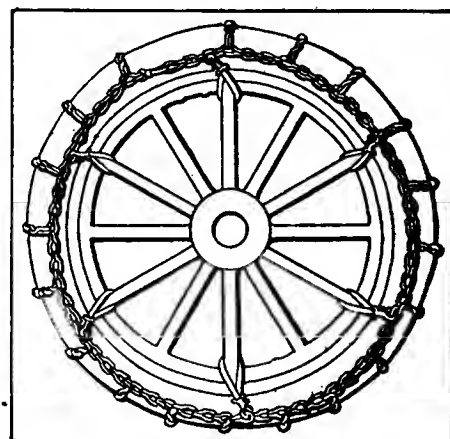

Fig. 2—Wrong way to apply chains

The first point to be observed in the cooling process is that the bath should be so arranged that there is no irregular cooling or, what is the same thing, irregular contraction, for such severe stresses are set up within the metal if this takes place that it will generally be very apt to become distorted or broken. Most tools are of wedge-like formation, so that care must be taken that when they are immersed the thick end of the wedge is always placed in the bath first. This is particularly true of tools which are in the nature of wide chisels. A wide chisel is very apt to crack if placed in the cooling bath with the cutting edge first, and another point to remember is that the temper given to a tool when the cutting edge is the first to go into the bath is irregular, the metal gradually diminishing in hardness from the point or edge.

It is almost useless for any novice in the art of tempering to pick up a book on the subject and read the explicit directions

which are often given regarding the color which the metal is allowed to attain before it is plunged into the cooling bath. This is a thing which will have to be seen more than once before the tyro in the art will be able to accurately gauge the delicate shades which fade into one another so smoothly and withal so rapidly. When steel which has been raised to a red heat is plunged into cold water it becomes excessively hard and brittle; the more suddenly the heat is abstracted from the metal the harder and more brittle will it become; but in order that it shall have qualifications necessary to be of any use it must be tough. This toughness is given to the steel by a process of tempering. In order to produce steel which will have this quality to a necessary degree the metal is reheated and when the film of oxidation, which changes color with the variations in temperature, reaches the desired shade, the metal is cooled quickly and regularly by immersion in the bath most suited to the requirements of the temperature at which the part is to be chilled.

In ordinary mechanics' tools the tempering process is carried on by first heat-

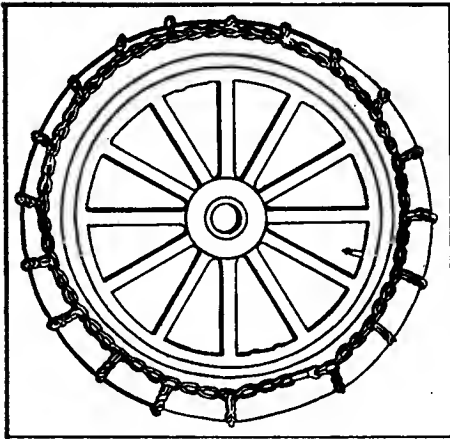

Fig. 3—Right way to apply chains

ing the metal to a bright red heat whereupon it is plunged rapidly into the water and then withdrawn. A scale will form on the outside of the metal which is immediately scraped off. As the surface only has been cooled by the short immersion which has been given the tool the interior of the metal will still be at practically the same temperature that it was before the tool was plunged into the bath. Owing to the conductivity of the metal the outer crust of the metal will be gradually reheated by the interior and will acquire various tints which correspond to different temperatures. When the shade is reached that has been determined by experience to be the best for the work in hand, the metal is plunged into the bath and rapidly stirred about so that the cooling will be equal throughout the entire piece.

In small tools, which are so thin that the interior is cooled at the same time as the exterior when plunged into the water, a hot plate is brought into requisition for the

purpose of reheating the metal to the required shade.

There are several ways of heating steel parts to bring them to the required temperature for quenching, as the first plunge into the bath is called. They may be heated over an open fire, heated upon a hot plate, on a pan over a charcoal fire or, in the case of small articles, by placing them in oil which has been raised to the correct temperature or in a molten alloy. The principal thing to remember, however, regardless of how the piece is heated, is that before quenching the temperature of the metal should not be excessive. In the better grades of steel a low cherry red will suffice. A gauge as to the hardness of the metal after it is dipped may be readily obtained by trying it with a file. On the other hand, if the steel is not properly hardened it cannot be satisfactorily tempered. Cold chisels and iron-cutting tools are chilled at a temperature of about 490 degrees Fahrenheit, which corresponds to a very dark straw yellow color.

**NON-SKID CHAINS TEAR TIRES**—It may be well said that non-skid tires are to a great degree more of a necessary evil than a delight to those who are compelled to use them. It should always be remembered that when these tire chains are fitted they should not be confined so that the links in the chain are continually over the same spot but they should be allowed to creep along the surface of the tire. If any one of the links in the chain is continually pressed against the same spot in the casing of the tire it will gradually imprint itself into the rubber.

It is very easy to see what the effect would be if the chain had sunk into the rubber for any distance and the car were to swerve suddenly. A tearing effect would be produced which would be very apt to result disastrously to the casing eventually. Chains should never be fastened to the spokes of the wheel, as is often done. This is the surest way to invite rapid wear.

Another point to remember in the application of chains is that they are not intended for use on city streets where the hard pavements will greatly augment the wear that the chains are inclined to cause. The chains find their best field of use in the soft mud of the country roads, where they are admittedly a necessity and where they are not backed up by a hard under surface which presses them into the tire casings. The greatest injury will result to tires when they are used on asphalt or similar roads.

**UNDERINFLATION A CAUSE OF TROUBLE**—The evils of underinflation have been dwelt upon to such an extent in late years that there are few who have not heard a detailed account of the results of this form of neglect. Still, it might not be amiss to point out some of the more serious results

of underinflation which have been the experience of those who have had the opportunity to see these results demonstrated in a practical way.

After a period of running while soft the tire will start to take on a baggy and out-of-shape appearance which will first demonstrate itself in the looseness of the tread. If the abuse is continued the looseness will become aggravated until it finally reaches such an advanced stage that the tire casing will be found, upon examination, to be distorted in a series of parallel ridges which run across the face of the tread. This wavy condition cannot be cured when it is once started, and a tire that has attained this shape is well on its way toward the scrap heap.

This particular case of tire trouble is one which strongly brings forth the old adage concerning the ounce of prevention, as a few extra strokes on the tire pump are all that is necessary to safely avoid any injury of this nature. The small cost of a tire gauge is well repaid by the good it can do in this direction, for by noting the pressure and following the directions of a reliable inflation table it will be found that this trouble is never experienced. Besides the ill effects on tires, the rims are damaged by underinflation, as whenever the car passes over even a slight ridge, the rims are apt to be cut by impact with stones or ruts.

When the car is turning a corner and the tires are not sufficiently inflated the bead will lift from the rim and pinch the tube between the bead and the rim. The result will be that the tube is cut and a blow-out occurs. Before attempting to replace the outer bead in the rim-casing the tube should be slightly inflated and the hand passed inside the casing to make sure that the tube is not twisted or caught under the security-bolts as this would also cut the tube.

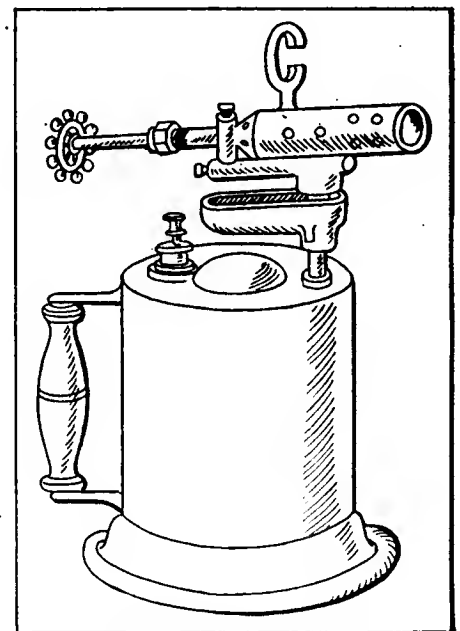

Fig. 4—Gasoline torch for soldering



# My Ideal 1912 Automobile

## Readers' Conceptions of What Next Year's Car Should Be

### Features Accessibility

EDITOR THE AUTOMOBILE:

My ideal car for 1912 should be built as follows: The motor should be a T-head type with long stroke. There should be six cylinders cast in pairs with dimensions of 4 1-4 inches by 5 1-2 inches, and the maximum speed should be 1,800 revolutions per minute. The 2 1-2-inch valves should be covered with easily-removable protectors. The crankshaft should have five ball-bearings and it should be offset 1-2 inch. The pistons should be removable from below.

The motor, clutch and transmission should be built as a unit and suspended on three points by the top half of the crankcase which should be made of bronze. A Bosch magneto should be on the left or exhaust side of the motor, and a hard rubber bar should be used to simplify the wiring for both magneto and battery plugs which should be over the intake valves. A large centrifugal pump should be placed on the right side of the motor with large connections leading to the cylinders and the honeycomb radiator. The radiator cooling should be augmented by a gear-driven fan placed slightly toward the exhaust side of the motor. There should be an automatic oiling system, and the oil should be pumped through the hollow crankshaft and up the connecting rods to the wristpins, with a reservoir in the crankcase allowing splash for the camshaft and the main crankshaft bearings. Special arrangements should be made for cleaning, replenishing and taking care of the system.

The clutch should be of the multiple disc type, having 61 plates running in oil, and with automatic adjustment. The plates should be made of bronze and steel. A four-speed transmission with direct drive on the fourth speed has proven satisfactory. Special attention should be paid to the accessibility for the examination of the clutch and transmission. Straight-line drive should be used when the car is loaded, and there should be two universal joints inclosed in dust-proof aluminum casings. The differential should be floating, the case being made of pressed steel and strongly trussed. Adjustable radius rods and a torsion tube should be used to strengthen the construction. A trussed channel-steel, drop-forged frame should be employed, together with an I-beam axle in front having a tie-rod behind and above it. Annular bearings should be used in all wheels, and also in the differential, transmission, clutch and clutch-thrust. The front springs should be long and wide, of the semi-elliptic type, while the rear springs should be three-quarter elliptic. Shock absorbers should be used on all springs. Large expanding and contracting brakes with equalizers should be put on the rear hubs. They should be 18 inches in diameter by 3 inches wide. Steering should be irreversible with simple adjustment, and should be accessible for oiling and inspection. Spark and throttle levers should be located on a 20-inch corrugated, hard-rubber steering wheel. An accelerator and a common control for the other levers should be included. The wheelbase should be 135 inches, the tread 56 inches, the clearance 11 3-4 inches and the body a four- or five-passenger torpedo.

The equipment should be as follows: Booth demountable rims, size 36 inches by 4 1-2 inches, with two extras carried in the rear, a 30-gallon gasoline tank, also carried in the rear, with pressure gauge carried on the dash, a 2-gallon extra oil tank, top side curtains, banker windshield of the rain-vision type,

*Readers continue to demonstrate their interest in the ideal car and the specifications which are submitted show a wide range of taste and requirements. In view of the interest shown the Editor continues to extend the invitation to all who entertain ideas on this absorbing topic to submit their opinions for publication. The description should be legibly written on one side of the paper and signed by the sender, although if it is so desired the name will not be published.*

nickel and black trimmings, Gray and Davis electric lights, Klaxon horn, Warner speedometer and clock, gasoline gauge, tire irons, four-cylinder tire pump, complete set of tires, tire tools, robe rail, Disco self-starter and a gradometer.

Too great emphasis cannot be laid on accessibility. Every nut and bolt should be removable with an ordinary wrench.

This car should weigh about 3,000 pounds when filled with gas, oil and

water. The cost should not be over \$3,000.

Greeley, Colorado.

NELSON REYNOLDS.

### Emergency Foot Brake

EDITOR THE AUTOMOBILE:

This is my ideal car for 1912. The motor should have four cylinders and should be of the monoblock type. The size of the cylinders should be 3 1-2 inches by 7 1-2 inches, with which dimensions it should develop between 20 and 30 horsepower. This would be plenty for any part of the country. The Bosch high-tension, dual magneto system should be used, also the force-feed lubricating system.

The car should be equipped with a cone clutch, leather faced, which is far superior to any other clutch. The transmission should be of the selective type with four speeds forward and reverse. The gear ratio on fourth speed should be one and one-half or two to one. The car should have shaft drive, and the front springs should be semi-elliptic, 50 inches long, while the back springs should be three-quarter elliptic.

The length of the wheelbase should be specified as 130 inches and both the front and rear tires should be 36 inches by 4 inches. The rear axle should be of the full-floating type, and the front one should be a B. & L. Castor, which in my opinion is safer and easier on the driver than the old kind. The steering should be done through an 18-inch steering wheel with spark and throttle levers on the top.

For the control, there should be two pedals and one gear-change lever. The left pedal should operate the clutch and service brake, one-third downward movement releasing the clutch and further movement applying the service brake. The right pedal should operate the emergency brake.

An electric generator, such as is used on the Cadillac, should be used for lighting and starting the motor. The rest of the equipment should be standard. The body for the car should be of the fore-door type.

This car could be manufactured for \$1,250 or \$1,500, according to the type of body wanted.

Saylorsburg, Pa.

ROBERT L. SNYDER.

### Wants No Muffler Cut-Out

EDITOR THE AUTOMOBILE:

I think it might be a pertinent suggestion in connection with the discussion of car improvements now going on in the columns of THE AUTOBILE that the muffler cut-out should be omitted, because when it is fitted, it is sure to be used and this goes a long way toward making the car a nuisance on account of the abuse to which this attachment is often put by the thoughtless.

P. CARR.

Schenectady, N. Y.

# New Ideas Sketched in Berlin

## Fancy Seats for German Cars—Other Novelties Noted There

At the recent automobile exhibition in Berlin the Wilken-  
ing floating seat (*Schwebesitz*) attracted considerable  
attention. As compared with the seats usually fitted to  
automobiles it is supposed to represent a refinement in the way of  
comfort and at the same time a saving in weight and space, and  
perhaps in economy. It is an elaboration of a style of easy chair  
which years ago was much in use in Europe, generally in the  
form of a rocker, but its comfort in the cruder form was not  
considered unsurpassed. The illustration (Fig. 1) shows the pres-  
ent construction (German patent 221,922). The two triple leaf  
springs A on each side of a seat are joined at the top by a trans-  
verse bolt C around which the roller sleeve D turns on ball-bear-  
ings. At their front ends the springs carry, on flattened and  
slotted portions B, the cross board E, whose position may be ad-  
justed about 31-2 inches by  
means of thumbscrews F and  
to which are secured the series  
of springs G. These are uphol-  
stered, and the woven material  
H is secured around them and  
passed slack over the roller  
D, the edge being stiffened  
with a rod I to the ends of  
which are attached eyelets K  
hooked to coiled springs L.  
The lower ends of these  
springs are attached to the  
scrolled upper ends of the base  
leaf in each of the springs A,  
and their strength may be  
chosen to suit the weight of  
the person occupying the seat,  
particularly on the occasion of  
long-continued journeying. To  
obtain the maximum of com-  
fort the material H should be  
hung very slack and the hol-  
low formed should be filled  
with an upholstered cushion  
M. A thin horsehair cushion  
for the back N is also ad-  
visable.

When to be used where it

is desirable to save space if a seat is not engaged, the springs A  
are made with a joint which admits of the seat being folded up.  
For the same purpose the usual manner of mounting the seat is  
by means of tubular rails on which the seat may be slid forward  
or backward, as indicated in the illustration. The most important  
space economy is secured through the fact that the back of the  
seat has no appreciable thickness, so that the knees of a pas-  
senger in a rear seat, in the case of a car with six or seven seats,  
can extend forward between the springs A of the seat in front  
of him.—From *Zeitschrift des Mitteleuropaischen Motorwagen  
Vereins*.

In the 40-60-horsepower Renault car shown at Berlin a small  
hinged cover gives very convenient access to the universal-joint  
on the drive shaft for purposes of inspection and lubrication, as

shown in Fig. 2, and immedi-  
ately in front of this cover a  
small differential gear is placed  
inside of the universal-joint  
housing, forming a part of the  
cross shaft from which the  
rear wheel brakes are actuated.

It is not necessary to re-  
move the main cover plate on  
top of the gear box in the 13-  
30-horsepower Lorraine-Diet-  
rich car in order to replenish  
its supply of grease. A small  
cap secured with an easily un-  
done bayonet joint, as shown  
in Fig. 3, can be removed for  
this purpose, when only one of  
the footboards is raised.

The water pump and the  
ventilator fan work on the  
same shaft, both driven by  
gear from the camshaft, in the  
17-40-horsepower Dixi car, as  
shown in Fig. 4, and the pump  
can be removed by undoing a  
few screwbolts. The fan has  
only two blades, in aeroplane  
propellers.—From *Automobil-  
welt*, November 22.

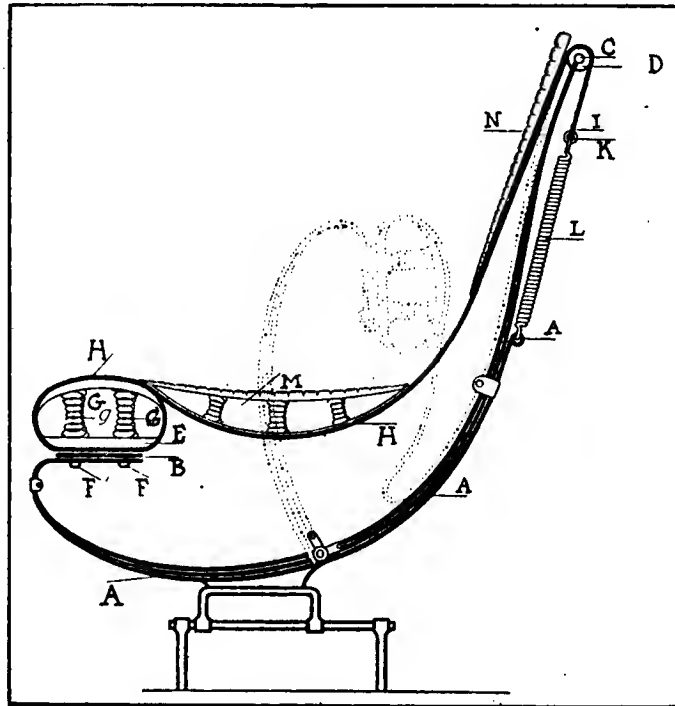

Fig. 1—German novelty in automobile seats

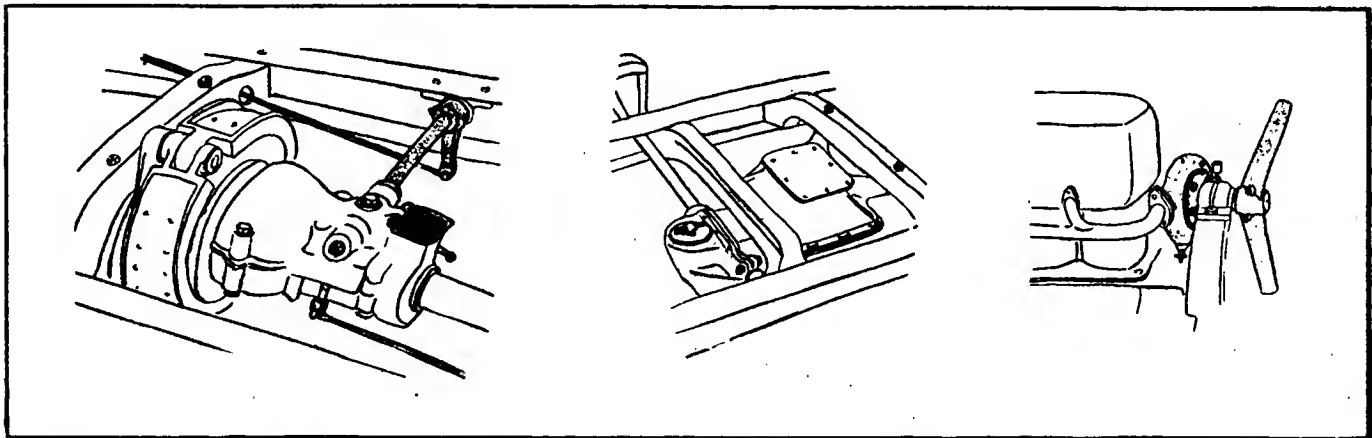

Fig. 2—Hinged cover on Renault universal joint

Fig. 3—Cover plate on Lorraine-Dietrich gear box

Fig. 4—Two-blade of Dixi car

# Keeping Cooling Water from Freezing

**A**MONG the apparent paradoxes of automobiling the use of anti-freezing solutions holds a prominent place. The same motorist who is troubled in summer by the problem of cooling his water to a sufficient degree, so as to relieve the cylinder walls of the surplus heat which cannot be utilized, is faced in winter by the alternative of either using a specially mixed cooling solution or run the risk that the cooling water should grow too cold to be of use. But there is really no paradox at all. In either case the proposition is to keep up the flow of a liquid cooling medium through the cylinder jackets and to remove by means of the liquid just enough heat to keep the walls at the most advantageous temperature.

To prevent the freezing of the cooling water, a number of chemicals have been proposed to be mixed with the water. The prescriptions recommended and used are of varying value, and their worth is determined by three conditions:

1. The freezing point of the mixture should be low enough to insure the liquid remaining in that state at all temperatures encountered in a given climate.
2. The boiling point of the mixture should be as near to that of water (212 degrees Fahrenheit) as possible, to give an approximately equal cooling effect.
3. The use of the mixture should bring about the least possible chance of incrustation or formation of scale in the cylinder jackets.

As to the various anti-freezing solutions known and used at this time, they are chloride of calcium, chloride of sodium (salt), denatured alcohol, glycerine and sugar. By considering each of these materials as to how they fulfill the conditions outlined above little difficulty will be found in settling upon the anti-freezing solution best adapted to the requirements of the motorist.

Before considering these various chemicals and their effects upon the cooling-water of an engine it will be well to remember that the principle of using as pure water as possible, which every autoist strictly adheres to in his summer practice, should not be violated to any large extent in winter. Now, in summer everybody is eager to use perfectly pure water, and since distilled water is too expensive to use for the purpose, rain water is in great demand and used wherever it may be had. If this is not the case, a cautious motorist will use water which has been boiled and thus made soft. Soft water contains no calcium and magnesium salts in suspension; as rain water contains only what it had a chance to dissolve on its fall through the air, *i. e.*, a trace of carbon dioxide, and by boiling water the calcium and magnesium bicarbonates contained in it become insoluble and settle at the bottom of the vessel as a fine powder. Whenever water containing calcium and magnesia salts and carbon dioxide is boiled, the insoluble carbonates of lime and magnesia are formed, and if large quantities of these materials are present, they will lead to the formation of a scale.

A simple test to show whether water is soft or hard is to wash one's hands in a sample of the water in question. If it is hard, it will be next to impossible to produce foam with soap, while soft water will give plenty of clean foam.

Chloride of calcium reduces the freezing point of water considerably, as may be seen by referring to the accompanying table 1. The boiling point of water is raised by mixing chloride with it, and it may be said, in general, that the lower the freezing point of a watery solution of a material the higher is the boiling temperature of the solution. In dissolving the material absorbs large quantities of heat and thereby lowers the freezing temperature of water. If the water is transformed into

steam, the salt dissolved in it is again transformed to the solid state and, giving off thereby the amount of heat formerly absorbed, raises the boiling point of the water correspondingly. Thus the cylinder walls are permitted to reach a much higher temperature before the water is evaporated, and while such a temperature, if it is kept up, reduces engine efficiency, a good radiator will keep the water from evaporating to a perceptible degree. Chloride of calcium will not corrode the cylinder nor jacket walls, unless it reacts acidic, in which case its solution reddens blue litmus paper. But, like most other salts, chloride will do harm to the radiator by acting as an electrolyte and gradually dissolving portions of the solder elements. Although the general belief is in opposition to the statement, the fact is that calcium chloride causes a formation of scale in the jackets, if it is used for some time. The reason therefor is the small carbon dioxide content of the water, which brings about the formation of carbonate of lime. Even if pure water is used to make the solution, the carbon dioxide will find its way into it and be dissolved by it in course of time. It is not so very improbable that some carbon dioxide, which has a very fine molecular structure, leaks through the pores of the cylinder walls, by-and-by enriching the carbonic-acid content of the water and later on leading to scale formation.

If scale is to be removed from the jacket spaces, this may be done by either mechanical or chemical means. In the first case, the jackets are taken off the cylinder, and scale scraped off them, taking care that the jacket and cylinder walls are not damaged by too violent blows. If the scale is to be gotten off in a chemical way, the jackets should be filled with dilute muriatic acid. But if this is done the acid should be left in the jacket spaces no longer than is necessary to dissolve the scale, as corrosion of the metal surfaces will be the result of this practice.

Scale formation is prevented by the use of common salt (sodium chloride) instead of the calcium compound. The sodium salt is very similar in its behavior to the calcium chloride, but the normal product of the market never reacts acidic, so that there is practically no chance of its corroding the jacket surfaces. Nor will it under any circumstances lead to scale formation, since all sodium salts are soluble in water. Even if the water should evaporate and the salt be deposited in a solid form, it will dissolve as soon as water is again admitted to it. As to its freezing efficiency, it is not quite as good as calcium chloride, but will serve almost as well and fill every need despite the inclemencies of winter in any locality of the temperate zones.

TABLE 1.—FREEZING TEMPERATURES OF CALCIUM AND SODIUM CHLORIDE SOLUTIONS OF VARIOUS CONCENTRATIONS

Contents of Compound in Water in per Cent.	Freezing Temp. Cent. Sodium Chlor.	Freezing Temp. Cent. Calcium Chlor.
5	— 3.8	— 2.5
10	— 7.4	— 5.6
12	— 8.9	— 7.0
15	—11.0	— 9.6
20	—14.4	—14.8
25	—17.7	—22.1
30	—20.4	

The principal advantages of liquid anti-freezing mediums are that they leave no residues if the water evaporates, and that they cannot corrode any metal parts of the circulation system. The virtues of alcohol dissolved in water for anti-freezing purposes are not to be denied. Denatured alcohol, and sometimes wood alcohol, is used for this purpose and the anti-thermal values of various water-alcohol mixtures are given in the following table, the values being, however, only approximate.

TABLE 2.—FREEZING POINTS OF ALCOHOL-WATER SOLUTIONS OF VARIOUS CONCENTRATIONS

Quarts of Alcohol per Gal. Water	Alcohol Content in per Cent.	Freezing Temp. Deg. Fahr.
1	20	10
1½	30	—5
2½	40	—20
4	50	—35

The trouble with alcohol is that it evaporates more rapidly than water, so that after running the motor on an alcohol-water cooling solution for some weeks, unless the radiator is perfectly tight, most of the alcohol will have disappeared. To make sure that the qualities of the alcohol still warrant its use, it should be tested for its density from time to time. Some very handy instruments are available in the market, of which mention should be made of the so-called Freezometer, which can be procured for a small sum.

Another disadvantage of alcohol is that the denatured product has been put into that condition by mixing with it such materials as pyridine, which in no way go to improve the smell of the oft-abused commodity. At the same time it should be carried in mind that alcohol is combustible, and if it is not carefully watched, might cause considerable trouble in this direction.

Glycerine has a very low freezing-point and boils at a high temperature, both of which features would tend to make it a desirable anti-freezing substance. If, however, the commercial, not the chemically pure, product is used, for the sake of its low price, the fatty acids contained in it will spell disaster to the tender metallic portions of the cooling system, especially the

radiator. On the other hand, pure glycerine is very expensive, and rapidly dissolves all impurities it comes in touch with, so that pretty soon the cooling system of the motor will be bound to suffer if glycerine is introduced. It has the one advantage in common with salt solutions that it does not evaporate like alcohol, and in refilling the cooling system only pure water has to be added.

Some experiments have been made as to the usefulness of lubricating oil as a cooling medium, but they have not been successful. Oil has a low specific heat, and while its freezing point is low enough to insure the oil remaining liquid at all practical temperatures, its boiling point is likewise low, so that only comparatively small quantities of heat may be carried to the radiator by a given volume of oil. Furthermore, if air is caught in the piping system, a great deal of the hot oil will be burned and the resulting odors will be found far from pleasant by the occupants of the car.

All things considered, common salt, *i. e.*, sodium chloride, may be looked upon as the cheapest and best anti-freezing chemical. Nevertheless, a great number of automobilists prefer other compounds, partly because they have to pay more for them, and partly because the foregoing statement sounds too good to be true. There are few people who understand that the commonest are the most important materials in life as well as in automobiles, and that, for instance, air and water are the most precious and effective foods, even if we cannot live on them alone like the lilies.

## Calendar of Coming Events

### Shows

- Dec. 30-Jan. 6.....Buffalo, N. Y., Annual Show, Seventy-fourth Regiment Armory, Buffalo Automobile Trade Association.
- Jan. 2-11.....New York City, Hotel Astor, Importers' Salon.
- Jan. 6-13.....New York City, Madison Square Garden, Twelfth Annual Show, Pleasure Car Division, Automobile Board of Trade.
- Jan. 6-20.....New York City, Madison Square Garden, Annual Show, Motor and Accessory Manufacturers.
- Jan. 10-17.....New York City, Grand Central Palace, Twelfth Annual Show, National Association of Automobile Manufacturers; also Motor and Accessory Manufacturers.
- Jan. 13-19.....Milwaukee, Wis., Auditorium, Fourth Annual Show, Milwaukee Automobile Dealers' Association
- Jan. 13-27.....Philadelphia, Annual Show, First and Third Regiment Armories, Philadelphia Automobile Trade Association.
- Jan. 15-20.....New York City, Madison Square Garden, Twelfth Annual Show, Commercial Division, Automobile Board of Trade.
- Jan. 15-20.....Toledo, O., Annual Show, Terminal Building, Toledo Automobile Dealers' Association.
- Jan. 22-27.....Rochester, N. Y., Annual Show, State Armory, Rochester Automobile Dealers' Association.
- Jan. 22-27.....Detroit, Mich., Wayne Gardens, Eleventh Annual Show, Detroit Automobile Dealers' Association.
- Jan. 22-27.....Providence, R. I., Providence State Armory, Rhode Island Licensed Automobile Dealers' Association, Automobile and Accessories Show.
- Jan. 22-27.....Dubuque, Iowa, Annual Show Dubuque Automobile Dealers' Association.
- Jan. 27-Feb. 10....Chicago Coliseum, Eleventh Annual Automobile Show under the auspices of the National Association of Automobile Manufacturers. Pleasure cars, first week. Commercial vehicles, second week.
- Jan. 27-Feb. 10....Pittsburgh, Pa., Sixth Annual Show, Automobile Dealers' Association of Pittsburgh, Inc. Pleasure cars, first week. Commercial vehicles, second week.
- Jan. 29-Feb. 3.....Scranton, Pa., 13th Regiment Armory, Second Annual Show.
- Feb. 1-7.....Washington, D. C., Annual Show, Convention Hall.
- Feb. 3-10.....Montreal, Canada, National Show, Drill Hall, Automobile Club of Canada.
- Feb. 5-10.....Buffalo, N. Y., Convention Hall, George C. Fehrman.
- Feb. 5-17.....St. Louis, Mo., Coliseum, Annual Show, Pleasure cars, first week. Commercial vehicles, second week.
- Feb. 12-17.....Ottawa, Ont., Howick Hall, Annual Show, Ottawa Valley Motor Car Association.
- Feb. 12-17.....Kansas City, Mo., Annual Show, Combined Association of Motor Car Dealers.
- Feb. 12-19.....Dayton, O., Third Annual Show, Dayton Automobile Club.

- Feb. 14-17.....Grand Rapids, Mich., Third Annual Show.
- Feb. 17-24.....Pittsburgh, Pa., Second Annual Show, Exposition bldg., Pittsburgh Auto Show Association, Inc.
- Feb. 17-24.....Newark, N. J., Fifth Annual Automobile Show, New Jersey Automobile Exhibition Company, First Regiment Armory.
- Feb. 17-24.....Minneapolis, Minn., National Guard Armory and Coliseum, Annual Automobile Show, Minneapolis Automobile Show Association.
- Feb. 19-24.....Omaha, Neb., Seventh Annual Show, Auditorium, Omaha Automobile Show Association.
- Feb. 19-24.....Hartford, Conn., Annual Show, Automobile Club of Hartford, State Armory.
- Feb. 19-24.....Cincinnati, O., Annual Show, Music Hall, Cincinnati Automobile Dealers' Association.
- Feb. 20-24.....Binghamton, N. Y., State Armory, Third Annual Show, Automobile Dealers' Association.
- Feb. 20-28.....Baltimore, Md., Annual Show, Baltimore Automobile Dealers' Association.
- Feb. 21-24.....Louisville, Ky., Fifth Annual Show, First Regiment Armory, Louisville Automobile Dealers' Association.
- Feb. 21-28.....Toronto, Ont., Annual Show, The Armouries, Toronto Automobile Trade Association.
- Feb. 24-March 2...Brooklyn, N. Y., Twenty-third Regiment Armory, Annual Show, Brooklyn Motor Vehicle Dealers' Association.
- Feb. 26-Mar. 2....Elmira, N. Y., Second Annual Show, Elmira Automobile Club.
- Feb. 26-Mar. 2....Paterson, N. J., Annual Show, Fifth Regt. Armory, Paterson Automobile Trade Association.
- Feb. 28-Mar. 2....Davenport, Iowa, Annual Show, Davenport Automobile Association.
- March 2-9.....Boston, Mass., Tenth Annual Show, Boston Automobile Dealers' Association, Inc.
- March 4-9.....Denver, Col., Auditorium, Annual Show.
- March 4-9.....Denver, Col., Annual Show, Auditorium, Motor Field.
- March 6-9.....Tiffin, O., Second Annual Show, The Advertiser.
- March 12-16.....Syracuse, N. Y., Fourth Annual Show, State Armory, Syracuse Automobile Dealers' Association.

### Meetings, Etc.

- Dec. 20.....New York City, Waldorf-Astoria, Annual Banquet of the Automobile Club of America.
- Jan. 18-20.....New York City, Annual Meeting of the Society of Automobile Engineers.

### Race Meets, Hill-Climbs, Etc.

- Dec. 25-26.....Los Angeles, Cal., Track Races, Motordome.



Vol. XXV Thursday, December 21, 1911 No. 26

THE CLASS JOURNAL COMPANY

H. M. SWETLAND, President
CONDE NAST, Vice-President and General Manager
E. M. COREY, Secretary and Treasurer
231-241 West 39th Street, New York City

WESTERN OFFICE—910 South Michigan Ave., Chicago, Ill.
BRANCHES—Boston, 1036 Old South Building; Cleveland, 309 Park Building;
Detroit, 627 Ford Building

Cable Address Autoland, New York
Long Distance Telephone 2046 Bryant, New York

SUBSCRIPTION RATES

United States and Mexico One Year, \$3.00
Other Countries in Postal Union, including Canada One Year, 5.00
To Subscribers—Do not send money by ordinary mail. Remit by Draft,
Post-Office or Express Money Order, or Register your letter.

Entered at New York, N. Y., as second-class matter.
The Automobile is a consolidation of The Automobile (monthly) and the Motor
Review (weekly), May, 1902, Dealer and Repairman (monthly), October, 1903,
and the Automobile Magazine (monthly), July, 1907.

Prolific Patent Litigation

“ I WOULD readily put over \$50,000 into the manu-
facture of the device, but it is so easy to
make that we would enter immediately into
a prolonged ordeal of patent litigation which would eat
up all of our profits.” This statement, recently made by
the holder of a basic patent on a new device in connec-
tion with the winter use of automobiles, strikes a chord
in the present condition of the automobile industry which
is not at all a pleasant one; namely, the entire disregard
of patent rights in conjunction with many car articles.
It is only within the last few years that what might be
termed an acute situation has arisen in this connection.
At present there are hosts of cases pending in the courts,
which cases are based on patents that in some cases are
comparatively unknown. These patents have been ac-
quired within the last few years and have been held
quietly until the holders had decided whether the in-
fringements were sufficiently general to demand prose-
cution. With several of these patents the owners cannot
but have realized that their claims were not broad enough
to cover what they looked upon as infringements, but
they nevertheless have prosecuted several small makers,
knowing that often a patent case is decided by the size
of the available litigation fund. In other instances the
exact opposite is the case: the patent owners have had
specially broad claims, claims that nearly every infringer
knew would certainly be upheld, but the infringers fig-
ured that the case would occupy many years in court and
during that time there would be ample opportunity to get
all they desired out of the situation. It is unfortunate
that patent litigation is and has been so slow. Often the
life of a patent has almost expired before its validity is
settled. There should not be any necessity for this. It
should not require 15 years to determine whether there
has been any interference, and it should not require 15
years for a few judges to settle what they consider the
actual meaning of the claims and construction of a patent.

A probable solution could be had in the establishment
of a special patent court in which the judges on the bench
would be particularly qualified to readily decide on the
merits of mechanical claims and constructions. The
necessity for such can be seen in the fact that in some
cases judges have reversed their own decisions of a few
months or years previous. Apparently the only reason
for such conditions is lack of familiarity with the prin-
ciples of engineering underlying the cases at issue. To
settle many intricate patent litigation suits has called for
specially clear insight into matters technical, and it is
scarcely expected that different judges should be able to
act with dispatch in such cases.

\* \* \*

Shows and Contests Pay

France has relented: She is going back to the annual
show and she is going back, if she can, to the Grand
Prix road race. Both are for 1912. It is only a few
years ago that the French makers stood up and said to
the remainder of the automobile world that they did not
need an annual show; that it was only a bill of expense
to them; and that, by inference, their products were so
far in advance of those of other countries that special
exhibition of them was not needed more than once in two
years. The Englishman, who was caught napping in the
early days of the automobile, saw the lapsing of France
and jumped into the gap with his international Olympia
and got away with the goods. The Frenchman has at
last realized the situation and now wants the annual show.
Next fall there will be the rival displays on either side
of the channel. What the outcome will be is not of par-
ticular interest on this side of the Atlantic just at present,
as it will not affect either the New York or Chicago
shows whether there are two big shows in Europe or if
there are half a dozen. There is one big point that does
interest American automobile builders, however, and that
is that a show is a necessary factor in the industry to-
day. During the last 6 or 7 years there have been a few
makers who felt that they did not have to go to shows to
sell their product. Several have seen the error of their
ways and are getting into the show circle this year. Many
makers who have done good business for the last couple
of seasons have been talking about the futility of shows,
but these people had better beware. The experience of
the Frenchman is a good one to ponder over and to take
lessons from. This is an age of publicity and it does
not call for many consecutive months of obscurity to let
a maker of renown fall out of public approval. The
shows are great publicity features; they focus the atten-
tion of the entire nation on the automobile, and although
the sales may not be as large as desired the results can-
not be counted by actual sales made. The results of show
work extend through the following 6 months of selling.
The maker who exhibits may not know this so well as the
maker who does not exhibit. During the show period
there is a mass of missionary work done. The selling
seed has been dropped into soil of unexpected fertility
and the harvest has always been a good one. The shows
and contests constitute excellent vehicles for keeping the
automobile in the public eye and both should be encour-
aged and sustained. There are many examples of foolish
prodigality during show weeks. This can be eliminated
and the value of the show not reduced in the least.



## All Jersey Working for Sane Law

THE following notice as to the legal situation in New Jersey has been issued by the joint legislative committee representing all the warring factions of New Jersey motordom.

All motorists in New Jersey are vitally interested in automobile legislation that has for its principle "that motorists from other states desiring to tour in New Jersey shall be permitted to do so for a limited period of time without requiring them to take out registration or sign power of attorney, when they have been properly registered in their own state, provided that state extends the same privileges to the motorists of New Jersey," and they will remember the strenuous efforts that were brought forth last year to have the Legislature pass a reciprocity bill and the fact that it was defeated in the Senate by only one vote, the vote being a tie.

It should be a great satisfaction for them to now learn that through organization special efforts are being put forth this year to secure the legislation that they all so much desire, and they will no doubt be interested to learn that the principal and largest automobile organizations of the state, representing every shade of opinion among organized motorists, both from the trade as well as owners of automobiles, have gotten together on this subject, and there has been a joint committee appointed.

This committee is known as the Joint Legislative Committee of the Automobilists of New Jersey, and has full power to take charge of the proposed automobile legislation this Winter in the interests of all motorists, irrespective of club affiliations, and they have every hope that the labors of this committee will be crowned with success, and that the present unfavorable attitude of the New Jersey law in regard to visiting motorists will be done away with and that we shall have reciprocity between the various states.

The Joint Legislative Committee of the Automobilists of New Jersey is composed of five representatives from the New Jersey Automobile Trade Association, five representatives from the Associated Automobile Clubs of New Jersey, and five representatives from the New Jersey Automobile and Motor Clubs.

The representatives from the New Jersey Automobile Trade Association are as follows:

Geo. Blakeslee, Geo. H. Smith, Louis Fitzgerald, W. H. Ellis, Geo. Paddock.

Those from the Associated Automobile Clubs of New Jersey are as follows:

W. Eugene Turton, Jos. H. Wood, W. Clive Crosby, J. H. Edwards, Geo. Post.

Those from the New Jersey Automobile and Motor Club are as follows:

Richard C. Jenkinson, G. O. Groebe, Ira Kipp, Jr., Horace P. Cook, Melville A. Carpenter.

If New Jersey is not brought back into the automobile "union" this Winter, it will not be due to the failure of the motorists of this state presenting a united and determined effort or the failure of an earnest and hard working representation.

### Michigan Law to Be Sharply Tested

DETROIT, MICH., Dec. 18—The constitutionality of the Michigan law which holds the owner of a motor car responsible for damage done by his machine unless he can prove that the machine had been stolen from him, was attacked in the Federal court here last week, in the suit brought by John Parrott, of Mt. Clemens, against the Metzger Motor Car Co., arising out of an accident on the Gratiot road some time ago. Judge Angell strongly intimated that he believed the point well taken, but

preferred to leave the determination of the question to a higher court. Accordingly he permitted the case to go to the jury, which brought in a verdict for \$1,843 against the Metzger Co. It is certain that the case will be appealed.

Parrott was driving a team from Detroit to Mt. Clemens on the Gratiot road, when an automobile, owned by the Metzger Motor Car Co., and driven by one of its employees, crashed into the farmer's cart, overturning it, killing one of the horses and injuring Parrott. The company admitted ownership of the car and lack of negligence on the part of Parrott, but denied responsibility for the accident on the ground that the driver of the car was using it without permission. On this theory, Attorney Brennan, representing the Metzger Co., moved the court to direct a verdict of no cause for action, but as this was the first time the constitutionality of such an act had been questioned he was unable to find any decisions covering the point.

Judge Angell acknowledged that, in overruling the motion, he acted with some hesitancy because the motor car seemed to be legislated against in this instance.

"The motor car is not like dynamite or nitro-glycerine," said the court. "We who live in Detroit are familiar enough with it to know that it has no inherent qualities of danger. The same degree of responsibility does not attach to the owner of a horse and wagon, and it seems unfair to place the owner of an automobile in a special class."

In his argument to the court, Attorney Brennan said:

"It is class legislation when a man, because he has money enough to purchase an automobile instead of a horse and buggy, is put in a separate class with heavier responsibilities. The law of Michigan which makes an automobile owner responsible for damage done by his machine unless he can prove that it was stolen and can prove the intent of the thief, puts every automobile owner at the mercy of the hoodlums of the street who 'borrow good people's machines to go joy-riding.'"

Judge Spier, of Mt. Clemens, who appeared for the plaintiff, defended the law on the ground that the state has power to make police regulations for the protection of citizens against careless and reckless driving of motor cars. If persons sustaining damage were unable to recover from the owners of motor cars they would be unable to get redress from any source, he declared.

It is understood that the Metzger Co. is determined to take the case to the Supreme Court of the United States, if necessary. The first appeal will be to the Circuit Court of Appeals at Cincinnati.

### Jersey Mayors to Abolish Death Traps

Grade crossings in New Jersey are to be abolished, root and branch, if the purpose of the mayors of various cities in the State is carried out. The mayors will form an organization Jan. 6, at Trenton. A preliminary meeting was held Tuesday at East Orange where the determination to form an association was crystallized. Under the plan it is intended to abolish grade crossings in counties of the first class by July, 1914, and throughout the State by 1920.

A bill will be drafted for presentation to the coming legislative session.

MANY TOO LATE—Inquiries are being received daily regarding the reservation of space at the Madison Square Garden show. This is one of the cases where the early birds have made away with the worm as the space has long since been completely closed out.

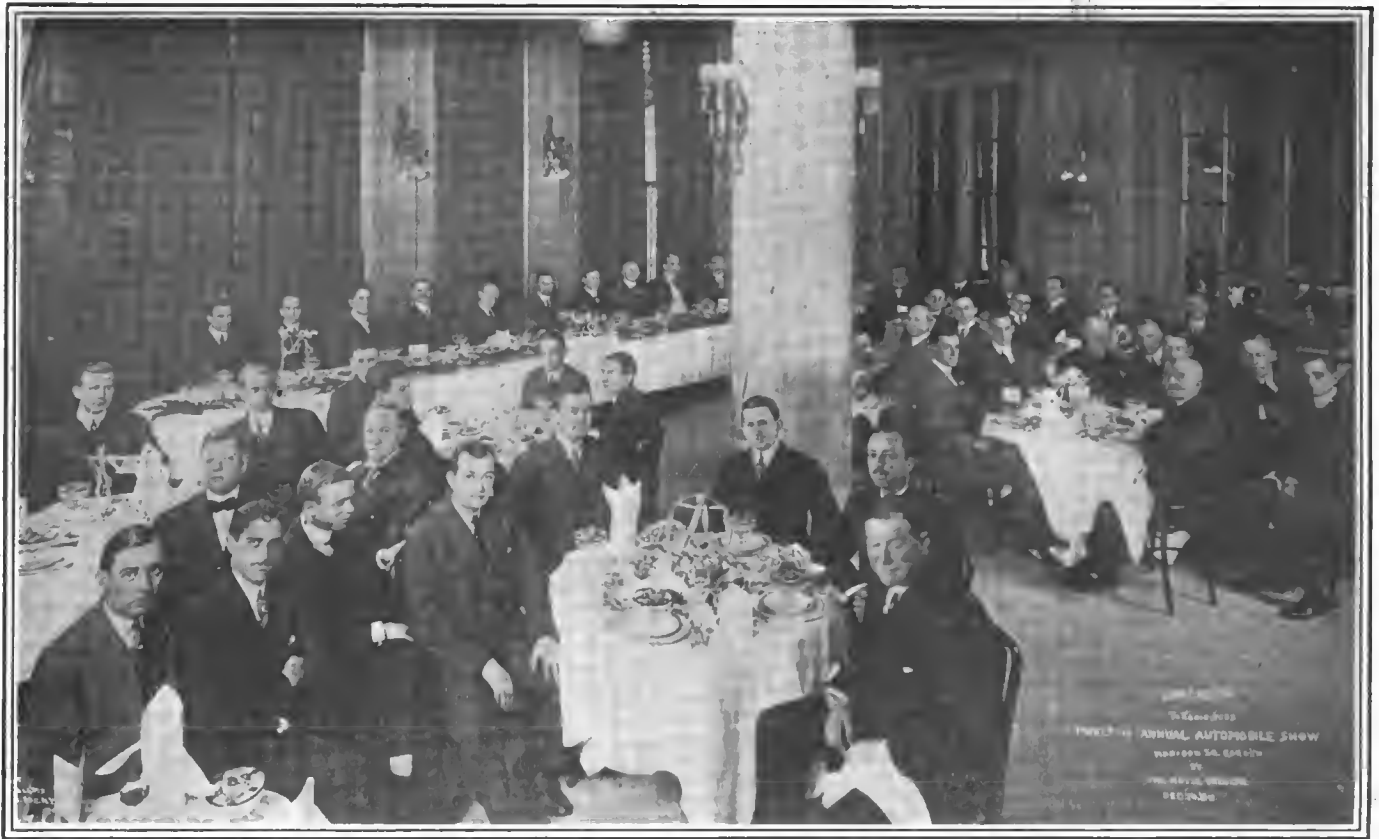

Luncheon given by Hotel Breslin management to exhibitors at the Garden Show

## News of Shows, National and Local

WHEN Madison Square Garden throws wide its doors for its last function—the Twelfth National Automobile Show on January 6—hundreds of motoring enthusiasts will have opened to them the most magnificent and biggest automobile display ever seen in the nationally famous building.

For 1912 the pictorial idea is that of a mammoth Oriental garden. The color scheme is to be crimson and gold with smatterings here and there of blue, green and white.

The exhibition spaces on the main floor, elevated platform and balcony will be carpeted with a specially woven fabric of green hue giving the appearance of the cars reposing on grass. Entering from the foyer the visitor will be confronted by a huge fountain. Back of the fountain, in the center, is a statue representing The Motor Era. The water from the fountain will be electrically radiant, made so by iridescent and hidden electric bulbs. All about the fountain are eight allegorical figures 10 feet high arched by garlands of natural flowers. Six bay trees are recessed in the front of the fountain. Beyond this fountain will extend the main display space.

The plan of having the elevated platform and balcony above the arena boxes

project over the main floor and of covering the high rear seats so as to make a sort of mezzanine floor will be repeated.

A novel feature of the decoration this year will be the treatment of the ceiling which will have the appearance of an inverted oriental rug with rich coloring and treatment. This gigantic painting will cover the steel girders of the ceiling and will gracefully hang down the sides. The total weight of the canopy is more than 3 tons. The figure in the center panel of the painting represents the triumph of the industry. The panel measures 100 by 200 feet.

Plans for the new arena, which in future will augment the space available for show purposes of the Grand Central Palace, will be completed Saturday night and will be submitted to the New York Central Railroad and the management of the palace immediately afterward.

Several changes have been made in the draft first prepared and the present plans contemplate a building more commodious in every way than the one originally considered. Dates for actual commencement of work will be announced in the near future.

Invitations are being prepared by the management of the N. A. A. M. show at the Palace for all the exhibitors who will show at the Garden, and on opening night

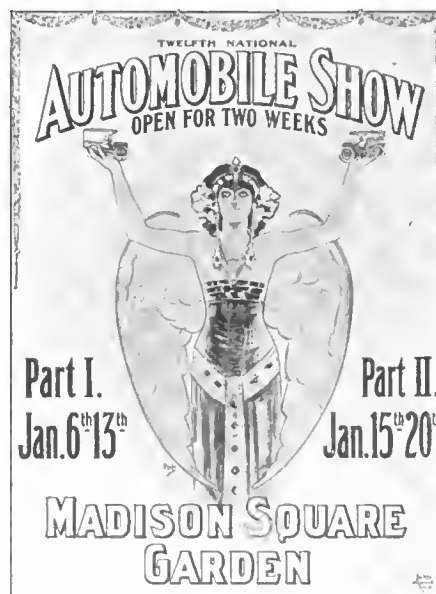

Poster for the Garden Show

it is expected that the Board of Trade exhibitors will attend in a body.

Tuesday and Thursday have been designated during show week as society nights and special preparations have been made to arrange suitable programs.

### A Score of Exhibitors at the Salon

The twenty different makes which will be exhibited at the Importers' Automobile Salon include every foreign car which has achieved distinction either in this country or abroad. The English Daimler, Panhard, Mercedes and Minerva exhibits will include models having Silent Knight sliding sleeve-valve motors, while those of the Itala and Darracq will have models with new rotary valve motors. The latter are entirely new to the automobile public in this country and will attract much attention from the visitors to the Salon.

It is perhaps the magnificent bodies, particularly those of the inclosed type, mounted on the various chassis exhibited at the Salon, which are of the greatest interest. They are the products of the well-known body builders of Europe and America, whose names are synonymous with ultra-luxuriousness.

### New Cars to Make Their Bow at Detroit

DETROIT, MICH., Dec. 18—Detroit's Eleventh Annual Automobile Show, to be held in the Wayne Gardens and the new Annex, 108 feet wide by 165 feet long, promises to be without any doubt America's leading local show and the largest local exhibition in the country if not the most important. The trade of Detroit accepted readily the proposition of the D. A. D. A. to construct this building providing they would take space.

It is known generally that a great many of the Detroit exhibitors will display for the first time new cars, which they will not have ready for the New York show; but which will be completed in time for Detroit and Chicago and later shows.

### Change of Plans at Philadelphia

PHILADELPHIA, Dec. 18—A radical departure in the plans for the second week of the local Automobile Show has been announced, necessitated by reason of the large number of applications for commercial vehicle space. Originally being the intention to confine the motor truck display to the Third Regiment Armory, during the second week, January 22 to 27 inclusive, the revised plans comprehend the exhibition of commercial cars at the First Regiment Armory, in addition; thus the show in the latter building, instead of being devoted exclusively to electrics, will consist of electric pleasure cars and equipment and of commercial cars.

### National Will Show in Breslin Lobby

Out of a field of twenty-one, W. C. Poertner, of the Poertner Motor Car Co., handling the National line in the metropolis, drew the lucky number at the annual luncheon tendered to the automobile trade in New York by the management of the Hotel Breslin, and as a result the National company will have the privilege of exhibiting one of its models in the lobby of the hotel during the coming show.

S. A. Miles presided and the speakers included: Alfred Reeves, H. A. Bonnell, A. G. Batchelder, M. L. Downs and several others.

### News of Other Local Shows

BALTIMORE, MD., Dec. 16—The Baltimore show will be held February 20 to 28, inclusive, under the joint auspices of the Automobile Club of Maryland and the Baltimore Dealers' Association. The Fifth Regiment Armory has again been secured.

Commercial cars will be shown on the last three days of the show exclusively, the first five days being devoted to pleasure vehicles. Dealers in accessories will have their exhibits on hand on all of the eight nights of the show. The joint committee will consist of Dr. H. M. Rowe, president of both the Club and Dealers' Association, chairman; Joel G. Nassauer, Thomas G. Young, H. K. Luzius and John B. Bridges, representing the club and R. J. W. Hamill, A. S. Zell, F. S. Bliven and W. L. Duck, representing the dealers.

SIoux CITY, IA.—The annual automobile show under the auspices of the Sioux City Automobile Dealers' Association, will be held in the latter part of February, or early in March. As the Omaha show is from February 19 to 24, and the Des Moines show, March 4 to 9, it is planned to hold the Sioux City show between these shows. C. M. Wyckoff was re-elected as president of the association. The other officers are: H. A. Wetmore, vice-president; Ralph Wigton, secretary; F. H. Reid, secretary; executive committee, H. B. Groves, H. A. Wetmore, and S. C. Douglas.

TOLEDO, O., Dec. 18—The approaching Toledo Automobile Show promises to eclipse anything of the kind ever undertaken here. Exhibitors are enthusiastic, and all available space will be taken by the concerns handling cars and accessories. An extensive advertising campaign throughout northwestern Ohio will be inaugurated, and indications for success are of the brightest. The Terminal building, which was selected as a location for the show, is being prepared and beautified, and nothing will be left undone by the managers of the exhibition to attract the attention of the public generally.

DAYTON, O., Dec. 15—Committees representing the Dayton Automobile Club and the automobile dealers of the city have selected Elmer C. Redelle, manager of the Dayton baseball team, to take charge of the annual automobile show, which will be held February 12-19. The club committee is composed of William Stroup, Walter Kidder, E. A. Deeds and Walter Kuhns. The dealers are represented by George L. Baker, William H. Yeazell, Earl Hosler, George W. Shroyer and G. G. Peckham. Plans for the show will be begun at once. The show will be the third held in Dayton.

CLEVELAND, O.—Automobile manufacturers and dealers and the Cleveland Automobile Club will work jointly this year toward the success of the Cleveland automobile show to be held in Central Armory, February 17 to 24, inclusive. Frank W. Philips resigned as chairman of the show committee recently. H. M. Adams was chosen to fill the vacancy. Fred H. Caley, secretary of the Cleveland Automobile Club, was named as manager of the show by the show committee.

SYRACUSE, N. Y., Dec. 16—The Automobile Dealers' Association is perfecting plans for the third annual automobile show in the Armory in March. An effort is being made to find a place of exhibition for trucks and accessories, because of the heavy demands for space made by manufacturers of passenger cars.

MILWAUKEE, WIS., Dec. 18—Space for the fourth annual Milwaukee show, to be given by the Milwaukee Automobile Dealers' Association in the Auditorium, Jan. 13 to 19 inclusive, was allotted last week and the results show that there will be seventy pleasure car exhibits, thirty of commercial cars and fifty-one of accessories.

DES MOINES, IA.—Des Moines had a small-sized automobile show last week as an adjunct of the state convention and show of the Iowa Implement Dealers' Association, at the Coliseum. Many of the dealers showed automobiles along with their implements.

BUFFALO, Dec. 18—Space in the second automobile show of the Buffalo season will be allotted December 29. The show will be held in Convention Hall, February 5-10. The enterprise is under the management of George C. Fehrman.

DUBUQUE, IA., Dec. 18—Dubuque automobile dealers have formed an association for mutual protection. They also propose to hold an automobile show during the week commencing January 22, 1912.



Auto delivery equipment of a Dayton, Ohio, department store, all supplied with Apleo Model A3 electric lighting system

**DETROIT, MICH.**—The Wolverine Motor Supplies Co. has increased its capital from \$10,000 to \$25,000.

**MONTREAL, QUE.**—The Motor Import Co., Ltd., has taken the agency for the Hupmobile in this city.

**CHARLOTTE, N. C.**—J. D. and M. W. Woodside are arranging to build an automobile repair shop and garage.

**WASHINGTON, D. C.**—Emerson & Orme, 1407 H street, N. W., have added the Fiat to their line, which consists of the Apperson and Detroit Electric.

**LINCOLN, NEB.**—H. E. Mason, formerly with the Shamp Implement Co., has purchased an interest in the Sidles Motor Co., succeeding G. E. Swope as manager.

**WASHINGTON, D. C.**—C. Cassard Schroth, agent for the Stearns, has taken quarters with the Wilson Co., 918 Fourteenth street, N. W. The latter handles the Cole and Krit.

**SPOKANE, WASH.**—The Mitchell automobile will be represented by the Metropolitan Motor Car Co. Manager Harry Bell recently announced the relinquishment of the Marion.

**NEW YORK CITY**—The Schildwacher Carriage Co., 128th street and Park avenue, has taken the eastern agency for the Sternberg truck. The company also handles the McIntyre power wagon.

**AKRON, O.**—The B. F. Goodrich Co. announces the opening of three new branches in California, at Fresno, Oakland and Sacramento, these being in charge respectively of the following managers: R. W. Peters, H. S. Smith and H. W. Schoenlaub.

**ATLANTA, GA.**—The Southern branch of the White Co. has followed the trend of

the times and opened a show room on Peachtree street. The present garage and machine shop on Marietta street will be used as before.

**LOUISVILLE, KY.**—F. E. Van Patton has been selected as the manager of the new branch of the Ford Motor Co. Before coming to this city Mr. Van Patton was assistant manager of the Cleveland branch of the Ford Motor Co.

**BOSTON, MASS.**—The Matheson Co. has secured the new building erected for the Alco and Stoddard-Dayton on Commonwealth avenue recently, and which was vacated when those two cars were changed from agencies to branches.

**PHILADELPHIA**—The Gomery-Schwartz Motor Car Co., local distributor of the Hudson, has removed from the southwest corner of Broad and Callowhill streets to larger and more modern quarters at Nos. 253-255 North Broad street.

**MILWAUKEE, WIS.**—T. A. Brinn, formerly head of the motor assembly department of the Wisconsin Motor Manufacturing Co., has taken a similar position with the Beaver Manufacturing Co. The Beaver company has been reorganized recently by General Manager Lewis.

**WASHINGTON, D. C.**—E. C. Bull has resigned as manager of the Pope Automobile Co., agents for the Pope-Hartford and Marathon, to accept a position with the New York branch of the Lozier Motor Co. He has been succeeded by H. N. Dewitt.

**TACOMA, WASH.**—The past week there congregated in Tacoma all the Jackson automobile dealers of the Northwest, who came to view the latest models turned out by the Jackson Automobile Co. They

were the guests of Northwest Manager F. E. Cady.

**DENVER, COL.**—The Denver Motor Club has leased Overland Park for 5 years. The organization will have one of the best equipments in the country including all the conveniences and luxuries of a country club and a race track which will be banked and prepared for speeding.

**PHILADELPHIA**—The Streator Motor Car Co., of Streator, Ill., manufacturer of the Halladay car, has opened an Eastern distributing sales agency at Fifteenth and Oxford streets in this city. The agency's territory will comprise Pennsylvania, New Jersey, Delaware and Maryland.

**MILWAUKEE, WIS.**—The KisselKar Co., representing the Kissel Motor Car Co., of Hartford, Wis., in Wisconsin and several other states, has moved into its new garage and salesroom building at 176-178-180 Seventh street. The new building cost \$45,000. Frank J. Edwards is manager of the company.

**MILWAUKEE, WIS.**—Raymond C. Agner, of Burlington, Wis., inventor of an oil and grease gun and other motor car specialties, tools, etc., has been granted patents on an adjustable spark plug wrench, to be marketed under the trade mark of Simplex. It will be manufactured by Mr. Agner's company at Burlington.

**MILWAUKEE, WIS.**—C. A. Hamilton, for six years vice-president and manager of the Wisconsin Engine Co., of Corliss, Wis., has resigned to become associated with the Lavigne Gear Co. of Milwaukee, a reorganization of the Lavigne Gear Co. of Detroit, which recently established a plant at Corliss to manufacture steering gears and has taken quarters in Milwaukee to be used as general offices.

REDMOND, ORE.—Powers & Hess are installing an automobile repair shop here.

MONTREAL, QUE.—The Pope-Hartford Co. of Canada will handle the Pope-Hartford in this city.

RIPON, WIS.—Edward Bobzin, proprietor of the Bobzin Garage, has taken the agency for the Buick in this territory.

NEW YORK CITY—The J. I. Case Co., of Racine, Wis., has opened a branch at 1850 Broadway. O. A. Lewellen is in charge.

TORONTO, ONT.—The McLaughlin Carriage Co. of this city are agents for the Fiat car and for the Rauch & Lang electric.

NEW YORK CITY—H. E. Steinbock has severed his connection with the engineering department of the United States Motor Co.

ERIE, PA.—G. H. Henry has bought out the interest of his partner, E. A. Semmence, in the Hupmobile Sales Co., of 1319 Peach street.

KANSAS CITY, MO.—A new brick garage is to be erected at 1713 McGee street by McGilroy & Bowling. The building will cost \$4,000.

MONTREAL, QUE.—E. Major, 37 St. Catherine street West, has been appointed Canadian representative of the Delaunay-Belleville car.

MONTREAL, QUE.—Automobile Francais is the name of the company which has taken the agency for the Renault, Berliet and Gregoire cars.

CINCINNATI, O.—William Duffy, formerly with the Motor Supply Co., of this city, has associated himself with the Fisk Rubber Tire Co., 816 Main street.

MONCTON, N. B.—The International Automobile Co. of Moncton has been incorporated to deal in automobiles. The company is capitalized at \$50,000.

MONTREAL, QUE.—The National Motor Co. of Canada, Ltd., has changed its name to the Windsor Auto Garage & Engineering Co. and will devote itself entirely to the garage business.

CINCINNATI, O.—The Chas. Behlen Sons Co., distributor of the Locomobile and the Detroit Electric, is making extensive improvements in its showroom at Fifteenth and Vine streets.

FREMONT, O.—The Lauth-Juergens Co., of this city, has appointed the following agents: Mutual Auto Co., Duluth, Minn.; P. A. Brink, Los Angeles, Cal., and A. S. Lascelles & Co., New York.

PROVIDENCE, R. I.—The 1912 Alco limousines are equipped with marine windows which, beside relieving the car's continuity of line, enable the driver to obtain an unobstructed view to the rear.

CINCINNATI, O.—The first six-cylinder police patrol to leave the Packard factory was recently delivered to the local police

department. The body is mounted on a standard with extra-heavy springs.

ROCHESTER, N. Y.—William Knipper, who drove a Mercer in the recent races at Savannah, Ga., has retired from the field of automobile racing and has taken the agency for the Stutz car in this territory.

WASHINGTON, D. C.—The Overland-Washington Motor Co. has been appointed agent for the Garford line of pleasure cars and trucks. Considerable territory in Virginia and Maryland has been given the new agency.

FLINT, MICH.—A. B. Hardy has resigned his position with the General Motors Co. as general manager of the Marquette Motor Co., of Saginaw, Mich., to become general manager of the Little Motor Car Co., of this city.

WILLIAMSPORT, PA.—Messrs. Weller and Davidson have organized the Central Garage of Williamsport to do a general machine shop and automobile repair business. They will handle the Matheson car in this territory.

ST. LOUIS, MO.—The Behen Automobile Equipment Co., Kingshighway and Delmar avenue, has commenced business and will handle automobile supplies and accessories. John J. Behen is president and treasurer and S. F. Behen is secretary.

DES MOINES, IA.—The Capital City Carriage Co., Des Moines, agent for the Jackson, has taken uptown quarters. This company has represented the Jackson here for several years but has always conducted the business from the factory.

NEW YORK CITY—Chas. E. Riess & Co., general eastern distributors of the Marion car, and the American-Marion Sales Co., metropolitan distributor of American and Marion cars, have moved into their new offices and salesrooms at 1896 Broadway.

LOUISVILLE, KY.—The Ford Motor Co., of Detroit, Mich., has selected F. E. Van Patton as the manager of its new branch here. Mr. Van Patton has been connected with the company for some time as assistant manager of the Cleveland, O., branch.

STREATOR, ILL.—The Streator Motor Car Co. has appointed the following special factory representatives: L. W. Thompson, Oklahoma and part of Kansas; C. R. Reilly, part of Iowa; F. S. Van Veghten, Nebraska, and the Mound City Buggy Co., Missouri.

BRIDGEPORT, CONN.—Leonard W. Williams, until recently manager of the Oakland branch of the Locomobile Co. of America, has come East to become associated with the advertising department of the Locomobile company. Mr. Williams, prior to his work on the coast, was connected with the Philadelphia branch of the company.

ATLANTA, GA.—The movement to do away with horse-drawn vehicles in all the departments of Atlanta's municipal work goes steadily ahead. The latest addition to the Gate City's fleet is a White Truck for the tapping and construction department of the city waterworks. The sanitary, hospital, construction, waterworks, police and fire departments all use machines and find them much more efficient than horses.

MILWAUKEE, WIS.—The Smith-Hoppe Auto Company, state agent for the Hupp-Yeats electric and local agent for the Oakland and R. C. H., has moved to its new garage at Wisconsin and Cass streets, erected at a cost of \$45,000. The Wisconsin Auto Sales Company, state representative of the National, Herreshoff, Cutting and Westcott, has also taken quarters in the new garage, which is one of the largest in point of one-floor space in the city of Milwaukee.



View of 1912 Alco limousine, showing new marine windows in rear





Packard patrol wagon now doing duty in the Cincinnati police department

AKRON, O.—D. H. Holloway, Central Savings & Trust building, has taken the local agency for the Elmore.

SYRACUSE, N. Y.—The Porter-Cable Machine Company, of this city, is working full night and day shifts to turn out Hanna self starters.

COLUMBUS, O.—F. E. Avery, central Ohio agent for the Packard, will leave in the near future for a four-months' trip through Cuba, Panama and points in the West Indies.

CAMBRIDGE, O.—Otho Prince has secured a patent on an automobile fender which it is claimed is an improvement over the present fenders. The fender is intended to operate automatically.

CINCINNATI, O.—W. C. Woellner has resigned as purchasing agent of the Schacht Motor Car Company to become identified with the Instantaneous Auto Starter Company, in the capacity of sales manager.

INDIANAPOLIS, IND.—The Delaware Garage has started a clearing house for second-hand automobiles. The first sale was held on December 18.

INDIANAPOLIS, IND.—W. W. Bond, for some time city sales manager for the Brewer Auto Company, has resigned and will handle the agency for the Woten electric rectifier in Cook County, Ill.

CLEVELAND, O.—Ray M. Colwell, who recently resigned as local manager of the Buick Motor Co., has incorporated the Start-O Co., with offices at 1636 Walnut avenue N. E. Mr. Colwell is the inventor of the Victor self-starter.

AKRON, O.—Despite the uncertainty of a presidential election and the unsettled conditions usually found throughout the country in such years, Akron rubber manufacturers predict that next year will be the biggest in the history of the industry.

PHILADELPHIA, PA.—The D. Walter

Harper Company, who introduced the Stanley Steamer here in 1903, has been the last to give up the sale of steam cars. It will represent the Case cars, as well as the Cameron air-cooled line of pleasure and delivery models.

BARBERTON, O.—Another rubber factory is soon to start operations here. The old factory building formerly used by the Carrara Paint Company has been sold to Adam Duncan, of Akron, O., and will be turned into a reclaiming plant. Six reclaiming machines will be installed.

PROVIDENCE, R. I.—J. F. Gfrorer has been announced in charge of the service department of the American Locomotive Company. Since joining this organization Mr. Gfrorer has been engaged in special work. Mr. Gfrorer has been associated with the motor industry since 1903.

AUBURN, IND.—Companies known as the Kansas City-Auburn Company and the Omaha-Auburn Company, which will be factory sales branches of the Auburn Automobile Company, have been organized and incorporated. Each company has an authorized capitalization of \$10,000.

NEW YORK CITY—Louis Hendon has been appointed assistant superintendent in the service department of the Thomas Motor Company of New York. Previously Mr. Hendon was superintendent of the Mitchell repair shop here, and more recently had charge of the Packard shop in Savannah, Ga.

DETROIT, MICH.—The position of advertising manager of the Lozier Motor Company will be filled by James M. Evans, the vacancy having been created by the appointment of C. A. Emise as sales manager, to succeed F. C. Chandler, who has been appointed general manager of the Lozier Motor Company.

OMAHA, NEB.—T. V. Graves, of Chicago, has come to Omaha to take charge of

the local branch of the Goodyear Tire Company. He has temporary quarters with the Powell Supply Company, which sold these tires previously. The company expects to move into a new building, now in course of construction at 2212 Farnam street, in a short time.

AKRON, O.—The work of extending facilities for Diamond tire service is still going on, four new service stations having been recently opened—three in the South and one in the Middle West. These new stores are located at 1316-18 Grand avenue, Kansas City; 910 Broadway, Nashville, Tenn.; 229 N. Tryon street, Charlotte, N. C.; 427 S. Twentieth street, Birmingham, Ala.

COLUMBUS, O.—Advance sheets of the annual report of James R. Marker, State Highway Commissioner of Ohio, shows that during the year ending November 15 there were constructed under state supervision 60.88 miles of highway. Of that amount 32.6 miles was water-bound macadam, 8.7 miles bituminous macadam, a small portion concrete and 19.2 miles brick.

MILWAUKEE, WIS.—George W. Browne, 458-462 Milwaukee street, state agent for the Overland and Marmon, last week entertained 52 of his Wisconsin sub-agents at the new Browne service building in Milwaukee. A banquet was given by Mr. Browne in the evening and T. C. Whitcomb, assistant sales manager of the Willys-Overland Company, Toledo, made the principal address.

DAYTON, O.—The Stoddard-Dayton department of the United States Motor Company has decided to centralize its local selling force at the plant and announcement is made of the appointment of Charles Hoffritz as agent. The local agency formerly was in the hands of the Dayton Automobile Company, on West Fourth street. This company will continue in the business and will sell the Winton Six and other lines.

INDIANAPOLIS, IND.—All Indiana agents for the Overland, numbering nearly 100, were entertained by the Fisher-Gibson Company at that concern's salesrooms on December 12. A dinner was served in the salesrooms. Among those present was John N. Willys, president of the Willys-Overland Company, and other representatives of the Overland factory. A theater party was given for the visitors during the afternoon.

INDIANAPOLIS, IND.—Visitors representing hundreds of thousands of dollars' worth of business were entertained last week at the Premier factory. All were Premier representatives at various points in the country and some of them rank among the most prominent automobile dealers in the United States. F. M. McFarland, the leading motor car dealer of Honolulu, was among the number. Premier cars will be shipped to Honolulu for distribution in the Hawaiian Islands on a bigger scale than ever.

DES MOINES, IA.—The Brown Corley Ellis Company has taken the Des Moines agency for the R. C. H. car.

SPRINGFIELD, MASS.—C. J. Clark and J. M. Greenlees have opened an agency here for the sale of K-R-I-T cars.

LOUISVILLE, KY.—The Kentucky Automobile Company has taken the agency for the Standard electric. This concern is also the agent for the Cadillac car.

CINCINNATI, O.—The W. C. Jungclas Company has taken the agency for the Thomas Flyer in this city. This concern also handles the Overland.

LOS ANGELES, CAL.—The Hayes Auto Sales Company has moved into its new quarters at 1225 S. Olive street. It will handle the Hayes and Krit cars.

MILWAUKEE, WIS.—The Pauly, Bruce & Goldacker Company, state agent for the Stoddard-Dayton, has taken the agency for the Universal and Chase truck lines.

SPRINGFIELD, MASS.—The Western Massachusetts Cadillac Company has been formed in Springfield by E. R. Clark, and the new company will handle the Cadillac product.

DES MOINES, IA.—J. E. Ullman closed a contract this week for the local agency for the Ohio car. He will have offices and show rooms with the Independent Auto Company.

LOS ANGELES, CAL.—The Pathfinder Motor Car Company is now located here and will handle the New Parry and Speedwell cars. It has leased the building at Pico and Hill streets.

WASHINGTON, D. C.—G. C. Bensinger & Bro., 301 Sixth street, N. W., agents for the Ohio, have secured the Grabowsky truck agency and will inaugurate a service department in connection with it.

NEW CASTLE, PA.—Patterson & Emery, prominent automobile dealers of this city, have contracted with the Franklin Automobile Company, of Syracuse, N. Y., to handle Franklin cars for the season of 1912.

FOND DU LAC, WIS.—W. C. Reinig was elected president of the Crescent Motor Company at the annual meeting. H. S. Wilson is secretary and treasurer. The company is building a large addition to its plant.

TOLEDO, O.—It is unofficially announced that T. W. Warner, president and general manager of the Warner Manufacturing Company of Toledo, will build a new plant at Muncie, Ind., to be operated by a company called the Warner Auto Parts Company.

BOSTON, MASS.—The Matheson Automobile Company will shortly open a completely equipped service bureau, a branch of the parent company of Wilkes-Barre. A large

building on Commonwealth avenue especially constructed for automobile service has been chartered.

MILWAUKEE, WIS.—The National Brake & Electric Company, of Milwaukee, a unit

of the Westinghouse interests, has increased its capital stock from \$1,000,000 to \$2,000,000. The company manufactures a number of compressed air and electrical devices and equipment for garages.



## Automobile Incorporations

### AUTOMOBILES AND PARTS

ALBANY, N. Y.—Park Automobile Co.; capital, \$1,000. Incorporators: James Holroyd, Joseph W. Koreman, Michael Beck.

ASHTABULA, O.—High Level Auto Co.; capital, \$10,000; to buy and sell automobiles. Incorporators: J. C. Topper, Earl Gardner, T. P. Fitzgerald, S. F. McDonald, Fred Squires.

BRIDGEWATER, MASS.—Wm. H. Bassett Co.; capital, \$20,000; to make automobiles. Incorporators: Wm. H. Bassett, J. Gardner Bassett.

BROOKLYN, N. Y.—Ormond Motor Car Co.; capital, \$100,000; to make automobiles. Incorporators: G. H. Howell, R. McKeller, T. Downs.

BROOKLYN, N. Y.—Royal Automobile Machine Co.; capital, \$10,000; to make automobile parts. Incorporators: Sydney Solomon, Celia Trothstein, Louis B. Brodsky, Wm. M. Abel.

CAMDEN, N. J.—Auto Car Sales and Service Co. to make and sell motor cars.

CANTON, OHIO.—Stark Auto Co.; capital, \$20,000; to sell automobiles. Incorporators: W. H. Burgener, Tbos. C. Huth, Samuel Haenny, George Shaffer, Harlie C. Ellsworth.

CHICAGO, ILL.—F. A. L. Auto Co.; capital, \$2,500; to sell motor cars. Incorporators: Frederick C. Harboer, Clinton S. Lamb, E. W. Landberg.

CHICAGO, ILL.—Simkin Mfg. Co.; capital, \$2,000; to make and sell automobiles, accessories, etc. Incorporators: Albert J. Elliott, H. Prather Elliott, Jno. T. Evans.

CLEVELAND, OHIO.—Brooks-Norton Co.; capital, \$10,000; to buy, sell and repair freight automobiles. Incorporators: W. K. Stanley, J. W. Brooks, Chas. L. Norton, H. N. Pettibone, R. L. A. Lieghley.

DETROIT, MICH.—Briggs-Detroit Co.; capital, \$200,000; to make automobiles. Incorporators: Jno. A. Boyle, Claude S. Briggs.

DETROIT, MICH.—Weit-Horton Mfg. Co.; capital, \$25,000; to make and sell automobiles.

HANNIBAL, MO.—Long Silent Motor Co.; capital, \$12,000; to make automobiles and engines. Incorporators: Elmer C. Long, Frank R. Tate, Tbeo. Moreno.

KALISPELL, MONT.—Koppang-Jordet Motor Co.; to conduct an automobile agency and garage.

LANSING, MICH.—New Era Motor and Mfg. Co.; capital, \$50,000; to make automobiles. Incorporators: Wm. R. Smith, George Gilmore, John Scheidigger.

HATTIESBURG, MISS.—Southeastern Automobile and Machine Co.; capital, \$50,000; to build automobiles. Incorporators: R. R. Boykin and others.

NEW ORLEANS, LA.—Commercial Truck & Automobile Co.; to make motor cars and trucks. Incorporators: Richard Brook, John D. Edwards.

NEW YORK CITY.—Detmar Auto Sales Co.; capi-

tal, \$20,600; to deal in automobiles. Incorporators: John McLaren, F. B. Knowlton, Edward C. Inderfield.

NEW YORK CITY.—New York Motor Works, Inc.; capital, \$70,000; to make engines. Incorporators: M. L. Rogers, S. E. Robertson, Harry W. Davis.

NEW YORK CITY.—Selden Motor Vehicle Co.; capital, \$500,000; to make motors and machinery. Incorporator: W. A. Albaugh.

SYRACUSE, N. Y.—Julian Motor Co.; capital, \$200,000; to make gasoline engines. Incorporator: Julian S. Brown.

VERONA, PA.—Kowalsky Motor Co.; capital, \$15,000; to sell automobiles. Incorporators: J. G. Criste, W. P. Anderson, J. T. Anderson.

WARRENSVILLE, OHIO.—Bricc Motor Car Co.; capital, \$200,000; to make and sell automobiles. Incorporators: W. P. Kehres, Thomas J. Atkinson, John G. Schultz, E. B. Hecker, J. A. Hecker.

### AUTOMOBILE GARAGES AND ACCESSORIES

AKRON, OHIO.—Electric Rubber Reclaiming Co.; capital, \$200,000. Incorporators: John C. Frank, George H. Ellis, Frank E. Ream, Isaac Laubach, D. F. Felmlly.

AKRON, OHIO.—Miller Rubber Co.; capital increased from \$250,000 to \$500,000.

CHICAGO, ILL.—Garfield Park Automobile Garage; capital, \$5,000. Incorporators: H. E. Halbert, A. F. W. Seibel, Augustus Binswanger.

CHICAGO, ILL.—La Salle Auto Co.; capital, \$25,000; to make accessories. Incorporators: Wm. R. Watson, Geo. W. Curtis, L. Earl Powell.

CHICAGO, ILL.—National Automobile Owners' Alliance; capital, \$50,000; to deal in supplies. Incorporators: G. W. Ford, C. E. Becker, S. C. Miller.

CHICAGO, ILL.—National Spring Tire Co.; capital, \$125,000; to make automobile accessories. Incorporators: Chas. L. Sigman, Jr.; Louis Valence, Chas. H. Jackson.

DECATUR, ILL.—North Main Street Garage; capital, \$10,000. Incorporators: G. G. Council, E. R. Leggett, Chas. T. Council.

MILWAUKEE, WIS.—Auto Starter Co.; to make automobile engine starters. Incorporators: J. D. Babcock, Oscar Fishedick, James T. Drought.

PATERSON, N. J.—Paterson Automobile Trade Association; capital, \$5,000; to hold automobile shows and meetings. Incorporator: Ed. A. Browne.

RAHWAY, N. Y.—Acme Body Co.; capital, \$100,000; to make automobile bodies. Incorporators: Henry A. Grube, Frank B. Gallagher, George L. Freeman.

RICHMOND, VA.—American Adjustable Wheel Co.; capital, \$100,000; to make wheels. Incorporators: R. H. Bruce, Clarence Vaden, J. C. Davis.



P. W. Mulford, of Cincinnati, O., winner of first prize in Winton upkeep contest

# OF INTEREST *to the* INDUSTRY



New factory of the K-W Ignition Company in Cleveland, Ohio.

**CLEVELAND, O.**—The K-W Ignition Co. has moved into its new factory at 2833 Chester avenue. The building is of steel and concrete construction and is fireproof throughout. It is 165 feet long and 75 feet wide and has over 2 acres of floor space.

**RUTLAND, VT.**—The Frenier Automobile Co. is constructing a large addition to its plant in this city.

**BOSTON, MASS.**—The G. E. & H. J. Habich Co. has been incorporated to manufacture automobiles.

**HICKORY, N. C.**—The International Motor Co., of this city, will erect a plant here to manufacture automobiles.

**DETROIT, MICH.**—The Cadillac Motor Car Co. will erect a \$12,000 brick warehouse and a \$10,000 boiler house on Burroughs street.

**NASHVILLE, TENN.**—The Hermitage Motor Co. will erect a plant here for the manufacture of automobiles and motor trucks.

**ATLANTA, GA.**—The Piedmont Auto Manufacturing Co. has been organized here to manufacture automobiles. The company will erect a plant.

**GRAND RAPIDS, MICH.**—The Michigan Suto Joint Company, of this city, expects to begin manufacturing soon at the rate of 300 to 500 joints a week.

**AKRON, O.**—The Goodyear Rubber Co. has declared an annual dividend of 12 per cent. on its common stock, payable January 1 to holders of record December 22.

**FORT WAYNE, IND.**—The Ideal Auto Co., of this city, has increased its capital stock

from \$50,000 to \$100,000. G. H. Hall is president and F. H. Safford is secretary of the company.

**FOND DU LAC, WIS.**—The Dallman & Cooper Supply Company has made a large installation of welding and cutting apparatus manufactured by the Oxy-Acetylene Welding Machine Company of Kansas City.

**NEW ALBANY, IND.**—American Automobile Mfg. Co. is installing additional machinery for the manufacture of motor trucks. Geo. A. Buckley is superintendent of the plant. Trucks will be built in three sizes.

**ANTIGO, WIS.**—The International Hoist Company, which recently absorbed the Pioneer Iron Works, manufacturing gasoline engines and motors, has decided to erect a new plant in 1912 and is now selling \$20,000 worth of treasury stock.

**FREMONT, O.**—The Lauth-Juergens Motor Car Co. has just completed plans for a new building 250 by 60 feet, which is to be used for the assembling and body-building departments of the factory. Another large building will be erected in the spring.

**DETROIT, MICH.**—With the end of the 1912 season still six months away the sales of the Packard Motor Car Co. already equal the entire output for the season of 1911. The increase in sales is largely due to the new six-cylinder model. Sales of Packard trucks for the year 1911 will about double the 1910 output.

**DETROIT, MICH.**—The market for the first week in December bears out indications that the present inactivity in the machine tool trade will continue until after the first of the year. Merchants are hopeful of re-

newed activity in January. The automobile and accessory plants are busy.

**MERRILL, WIS.**—Edward Heldt has been granted letters patent on a rotary expansive steam engine which by a suitable governing device may be made to take live steam through any portion of its revolutions, running the remainder of the revolution on expansion, and capable of having the direction of rotations easily and quickly reversed. The engine has no dead center and hence is capable of starting at any point in its revolution. As a result it has a direct, constant, and uniform torque on the driving shaft. Mr. Heldt is making plans for the manufacture of the engine at Merrill.

**FINDLAY, O.**—Findlay may have a new factory for the manufacture of automobile trucks if plans now before business men are carried through. The truck itself is the invention of Messrs. Ludwig Leitner and M. Weiting, two Findlay men who have been connected with the manufacture of automobiles for the past ten years. The truck invented by the two men is different in all respects from the average truck now on the market. Its chief feature is a chainless drive. It is also characterized by the location of the radiator, which is in the rear of the engine instead of in the extreme front.

**INDIANAPOLIS, IND.**—A new Indianapolis concern is the Bright Carbureter Co., which is to establish a factory at once. The company has been incorporated with an authorized capitalization of \$25,000, which may be increased to \$200,000 with the consent of two-thirds of the stockholders. Those interested in the company are: Ulric Z. Wiley, former judge of the Indiana Supreme Court; Samuel H. Brundage, of the advertising staff of *The Indianapolis News*; Clifford Arrick, broker; Henry S. Rominger, president of the Indianapolis Fancy Grocery Co., and Dr. Clark E. Day.

**TORONTO, ONT.**—The Schacht Motor Car Co. of Canada, Ltd., has been organized by prominent Toronto capitalists to manufacture Schacht cars for the Canadian trade. By an agreement with the United States company the Canadian company has all rights to any patents and improvements which may be obtained by the parent concern. The company has offered to the public 7 per cent. cumulative shares of preferred stock at \$10 a share, each share carrying a 20 per cent. common stock bonus. In all this amounts to \$15,000. Common stock to the value of \$200,000 has also been offered. Orders have been received to keep the factory in full operation for several months to come.

# PATENTS GONE TO ISSUE

**ENGINE**—Internal-combustion motor of the rotary overhead sleeve type.

4. This patent refers to an engine which comprises a cylinder and piston, as well as a casing with a port leading into the cylinder and a second port connected by a passage with the first-mentioned port. One of the ports is located in advance of the other. In the casing a valve plug is mounted revolubly and having a port located in a plane of rotation coinciding with the position of the first-named port. The purpose of this arrangement is to admit periodically an explosive mixture. The valve plug also has an exhaust port in free communication with the atmosphere and at all times totally disconnected from the first-mentioned port.

No. 1,011,601—to Albert Harris Forsythe, Joplin, Mo. Granted, December 12, 1911; filed March 29, 1910.

**VALVE MECHANISM**—Method of operating valves by reciprocating member between cam and valve stem.

1. The mechanism (Fig. 1) comprises a valve and stem, the valve being normally closed by a spring, but connected to a revoluble cam by a reciprocating arm. An adjustable nut is stationed immediately between valve stem and reciprocating mechanism and the nut contains a normally spring-protected member.

No. 1,011,695—to Alexander Winton, Cleveland, Ohio. Granted, December 12, 1911; filed April 29, 1911.

**SAFETY APPLIANCE**—Device for holding wheels in position on axle.

3. The appliance protected by this patent (Fig. 2) comprises a collar formed on an axle, wheels being mounted on either

side of the collar on the axle, and each wheel having a hub. Plates are mounted on the axle and surround the collar, the collar holding the plates against longitudinal movement on the axle. Bearings on the plates support the adjacent ends of the wheel hubs, one bearing being on the inner end of the axle and one being removable, mounted upon the outer end of the axle.

No. 1,011,852—to Ernest Legrand Robertson, Greenville, S. C. Granted, December 12, 1911; filed January 9, 1911.

**EXPLOSION ENGINE**—Rotary sleeve valve motor of the two-stroke cycle type.

2. The engine (Fig. 3) protected by this patent combines the features of a motor cylinder connected with the crankcase as a compression chamber, and having an exhaust passage. The whole flow of incoming and outgoing gas is controlled by the position of one rotary valve.

No. 1,011,748—to Howard E. Coffin, assignor to Chalmers Motor Co., Detroit. Granted, December 12, 1911; filed April 9, 1909.

**FRICTION CLUTCH**—Transmission member of the cone type.

4. This clutch (Fig. 4) comprises a driving shaft and a driven one in alignment with it, as well as a casing with oppositely inclined faces carried by one of the shafts. The faces are in constant relation to one another, and a number of radially movable friction members are in engagement within the casing. A sleeve having wedge faces is keyed to the driven shaft, and means are provided for holding the friction members in engagement with the friction faces of the casing, as well as means for yieldingly

holding the friction members in engagement with the friction faces. The sleeve may be actuated lengthwise of its shaft out of centrifugally actuating contact with movable friction members, whereby they are released from positive engagement with the friction surfaces of the casing.

No. 1,011,834—to Harry W. Nichoalds, Detroit, Mich. Granted, December, 1911; filed October 10, 1910.

**LIQUID ATOMIZER**—A specially shaped nozzle which tears up the particles of a fluid forced through it.

1. This patent refers to a nozzle consisting of a body with an exit communicating with the passage of a disk overlying the body. Over the disk is fitted a tip covering a portion of the passage mentioned and having a conical recess with a discharge port leading from same. The covered portion of the passage enters the recess tangentially.

No. 1,008,119—to Knut M. Dahl, San Francisco, Cal., assignor to Union Iron Works Co., San Francisco, Cal. Granted November 7, 1911; filed June 12, 1911.

**PNEUMATIC JACK**—Device for raising loads by air under pressure.

1. In this jack a cylinder containing a piston is combined with means for conducting a fluid to or from the interior of the cylinder beneath the piston, so as to cause the latter to reciprocate. The means named comprise a hinged rigid tubular handle connected to the cylinder and valved means on the handle for controlling the flow of the fluid under pressure.

No. 1,010,927—to Clarence H. Letcher, San Jose, Cal. Granted December 5, 1911; filed June 26, 1911.

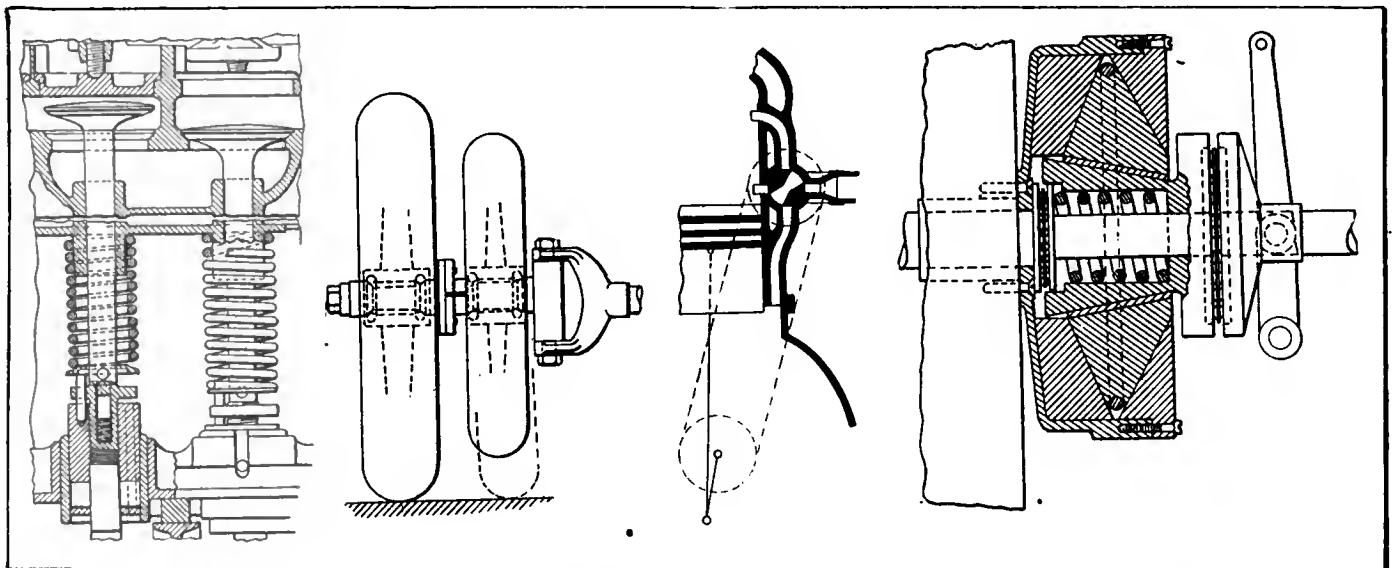

Fig. 1—Winton valve mechanism    Fig. 2—Robertson safety appliance    Fig. 3—Coffin explosion engine    Fig. 4—Nichoalds friction clutch

# Newest Ideas Among the Accessories

## Vanometer Gasoline Gauge

**T**HE Vanometer shown in Fig. 1 is a gasoline gauge of extreme simplicity of construction, as it has hardly any mechanical parts at all. It operates on an application of the principle of communicating vessels, the installation of the instrument and its connection with the gasoline tank being clearly depicted in Fig. 3.

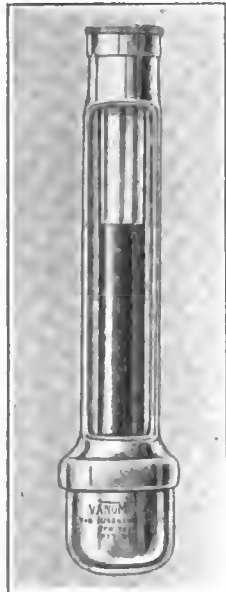

Fig. 1—Vanometer

The Vanometer consists of a U glass tube, 1-2 inch in diameter and filled with a red liquid of a certain specific gravity and chemical composition. The top of the one leg of the U tube, which is contained in a nickel casing, has an opening, so that the air above the liquid is in communication with the outer

air. The other leg of the U tube is just high enough to hold the liquid when it is on the same level in both legs of the tube. This lower leg is connected to the empty gasoline tank by a gas tube after the Vanometer has been installed on the dashboard in any desirable position. In installing the gauge the level at which it is placed does not matter.

The Vanometer being in place on the dash, a 1-4-inch hole is made in the top of the gasoline tank and a coiled tube is put through the opening so as to have its lower end almost in touch with the bottom of the tank, and the pipe is connected to the branch of the Vanometer. After this the gasoline is poured in the tank, until the red fluid in the nickel-encased glass tube rises to the top of the latter, which indicates that the tank is full. This holds good for any shape and size of gasoline tank, if the Vanometer has been installed while the tank was empty. The length of the connecting member of the U tube is such that the highest gasoline level corresponds to the highest possible level in the instrument. As the gasoline is being consumed by the engine cylinders the air in the gas tube travels toward the tank, the gasoline falls to the bottom of the tank and the red liquid falls to zero,

while the half-height of level in the tube corresponds to a half-filled gasoline tank, and so forth at various levels.

The Vanometer operates equally with gravity or pressure feed systems, as only the level in the tank influences that in the indicator tube. It is made by the Van Auken Indicator Co., 123 Liberty street, New York City, in sizes for automobile tanks as well as for garage storage tanks.

## Single Button Switch

The button switch shown in Fig. 2 is unique in that it has but a single button for turning the lights on and off. In operation the button is first pressed in to turn on the lights, after which it immediately returns to its normal position. A second push on the button, after which it returns to the normal location, and the lights are out. The maker, Joseph F. O'Brien Co., 61 Park Place, New York, claims that the single button switch was perfect over a test of 15,000 pushes, which is more than practice requires.

The switch is easily installed, requiring only one hole to be bored in its round body.

ized. Its friction surface gives it additional holding strength and it is made flexible on the sides and ends so as not to chafe the inner tube. The patch is the product of the Traver Blowout Patch Co., 1779 Broadway, New York City.

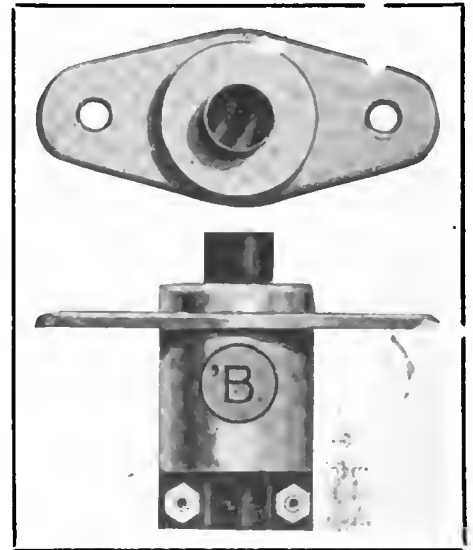

Fig. 2—Single button switch

## A. A. Gas Lighter

The Auto Appliance Mfg. Co., of 18 Buchtel avenue, Akron, O., has begun to manufacture and sell a device producing a high-tension jump-spark across a gap located above the acetylene headlight burner. The system combines this igniter with the acetylene piping system, in that the flow of gas is controlled by the handle of a needle valve on the dash. One terminal of the battery is connected to the coil and the other to the piping system which thus closes the circuit as soon as the gas is turned on.

## Traver Patent Blowout Patch

This patch fits the inside of the shoe and keeps in position as long as the shoe remains in service, without being cemented or strapped, laced or bolted, as it is equipped with a sort of metal bead by means of which it locks on the rim.

The Traver patch is made of highly compressed Sea Island cotton and covered with high-grade rubber and hand-made throughout. It is moulded or cured, so that the fabric is neither crowded nor overvulcan-

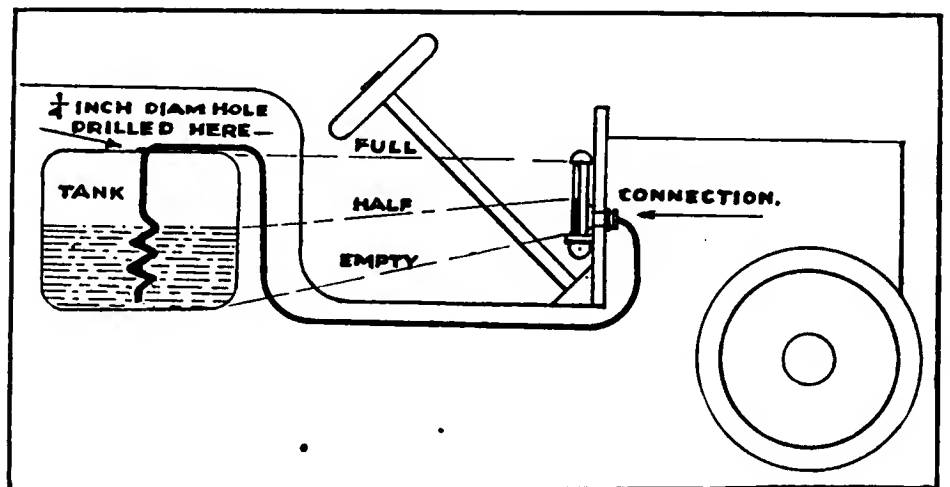

Fig. 3—Method of installing the Vanometer on the car



# THE AUTOMOBILE

## Garden of Allah as Touring Field



TOURISTS IN ALGERIA TRAVELING ALONG THE BED OF A CREEK AT BISKRA

**F**OREIGN touring *en motor* is shrouded with more or less glamour and despite the fact that each year finds a large increase in the number of American tourists who seek foreign fields for pleasure and recreation, a material section of whom are automobilists, there is still sufficient novelty about a foreign trip to make it very attractive.

The show places of Europe are become beaten pathways for American automobile parties and as Asia and South America are still somewhat too chaotic from a road viewpoint to make good touring fields, the attention of prospective visitors is naturally directed toward Northern Africa after the splendors of Europe have been exhausted.

At the present moment the war being carried on by Italian troops in Tripoli has centered the eyes of the world on the Mediterranean coast of Africa. Egypt has long been familiar with the automobile. Tripoli has been too unsettled politically

to attract tourists with their cars to any great extent and the same might be said for Morocco, on the Atlantic coast.

But Algeria, the French sphere of influence in northern Africa, presents a more attractive outlook for the automobilist who desires to tread more or less unbeaten paths.

The city of Algiers, capital of the department, is situated on the sea coast in about the same latitude as Washington, D. C., St. Louis, Mo., and San Francisco, Cal. The country extends southward in three great upward steps until human boundary lines are lost in the shifting, mysterious sands of the Sahara.

The Atlas mountains run parallel with the coast from Tunis to the eastern boundary of Morocco. These mountains, which are not particularly lofty nor impressive from the modern viewpoint, have been famous since mythological times because they were likened to the giant Atlas, who was said to support the world on his shoulders.

South from the mountains lie a series of plains call sebkhas, which are covered with vegetation similar in character to the plains of Idaho. Numerous salt lakes are sprinkled here and there over the sebkhas. This section is bounded on the south by another range of mountains and behind the mountains is the Sahara.

The northern valleys are fertile and under the name of the Tell, once constituted a factor in supplying grain to various European countries, especially Italy. Algeria has a mean temperature of 63 deg., which makes it excessively hot in summer, but delightful for American tourists from November to April.

The history of Algeria explains why there are probably 1,000 miles of excellent automobile highway in the country. The Moors, Arabs, Turks and negroes never built a road except

Navy, destroyed the sea power of Algeria in battle and crushed the institution of piracy, causing the release of 1,200 European and American slaves who had been taken in the various incursions of the piratical deys.

In 1830 the Turkish power in Algeria was broken and the Turks expelled by the invading French. For 40 years after the initial occupation, the French were constantly embroiled, occasionally defeated by the Arab chieftains and always more or less tangled up with war, graft and mismanagement. But since 1870 the situation in Algeria has become more stable and today, while the country is much less traveled than Egypt, it is practically as safe as France itself from the standpoint of the automobile tourist and still sufficiently unknown to the world generally to prove attractive.



2—Departure of a caravan of camels escorted by an automobile

3—All the natives come out to witness the arrival of the tourists

4—Ancient and modern means of desert travel exemplified

under military compulsion, and as military exigencies along the lines of road building were never pressing during the control of the country by either of the elements mentioned, the present road system may be attributed almost *in toto* to the French.

At the beginning of the Nineteenth century Algeria was a Turkish dependency. It was governed by a combination composed of a native dey and a Turkish pasha. Being somewhat isolated from the fountainhead of the Ottoman government, the dey of Algiers was able to strain the bonds sufficiently to allow a system of piracy to become the chief industry of his subjects. All nations either paid tribute to the corsairs or suffered robbery at sea. Time after time punitive expeditions were directed against the practices of the deys but nothing decisive was accomplished until Commodore Decatur, of the United States

The history of the roadmaking in Algeria is closely associated with the French military occupation. The first expeditions were in the nature of landing parties backed by the fleet and the soldiers stuck closely to the garrisoned cities. When it became necessary to repel attack the sorties were made by flying columns and the distances covered were comparatively unimportant.

The history of nearly all of the French expeditions proved to be similar until a different plan was devised. The French generals would gain victory after victory against the elusive and well-mounted irregular cavalry and once in about 10 years an army division would be wiped out by the Algerians. It has been estimated that the French occupation cost the lives of 150,000 men and \$800,000,000 up to 1870.

But a few years before that date an improved plan of occupation had been devised and instead of moving against the shadowy Arabs with flying columns, the Europeans gradually forced them back by main strength, establishing civil governments in the places within their lines, building military roads in their rear and step by step forcing the natives into the hills and beyond. This plan proved effective and in a surprisingly short space of time the leaders of the insurrection were pushed out into the Sahara and there was peace in Algeria.

The uninhabitable character of the desert, save here and there where springs and wells cause an oasis to bloom amid the somber sand, marks the limits of civilization and while practically all the country included in the classification sebkhas, can be made exceedingly productive, the really productive section at

There are two good ways to reach Setif, which is a divisional point on the route from Algiers to Biskra. The first of these is to take the coast road through Tizi Ouzon to Bougie and then go south through Kerratta, reaching Setif from the north.

The other way is more spectacular and interesting. The coast road is very similar to the average well-kept French highway, although it is set in a picture of vastly more interest than is presented by the usual French country side. But the alternate road that may be used in reaching Setif is interesting in every stage. The first stretch is identical with the coast road, but branches off to the south about 30 miles from Algiers. The coast road continues east to Tizi Ouzon, about 60 miles, the last 15 of which are rather winding and encompassing a number of sharp grades.



5—The natives were astonished at the appearance of the tourists

6—There were a few formalities necessary outside of Biskra's walls

7 The natives and their families insisted upon being given a ride

present is represented by the same valleys in the Tell that have been granaries since the time man first required grain.

An automobile tour through the Tell, while interesting and in a certain sense unusual, is not sufficiently so to make the journey worth while. But if the tourist wishes to enjoy something really unique he may tour from the city of Algiers to Biskra, an oasis in the sebkhas, less than 200 miles in a direct line, but by the military roads the distance is nearer 450 miles.

Leaving Algiers, the road east, following the sea coast, is magnificent for 50 miles. It was once the main military artery in the French scheme of occupation and traverses a country that resembles the soil and general appearance of the north Georgia mountains and in January is not unlike that portion of the United States in September or October.

The country traversed is devoted to grape culture to a large extent and is delightfully attractive to the eye and senses.

Tizi Ouzon makes a good luncheon stop for the first day and the facilities to be found there are ample. The afternoon run is rather long, but the road surface is so perfect that little difficulty will be experienced in getting to Bougie in ample time for dinner. The afternoon run from Tizi Ouzon is largely up grade, with a few steep hills to climb and from the summits of these successive ranges, glimpses of the blue Mediterranean can be caught. For one long stretch before reaching Bougie the road ascends a 3 per cent. grade so evenly that it is difficult to tell while running whether the car is going up or coming down.

Bougie is an ancient seaport and has a most interesting native



General view of the oasis of Biskra from the opposite side of the river

quarter which will repay investigation by the tourist. Gasoline costs 33 cents a gallon at Algiers and gradually increases the further one gets away from the railroads. The roads are rather narrow, ranging from 10 to 14 feet. Like the best military roads, they were constructed with small regard for labor. There are some spots where they wind tortuously through canons, but as a general principle the engineers constructed them with the idea of making the passage of artillery as easy as possible. This accounts for the long, gentle and almost inappreciable grades such as the one entering Bougie.

All along the coast from Algiers to Bougie the road leads through vineyards which have taken the place of grain fields to a considerable extent. The grapes of Algeria have a world-wide reputation and are in demand wherever they may be shipped.

Let no tourist undertake this journey without a camera and plenty of plates and films, for each hour of the way will afford opportunity to take pictures of extraordinary interest and beauty.

There will be no trouble experienced in missing roads in northern Algeria. In the first place the roads themselves are infrequent and the main highways cannot be mistaken. The occasional cross-roads are usually marked and as a consequence there is little probability of losing the road. The hotels are surprisingly good along the coast.

The next stage of the route is to the ancient town of Setif. This place lies a little east of south from Bougie and is located about the center of the fertile interior plateau in the northern section of the country.

The roads are similar to those encountered in the run from Algiers, but as they ascend toward the foothills of the Atlas mountains they are narrow and winding.

The run from Setif to Biskra may be made in one day, but it is advisable to cut the itinerary in two so as to take in the city of Timgad, which was used for centuries as the headquarters of the desert hordes which made periodic descents upon the constituted authorities, native, Turkish and French.

The tourists must retrace their course along the road to Lambese and Batna before regaining the ascending trail across the Atlas range. In this particular section the mountains are called the Aures. East of the pass El Kantara through which the travelers go, the craggy steeps tower into the sky and set up a barrier that is entirely impassable to automobiles, but the road to be followed is good clear to the summit. It winds southwestward around the foothills and then enters the pass of El Kantara, a canon, the walls of which almost shut out the daylight they are so high and stand so close together. This was the pass once captured by the Romans that was held for 300

years by one small tribe of Kabyles against the assaults of all other tribes and the military operations of the Turks and Europeans.

On the northern side of the pass the climate is laden with the adequate moisture from the breath of the sea. The hills are covered with verdure; the vines hang heavy with luscious fruit and the fields bear luxuriantly. But as soon as the summit is passed and the travelers emerge on the south side of the pass the whole scene is metamorphosed. The same transition has taken place that is so noticeable in crossing the Cascade mountains in Washington and Oregon. At Portland or Seattle the climate is moist and the natural verdure is almost sub-tropical, but east of the Cascades it is as dry as the Sahara, the reason for this marked difference in climate between sections that are adjacent is the same in Africa as it is in the United States. The rocky wall of the Atlas mountains serves as a barrier for the sea breezes. The cold peaks precipitate the moisture when the winds from the Mediterranean touch them, but the rain falls on the northern slope and whatever portion of the north wind succeeds in getting over the range has been stripped of its life-giving moisture.

Thus the country south of the pass looks like eastern Oregon. Sagebrush, or something closely resembling that plant; greasewood and heather are about the limits of vegetation. The air is dry and the climate has all the characteristics of the desert.

But there is one material difference between this section of Algeria and that of say, southern Arizona. The geology of the country is such that springs are frequent, even in the desert. The bed rock lies close to the surface and where minor faults occur the water flows out of the ground.

The marvel of nature is seen where this happens. On all sides the yellow barren sand gives no promise of life, but where these little springs flow forth the desert blossoms into an oasis. Date palms, gracefully nodding in the soft breeze, are typical of the oasis and wherever the water flows, the sand produces abundant vegetation. Cattle, camels, goats, sheep and horses have thriven for centuries on the fodder provided by the desert springs and clear to the edge of the great, arid Sahara, the oases support a large permanent population.

Oases range in size from an acre of isolated palms, sufficient in size to support a single family, to garden spots 12 or 15 miles in diameter, entirely surrounded by dry sand and having no apparent inlet or outlet for the spring-fed ponds and lakes with which its surface is dotted.

The city of Biskra, with its considerable population and its array of shining white buildings, is situated in the midst of such an oasis, which is reported to hold 150,000 palm trees.

Just after leaving the mouth of the pass a new bridge has been constructed to carry the road across a deep canon. This bridge recently has been finished and is a vast improvement over the former method of covering this section of the road.

The accompanying pictures indicate something of living conditions as they are found at Biskra. The oasis is extensive and besides the Kabyles, Turks, negroes and Bedouins there are many Europeans. Some fine residences have been erected by French noblemen at Biskra, which are used for homes from 7 to 9 months in the year.

The military road system of Algeria comprehends two complete parallel lines of road. The first extends generally along the coast from Oran to Tunis. The second skirts the hills from 30 to 40 miles back from the coast. Between these two lines there are cross-roads at irregular intervals and a third line of parallel road has been partially finished.

Extending south from the main sea-ports are roads that penetrate the second mountain range and in the case of the road by which Biskra is reached, the road continues out into the desert as far as Tougourt. This is the same road that starts south from Bougie and the large city of Constantine. The longest southerly road leading directly from Algiers passes through Chiffa and Medea; climbs the mountains through a gorgeous pass and strikes south through Boghari and El

Krachem to Lagouat and finds its terminus deep in the Sahara at Ghardaia. Another road from Algiers runs through Arba and Aumale to Bou-Saada, a small place in the northern foothills of the Oulad Nail.

A tour of Algeria may well occupy a whole winter but the more interesting points may be covered in from 4 to 6 weeks. There are several ways of reaching Algiers from the United States, but all of them require transshipment of the car. Steamer lines from the French Atlantic and Mediterranean ports are probably more direct than others. The cost of shipment is in the neighborhood of \$125 from New York. Gasoline at its cheapest is twice as dear as it is in the United States and good oil is scarce and costly. If the party contemplates going away from the regular automobile routes, provision had better be made for supplies of fuel and oil, as it would be very annoying, and perhaps dangerous to run out of them in the desert.

A party of tourists who have been making the rounds of Algeria, requiring a period of six months to do so, give some interesting details regarding automobile travel there. The cost for shipping a motor-car from Southampton, England, to Algiers is \$70, besides \$5 for unloading at Algiers. The Algiers shipping authorities extend satisfactory courtesies; although the reliability of the Arab assistants is not by any means certain, these not exercising the least concern over missing tools or seawater in the radiator. As a rule, the hotel accommodations are excellent. Signs are displayed notifying automobilists that garages are maintained, and also that this or that particular hotel is recommended by The Automobile Club of France. It is not difficult to obtain petrol in any village. The roads of southern Algeria are very carefully made, a great roller, drawn by many teams of mules or horses being used. The quality of the work compares favorably with that which is done by a steam-roller.

## A Budget of News From Australia

SYDNEY, N. S. W., Nov. 26—Since February of this year trade has grown to a very considerable extent, so much so that those who profess to be any authority predict that a crisis is near at hand and many agents, especially those recently started, may go out of business. As was said nearly a year ago, every leading European car had an agent here and others starting had to look to America for their lines, and the result has been that almost every car advertised in THE AUTOMOBILE is now represented on this market as well as several other makes, and our population is only 4,000,000 and cars costing much more here than abroad, it is difficult for agents to live up to their contract numbers, and in the end it means someone is going to lose a lot of money, and also there is going to be a large number of cars thrown on the market, and having this end in view, some of the older agents are intending to cut the prices and bring this crisis about early and avoid as much as possible the glutting of the market.

Second-hand cars are a bad proposition in this country and an illustration was given when the General Motor Co., Ltd., went into liquidation on account of serious customs frauds perpetrated by the managing director, who is now undergoing a term of imprisonment for the same. At the liquidation sale a large number of second-hand cars were offered, but although the sale was well advertised and some of the cars were well known, and also of well-known makes, the prices realized were terribly low, and brought only 60 per cent. of expert's valuation, while on the other hand new cars brought within 3 per cent. of the list price. These cars were the Renault and the British Wolseley.

Although the high-priced European car has a good steady market, American cars also have a good market and numbers of Hupmobiles, Fords, Overlands, Chalmers and Cadillacs are to be seen running along the streets, whilst other makes which do not have such pushing agents are also to be seen.

In speaking of pushing agents it might be mentioned that agents of the Hupmobile, Overland and the Hudson were doing a good trade in high-priced British and French cars previous to their taking up any American agency, but since taking American cars they are advertising and pushing the American cars for all they are worth and never mention their European cars.

There is a good trade to be secured in this country by the first maker who introduces a good light delivery van to carry loads up to about 1000 pounds, and such vehicle must be reliable and low cost to purchase, not exceeding \$650 in America. As fuel is a costly item here, an economical carbureter is necessary. Air cooled engines will not have any demand, but the car which has solid tires, if only on the back wheels, will also assist the selling. The type of body does not matter, in fact no body at

all is the best, as most users are sure to have a particular idea of their own as regards body work, and not only that, the duty on body work is heavy, 30 per cent. ad valorem, whilst the chassis is only dutiable at 5 per cent.

To give an idea of what is required in this line, the Greater J. D. Williams Amusement Company, which company is the leading moving picture enterprise in this country, is using a Brush car fitted up to carry a few hundredweight.

There is also another line that could be pushed in this country and that is stationary engines suitable for farm work. Most farmers are using the expensive English oil engines and on account of their heavy weight they render themselves a little unsuitable for shifting about, while a light gasoline engine will be more suitable, and already there are several lines on the market. Apart from those sold by the International Harvester Company, the Ferro engine is doing well, but there is no reason why lines of this description should not take the entire place of the heavy and clumsy engine.

Sundries of American make are slow in making their appearance in spite of the advice given in THE AUTOMOBILE some 6 months ago, and what is really required is a good distributing house to introduce useful lines, and have them properly represented to realize a good return on the investment.



The camels contemplate their successor with placid mien



## Industrial News by Mail and Wire

**S**OUTH BEND, Dec. 26.—J. M. Studebaker, Sr., who for 54 years has been vice-president or president of the Studebaker Brothers Manufacturing Company, has resigned to become chairman of the board of directors of the Studebaker corporation, which was organized in the latter part of February, with a capital of \$45,000,000.

Frederick S. Fish was elected president of the corporation, Clement Studebaker, Jr., was chosen vice-president and chairman of the executive committee; A. E. Erskine, treasurer; Frederick P. Delafield, of New York, special counsel, and Scott Brown, of this city, general counsel and secretary.

J. N. Gunn, of New York, was appointed general manager of the corporation, co-ordinating the administration of the automobile division, the horse-drawn vehicle division and the harness division of the business. The other officers of the corporation remain as before.

### News of Detroit Factories

**DETROIT, Mich., Dec. 26.**—C. C. Hildebrand, assistant general manager of the Chalmers Motor Company, who has just returned from a tour among the Chalmers dealers that embraced the entire country, is most enthusiastic over the outlook for the coming year and is quite satisfied with present conditions for the season of the year.

"I have never known the prospects for the industry to be any better," he said. "In all parts of the country Chalmers dealers report business far ahead of last year and indications for the spring are certainly very encouraging. A great many of our dealers have already sold from 80 to 100 per cent. of their 1912 allotment, and the demand for additional cars is general. I was especially surprised over the business being done in the South, and when the South gets better roads it is going to be a great field. And down in Cuba the motor car is becoming more popular every day. The island is beginning to literally swarm with them. This has been the biggest December in the history of the Chalmers Co. Our sales for the month to date are more than 250 cars ahead of last December."

Employees of the Chalmers factory had material evidence of the company's prosperity in the form of an extra week's pay, which was handed them Friday noon as a Christmas remembrance. Every factory hand who had been in the company's employ for six months or more and every member of the office force who had been with the concern a year or longer was a beneficiary in this distribution of Yuletide cheer.

The Hudson Motor Car Co. also took a hand in the Christmas giving, providing 17 poor families with substantial dinners today and all the clothing that was needed.

The Studebaker Corporation has come into actual possession of the factory at Port Huron, now known as plant No. 2, where for the past five years rear axles for the E-M-F "30" and Flanders "20" cars have been manufactured, together with eleven lots. The property was originally donated to the Northern Motor Car Co., which was one of the companies that were merged to form the E-M-F, on the condition that it be used for the manufacture of automobiles or automobile parts. When the plant had been occupied five years the Port Huron Chamber of Commerce was to turn over the deeds, provided the firm occupying it had paid out \$200,000 in wages. The time limit expired several days ago, and the company having fulfilled the other conditions there was nothing for the Chamber of Commerce to do but turn over the deeds, which it did cheerfully. The plant now employs 500 men and has been one of the main industries of the Tunnel City for some time.

The Argo electric brougham, manufactured in Saginaw, made its first appearance in Detroit Saturday and attracted no little attention. It is a low-hung car with sweeping lines. It has a steering wheel instead of a lever, a direct herringbone gear drive, chainless and noiseless, and the Argo combined speed control and brake. George Waller, sales manager for the Argo, is in the city to arrange for an agency here.

### Case Company to Change Form of Name

**RACINE, Wis., Dec. 26.**—It is reported that the J. I. Case Threshing Machine Co., of Racine, Wis., the largest industry of its kind in the world, and for some time manufacturing motor cars, having purchased the Pierce Motor Co., of Racine, will reorganize immediately after January 1, in order to greatly extend the scope of its activities.

The name is to be changed to the J. I. Case Co., and new lines of machinery and implements will be produced. It is reported that the extension of activities will include the entrance into the motor truck and farm tractor field.

### Alco Truck as Aid to Santa Claus

A 3-ton Alco truck, equipped with solid tires, has been engaged this week in one of the most trying endurance tests that ever has been attempted in demonstrating the enormous capacity for work of a commercial vehicle.

The truck was placed in service Monday to aid the Adams Express Company in handling its Christmas business. It ran night and day for 125 hours. The crew of drivers and helpers was changed every few hours.

In one stretch of 24 hours the truck carried 120,000 pounds of goods, making twenty trips.

### Franklin to Continue Some Branches

**SYRACUSE, N. Y., Dec. 26.**—Contrary to the announcement made in certain sections that the Franklin company was about to abandon all its extensive system of branch houses, following the changing of the form of agency in New York and elsewhere, the company declares that the intention is to maintain such branch houses as those in Chicago, San Francisco and in other centers of general distribution.

The reason for the abandonment of the branch houses in New York, Boston and several other Eastern cities is that under the present selling plan of the company the necessity for fully equipped branches has ceased to exist and the business can be handled with more celerity from the factory itself.

### Hewitt Heads New Truck Company

Edward R. Hewitt has been elected president of the recently incorporated Hewitt Motor Company, and R. C. Gildersleeve, formerly general manager of the truck department of the Metzger Motor Car Company, has been elected secretary and treasurer.

The company was incorporated for \$1,000,000 to extend the manufacture of the Hewitt truck. This car has been made by the Metzger company since about two years ago and is used to a considerable extent in New York for handling coal and other bulky freight. The new company has secured the Metzger interests in the truck and is installing a factory in a six-story concrete building at West End avenue and Sixty-fourth street.

According to announcement the company plans to make a specialty of its service department, which will be coincident with the factory. Mr. Hewitt is now engaged in purchasing machinery which will be installed next month. The directors of the company include M. F. Burns, of Burns Bros., coal operators of this city, the largest users of Hewitt trucks in New York; E. C. Converse, William E. Corey, E. R. Hewitt and Ambrose Monel.

### Hope for Champion Wagon Company

In the United States District Court of Northern New York an order has been entered recently appointing Theodore D. Gere and Fred C. Hill, of Owego, N. Y., as receivers for the Champion Wagon Company. Mr. Gere is general manager of the company.

The company has been in financial difficulties for some time and suspended manufacturing operations last month. An immediate effort was made to compound the debts of the company and to keep it running until a plan for solvent reorganization could be discovered and adopted. In an official announcement to the creditors and stockholders Mr. Gere states that the general creditors are willing to discount their claims fifty per cent. in case a reorganization can be effected.

A meeting of the bondholders has been called and the hope is expressed that the receivership will be only temporary.

### Klaxon Enjoins Rubber Company

The Lovell-McConnell Manufacturing Company of Newark, N. J., recently brought suit in the United States Circuit Court for the Southern District of New York for alleged infringement of the basic Klaxon patents, 923,048, 923,049 and 923,122, by Henry Phillips.

Mr. Phillips conducts his business under the name of the H. Phillips Rubber Works at 1931 Broadway, New York City. Mr. Phillips, according to the complaint, infringed those patents

by cutting prices and otherwise violating the terms of the license set forth on the tags, sealed to every Klaxon and Klaxonet before it is put upon the market. The case came before Judge Ward for hearing on motion, and a preliminary injunction was granted.

### Duryea Sells Out; To Form New Company

SAGINAW, MICH., Dec. 26—C. E. Duryea, who recently resigned from the presidency of the Duryea Automobile Company, has announced that he and others will form a new company in the near future to manufacture pleasure cars exclusively. Mr. Duryea is seeking a suitable site for the manufacturing plant.

The settlement of the difficulty that had arisen between Mr. Duryea and the old company was brought about by the sale of his stock to C. C. Brooks. The concern under the direction of F. G. Palmerton will continue to manufacture commercial trucks.

### Bennett Promoted in Overland

TOLEDO, OHIO, Dec. 27—George W. Bennett has been appointed vice-president of the Willys-Overland Company, the promotion from the position of sales manager to a berth next to president John N. Willys being made Dec. 20. Mr. Bennett is a veteran in the motor industry and for years was sales manager for the Rambler. Then he joined the Knox forces and after a brief stay with that concern he assumed the managership of the New York White branch, from which position he went to the Overland company.

### Penn Unit Machinery Sold to Junk Men

ALLENTOWN, PA., Dec. 26—The plant of the Penn Unit Automobile Company has been sold piecemeal, realizing \$45,000. It is said that the property cost upward of \$200,000. Most of the machinery was bought in by junk dealers and the real estate went to T. E. Ritter.

## Touring Club Plans Southern Tours

TO MEET the increasing demand for the latest and most accurate road data in the Southern States, a path-finding trip under the direction of the Touring Club of America will start within a fortnight from Augusta, Ga., going to Nashville by way of Atlanta and Chattanooga. This trip, which will cover upward of 600 miles, will be made under the direction of the Southern Vice-President, D. D. Armstrong, of Atlanta.

An interesting feature of this scouting trip will be the charting of one of the most delightful Southern routes, which will be taken by a large party of motorists and good roads enthusiasts early in February to attend the automobile show to be held in Atlanta, Ga., in the Auditorium-Armory from February 10 to 17 under the auspices of the Atlanta Automobile and Accessory Association. Parties are now being formed in many of the cities along the route and the forthcoming tour, as a preliminary to the South's big automobile exposition, will be the greatest demonstration that has yet been given of the increasing interest throughout the South in automobile progress and the need of improved highways.

This path-finding run, with which the Touring Club of America will inaugurate the campaign of 1912, is but one of a series of similar road scouting trips through the South and other parts of the country which will be made within the next few months to secure road data for the Automobile Blue Book, the official guide of the Touring Club of America. The Augusta to Nashville tour will greatly enlarge the road and touring material acquired by the Touring Club.

The road from Nashville to Chattanooga with the exception

of one short stretch, which will be improved before the Atlanta Automobile Show tour starts, is in very good condition. The Chambers of Commerce, Boards of Trade and civic organizations along the route are showing a keen interest in this good roads demonstration and ample assistance toward improving many sections of the highway has been promised.

Mr. Armstrong will have the co-operation of J. M. Waite, one of the leading good roads boosters of Nashville, and Houston Harper, of Chattanooga, manager of the Touring Club's branch in that city, who will have general charge of the preliminary work in their respective cities and will make arrangements to receive and properly entertain the motorists traveling to the Atlanta show early in February.

It is not improbable, providing weather conditions will permit and the roads are found to be available for touring, that the scouting party instead of terminating the trip at Nashville will continue to Memphis and New Orleans by the way of Birmingham, Meridian and Jackson.

A more desirable route to New Orleans has been sought by many motorists as that city is visited annually by thousands of travelers, especially during the Mardi Gras festivities. It has even been suggested by several prominent automobilists and good roads advocates that a popular tour to New Orleans under the auspices of the Touring Club might be organized for that novel and world-renowned celebration.

From New Orleans the Touring Club's representatives will return to Atlanta, visiting Mobile, Montgomery, Ala., Columbus and Macon, Ga.

# News of Shows, National and Local

SOME 330 men representing two score trades were put to work in Madison Square Garden, Thursday, for the Twelfth National Automobile Show, which opens Saturday night, January 6.

W. W. Knowles, who is in charge of the work of decorating the Garden, has groups of men at work in all parts of the big amphitheater and they are to labor night and day up to the opening hour of the show. Gangs of iron-workers are now installing the big girders which are to support galleries.

Practically all of the sculptor work and the scenic paintings which will be used in the decorative settings for the exhibits are now ready to be set in place. Carpenters and wood workers are engaged in the construction work of the booths and ornate wood effects.

The arena floor was put down several weeks ago. In a vacant office building in this city more than 200 women are sewing together the carpet which is to be used to cover the space of the exhibits. Twenty carloads of furniture which is to be placed in the booths of the exhibitors has been delivered at the Garden. Two monster elevators which are to be used to hoist the cars and accessories to the balconies will be installed in a few days.

Last week, while the roosters were crowing on the main floor during the poultry show, men were at work in the basement cleaning and painting and covering the walls and pillars with old-gold paper. The basement, with its bodega set in Southern California scenery, is practically finished.

The exhibition hall, which is to represent a realistic outdoor Spanish garden, is now receiving the attention of the decorators, as is also the Japanese cherry garden, which will be the theme of decoration in the concert hall.

The Garden will be opened daily to the general public from 11 a. m. to 11 p. m. During Part I the garden will be open from noon, Friday, January 5, to 6 p. m., January 6, for the installation of the exhibits, at which hour these will be in place. No exhibits or goods will be admitted into the building after 6 p. m., Saturday, January 6. All goods will be received and shipped from the Garden at the corner of Twenty-seventh street and Fourth avenue. No goods will be permitted to be brought into or removed from the building from any other entrance. A clerk will be stationed at the entrance of Twenty-seventh street and Fourth avenue to check in all receipts of goods.

## Grand Central Palace Show Final Plans

While it has been customary for the promoters of automobile shows to expend thousands of dollars on decorative features, the coming event at the Grand Central Palace, which opens to the public at 8 o'clock on the evening of January 10, will not be one whit behind anything ever attempted in this city in the line of beautiful setting.

To persons accustomed to the gloom of the old building at Forty-fourth street the new structure, which is in every way deserving of the name given it, will prove a revelation. It is one of the most beautiful things, from an architectural viewpoint, in New York. Its massive columns, beautiful marble trimmings, hard maple floors and accompanying splendor are probably of higher class than have ever been attempted in a building of the size and designed for the same purposes.

The management of the coming show, attended by the best scenic artists of the city, spent a great many days figuring on the scheme of decoration and equipment, agreeing after every

session that to attempt anything of the sort would be akin to painting the lily. As a result of these deliberations there will be placed in the Palace nothing of the gaudy material usually designed to cover the unsightly spots of public buildings—nothing, in short, which can be properly described as anything short of the finest forms of artistic production.

Mural paintings will predominate. They will be used liberally, but rather because the public expects this sort of thing in connection with an automobile show than because it is a necessity. The moment one enters the building the effect will be that of an Italian garden. The main floor is approached by means of a flight of marble steps, 60 feet in width, decorated with brass railings and trimmings and ornamented for the occasion with bronze emblems, typical of the progress of the industry and growing palms of great height and size. On the center of the floor, where the exhibition spaces are large and will contain some of the finest productions of the industry, there will be absolutely nothing in the form of decoration, except the necessary signs, on which a great deal of care has been exercised, and the floor covering, which is of wood carpet, so made and laid that it may be cleaned and polished every night after the show has closed.

There will be none but passenger cars in these sections. The scheme of decoration commences at the walls. Every window is to be draped, to exclude the glare of light inseparable from a building so liberally furnished with windows. The space between the windows, extending to the ceiling, will be entirely hidden by paintings by one of the city's best scenic studios.

Some of these paintings are of mammoth size, as, for example, a canvas 60 x 50 feet, depicting the effect on a herd of centaurs of the appearance on the scene of a modern motor car. This work of art will perhaps be the most interesting study of the collection. These spaces will be occupied almost exclusively by passenger cars, though there will be a couple of the more important exhibits of commercial vehicles also, and care has been exercised to harmonize the color scheme with the bodies of the cars to be shown.

The second floor has been similarly treated, so far as walls are concerned, but around the front of the balcony will be placed fifty or more marble vases filled with poinsettias and green foliage. The center of the third floor is separated from the main building by trellis work of great size, which will be completely covered by foliage and flowers, the whole presenting a scene of rare beauty, viewed from any direction, but especially from the main entrance and lower floors.

The size of the Palace makes it particularly desirable for the holding of an exhibition of the kind. It has a greater amount of exhibition space than any other show building in America. The exhibits at the coming show will cover 138,000 square feet of space.

The noisy demonstration of horns and other alarms which have characterized some of the automobile shows of the past will be absent at the show. The management has made a rule that no horn will be permitted to enter until its reed has been removed and that no other form of alarm may enter the building until it has been so altered that no sound can be emitted by it. Exhibitors have shown a disposition to obey the rule, regardless of any further action by the management, by written assurances that they will follow the rule in letter and spirit.

One of the difficulties heretofore experienced by automobile show promoters has been keeping the floors of their buildings free from dirt. The enormous crowds constantly walking over the carpets have left indelible stains which have been unsightly.

This will be overcome at the show at the Grand Central Palace. A floor covering is to be used, consisting largely of wood painted to suit the coloring of the cars, which will be washed and repainted after the close of the show each night, so that the floor will at all time be inviting and in keeping with the magnificent details of the remainder of the building.

For the first time in 7 years the people of New York and the thousands who come to New York for the annual automobile shows will be able to examine all of the cars of importance made in this country the same week. Heretofore trade rivalry made this impossible. The show at the Grand Central Palace has for several years been held a week ahead of the Garden show in the hope of getting first attention at the hands of the public and the press. This year the strenuous rivalry that has heretofore characterized the shows is absent. Patent suits have passed into oblivion and the only reason two shows are to be held is that no one building in New York is large enough to accommodate all of the manufacturers.

Many thousands of people will obtain their first glimpse of the new Grand Central Palace. To those who still have the old building of the same name in mind, the new structure will prove a revelation. It is located two blocks north of the old Palace, at Lexington avenue and Forty-seventh street.

### Quakers to Show Amid Splendors

PHILADELPHIA, Dec. 26.—When the doors of the First and Third Regiment Armories are simultaneously thrown open for Philadelphia's eleventh annual automobile show on Saturday evening, January 13, an attraction second in interest only to the exhibition itself will be the decorative scheme employed, without a doubt the most pretentious thus far conceived for a Philadelphia show. Charles T. Ashman, whose departure from time-worn methods formerly used, scored a hit last year, will again have charge of this feature.

The Third Regiment Armory, Broad and Federal streets, will depict a scene in the forest of Fontainebleau, France, the main decorative fabric along the eastern side of the building showing the depths of the forest in an autumnal sunset, approached from either side by a drive, representative of the road from Paris, in which driveway will be pictured automobile parties on their way to the forest. The north, west and south walls will be a series of panels presenting French scenes. As was the case last year, all unsightly woodwork and obstructions will be cleverly concealed and by suspending from the ceiling by means of an invisible wire, the individual signs designating the various exhibitors' booths, impediments to an otherwise sweeping view of the whole room will be eliminated.

At the First Regiment Armory, Broad and Callowhill streets, a scene will be presented of the approach to the Castle of St. Elmo, embracing a panorama of the Bay of Naples, the Italian Riviera, Mt. Vesuvius, Sorrento and the island of Capri. The side-walls will be decorated in balustrade effect, supported by a stone wall, overgrown with moss and plants, and dotted with trees.

The color scheme will be carried out in harmony with the surroundings, and as at the Third Regiment, suspended electric signs will be employed so as to furnish an uninterrupted view to visitors.

### Rhode Island Show in Palm Garden

PROVIDENCE, R. I., Dec. 26.—A particularly attractive decorative scheme has been worked out for the interior of the State Armory, Providence, during the week of the automobile show to be given by the Rhode Island Licensed Automobile Dealers' Association January 22-27, inclusive. The exhibition, which is the first in three years within the state, promises to be a record-breaker.

The general effect will be that of open-air palm garden, and

an azure sky will be manufactured out of cloth, hung just above the girders of the shed.

All of the exhibition space has been rented.

In the upper, or main hall, the pleasure vehicles will be shown. The basement hall, where the artillery companies are quartered, will be used for commercial vehicles and accessory displays. Forty-three different makes of pleasure vehicles will be shown in the main hall and sixteen styles of commercial trucks or delivery wagons will be found in the basement section.

### Bird Concert at Syracuse Show

SYRACUSE, N. Y., Dec. 23.—Automobiles worth \$500,000 and \$150,000 in accessories will be represented at the third annual show of the Automobile Dealers of Syracuse at the State Armory in March. Every exhibitor will be expected to insure his display; and a wise precaution, worthy of general imitation, is a requirement prohibiting any gasoline or explosive in the hall. Machines running thither under their own power will be required to have their gasoline siphoned out before being taken inside.

There will be an immense fountain, electric showers of lights in fine designs and the "bird symphony." The latter feature is borrowed from the recent industrial exposition here. From the center of each first floor booth will be suspended a birchbark basket cage containing a canary bird, all picked songsters. The success of this "concert" at the former affair has dictated its repetition.

### Space Allotted for Boston Show

BOSTON, MASS., Dec. 26.—Chester I. Campbell, manager of the Boston automobile show, who is just back from a tour of the European shows, says that he did not see anything there in the line of decoration and arrangement that seemed original enough to be adapted to the Boston show.

Now he is busy with the plans for the March show, which this year will last two weeks, the pleasure cars being housed in Mechanics' building the first week and the commercial vehicles the second week. Practically all the space has been allotted and the dealers are able to get some idea of how much room they will have in which to show their models.

### Detroit Space All Under Contract

DETROIT, Mich., Dec. 26.—Space in the Wayne pavilion and temporary annex, for the eleventh annual automobile show of the Detroit Automobile Dealers' Association, is now all assigned, the final drawing having taken place last Friday night.

There were forty-three applicants for the 10,000 additional feet of floor space afforded by the annex, and most of them were taken care of, although some of the exhibits will be somewhat cramped. There was a large representation of motor car manufacturers at the drawing and this branch of the industry will make a very creditable showing at the exhibition.

Work on the annex will be started next week, and will be rushed.

### Atlanta Show Will Be February 10-17

ATLANTA, Ga., Dec. 26.—The Atlanta Automobile and Accessory Association will hold its first automobile show February 10 to 17, in the local Auditorium-Armory, where the first and only national Southern show was held a couple of years ago.

As a result of a series of meetings it was decided to hold the show and to pay for it by charging exhibitors 50 cents a square foot for all space used. This, it is estimated, will pay all expenses. Then all receipts from other sources will be divided among the exhibitors.

The committee appointed to arrange for the show was H. G. Moore, manager of the Atlanta Velie Branch, chairman; W. D. Alexander, of Alexander-Seewald Co.; D. T. Bussey, of the Georgia Motor Car Co.; Charles L. Elyea, of the Elyea-Austell Co.; F. T. Long, manager of the local Cole branch; John E. Smith, Pierce-Arrow agent; Wyllie West, manager of the Firestone branch, and Frank P. Day, manager of the Locomobile branch.

The committee is now soliciting the field and expects within a few days to sell all available space. In the meantime a manager will be appointed and actual work begun.

The curbstone brokers, against whom there has long been a bitter feeling in Atlanta, will be barred from the show and no cars except those represented by members of the association will be allowed in the exhibit.

### Sliding Space Scale at Baltimore

BALTIMORE, Md., Dec. 26.—A. S. Zell and H. M. Luzius, constituting the committee on floor space for the Baltimore show to be held in the Fifth Regiment Armory, February 20 to 28, inclusive, under the joint auspices of the Automobile Club of Maryland and the Baltimore Dealers' Association, plan to have three sizes of floor space. These will be the minimum, intermediate and maximum. The dealers will be notified to file applications before January 20.

After that date the space in the Armory will be reckoned with that required by the dealers and if the Armory floor is not large enough, each applicant will be reduced on a percentage basis. The dealers will then be notified of their spaces and also the date for drawing.

### Show at Canadian Capital

OTTAWA, Dec. 26.—The Ottawa Valley Motor Car Association is working hard to make its first annual automobile show a great success. Already nearly all of 40,000 square feet available has been sold and the exhibition promises to be complete in every detail.

Canada's crack band, the Governor General Foot Guards Band, of 50 pieces, will furnish music. The opening promises to be an event. The House of Parliament will be in session during the week and the fact of nearly 500 members of the house being here at that time, from all over the Dominion of Canada, appeals greatly to exhibitors, as many customers and prospective buyers of automobiles will be tempted to attend the show.

### Particulars in Lozier Cases

A sharp check has been given to the proceedings filed by Fletcher R. Williams and Joseph L. Rhinock against the Lozier Motor Company, charging breach of contract to sell control of that company. The New York Supreme Court has entertained a motion to require the plaintiffs to file bills of particulars in the actions, specifying the nature of the contract and all its circumstances.

It was planned to have the cases tried on their merits this month, but the court order requiring amendment to the complaints may have the effect of deciding the case in the Appellate Court as the attorneys for the plaintiffs have the right to appeal from the order of court to file bills of particulars and the upper court may then take jurisdiction of the matters on the law point raised.

According to the attorneys for the Lozier Company this will probably be the result. Under the circumstances the plaintiffs are ordered to file the particulars immediately or take appeal and the latter course is considered more likely. The pleadings so far submitted tend to show that Williams was not the sole financial man involved in the alleged contract of purchase, but that George B. Cox, of Cincinnati, was also interested. Rhinock figures as an agent in the suit.

Arrangements are being made for special nights with special attractions. Manager Louis Blumenstein is busy allotting space. The decorations will be in the handsomest and most striking that can be obtained.

### Hudson Terminal as Show Place

Down in the concourse of the Hudson terminal building in sight of thousands of Jersey commuters the Abbott-Detroit Motor Company has placed an Abbott-Detroit car of latest model and a Regal colonial coupé. The two cars attract much attention and have provoked many inquiries.

### News of Other Local Shows

DENVER, COL., Dec. 26.—Plans for the Denver automobile show, which will be held in the Auditorium March 4-9, are being rapidly matured, and from present indications the exhibits will exceed those of any previous year. So heavy is the demand for floor space that it will probably be necessary to build an additional display room in the street adjoining the Auditorium. The Studebaker exhibit will be sent to Denver entire from the New York show and other dealers are planning special features which will not be ready for announcement until later.

ELMIRA, N. Y., Dec. 26.—The second annual show will be held at the State Armory, February 26 to March 2. The entire main floor space has been sold and 34 different makes of cars will be shown. Great interest is being taken in the forthcoming show. One of the features will be the decorations. The entire basement will be given over to accessories. Louis Blumenstein has been appointed manager.

STOUX CITY, Ia., Dec. 26.—The Sioux City automobile show will be held from February 26 to March 2. The date was chosen at a meeting of the Sioux City Automobile Dealers' Association, last week. This date was selected as it follows the Omaha and Minneapolis shows, and precedes the Des Moines show.

TROY, N. Y., Dec. 26.—The Troy Automobile Club will hold its second annual show at the state Armory, Troy, during the week commencing Monday, February 12, and all indications point to it being one of the biggest and most spectacular events of this character ever held.

HARRISBURG, PA., Dec. 26.—The third annual automobile show of the Harrisburg Automobile Association will be held at the Arena February 3 to 10. There will be exhibits by automobile dealers and dealers in tires and automobile accessories.

### Bars Unnecessary Noise

Chicago has placed the automobile horn in the same class with locomotive and street car signals by creating a law forbidding their use save as a warning of danger. Moreover, the city has taken another step forward by defining, for the first time in the history of municipal legislation, just what an adequate automobile signal is, by providing that no device shall be used as a signal of warning save that which gives an abrupt sound. This means that, no matter how much noise might be made with a warning signal, to make other than an abrupt sound will put it in the power of the court to fine any person guilty of unnecessarily sounding his signal \$25.

### N. Y. Car & Truck Co. Declares Dividend

Creditors of the bankrupt New York Car & Truck Company will receive a small remembrance about New Year, as a dividend of 2½ per cent. has been declared by the receiver of the defunct company. The claims that will participate foot up \$151,000 and thus the amount to be distributed is about \$4,000.

One of the largest claims in litigation against the company is that of the Allen-Kingston Motor Car Company, which is suing for about \$25,000 for breach of contract.



# Trials of the Non-Technical Scribe

**H**IS head was swirling in a seething mass of figures. They looked and felt like two dozen W. W. equilibrators somewhat tangled and bumping from one thought wave to another, and every bump jerked loose something in his delicate cerebrum. He was a reporter, just then, and he had been sent out to get a special story on "The Ambitions of the Automobile Industry." He had just emerged from ten minutes with Mr. Alpha, five minutes with Mr. Beta and fifteen hard minutes with Mr. Omega, these being the gentlemen who are duly appointed to say the first, the second and the last weighty word on the greatness of everything self-propelled. Handing out some nicely typewritten schedules to assist the faltering memory, each of them had managed to convey the impression that a great deal more was true than could be put into type and figures; these were simply safe, conservative estimates based upon a personal and thorough canvass. As for the future, the figures would probably be doubled in another year, as they were so much below the facts to-day. Ambitions? Oh, yes, he had asked about ambition. Well, what more could he want! Here it was.

"Suffering Amphortas!" exclaimed the young man—for the shrewd city editor always sends out a young, enthusiastic man when he wants an unvarnished story for a campaign review—"300,00 automobile wage earners in Detroit alone; a total invested capital of \$891,345,221.46; 197,315 motor vehicles produced in the fiscal year ending—well, would not that roll you over?—2,152,023 pneumatic India rubber tires aggregating a market value of \$186,245,789.20. Hold my hand! I am sure going to spring these numerals on O'Shaughnessy before they go to the desk."

O'S. turned out to be a United cigar clerk with orders to say "thank you as if he meant it" when handed good money. Privately he considered himself in training for a position as trust magnate and handled coupons with a fond, clinging touch. "Ben," he said, when confronted with the automobile magnitudes, "don't you try to hand out those figures for hot stuff. They are not in it with ours. Look here." And he pulled out a strip of cigar statistics from a notebook. The figures were decidedly longitudinal. "Take my word for it, Ben, old man, you are in wrong. Figures don't stagger anybody any more. I have turned loose these," and he waved the strip, "on lots of fellows who come in here. No go! And they are longer than yours. One fellow who buys twofers on Fridays and twofer quarters on Mondays just gave me the ha-ha. He said 'They have got machines now for turning out them statistics, I hear, and longer ones than that.' No, Ben, go and get another story."

O'S. was Ben's trial public, and Ben took the hint. What he handed to the city editor was something different. It was a chain of interviews with automobile owners, but it was never printed. "Put it somewhere else," the old man told Ben, handing him back the copy instead of shoving it into the hamper for superfluities; "it does not go on this sheet. What else have you got?"

Ben had conceived the brilliant idea of hunting up half a dozen young Tech chaps who owned automobiles, and his fraternity pin had eased matters along. "Whatever they think is the matter with the automobile industry it ought to be up to the automobile industry to change, and I can get my dope that way. I can't help it if they are not ambitious; they ought to be. Whoever heard, anyway, of any soulless industry having ambitions? It is the wrong cue." Ben was quite sure that the young chaps were just the right kind of persons. They did not care much for figures—"lay figures' don't go with me," one of them said in his young technical pride—but they claimed to be very strong

on facts and they were exceedingly liberal in wanting things done differently. What they had told him was Ben's copy, and it was very long. "How near straight is it?" he was asked. "Too near," Ben replied with a droll tinge of sadness; "I don't know much about it myself, so I could not have prinked it up if I had wanted to. It's sure the voice of the public, if there is one." Old people do not count in Ben's estimation.

With liberal omissions, the gist of the remarks of his various authorities is condensed in the following: "An industry does not interest anybody except those who are in it or expect to get into it. It is the art of building automobiles and the progress in getting better and better results for the benefit of the user that interests the public. Some very fine problems are involved in making 10,000 automobiles with a capital of \$10,000 and making them all alike and selling them at a profit at \$1,000 for each and having each of them better than anything that could be bought for four times more money four years ago, and all those things. But there has to be division of interests in this world, just as there has to be division of labor, unless one is willing to split oneself up into atoms. An individual's interests cease distinctly when nearly all the things that are done are aimed at money-making for the other fellow and every improvement is pushed aside because it interferes with the regular routine of manufacture. The other fellow is vitally concerned, of course, as are all those who are to share in the profits. A little glow of satisfaction can even be derived from reflecting that the time is drawing nearer when every farmer and every expressman will be able to buy a car to help him out in his business. But every one can't be in these lines. Meanwhile it would be much more interesting to learn that, for example, a plan had been devised for doing away with the gasoline tank. Someone might get up a standard size of gasoline can—to hold three gallons, say—and have that sold all over like sugar, only sealed; and provide a couple of cradles with clamps for holding these cans in each car and an attachment with a nut and a pipe or anything to enable one to draw direct from either can. When one can was empty start drawing from the other and at the next stopping-place simply exchange the empty can for a full one. There would be decidedly less bother pouring gasoline or getting it dirty or full of water, and there would always be some on tap. The cans could be removed at home and the owner could store his car where he pleased without getting into trouble with the insurance people."

"No use," said Ben to himself, "to ask these people if the special machine tools which they get up for producing 10,000 cars in a series and at low price don't sometimes make better cars as well as more of them, but I will ask the next fellow, and if he makes another kind of a break I will take that up with the third man. When I get to the end of the string, I think I shall have something that way."

## Hoosiers Raise License Rates

INDIANAPOLIS, Dec. 26—A new motor car license ordinance has been passed by the city council of Indianapolis and has been approved by the mayor. After January 1 the following fees will be charged annually: Three passengers and under, \$5; four passengers and over, \$8; private and public buses and delivery wagons and trucks of more than 1,000 pounds capacity, \$15; delivery wagons and trucks having a capacity of 1,000 pounds or less, \$10. The present license fee obtaining in the city of Indianapolis is \$3 for all classifications of self-propelled vehicles.

# Reserve Parts Stock System

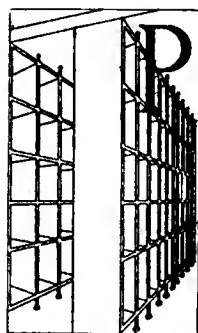

**R**ESUMING that the repair or service department of a company is organized and conducted rather with the object of increasing the comfort of the company's customers than to profit on the work of the department itself, the importance of an all-embracing system makes itself evident at once. A service department, if it would render quick and effective service, must contain several pieces of every sort of part used on the company's automobile. This sounds fine enough, but when one remembers that there are some 3,000 different parts comprising the make-up of the average automobile, the situation immediately takes on a different face. The man who has never entered in the stock room of the repair department has no idea of the amount of material stored and handled there, and what is most important, kept in good order. Unless he keeps this point before him, at all times, the vastness of his stock will avail nothing to the department head either and will not tend toward his success. It should never be forgotten that the service department is a small factory, and, as in a factory, space, time and labor must by no means be wasted in the process of conducting the business of the enterprise.

The principal difference between service department and factory lies in the part played by labor in both cases. In factory work labor is by far the most important of the three items named above. Even if space and time are not utilized as they should be, with a certain loss of labor as the result, this fact will hardly ever determine the success or failure of a factory's operation. But in a service department the situation is different. Unless everything is kept in the most painstaking order, too much time will be lost in looking for the parts sought, with

**How the New York Service Department of the Mitchell Motor Car Company Arranges Its Spare Parts to Advantage, with an Up-to-Date Inventory Always at Hand**

factory lies in the part played by labor in both cases. In factory work labor is by far the most important of the three items named above. Even if space and time are not utilized as they should be, with a certain loss of labor as the result, this fact will hardly ever determine the success or failure of a factory's operation. But in a service department the situation is different. Unless everything is kept in the most painstaking order, too much time will be lost in looking for the parts sought, with

But in a service department the situation is different. Unless everything is kept in the most painstaking order, too much time will be lost in looking for the parts sought, with

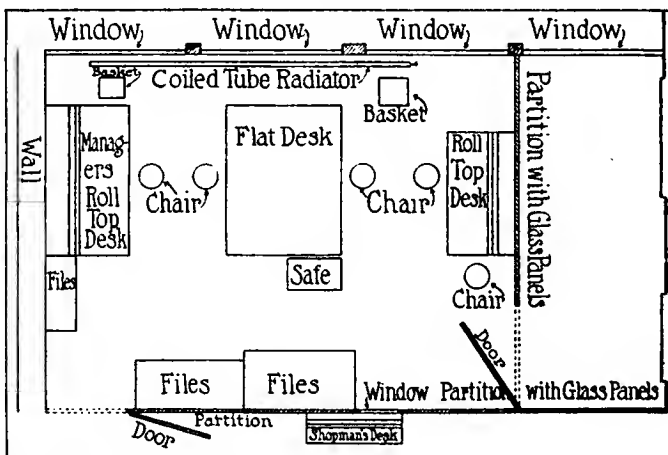

Fig. 2.—The office of the stockroom is located adjacent to it and so furnished as to permit a maximum of light to find its way to the store-room proper

Water Pipes	Water Pipes	Water Pipes	Water Pipes
Nuts & Bolts	Fan Belts	Fan Belts	Pump Bearings
Pump Casings	Water Wheels	Water Wheels	Water Wheels
Strainers	Strainers	Fan Blades	Fan Blades
Fillers 17" long x 16" deep	Filler Caps 17" long x 16" deep	Drain Cocks 17" long x 16" deep	Fan Blades 17" long x 16" deep
Pump Casings 24" long x 22" deep	Water Pumps 24" long x 22" deep	Pump Gears 24" long x 22" deep	
Fans 38" long x 34" deep			
Radiators 48" long x 28" deep			

Fig. 1.—Arrangement of parts of cooling system in the Mitchell storeroom. The height here illustrated is full in proportion to the width

a consequently large loss of both labor and business. Lack of systematic arrangement has been the cause of failure for more than one repairer, whereas the introduction and maintenance of a thorough system has done much toward conducting a repair department without a loss, sometimes even at a profit, and producing a satisfied clientele in the case of many a successful company.

The Mitchell Motor Company, which has just moved its New York service department to 41 West Fifty-fifth street, has installed an adequate system there. Of course, some system had been used in the old quarters of the company's repair department, but experience showed that it could be improved in many respects, and when the department's location was altered the management used the occasion to introduce many innovations and improvements in their system of keeping the stock of repair parts in order. It had been found that an eternal inventory was a desideratum, but a system leading to it could not be introduced while still in the old quarters. Moreover, during the past few years many improvements in the arrangement of the parts had suggested themselves to the management. All these new ideas were carried out in the new building, and when the rush of work came on right after the place was thrown open to the Mitchell clientele, the increased efficiency which made itself felt at once proved the wisdom of the departures made by the management.

The offices of the stockroom and the parts storeroom are located on the fifth floor, and the arrangement of each is seen in Figs. 2 and 3 respectively. The desks in the office are so placed as to keep as little light as possible from entering the store-room adjacent to it, and for this purpose a flat desk is used in the center of the room, while the manager's roll-top desk and one more desk of this kind are placed against the wall and the

partition near the elevator, respectively. As Fig. 2 shows, the entire front of the room is of glass windows reaching from about 2 feet above the ground to the ceiling and permitting plenty of light to enter, especially since the buildings on either side of the street are not high enough to keep the light away from these windows. A coiled-pipe radiator runs along almost the entire length of the window, providing enough heat in winter time. No space is wasted in the office, and only as many files are kept there as are necessary. Likewise, two waste baskets are all that are provided, and, besides the chairs for the force, a small safe is all that remains to be mentioned of the equipment of this room.

A swinging door leads from the hall space into the office and another door of the same type thence to the storeroom. This place has a perfectly workman-like appearance, and resembles an office in no respect expect that a small roll-top desk for the foreman is located next to the partition separating office and storeroom. The rest of the arrangement used in this room is

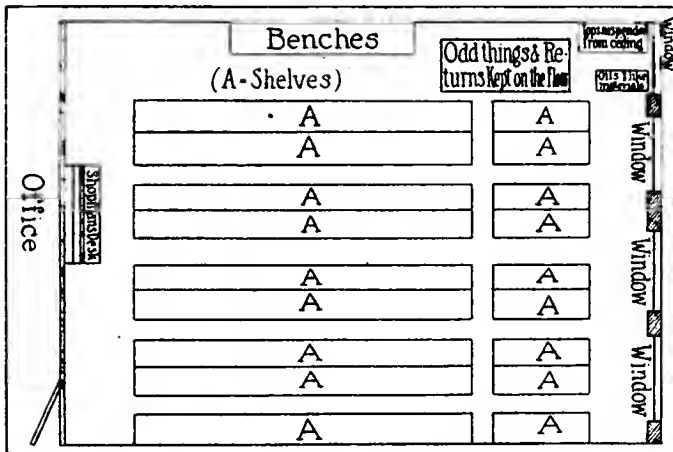

Fig. 3—Floor plan of the room in which the repair parts for all models are kept, showing the advantageous arrangement of shelves for storing the parts

shown in Fig. 3, indicating the position of shelves and working benches, as well as the places where large parts are kept. There are practically seven rows of shelves, each 13 feet high. The total length of each shelf series is about 65 feet, while the depth of the shelves varies. The compartments nearest to the ground have a depth of 34 inches, while the following higher rows are 28, 22 and 16 inches deep, respectively. This latter figure is the minimum depth; that is, upward from about 6 feet above the ground every compartment extends that distance in from the front. The variation in depth is noted on the diagram of a number of shelves illustrated in proportion to their actual size in Fig. 1. Here is also seen the idea embodied throughout the stockroom in regard to the arrangement of parts. The large units of the automobile, such as assembled motors, transmissions, differentials, radiators, and so forth, are kept in the bottom row of shelves, while the parts making up these units are stored in the compartments above. Fig. 1 shows clearly how this idea is carried out. Above the assembled-radiator compartment fans and pumps are stored, which are followed by filters, filler caps, fan blades, strainers, pump casings, fan belts, bolts and nuts for the cooling system, etc. The leading motive in this arrangement is weight, and, to a secondary extent, importance of the parts.

Each compartment or bin is numbered, and the numbers run from one end of the row to the other, and back in the next row above. The numbers of the assembled units bear no relation to the numbers of the parts stored above them, but the only relation there is is contained in the relative position of the bins. Passing from the office end of the row next to the working benches, cooling systems fill up about one-third the length of this row. Every bottom bin contains a radiator, and the various parts of the systems are stored in the upper bins.

The rest of the first row, before reaching the aisle seen in Fig. 3 is devoted to carburetion and ignition. With carbureters arranged in the two bottom rows of compartments, and all such parts as go to complete the gasoline-air mixing and transporting system, as butterflies, inlets and outlets, piping, draincocks, throttle levers and rods, about half of the shelf row is filled. The remaining portion of the first row is used for storing magnets and various ignition sundries, including wiring, batteries, terminals, sparkplugs and so on.

Passing through the aisle and coming back along the row of shelves backing the first, the storage place for wheels and their parts is next to the aisle, while springs take up the next section of the row, with leaves, bolts and other suspension parts located in the higher-up compartments. The steering system fills practically the rest of the row. Completely assembled steering gears fill up a number of ground bins, and above them a place is provided for steering posts, sectors, steering knuckles, drop arms, bolts and all the other members of the system which makes up the brain of the automobile. Body parts are filling whatever space is left of this row, and this class of material is continued in the next row, where reserve seats, leather hood- straps, doors and door-locks occupy advantageous positions. The bottom bins of this row are mostly filled up with tire side-rings, while on top of the shelves mudguards are located. Front wheel parts are next in the arrangement, hubs and wheels being stored in the lower bins, with bearings stored above them and the top compartments filled with such smaller accessories as front wheel bearings, oil-cups, balls, races, hub-caps, etc.

Transmissions hold forth in the next row. Complete gear-sets, assembled in their boxes, are stored in the two rows next to the ground, all of them being neatly arranged and placed beside one another, so that no difficulty nor loss of time is encountered when one of them has to be taken out of the store. Transmission housings and shafts are found directly above the com-

Part No. J-51 Price ✓ Limit 0 R. T. S. 1909 Bin No. 69  
 Name Water Wheel

DATE	ON ORDER	ORDER NUMBER	RECEIVED FROM	NUMBER TAKEN OUT	SALES ORDER	WORK ORDER	IN STOCK
			FACTORY	OTHER SOURCES			
10/20							18
10/28					1 17825		17
10/30					1 17881		16
11/6			4				20
11/7					1 18017		19
11/11					1 18149		18
11/13					1 18165		17
11/16			8				25
11/17						6856	24
11/18						6892	23

Fig. 4—Sample of an inventory card such as is attached to each bin. If entries on this card are made conscientiously, it will prove very efficient

plete sets, being followed, as the eye strays upward, by gear-wheels and bearings on which the transmission shafts run, not forgetting nuts and bolts holding the working members together.

An inspection of the following row reveals the arrangement that has been evolved to store crankcases and other heavy portions of the car to the best advantage. Crankcases take up so much space that some of them are kept in front of the shelves, while several ground compartments are filled with them. Brake systems, consisting of brakes, brake drums, bands, rods, pedals and levers, brake lining and smaller parts occupy the remaining length of the row.

In the sixth and seventh rows rear axle assemblies and elements are stored. Complete assemblies are, of course, kept in the bottom bins, as are rear axle sections, drive and jack shafts, while differential gears and housings, bearings, bevels and pinions, torsion tubes and extensions are stored above the heavy parts, and to fill some spaces in this division muffler parts and fender brackets have also been located here.

Across the aisle, beginning with the seventh row, engine cylinders are stored in the lower bins, while mufflers and muffler parts are kept above them. Accessories of a varied nature, such as sponges and chamois, have not been forgotten. In the following rows oilers, pumps, muffler shells, tire brackets and flexible tubing are found, whereas complete mufflers are kept on top of the shelves. Windshields and their parts are stationed on the floor adjacent to the windows, and this holds good also for a number of axles and shafts which are not so dimensioned that they can be stored in bins. Again the small components of the units mentioned are stored in the spaces above them. The rest of the short rows contain engine parts, crankshafts, camshafts, tappet rods and valves, clutches, starting cranks and straps, water jackets, connecting rods and other members of the power plant. Tire rings are stored in some of the bottom bins, with tire cases next to them, and such parts as brackets, both for tires and lamps, in the higher bins. Side levers and parts follow, and then comes a supply of inner tubes. Care has been taken to keep all rubber goods in a position well protected from the light. Whatever space is left is occupied by thrust bearings, foot levers and pedals, acetylene generators, cardan shafts, universal joints and elements of the latter.

Between the shelves and the wall, next to which the benches are placed, various material is stored. Many of these things are faulty parts returned and replaced under the guarantee, and others special equipment not included in standard cars. Oils, tire healing compounds and similar things are kept on a narrow shelf near the window, and facing them tops are suspended from the ceiling, one close to the other, avoiding all waste of space.

Beside the material kept in this storeroom there is a number of rear axle assemblies for which there is no room in this department. They are kept in a place two floors below the stockroom, where also a number of chassis are stored. But the bulk of the repair parts, in fact, everything that may be needed every day in the year, is kept in the regular stores on the fifth floor.

The special and live inventory system of the Mitchell company has yet to be described. It consists of cards, Fig. 4, one of which is hung on a nail above each bin, and on which the quality and quantity of the bin's content is noted. Fig. 5 is an actual reproduction of a card used on compartment No. 69, in which waterwheels for the circulating pump are stored. When stock was taken on October 20, the day after the company had moved to the new building, eighteen waterwheels composed the stock. This state of things, however, was changed when eight days later a waterwheel was taken out of the stock, to be used on sales order No. 17,823. This sale was not done on a new car, but it was really an order for the repair part sent in by an out-of-town Mitchell agent, who required the part for one of his customers. The so-called sales order generally does not contain the name or description of the part, but only the part number, which in this case is J-51. The mark R. T. S. 1909 refers to the model and year of the machine for which the waterwheels kept in this compartment were designed.

On October 30 another waterwheel was taken out of stock, reducing the number of wheels to sixteen. Meanwhile an order has been sent to the factory and Racine, Wis., to send a fresh supply of four waterwheels, which arrived on November 6, as may be seen by referring to Fig. 4. Within one week three wheels were again ordered by sales agents, but then a new shipment arrived, which increased the number of parts in stock to twenty-five. On the following two days one pump each was taken from stock, these times to be used on a repair order done on the premises.

Referring to the spaces on the card not filled out in the illustration, their purposes are as follows: Under the heading *On Order* the number of reserve parts ordered from the factory are entered the day when the order is sent there, and the number of the order sent to the factory is also noted. The reason for these spaces not being filled out on this card is that the parts which afterward came in were ordered before the company moved to its new quarters, and there started a new inventory.

Several times a year the number of parts in stock, which is entered on each card, is noted and the results of this work compiled by the office. For this end no book is used, but a card file with plain cards on which the part number, model and year, date of taking stock and amount of parts taken are written. By the use of the cards, Fig. 4, the work of correcting the file is very easy and may be done by two men in about two days.

While the inventory file is kept in the order of parts, letters and numbers, another file serves as a key to an initiate when he has to look for a part while no one is around to tell him where it is to be found. Supposing the man needed a bearing for the crankshaft on the 1911 Model T touring car. Looking under crankshaft bearings he consults the 1911 card and there finds for Model T the number 2,357. All that he has to do now is to go to the bin thus numbered, take out a bearing and make a note of the fact on the card. The whole operation takes less than five minutes, and with a man of average intelligence, if he has once been told how to use the system, there is no chance of an error in his handling it.

The total number of bins in the Mitchell stockroom is 2,853, and despite this large number the simple and yet elaborate system makes mistakes very improbable. There are 8,136,756 chances of making a mistake by misplacing parts in the storeroom containing 2,853 bins, but it is only due to a poor system or poor workers executing it if any of these mistakes happen. Naturally, when mistakes start in and increase, things must in course of time reach a state where the system is not worth anything. But in this case the remedy would lie only in the getting of the proper men capable of executing it and willing to do so. It must be remembered that even where a good system is introduced the personal equation plays its part, since it takes persons to handle the system; but since this is the case, failure, if it occurs, must be charged up to the factors that bring in the personal equation, and not to those which tend to do away with it.

**BLUSHES DEEPLY WHEN TOO HOT.**—A paint that sticks well to metals, or to most of them, and changes from a pink to scarlet, then to maroon and finally to black, as the temperature of the metal rises from ordinary to 50 deg. centigrade, to 70 deg. and to 85 deg., and which goes back to its original pink when the metal cools, is among the recent inventions of German chemists. It is offered under the name of "Efkalia," by Franz Korn, in Halle an Saale-Trotha. It may be applied on top of other paint and seems to promise a wide utility as a warning signal and heat indicator for spark plugs, cylinder heads and anything in factories which may run hotter than it should. It is stated that several fire insurance companies have taken it up. In suitable applications, it may evidently be used for experimental work, as for a ready determination of the operating conditions under which an automobile motor wastes or does not waste the calories with which it works, or for determining the efficiency of radiators or other cooling provisions.—From *Metall-Technik*, Oct. 28.

## Peeps Thro' Goggles at Distant Lands

**N**OTWITHSTANDING the rapid increase in automobiling in India, a most disturbing inconvenience lies in the difficulty which owners experience in obtaining spare parts from Continental European manufacturers. In some instances it has been necessary to wait three months for the arrival of parts. It is suggested that the waiting-time might be cut down materially by the registration of one's motor car and the coining of a mutually understood code between the manufacturer and buyer at the time of purchase, that needed parts might be cabled for.

Glasgow has just gone on record as having accomplished two acts of public service. The authorities have dispensed with every horse in the fire department except two, the horse-drawn engines having been replaced by motor-pumps; while the old horse-drawn prison van has given way to a modern motor-van, which is doing regular corporation service.

Following close in Glasgow's footsteps come Leeds, Manchester, Birmingham, Liverpool, Belfast, Dublin and London. In the first named six cities changes are being pushed gradually, motor-pumps crowding out the horse-drawn engines. In London the march of modern ideas is swifter. It was only at the last meeting of the London County Council that an appropriation was made and tenders called for to supply the fire department with thirteen motor-pumps. City authorities declare that within ten years there will not be a horse-drawn fire engine in any of the large cities of England, Ireland or Scotland.

Herr Von Dallwitz, Prussian Minister of the Interior, has just issued a decree declaring the blowing of motor-car horns as unnecessary, either by day or night, and accordingly he regards the making of such noises as a breach of the peace and as a misdemeanor, and he will see to it that offenders meet with punishment fitting the alleged crime.

A German has taken out a patent for warming the rugs or carpets on the floor of the automobile. The contrivance involves a series of wires which run through the carpet and the current being turned on, the result is a sufficient amount of heat to keep the passengers' feet comfortable in the winter.

A short Bill for amending the Motor-Car Act has been introduced into Parliament, which will relieve drivers of automobiles of the necessity of taking out duplicate licenses. Men are obliged, under the present system, to take out a police-driving license, in addition to the ordinary license from the City Council, a fee being exacted in both cases.

The British Government is still extending the use of the motor-car for the conveyance of mails. Over one hundred services or sets of services are now being performed, by motor-cars. During the year important services of this kind have been established between London and Portsmouth, London and Birmingham, Glasgow and Greenock, Dublin and Kells, etc. The motor-vans have replaced horse-vans in a number of services in London. The postal authorities admit that the greater speed of motor as compared with horse traction is of considerable advantage to the mail service.

During the year just ended, 800,000 gallons of tar were used on the county roads of Kent, England. The cost was over \$100,000. In addition, ninety-one tons of bituminous binding preparation was used, its base being asphalt. The result is that Kent has good roads.

France proposes to run a motor-car reliability trial over a distance of 5,000 kilometers during the early part of the year 1912, the cars to be divided into two classes. Light automobiles to include all machines, of which the price of chassis without tires shall not exceed \$1,600; and voiturettes, complete, the price

not to exceed \$800. It will be stipulated that competing cars shall be equipped with two-seated bodies, wings, steps, lamps, headlights and wind-shields. Not more than three machines may be entered by any one manufacturer. Repairs during the luncheon hour will be debarred. The regulation average speed for the light cars will be thirty kilometers per hour; and twenty-five kilometers is set for the pace of the voiturettes. The fees for entry are 500 francs for one car; 900 francs for two cars, and 1,200 francs for three cars entered by the same manufacturer; 250 francs for one voiturette; 450 francs for two voiturettes, and 600 francs for three voiturettes entered by the same manufacturer. The route, starting at Paris, is to comprise Besançon, Lyons, Grenoble, Nice, Marseilles, Montpellier, Toulouse, Bordeaux, Nantes, Le Mans, Rouen, Lille, Rheims, and return to Paris.

The London fire brigade has at last dispensed with solid tires used on runabouts or tenders, substituting pneumatic tires in their place.

A recent experiment in road-paving near Birmingham, England, has proven a success in many ways. It is called the new "leather pavement." The base of the composition is waste shreaded leather, reduced almost to a pulp. This is whipped into a batter with tar and bitumen, after which it is spread on a concrete road-bed. After it has become dry this new "leather pavement" settles down as hard as a rock and affords a smooth, cushion-like surface. The heaviest of motor-car wheels make no impression on it. Dust does not result from the traffic, nor does the road get greasy. It is weather-proof, noiseless, and a boon to the foot of the horse, as well as to the tire of the motor-car. Its cost has not been determined; but, should it not prove too expensive, it may make a great improvement in modern methods of road-building.

The County Council of Warwickshire, England, has passed a by-law making it obligatory for the occupant or driver of every vehicle, no matter of what type, bicycle, cart, carriage or motor-car, to attach a red light on the rear of the vehicle while passing through or traveling in the county.

The latest invention in the way of covering for automobile footboards is a matting made in picturesque designs from aluminum. One cannot slip on it and its metallic composition makes it easy to clean. It is also almost indestructible.

The automobile will soon be running over a section of the Congo territory which echoes its tales of barbarous deeds of mutilation in connection with the harvesting of rubber by natives. Already the motor-trolley has leapt out across portions of the land, the line threading dense forests. Preparations are on foot for the making of roads for automobiling, the contemplated scheme being to link up Broken Hill, Bwana Mkubwa and Luembe.

Odd as it may seem, motor-bus and tram-car drivers of gay Paris have been up to the present time allowed to smoke while driving their respective vehicles through the streets of the French capital. But the custom developed into such a nuisance that the public raised its voice in protest; in consequence of which the companies have issued orders to the men forbidding them to smoke during the hours they are on duty.

The Royal Swedish Automobile Club has revised the rules which governed the Gothenburg-to-Stockholm motor-car trial last winter, under which 48 and 60 hours respectively was the maximum time for the two classes. Under the new rules the minimum speed allowed will be 10 and 9 kilometers respectively per hour. Should the course exceed 600 kilometers the permissible speed will not include compulsory stops.



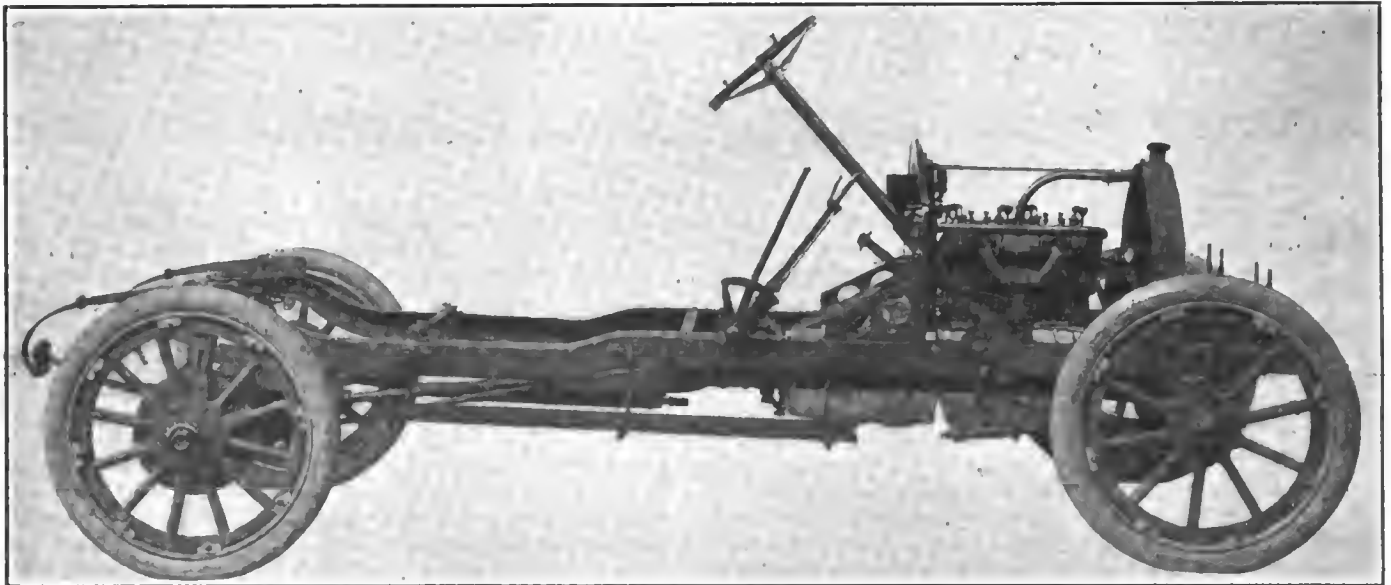

Fig. 1--View of chassis of the Bergdoll 30 for 1912, showing double drop construction

## Bergdoll Adds a Forty to Its Line

**R**ADICAL departures from the usual practice have not been made by the Louis J. Bergdoll Motor Company, of Philadelphia, Pa., in bringing out its line of cars for the season of 1912. The company is continuing to build the Bergdoll 30, which first characterized its line last year, but in addition to that a new and larger car has been added. This car is equipped with a motor claimed by the makers to develop slightly in excess of 40 horsepower.

The motor of the latter has a bore of 4 inches and a stroke of 6 inches, giving a stroke-bore ratio of 1.5, and has four cylinders

which are cast en bloc. The exhaust valves are located on the side of the cylinders and are placed just below the removable caps, so that they are readily accessible in case it becomes necessary to withdraw them. The water jackets are cast integrally with the cylinders and extend around the valve ports, thus adequately cooling these parts. The inlet valve opens downward into the head of the cylinder, while the exhaust valve opens upward. The inlet valve cage is readily removable so that this part is also easy to reach should it become necessary to remove the valve for purposes of inspection or repair. A noteworthy feature of the valves is that the inlet valve is provided with a flat seat while the exhaust valve seat is of the 45-degree type. In case it is desired to fit a duplicate set of spark plugs there is an aperture in the top of the cylinder sealed by a plug.

The flat head pistons on the new motor are 5 inches in length and are fitted with four piston rings located above the wristpin and ground to fit. The material of the piston is of selected gray iron, ground to a finish and balanced in connection with the other reciprocating parts of the engine. The wristpins are of hardened steel and are hollow in section. They are  $1\frac{3}{8}$  inch in diameter and the thickness of the metal is  $\frac{3}{8}$  inch. The upper ends of the connecting-rods are fastened to the wristpins by means of clamp bolts held by the bolts which pass through them. The connecting-rods are 12 inches in length and are drop forgings of selected steel. They are of I-beam section and at the lower ends are broadened to secure a bearing surface of good length on the crankpin.

The crankshaft is carried upon three main bearings of annular ball type, the rear end connecting to the flywheel member of the clutch, while at the forward end the shaft terminates in a gear which drives the half-time wheels. The crankshaft is of carbon steel drop forged and ground to fit. The crankpins are 2 1-8 inches in diameter and the connecting rods are bushed with die-cast metal to form a bearing surface for them. The connecting-rod bearing caps are of adequate size to guard against breakage at this important point.

The camshaft is readily accessible beneath a cover plate in the side of the crankcase. When this plate is removed the whole valve mechanism may be inspected and the camshaft bearing cages removed. The cams are an integral part of the camshaft

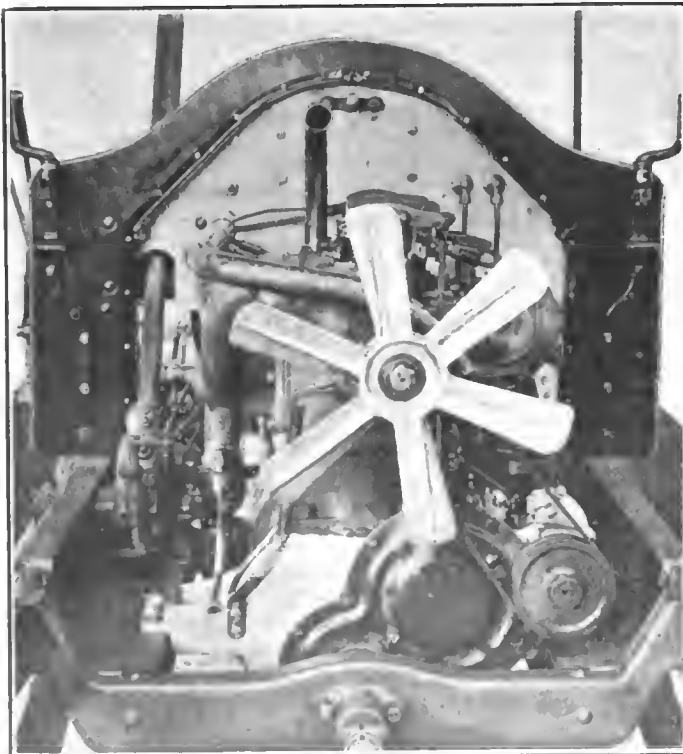

Front view of motor and dash of Bergdoll 30

and act directly upon the tappet rods and not through fingers. The camshaft is carried upon three annular ball bearings which are of large size in order to reduce wear on these parts; it is driven through a set of gears at the front end of the motor. These gears are encased in a housing, the cover of which is made removable by taking out the stud bolts which hold it in place. The last wheel in the train is used to drive the water pump and magneto shaft, while the middle wheel drives the camshaft. An Oldham coupling is inserted in the latter shaft, which is an exterior fitting, so that it may be readily taken down when such an act is necessary. The valve action is readily adjustable by means of the two nuts which may be seen in Figs. 2 and 4. The wear on the tappet rods is taken up by merely turning these so that the lost motion disappears. The valve springs are also exterior fittings and are thus readily accessible.

The crankcase is an aluminum casting and is extended back in order to make a housing for the flywheel. The motor supports are four in number, and are cast integrally with the crankcase, the rear two being on either side of the clutch housing. A shelf is cast on the side of the crankcase to support the magneto. The crankcase is in two parts, the lower being a factor in the oiling system, which will be described later. The upper part forms a basis of support of the cylinder casting as well as of the bridges which carry the bearings of the crankshaft and camshaft.

The motor is lubricated by the splash system. The crankcase is divided into four splash troughs into which the connecting-rods dip. Besides being divided laterally to form the splash chamber the crankcase is also divided horizontally in such a way that the casting has a double bottom. The upper bottom is molded in such a way as to form the splash troughs just described. Below the troughs in what may be called the lower bottom of the crankcase the oil is carried in a plain basin-shaped reservoir.

The reservoir in the bottom of the aluminum crankcase casting is filled through the breather pipe. In filling, the cover of the breather is removed, disclosing the filler opening equipped

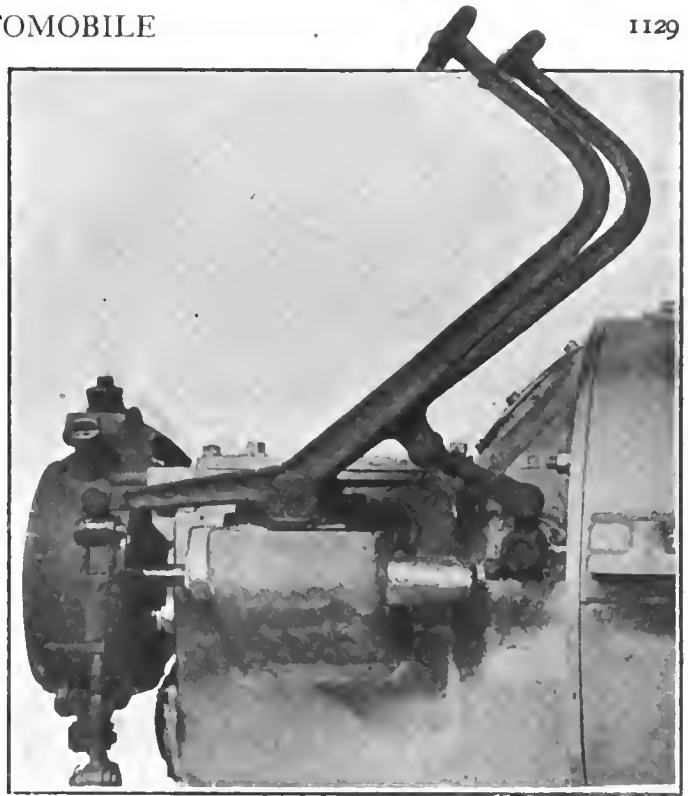

Fig. 3—Showing the unit housing of the clutch and control pedals

with a strainer. The upper test-cock on the side of the crankcase is left open while filling and oil is poured into the filler hole until it starts to flow from the cock. The cock is then closed tightly. The lower test-cock is for the purpose of draining the reservoir, the oil never being allowed to become so low that there will not be a flow from this cock. The breather pipe is located on the exhaust side of the motor, just behind the magneto shaft. The oil is drawn from the reservoir by a pump which

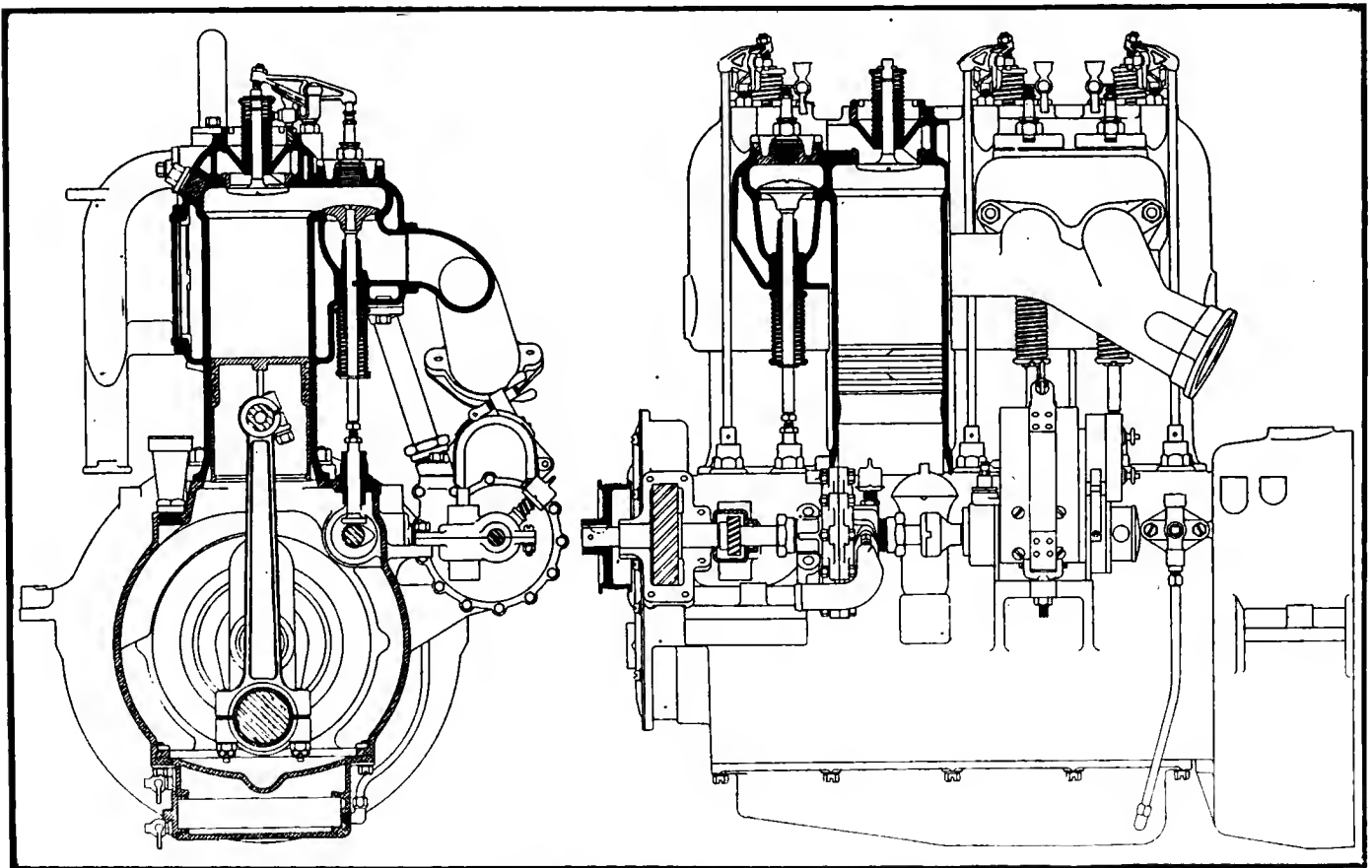

Fig. 4—Transverse section and part longitudinal section through the Bergdoll motor

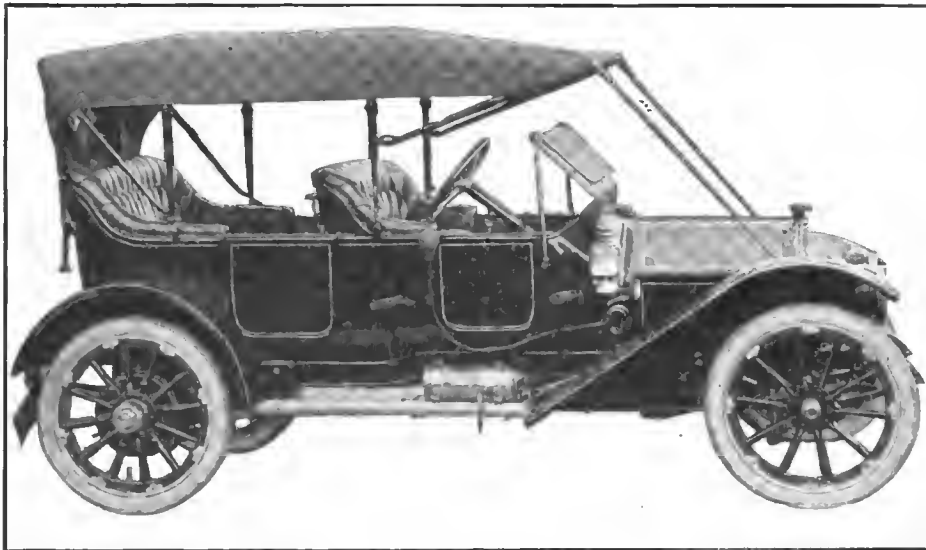
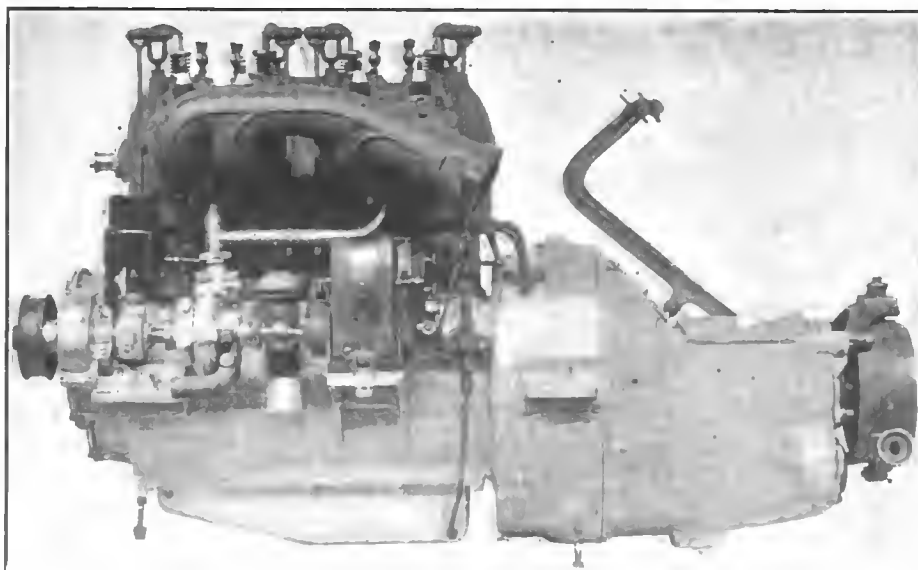

Fig. 5—Illustrating the Bergdoll torpedo touring car

takes the oil from a suction pipe leading to the pump from the rear end of the exhaust side of the motor. The oil is then forced up through a vertical lead into the sight-feed located on the dash. Thence the oil flows down onto the opposite side of the motor and is led into the crankcase at the forward end. The oil from this lead will fill the front splash trough and then overflow into the second and from there to the third and so on to the rear. After reaching the correct level in the rear splash trough the oil overflows back into the reservoir through an overflow in the rear of the crankcase.

Ignition is effected by a Bosch magneto known as the easy-starting type. With this magneto no batteries are required, and hence none are fitted on the Bergdoll cars. The magneto is readily dismantled from its position on the side of the crankcase by unscrewing the bolt which holds the clip over the top of the magnets. The bolt is mounted on a joint so that when the nut is loosened the bolt may be swung downward and the magneto lifted from its shelf.

The carbureter is of the automatic float-feed type. It is mounted on the right side of the motor and supported by a broad flange at the bottom of the Y-shaped intake manifold. Two bolts pass through this flange and a gasket is inserted to prevent leakage of the mixture at this point. The throttle is controlled from the driver's seat by a lever on the steering column in the usual manner. Adjustments may be made on the



A complete view of the motor, showing the unit power plant

carbureter by means of knurled screws which are fitted in an exterior position and govern the gasoline, air and automatic air intake. In order that the mixture be kept constant at all times the carbureter is hot-water-jacketed, the supply being drawn from the lower part of the water-jacketing of the cylinders on the right side.

The clutch is of the multiple disk type faced with asbestos fabric known as thermoid. It is encased in an aluminum housing which is a continuation of the crankcase as explained above. The rear part of the housing is formed by the casing of the gearset, which is so shaped that it fits against the rear of the flywheel casing and is held thereto by means of bolts. An inspection cover is fitted in the clutch housing, through which any necessary adjustments may be made, as it is large enough to permit the hand to easily pass into the interior

and manipulate any of the parts requiring regulation. The necessity for adjustments on this type of clutch, however, is negligible, being for the most part due to carelessness. The majority will be found to be cases where the operator of the car has neglected to give the clutch the ordinary care.

The drive is taken up from the clutch through a gearset of four forward speeds and one reverse. The drive and gear change shaft are of chrome vanadium steel, while the gears are all of nickel steel, a combination which should give great durability and strength against sudden stresses. The bearings which support the shafts are of the ball type and so designed as to withstand end thrusts when changes in speed are made and when the clutch is engaged and disengaged. The gearset is rendered readily accessible by raising the floor boards of the car, disclosing a flat cover plate which fits over the gearset. There are four bolts holding this plate in place and a gasket is inserted in the joint to make it oil-tight.

At the rear of the gearset there is a universal joint which separates the change-speed mechanism from the drive shaft through which the power is transmitted to the rear axle. This universal joint is for the purpose of taking up any changes in alignment which occur owing to the different degrees to which the car is loaded. A difference of one person in the load of the tonneau will change the slope of the shaft and hence alter the direction of the drive. This universal joint takes up this difference and renders it possible to operate the vehicle under all conditions of load. The drive shaft is of chrome vanadium steel and is fitted at the rear end with a universal joint through which the power is transmitted to the rear axle. The drive shaft is relieved of all torsional strains by torque rods which connect the rear axle and the chassis frame. The strains encountered when making a sharp turn are thus taken up by other members of the mechanism than the motor and drive, and hence will do no harm to these parts. The torque rods may be seen in Fig. 1, which depicts the chassis of the Bergdoll No. 30. The arrangement of the drive and the rods is the same on the two models.

The rear member of the universal joint on the after end of the propeller shaft is a part of the short shaft which passes through a stuffing box and into the differential housing on the rear axle.

At the rear of this short shaft, and also an integral part of the same, the bevel pinion which operates the large bevel wheel of the train of differential gears is found. Just within the stuffing box through which the short shaft passes there is a seating which holds an annular ball bearing. This in turn supports the shaft. Another ball bearing is located just forward of the star pinion and supports the rear end of this shaft as well as acting as a bearing for the star pinion. The large differential wheel is also carried upon ball bearings of annular type, and drives the differential wheels which in turn actuate the live axle shafts.

The rear axle is of the floating type, the housing being of pressed steel. The live members are all carried upon annular ball bearings and the material of which they are made is heat-treated nickel steel. The ends of the axle shafts are squared so that they may be readily withdrawn by simply removing the hub caps. When these are removed the ends of the shafts are disclosed and there is nothing else required but to simply draw them out. There is a flange on the end of the shaft to which the wheels are bolted. Six bolts form the means of connection between the wheels and the corresponding holding flange.

The brake drums are a part of the rear wheels. There are two complete and independent sets of brakes for service and emergency purposes. The service brakes are controlled by a pedal and are fitted with equalizers so that the pressure exerted on the drums on both sides of the vehicle is the same. These brakes are of the external type, consisting of bands which contract about the drums on the application of pressure on the pedal. The bands are faced with thermoid, while the drums upon which they act are of steel. The drums are 14 inches in diameter and  $2\frac{1}{2}$  inches in width, giving ample surface to bring the car to rest smoothly and rapidly. The emergency brakes, which are controlled by a lever, are of the internal expanding type. Upon application two internal bands are spread apart, turning about a pivot and bearing against the interior of the drum. The power is equalized on these two brakes in the same manner as in the other brakes; that is, through equalizing rods.

The wheels are of the Schwartz artillery type, the wood used in their construction being of second-growth hickory. The rear wheels are of slightly heavier construction than the forward pair, having twelve spokes while the forward wheels have but ten. The wheels are 36 inches in diameter all around.

A glance at the chassis of the 30, which is shown in Fig. 1, will give a general idea of the frame construction. The side members of the frame are of channel section and of dropped construction, being raised up over the rear axle. The material used throughout the frame is pressed steel and the various members and sub-members are hot riveted to each other. Two flanged triangular gusset plates are riveted to the side chambers and to the dash structure so that great stiffness in this part of the frame is attained. The motor is supported by a sub-frame of deep construction which is riveted to the main members of the frame.

The front axle is a single drop forging of selected steel and is fitted with large size annular ball bearings for carrying the front wheels. The steering gear is of the worm and gear type, and is controlled by an 18-inch hand wheel mounted on a five-armed aluminum spider. The spark and throttle control levers and quadrants are mounted upon the handwheel in the usual manner. The control is on the left side of the car throughout, and in the case of the fore-door models the levers are contained within the body. A self-starter of the Ever-Ready type is included on

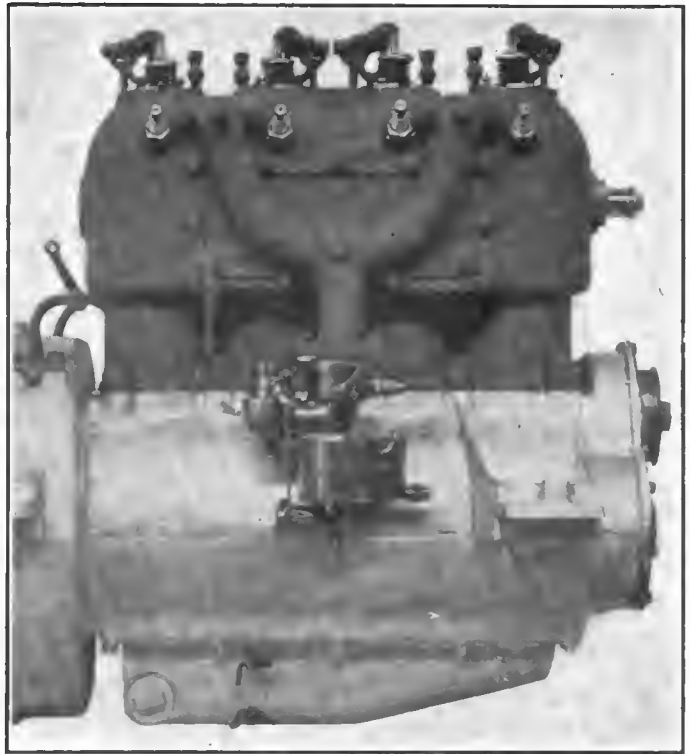

Inlet side of the motor, showing carburetor and intake manifold

the 40 if so specified by the customer, without extra charge. The starter is designed to be of use in starting the motor at any time, whether it be stalled or in starting for the run. It is guaranteed to start the same by a simple pressure on a pedal or lever which releases the brakes holding the mechanism and automatically cranks the motor.

The chassis is supported in the front upon semi-elliptic springs having a span of 39 inches and a width of 2 inches. The rear springs are 45 inches long and 2 inches wide, being  $\frac{3}{4}$ -elliptic in shape. The spring shackles are fitted with integral grease cups while the lubrication of the springs themselves may be accomplished by jacking up the car and applying the lubricant after the weight has been lifted from the spring.

This, however, will not have to be done very often as it comes in the category of overhauling. The springs are so shaped that the lubricant will be held in place for a considerable length of time without replacing.



Fig. 8—A view of the model C touring car of 1912 type

# Fluid Pressure Speed-Changing

CONSIDERABLE danger to transmission gears is involved in the possibility of changing and consequently stripping the gears while in mesh. On the other hand, even if speed-changing is done in the correct manner, with the clutch disengaged and the gears at momentary rest, the work of shifting the gears is not such an easy one as might be desired. These two setbacks of transmission gears are claimed to have been overcome in the construction of a speed-changing device by Allen M. Irish, of Bath, Me. The device consists principally in a balanced plug-cock which serves to regulate the flow of gas under pressure to the mechanism's working clutch and transmission gearset.

The general arrangement of the device installed is seen in Fig. 1, where P is the cylinder of the engine, or, still better, that of a mechanically operated air pump, charging air through check valve V into storage tank S, where it is compressed to the proper degree. A tube leads from S to the distributing valve V<sub>1</sub>, which is regulated through a shaft and gear attached at the top of the steering post right beneath the wheel. Fig. 2 is explanatory of the construction of the valve V<sub>1</sub>, Fig. 1, which was first referred to as a balanced plug-cock. Valve plug P, Fig. 2, is fitted into the valve body B, with passageways bored in it, permitting of the passage of a gas from inlet I to port T or higher up around the valve spindle S to the cylindrical space S<sub>2</sub>. This space is sealed upwardly by means of the valve V<sub>1</sub> which is held against the seat by spring S<sub>1</sub>. Tightness of the valve V<sub>1</sub> against its seat is insured through gasket G. The rod R serves to depress V<sub>1</sub> at the will of the operator, in which case the passage of the gas is continued the clutch supply port C<sub>1</sub>. C C are clutch exhaust ports, the function of which will be explained later on. The rod R is operated by operating lever O fulcrumed to it at F and pivoted at P<sub>1</sub>.

If the valve is in the position Fig. 2, the flow of the gases from the storage tank is illustrated by the horizontal section through the plane of T. Port T here registers with lead T<sub>2</sub> through which the gas is directed to the gear-shifting mechanism G<sub>1</sub>, Fig. 1. When T and T<sub>2</sub> registers as here illustrated, the operating lever O rests in a notch N<sub>1</sub>, Fig. 4, so that the valve plug is held in its position.

Lifting the operating lever as seen in Fig. 5 permits of rotating it until it comes to rest in notch N, Fig. 4. While the lever is out of engagement with either notch, T bears against the valve body B and valve V<sub>1</sub> is depressed off its seat, and the gas entering at I and passing in part by the port T<sub>2</sub> flows up around the spindle, leading through the clutch supply port C<sub>1</sub> to the clutch-operating cylinder, Fig. 6. The cylinder C is supported by frame F and closed at its other end by the cylinder cap C<sub>1</sub>. Plunger P is adapted to rotate in the cylinder, the piston rod is resting in the plunger hollow H, while the spring S serves to hold piston rod and plunger in constant engagement. Gaskets G and G<sub>1</sub> are provided as a double insurance against any gas leaking from the space containing the spring past the piston and out of the upper end of the cylinder. The gas coming from the distributing valve enters the mechanism at E and drives up the piston and plunger rod. The latter is fulcrumed to the clutch lever C<sub>2</sub> as shown, and this lever being pivoted at a place some distance from the fulcrum disengages the clutch. In lifting the rod R the action of a spring holding C<sub>2</sub> to the engaged position must be overcome, and as soon as the pressure driving up the piston P ceases to act, the piston returns to the position indicated by the dot-and-dash line and the clutch again drops into engagement.

This takes place after the operating lever O has completed its travel from notch N<sub>1</sub> to notch N and has come to rest in the latter. At the same time valve V<sub>1</sub> is lifted back to its seat, Fig.

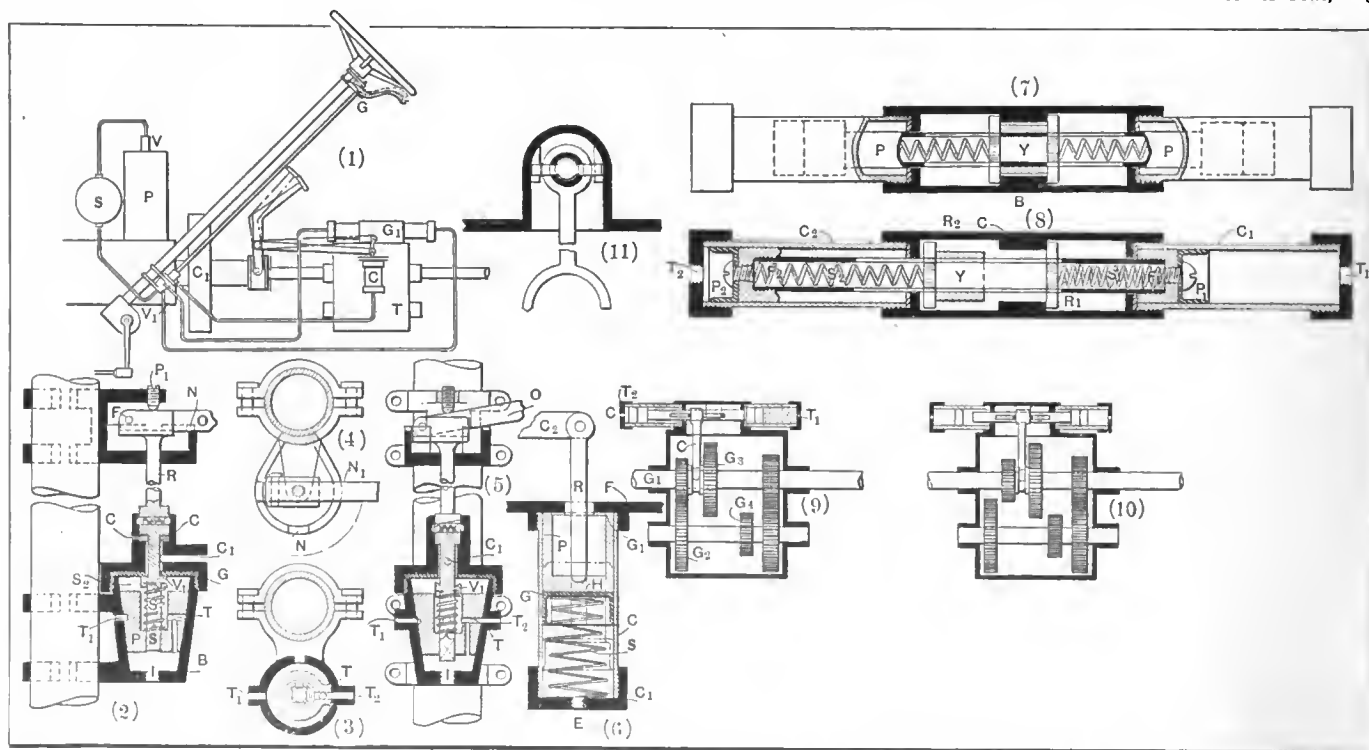

Fig. 1—General arrangement of Irish gear. Fig. 2—Method of attaching distributing valve to steering post. Fig. 3—Section through valve and post. Fig. 4—Operating lever and notches. Fig. 5—Lifting lever for shifting the gears. Fig. 6—Clutch operating mechanism. Fig. 7—Gear operating mechanism when gears are in normal. Fig. 8—Shifting gears by admission of gas through T. Fig. 9—How mechanism operates transmission gears. Fig. 10—Gears in neutral



2, and the gas contained in the gas lead to the clutch-operating mechanism is permitted to escape through C C in the same illustration. When O rests in N, port T registers with T<sub>1</sub>, so that the gas entering the valve body at I takes a different path.

The gas flowing through T<sub>2</sub> and T<sub>1</sub> flows to the gear-shifting mechanism, Figs. 7 and 8. The body of this mechanism contains a plunger P P, having attached to its ends pistons P<sub>1</sub> and P<sub>2</sub>, which slide in cylinders C<sub>1</sub> and C<sub>2</sub>. The middle portion of the plunger carries a yoke Y, while inside the plunger springs are fixed at respective ends F<sub>1</sub> and F<sub>2</sub> of the plunger. Spring retainers R<sub>1</sub> and R<sub>2</sub> by bearings against the portion C of the body limit the travel of the piston to either side, and tightness of all joints is insured by means of gaskets. Gas may be admitted to the spaces adjacent the pistons through ports T<sub>1</sub> and T<sub>2</sub> communicating with the outlets of the distributing valve marked in the same manner. The admission of gas has the effect of putting the spring on the admission side under additional compression, while the other spring remains undisturbed.

The operation of the speed-changing device is seen in Fig. 9. By admitting gas through port T<sub>1</sub> the piston is moved toward port T<sub>2</sub>. The yoke is thereby moved in the same direction, bringing gears G<sub>1</sub> and G<sub>2</sub> into engagement. The opposite movement of the plunger and yoke, caused by admitting gas through T<sub>2</sub>, would bring G<sub>3</sub> and G<sub>4</sub> into engagement. Gears are in neutral, Fig. 10, when the yoke occupies a central position, which is the case when no gas is admitted from the distributing valve if the port T bears against the wall of the valve body. Fig. 11 is a vertical cross-section through the speed-changing mechanism at the point of the yoke, illustrating the manner in which the latter is fixed to the body of the mechanism by keys sliding in guides.

The illustrations bring out a number of details which were not

specially mentioned in this description, but which will readily be noted by the man interested in this new construction. Apparently there is little or no difficulty involved in this device, and the only point demanding special care on the part of the maker would be tightness against air or gas under pressure, which can be obtained without too much trouble by exact fitting of the parts and sufficient packing of the joints by gaskets. No stuffing-glands are used throughout this apparatus. One of the refinements of the system is a shut-off valve interposed in the line between pressure tank and distributing valve, the shut-off being operated in connection with a lock, the key of which is in the owner's possession. This arrangement makes gear-shifting impossible when the car is left alone, but a positive locking means would be obtained if the operating lever of the device could be locked, by means of a key, when in a position between the two notches, for then it would be absolutely impossible to move the automobile by its own power without the owner's consent.

By the application of the Irish mechanism the clutch pedal on the footboard becomes superfluous, at least so far as this use of it is concerned. But incidentally the elimination of this member would allow the installation of a second brake pedal in its place, for advantageously working the emergency brakes of the car. Such an arrangement would do away with the rather troublesome situation of a motorist becoming unaccustomed to the use of the emergency brake, because this is unhandy as compared to the service brake operated more easily by its pedal. If, however, the emergency brake can be operated by foot, there is no cause for any disinclination on the part of the automobilist to use it when occasion arises. Besides these, there may be other advantages in this construction which its continued application may reveal.

## Harking Back a Decade

FROM *The Motor Review*, December 26, 1901:

The H. W. Johns Manufacturing Company, of New York, and the Manville Covering Company, of Milwaukee, have consolidated, the merger to take effect January 1. The name of the new concern will be the H. W. Johns-Manville Company. The company is completing a plant at Milwaukee for the manufacture of carbonate of magnesia and mineral wool.

It is announced that the International Motor Company, capital \$2,000,000, will handle the automobile business of the American Bicycle Company. George Pope has been elected president of the motor concern.

The Equipment Motor Company, capital \$6,500,000, has been incorporated in New Jersey and will handle the motor branch of the International Power Company. The Electric Storage Battery Company has won its suit to sustain the validity of the Brush patent before Judge Coxe in the United States court. The suit was brought against the National Battery Company.

Essex County, N. J., has struck a responsive chord in the hearts of automobile owners by raising the restrictions that have been laid against the operation of cars in the public parks within the county. All that the motorist now has to do is register and carry a number in rear and on his lamps; keep within the speed limit of 7 miles an hour; come to a stop if horses appear restive; sound no gong except in crossing a street; be ready to show permit to any guard and in case of failure to observe all these rules the permit will be rescinded permanently. The motorists are delighted.

Under the new French law the chauffeur who has part in any accident and then runs away will be subject to a fine of from 16 to 500 francs and imprisonment for from 6 to 60 days.

Foxhall Keene hired a plumber to make some repairs on one

of his racers last week. The plumber may be out of the hospital in a few days, his eyesight having been saved by the prompt efforts of physicians. Some hot resin blown out of a tube almost killed the man.

Joseph L. Brayton, of Cleveland, touring with his wife last week almost came to grief near Geneva, N. Y. A bull broke through a fence and charged the Brayton car. Mr. Brayton put on all speed and managed to escape although the bull was a good second for quite a distance.

The Bartholomew Company is preparing to enter the automobile business at Peoria. The company has been engaged in making peanut and coffee roasters and recently determined to go into motor car manufacture.

The price of Oldsmobiles will be increased to \$700 on January 1. This will make the second advance in price in 6 months.

The Automobile Club of America is engaged in a plan for affiliating the various American automobile clubs. The A. C. A. proposes to be recognized as the supreme head of automobile sport in America. This phase of the plan has met with some opposition.

Exports for the week, including both cars and parts, amount to more than \$46,000 from the port of New York.

The development of the motor vehicle has been so rapid that the sport, to which no better name than the most awkward one of automobiling has been given, is hardly yet in the club stage.—*Editorial*.

Henri Fournier, race driver, is quoted in *Success* of January as follows: "I look to see all the ordinary work of transportation in the great cities of the world done without horses. Everything will be done with more speed so as to relieve congestion, but the most important item about the coming of the motor is its cleanliness."

# Digest of the Leading Foreign Papers

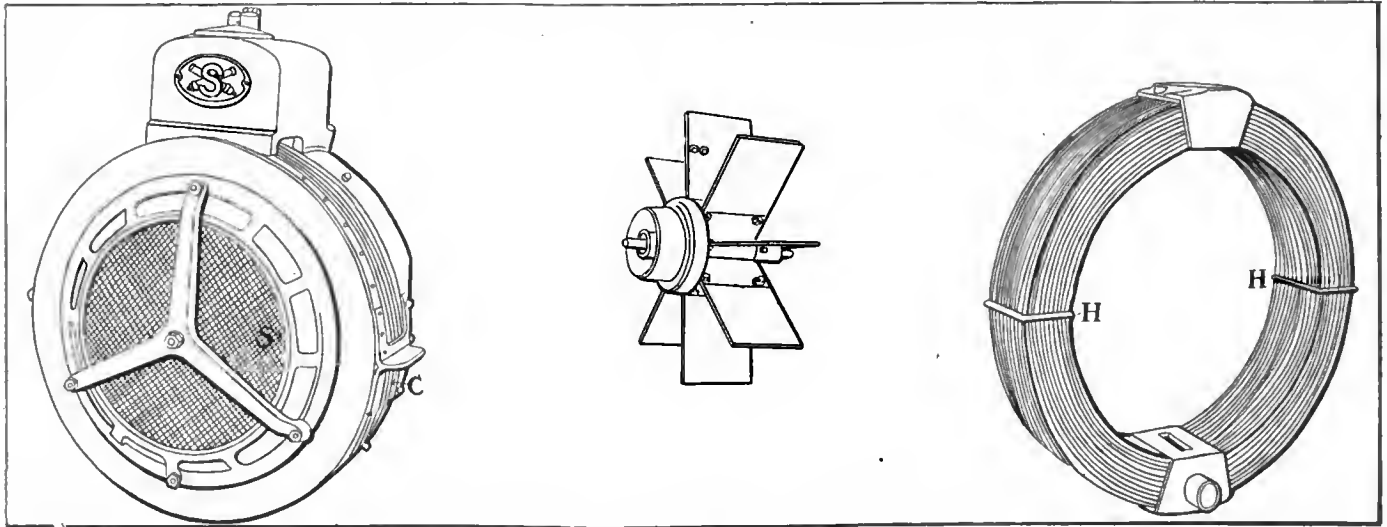

Fig. 1—General view of Solex radiator equipped with centrifugal blower Fig. 2—The centrifugal fan. Fig. 3—Nest of smooth copper tubes in forced draft radiator adopted for all Paris omnibuses

THE principle of the centrifugal blower which has been applied for several years in

the United States in connection with air-cooled motors, such as the Frayer-Miller and the Franklin, has been adopted in connection with water cooling and a special radiator constructed for all the vehicles controlled by the General Omnibus Company, of Paris, after extensive competitive trials. The radiator in question, called the Solex, is the same that has been used for some time on Schneider and De Dion buses and the appearance of which is familiar to Parisians and visitors to Paris. One of the principal objects aimed for in the construction of this radiator is robustness, considering that the honeycomb radiator has been found too frail for withstanding the vibrations to which a radiator is exposed on commercial trucks and buses running on solid tires. The efficiency of the centrifugal blower, which is rated as five to six times higher than that of the ordinary automobile fan, gives the opportunity for combining the desired strength of construction, as well as low cost of production, with a correct and efficient system for regulating the temperature of the cooling water independently of the vehicle speed and somewhat in accordance with the variable heat generation of the motor. The fundamental idea of the designers seems to have been the simple and obvious one that if the positive-acting centrifugal blower is capable of improving the regulation of air-cooled engines, though it is difficult to lead the air currents so that they will absorb heat equally from all those parts of the cylinder surfaces which are in equal need of cooling, it should be doubly advantageous in connection with a radiator, if the latter is specially built with a view to giving the air currents unhindered passage over the surfaces to be cooled, at all motor and fan speeds. In the ordinary radiator, with a thrust or suction fan placed behind it, the resistance to the passage of the air over the water conduits is increased very much at high fan speeds through the formation of eddies due partly to the tubular shape of the air channels and partly to the irregular relations between the air currents and the air passages. The accompanying illustrations show the simple mechanical arrangement in the new radiator design by which these shortcomings in ordinary cooling methods have been avoided.

The ventilating fan, Fig. 2, is placed in the interior of a nest of copper tubes, Fig. 3, two bundles, H and Hr, of these tubes being

## Forced-Draft Radiator

bent in half circles and gathered into a collector B for the hot water at the top and another collector C for the cooled water at the bottom. The centrifugal fan F draws the air in through the opening around its axis and throws it out around the whole periphery, and in between the smooth copper tubes which are suitably spaced apart to allow the air to pass. The central air intake is protected by a screen S, Fig. 1, to reduce the quantity of gross impurities which a centrifugal fan is liable to draw from the atmosphere, and it is noticed that the arrangement of the tubes, in conjunction with their smooth surfaces, renders it easy to clean the cooling surfaces of whatever foreign substances may find lodgment there. The curved conformation of the tubes allows them to yield under the influence of vibrations or flexions of the chassis without straining the joints with the bronze collectors. The whole nest of tubes is protected against injury from the outside by means of a sheet metal casing, being secured to this casing by two bolts which pass through tubular channels in the collectors, still leaving the nest of tubes free to accept deformations, and the casing is mounted upon the chassis by suitable steel brackets. At the center of the casing a shaft is supported in front by means of an aluminum spider and at the rear in a steel bracket, and upon this shaft the fan revolves mounted upon two ball bearings more than 10 inches apart.

On top of the upper collector B there is mounted an aluminum tank T holding about 2 gallons of water, for a motor of about 30 horsepower, but the hot water from the cylinders is discharged into the collector. The author of the article mentions that this forced draft radiator was in use upon the Lefebvre tractor at the recent trials of self-propelled agricultural machines at Roubaix and Laon and proved to be the only one providing sufficient cooling for the hard-worked engines on those occasions.—*La Vie Automobile*.

**OXY-GASOLINE FLAME FOR WELDING AND SOLDERING.**—According to a somewhat indefinite report, gasoline, benzol, kerosene or alcohol may handily be used in the place of acetylene gas for autogenous welding or for soft soldering. To this end, the oxygen generator is simply connected by pipe or hose with a tank containing one of the fluids mentioned, and from it the gas mixture is piped under pressure to the burner, where, the report



# Automobile Metallurgy Made Easy

By E. F. LAKE

## Part VI

### Bessemer Steel — Its Manufacture, Physical Qualities and Chemical Composition

(NEXT WEEK—OPEN-HEARTH STEEL)



Large quantities of steel are turned out by the Bessemer process; in fact, a much larger tonnage of steel is turned out by the Bessemer process than by all of the other processes with which steel is made. In making steel this way the iron ore is melted in a furnace and what is known as cast iron is taken out of a tap hole at the bottom of the furnace and run into clay-lined ladles on car trucks. These ladle-cars are run to the Bessemer converters, Fig. 1, and the molten metal poured into them. The residue from the iron ore is called slag and being lighter than iron, it floats on the top of the molten metal in the ore furnace. This slag is drawn from the furnace through another tap hole that is located higher up.

The difference between the various iron products is that cast iron usually contains from 3 1-2 to 4 1-2 per cent. of carbon and the others less than this. After the percentage of carbon has passed 0.90 it will not thoroughly dissolve in the iron and separation begins. Above this percentage some of the carbon segregates in the iron in the form of graphite. This separation and formation of graphitic carbon usually becomes quite pronounced when 2 per cent. of carbon has been reached. Divisions are thus usually made on the following basis: Iron products containing over 2 per cent. of carbon are classed as cast iron; those containing between 0.10 and 2.00 per cent. are called steel and those with a carbon content below 0.10 per cent. are called wrought iron. When the carbon is below 0.30 per cent. steel is soft and cannot be hardened enough to prevent its being cut with a file. It is then called machinery, soft or low carbon steel. When the carbon content is between 0.30 and 2.00 per cent. a steel can be hardened enough to enable it to cut other steels. It is then termed half hard, hard, tool or high carbon steel.

Thus the molten cast iron when poured into the Bessemer converters contains a large amount of graphitic carbon which has to be removed to make it into steel. To get this carbon out air is forced through passages opening into the bottom of the Bessemer converter, Fig. 2. The air passing up through the molten metal causes it to boil and oxidize out all of the silicon and manganese and most of the carbon. After these have been burned out of the molten metal enough more is then added to give the finished steel the properties that are desired, this being the easiest way of controlling the amount. When this has been done the converter is tipped over, as shown to the right in Fig. 2, and the steel poured into ingot molds, from which it is taken to be rolled, hammered, pressed or forged into the desired shapes.

This is the simplest process by which steels are made and consequently they are the cheapest steels that are obtainable. Most of the railroad rails and structural steel shapes are made by this process, the cast ingots being taken directly from the



Fig. 1—Bessemer converters during the blow and when the steel has been poured out. On the left can be seen the converter from which the molten steel has been poured while that on the right was "blowing" when the photographer snapped his camera.

converter to soaking pits. In these they are soaked in heat until they arrive at the correct temperature for rolling, when they are rolled into the desired shapes. All kinds and shapes of bar steel, wire, etc., are also made by this process and sold in the open market.

The ordinary carbon steels, with any percentage of silicon, manganese and carbon that is desired, can be made in the Bessemer converters, but impurities such as sulphur and phosphorus cannot be reduced to as low percentages as when other methods are employed in making steel. Then, again, the air passing up through the molten metal causes it to absorb considerable quantities of oxygen, hydrogen and nitrogen, either in the form of occluded gases or in large enough segregations to form blowholes. Steels made by the other processes do not absorb the gases in such large amounts and they are, therefore, denser, tougher, stronger, etc., than those made by the Bessemer process. Thus, while Bessemer steel is the cheapest steel obtainable, it does not have the tensile strength or other mechanical properties that steels do which are made by other processes.

In the manufacture of steel rails titanium has been added to the molten metal as it is poured from the Bessemer converter into a ladle, and it almost entirely removes the occluded or segregated gases mentioned above. It thus adds to the strength and wearing qualities of the metal. Railroad rails, which are subjected to the frictional wear of car wheel flanges as they roll over them, have been made to last four times as long as the ordinary Bessemer steel, and especially when used on sharp curves where this frictional wear is very high. The increase in cost of treating steel in this manner has been made considerably less than \$2.00 per ton.

This would indicate that gears, frictional clutches, shafts, brakes and some other automobile parts might have a greater resistance to frictional wear and be tougher if titanium were added to the metal. They might even be made from a titanium-treated Bessemer steel. For such important parts, however, it would be better to use the titanium in steels made by other processes as such injurious elements as phosphorus and sulphur could be reduced to lower percentages. The difference in cost between Bessemer steel and that made by the next best process is but the fraction of a cent per pound on some grades and hence it hardly pays to use it for automobile parts.

Such parts as the brackets that hold the steps to the frame, pedals, change-gear lever, hood retainers and others that do not have any particular strains put upon them can be made from Bessemer steel without weakening the car. Many times such parts are made of brass or bronze for ornamental purposes, and Bessemer steel is much stronger than these. Its price is so much cheaper that it can profitably be used on the cheaper cars. The frame, brake bands, frictional clutch discs and similar parts that require considerable resistance to strains and frictional wear have been made from ordinary Bessemer steel even though they should have been made from a better grade. Many times dishonest dealers sell Bessemer steels for those made by more expensive processes, or they mix Bessemer and open-hearth steels together to enlarge their profit. This, however, is a subject that must be taken care of by the buyers, as it is difficult to tell one from the other.

As a general rule, Bessemer steel should not be used in any part of a motor car, although the titanium-treated Bessemer steels might give good results when used for certain parts, and ordinary Bessemer steel for parts that are not important, when cheapness is a factor.

The high strengths that can be obtained in steels made by other processes cannot be given to those made in the Bessemer converter. Any gases present are bound to lodge between various molecules of the mass and separate them so they cannot cling together. This entirely destroys the cohesive force at that point, and consequently lessens it in the whole mass. It is difficult to obtain Bessemer steels with a tensile strength of 125,000 pounds per square inch or an elastic limit of 100,000 pounds. Another reason for this aside from that given above, is that most

Bessemer steels have a low percentage of carbon, the higher carbon steels usually being made by other processes.

Carbon greatly alters the tensile strength of steel when it is properly heat-treated and the impurities reduced to a minimum. As an instance of this it is very difficult to show a tensile strength above 100,000 pounds per square inch with a steel that contains less than 0.20 per cent. of carbon, while the elastic limit of such a steel runs from 60,000 to 80,000 pounds per square inch. Give a steel, however, 0.50 per cent. of carbon, reduce the impurities to a minimum and properly harden it and the tensile strength can be raised to 250,000 pounds per square inch and the elastic limit to 230,000 pounds. Thus, a difference of three-tenths of 1 per cent. of carbon, or less than one-three-hundredths of the mass in which it is placed, will increase the tensile strength 150,000 pounds, or make it 2 1/2 times the strength of the lower carbon steel. This is out of all proportion to its volume and one of the wonders of metallurgy.

Such high strengths, however, are not obtained in Bessemer steels, as the impurities are not removed to the extent that they should be. The ordinary Bessemer steels, such as are produced for structural shapes and railroad rails, have a tensile strength of about 115,000 pounds per square inch and an elastic limit of 80,000 pounds. The addition of titanium to this steel for the manufacture of rails has raised this tensile strength to nearly 125,000 pounds per square inch and the elastic limit to over 95,000 pounds. To expect more strength than this from Bessemer steels is expecting what is rarely obtained.

### Honorary Kinks in Aviation Language

The French War Department has decided that hereafter every aeroplane found suitable to represent the French colors in military pursuits shall be known as an "*avion*" and that the first special weapon to be devised and found of signal value for use from "*avions*" shall be termed an "*ader*," both terms being accepted as common nouns. These new names are in honor of Clément Ader, whose book *L'Aviation Militaire*, though written long before the triumph of the Wrights, reads like a prophecy, and whose aeroplane, actually built and tried at the same date and which was called *L'Avion* by its maker, would have flown if the science of motor building had been more advanced.

Following upon the official authorization of the new term "*avion*," it is at once proposed in *L'Auto* to adopt "*avie*," as the verb meaning "to fly" instead of "*voler*" whose double meaning, "to steal" as well as "to fly," is inconvenient. The conjugation of "*avie*" would bring about some new linguistic collisions, however. "*J'avie*" does not sound good for "I fly" and "*nous avions*" for "we fly" caroms with "*nous avions*," "we had." Probably "*avie*" will have to be turned into an irregular verb, as irregular in its form as in its connotation.

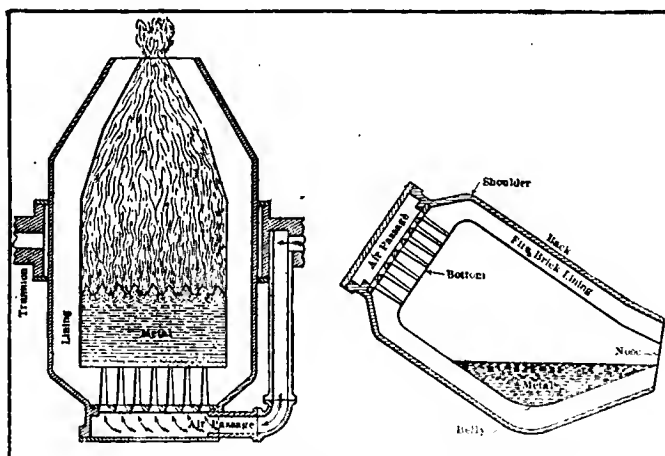

Fig. 2—Upright and tilted Bessemer converter



# Letters Answered and Discussed

## Brake Adjustment

EDITOR THE AUTOMOBILE:

[2,967]—The brake on my car will not hold very well when I apply it and I have to use the emergency brake continually. There is no turnbuckle on the car, but instead a sort of half turnbuckle which connects to the arm as in Fig. 1. How may I adjust the brake?

Pittsburgh, Pa. HARRY BINKS.

If you will take off the fitting you term a half turnbuckle and insert a screwdriver

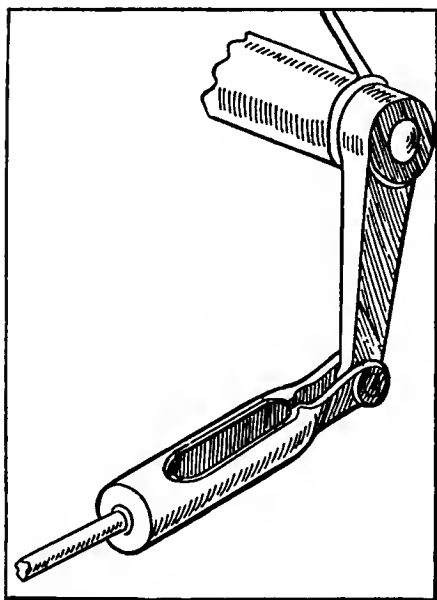

Fig. 1—Brake adjustment fitting in use which is not accessible

as shown in Fig. 4 you will be able to turn it over and tighten up on the adjustment. While at the work it may be well to have a fitting such as is shown in Fig. 2 installed by a repairman who possibly will have sufficient spare parts on hand to put in place. This is a much more accessible means of making the adjustment, the other being antiquated.

## Both Are Harmless

EDITOR THE AUTOMOBILE:

[2,968]—Will you please give me your opinion on the following through the pages of THE AUTOMOBILE:

(1) I am the owner of a four-cycle four-cylinder touring car equipped with a dual ignition system consisting of a dry battery set and Splitdorf magneto. The motor has one set of spark plugs. For the past month the dry battery set has been dead and I have been running entirely on

The Editor invites subscribers to communicate their automobile troubles and personal experiences, stating them clearly on one side of the paper. If the nature of the case permits, send a sketch, even if it be rough, in order to assist to a clearer understanding. Each communication will receive attention in the order of its receipt, if the writer's signature and address accompany it as an evidence of good faith. If the writer objects to the publication of his name, he may add a nom de plume.

the magneto. Will this cause any undue strain on the motor or ignition system? I have no trouble in starting as the motor generally starts on the first turn and never kicks back.

(2) In order to prevent freezing over night I always draw the water from the radiator when I put the car in the garage and while the water is still hot. At the same time I let the steam out of the radiator by removing the cap from the top. Is this likely to harm the motor?

Spokane, Wash. INQUIRER.

(1) This will not harm your motor in the least. Care should be exercised, however, that you do not unexpectedly get a kick back.

(2) This will not harm the motor.

## Wants Tire Facts

EDITOR THE AUTOMOBILE:

[2,969]—I think a matter of interest to car owners would be a few comments and figures on the use of larger size tires than are the regular equipment on some stock cars. For instance, one car advertised to weigh 2250 pounds was fitted with 32 x 3½ inch tires and really weighed 2450 pounds. The tires supplied called for a pressure of 80 pounds. Almost all other tires of the same size call for a pressure of only 70 pounds. Are the above tires sufficient to carry a loaded 5-passenger car? Would an actual saving in tire expense result if 33 x 4 inch tires were used at an additional cost of approximately \$15 per tire? Does a smaller diameter tire on a front wheel cut easier than a larger size.

Pittsfield, N. H. WILLIAM B. ELY.

A 3½ inch tire should never carry more than 600 pounds. In a car weighing 2450 pounds, with the addition of five passengers, each weighing 150 pounds, each tire would be called on to bear a weight of about 800 pounds. The tire you speak of would hence be greatly overloaded. With the 33 x 4 inch tire the load would still be too great and the car would be undertired. The correct tire to use in this case would be a 34 x 4½. A smaller tire would be apt to be cut more rapidly than a larger one.

## Qui Sait ?

EDITOR THE AUTOMOBILE:

[2,970]—The announcement of H. E. Coffin's address before the English Engineers brings to my recollection the remarks of an English correspondent of *Auto-Car*, London. This gentleman, in writing the account of the last Madison Square Garden Auto Show, has the following to say, as published in *Auto-Car* January 28, 1911, over the initial "N:"

"My impression is that cleanness of design is not a characteristic of American cars. Only two manufacturers showed cars which left nothing to be desired in this respect."

These remarks are particularly timely in connection with Mr. Coffin's address on clean chassis design.

You may publish this, if you wish, but my chief object is to ascertain the names of the two manufacturers referred to.

CHRISTOPHER LIPPS.

Baltimore, Md.

## Tips from a Repairman

EDITOR THE AUTOMOBILE:

[2,971]—Gentlemen: In the number of December 7 I read the inquiries from the following subscribers, and having had quite a good deal of experience as repairman, etc., I would add this to your answers, if you care to publish them:

[2,939]—M. E. Long.—The trouble you speak of can be remedied by gas bags, at a

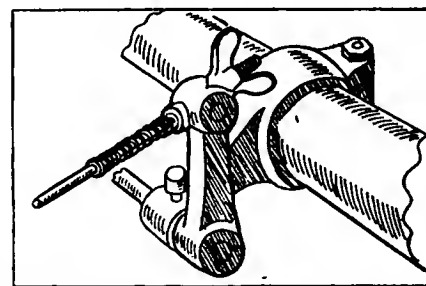

Fig. 2—Modern form of brake adjustment which may be installed with spare parts

cost of 25 cents each, to go between end of gas line and lamps. These will not only collect the water, but have the advantage of giving you practically an even pressure of gas at the burner, as they compensate to a large extent for the change of flow of gas from the generator caused by varying road conditions. They are easily cleaned and do not clog.

[2,943]—J. R. Day.—If you will take out the screw block in your drag link, and the spring, you will find two concave blocks

that fit about the ball on the steering arm. Take these out and fit them around the ball and see if their edges do not come together and still leave some shape. Grind down the edges until there is a space of about 1/16" between edges when fitted around ball. You will find, I think, that that remedies your trouble.

[2944]—C. J. Andrews.—If there is no drain cock on the bottom of your radiator look for a pipe plug. All radiators have some provision for drawing off water. Also look for plug under water jacket and

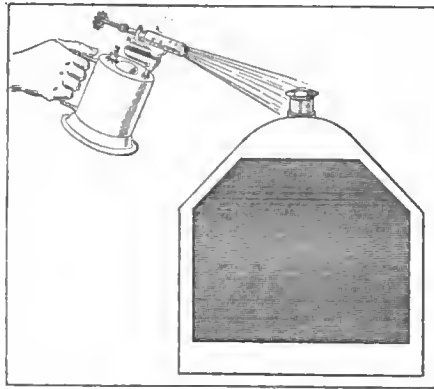

Fig. 3—Method of removing radiator cap by gentle heating with torch

between cylinders, if yours is a vertical motor, cast in pairs. If there seems to be no other way loosen hose clamp and pull hose off bottom of radiator.

New Haven, Conn. W. B. UTLEY.

### Speaks from Experience

Editor THE AUTOMOBILE:

[2972]—Referring to letter No. 2953, signed by Mr. H. L. Shepard of Rochester, N. Y., relating to trouble with his headlights on Ford car, I think that if Mr. Shepard will set his vibrators as light as possible that he will have no trouble with his magneto operating his car and lights at the same time. I have found several cases similar to his and the vibrators were screwed up so tight that the magneto could hardly operate the vibrators alone, to say nothing about lighting the lights at the same time. The vibrators should be loosened up just as much as possible and have the car run. then give them a slight turn to stiffen them up a little, sufficient to operate the car at high speed, then I think he will have no more trouble in this direction.

I do not find that the valve stems need readjustment as the wear on the valves and the grinding takes up any wear on the end of the valve stem.

Watertown, N. Y. C. D. WARNER.

### Radiator Cap Stuck

Editor THE AUTOMOBILE:

[2973]—Every time I desire to remove the radiator cap in order to replenish the supply of water before starting out I have trouble in removing the cap from the

radiator. I have been hammering it lately, but do not wish to continue this as I am spoiling its appearance.

TROUBLED.

New Haven, Conn.

If you have a torch in the garage it could be lighted and then applied to the radiator cap in the manner shown in Fig. 3. Since the heat reaches the cap first it will expand before the metal upon which it is fitted. In this way you will find that it may generally be removed.

### Has Trouble with Single Cylinder

Editor THE AUTOMOBILE:

[2974]—I have a single-cylinder car with which I am having all kinds of trouble. I cannot get an explosion strong enough to give one turn. The ignition system is all right as I have a good coil and get a good hot spark. The timing also appears all right, but I do not get an explosion even when I prime the motor.

M. M. J.

Salem, Mass.

Your troubles may be due to a variety of troubles and the symptoms described are not detailed enough to accurately determine their exact nature. However, the seat of trouble may lie in the fact that the compression is not good. This would most likely be the case if the motor were old. If it is a new motor, since the ignition is as it should be, the cause of the trouble may be found in a faulty carbureter adjustment.

### Compressed Air Starter

Editor THE AUTOMOBILE:

[2975]—(1) Would it be practical to use compressed air in an automobile using a gasoline engine to compress the air, superheating by means of the exhaust, and utilizing a double-acting engine for the final drive? Such an arrangement it would seem would give the utmost flexibility provided the losses are not too great.

(2) I would also ask if a two-cycle engine is constructed with a sliding sleeve valve admitting the charge of gasoline at the head of cylinder instead of through a port at the end of piston stroke?

It would seem that such a construction would make a very satisfactory motor, provided the charge is admitted through four ports on opposite sides of the cylinder simultaneously so that the currents of air entering the cylinder would impinge on each other in such a manner that the new charge would be more thoroughly diffused throughout the combustion space, and a more thorough scavenging result.

(3) Has any method of scavenging a two-cycle motor ever been put to practical use?

MEDICO.

Grafton, W. Va.

(1) It would not be practicable, for even if such an outfit could be made to run satisfactorily it would have to have a 100 per cent. efficiency in order to derive

as much power from the air as would be given up by the compressors of the gasoline motor, so that the motor would have to have the same horsepower as those now in use. Added to this motor would be the extra weight of the air and double-acting engine outfit which would make the whole plant too large and heavy for any self-propelled road vehicle.

(2) The complications of the manifolds necessary to carry out this scheme would more than overbalance any good which could possibly result from its use.

(3) Only in some of the larger double-acting types, such as the Koerting motors where an auxiliary air tank was employed to allow air to flow in under pressure and expel the dead gases.

### What Is a Second-Hand Car?

Editor THE AUTOMOBILE:

[2976]—You would oblige us very much by giving us a clear and concise definition of new car, demonstrator, and second-

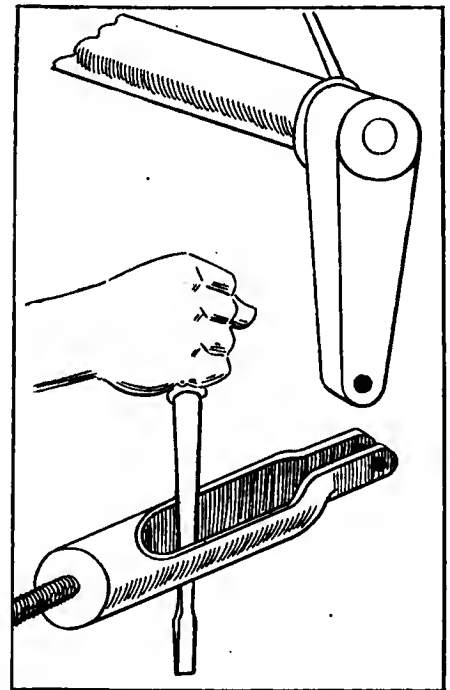

Fig. 4—Method of adjusting the old-fashioned brake fitting

hand car. We have been having some controversy about this subject.

One of the parties contends that a car which has been used only a short time and only for demonstrating purposes is still a second-hand machine. I think that a car cannot be called second-hand until it has been sold by an agent to an individual and then offered by him for sale the following season.

BERLEW & SUNDERLAND.

Any car which has been in active use, whether for demonstrating purposes or not, cannot be called a new car. The number of miles that the car has been driven generally determines its value. Anything not new is second-hand.

# Little Bits of Motor Wisdom

## Pertinent Pointers for Repairman and Driver

**U**NDERSTAND YOUR LUBRICATING SYSTEM.—There are very few general forms of lubrication in use at the present day so that a general understanding of the principles in use in each would aid materially in giving the average motorist the general lines along which to follow should he investigate the oiling system on his new car or, in case he has neglected this important feature in his old car, to turn over a new leaf and become familiar with those principles upon which the life of the car depends to a large extent. The damage done to cars owing to the neglect of the cylinder and other lubrication far exceeds any other damage in its far reaching results. The cost of making repairs when the damage has been caused through neglected oiling of a given part is only equaled by the amount of money paid over for such damages as are caused by collision and other varieties of wreck.

Every motor car owner should understand the lubrication of his car before he takes it upon the road for the first time. If the owner does not care to drive but turns that part of the pleasure over to the chauffeur, it is upon the latter that the duty of keeping the repair bills as low as possible will fall and upon whom the life of the car depends. The general principles may be readily grasped by the average business man since they are merely a product of common sense and do not involve any dark and mysterious mechanical secrets.

The first system which may be considered since it is found to a great extent upon the cars in use today is what may be called the circulating splash system. This

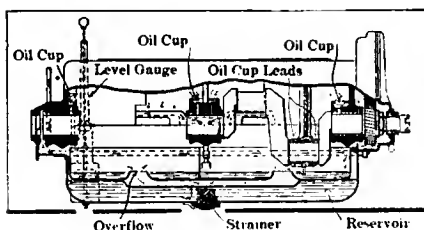

Fig. 1—Depicting the oil cups and troughs for National splash system

system is also generally known as the constant level splash system and is perhaps the cheapest system possible to install upon a car and at the same time maintain an efficient lubrication at all times. When this system is used the crankcase of the motor is generally a very deep casting in which the lower part forms the reservoir and is

capable of carrying anywhere from 3 to 7 quarts of oil. The reservoir or base chamber generally slopes toward the rear of the casting so that it is deeper at this end. At the lowest point a pump which may be of either the plunger or gear type is installed. For the benefit of those familiar with the details of these two types of pump it may be said that in the plunger type the oil is sucked into a cylinder by means of a piston or plunger and then upon the next succeeding stroke is forced through a lead pipe in the direction in which it is desired to carry the oil. The gear pump, which is more commonly used for oil circulating purposes owing to the fact that ball check valves which are prone to stick are to a large part eliminated, consists of two spur gears which intermesh. The oil is drawn between the rapidly revolving gears and squeezed up through the outlet lead.

From the pump the oil is either led directly to the splash chambers or in other cases it is led to the sight feed which is generally located on the dash. The oil pump is driven from the camshaft by means of gearing or from the magneto and water pump shaft through gearing or through a vertical shaft, the lower end of which carries the gear pump and the upper end carries the timer. When the oil pump is of the plunger type it is driven through a crank or eccentric since a reciprocating motion will have to be imparted to the plunger.

The oil lead from the pump, whether it passes through a sight feed on the dash or passes directly to the crankcase, supplies the oil directly to the troughs which form the basis of this system. These troughs are so arranged that the ends of the connecting-rods in their downward sweep pass into them for a depth of about 3-16 inch. One trough is placed beneath each connecting-rod and the main oil lead which takes the supply from the pump is so designed that it will keep the trough full under all conditions of travel. The troughs are carried upon a sort of horizontal partition or tray which separates them from the lower part of the base chamber which contains the reservoir.

The rapidly revolving connecting-rods sweep down into the troughs and churn the oil into a fine spray which will be found all over the entire crankcase. This spray penetrates the cylinders and is drawn up by the pistons and distributed by the rings over the cylinder walls. The cylinder walls are thus amply lubricated and the supply of lubricant constantly renewed

by the fresh supply drawn up by the pistons. The wrist pins are often made hollow so that there is a certain amount of oil which finds its way through the open ends; this will find its way through a duct which is cut through the upper connecting-rod bearing and hence lubricates the point. The lower connecting-rod bearings are generally lubricated by the scoop which is on the bottom of the connecting-rods. This scoop is hollow and permits the oil to flow through it and thence into the bearing. If there is no scoop fitted to the connecting-rod the bottom bearing cap is generally pierced by a hole through which the oil penetrates as the connecting-rods plunge into the troughs.

The camshaft and main bearings are

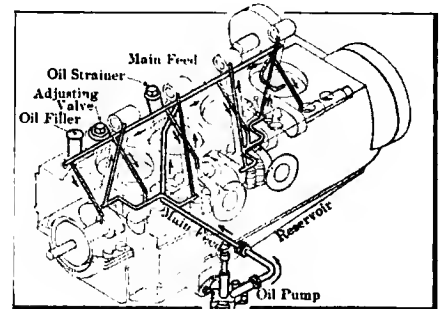

Fig. 2—Showing oil leads on the Knox cars using force-feed system

lubricated by the oil spray which will be very thick in the crankcase and will be found to reach every point in sufficient quantities to lubricate any part. In order that the supply to the main bearings will be constant, it is the custom of some manufacturers to place a small cup or pocket above them in which the oil will be caught and from which it will flow directly to the main bearings. The timing gears are often provided with either a pocket in the same manner as the main bearings or in other cases a separate lead is led to them from the pump and the oil allowed to flow into the casing and thence drain back to the troughs in the main part of the crankcase.

Since the oil is continually supplied to the crankcase in greater quantities than it is being used there would be an accumulation of oil above the troughs unless there was some means of draining it off. This is provided by a series of overflow pipes in some cases and in other cases it is provided by placing the overflow outlets in standpipes. The overflows in any case are so arranged that they will be at the correct height to take the oil away from the

upper part of the crankcase before it accumulates to such a height that there will be an oversupply of oil thrown up into the cylinders which would cause them to smoke. The overflows take the oil from that part of the crankcase which contains the troughs and leads it back to the lower part in which the reservoir is found.

In this manner the oil is used over and over again, for as soon as it reaches the crankcase it will again be drawn up by the pump and sent through the oil leads again, whereupon it will finally reach the crankcase after passing through the system. From time to time more oil will have to be added to the crankcase to replace that which is burnt up or is used in other ways. If there is a sight-feed on the dash the condition of the oil will be known to the operator by his observation of the supply passing through the glass. It is necessary that the supply be renewed in the crankcase once every month. When this is done the old supply will have to be cleaned out and the crankcase flushed out with kerosene. It is a good plan to allow the motor to turn over for about 3 seconds with kerosene in the base so that the old oil

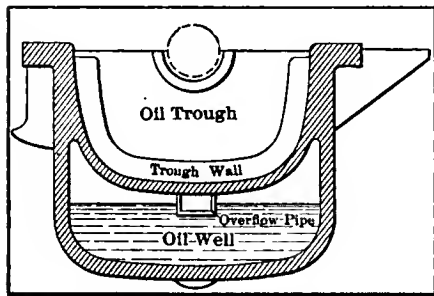

Fig. 3—Form of transverse section through crankcase of splash lubricated motor

will be flushed from the pump. The screen which is placed in the circulation line and through which all oil that enters the pump must pass should also be well cleaned out or else its purpose will be defeated owing to the accumulation of dirt which will eventually be forced through the meshes of the screen. Small details may vary on cars of different makes, but this is a general view of the splash system.

**COMBINATION FORCE-FEED AND SPLASH.**—This system will be found to vary very slightly from the purely splash system. The oil is generally carried in the lower part of the crankcase in the same manner as that described for the splash system. The pump is placed in a similar manner, but the oil instead of being led to the splash troughs directly is led to the main bearings through independent leads. A sight-feed is placed on the dash in some makes of cars and when this is done the type used may be either one which will show the flow to each main bearing or it may on the other hand consist of a single glass which indicates the flow as a whole.

The oil will flow to the main bearings under the pressure given by the pump. The lubrication of these bearings will hence be positive and the same under all circumstances. The oil then passes from the bearings into the troughs on either side and is picked up by the connecting-rods and thrown up into the cylinders in the same manner as described for the splash system. Overflow pipes are provided so that the oil will pass back to the reservoir from where it is picked up again by the pump after passing through the screen and thence goes through the system again.

The same precautions will be necessary in cleaning the crankcase every month in order to insure a fresh supply of oil to the motor. The drain plugs in the bottom of the crankcase will have to be removed and the old oil allowed to flow out at least once a month or after every 500 miles. The kerosene is then introduced through the oil filler hole or through the breather pipe and the engine allowed to run in the same manner as above described.

It will be seen that the splash systems and the combination do not vary to any great extent. Occasionally, however, a combination system will be found in which the oil is not only fed to the main bearings but from there passes through a hollow crankshaft to the other bearings, and occasionally up a lead along the connecting rod to the wrist pin bearing. In this case the only parts of the mechanism which are lubricated by the splash are the pistons and the camshaft bearings. The system is on the whole more of a force-feed type than a splash.

**THE FORCE-FEED SYSTEM.**—When this is used the reservoir may either be in the base of the motor or not, according to the method used. If the oil is recirculated the reservoir will be in the base, if not the reservoir is independent of the motor and is generally in a small tank on the side of the crankcase, but is not an integral part of the same. The recirculating type may be considered, the two principles being the same. The crankcase is not subdivided by either horizontal partitions or by vertical troughs, as is the case in the splash system of lubrication. These partitions are not required because the connecting-rod does not splash into the oil in any case as this would cause the motor to smoke. A mechanical oiler is fitted which consists as a rule of a number of small plunger pumps mounted side by side and which are all operated from the same shaft which passes through the box and upon which a small crank is fitted for each pump. A lead runs from each of the pumps to some part of the motor, either the main bearings or other bearings throughout the mechanism, and the oil will be driven through these at a pressure which may be regulated and which will vary under the different conditions of use of the car. For city driving

a pressure of two pounds will be found sufficient for all cases, while in the country or for racing purposes the pressure required will be considerably in excess of this. A pressure gauge is often located on the dash in place of a sight-feed when this type of lubrication is used and the pressure on the gauge will drop when the supply of oil begins to diminish appreciably.

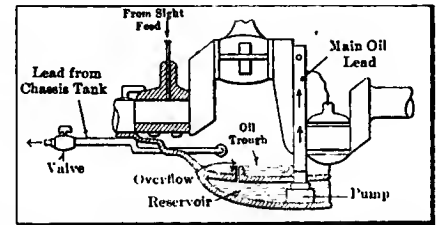

Fig. 4—Auxiliary tank used on the Royal Tourist cars with splash system

The crankshaft is made hollow and is drilled so that it will register with a similar drilled duct in the main bearing bushing. As the crankshaft turns about, there will be a quantity of oil forced into it at each revolution during the time that the two ducts are opposite each other. During the other part of the revolution the oil will flow into the main bearing itself and lubricate it. There will be a quantity of oil thus forced into the center of the crankshaft against the slight centrifugal force encountered upon entering the shaft. This oil will flow through the shaft until it reaches the crank cheeks, through which it will be thrown by centrifugal force owing to the large comparative radius of the same. The oil thus finds its way to the connecting-rod bearing. The connecting-rod is fitted with a small tube of copper, through which the oil is carried to the upper end and thus into the wrist pin bearing. Whenever the opening leading to wrist pin lead registers with the opening in the connecting-rod bearing bushing a stream of oil will be forced into the lead. This will gradually work its way to the wrist pin, which will be lubricated in this manner. The wrist pin is very often pierced by an oil hole so that the lubricant may flow through this member to the walls of the cylinder. The cylinder walls are also lubricated by the additional oil which is thrown upon them by the spray that leaves the bearings at the lower end of the connecting rod owing to the great centrifugal force at this point.

The oil flows back into the reservoir in the bottom of the crankcase and is then strained and drawn through the mechanical oiler again. The process of cleaning is carried out monthly in this system as in the splash and combination methods of oiling. The mechanical oiler should also be flushed out as well as the crankcase itself as the dirt and grit which will finally collect in any circulating system is apt to find its way into the oiler. The ball check valves in the mechanical oiler should be kept clean, as dirt stops the oil flow.

# My Ideal 1912 Automobile

## Readers' Conceptions of What Next Year's Car Should Be

### Experienced Driver's Views

Editor THE AUTOMOBILE:

**Y**OUR readers' conceptions of the ideal car interest me, and I should like to beg a little space in your valuable columns. I should like particularly to know if any of your readers are inclined to agree with me.

My views of the ideal car run thus: The motor should preferably be a six-cylinder four-cycle one, with the cylinders cast singly or in pairs. The bore should be 4 inches and the stroke  $5\frac{1}{2}$  or 6 inches (if a four-cylinder motor the bore should be  $4\frac{1}{2}$  inches and the stroke 6 inches). It should be water-cooled, copper water-jacketed, and the circulation should be maintained by means of a gear-driven centrifugal pump. There should be a tubular radiator with copper plates. The valves should be of the poppet type,  $2\frac{3}{8}$  inches in diameter, enclosed, and all on one side. The splash oiling system maintained by force-feed pump into the crankcase with sight-feed on the dash should be included. All bearings where possible should be provided with grease cups, and the ignition should be by Bosch magneto or dynamo which, through storage system, could also be used to start the car and to light it.

A Stromberg carbureter should be used or, possibly better, an individually designed carbureter built for and adjusted to the engine and with provision for an air valve operated from the driver's seat for use when coasting on compression. The clutch should be a leather-faced cone of the Renault type, and a straight-line drive; one or two protected universal joints and an adequate torsion bar should also be included. The transmission should be optional, preferably of the selective sliding-gear type, with four speeds forward and reverse, direct drive to be on the third speed with a ratio of 3.3 to 1; fourth speed over direct and geared 1.7 or 2 to 1. Or if preferred it could be selective sliding with three speeds forward and reverse, direct on third and geared 3.3 to 1.

For my own driving on a car of such horsepower I should prefer the four-speed transmission, but for the standard cars I think the three-speed would be the better on account of the fact that most of the cars would probably be purchased by men as their first cars, making it possible that they would ask too much of the over-direct and would ignore it.

The frame should be a pressed channel section steel, thoroughly reinforced, with a drop at the dash line and a rise again at

*Readers continue to demonstrate their interest in the ideal car and the specifications which are submitted show a wide range of taste and requirements. In view of the interest shown the Editor continues to extend the invitation to all who entertain ideas on this absorbing topic, to submit their opinions for publication. The description should be legibly written on one side of the paper and signed by the sender, although if it is so desired the name will not be published.*

the rear axle to allow the body to hang low. The body should be straight line across the bonnet and doors, thus allowing plenty of height for the seat and lessening the unsightly high seat back above the top of the body line.

The steering column should have rake, this together with plenty of leg room in the front seat being the only things that will give comfort in touring. The steering wheel should be in the driver's lap, and not so far away as to necessitate reaching out or up for it. The spark and throttle levers should be on the steering wheel on a semi-circle, the same to pull toward the driver to open the throttle and to advance the spark. The drive should be right hand, with the gear control levers also on the right. If necessary, however, to keep the body narrow, these latter could be put in the center. The wheels carried should be 37 inches by  $4\frac{1}{2}$  inches or 38 inches by 5 inches, with quick detachable tires. The front axle should be of the ball-bearing type, I-beam section, while the rear axle should be a full-floating Timken. The brakes should be internal expanding and external contracting on the rear axles, the brake drums being 18 inches by  $2\frac{1}{2}$  inches.

The gasoline should preferably be fed by gravity, but if necessary to keep the body low pressure feed should be employed. A gasoline gauge should also be placed on the dash. The wheelbase should be from 124 to 130 inches. The car should be fully equipped with top, wind shield, speedometer, etc.

L. M. G.

Jersey Shore, Pa.

### Has Views of His Own

Editor THE AUTOMOBILE:

Perhaps I am a little late in expressing my views of the 1912 car, but I trust that you will see fit to publish them nevertheless.

As I do a great deal of driving regardless of the weather I would prefer a car having a little reserve power, say one with from 40 to 50 horsepower. The motor

should be of the improved water-cooled, six-cylinder type, and it should be a T-head affair. The valve springs should be inclosed in such a manner as to be easily accessible if need be. I would prefer that the cylinders be cast in pairs, as I am not very favorable to the monoblock construction. The Knight type of engine would be preferable, also, as it is the coming type on account of its noiselessness and smooth running. The size of the cylinders should be 4 inches by  $5\frac{1}{2}$  inches, and while this is not an extremely long stroke it seems to be amply long enough for proper fuel economy and for best power output at all loads.

The ignition should be by the Bosch dual system, which system should also be used to light the headlights. The lubrication should be by a combined splash and force-feed system, and it should be so designed as to positively force the oil to the cylinder walls and the bearings. Small scoops should be fitted to the crank ends of the connecting-rods to dip oil from the reservoir. The clutch should be a multiple disk one, with 61 plates running in oil. The housing for this should be so constructed as to prevent any leakage of oil.

The transmission should be of the selective type and there should be three speeds forward and a reverse. The drive should be by shaft, and there should be two universal joints included.

Semi-elliptic springs should be used on front and rear, and the rear axle should be floating. A B. & L. Castor front axle seems very desirable to me, as I have seen to my satisfaction that it reduces vibration and makes steering much easier, especially over rough roads. A wheelbase around 140 inches seems about the correct thing to me, as it allows ample seat room and leg room. Tires to carry should be 36 inches by  $4\frac{1}{2}$  inches.

The control should be in the center of the car, since this makes for simple chassis construction, as well as making it easier for the driver to get into his seat. The steering wheel should be on the right, and it should have mounted on it the usual spark and throttle levers. The body should have ample seat room for five passengers.

I would specify the usual equipment of speedometer, lamps, horn (Klaxon), compressed air self-starter, two extra quick-detachable tires, robe rail, tire irons, waterproof top, windshield, gasoline gauge on dash, clock, trunk rack, etc.

Possibly the price of this car would run up to as high as \$5,000, but I think it would be worth the money.

K. L. S.  
Washington, D. C.



# Oxy-Acetylene Welding and Cutting

WHILE the oxy-acetylene flame, by reason of its manageability and intense heat, has proved exceedingly convenient for the performance of welding and metal-cutting operations, even such as a short time ago were beyond the resources of an ordinary machine shop or factory, an exaggerated idea of the simplicity of the equipment required for the production and utilization of this gas mixture has resulted in an influx upon the markets, in most industrial countries, of many troublesome apparatuses, which are usually offered at a tempting price, as sufficient for all needs. As an offset to this condition, some of the technical publications in Europe are now furnishing descriptions and explanations of good practice in this new branch of work, and, while the descriptions are perhaps in no instance completely up to date—since new developments appear from day to day—they illustrate the technical requirements of the work and enable the readers to steer clear of devices in whose design, materials and workmanship there is no evidence to show that the makers have investigated anything but the vogue of this class of apparatus.

Some extracts with illustrations from German articles of this kind are presented in the following, though it may be noted that the German writers agree on recognizing superiority in the British practice so far as the hand tools are concerned which are employed for the work.

**WELDING**—A welding tool which was first shown at the British Olympia exhibition one year ago and which has been found convenient and durable is represented in Fig. 1, including a sectional and a top view and two detail sections. The two inlet pipes, a for oxygen and b for acetylene, are connected with the gas generators or tanks. The oxygen passes through the control valve c and the tube d to the injector nozzle e, issuing from which it mixes with the fuel gas coming by way of the cock f and the tube g. The now united gases, whose quantities can be accurately regulated at c and f, are carried out into the expansion space h which extends from the bent mouthpiece i into the copper discharge nozzle k. By virtue of the oblique position of the mouthpiece, the tool can be placed in any angular relation to the work, from 0 to 70 degrees, without interruption of the flame. By loosening the knurled nut l, the mouthpiece can simply be turned around to the desired position. This is especially of value if the work cannot so readily be turned around.

Many universal welding tools, intended to be operated with different mouthpieces according to the requirements of the work, are offered in the market, but the frequent exchange of mouthpiece soon affects the screwthreading, and in some of them back-firing is liable to occur, the flame striking back into the mouthpiece and continuing to burn, so that the welding is interrupted and often spoiled, while the tool must be cooled before it can be used again. Even if an accurate adjustment of the oxygen supply is possible in a universal burner of the kind referred to, more skill is required as well as more time for making the adjustment correctly than if a special tool, intended for only one mouthpiece and a limited range of gas adjustment, is used. Considering the influence upon the work of unsuitable adjustment and the fact that the oxygen is the most expensive material used in the process, and that this material is wasted if the regulation of its feed is in any manner rendered difficult or inconvenient, it is not surprising that the best practice runs to the use of complete special tools for each kind of work which may be required in a shop. In this connection it is notable, too, that the different metals on which work is done naturally requires different quantities of gas for maintaining the heat required in each case over a given area of welding surface.

Among German advertisements are noticed some in which bottled and compressed oxygen is offered the trade for welding purposes, the bottles being either sold or rented, while on the other hand the acetylene gas is usually produced in generators which form part of the welding plants as they are offered for sale. These generators may be classified in four types, which, however, are of very unequal value in furthering and safeguarding the work for which they are intended. Only the system by which the calcium carbide is automatically fed in small quantities to a large volume of water can be considered as advantageous. The feed is adjustable, and the gas is generated only in small quantities corresponding to the demands of the work in hand. It therefore remains cool. The gas as fast as produced gathers under a floating bell. No after-development of gas takes place. The generator is always ready for new work without other preparation than the adjustment of the feed. In apparatus of this type the principal thing to look out for is that it includes no ropes, rollers, springs, valves, levers, cogwheels, stuffing boxes and rubber packings, but only water joints. The size of the carbide used should not be less than 10 millimeters (1-2 inch). Apparatuses with feed cocks and tubes or hose always

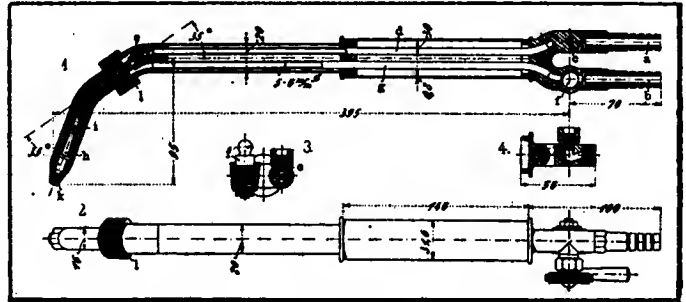

Fig. 1—Autogenous welding tool—dimensions in millimeters

require fine-grained carbide which remains in part dry on top of the water surface upon which it falls.

A variety of this type in which all the carbide required for the contemplated work is thrown into the water at once requires a large water reservoir to keep the gas cool and a large gas bell. It is lacking in compactness and calls for skilled judgment in estimating the carbide required, if interruption of the work is to be avoided.

The other systems represented in the market are the dipping system by which the carbide container is submerged in the water until a sufficient volume of gas has been generated and is then withdrawn; the expulsion system by which the water enters into two or more carbide containers from below and is expelled only by the gas pressure developed above it, and the combined dipping and expulsion system which combines the disadvantages of the two previous ones. These relate mainly to the after-development of a gas, which is generated under heat and is not acetylene ( $C_2H_2$ ) but ethylene ( $C_2H_4$ ) and has a harmful influence on the quality of the work, and to the necessity for frequent readjustments which interfere seriously with both quality and output. A disagreeable odor in the shop, from escaping gas, should also be mentioned. These methods all waste carbide through insufficient wetting.

With all systems, a simple method for getting rid of the carbide sludge should be provided. The simplest is a drain through which the sludge is washed out with the water.

**CUTTING**—A metal-cutting tool is shown in Fig. 2, including two sectional views of the tool in its entirety and three details.

The working principle is that the oxygen, entering under pressure at S entrains the fuel gas in the required quantity, so that a good mixture of both gases flows under sufficient pressure into the burner nozzle. The valve through which the oxygen is admitted can be regulated in two ways; first, by the knurled knob a which turns the valve spindle b, secondly, when this method is preferable, by first screwing the spindle b home in the threaded passage provided in the handlever c and then operating b up or down by means of this handlever, and by this method it is possible to shut the oxygen completely off by a single movement.

The details of the mechanism may be followed on the drawings. The valve spindle b is normally held open by a spring e secured in the bottom of the distribution chamber by a screw cap and bearing against a packing which acts upon a boss at the end of the spindle. The gas channels i and k, respectively for fuel and oxygen, are both provided with regulation cocks, l and m, the latter affording a different regulation for the oxygen from that which the spindle b places at disposal, as will be readily understood from the following. The fuel gas passes through k to the chamber p, while the oxygen, passing through the two openings regulated by spindles m and b respectively, flows into the separate channels s and t and thence to the end apertures of nozzles d and n. The channel t carries the oxygen intended for burning metal away and is discharged through the central nozzle d directly upon the work, while the oxygen flowing through channel t and serving to generate heat for melting the metal is first mixed with the fuel gas coming through the passages in the enveloping tube w, the mixing taking place in

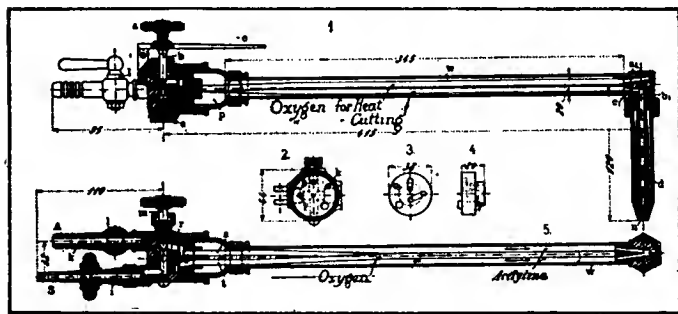

Fig. 2—Oxy-acetylene metal-cutting tool—dimensions in millimeters

the expansion space b1 in the back part of the mouthpiece a1 and flowing from here into the annular space between the nozzles d and n. In the interior of the distribution chamber o, a connecting block is inserted which leads the gases from i and k in the manner explained, as shown more definitely in the small detail sections of Fig. 2.

The special advantages of this tool are the convenience and accuracy of the gas flow regulation and the ease with which the mechanism can be taken apart and again assembled.—From *Der Praktische Maschinen-Konstrukteur*, October 12.

## Blackening Copper, Brass and Other Metals

With a pronounced tendency observable toward the avoidance of bright and shiny equipment for automobiles, the merits of various methods for imparting a black and permanent casting to the otherwise shiny parts naturally claim attention, and as it is a comparatively inexpensive process to copperplate most of the metals utilized for these parts the best means for blackening copper are considered in the first line. On this subject Bavarian Leaves of Industry and Trades (*Baye ische Industrie und Gewerbeblätter*), No. 43, offers information of a wet process with an alkaline solution which may be considered preferable to the well-known blackening process with nitrate of copper or nitric oxide and is more broadly applicable than the blue black etching process with an ammonia solution of copper which can be used only for alloys containing zinc.

The directions with regard to articles with a copper surface

are given as follows: A suitable quantity of a 5 per cent. lye of sodium carbonate (sal-soda) is heated to 100 degrees centigrade in a vessel of glass, porcelain, stoneware or enameled iron. Hereto is added 1 per cent. of powdered persulphate of potash, and the article is dipped in the bath suspended from a wire, so as not to touch the vessel. A visible generation of oxygen follows. The article is moved to and fro until the desired black color is obtained; in the case of small articles usually about five minutes. If the generation of oxygen is seen to lag or cease before this stage is reached, 1 per cent. of persulphate of potash must be again added. The velvety looking article is now rinsed in cold water and wiped dry with a soft cloth, acquiring a deep-black matt luster.

If the bath has not been exhausted and it is desired to use it again (with more persulphate of potash) it should be kept covered, so as to protect it against absorption of carbonic acid gas from the atmosphere.

Defective action, as may occur, may be due either to the lye or to the metallic surface. By continued use of the lye, the free alkali which is necessary for the action is neutralized by absorption of carbonic acid, or the alkaline bath is for other reasons deteriorated in course of time by generation and discharge of gas. In this case a new bath must be prepared.

Defects due to the condition of the metal surface are caused by thin films of oxide. It is best to prepare the metal by cleaning it in dilute sulphuric acid. Copper which has become tarnished by exposure or in a soldering process also accepts the etching process defectively. In contrast to the disturbing films of oxide, the brown coatings of protoxides obtained by the wet browning process accelerate the formation of black oxidation from the persulphate of potash bath, but the coatings formed on this foundation are somewhat less lustrous than those formed direct on metallic copper.

Zinc, tin, aluminum, iron, nickel, German silver, spelter and solder cannot be oxidized black by the persulphate of potash method, but some of the alloys of copper with these metals may be successfully treated. Those in which copper predominates, including the dark bronzes and gunmetal, accept the black coating like copper, but the process requires somewhat longer time, usually from five to ten minutes.

Brass and aluminum bronze require a bath in which the strength of the sodium carbonate bath has been raised from 5 per cent. to 10 per cent.

Pure or nearly pure aluminum is dissolved in the bath under a violent generation of oxygen.

Articles made of zinc may be blackened very successfully if previously copper-plated; but the copper coating must not be too thin, as a portion of it goes into solution in the bath. The electrolyte in which it is produced may, on the other hand, be either acid or basic. Copper articles in which there are seams of solder should also be plated first, as the solder will not accept the etching. And the plating is also the simplest method for removing the films of oxide which are usually formed on a soldered article and which would otherwise interfere with the blackening. To copper by dipping is not recommended, as the coat so formed is too thin and is usually also marred by spots of oxide which spoil the uniformity of the black coat.—From *Metall-Technik*, October 14.

**FIRM, CLEAN ALUMINUM CASTINGS.**—To get rid of the oxides which form on top of molten aluminum and get into the interior of the castings poured from it, the modern foundry man keeps a well stoppered bottle with chloride of zinc in pieces of about the size of a walnut, and when the aluminum reaches the fusion point, he picks out a piece with a tong—as the material attacks the skin—drops it into the molten mass and stirs the latter vigorously. Considerable smoke is developed by this process, but the bath becomes clean and mirror-like as molten tin, while the chloride gets black and floats to the edges of the crucible and the oxide turns into a powder which is simply brushed off before pouring.—From *Metall-Technik*, Oct. 28.

Waterproof Materials

In these modern days when serviceable substitutes for leather, varnishes and rubber are being sought by inventors, largely in connection with the production of articles intended for use in or with automobiles, the extensive application which has been found for casein is of interest. Mixed with soap and oils this substance is now much used for the sizing of textile goods. Four parts of casein with 30 parts of water and 1 part of chalk, mixed in a soap solution, make such a sizing, and if the fabric is subsequently plunged into a solution of acetate of aluminum, the casein is thereby rendered insoluble and the material can be washed in water and dried. The readiness with which the insolubility of the casein can be effected in any desired degree either by oxidation or by the action of formaldehyde is taken advantage of for producing materials which are to be permanently impermeable to water while admitting the passage of air.

Calicos and other materials which have always been prepared with albumen, derived from blood, to protect their colorings, are now in some cases treated with casein, which has proved cheaper, cleaner and better, and it is probably only a question of time before similar methods will be used for impregnating other fibrous material which should resist weather and water.—From *L'Industrie Textile*, August 15.

Production of Coal Tar

An inkling as to how far the actual production of coal tar will go in the improvement of roads may be had from British statistics on the subject. In 1889 there was an overproduction of the tar, and it was contemplated to turn it to use as fuel. Since then the tendency has been to reduce the tar production at the gas works, while the steel mills turn it out in ever increasing degree. The coal output of Great Britain rose to 263,774,000 tons in 1908. Out of this total 1,500,000 tons were used at the gas works. The total tar production was at the same time 1,100,000 tons, of which 750,000 tons came from the gas works, 150,000 tons from the coke ovens and 200,000 tons from the steel mills.—From *Bulletin of the Chemical Society*, II, 1911.

**LUMINOUS PAINT.**—By mixing pulverized phosphorescent material, such as sulfide of calcium, phosphoretted zinc or sulfide of barium, together with a trace of bismuth, with a binder material such as gelatine, lac, gelose, etc., a paint or gouache (water color body) is obtained which may be used for rendering any part of an automobile luminous in the dark, provided it has been exposed to the rays of light or heat previously. It may be varnished over or not, and it is not affected by rain or weather. The color may be any one desired. Georges Garfoukel has the French patent.—From *Chimie Industrielle*, September.

# Calendar of Coming Events

Shows

- Dec. 30-Jan. 6.....Buffalo, N. Y., Annual Show, Seventy-fourth Regiment Armory, Buffalo Automobile Trade Association.
- Jan. 2-11.....New York City, Hotel Astor, Importers' Salon.
- Jan. 6-13.....New York City, Madison Square Garden, Twelfth Annual Show, Pleasure Car Division, Automobile Board of Trade.
- Jan. 6-20.....New York City, Madison Square Garden, Annual Show, Motor and Accessory Manufacturers.
- Jan. 10-17.....New York City, Grand Central Palace, Twelfth Annual Show, National Association of Automobile Manufacturers; also Motor and Accessory Manufacturers.
- Jan. 13-19.....Milwaukee, Wis., Auditorium, Fourth Annual Show, Milwaukee Automobile Dealers' Association.
- Jan. 13-27.....Philadelphia, Annual Show, First and Third Regiment Armories, Philadelphia Automobile Trade Association.
- Jan. 15-20.....New York City, Madison Square Garden, Twelfth Annual Show, Commercial Division, Automobile Board of Trade.
- Jan. 15-20.....Toledo, O., Annual Show, Terminal Building, Toledo Automobile Dealers' Association.
- Jan. 22-27.....Rochester, N. Y., Annual Show, State Armory, Rochester Automobile Dealers' Association.
- Jan. 22-27.....Detroit, Mich., Wayne Gardens, Eleventh Annual Show, Detroit Automobile Dealers' Association.
- Jan. 22-27.....Providence, R. I., Providence State Armory, Rhode Island Licensed Automobile Dealers' Association, Automobile and Accessories Show.
- Jan. 22-27.....Dubuque, Iowa, Annual Show Dubuque Automobile Dealers' Association.
- Jan. 27-Feb. 10....Chicago Coliseum, Eleventh Annual Automobile Show under the auspices of the National Association of Automobile Manufacturers. Pleasure cars, first week. Commercial vehicles, second week.
- Jan. 27-Feb. 10....Pittsburgh, Pa., Sixth Annual Show, Automobile Dealers' Association of Pittsburgh, Inc. Pleasure cars, first week. Commercial vehicles, second week.
- Jan. 29-Feb. 3.....Scranton, Pa., 13th Regiment Armory, Second Annual Show.
- Feb. 1-7.....Washington, D. C., Annual Show, Convention Hall.
- Feb. 3-10.....Montreal, Canada, National Show, Drill Hall, Automobile Club of Canada.
- Feb. 3-10.....Harrisburg, Pa., Third Annual Show, Arena.
- Feb. 5-10.....Buffalo, N. Y., Convention Hall, George C. Fehrman.
- Feb. 5-17.....St. Louis, Mo., Coliseum, Annual Show, Pleasure cars, first week. Commercial vehicles, second week.
- Feb. 10-17.....Atlanta, Ga., Auditorium-Armory, Atlanta Automobile and Accessory Dealers' Association.
- Feb. 12-17.....Ottawa, Ont., Howick Hall, Annual Show, Ottawa Valley Motor Car Association.
- Feb. 12-17.....Kansas City, Mo., Annual Show, Combined Association of Motor Car Dealers.
- Feb. 12-17.....Troy, N. Y., Second Annual Show, State Armory, Troy Automobile Dealers.

- Feb. 12-19.....Dayton, O., Third Annual Show, Dayton Automobile Club.
- Feb. 14-17.....Grand Rapids, Mich., Third Annual Show.
- Feb. 17-24.....Pittsburgh, Pa., Second Annual Show, Exposition bldg., Pittsburgh Auto Show Association, Inc.
- Feb. 17-24.....Newark, N. J., Fifth Annual Automobile Show, New Jersey Automobile Exhibition Company, First Regiment Armory.
- Feb. 17-24.....Minneapolis, Minn., National Guard Armory and Coliseum, Annual Automobile Show, Minneapolis Automobile Show Association.
- Feb. 19-24.....Omaha, Neb., Seventh Annual Show, Auditorium, Omaha Automobile Show Association.
- Feb. 19-24.....Hartford, Conn., Annual Show, Automobile Club of Hartford, State Armory.
- Feb. 19-24.....Cincinnati, O., Annual Show, Music Hall, Cincinnati Automobile Dealers' Association.
- Feb. 20-24.....Binghamton, N. Y., State Armory, Third Annual Show, Automobile Dealers' Association.
- Feb. 20-28.....Baltimore, Md., Annual Show, Baltimore Automobile Dealers' Association.
- Feb. 21-24.....Louisville, Ky., Fifth Annual Show, First Regiment Armory, Louisville Automobile Dealers' Association.
- Feb. 21-28.....Toronto, Ont., Annual Show, The Armouries, Toronto Automobile Trade Association.
- Feb. 24-March 2...Brooklyn, N. Y., Twenty-third Regiment Armory, Annual Show, Brooklyn Motor Vehicle Dealers' Association.
- Feb. 26-Mar. 2.....Elmira, N. Y., Second Annual Show, Elmira Automobile Club.
- Feb. 26-Mar. 2.....Paterson, N. J., Annual Show, Fifth Regt. Armory, Paterson Automobile Trade Association.
- Feb. 26-Mar. 3....Quincy, Ill., Highland Park Stone Pavilion, Annual Mississippi Valley Show, Quincy Auto Club.
- Feb. 28-Mar. 2.....Davenport, Iowa, Annual Show, Davenport Automobile Association.
- March 2-9.....Boston, Mass., Tenth Annual Show, Boston Automobile Dealers' Association, Inc.
- March 4-9.....Deuver, Col., Auditorium, Annual Show.
- March 4-9.....Deuver, Col., Annual Show, Auditorium, Motor Field.
- March 6-9.....Tiffin, O., Second Annual Show, *The Advertiser*.
- March 12-16.....Syracuse, N. Y., Fourth Annual Show, State Armory, Syracuse Automobile Dealers' Association.

Meetings, Etc.

- Jan. 8.....New York City, Waldorf-Astoria, Annual Meeting of the Motor and Accessory Manufacturers, Inc.
- Jan. 18-19.....New York City, Madison Square Garden, Annual Meeting Society Automobile Engineers.

Race Meets, Hill-Climbs, Etc.

- Dec. 25-26.....Los Angeles, Cal., Track Races, Motordome.



Vol. XXV Thursday, December 28, 1911 No. 26

**THE CLASS JOURNAL COMPANY**

H. M. SWETLAND, President

CONDE NAST, Vice-President and General Manager

E. M. COREY, Secretary and Treasurer

231-241 West 39th Street, New York City

WESTERN OFFICE—910 South Michigan Ave., Chicago, Ill.

BRANCHES—Boston, 1085 Old South Building; Cleveland, 309 Park Building; Detroit, 627 Ford Building

Cable Address - - - - - Autoland, New York  
Long Distance Telephone - - - - - 2046 Bryant, New York

**SUBSCRIPTION RATES**

United States and Mexico - - - - - One Year, \$3.00  
Other Countries in Postal Union, including Canada - - - - - One Year, 5.00  
To Subscribers—Do not send money by ordinary mail. Remit by Draft, Post-Office or Express Money Order, or Register your letter.

Entered at New York, N. Y., as second-class matter.  
The Automobile is a consolidation of The Automobile (monthly) and the Motor Review (weekly), May, 1902, Dealer and Repairman (monthly), October, 1903, and the Automobile Magazine (monthly), July, 1907.

**The Get-Together Spirit**

WITH the return of Christmas and New Year's the mind naturally turns to review the affairs of the year, the progress of the seasons, the forces that have been the molding influences, the factors that have been for good or ill during the previous twelve-month. The year just drawing to a close has been fraught with much of interest insofar as the automobile is concerned; it has shown more unity of purpose among the makers than has ever been evidenced before and it has been a year of real progress. There has been in evidence more of a spirit of get-together than ever before. The engineers set the ball rolling in this co-operation scheme through the excellent work of the Society of Automobile Engineers. The midsummer convention and the recent trip abroad have both proven the value of a good interchange of ideas; both have taught the members that strength is in unity and not in isolation. The days when the engineer wanted to play the rôle of the Pharisee are over. This society has been the means of bringing to light some of the profoundest secrets of the industry. Only a year or so ago many engineers refused to even discuss many of their ideas with their intimate friends. They seemed to imagine that they possessed the only solution of the motor, the ignition, the carbureter or the self-starting problem and that if they opened their mouths the magic would depart from them. This old rule is passing away. The new wine is too strong for the old bottles and the rising engineers are men not afraid to meet face to face with others and give their opinions of present tendencies and trends.

What the engineers are doing the sales managers could do to great advantage. If there is any department of the industry in which new ideas and new blood are needed it is in the sales departments. The fossils have one by one been dropping off for the last 18 months, but the trouble is to get new blood to take their places. New salesmen are needed in every city—salesmen who have

address, who have knowledge, who are students of psychology and who have ability. It would be a good investment if all of the factories would appoint their sales managers delegates to a convention in which the fine art of salesmanship would be discussed from every angle. Education of the masses is the big need. There are a few who know, but for each one who knows there is a score who do not know. Conventions of this nature would be a great investment to the industry—an investment that would pay twenty, thirty or fifty-fold. Some say that such a convention would be impossible; that the head salesmen could not be brought together; that if they should convene those who know would refuse to give away their knowledge to those who do not know, and that the entire scheme would be a failure. Many talked in this strain before the Society of Automobile Engineers attained its present standing. The facts have proven otherwise, and although many of the engineers refused to discuss matters at the start and although many still refuse to enter into such discussions, still there has been much good come of the discussions that have taken place, due to the general freedom of speech and expression that has been developed since the society began its work. What has happened with the engineers would happen with the salesmen. That is the one big reason why such a convention should be encouraged.

Among others prominent in the industry who should get together are the automobile dealers in the big cities and towns in the different parts of the country. The dealers are the least prosperous class connected with the industry. Many of them are poor because they worked to make themselves so. They should not be disappointed when the harvest reaped is the natural result of their actions. Many, yea, scores and even hundreds, have bitten on the second-hand car proposition. Not a few have tied up all of their profits in the used cars they have taken in part payment for new ones, and at the close of the season they find themselves unable to make the necessary deposits on 1912 cars. Scores of the dealers imagined that they had to keep cars moving off the sales-room floor. One was frank enough to say that his actual profit on the sale of a new car was \$2.70. This is not much of a margin on which to pay rent, pay sales, office and garage employees, pay insurance and a hundred other expenses in conjunction with a salesroom, and live and lay aside something for the future.

The dealers should make money. They are the people who are closest to the buying public. They are the thermometer by which the public gauges the standing of the industry. If the dealers are poor, the business men will naturally estimate the industry accordingly. Dealers should get together and better their lot. If the factory is not giving them a fair show, then the best way to get justice is to get together and demand those rights which are rational and just. The dealers will get more if they band together than if they act single-handed. Only a few weeks ago a great many of the Secretaries of States from scores of states throughout the country met to study the best laws for the control of automobiles. They talked the pros and cons were well discussed. The man from New York learned from the man from Illinois, and the Oklahoma delegate got many points of information from the Connecticut delegate. All went home filled with ideas. The man who gave to others his good ideas was perhaps happier than he who went home

loaded to the guards with facts. What can be done for legislation can be done for the dealers. A big dealers' convention should be called in Chicago. It is the most central point. A national organization, for the purpose of controlling such conventions, should be planned. A good sensible program should be arranged, and each dealer attending would find himself amply repaid for the time and money expended.

"Know your business better" is the slogan of the motor car business. One dealer acknowledged a week ago that he never knew exactly what departments of his business were making money and what departments were being

operated at a loss. He put on an accountant. He was amazed at the results. Departments that he imagined to be self-sustaining were draining the more fruitful ones. Once he knew where he stood it was possible to make investigation into the causes of the loss and prescribe remedies.

Every dealer should look to this department of his work. He should systematize more. With increasing competition more efficient management of branches and salesrooms is imperative. It will require more brains to make money as a dealer during the coming year than it did last year. Real effort is needed.

## S. A. E. Shows Remarkable Growth

THE Society of Automobile Engineers will close the year with nearly 1,200 members. Applications for membership are coming in at the rate of 100 a month.

The annual meeting of the society will be held in New York, January 18-20. This is during the week of the commercial vehicle division of the automobile show at Madison Square Garden. The sessions of the society will take place in the assembly hall of Madison Square Garden. The program follows:

Disintegration of Fuel Particles and Homogeneous Carbureting of Air, by Forrest A. Heath.

Standardization of Drawings, by George W. Dunham.

Compound Gas Engines and Their Efficiency, by Eugene P. Batzell.

Present Status of Automobile Lighting, Gas and Electric, by J. W. Esterline and A. E. Berden.

Position of Brakes; Double-rear-wheel versus Propeller-shaft; Front-wheel Brakes, by S. I. Fekete.

Definitions in Connection with Physical Properties of Steel, by Henry Hess.

Mechanical Points in Connection with the Construction of Solid Motor Tires, by Charles B. Whittelsey.

Silent Chains, by Chester S. Ricker.

Automatic Spark Advance, by Lon R. Smith.

Underslung Frames, by S. I. Fekete.

Balance of Motors, by Ernest R. Fried.

Self Starters for Gasoline Motors, by J. W. Fitzgerald.

Multiple Disc Clutches, by Joseph A. Anglada.

The following divisions of the now famous Standards Committee will have reports to present:

Ball and Roller Bearings, David Fergusson, chairman.

Broaches Division, C. E. Davis, chairman.

Carbureter's Division, G. G. Behn, chairman.

Frame Sections Division, J. G. Perrin, chairman.

Iron and Steel Division, Henry Souther, chairman.

Miscellaneous Division, A. L. Riker, chairman.

Subjects in connection with report of miscellaneous division:

Standard Gauge Tread for Pleasure and Commercial Vehicles, Electric Lighting Outfits, Magneto Dimensions, Spark Plug Thread Tolerance, Vehicle Taxation Formula, Metal Gauges, Oversize Standards for Pistons, Bushed Yoke and Eye Rod Ends, Limits for S. A. E. Screw Threads.

Nomenclature Division, H. E. Coffin, chairman.

Seamless Steel Tubes Division, H. W. Alden, chairman.

Springs Division, A. C. Bergmann, chairman.

Truck Standards, W. P. Kennedy, chairman.

Advantages and Disadvantages of Large Driving Wheels; Increasing the Utility of Commercial Cars by Auxiliary Loading and Unloading Devices, by E. W. Curtis, Jr.

General Problem of City Freight Transportation.

Several hundred members are expected from all over the United States. Henry Souther, president of the society, will

preside over the deliberations. The annual election of officers will be held during the session. A feature of the meeting will be an account of the first European visit of the society. The subject will be introduced generally by Henry F. Donaldson. Then several points of live technical interest will be taken up. Wire wheels for motor cars will be discussed and the results of some new comparative tests of crushing and dishing strength of hickory and wire wheels will be submitted. C. B. Hayes and Bert Morley will take part in the discussion of this subject. The subject of silent chains for accessory motor drives and for gear boxes will be taken up. The worm gear drive will be discussed by David Fergusson, E. R. Whitney, C. E. Davis and W. C. Baker. Sleeve-valve motors will also be treated at considerable length, H. E. Coffin, Henry Souther and J. B. Hull entering into the discussion. Minor points and peculiarities of European motor-car design and construction will be pointed out and analyzed. A group of the American automobile engineers visiting Europe was the commercial vehicle division.

### Death of Georges Dupuy

The death of Georges Dupuy is announced in *L'Auto* of December 13. Dupuy was widely known to members of the American automobile industry, having worked for several years as a writer for various automobile journals in this country, while later he returned again to inspect and describe American factories for *La Vie Automobile*, *L'Auto* and other French journals. He was the master of a very vivacious style, especially in French, and embraced all sports as well as philosophical economics in his repertoire. He was sent by *Le Figaro* to Reno to report the Jeffries-Johnson fight, and his description of this encounter was considered an exceptional piece of work.

### H. W. Whipple Suddenly Stricken

BOSTON, Dec. 26—Harlan W. Whipple, one of the early presidents of the American Automobile Association, died suddenly last night of heart trouble while visiting at the home of Col. Smith M. Decker, at Lawrence. The latter's home is near that of Mr. Whipple. Mr. Whipple was just preparing to go home when he was stricken.

In the early days of motoring Mr. Whipple became a devotee of the sport. He gained prominence and was elected President of the American Automobile Association in 1904. That same year he led the contestants in the famous run to the St. Louis exposition, driving car No. 1. In 1905 he was re-elected President of the A. A. A.

He was born at South Dartmouth, Mass., Oct. 8, 1865, graduated from Phillips, Andover and Williams College, then entered business first in Chicago, next in San Francisco and finally at New York.



# Planning Ocean-to-Ocean Highway

PHOENIX, ARIZ., Dec. 26—Eighty-four delegates from Arizona, California and New Mexico met in the State Capitol at Phoenix, December 20 and 21, and formed the Ocean-to-Ocean Highway Association. The main object of the association is to work for the construction of a transcontinental automobile highway passing through the three states represented.

It was left to the three delegates to decide upon the route to be taken by the highway in each state. Arizona and New Mexico had no trouble in reaching an agreement, but eleven California delegates withdrew from the organization when the convention refused to receive their minority report.

Governor Richard E. Sloan of Arizona issued the call under which the convention was held. He called the delegates to order at 10 o'clock Wednesday morning and the business in hand was transacted with astonishing rapidity. The following officers were elected: President, John S. Mitchell, Los Angeles; secretary, J. S. Conwell, Los Angeles; treasurer, A. W. Ballard, Phoenix; vice president for California, A. G. Spalding, San Diego; vice president for Arizona, Del M. Potter, Clifton; vice president for New Mexico, D. B. Sellers, Albuquerque. The legislative committee chosen consists of Stoddard Jess, Los Angeles; Thomas Early, Pasadena; F. A. Miller, Riverside; A. W. Balfour, Pomona; Rufus Choate, San Diego. All the members of this committee are Californians.

One of the first acts of the convention, after President Mitchell took the chair, was to unanimously select Santa Fe, New Mexico, as the place for the second annual convention, to be held the third week in October, 1912.

When the convention adjourned in the afternoon it was with the understanding that the three delegations should caucus and endeavor to agree upon the route through each state which they wished the national highway to take. It had already become apparent, however, that the California delegation was hopelessly split. The eight delegates from San Diego and three from the southern part of the Imperial Valley were in the minority. Knowing themselves outnumbered, they refused to caucus with the majority.

Next morning the California majority, the New Mexico and Arizona delegations presented their reports, which were approved by the convention as read.

The New Mexico route recommended in the report starts at the Arizona line sixteen miles east of Springerville and proceeds eastward to Magdalena, Socorro, San Antonio, Carthage and Albuquerque; thence to Santa Fe, Las Vegas and Raton, leaving the state on the old Santa Fe trail twelve miles north of Raton on the Colorado state line.

Following is the Arizona report: "Resolved, That the transcontinental highway, in crossing the state of Arizona, shall begin at Yuma on the Colorado River and run thence along the course of the state highway as heretofore surveyed to the city of Phoenix, thence by way of Tempe and Mesa to the Roosevelt dam, thence to the city of Globe over the state highway already constructed, thence to San Carlos on the Gila River, thence up the Gila Valley to Clifton, thence northerly to Springerville, thence easterly to the Arizona and New Mexico line to form a junction with the highway as constructed through the state of New Mexico."

The California majority report follows: "Whereas, the California delegation of the Ocean-to-Ocean Highway Association, in caucus assembled, believing that the route presenting the fewest geographical and physical obstacles should be endorsed for the national highway, having under consideration the advantages of having such a highway pass through as much set-

ted territory as possible, and within striking distance at all times of a transcontinental railroad, therefore be it

"Resolved, That the California delegation recommend as a course for the national highway a route running westerly from Yuma, along and near the Southern Pacific railway to a point about 4 1-2 miles west of Mammoth station, thence southwesterly to Brawley, thence northwesterly along the south and west side of Salton Sea to Mecca, thence along the main line of the Southern Pacific railroad to Beaumont, Redlands Junction, Colton, thence by shortest road to Los Angeles."

San Diego endeavored to present a minority report recommending that the route in California start at Yuma and proceed through the southern part of the Imperial Valley, El Centro and Holtville, on to San Diego. As the San Diegoans had refused to caucus, the minority report was not received. Thereupon the San Diegans announced that they would withdraw from the organization. A. G. Spalding, vice president for California, and Rufus Choate, member of the legislative committee, would not serve, they said.

It is not the intention of the association to immediately ask for federal aid in building the transcontinental road through Arizona, New Mexico and California.

Rough drafts of articles of association and by-laws for the organization were drawn by a committee appointed for that purpose and approved by the convention. To Mr. Norris was entrusted the work of whipping them into legal form. The rough draft sets forth the object of the Association as follows:

"First: That establishment of a system of national highways which shall traverse the states of California, Arizona and New Mexico and such other states as may choose to affiliate themselves with and become a part of this organization.

"Second: For the establishment of a uniform system of road building, which system of road building shall be uniform and meet at given and common points to be established by the states of California, Arizona and New Mexico, said points to be established by the several states.

"Third: To obtain federal aid and co-operation toward the establishment of a system of interstate roads between the states of California, Arizona and New Mexico and such other states as may affiliate themselves with this organization.

"Fourth: To obtain the co-operation of all states in the Union for the purpose of obtaining federal aid toward the establishment of a series of national highways traversing the United States of America and to that end we earnestly request the co-operation of all states in the Union and assure them of our hearty co-operation in bringing about said highway to promote the objects of this organization."

On Wednesday evening the delegates to the convention were entertained at a banquet by the City Club of Phoenix.

## Pennsylvania Surveys Roads

YORK, Dec. 26.—Engineers of the Pennsylvania state highways department have completed the surveying of sixty-five of the routes for main highways carried by the Sproul main highway act of 1911, according to a report just made to Highway Commissioner E. M. Bigelow, by Samuel D. Foster, chief engineer of the department. Included in these sixty-five routes are 2,755 miles, all of which have been surveyed, and of this length 621 miles has been plotted.

All these dirt roads will be taken by the state June 1 next and maintained by the state highway department. The toll roads will not be surveyed until they have been taken over by the

state, as they will have to be purchased from the various companies owning them.

The routes surveyed include the following: Sunbury to Danville, Bloomsburg to Wilkes-Barre, Scranton to Montrose, Bloomsburg to Laporte, Sunbury to Williamsport, Wellsboro to New York state line, Lewisburg to Sunbury, Harrisburg to Carlisle, Carlisle to Chambersburg, Chambersburg to Maryland line, Gettysburg to Maryland line, Bedford to Hollidaysburg, Ebensburg to Hollidaysburg, Huntingdon to Hollidaysburg, Clarion to Franklin.

Pittsburgh to Butler, Butler to Mercer, Mercer to Ohio line, Mercer to Meadville, Meadville to Franklin, Meadville to Erie, Erie to Warren, Warren to Smethport, Smethport to New York line, Ridgway to Emporium, Coudersport to Wellsboro, Washington to Waynesburg, Waynesburg to West Virginia line (2), Uniontown to Washington, Washington to West Virginia line, Washington to Beaver.

Gettysburg to York, Philadelphia to Media, Philadelphia to Maryland state line, West Chester to Delaware state line, York to Harrisburg, Philadelphia to Doylestown, Doylestown to Easton, Philadelphia to Delaware line, West Chester to Maryland line, Harrisburg to Lancaster, Lancaster to Maryland line, Harrisburg to Gettysburg, Wellsboro to Towanda, Hollidaysburg to Clearfield, Bedford to Ebensburg, Tunkhannock to New York line, Washington to Greensburg, Coudersport to New York line, Pittsburgh to New Castle, Franklin to Mercer, Warren to Mercer, New Castle to Meadville, Reading to Allentown, Allentown to Easton and Allentown to Mauch Chunk.

### Maryland Chief Asks Change in Law

BALTIMORE, MD., Dec. 26—Governor Austin L. Crothers, the retiring chief executive of Maryland, in his message to the

Legislature, recommends that the office of Motor Vehicle Commissioner be abolished by the state and that the enforcement of the law be placed in the hands of the state roads commission. In discussing the motor vehicle law and the changes he suggests, Governor Crothers said:

"This law, passed by the last legislature for securing state revenue from the use of motor cars and to regulate and make safer their travel upon the public roads, has been a success. The revenue collected by this department in licenses issued has amounted to \$103,000. I believe in 5 years this will reach \$300,000, which will go to the maintenance and building of state roads.

"The motor car is here to stay. Could we not manufacture them to a greater extent within our own state and keep the money at home?"

### Wisconsin to Build 645 Miles of Road

MADISON, WIS., Dec. 26—The Wisconsin Highway Commission, created by an act of the last legislature appropriating \$350,000 annually for an indefinite period of years for state aid for highway construction, has just announced that \$1,250,000 will be expended in this state during 1912 for highway improvement as the result of the granting of state aid.

This total has surprised even the most enthusiastic supporters of state aid and proves that the state aid law is being received in a most gratifying manner. The details of the expenditures reported by the commission are as follows: Stone roads, 220 miles; gravel roads, 150 miles; shale road, 25 miles; dirt road, 250 miles, a total of 645 miles. In addition there will be constructed under this act 140 bridges to cost \$150,000 and divided among 123 townships. Never before in the history of Wisconsin has there been so great a proposed expenditure for highway work.

## Entries for the French Grand Prix

UNDER date of December 9 there had been entered for the Grand Prix and Coupe de l'Auto races—to take place jointly in June, 1912, if 30 entries are booked before December 30, 6 o'clock evening—the following cars: 4 Lorraine Dietrich, 4 Gregoire, 4 Lion-Peugeot, 2 Peugeot and 4 Darracq. The following were mentioned as sure to be booked immediately the nominations having been forwarded: 4 Sizaire-Naudin, 3 Alcyon and of English cars 3 Calthorpe and 3 Sunbeam. "This is without counting those which we shall soon name," adds Charles Faroux, the editor of *La Vie Automobile* and original organizer of the Coupe de l'Auto, writing in *L'Auto*, the daily automobile and sporting journal of Paris. This journal is also in receipt of a communication from the Mathis firm of Alsace-Lorraine announcing that this manufacturer has refused to join the German boycott of the two races, and in another paragraph it is intimated that the real reason for the unfriendly action of the other German firms is to be sought in the fact that one of the foremost among them recently lost its chief engineer, who emigrated to a neighboring country, taking with him all his assistant designers, and the firm, finding itself unable to compete with much hope of winning, engineered a general German boycott to save its own prestige.

### Quakers Ask for Fairmount Date

PHILADELPHIA, Dec. 26—Notwithstanding the fact that Dr. J. William White, a member of the Fairmount Park Commission, has taken preliminary steps to halt the running of the Fairmount Park road race, and that the holding of the 1911 event created a deficit in the organization's treasury, application for sanction has been made and a date has been assigned to the Quaker City

Motor Club by the American Automobile Association for the 1912 race for Saturday, October 5.

In addition to the admission of about 30 new members at a meeting held this week in the clubrooms, Hotel Walton, plans were made for an active winter, a feature of which will be a series of lectures on automobile topics—engines, tires, radiators, etc. The first of these talks will be given in the middle of January, when Charles Y. Knight, the inventor of the engine bearing his name, will deliver a lecture on engines.

### Race Promoters Ask for Big Dates

Applications for racing dates covering six of the great automobile road racing and speedway features for 1912 have been filed with the Contest Board of the A. A. A. The Elgin national stock car races will be held August 30-31, according to the request on file. This will almost certainly be granted by the board.

The Quaker City Motor Club has also applied for the date of October 5 for holding the annual Fairmount Park road race and it is understood that there will be no trouble in securing that date for the event. At Bakersfield, Cal., a road race will be held, probably February 22, and such reservation is expected to be made this week upon receipt of formal application.

The Indianapolis Speedway has applied as usual for race dates on Memorial, Independence and Labor days. The latter date, the first Monday in September, comes pretty close to the tentative dates for the Elgin stock car meeting and some sort of an adjustment is expected to do away with the difficulty.

Los Angeles automobilists have inquired of the A. A. A. whether a sanction will be required for the race meet now planned as a benefit for Hanshue, injured during the desert race.



Fleet of Commer trucks now in use by H. L. Herbert & Company, coal dealers, of New York City

**NEW YORK CITY**—The firm of H. L. Herbert & Company is one of the numerous coal-dealing concerns which are changing from the old system of delivery with horses to the motor truck system. The company has a fleet of eight Commer trucks in service and is finding the new way much cheaper and more efficient than the old.

**DENVER, COL.**—J. C. Fry, J. W. Ebert and R. M. Robertson have joined the sales-force of the local branch of the Metzger Motor Car Company.

**SYRACUSE, N. Y.**—The Hupmobile agency here has been taken over by Frank P. Anderson, who handles the Alco in this territory. C. H. Marshall was formerly the Hupmobile agent.

**ATLANTA, GA.**—The Atlanta Automobile and Accessory Dealers' Association will hold an automobile show in the Auditorium-Armory from February 10 to 17. Homer C. George is manager.

**FLINT, MICH.**—F. W. A. Vesper has resigned his position as manager of the Texas Buick Company of Dallas, Tex., to become assistant general sales manager of the Buick Motor Company of this city.

**DENVER, COL.**—The R. C. Hupp Company has appointed the following agents in this territory: Browning Bros., Ogden, Utah; R. C. Tarrant, Sheridan, Wyo.; P. W. Pitman, Las Animas, Col., and Ideal Motor Company, Pueblo, Col.

**SYRACUSE, N. Y.**—A new automobile company is shortly to be incorporated in this city to be known as the E. B. Sabine Company. The Bissell garage will be the

temporary home of the company, which will handle the Cutting car.

**CHICAGO, ILL.**—The American Electric Company, State street, Chicago, has opened a permanent downtown sales and show room at 1254 Michigan Boulevard in the New Southern Hotel building. This has been designated the Samson Horn Store.

**NEW YORK CITY.**—The Philadelphia Storage Battery Company has opened a new New York office in the American building, Broadway and Columbus Circle, in order to facilitate the handling of its increasing business in electric vehicle batteries and other types of batteries used in the automobile trade.

**ATLANTA, GA.**—A state association of automobilists will be formed at a meeting which will be held in Atlanta, January 2. G. W. Hanson, chairman of the meeting and the originator of the scheme, appointed Walter P. Andrews as chairman of a committee to draw up a constitution and by-laws. The clubs of Savannah, Macon, Augusta, Griffin, Americus, Albany and Rome will affiliate with the state body.

**DENVER, COL.**—The Overland Auto Company, Western distributor for the Willys-Overland Company, has appointed the following agents in their territory: Canyon City Auto Company, Canyon City, Col.; Paul Auto Company, Colorado Springs, Col.; Tyler Auto Company, Pueblo, Col.; R. K. Young, Salida, Col.; W. Whalen, East Las Vegas, N. Mex.; Monte Vista Motor Car Company, Monte Vista, Col.; F. W. Roedel, Cheyenne, Wyo.; J. H. Walker & Son, Santa Fé, N. Mex., and Forest Lumber Company, Fort Collins, Col.

**DETROIT, MICH.**—The new Miller carbureter, which is now manufactured in Los Angeles, Cal., will now be manufactured in the east as soon as the factory is completed in this city. The company has secured E. J. Edmond, of 1783 Broadway, New York City, to handle the carbureter in the Eastern states.

**ANDERSON, IND.**—William O. Kennington, of London, England, has accepted the position of assistant chief engineer with the Remy Electric Company of this city. Mr. Kennington, while a young man, has had a long experience in the electrical engineering profession.

**EVANSVILLE, IND.**—The Columbia Taxicab Company has been organized here to conduct a taxicab and baggage delivery service. The company has been incorporated with an authorized capitalization of \$10,000, the principal stockholders and directors being E. C. Kinkle, Walter Wheeler, A. C. Mathias and H. E. Hulsmann.

**FINDLAY, O.**—The Main Garage, on North Main street, has been sold by its owner, Earl Myers, to George Koogle. The business was established several years ago.

**DES MOINES, IA.**—Twenty-five Overland agents from Central met in Des Moines Monday as the guests of the Riddell Auto Company, local agent for the company. T. C. Whitcomb, sales manager, was present.

**Owosso, MICH.**—A deal has been closed by which E. A. Eddy, Sr., and his son, both of Bay City, become owners of the equipment of the defunct Owosso Motor Company. They expect to manufacture the car in Bay City. The Owosso company was made up of local business men.

DENVER, COL.—The Boss Rubber Company has added the Kelly-Springfield tire to its line.

COLUMBUS, O.—The contract has been awarded for a large garage at Sixth and Kaiser streets for the George W. Bobb Company.

KANSAS CITY, MO.—The Truffault-Hartford Company has opened a branch in this city at 1524 Grand avenue. Henry Romer is in charge.

CLEVELAND, O.—The Brooks - Norton Motor Sales Company, of 1927 Euclid avenue, has taken the agency for the Ohio electric and the Modern truck.

SPRINGFIELD, O.—The Springfield Tire & Rubber Company has increased its capital from \$50,000 to \$150,000 and will make additions to its factory next year.

ATLANTA, GA.—The Premier Motor Manufacturing Company will open a southern service department in Atlanta about January 15. J. E. Levi will be in charge.

PHILADELPHIA.—W. R. Darrah, E. G. Brown and Robert Yerger have recently become affiliated with the Paxton-Crumley Auto Company, of 660 North Broad street.

COLUMBUS, O.—E. H. Wilson and J. C. Langley, proprietors of the Enterprise Garage at 241 West Fourth avenue, have taken the central Ohio agency for the Star starter.

LOUISVILLE, KY.—The Automobile Club of Louisville has got out a club paper entitled *Toots*. E. J. Strauss is managing editor and Colonel W. B. Haldeman is editor.

MANCHESTER, N. H.—The C. R. Sawyer Company, of this city, has closed with the Velie Boston branch for the sale of Velie pleasure cars and trucks in this section of New Hampshire.

PHILADELPHIA—H. A. Jenks has joined the sales force of the Philadelphia Loco-

mobile Company. Mr. Jenks was formerly connected with the Philadelphia branch of the Stoddard-Dayton.

ATLANTA, GA.—Henry Nyberg, of the Nyberg Automobile works, of Anderson, Ind., and Chicago, recently visited Atlanta and it is reported that he plans to open an automobile factory here.

UTICA, N. Y.—The Millers Motor Company, 109 Arcade building, with garage at 7 Jewett place, has taken the agency for the Metz automobile made by Charles Metz, a former Utican.

DETROIT, MICH.—C. A. Hamilton, who has been vice-president and general manager of the Wisconsin Engine Company, has resigned his position to take an interest in the Lavigne Gear Company.

COLUMBUS, O.—The Adamson Automobile Company, of 5 West Mound street, has taken the distributing agency for the Paige-Detroit for Franklin, Delaware, Madison, Pickaway and Union counties.

PROVIDENCE, R. I.—W. P. Kennedy has been appointed head of the transportation cost bureau which has been established by the American Locomotive Company in connection with the motor truck department.

CUMBERLAND, MD.—The partnership of Blays & Cochrane, trading as the Queen City Garage, has been changed to the Queen City Garage, Inc., B. H. Blays having disposed of his interest to the latter corporation, of which Alpheos B. Cochrane is the president.

ANDERSON, IND.—Mr. J. L. Elwood has affiliated with the service department of the Remy Electric Company, with headquarters at the factory in this city. Mr. Elwood was lately engineer of the Sam'l L. Moore Sons' Company, of New York City and Elizabeth, N. J.

KANSAS CITY, MO.—The Missouri Valley Auto Company has been placed in the hands of a receiver. The company handled the

White car and was one of the oldest firms in the city. The White Motors Company, a newly organized concern, will handle the White at 1616 Grand avenue.

BOSTON, MASS.—The J. W. Bowman Co., distributors of the Stevens-Duryea cars, is to have one of the largest and most completely equipped service stations possessed by any automobile dealer in New England. It is being erected on Vassar street, Cambridge, and is a one-story structure with 30,000 square feet of available floor space.

DENVER, COL.—The Western Marion Motor Company, which handles the Abbott-Detroit and the Marion for this territory, will begin the new year under the name of the Western Motor Car Company. This firm was also recently made the agent for the American self-starting device.

NEWCASTLE, IND.—W. F. Byrket, who has been connected with the United Motor Company in various capacities for several years, has been appointed manager of the United Motor Indianapolis Company. He succeeds Thomas L. Marshall, who will become assistant superintendent of the company's central sales district.

CLEVELAND, O.—A reorganization of the Motor Tire & Repair Company at 6506 Euclid avenue has been effected. E. C. Anderson continues as the active head of the company. Those associated with him are: H. L. Lance, C. B. Haycox and C. A. Stimson. The company will continue to handle the Republic car.

SEATTLE, WASH.—J. T. Geena & Company, Packard agents are erecting a new building on the southeast corner of Pine street and Twelfth avenue. When completed the Packard building will be one of the most complete, modern automobile salesroom and garage buildings on the Pacific Coast. It will have about 40,000 square feet of floor space.



First annual convention of the Speedwell truck agents, at the factory in Dayton, Ohio



Showing the average weekly output of Knox trucks for 1911

WAPAKONETA, O.—The Hauss & Bitler Company has taken the 1912 agency for the Stoddard-Dayton in this territory.

LOS ANGELES, CAL.—Curtiss-Shea-Cox, Inc., are planning to erect a plant in this city for the manufacture of automobiles.

COLUMBUS, O.—Messrs. Sperry and Hoover have taken over the repair business of the Adamson Automobile Company at 35 West Mound street.

BOSTON, MASS.—The Henley-Kimball Company, agent for the Hudson, is having a service station constructed in Cambridge.

SCRANTON, PA.—Application for a patent for a flexible steel tire for automobiles has been made to the government by John Dougherty, of 1003 Prospect avenue.

PONTIAC, MICH.—Pontiac Power Company, which recently acquired the Rapid Motor Vehicle Company's power plant, has been authorized to expend \$36,000 in improvements.

SPRINGFIELD, ORE.—A company has been organized here by D. Tower for the manufacture of automobile trucks. Local capital has been subscribed and a small factory has been started.

KANSAS CITY, MO.—The Hartford Suspension Company, manufacturer of the Traffault-Hartford shock absorber, has opened a branch factory at 1542 Grand avenue. Harry Roemer is manager.

BOSTON, MASS.—Roscoe B. Davis, for several years with the Maxwell branch in Boston and later with other agencies, has joined the sales force of the Empire Motor Car Company, agent for the Empire and Stutz cars.

NEW HAVEN, CONN.—Knight's Garage, Inc., of this city, has closed with Harold D. Bornstein of the Velie Boston branch for the sale of Velie pleasure and commercial cars in New Haven and New London counties.

DETROIT, MICH.—Henry Goodman, eastern traveling salesman for the Flanders Manufacturing Company, has resigned his position and accepted a position with the Grinnell Electric Car Company, of Detroit, as general sales manager.

COLUMBUS, O.—The net receipts of the Ohio State Automobile Department for the year ending December 15, 1911, were \$156,680.65. This amount goes to the fund for the building and maintenance of good roads in the Buckeye State.

KENTON, O.—William Willeke of this city is the inventor of a device to regulate gas tanks on automobiles, which is claimed to be the best of its kind ever conceived. An automobile manufacturing concern is negotiating for the purchase of the device.

DETROIT, MICH.—J. H. Newmark, for four years advertising manager of the Oakland Motor Car Company, of Pontiac,

Mich., has resigned that position, having been advanced by the General Motors Company to the advertising department of the parent organization in this city.

DENVER, COL.—The handsome two-story building erected by Tom Botterill at the corner of Thirteenth and Broadway is now occupied by the owner, who handles the Pierce-Arrow, the Hudson and the Columbus, and by the Colorado Automobile Company, local representative of the Cadillac.

DETROIT, MICH.—Automobile Designing Engineers' Society, an organization intended to promote the art of designing automobile motors, motor cars and tools, was formed recently at a meeting held in College of Automobile Engineering. Regular meetings will be held at the college, 287 Woodward avenue.

LIMA, O.—Two storerooms located on the east side of South Elizabeth street between Market street and Spring street, have been leased for automobile salesrooms. Henry S. Thurston will occupy one of the rooms as an agent for the Jackson line and G. W. Griffith the other as agent for the Krit.

CANTON, O.—The directors of the Stark Auto Company of this city, which was incorporated recently with a capital of \$20,000, have elected W. H. Burgener president; T. E. Huthe, general manager; Samuel Heaney, shop manager; George Shaffer, vice-president and George F. Frones, secretary and treasurer.

MILWAUKEE, WIS.—Among the new agencies in Milwaukee recently contracted for are the following: Union 25, Marx Bros.; Staver-Chicago, Henry Walter; Nyberg, Tuschan Bros.; King, Eustace Bros.; Arthur F. Tiegs, Colby; Gas Power Engineering Company, Premier and Moline; Elmore, Edwin B. Leverenz.

BOSTON, MASS.—W. H. Vinal has returned from a trip to York, Pa., where he closed a deal for the agency for Pullman cars in Eastern Massachusetts. He will at once assume the management of the Boston Motor Company, which handles the S. G. V. and the De Dion.

SPRINGFIELD, MASS.—The phenomenal growth of the truck industry in the United States is readily appreciated when one realizes that the line of trucks shown in the accompanying illustration represents only one week's output of the Knox Automobile Company of this city.

ATHENS, O.—The Ohio-West Virginia Sales Company of this city has taken the agency in southeastern Ohio for the Cutting touring cars and the Garford trucks. F. E. Shattuck is manager of the concern.

COLUMBUS, O.—The Adamson Automobile Company of 35 West Mound street, has contracted to distribute the Paige-Detroit line for 1912 in Franklin, Delaware, Madison, Pickaway and Union counties.



MILWAUKEE, WIS.—C. E. Mills has joined the Hickman-Lauson-Diener Company, state agents for the Ford.

CINCINNATI, O.—The Payne Motor Car Company, distributing the Hudson, has removed to 122-124 Seventh avenue.

PENDLETON, ORE.—A new garage and repair shop has been opened here under the title of the Oregon Motor Company.

LANCASTER, O.—The Adamson Automobile Company of Columbus, Ohio, has contracted with J. Elden Lawrence to handle the Jackson in Fairfield county.

COLUMBUS, O.—Kimmel Brothers, 215 North Fourth street, will handle the Cole line of automobiles in connection with the Speedwell.

DES MOINES, IA.—W. C. Haywood, Secretary of State for Iowa, has issued a pamphlet containing a synopsis of the new automobile laws passed by the last legislature.

BOSTON, MASS.—H. E. Leefe, formerly with the local branch of the Selden, is the latest addition to the salesforce of the Connell & McCone Company, agents here for the Overland.

MILWAUKEE, WIS.—The Milwaukee board of public works has purchased a Mitchell roadster for the use of the consolidated police and fire alarm telegraph system of the city.

NEENAH, WIS.—William C. Nash has been elected president of the Neenah Brass Works. Henry Horkman is vice-president and general manager and David Horkman is secretary and treasurer.

SPRINGFIELD, MASS.—The United Motors Company secured an option on a large tract of land in the center of the city as a site for a large building which will be utilized as a salesroom and a garage. It will cost \$150,000.

SYRACUSE, N. Y.—W. R. Shaw has purchased the entire stock held by the Strait estate in the automobile firm of Strait & Shaw and assumes sole ownership January 1. He will continue to conduct the business at No. 225 West Genesee street.

SAGINAW, MICH.—By the purchase of the stock of Charles E. Duryea, former president of the Duryea Auto Company, by C. C. Brooks, the legal difficulties in which three injunctions were issued, has been ended. Frank C. Palmerton has been elected president and general manager, which offices Mr. Duryea held.

COLUMBUS, O.—The Broadway Motor Car Company, 842 and 844 West Broad street, is the name of a firm formed by J. F. Morgan and H. F. Kaiser to handle the Paige-Detroit in Franklin county for 1912 and to do a general garage and repair business. The concern has a new building.

BOSTON, MASS.—F. R. Parker, who formerly handled the Elmore in this territory, has signed a contract with the United States Motors Company to distribute Brush cars throughout New England. He has also taken on the Staver-Chicago line for Maine, New Hampshire, Vermont and Massachusetts.

DETROIT, MICH.—The Wolverine Automobile club has made arrangements with the Michigan Central Railroad to run a special to the New York show. The train, consisting of standard sleepers, a compartment car and a buffet library car, will

leave at 3:30 o'clock Friday afternoon, arriving in New York at 9 o'clock Saturday morning. A large delegation is arranging to go from the club.

WINNIPEG, MAN.—At the annual meeting and banquet of the Winnipeg Motor Trades' Association, the following were re-elected by acclamation as officers for 1912: president, F. E. H. Lake, Russell Motor Car Company; vice-president, W. C. Power, McLaughlin Carriage Company; treasurer, G. A. Malcolmson, Ford Motor Company; secretary, A. C. Emmett, automobile editor of *Free Press*.

## Automobile Incorporations

### AUTOMOBILES AND PARTS

AUSTIN, TEX.—Regal Motor Car Co.; capital, \$1,000,000; to sell automobiles and parts.

BOSTON, MASS.—Orin Ray, Inc.; capital, \$50,000; to deal in automobiles. Incorporators: O. Ray, W. N. Tuller, H. O. Ray.

BOSTON, MASS.—Stratton Automobile Co.; capital, \$5,000; to deal in automobiles. Incorporators: H. C. Stratton, J. S. Stratton, G. W. Stratton.

BOSTON, MASS.—Rex Motor Co.; capital, \$1,000; to deal in automobiles. Incorporators: H. C. Stetson, H. W. Truc, C. F. Moore.

BROOKLYN, N. Y.—Ormond Motor Car Co.; capital, \$100,000; to deal in automobiles. Incorporators: G. H. Howell, R. McKeller, T. Downs.

BUFFALO, N. Y.—Carroll Tire Co.; capital, \$20,000; to manufacture rubber tires. Incorporators: John Gregson, George Cunliffe, J. E. Gregson.

CHICAGO, ILL.—Swanson Motor Car Co.; capital, \$50,000; to deal in automobiles, trucks, etc. Incorporators: C. E. Swanson, E. E. Challenger, M. E. Gallion.

CHICAGO, ILL.—La Salle Auto Oil Co.; capital, \$25,000; to manufacture automobile motors and accessories. Incorporators: W. R. Watson, G. W. Curtis, L. E. Powell.

CHICAGO, ILL.—Perfection Auto Tire Co.; capital, \$15,000; to manufacture automobile parts and appliances. Incorporators: R. E. Cruzen, G. R. Cruzen, D. C. Hutchins.

CHICAGO, ILL.—Mechanical Appliance Co.; capital, \$200,000; to deal in motors and generators. Incorporators: W. A. Feeney, Frank Venning.

Clio, S. C.—Hubbard Motor Car Co.; capital, \$3,000; to deal in automobiles. Incorporators: J. L. Hubbard and others.

DOVER, DEL.—Motor Owners' Tire Co.; capital, \$300,000; to manufacture and deal in automobile tires and other fixtures.

DOVER, DEL.—Samson Tire & Rubber Co.; capital, \$100,000; to manufacture rubber tires for automobiles.

HATTIESBURG, Miss.—Southern Automobile & Machine Co.; capital, \$50,000; to deal in automobiles. Incorporator: R. R. Boykin.

INDIANAPOLIS, IND.—Empire Gear Co.; capital, \$20,000; to manufacture motors, transmissions and other automobile parts. Incorporators: Frank S. Clark and Charles H. Hurd.

KANSAS CITY, KAN.—Kansas City Auburn Co.; capital, \$10,000; to deal in motor trucks. Incorporators: Charles Eckhart, F. E. Eckhart, Morris Eckhart.

MILWAUKEE, Wis.—Automatic Motor Devices Co.; capital, \$1,000; to sell automatic automobile accessories. Incorporators: H. B. Webb, C. J. Dellfield, J. T. Drought.

NEWARK, DEL.—New Garage & Electric Co.; capital, \$5,000; to manufacture and deal in automobiles. Incorporators: G. Fader, E. G. Fader, A. F. Fader.

NEW YORK CITY.—Detmar Auto Sales Co.; capital, \$20,000; to manufacture and deal in vehicles, engines and machinery. Incorporators: John McLaren, B. F. Knowlton, Edward C. Underlied.

OMAHA, NEB.—Omaha Auburn Auto Co.; capital, \$10,000; to deal in automobiles. Incorporators: Charles Eckhart, Morris Eckhart.

SALEM, N. J.—Blue Ribbon Automobile Service Co.; capital, \$25,000; to rent automobiles and deal in automobile supplies. Incorporators: G. B. Sheppard, J. D. Sharman, F. E. Hurlley.

SPRINGFIELD, Mass.—Morse-Readio Auto Co.; capital, \$150,000; to manufacture and deal in automobiles. Incorporators: G. U. Readio, G. E. Morse, E. M. White.

WILMINGTON, DEL.—American Tire & Rubber Co.; capital, \$1,500,000; to manufacture rubber tires.

### AUTOMOBILES, GARAGES, ETC.

SPRINGFIELD, MASS.—New England Auto Owners' Association; to obtain supplies at a lower price. Incorporators: R. A. McKee, A. W. Warren, M. T. Workman.

SPRINGFIELD, OHIO.—Compressed Air Machine Co.; capital, \$100,000. Incorporators: Lewis C. Kiser and others.

TOLEDO, OHIO.—Toledo Auto Delivery Service; capital, \$10,000; to conduct a transportation business. Incorporators: Chas. K. Friedman, Joseph Straus, Kittie Alexander, Joseph Alexander, Morris Tobias.



Unloading shipment of Stearns-Knight cars at San Francisco

# OF INTEREST *to the* INDUSTRY

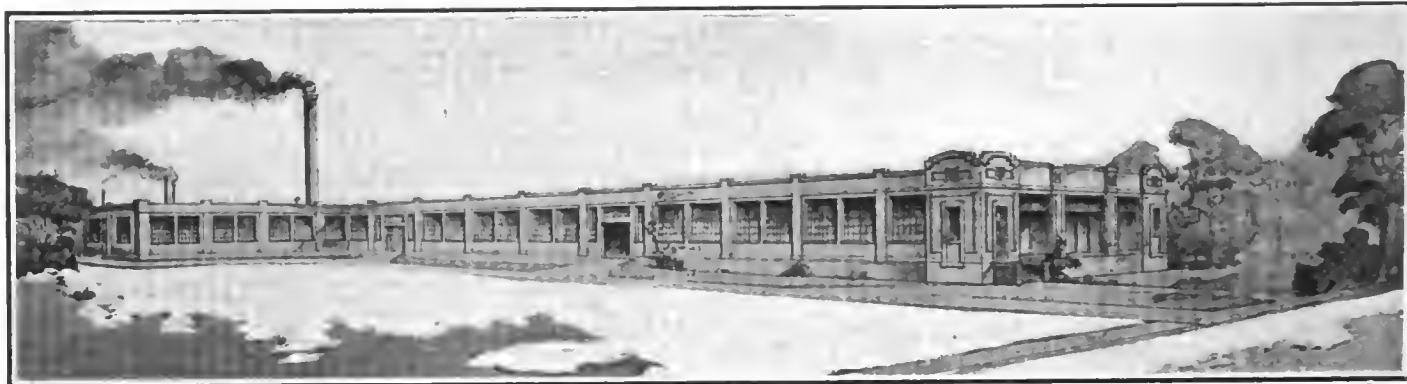

New plant of the Republic Motor Car Company at Hamilton, Ontario.

**HAMILTON, O.**—The new plant of the Republic Motor Car Company is of heavy type mill construction, with exceptionally large window space. The window frames are all steel and the entire building is absolutely fire-proof. It will be ready for occupancy January 15.

**CHICAGO, ILL.**—The Chicago Commercial Car Company is building a new factory on the North Side on the railroad and Evanston avenue. The new building will be occupied on January 1.

**DALLAS, TEX.**—The Firestone Tire & Rubber Company will open a direct factory branch in this city January 1. It will be located at 1521 Commerce street and will be under the management of Mr. P. B. Talbott.

**CUDAHY, WIS.**—The new office building of the Federal Rubber Manufacturing Co. on Layton avenue will be ready for occupancy about January 1. It is two stories high, of red press-brick construction and a model structure of its kind.

**BOSTON, MASS.**—Harry Israel, general sales manager of the O'Neil Tire Protector Sales Company of Cleveland, O., and James Watters, who is the New England representative of the firm, have been in Boston seeking a location to open a branch here.

**BROOKLYN, N. Y.**—As has been its custom for a number of years, the Moller & Schumann Company had its selling force at the factory on Monday, Tuesday and Wednesday of last week for the usual annual conference. The meeting was probably the most successful ever held.

**GRAND FORKS, N. D.**—A new Ford branch has just been opened under the name of the Ford Automobile Company. The new house will be both retail and wholesale and will have charge of the distribution of Ford cars in contiguous Minnesota and North Dakota territory.

**DALLAS, TEX.**—Following the policy of establishing branch service stations in all parts of the country, the Remy Electric Company of Anderson, Ind., has opened a service station and supply house in Dallas, Tex. The establishment will be known as the Remy Service Station and will be in charge of Mr. M. A. Price.

**BATAVIA, N. Y.**—The Batavia Rubber Co. has increased its capital stock from \$70,000 to \$500,000. Options have been secured on several large tracts of land adjacent to the factory. The new capital will be used in the extension of the company's plant, in securing additional machinery and equipment and in other ways tending toward a largely increased output. The company makes a specialty of its patented Security non-skid tire. It has added a solid tire to its line.

**MASON CITY, IA.**—The controlling interest of the Colby Motor Co., has changed hands. New officers were elected as follows: President, J. E. Burmeister; vice-president, Wm. C. Colby; treasurer, H. S. Murphy; secretary, W. N. Smith; general manager, D. W. Henry. Under the new management it is expected that the output of the factory will be increased and that the line of trucks will rapidly be completed and put on the market.

**KEWAUNEE, WIS.**—O. O. Storle, inventor of a number of mechanical appliances, such as valves, couplings, etc., has just been granted patents on a new type of gasoline engine or motor, which he will manufacture at Kewaunee. The feature of the engine is the employment of two piston heads and rods in each cylinder, which is claimed to make the engine capable of doing twice the work of the ordinary engine at the same expense for fuel. The expense of producing the engine is said to be practically equal to that of the ordinary engine.

**INDIANAPOLIS, IND.**—The Presto-O-Lite Company of this city now has agents and branches in the Hawaiian, Philippine and

West Indian Islands as well as in Canada, Mexico, Germany and Australia. These branches help to solve the shipping problem, as all steamship bills-of-lading specify that all tanks on cars being shipped shall be empty.

**CLEVELAND, O.**—A \$350,000 corporation has been organized by the Grant Lees Machine & Tool Company and the Stuyvesant Motor Car Company to manufacture the Stuyvesant automobile or rebuilt Gaeth car. The new corporation will take the name of the Stuyvesant Motor Car Company. The entire plant of the Stuyvesant Motor Car Company, now located on the West Side, will be moved to the East End within sixty days.

**TACOMA, WASH.**—Uniform prices of supplies and work are to be fixed by Tacoma automobile men, who met recently at the Chamber of Commerce and organized the Tacoma Automobile Dealers' Association, with Edwin C. Chambers as president; T. W. Little, vice-president; Harry W. Doherty, secretary and treasurer and C. L. Ross, W. W. King and E. C. Reynolds trustees. Committees were appointed to work with the association in the regulation and forming of uniform rates on supplies and garage work.

**BRYAN, O.**—Announcement is made that C. H. Bowersox, of the Bowersox Motor Sales Company, of this city, will open a sales room in Toledo for the handling of the Everitt line of cars. The sales rooms at Bryan will be retained, the company operating both places. The western half of the territory controlled by the company will be handled from Bryan, while the Toledo office will take care of the eastern territory. A manager will be placed in charge of each salesroom and Mr. Bowersox will devote his time to placing sub-agencies in the territory. Arrangements have been made whereby space will be secured in the building now occupied by the Gamble Motor Car Company on Madison avenue.

# PATENTS GONE TO ISSUE

**WIND-SHIELD**—Of the flexible type with a frame adjustable in various positions.

3. The shield (Fig. 1) comprises spaced supports connected at their lower ends by a transverse member. The supports may be adjusted longitudinally through spaced guides open above and below the supports, which are provided with means for maintaining them in different positions of longitudinal adjustment. A flexible shield is connected at one end with the member above mentioned, and is free and unobstructed above the same; a roller is mounted below the member mentioned and connected with the lower part of the flexible shield, the roller being supported by the guide supports.

No. 1,012,239—to Theodore F. Bourne, Montclair, N. J. Granted, December 19, 1911; filed, December 24, 1910.

**IGNITION SYSTEM FOR INTERNAL COMBUSTION ENGINES**—In which the spark plug terminals serve as contact makers for the ignition circuit.

1. In this system (Fig. 2) a number of cylinders with a spark plug in each are combined with a number of separate insulated conductors contained in a tube passing closely by the spark plugs and having an opening opposite each spark plug. At each opening a holder is secured to the tube, the holder containing a terminal member which makes contact with one of the conductors. Pivoted switch arms supported by the holders and in position to make contact with the spark plugs, are thereby caused to close a circuit between them and the conductor terminals.

No. 1,011,977—to Allen Loomis, Detroit, Mich., assignor to the Packard Motor Car Co., Detroit, Mich. Granted December 19, 1911; filed December 27, 1907.

**TURNBUCKLE**—Device containing arms ending in sleeves.

The turnbuckle yoke (Fig. 3) referred

to in this patent comprises an integral casting having spaced arms terminating in sleeves joining their ends. The sleeves have registering openings, and the arms have also cross bars spaced inwardly from the sleeves and provided with openings registering with the sleeve openings.

No. 1,012,008—to William F. Post, Asheville, N. C. Granted December 19, 1911; filed November 14, 1910.

**CRANKING DEVICE**—Crank for internal combustion motor containing provision against back kicks.

4. This patent refers to a device comprising a starting shaft which may be connected with the crankshaft of an engine and which is provided with a laterally projecting coupling pin. On the starting shaft a crank is loosely mounted and is provided with a sloping driving shoulder adapted to engage the pin. A ratchet mechanism is interposed between the crank and a stationary part, which mechanism permits of forward turning movement of the crank, but which prevents backward turning movement thereof. The ratchet mechanism comprises a disc mounted on a stationary part and provided with an annular row of ratchet teeth, and a spring-pressed pawl which is pivoted on the hub of the crank and engages the teeth of the ratchet.

No. 1,012,116—William Van Scoter, Buffalo, N. Y., assignor of one-fourth to William J. Hayes, Buffalo, N. Y. Granted December 19, 1911; filed February 13, 1911.

**FORCE-FEED CARBURETER**—A reciprocating member working in alignment with the supply pipe pumps the fuel into the carbureter proper.

1. The carbureter protected by this patent comprises a charge supply tube on which a carbureter casing is arranged. Through the casing extends an oil pipe which has inlet and discharge valves, and a reciprocating member aligned with the oil pipe is connected to a pipe for admitting pressure to it by a hollow flexible connection. A

second hollow and flexible connection is arranged between the oil conducting pipe and the reciprocating member which is stayed between the flexible connections by a fixed support. The member is provided with a flange in the path of which a sleeve is adjustably mounted in the fixed support.

No. 1,011,931—to Charles W. Farquharson, Chicago, Ill. Granted December 19, 1911; filed October 13, 1910.

**TIRE-INFLATER**—A tire pump which is driven by the engine to compress air for filling the tires.

1. This patent covers an apparatus consisting of a frame or casing and a driven mechanism carried by same and taking power from a driving member. This engages a driven member connected with the mechanism proper. Means are adjustably supported with respect to the driven member and engaging with the driving member at a point sufficiently removed from the point of engagement between driving and driven member, the means mentioned balancing partially the forces which tend to displace the driven member and permitting the latter to be held, by hand, in engagement with the driving member.

No. 1,012,098—to Enoch Rector, New York, N. Y. Granted December 19, 1911; filed August 3, 1910.

**BACKFIRE EXTINGUISHING DEVICE**—In which a baffle plate is used to resist the flame finding its way into the gas pipe.

2. This device comprises the combination of a supply pipe having a conically enlarged portion with an imperforate cone-shaped baffle member contained in the enlargement mentioned, the base of the baffle member being substantially flat and directed toward the point of consumption. A space is provided all around the baffle, the sectional area of this space being not less than that of the supply pipe.

No. 1,011,961—to Alexander Constantine Ionides, Jr., London, England. Granted December 19, 1911; filed December 5, 1910.

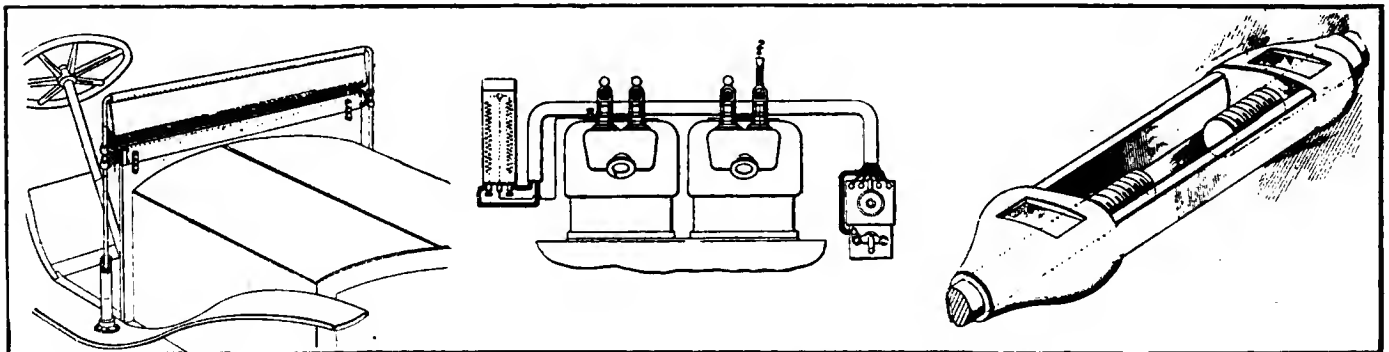

Fig. 1—Bourne windshield. Fig. 2—Loomis ignition system. Fig. 3—Post turnbuckle

# Newest Ideas Among the Accessories

## Dover Gasoline Vessels

**I**N Fig. 1 a special form of gasoline funnel, made by the Dover Stamping & Mfg. Company, of Cambridge, Mass., is shown. The funnel proper is attached to a crank-shaped filler pipe, which fits into the filler hole of any gasoline tank, so that the funnel may be put and left there while filling the tank with fuel. The funnel is heavily copper-plated and provided with brass strainers, as well as with a movable hoop to hold the chamois in place. A 4-quart funnel of this type has a top diameter of 9 3/4 inches, while the diameter of the outlet pipe is 7-8 inch.

The Duplex combination vessel, Fig. 2, does the combined work of a measure and funnel. It is a cylinder which converges slightly toward the top carrying a funnel which has a spout pointing upward. The effect of this design is that when the measure is set down all the liquid runs back into the vessel instead of dripping outside. A double pouring lip is provided, one being the end of the funnel and the other attached directly to the top of the measure, providing a fast pouring measure where vessels with large opening are being filled.

The handle being on the side increases ease of operation, and on the larger sizes—this combination measure and funnel is made in five sizes—the handles have bosses. The entire device is made of extra-heavy material and the seams are soldered and guaranteed against leak. The vessel is copper-plated and laquered. The five sizes range from 1/2 pint to 4 quarts, all being designed along identical lines, and being furnished either in polished tin, or heavy

copper-plates, or copper-plated and provided with brass strainers, to keep foreign matter from entering the tanks.

Fig. 3 shows the Dover non-evaporating gasoline measure, which is made for garage use with a capacity of 5 gallons. As may be seen from the figure, the pouring lip and filler opener in this case are one, the filler opener being in the shape of a rotary valve when in place. By turning the filler opener to a certain position, an opening in its side wall is brought to register with the pouring lip so that the fuel can be poured into the gasoline tanks without removing the filler opener of the measure. If only part of the contents of the measure is used for filling the tank, the rest is stored and kept from evaporating by so plating the filler opener in position that the interior of the tank is cut off from the surrounding air.

## E-Z-2 Work Vulcanizer

The above named product of the E-Z-2 Work Steam Vulcanizer Company, of Cleveland, Ohio, is constructed along similar lines and on identical principles with the big steam vulcanizers used in tire factories. The vulcanizer proper is a hollow brass body which is partly filled with water at the factory of the makers, and being closed hermetically never needs refilling. An alcohol lamp under the brass steam boiler provides the heat for transforming the water into steam which heats the metal wall of the brass body by contact. There is no need of watching the heating water and steam, which operation is entirely automatic, since the apparatus is self-con-

tained. One side of the brass body is curved to fit a casing, while the flat side may be applied to tubes requiring vulcanizing. A thermometer connected with the interior of the steam chamber tells the exact temperature of the metal applied to the rubber, so that with a little attention there is no chance of burning the rubber. The machine is composed of few parts, all made of highly polished, nicked brass.

## Minimax Extinguisher

Fire in the garage is the signal for cause of the destruction of a large number of high-priced machines every year and it behooves the owner of such an edifice to maintain as good a fire protection as he can possibly buy. The effects of a conflagration can never be calculated but it is true that promptness and effectiveness in the extinguishing agent is of the highest importance. These features are embodied in the Minimax, made by the Minimax Company, of Philadelphia, Pa. The acid in this device is kept in a hermetically sealed bottle and is not exposed to any other chemical until it is ready to use in a fire. A plunger is pushed in which brings the acid into contact with the soda-water, generating an acid gas which creates a pressure of 60 pounds to the square inch. The 1 1/2 gallons of liquid will perform the work of 50 ordinarily filled water pails and in the case of fires caused by gasoline or oils will have far greater effect since water is useless on a fire of this nature. The stream from the Minimax will reach a distance of 50 feet.



Fig. 1—Dover offset gasoline funnel. Fig. 2—Duplex combination vessel. Fig. 3—Dover non-evaporating gasoline measure for garages





# THE AUTOMOBILE

Vol. XXV  
No. 26

NEW YORK, DECEMBER 28, 1911

Weekly  
Price Ten Cents



**Lighting Dynamo**

This highly efficient system lights lamps, charges batteries, furnishes current for power horn. It is driven by the motor, requires no attention and only 1/6 H.P. is needed to operate it. Without question the finest system the world produces.



**Electric Lamps**

GRAY & DAVIS Electric Lamps represent the highest type of lamp beauty allied with style and correct usage. They possess the natural grace and dignity of design which we associate with an exquisite automobile.

**GRAY & DAVIS**  
Manufacturers of AUTOMOBILE LAMPS, 55 LANSLOWNE STREET

**BOSTON, MASS.**

*See Dynamo and Lamps at the Garden*



**BE SURE TO VISIT OUR EXHIBIT  
MADISON SQUARE GARDEN AUTO SHOW  
JANUARY 6-13  
OR SEND FOR THIS INTERESTING BOOKLET**



**Oilzum**  
WINS BY EVERY TEST



THE  
VANDERBILT  
CUP



THE WINNER  
Ralph K. Mulford  
USING **Oilzum**

OILZUM maintains its LUBRICATING BODY under HIGH TEMPERATURES and is the BEST REMEDY for ENGINE LUBRICATING TROUBLES; *that's why we say*



**DISTRIBUTORS**

SAMUEL WIGNEY, 3626 Mettler St., Los Angeles, Cal.  
E. J. NORRIS & CO., Sioux Falls, So. Dakota.  
KANSAS CITY AUTOMOBILE SUPPLY CO., Kansas City, Mo.  
FRANK P. FOX & CO., Indianapolis, Ind.  
MARSHALL, WOOD & RILEY CO., Plattsburgh, N. Y.  
BROADWAY AUTO ACCESSORIES STORE, Inc.,  
51-53 West 63d Street, New York, N. Y.

UNIVERSAL AUTO REPAIR CO., Hartford, Conn.  
SAMUEL WIGNEY, Metropolitan Warehouse, San Francisco, Cal.  
PLANT RUBBER CO., Minneapolis, Minn.  
THE E-M-F MEMPHIS CO., Memphis, Tenn.  
SANDERS BROS. CO., Richmond, Va.  
GREEN & SWETT CO., 737 Boylston St., Boston, Mass.  
J. C. BROWN CO., 27 Washington St., Providence, R. I.

Manufactured by

**THE WHITE & BAGLEY CO., Worcester, Mass., U.S.A.**

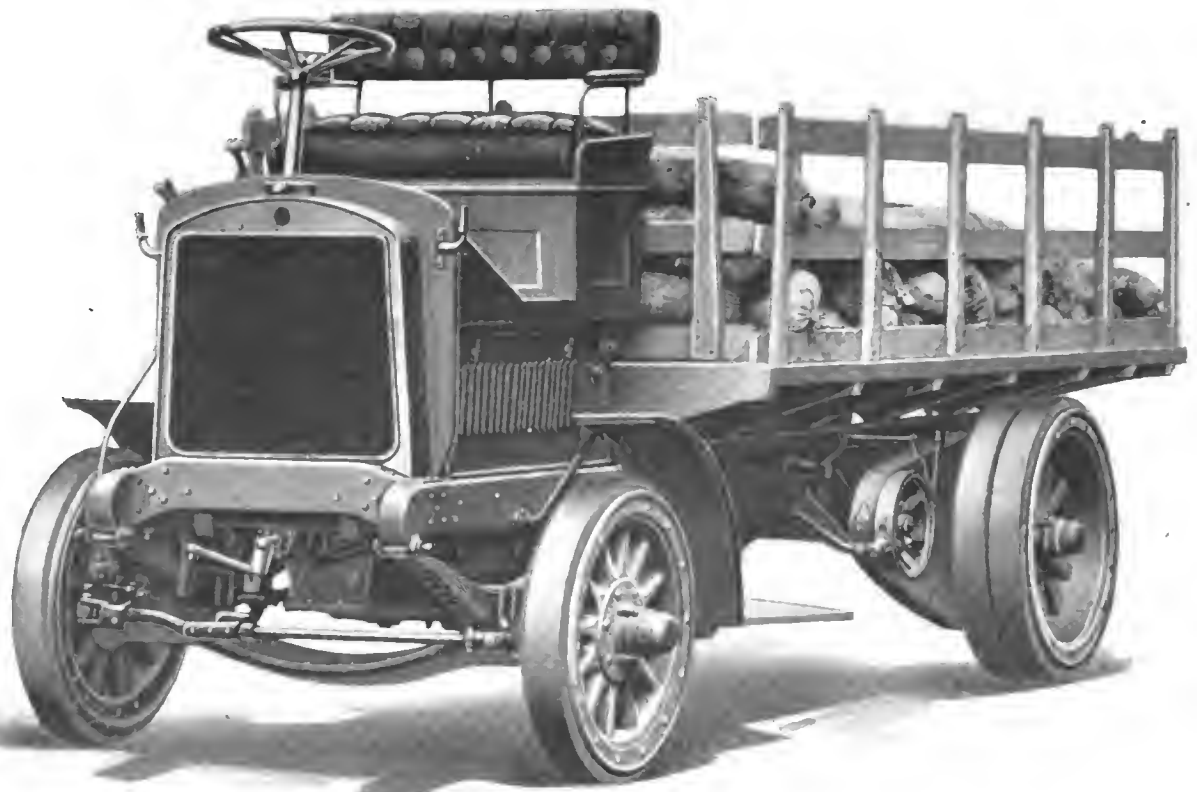

# The **LOZIER** Five-Ton Truck

The House of LOZIER in its sixteen years' successful experience in designing and manufacturing motors and motor-propelled vehicles has never marketed a mechanical mistake.

This sturdy five-ton truck is offered to the commercial world only after it has proven by road and factory tests for almost three years that it is worthy of the name LOZIER.

A book illustrating and describing this latest addition to the LOZIER line will be sent upon request.

**LOZIER MOTOR COMPANY, P. O. Box 718, DETROIT**

The agency for the LOZIER is a valuable asset.

# New DOVER Steel Thermo-Case

A Safe, Convenient and Attractive Case



For all Makes of Vacuum Bottles



Designed Especially for Automobile Use



These cases are made of steel beautifully enameled black with two narrow gold stripes. They are lined inside with double faced corrugated cardboard and form absolute protection to the bottle in automobile use.

These are the first practical low price Cases for carrying the Vacuum Bottle.

**SEND FOR NEW 1912 CATALOGUE**

Showing the Largest and Most Complete Line of Auto Gasoline Funnels and Measures.

**DOVER STAMPING & MFG. CO., Cambridge, Mass.**

## Advertisers

<b>A</b>		<b>E</b>	
Ajax-Grieb Rubber Co.....	87	E. M. F. Co.....	93
Alden Sampson Mfg. Co.....	140	Eagle Oil & Supply Co.....	77
Almond Mfg. Co., T. R.....	70	Edmunds & Jones Mfg. Co....	73
Alumaloyd Products Co.....	91	Eisemann Magneto Co.....	139
American Ball Bearing Co....	86	Electric Auto Light Co.....	87
American Lava Co.....	81	Elmore Mfg. Co.....	131
American Motore Co.....	cover	Esterline Co. ....	81
American Sales Co.....	90		
Anderson Electric Car Co....	123	<b>F</b>	
Apple Electric Co.....	106	F.I.A.T. Automobile Co.....	79
Aehton Valve Co.....	76	Firestone Tire & Rubber Co.	78
Atlas Auto Supply Co.....	77	Fisk Rubber Co.....	104
Atwater Kent Mfg. Works....	135	Ford Motor Co.....	109
Austin Automobile Co.....	143	Franklin Automobile Co.....	92
Automatic Timing Device Co.	115	Frontier Specialty Co.....	88
Automobile Supply Mfg. Co..	107		
<b>B</b>		<b>G</b>	
Baker Motor Vehicle Co.....	97	General Electric Co.....	132-133
Banker Windehield Co.....	85	General Motors Truck Co....	120
Barndt-Johnson Auto Supply Co.	76	Gibney & Bro., Jas. L.....	86
Barthel, Daly & Miller.....	89	Gilbert Mfg. Co.....	87
Beaver Mfg. Co.....	84	Goodrich Co., B. F.....	77
Blickenederfer Co. ....	81	Goodyear Tire & Rubber Co.	83
Borland-Grannis Co.....	94	Gramm Motor Car Co.....	75
Boech Magneto Co.....	99	Gray & Davis.....	cover
Bower Roller Bearing Co....	90	Great Weestern Automobile Co.	95
Bowser & Co., S. F.....	99	Groesman Co., Emil.....	82
Bretz Co., J. S.....	124-125		
Bricteon Mfg. Co.....	85	<b>H</b>	
Bridgeport Brass Co.....	85	Haberer & Co.....	101
Briggs-Detrolter Co.....	121	Ham Mfg. Co., C. T.....	102
Briggs and Stratton Co.....	85	Hardy Co., R. E.....	88
Briggs Magneto Co.....	75	Harris Oil Co., A. W.....	86
Brodeseer Motor Truck Co....	92	Hartford Suspension Co.....	112
Brown Co., Joe. M.....	90	Havers Motor Car Co.....	94
Brush Runabout Co.....	140	Haynes Automobile Co.....	93
Buckeye Jack Mfg. Co.....	78	Helnze Electric Co.....	87
Buckeye Mfg. Co.....	97	Henderson Motor Sales Co....	96
Buob & Scheu .....	75	Herreshoff Motor Co.....	97
		Herz & Co.....	105
<b>C</b>		Heee-Bright Mfg. Co.....	116
Carr Co., F. S.....	76	Hodge & Gravee Co.....	82
Cartercar Co.....	93	Hoffecker Co. ....	71
Casgrain Speedometer Co....	88	Hoffman, Geo. W.....	75
Champion Ignition Co.....	104	Horton Mfg. Co., F. L.....	89
Champion Spark Plug Co....	75	Hotel Lakewood.....	98
Chase Motor Truck Co.....	95	Hotel La Salle.....	98
Clarke-Carter Auto. Co.....	92	Hotel Martinique .....	106
Clark Motor Car Co.....	96	Hupp Motor Car Co.....	103
Cleveland-Canton Spring Co.	82	Hupp, R. C.....	91
Colby Motor Co.....	94	Hyatt Roller Bearing Co....	83
Columbia Motor Car Co.....	140		
Conn. Shock Absorber.....	84	<b>I</b>	
Continental Motor Mfg. Co..	78	Ideal Motor Car Co.....	95
Corblin Motor Vehicle Corp..	92	Ignition Starter Co.....	79
Corcoran Lamp Co.....	85	International Accessorlee Corporation .....	105
Covert Motor Vehicle Co....	89	Interstate Automobile Co..	136-137
Crow Motor Car Co.....	94		
Cullman Wheel Co.....	75	<b>J</b>	
		Jackson Automobile Co.....	93
<b>D</b>		Jacobson Machine & Mfg. Co.	83
Dayton Motor Car Co.....	140	Jeffrey Dewitt Co.....	114
Dean Electric Co.....	77	Johnson Service Co.....	95
De Tamble Motors Co.....	75	Jones Recorder .....	89
Decatur Motor Car Co.....	95		
Diamond Rubber Co.....	87	<b>K</b>	
Diehl Mfg. Co.....	87	K.-W. Ignition Co.....	103
Dietz & Co., R. E.....	88	Kamlee Co.....	100
Dixon Crucible Co., Joe.....	85	Kimball Tire Case Co.....	84
Dorian Remountable Rim....	82	Kinsey Mfg. Co.....	108
Double Fabric Tire Co.....	91	Kissel Motor Car Co.....	91
Dover Stamping & Mfg. Co...	70	Kline Motor Car Corp.....	93
Duff Mfg. Co.....	76	Knox Automobile Co.....	93

## TO INSURE SPEEDOMETER ACCURACY

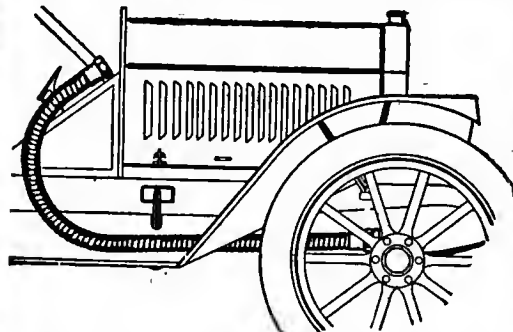

Almond Flexible Casing gives generous assistance towards increasing the efficiency of speedometers and maintaining their accuracy by affording the necessary protection to the shaft. The best speedometers are sold with an Almond Casing.

If you have shaft troubles you want our folder.

15 years manufacturers of Flexible Tubing

**T. R. ALMOND MFG. CO.**  
ASHBURNHAM, MASS.

Please mention The Automobile when writing to Advertisers

**Advertisers**

Kokomo Electric Co..... 83	<b>S</b>	Salisbury Wheel & Mfg. Co... 83
Konigslow, Otto ..... 76		Schacht Motor Car Co..... 94
Krit Motor Car Co..... 96		Searchlight Gas Co..... 87
	<b>L</b>	Selden Motor Vehicle Co..... 94
Lauth Juergens Motor Car Co. 102		Shafer Co., C. A..... 142
Leather Tire Goods Co..... 88		Shawmut Tire Co..... 78
Lenox Motor Car Co..... 95		Sheidon Axle Co..... 89
Lexington Motor Car Co..... 95		Simplex Motor Car Co..... 93
Lipman Mfg. Co..... 76		Sireno Co..... 89
Lozier Motor Co..... 69		Smith Co., A. O..... 130
Long Mfg. Co..... 90		Sonneborn Sons, L..... 101
Loveli-McConnell Mfg. Co.... 127		Spacke Machine Co., F. W.... 100
	<b>M</b>	Sparks-Withington Co..... 100
Madison Square Garden Show 134		Speedwell Motor Car Co..... 92
Manhattan Electrical Supply Co. .... 71		Spicer Mfg. Co..... 75
Marathon Motor Works..... 96		Spiltdorf, C. F..... 101
Marburg Bros. .... 88		Sprague Umbrella Co..... 107
Maxwell-Briscoe Motor Co... 140		Standard Gauge Steel Co..... 83
McFarlan Motor Car Co..... 91		Standard Oil Co..... 111
McIntyre Co., W. H..... 97		Standard Roller Bearing Co.. 76
Mercer Automobile Co..... 132		Standard Welding Co..... 122
Merchant & Evans Co..... 81		Standard Woven Fabric Co.cover
Metz Co. .... 96		Start-Lite Co. .... 76
Michener, E. S..... 90		States Mfg. Co..... 86
Moline Automobile Co..... 97		Staver Carriage Co..... 94
Monarch Mfg. Co..... 100		Stearns Co., F. B..... 92
Moss Photo Engraving Co.... 98		Sterling Machine Co..... 84
Motor Appliance Co..... 84		Sterling Mfg. Co..... 84
Motor Car Equipment Co.... 79		Stewart & Clark Mfg. Co.... 113
Motor Car Mfg. Co..... 96		Stewart Machine Wks., A. C. 89
Motz Tire & Rubber Co..... 76		Streator Motor Car Co..... 97
Muncie Gear Works..... 101		Stromberg Motor Devices Co. 117
Mutty Co., L. J..... 75		Swinehart Tire & Rubber Co. 86
	<b>T</b>	
		Thomas Motor Co., E. R..... 77
	<b>N</b>	Timken-Detroit Axle Co.... 118
N. Y. & N. J. Lub. Co..... 83		Tobey, Wm. L..... 78
National Automobile Shows.. 138		Toledo Auto Devices Co..... 85
National Motor Vehicle Co.. 99		Troy Auto Specialty Co..... 84
National Tube Co..... 83		Turnbull Wagon Co..... 81
New Departure Mfg. Co..... 129		
New Process Rawhide Co.... 81		<b>U</b>
New Process Vulcanizer Co.. 87		Union Sales Co..... 92
New York & Ohio Co..... 75		U. S. Fastener Co..... 78
Nordyke & Marmon Co..... 96		U. S. Motors Co..... 140
Northwestern Chemical Co... 75		United Rlm Co..... 82
Nyberg Automobile Works... 77		United States Tire Co..... 103
		Universal Motor Truck Co... 96
	<b>O</b>	Universal Tire Protector Co... 89
Ohio Motor Car Co..... 93		
	<b>P</b>	<b>V</b>
Packard Electric Co..... 86		Veeder Mfg. Co..... 102
Packard Motor Car Co..... 144		
Parish & Bingham Co..... 76		<b>W</b>
Pilot Motor Car Co..... 97		Wabash Cabinet Co..... 88
Pittsfield Spark Coll Co.... 108		Warner Gear Co..... 90
Premier Motor Mfg. Co..... 141		Warner Instrument Co..... 88
Prest-O-Lite Co..... 85		Warren Motor Car Co..... 91
Prosser & Sons, Thos..... 78		Western Automobile Supply
Pullman Motor Car Co..... 92		Mfg. Co. .... 90
	<b>Q</b>	Weston Elec. Instrument Co.. 79
Queen Mfg. Co..... 128		Weston-Mott Co..... 86
	<b>R</b>	White Co. .... 126
Rajah Auto Supply Co..... 78		White & Bagley Co.....cover
Rayfield Carbureter..... 84		Wilcox Motor Car Co., H. E.. 91
Reichenbach Laboratories... 86		Willard Storage Battery Co.. 110
Remy Electric Co..... 98		Willys-Overland Co. .... 119
Republic Rubber Co..... 81		Winton Motor Carriage Co... 91
Royal Equipment Co..... 90		Wisconsin Motor Mfg. Co.... 82
Rutenber Motors ..... 82		Wolverine Lubricants Co.... 77
		Wyman & Gordon Co..... 75

# COSTS MORE— WORTH MORE



A comparative test will convince any user that it is superior to all other makes.

## GUARANTEE

"We agree to CREDIT ACCOUNT, REPLACE BATTERIES OR REFUND AMOUNT paid for the batteries, including transportation charges, if they do not PROVE SATISFACTORY."

Made in three sizes. Dimensions over all: A 2 3/4 x 6 3/4—B 3 x 7 3/4—C. 3 3/4 x 8 3/4.

We are prepared to furnish all sizes in either round or square cartons as desired. For convenience and to prevent short circuits we strongly recommend the SQUARE cases.

ASK FOR PRICES AND DESCRIPTIVE MATTER

## MANHATTAN ELECTRICAL SUPPLY CO.

NEW YORK: 17 Park Place
Chicago: 1145, 5th Ave.

# HOFFECKER

*"The Steady Hand"*

Accurate



Efficient

Quiet

Speedometer

Durable

ENDORSED BY MANUFACTURERS, EXPERT DRIVERS AND OTHERS WHO KNOW

Backed By a Clean Record of DEPENDABILITY for Five Years

Satisfaction Guaranteed

PRICES—\$25 TO \$135

**Branches:**  
New York, 1779 Broadway  
Cleveland, 1217 Huron Rd.  
Pittsburg, 813 Hilland Bldg.  
Philadelphia, 408 Franklin Bank Bldg.

**The HOFFECKER CO.**  
Main Office  
Motor Mart, BOSTON

Please mention The Automobile when writing to Advertisers

# AUTOMOBILE

## Want and For Sale Columns

Twenty cents per line of not over six words.

### Cars for Sale

**A \$9,000 GERMAN MERCEDES** for \$900 Just 10% of original cost. 5-pass. touring, recent model, fully equipped and in A1 condition mechanically. Move quick. Need money. Address Box 3974, care The Automobile.

**A 1909 30-60 STEARNS** Toy tonneau; fully equipped. New tires (two extra). Car rebuilt and repainted, at \$1,250. Box 3972, care The Automobile.

**A BRAND NEW Car For Sale**—An American Tourist, type 34, 30 h.p., 4-passenger car, to be shipped from factory by May 1st, or sooner if wanted. This car will be sold at a bargain to someone, as we wish to dispose of it at once. Apply to Carl D. Sultzman & Co., Hannibal, Mo., or make an offer.

**A NEW 1912 CUTTING, model T-35.** Delivery April 1, 1912. Fully equipped. Will sacrifice my deposit of \$250 and my reservation. Box 3970, care The Automobile.

**ATLAS RUNABOUT, 110-in. wheel base,** with folding rear seat, 34x4-in. tires, in good shape; top, speedometer, etc.; car in first-class repair every way; would make good truck; price, \$400, or would trade for smaller car; cars will be demonstrated one mile or 100. H. C. Lintott, Nashua, N. H.

**AUTOMOBILES.** Save dealer's profits, buy direct from the owners. I have all makes on my lists. Runabouts from \$50 up. Touring Cars from \$100 up. Get my prices before purchasing. King, Automobile Broker, Dept. A, 217 West 125th St., New York City.

**AUTOMOBILES—Hundreds of Runabouts** —Roadsters — Touring Cars — Latest models — Guaranteed — Shipped Freight Prepaid. Write to-day for latest illustrated catalogues. The Automobile Cycle Co., Dept. BB, 1769-1787 Broadway, New York.

### BARGAINS in High-Grade Cars

45 Isotta Chain Drive, 7-passenger Quinby body with top and full equipment; driven less than 6,000 miles.

45 Shaft Drive, driven less than 1,500 miles; new Quinby equipment; 10-14 Voltu rette, a little beauty, with top.

To Close Out Less Than Bargain Prices. One new, 1911, 50 Pennsylvania, with 5-passenger Quinby body.

One new 25 Pennsylvania, with 5-passenger Quinby body.

One 50 Demonstrator, 7-passenger body, with top.

35 Simplex, with Quinby Limousine; all fine order.

J. M. Quinby & Co.,  
1706 Broadway,  
Factory,  
Newark, N. J.

**A 1912, 30-60 Toy Ton, Stearns** in perfect condition, for \$3,300; driven about 1200 miles. J. A. Forsythe, Jr., Jacksonville, Fla.

**CADILLAC, 1910 model, 5-passenger touring car,** with equipment consisting of cape top, windshield, Prest-o-lite tank, speedometer, clock, tire covers, all in good condition, including tires; car just repainted; \$800 net, f.o.b. Pittsburgh, Pa.; will demonstrate. Address C. C. McLean, Glassmere, Pa.

**CADILLAC, 1911, 5-passenger, in first-class running order,** been run 6800 miles; car has Cambridge windshield, 2 extra tires, tubes and tire covers; top slip cover, covers for lamps, Presto tank, trunk rack and tire trunk. Paint good as new; reason for selling, party has purchased 1912 Cadillac; price, \$1,400. H. C. Lintott, Nashua, N. H.

**CADILLAC, 1911; been used for demonstrating only;** car is fully equipped with top glass front, speedometer, etc., and is in perfect condition; to make room for 1912 cars quick sale price, \$1100. H. C. Lintott, Nashua, N. H.

**FORD COUPE, 2-passenger, inside drive,** nice equipment, in fine condition; just the car for winter use; can be made into a touring car also; a genuine bargain for \$485. F. W. Coffey, Lyons, N. Y.

**FOR SALE—45 horsepower, 7-passenger, Pierce Arrow touring car,** Fisk tires, magneto and full equipment, in excellent condition. \$2,500; demonstration on appointment. H. W. Longyear, 1699 Jefferson Ave., Detroit, Mich.

**FOR SALE—White steam cars;** various models in excellent condition; also parts for steamers, engines and generators. I specialize in steamers. Libal, 3145-53 N. Halsted St., Chicago, Ill.

**FOR SALE—One-ton Gramm truck, 1912 model, 30-horsepower, 4-cylinder,** used about 200 miles as demonstrator; cost \$2,000; price for quick sale \$1,500. Magna Automobile Co., Division and Railroad Sts., Holyoke, Mass.

**FOR SALE, or exchange for smaller car, 6-cylinder 1910 Welsh torpedo roadster;** run less than 200 miles. One 1908 Peerless 4-passenger roadster—a bargain. Address P. O. Box 115 Albany, N. Y.

**FULLY EQUIPPED, 5-passenger, 1910, 6-60 Palmer-Singer;** condition fine; a very fast car. Weed & Kellogg, Avon, N. Y.

**HUPMOBILE, new, 1912 model, touring car, 1 month old;** run only 50 miles; full equipment; guarantee perfect condition; will sell for \$800; want larger car. Oscar Hesse, Jr., Red Bank, N. J.

### HUDSON

When in New York come see our line of used Hudson cars. We have on hand 1910 and 1911 models of the fore-door touring, torpedo, pony tonneau and roadster types, in excellent condition and at prices which will move them quickly. The A. Elliott Ranney Company, J. A. Mellish, Used Car Dept., 1700 Broadway, New York City.

**ONE 1-TON 20 H. P. and one 2-ton 30 H. P. new auto trucks at a bargain.** Cedar Rapids Auto Works, Cedar Rapids, Iowa.

**PACKARD, 1908 Roadster, full equipment,** extra casings and inner tubes; \$1,250. Apply W. M. Outcalt, Plum and 4th Sts., Cincinnati, O.

**REO 5-passenger car, 2 cylinders, 30 h.p.,** \$275; St. Louis 5-passenger car, 4 cylinders, 30 h.p., \$350; Lambert 5-passenger car, 2 cylinders, 20 h.p., \$175; Cameron 2-passenger, 4 cylinders, 18 h.p., \$200. All equipped and in fine running order; good tires; need money; must sell. High Point Motor Car Co., High Point, N. C.

### REBUILT THOMAS CARS.

One year's work usually tells the story of the difference in construction between a high-grade, high-priced and high-powered car and those built to sell at a low first cost. The strain of gear shifting, the jar of road shocks, and the stress of brake work begin to tell on the cheaper cars. Therefore, the logical deduction is that for the man who wants a thoroughly dependable car at a moderate price the very "best buy" is a high-grade used car that has been rebuilt in the factory where it was originally made.

We have a few four and six-cylinder cars, 1908, 1909 and 1910 models, some priced as low as \$1,000. These cars should not be confused with the ordinary "second-hand" proposition, as in the rebuilding all parts which show the slightest wear are replaced by new ones. If you want a car for real work, write us and we will send you special bulletins descriptive of rebuilt cars we have on hand.

For a reasonable payment we will hold one of these cars for you for early spring delivery.

Used Car Department.

E. R. Thomas Motor Car Company.

Buffalo, N. Y.

**REO, 1910, 5-passenger touring car, been run less than 5000 miles;** has top, speedometer, etc.; tires nearly new, lights never lighted; price \$700. H. C. Lintott, Nashua, N. H.

**REO, 2-cylinder, with folding rear seat, 2 or 4-passenger car, in first-class shape,** extra top over front seat, top over rear seat, glass front; car has been through our repair shop and is in first-class repair; price, \$300. H. C. Lintott, Nashua, N. H.

**REO, 2-cylinder touring car, with top,** fully equipped, tires good as new, car in first-class repair every way; price, \$350. H. C. Lintott, Nashua, N. H.

### THE LARGEST STOCK

of Used Cars in the U. S.

Packard	Thomas	Peerless
Buick	Simplex	Pierce Arrow
Mercedes	Chalmers	Etc.
Loziers	Pope Hartfords	
Touring, Closed and Taxicabs		

at lowest prices.

Send for Price List No. 16.

Broadway Auto Exchange, L. C. Jandorf,  
1761 Broadway. Tel. Columbus 5203.

New York City, N. Y.

**STEVENS-DURYEA, 1910 Model, 6-cylinder, 7-passenger touring car, first-class condition.** Box 134, Scranton, Penna.



**TWO-TON Truck**, A No. 1 condition; also light delivery car. Frank O. Bunnell, 620 K. of P., Indianapolis, Ind.

**USED CARS** for sale—Packard seven-passenger touring cars just out of our shop; fine condition; great bargains. Meridian Auto Co., Indianapolis, Ind.

**WHAT** am I bid? Forty horsepower Overland, fully equipped, excellent condition; need money; must sell. James Marhold, 5230 24th Pl., Cicero, Ill.; phone Morton Park, 751.

**WILL SACRIFICE** my 1910 American Simplex; is in perfect condition; cost \$5,000 new. Has full equipment. Price \$1,800. W. A. Shepard, 514 West 114th St., New York.

**WILL SACRIFICE** cheap, three-seated runabout, double chain drive; would make first-class commercial delivery automobile; is now an exceptionally fine runabout; motor and tires good as new; very powerful; \$150. See Mr. Carroll, 212 East 24th St., phone 5872 Gramercy, New York

**5-PASSENGER** Interstate touring car, in perfect condition, big bargain. See Geo. Rogers, the Cigar Man, 1506 Farnam, Omaha, Neb.

**40-H.P. CASE**, 5-passenger, used 4 months, fully equipped; price, new, \$1,850; will take \$1,000. Write. Address Lock Box 195, Palmer P. O., Marquette Co., Michigan.

**50 SIMPLEX** 1910 Model. Like new. Will sell at low price to make room. J. M. Quinby & Co., Newark, N. J.

**90-H.P. Racing Fiat**; has record of mile in 35 seconds; cost \$10,000 new. Will sacrifice to quick buyer; price \$2,000. F. Goodman, 250 West 54th St., New York.

**1908 MODEL K** Stoddard-Dayton four-passenger car, in excellent condition, equipped with top, windshield, speedometer, clock, Klaxon horn, lamps, gas tank, extra tires. Price only \$700. Packard Motor Car Co. of Chicago, 2359 Michigan Ave., Chicago.

**1909 MITCHELL**, 30 H.P.; fully equipped mohair top, windshield, speedometer, Rushmore lights and generator; front tires never used, rear used very little; car just overhauled, in perfect condition; first check for \$550 takes it. The Stewart Vehicle Co., Martinsburg, W. Va.

**1911 PACKARD** 30, seven-passenger touring car, fully equipped and in the best of condition. In addition, has Klaxon horn, speedometer, and clock, dust covers, demountable rims, and is wired for electricity. Address H. M. Wick, Bradford, Pa.

**1911 ELMORE TOURING CAR**, 30 h.p., fully equipped, cost \$1,500; guaranteed fine condition; price, \$800 for quick sale; full description sent; a bargain. H. J. Daniels, Norwich, N. Y.

**Cars Wanted**

**EXCHANGE** choice farm; will take good car as part payment. W. T. Smith, Honor, Mich.

**WANTED**—1910 six-cylinder, 7-passenger "Franklin" Model H; any condition; must be cheap for cash. "H," care of Automobile.

**WANTED** to buy very cheap for cash a 1911 or 1912 model Pierce-Arrow, 48, Lozier or Alco six. Also two 5-passenger, fore-door, 4-cylinder, about 30 horsepower cars, late model, run only a short time. Address P. O. Box 505, Falls City, Neb.

**WANTED**—1911 Model G Franklin runabout. Car and price must be right. Address Doctor Franklin, 318 West King Street, Martinsburg, W. Va.

**WANTED**—Good auto in exchange for lots or acreage in Spring Valley. H. H. Sprague, 211 Am. Nat. Bank Bldg., San Diego, Cal.

**WANTED**—To exchange 40 acres Florida orange grove land for good automobile. Parties interested write P. O. Box 161, Punta Gorda, Florida.

**Parts and Accessories**

**FOR SALE**

**ALUMINUM Heel Plate**, only 50c. Prevents wearing unsightly holes in your floor covering. We are supplying thousands for 1912 cars. Just what you have been looking for. Send stamps or coin today. Money refunded if not satisfactory. Metallic Automobile Matting Co., 251 Mill St. Rochester, N. Y.

**AUTO LADIES**—Now is the time you ought to present husbands with valuable, indispensable, unique auto accessory. Write to-day to Wichita Auto Jack Co., 312 Barnes Block, Wichita, Kansas.

**ALUMINUM MATTING**. Replace that worn-out matting with Pyrrna Aluminum Matting. Send for samples, etc. Metallic Automobile Matting Co., 287, Mill St., Rochester, N. Y.

**AUTO HEEL REST**, 75c. each, prepaid. J. L. Lucas & Son, Bridgeport, Conn.

**ATTENTION**—Gentlemen's fur-lined overcoats, lined with Australian Mink, Broadcloth outside; beautiful Persian Lamb Collars; sizes 38-40 and 42-44; cost \$90 each; never worn. Will sell for \$35 each. Two elegant Cinnamon Bear robes, cost \$75; will sacrifice pair for \$30; also lady's handsome long fur coat, satin lined, never used, \$35, value \$90, and Chauffer's Siberian Dog Fur coat, new, \$30; cost \$75. Call or write E. Roberts, Room 8, 160 West 119th Street, New York.

**ADMIRAL** Automobile Primer, an instantaneous engine starter; one pull of the button and one turn of the crank starts your car on the coldest day. Price \$3.50. Satisfaction guaranteed or money refunded. Special price to the trade. For particulars address Admiral Mfg. Co., P. O. Box 253, Lincoln, Neb.

**BODIES**—We offer, subject to sale, some 4 and 5-passenger touring car and fore-door roadster bodies. Can be rebuilt to fit, and fore-doors can be added to touring bodies, if desired. Racine Manufacturing Co., Racine, Wis.

**BARGAIN** in new 4-cylinder, 3 1/2 x 4 1/2 and 4 x 5 motors. F. E. Alford, Goshen, Ind.

**E. M. F. OWNERS**—'08, '09, '10 E. M. F. owners can quiet their cars for \$1.50. Apco Valve Stem Adjusters do the work or money refunded. Order to-day. Auto Parts Co., 10 Park Place, Providence, R. I.

**EXPERIMENTAL** Motors for Sale—A leading manufacturer has for sale two six-cylinder motors built for use in the experimental department. One is of poppet valve type of original design and manufacture, the other of sleeve valve type, purchased from the English Daimler Co. These motors were used for comparative tests and are both in good condition. The experimental work on them having been completed, they are now offered for sale. Address Box 2, care The Automobile.

**FOR SALE**—One engine and generator for 1909 Model O White Steamer. Repaired at factory and put in good order. Will sell at bargain. Address P. O. Box No. 10, Indianapolis, Ind.

**FORD OWNERS**—Twenty Specialties for your car. Free catalog. Auto Parts Co., 10 Park Place, Providence, R. I.

**FORD OWNERS**—Apco Valve Stem Adjusters can be applied in an hour. Will last years. Make your motor modern. Price \$1.50 for complete set. Auto Parts Co., 10 Park Place, Providence, R. I.

**FORD OWNERS**—Gardner Truss, Gardner Auxiliary Engine Base and Gardner Quick-Attachable Ball Bearing for Ford "T" cars. Manufactured by Gardner Engine Starter Co., Inc., 1455 Michigan Ave., Chicago, Ill. Two years on the market. Carried in stock by John F. Revalk, 568 Golden Gate Ave., San Francisco, Cal.; Kansas City Auto Sup. Co., Kansas City, Mo.; Auto Parts Co., Providence, R. I.

**LOW PRICE**, good value, complete machinery, or any part, from three cars—Winton '04, Rambler '04, and a single cylinder planetary, chain drive. Any of them good for repair work, or would make nice delivery. Rutland Motor Specialty Co., Rutland, Vermont.

**HIGH QUALITY**—Guaranteed Goods at prices that talk, Dunk way pays. Do you know that your auto up-keep is from 30% to 50% too high? Then think of Dunk, because we buy by carloads, and many times entire output of factories. We own our own factory, a city block square. Money back offer if goods are not as represented makes every one of our 26,310 customers an advertisement for us. Ask any Auto fellow if Dunk way pays; ask him how much we saved him last year. A Few Bargains—more to be had for the asking: 10 Warner speedometers, \$27.50; 3510 lamps, \$2.00 up; 58 magnetos, \$18.00; 8900 battery terminals, 10 cts. dozen; 57 Cadillac rear axles, \$70.00; 58 Cadillac front axles, \$20.00; 725 3 1/2 x 4 wheels, \$3.00; 1000 \$1.00 spark plugs, 33 cts.; 67 windshields, \$25.00 kind, \$11.50; 31 Anhut radiators, \$13.50; 438 assorted mufflers, \$2.05; 32 4-cylinder motors, \$225.00; 1310 robe rails, at \$1.00; 187 foot rails; 310 tool boxes, \$2.00; 167 generators, \$3.00; 3110 32x3 tires, M. & W., G. & J., Hartford, \$6.70; 157 32x3 1/2 tires, M. & W., \$14.00; 320 Ford Model T radiators, \$18.00; 65 Ford Model N-R-S radiators, \$23.00. And thousands of other bargains. Autoparts Mfg. Co., A. O. Dunk, Pres., Detroit, Mich.

**MAXWELL OWNERS**—Apco Valve Stem Adjusters are guaranteed to make your motor quiet, worth \$15.00. Price \$1.50. Money back if not satisfied. Auto Parts Co., 10 Park Place, Providence, R. I.

**MORA REPAIR PARTS**. We have purchased the repair business of the Mora cars, including all stock on hand, drawings, patterns, jigs, office records and the right to receive the mail of the Company. Owners of Mora cars will save considerable time by placing their orders for parts directly with us. We have in stock repair parts for all models. Philadelphia Machine Works, 67 Laurel St., Philadelphia, Pa.

**REPAINT** your car yourself. With our materials and full instructions you can repaint your car as well as a regular painter and save from \$25 to \$50, depending on its size. Previous experience unnecessary. Latest colors. Write to-day for full information and color cards. We also make Liquid Gun Metal, the National Brass Enamel, \$1 a can, express prepaid. The only article of proven merit for lamps, radiators, etc. No polishing. Arsenal Varnish Co., Motor Car Dept., Rock Island, Ill.

**RELIABLE TRUCK PARTS**

- Frame with hangers, one 11-in. wheel base ..... \$3.00
- 2 Half Elliptic springs, front..... 3.00
- 2 Full Elliptic springs, rear..... 3.00
- 1 Pair Solid square axles..... 20.00
- 4 33-in. Artillery wheels, 1 1/2-in. spoke, with channels ..... 6.00
- 2-in. solid tires, fitted..... 32.00
- 1 Steering gear with control levers... 8.00
- 1 Radiator with starting crank hoie... 6.00
- 1 2-cyl. opposed water cooled motor... 75.00
- 1 Jack shaft with sliding gear transmission, 2 speed..... 40.00
- 1 2-cyl. spark coil dash..... 4.50
- 1 Carburetor ..... 5.50
- 2 Spark plugs ..... .50
- 1 Mechanical oiler ..... 3.50
- 1 Pair rear sprockets 55 tooth 1 1/2 x 1/2 with 12-in brakes..... 16.00
- 12 Feet Chain ..... 6.00

For all the above parts.....\$198.00  
We also have parts for trucks. Send us a list of what you want.

Auto Parts Company,  
517-519-521-523 West Jackson Boulevard,  
Chicago, Illinois.

**TOPS**—Until further notice, runabout tops, \$22; touring car tops, \$35. C. G. Meyer & Sons, Tiffin, O.

**WRITE AT ONCE** if you want one or forty five-passenger touring car bodies at \$10.00 each. Box 35, Industrial Bldg., Indianapolis, Ind.

**SOME RARE BARGAINS**

Which we purchased from manufacturers' surplus stock. All goods warranted first-class, and if not satisfactory you can return. Mohair touring car tops, \$13.50; roadster, \$12.50; fine tire covers, \$1.00 each; trunk racks, \$1.00; robe rails, \$1.00; foot rails, \$1.00; rumble seats, upholstered and painted, \$10.00; Gemmer steering gears, \$12.50; Ford Model T radiators, \$18.00; gas tanks, \$13.50. Autoparts Mfg. Co., Detroit, Mich.

**500 CLOSED BODIES, \$150 to \$1,200.**

All best makes, new and second hand. Fit any and all cars. Windshields, \$10. Tops, \$20 up, etc.

Broadway Auto Exchange Auditorium,  
130-136 W. 56th St., N. Y. C.

**Parts and Accessories****WANTED**

**STEAM** Auto Boilers bought, sold and repaired. Lucas & Son, Bridgeport, Conn.

**WANTED**—Limousine body to fit 1910 Stoddard-Dayton Model F. Nock Auto Co., Providence, R. I.

**Repairing**

**AUTOMOBILE PAINTING** Repairing and Overhauling. Tops—Slip Covers—Windshields. Storage—Autos to Rent. Hayes & Miller Co. (Phons 7539 Bryant), 317 W. 47th St., New York.

**AUTO CASINGS RETREADED** as follows: 30 x 3, \$6; 30 x 3½, \$7; 32 x 3½, \$7.75; 34 x 4, \$12; workmanship, material and price right a trial will convince. Jungkand & Vogler, 158 Chambers St., N. Y. City. Repairing tires since 1896.

**AUTO REPAIRING**, overhauling, painting, estimates gladly furnished. We make parts and cut gears of all kinds. A specialty made of overhauling Peerless and Packard cars. All work guaranteed. E. Adams Co., 304-306 West 49th St., New York. Phons 2149 Bryant.

**BROKEN CRANKSHAFTS**, cylinders, crankcases, flywheels, gear teeth, pistons, perfectly welded and machined ready to replace. Guaranteed and references. Machinery up to 5 tons welded. Atlas Welding Works, 74-76-78 Irving St., Rahway, N. J.

**CYLINDERS REBORED**, new piston and rings, \$10 to \$15; makes compression like new. We make or repair all makes of worn or broken automobile parts. The Everts Machine Co., Hicks St., Hartford, Conn.

**CYLINDERS REBORED**, pistons and rings fitted, \$8.00 to \$12.00 per cylinder. We make cut gears, cranks, connecting rods, etc. McCadden Machine Wks., Saint Cloud, Minn.

**SCORED CYLINDERS** repaired \$8.00 per hole by welding including grinding to make them smooth and round as before scoring. Diameters 4' to 6"—smaller bores less. Send piston with cylinder. Better than re-boring because requires no special oversize pistons and rings. References and further facts on request. Waterbury Welding Co., Waterbury, Ct.

**SEND US** Broken Cylinders, Crankcases, and other cast-iron and aluminum parts to be made good as new by welding at ¼ cost of replacement. No charge unless weld is successful. References, estimates and detailed information on request. If you have a broken part it will pay you to investigate. Waterbury Welding Company, Waterbury, Conn.

**Help Wanted**

**SALESMEN WANTED**—Experienced, energetic automobiles accessory and bicycle salesman to represent large Chicago jobbers in Northwest and South. Apply, giving full particulars and references. Box 508, care The Automobile.

**WANTED**—First-class experienced electric pleasure car salesman. Must be a hustler and competent to handle retail men. State salary wanted and references. Grinnell Electric Car Co., 16 East Atwater St., Detroit, Mich.

**WANTED**—An automobile draftsman of experience; capable of doing layout work, detailing and tracing. Reply, stating salary expected, Box 3, care of The Automobile.

**WANTED**—Several good sheet metal workers, thoroughly familiar with fender work; only high-grade men need apply. Mercer Automobiles Company, Trenton, New Jersey.

**Situations Wanted**

**AS SUPERINTENDENT** or Foreman—For years in full charge of largest automobile repair shop; desires to make permanent connection where ability to deliver the goods in the hardest proposition, as his past record will show; if you are organizing a new shop or want to reorganize your old shop, here is a man who can do it with the minimum expense and maximum results; reference and salary stated at interview. Address "Executiva," care The Automobile.

**EXECUTIVE Position Wanted**—Has been executive or manager for ten years of an automobile parts concern, which during that time has grown to be the largest in its special line in the world. Satisfactory reasons for desiring a change. Thorough knowledge of all departments of parts business. Technical graduates, engineering experience. Address Box 5, care The Automobile.

**ELEVEN YEARS** in the automobile business, machinist and engineer, expert driver; no liquor; familiar with nearly all American cars; manager of garages three years; good salesman; best of references; steady job wanted and good pay; satisfaction guaranteed; go anywhere. Address Box 4, care The Automobile.

**HAVING** sold my garage, I desire position as garage manager, salesman or foreman repair department. Am a married man, 28 years of age, of good habits and a hustler. Has good business education, with 10 years' garage experience. Am good salesman and expert repairman. C. N. Richardson, Athol, Mass.

**MR. MANUFACTURER**, I have had several years' practical experience in automobile manufacturing, superintending, buying and sales department. Open for engagement Feb 1st, 1912. Address "Hustler," care The Automobile.

**MECHANICAL ENGINEER**

With six years' experience in designing motor cars and trucks, desires change of position. Is experienced in engineering and production departments; thoroughly familiar with truck designing. Graduate engineer, at present employed, desires position of responsibility with a first-class company. Address Box 3964, care The Automobile.

**SALES MANAGER**—Practical salesman, experienced in the handling of high-class trade, desires to make change. Well acquainted with both car and accessory trades. Several years' experience handling salesmen. Address Box 512, care The Automobile.

**BRANCH MANAGER**—Several years' experience in handling both retail and territory trade. Accustomed to the handling of high and medium-grade cars. Desires of making change. Either pleasure or commercial vehicles. Address Box 514, care The Automobile.

**Business Opportunities**

**FOR SALE**—Garage business, new three-story building; good buy for the man who can stand the strain. Address B. C. Q., care The Automobile.

**MR. WIDE AWAKE**, we have an exceptional opportunity for you. We are organizing a motor company in Pittsburg district to make a medium-priced car. Our stock is to be had for \$10.00 per share. Ask for our prospectus. We want to hear from men who are experienced in all the branches of the motor industry at once. Our business will bring dividends. Palace Motor Car Co., Commonwealth Bldg., Wood St., Pittsburg, Pa.

**RESPONSIBLE** Manufacturer wanted to join me in building the best car yet in its class. Demonstrator tested satisfactorily 10,000 miles. Greatest thing in silent motors and other first-class selling features. I. X. L., care The Automobile.

**Motorcycles**

**PARTS AND ACCESSORY MAKERS**—The Motorcycle field is well worth your attention; 75,000 new machines in 1912. Leading medium, "Motorcycle Illustrated," 51 Chambers St., New York. Paid circulation over 8,600.

**Auto Books**

**DYKE'S AUTO INSTRUCTION**—A new idea of instructing you to run and repair automobiles at home—with working models (from London), charts, etc. (Indorsed by Oldfield, Duryea, Splittorf.) Send for free 32-page illustrated and interesting book. A. L. Dyke, Box 22, Roe Bldg., St. Louis, Mo.

**Auto Instruction**

**AAI** is how our students stand with auto owners. Our school is the oldest, best equipped, most practical and successful in America. Write, phone or call for particulars. Auto School of America, Dept. A., 1600 Mich. Av., Chicago. Tel. 1088 Cal.

**AUTOMOBILE INSTRUCTION**, individual road work and small group classes. Day and evening. Arrangements for out-of-town men. Booklet on request. West Side Y. M. C. A. Automobile School, 310 West 57th St., New York City. Tel. 3800 Columbus.

**KUPKE'S** Automobile School, shop practice, repair work, day and evening classes. Instruction papers free. 164 Lancaster St., Albany, N. Y.

**STEWART AUTOMOBILE SCHOOL**. "Founded on Honesty—Prosperous on Merit." Send for Booklet "A," 231 West 54th St., New York City.

**Auto Storage**

**DEAD STORAGE**, \$4.00 per month and up. Riverside Storage Warehouse, 618 W. 131st St., New York City. Phone, Morningside 1122.

**STORAGE**—\$8.00 per month and up. Paul's Steam-Heated Garage, 165th St. and Jerome Aves., New York. Phone, Melrose 2948.

**COMPLETE LIST** of New Eng. Mfrs., Agts., Elec. Charging Stations, Dealers, Garages, Repair and Supply Men. Price on application. Auto List Pub. Co., 138 Pearl St., Boston.

# THE DETAMBLE LINE

THE CARS THAT LOOK TO COST TWICE THE PRICE  
AND THE CARS THAT ARE AS GOOD AS THEY LOOK

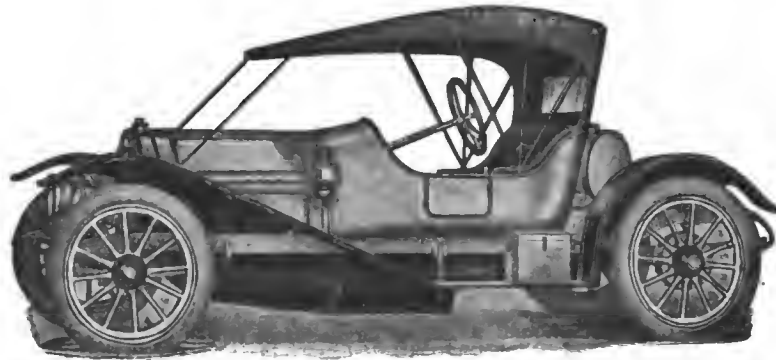

1912—Model "G" Roadster, \$1,000—1912

Catalog upon Request

A limited amount of territory still open

Bristol Automobile Co.  
Waterbury, Conn.  
Rusk & Halleck Co.  
Columbus, Ohio

GENERAL AGENTS  
Gulf Motor Car Co.  
New Orleans, La.  
J. Frank Starbuck  
Philadelphia, Pa.

L. C. Norton  
Hightstown, State of New Jersey  
So. Dakota Auto & Implement Co.  
Watertown, So. Dakota

Nicollet Ave. Auto Co.  
Minneapolis, Minn.  
Finch & Fraeman Auto Co.  
Indianapolis, Ind.

## THE DETAMBLE MOTORS COMPANY ANDERSON, IND.

### Champion Spark Plugs

Special Designs for every Type  
of Motor Made  
Catalogue Mailed on Request

CHAMPION SPARK PLUG CO.  
TOLEDO, OHIO

### OVER 1,000 GRAMMS

are now proving the superiority of Gramm  
Trucks in every state and in many foreign  
countries. They are serving nearly two hun-  
dred different classes of business.  
Write to-day for information about the  
Gramm.

THE GRAMM MOTOR TRUCK CO.  
103 So. Lima St. Lima, Ohio

### AUTO - TOP FABRICS OF EVERY DESCRIPTION

SAMPLES AND PRICES ON REQUEST

L. J. MUTTY CO., Boston

### SE-MENT-OL

ASK YOUR DEALER OR WRITE DIRECT.  
MANUFACTURED ONLY BY

The Northwestern Chemical Co., Marletta, O.



NEW YORK & OHIO COMPANY, Warren, Ohio

### AUTO TOPS

Get Our Prices. We can save you Money



BUOB & SCHEU, Court & B'way, Cincinnati, O.

### BRIGGS MAGNETO AGENTS WANTED

Every owner of a motor car equipped with the  
Briggs Magneto and Coil is guaranteed a per-  
fect working ignition system until the car  
itself goes to the scrap heap. No conditions,  
loop holes or time limits—simply all upkeep  
and renewals, if any, at our expense. Write  
for prices.

BRIGGS MAGNETO CO., Elkhart, Ind.



### METAL POLISH

Highest Award  
Chicago World's Fair, 1893  
Louisiana Purchase Exposit-  
tion, St. Louis, Mo., 1904  
San. Ex. for 10 cents  
Sold by Agents and Dealers  
all over the world. Ask or  
write for free samples.

615 P. Falls, \$1.00  
GEO. W. HOFFMAN  
Expert Polish Maker  
Indianapolis, Indiana  
Sold by Dealers  
New York City Office,  
64-66 Chambers St.

### SPICER UNIVERSAL JOINTS

DUST PROOF OIL TIGHT

SPICER MFG. CO., Plainfield, N. J.  
Franklin Peterson, 123 So. Michigan Blvd., Chicago, Ill.  
L. D. Bolton, 1810 Ford Bldg., Detroit, Mich.  
Thos. J. Wetzel, 17 West 42nd St., New York City

### CULLMAN Sprockets and Differentials

in stock and to order.  
Send for Catalog.

CULLMAN WHEEL CO.  
1247 Greenwood Terrace, CHICAGO



**START-LITE**  
 Lights your gas Lamps by the push of a button on the dash. Write for booklet.  
**Start-Lite Co.,**  
 1504 Michigan Ave., Chicago.

**All Standard Bearings**  
 are fully described in our  
**New Catalog 24A**  
 Send for it.  
**Standard Roller Bearing Company**  
 PHILADELPHIA

**EXHAUST HEADERS**  
**OTTO KONIGSLOW MFG. CO.**  
 CLEVELAND

For your next lot of  
**BODIES**  
 it will be to your advantage to see what we can do for you  
**The Barndt Johnston Auto Supply Co.**  
 COLUMBUS, OHIO

**TOP and SLIP COVERING MATERIALS**  
 of all styles and patterns  
 Manufactured by  
**F. S. CARR CO., 118 Purchase St., Boston**  
 Send for samples and prices

**BARRETT AUTO JACKS ARE DURABLE**  
 There's One in Your Tool Box for Every Car.  
**THE DUFF MFG. CO.**  
 50 Church St. New York. PITTSBURGH, PA.

**ROTARY PUMPS**  
 For circulation of Water and Oil. For Automobiles, Aeroplanes, Marine, Traction, Portable and Stationary Hydro-Carbon Motors. Write for catalog which gives detailed information.  
**THE LIPMAN MFG. CO.**  
 210 Pleasant Street, Beloit, Wis.

**THE GAS ENGINE HANDBOOK**  
 By **E. W. ROBERTS, M.E.**  
 A VERY useful manual of information about American practice in the construction and operation of stationary gas engines, for the use of the designer and engineer. Very little space is wasted on past history, for the book is of and for today. It contains many useful tables and formulas and a number of helpful drawings illustrate the text. Size, 3½ by 5¼. Pages, 264.  
 Flexible Covers One Dollar Fifty  
**THE CLASS JOURNAL COMPANY,**  
 231-241 W 39th Street, New York

**NO MORE PUNCTURES OR BLOWOUTS**  
 The trouble-proof Motz Cushion Tire is resilient as the properly-inflated pneumatic tire, traveling at moderate speed.  
**Motz Cushion Tires**  
 average better than 10,000 miles service. One set has traveled 24,000 miles. Write for booklet 56 and letters from owners of Motz-equipped cars.  
**THE MOTZ TIRE AND RUBBER CO., AKRON, OHIO**

**The Parish & Bingham Co.**  
 PRESSED STEEL  
**FRAMES**  
 WRITE FOR ESTIMATES  
 CLEVELAND, OHIO

**HIGH-GRADE Pressure Gages**  
 FOR Gasoline, Air, Water or Steam  
 ALSO Pop Valves, Water Gages and Cocks  
**THE MORTON VALVE CO., 271 Franklin St., Boston, Mass.**

**The Newest Book**  
 on  
**Aeroplanes Engines Propellers Materials, Etc.**



**SECOND EDITION—FULLY REVISED AND ENLARGED**

**THE ART OF AVIATION**  
 By **Robert W. A. Brewer**  
 Fellow of the Society of Engineers ("Gold Medallist"), Etc.  
 279 pages, 6 x 9, fully illustrated and with working drawings, \$3.50 net, postpaid

This new edition covers the enormous developments of the past year in every phase of aviation. It makes this book again the latest authority on the technical details of flying.

The author is an engineer and his work has been entirely from the technical side of the question. His book is a practical, working treatise. It presents working drawings for the construction of machines, describe engines and propellers in detail, and discusses the art of flying, including gliding experiments, steering, balancing and control. It will interest the general as well as the scientific public.

FOR SALE BY **THE CLASS JOURNAL COMPANY,** Publishers of "THE AUTOMOBILE" **NEW YORK**  
 231-241 West 39th Street

Please mention The Automobile when writing to Advertisers



# Save $\frac{1}{10}$ of Your Tire Repair Expense

For five cents you, yourself, can permanently repair any puncture—easier, quicker, and better than by vulcanizing. Even the worst blow-out—in tube or casing—can be quickly repaired with just your two hands and



Trade Mark Reg. U. S. Patent Office

It makes a permanent repair as tough and elastic as the tire itself at one-tenth the cost of vulcanizing. Use it anywhere—in the shop or on the road. Only 15 minutes to repair a puncture, an hour for a blowout.

Besides saving nine-tenths of your tire repair expense you can double the life of your carings by promptly repairing cuts and sand pockets with Tire-Doh. Prove it to your satisfaction at our risk. We refund your money upon request. Ask your dealer for a Tire-Doh Outfit today—price, \$2. Or send us \$2 and get one express prepaid. You run no risk. Money back if you ask it. Order Tire-Doh now and save money,

**ATLAS AUTO SUPPLY CO.**  
75 East Adams Street, CHICAGO

Motoring is more common today than it was five years ago, and the sale of Goodrich High Mileage Tires has shown much more than a proportionate increase . . . sufficient evidence that they are the "Best in the long run."

## GOODRICH TIRES

## EAGLEINE NO-KARBON OIL



*Mr. Autoist:*—If you are tired of buying cylinder oils advertised as "non-carbonizing" and finding same DO carbonize, just try ONE can of Eagleine No-Karbon Cylinder Oil. We will guarantee—on your own terms, if you like—that this oil cannot deposit carbon in any shape or form.

*Mr. Dealer:*—Eagleine No-Karbon Cylinder Oil is the medium for quick sales and repeat orders. Write for our Dealer's Proposition.

**EAGLE OIL & SUPPLY CO., 104 Broad St., Boston, Mass.**

WHEN WRITING TO ADVERTISERS  
PLEASE MENTION THE AUTOMOBILE

THE AUTOMOBILE CATECHISM—It Asks The Question—Then Answers It. Revised Edition, 264 pages. Bound in morocco. Price \$2.50 Prepaid. Book Dept., THE AUTOMOBILE, 231-249 W. 39th Street, New York City.

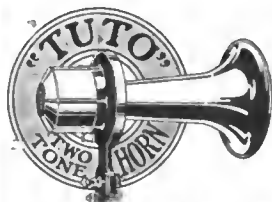

## The Tuto Coupon

Entitles you to a ten days' free trial of a TUTO HORN on your car. Look for the Tuto Coupon in our big ads in this and other publications.

The Dean Electric Co., 298 Taylor Ave., Elyria, O.  
"Look for Dean where Quality's seen"



MANUFACTURED BY  
**Wolverine Lubricants Co.**  
OF NEW YORK

SOLD BY  
PACKARD DEALERS, RELIABLE  
GARAGES, OR DIRECT FROM US

Used and Recommended by  
**PACKARD MOTOR CAR CO.**  
DETROIT, MICHIGAN

NOTHING COUNTS LIKE SERVICE

# Thomas

TECHNICAL SERVICE  
for  
THOMAS OWNERS

**E. R. THOMAS MOTOR CAR CO.**  
BUFFALO

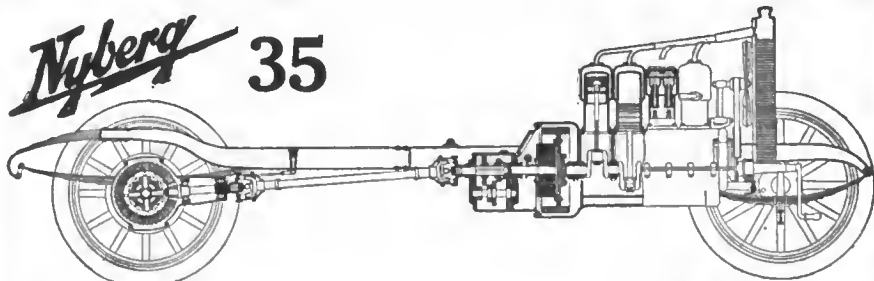

## 1912

## PRICE, \$1,250.00

**MOTOR**—4 cylinder Rutenber, 4 1/4 x 5 1/2, unit power plant, three point suspension.  
**IGNITION**—High tension magneto and batteries.  
**LUBRICATION**—Self-contained, operated by pump.  
**CLUTCH**—Multiple Disc, Raybestos lined.  
**TRANSMISSION**—Selectiva type, sliding gear, three speeds forward and reverse.  
**DRIVE**—Shaft through two universal joints and closed, running in oil.  
**REAR AXLE**—Full floating pressed steel with annular ball bearings.

**FRONT AXLE**—One piece, drop forged, very heavy steering knuckles.  
**SPRINGS**—Front: semi-elliptic; rear: 3/4 elliptic.  
**BRAKES**—Double set, both on rear wheels. 14 inch brake drums.  
**STEERING GEAR**—Worm and sector.  
**WHEEL BASE**—116 inches.  
**TREAD**—56 inches.  
**TIRES**—34 x 3 1/2.  
**EQUIPMENT**—Five lamps, gas generator, horn, tools, pump and repair kit.

WE WANT GOOD AGENTS IN EVERY PART OF THE COUNTRY  
**NYBERG AUTOMOBILE WORKS**  
CHICAGO OFFICE 2437 Michigan Ave. ANDERSON, INDIANA



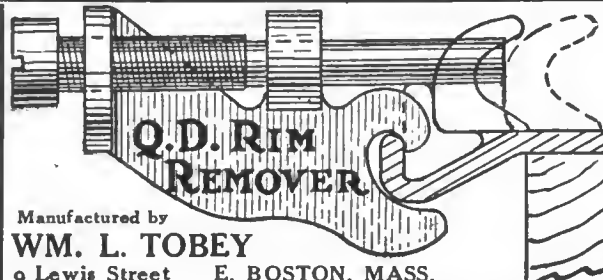

**Q. D. RIM REMOVER**

Manufactured by  
**WM. L. TOBEY**  
9 Lewis Street E. BOSTON, MASS.

Inserted at the joint of the locking ring on Universal or Fire Stone Quick Detachable Tires, will, by turning the screw, when clamp nut is removed from valve stem and stem is forced up in rim, force the clincher ring from the position in full lines over the locking ring, to the dotted position, so that the locking ring can be easily removed. This does away with the annoyance and delay usually experienced when trying to uncover the locking ring with screw driver, chisel and the usual tools found in the tool kit. When replacing the tire the inner tube can be inflated enough to be sure it is not nipping anywhere and then forced on the wheel. Nickel plated and case hardened, it weighs 2½ oz. Mailed prepaid in U. S. on receipt of 65c. (Money Order, N. Y. or Boston Draft). No stamps.



**FASTENERS**

All styles and sizes for AUTOMOBILES.  
Now used on all the leading Motor Cars.

**UNITED STATES FASTENER COMPANY**  
Manufacturers of Snap Fasteners and Metal Goods.  
95 MILK STREET, BOSTON, MASS.

Write for prices.  
Prompt Deliveries.

NEW YORK CITY 450 Broome St.  
Represented at 237 Fifth Ave., CHICAGO, ILL.

# KRUPP STEEL

**THOMAS PROSSER & SON, 28 PLATT STREET, NEW YORK CITY**

**IS NO EXPERIMENT.** It is the best that brains and years of experience can produce. Manufactured in various grades for all motor car parts. Round forged bars of chrome nickel steel grade E F 60.0 carried in stock in New York City.



## The Practical Gas Engineer

What To Do and How To Do It. A book of 150 pages neatly bound in cloth. Sent postpaid for \$1. Address Book Department The Automobile, 231-241 W. 39th St. New York.



# SHAWMUT TIRES

SHAWMUT TIRE CO. BOSTON, MASS.

# "RAJAH" SPARK PLUGS

IGNITION ABSOLUTELY SURE

**RAJAH AUTO SUPPLY COMPANY** BLOOMFIELD, NEW JERSEY  
JOHN MILLEN & SON, Ltd.      Watsessing, Station, D. L. & W. R. R.  
MONTREAL, TORONTO, VANCOUVER



Continental Model C  
Factory Representatives: K. F. Peterson, 122 Michigan Blvd., Chicago, L. D. Bolton, 1810 Ford Bldg., Detroit

**"Continental" the motor of Quality**

It adds selling value to your car

The name is Standard Everywhere

20 to 60 H. P.

Write for catalog

Continental Motor Mfg. Co.  
Muskegon, Mich.

# "Firestone" TIRES

Most Miles Per Dollar

The Firestone Tire & Rubber Co., "America's largest exclusive tire and rim makers" Akron, O.



**Buckeye Jacks**

are the best Auto Jacks for all the cars in the world. No others equal them for durability, reliability and capacity. Insist on your car being equipped with a **BUCKEYE JACK.**

MADE ONLY BY  
**Buckeye Jack Mfg. Co.**  
Allamore, Ohio

Please mention The Automobile when writing to Advertisers

ACCURACY — RELIABILITY — DURABILITY — ECONOMY  
 are assured to the greatest extent in charging  
 stations and other electric plants, by the use of the

## WESTON SWITCHBOARD and PORTABLE INSTRUMENTS FOR ELECTRICAL MEASUREMENT

These instruments represent the greatest advance thus far in the art of electrical measurement

Full information is contained in catalogs, which will be sent upon request.

New York Philadelphia Chicago Boston	San Francisco St. Louis Denver, Cleveland	New Haven Birmingham Mexico Montreal	Toronto London Paris Berlin	<b>WESTON ELECTRICAL INSTRUMENT COMPANY</b>  NEWARK, N. J.
---	--	---	--------------------------------------	--

# FIAT

**"THE MASTER CAR"** **FIFTEENTH YEAR**

35 H. P., \$4,500, Open Bodies; \$5,500, Limousine Bodies  
 (Completely Equipped)

*The Fiat Agency Policy is One of Permanency*

**F. I. A. T.** **NEW YORK**

POUGHKEEPSIE

### The Automobile Handbook

A practical book for owners, operators and mechanics. Includes road troubles, motor difficulties and other contingencies and how to handle them. By L. ELLIOTT BROOKS. 320 pages. Numerous illustrations. Full leather, limp. Price, \$1.50. Address The Automobile, 231-241 West 39th Street, New York.

### Induction Coils

Gives easily understood explanations of the operation of coils. Of great value to the autoist. By H. P. NORRIE, 265 pages. Numerous illustrations. Cloth bound. Price, \$1.00. Address, The Automobile, 231-241 West 39th Street, New York.

# THIS OR THIS?

**The Driver Turned to Look Back.**—Near San Rafael, Cal., the driver of a car containing four women turned to look back. The car left the road, overturned, killed one woman, and painfully injured the others. The car was completely wrecked.



**Argos Mirror**

See what's coming without turning "to look back."

With Hood, \$7  
Without Hood, \$6

*Get one to-day before YOUR driver turns "to look back."*

**MOTOR CAR EQUIPMENT COMPANY, 55a Warren Street, New York City**

# The DISCO SIMPLE AND SURE

SELF STARTER

The extreme simplicity and absolute reliability of the

## Disco Starter

explains its adoption by the experts of the motor car world.

**THE IGNITION STARTER CO., 711 Ford Bldg., Detroit, Mich.**  
*Largest Manufacturers of Self-Starters in the World*



THE ARISTOS CO., EASTERN DISTRIBUTORS: West 54th St., NEW YORK; 1002 Boylston St., BOSTON; 649 N. Broad St., PHILADELPHIA; 211 Fourth Ave., PITTSBURG; J. H. Palmer & Co., 321 Rookery, CHICAGO; John R. Ball, 41 Patton Bldg., MILWAUKEE; J. T. Fisher, Memphis Motor Co., MEMPHIS; Disco Anto Starter Co., 815 Huron St., Toledo; McCrae-Whirl Co., 2045 Euclid Ave., CLEVELAND; J. B. Freund, BUTTE, Mont.; F. S. Wlemeyer, 3134 Park Ave., ST. LOUIS.

Please mention The Automobile when writing to Advertisers

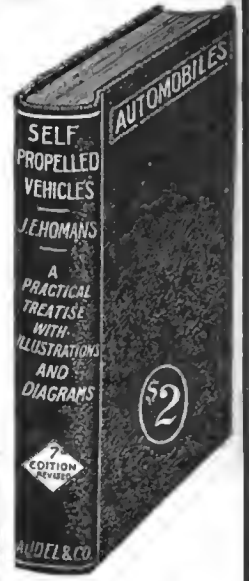
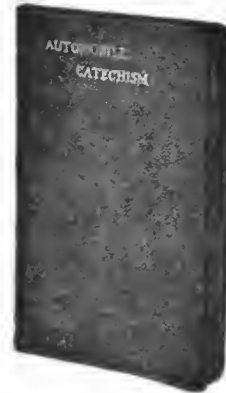
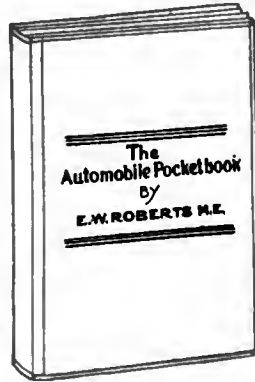
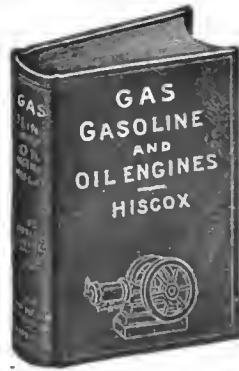

# BOOKS OF INTEREST TO THOSE WHO USE AUTOMOBILES



**Audel's Answers on Automobiles** enables you to get more and better service and longer life from your car. Contains 512 pages. Fully indexed for ready reference. 380 illustrations. Written so clearly and simply anyone can understand it. By mail \$1.50.

**Automobile Driving Self Taught.** An exhaustive treatise on the Management, Care and Operation of Motor Cars. Pocket size, 230 pages, illustrated. Price, \$1.50.

**Ignition, Timing and Valve Setting.** Pocket size, 225 pages, fully illustrated. A comprehensive illustrated manual of self instruction for Automobile Owners, Operators and repairmen. Price, flexible leather, \$1.50.

**Gas Engine Manual.** Gives the latest and most helpful information respecting the construction, care, and management of gas, gasoline, and oil engines. Each chapter is illustrated by diagrams. Contains 512 pages, 156 drawings. Price, \$2.00, postpaid.

**Gas, Gasoline and Oil Engines.** A practical work on gas, gasoline, kerosene, and crude petroleum engines and producer gas plants. Pages, 442. With 351 illustrations. \$2.50.

**The Automobile Pocket Book.** The purpose of the author in writing this book has been to place before the designer and operator, in a concise manner, a few general notes on the design and operation of the gasoline automobile. Size, 3 1/4 by 5 1/4. Pages, 329. With many drawings. \$1.50.

**The Automobile Catechism.** Treats of the automobile in modern form and of all of its troubles that may be remedied by the driver. IT ASKS THE QUESTION—THEN ANSWERS IT. Revised Edition, 264 pages. Bound in Morocco. Price, \$2.50, prepaid.

**Self-Propelled Vehicles.** A practical treatise on the theory, construction, operation, care and management of all forms of automobiles, with upwards of 500 illustrations and diagrams. Size, 5 1/4 by 8 1/4. Pages, 652. With drawings and half-tones. Cloth bound, \$2.00.

**Automobile Handbook.** Written to supply practical information to automobile owners, operators and the automobile mechanic. Subjects arranged alphabetically. Size, 4 1/4 by 6 1/4. Pages, 320. Over 100 illustrations. Full leather. Limp, \$2.00.

**Induction Coils.** A practical work on how to make, use and repair coils. Size, 4 1/4 by 6 1/4. Pages, 289. With 78 illustrations. Cloth, \$1.00.

**A.B.C. of Motoring.** A manual of practical information for layman, auto novice and motorist. Also contains digest of motoring laws of thirty-five States and names of those having no laws. Morocco cover, \$2.00.

**Automobile Motors and Mechanism.** Pocket size, 265 pages, blue flexible leather, round corners, red edges, fully illustrated. Price, flexible leather, \$1.50.

**The Practical Gas Engineer.** A manual of practical instruction on stationary internal combustion engines. Size, 4 by 6 1/4. Pages, 143. Cloth boards, \$1.00.

**Automobile Troubles and How to Remedy Them.** Pocket size; 5 x 7 inches, 252 pages, illustrated, handsomely bound in red flexible leather, round corners, red edges. The only book of its kind published. It not only tells you how to locate troubles and make repairs, but shows you. Price, flexible leather, \$1.50.

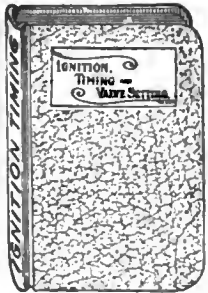
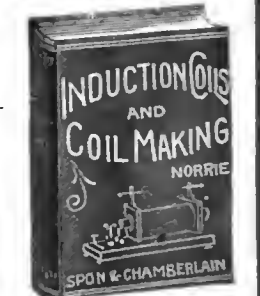
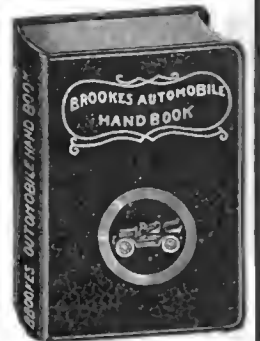

Any book sent postpaid on receipt of price

## The Class Journal Company

231-241 West 39th Street

NEW YORK

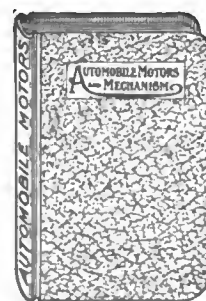
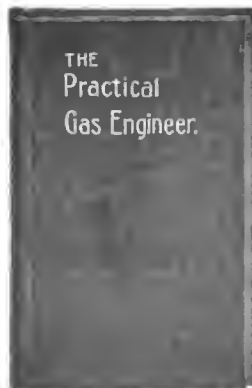
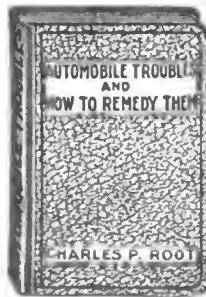

Please mention The Automobile when writing to Advertisers

# Gear Repairs For Quik Delivery

Our facilities are second to none for turning out the highest class of automobile gears. Let us help you on your rush work.

The **NEW PROCESS**  **RAW HIDE CO.**  
OFFICE & WORKS SYRACUSE, N. Y.

# YOU WILL FIND THESE SUPERIOR FEATURES

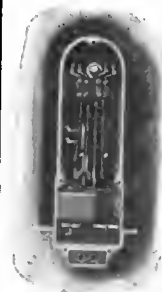

Only in the **BERDON ELECTRIC LIGHTING SYSTEM**

- (1) The current from the dynamo is automatically increased when the lights are turned on. (Always keeps the battery charged.)
- (2) Dynamo current is automatically reduced when lights are turned off. (Battery is not harmed by overcharging.)
- (3) The automatic regulation is accomplished without any moving part whatever.

Bulletin 1500-A tells how.

The Controller that has made the friction governor a back number.

**THE ESTERLINE COMPANY**  
LAFAYETTE, INDIANA



When Buying  
Burners  
Say—

TRADE MARK  
**ALCO**  
GERMAN  
LAVA  
BURNERS

**AMERICAN LAVA CO.**  
P. J. KRUESI Sales Manager Chattanooga Tennessee



# Bulls Eye Spark Plug "The Plug With the Crystal Ports"

Shows at a glance dead cylinders and imperfect combustion. Aside from special features the best made spark plug on the market. Ports guaranteed against breakage. Order a set from your dealer or from us. \$1.25 each, charges prepaid on receipt of price.

**G. C. BLICKENSERFER CO.**  
STAMFORD CONN.

**THE AUTOMOBILE POCKETBOOK.** By E. W. Roberts, M.E. This is a very complete little book, dealing with the automobile in its modern forms. It was written by a practical man for practical men, and contains a great deal of valuable information. The style in which the Automobile Pocketbook is written is concise and to the point, there being no unnecessary verblage, so that although small in size, the volume will be much appreciated by those looking for real practical information. It is one of the best pocketbooks. Size, 3½ inches by 4¼ inches. The book contains 319 pages, many interesting illustrations, and is carefully indexed. Bound in leather. Charges prepaid, \$1.50. Address **THE AUTOMOBILE**, 231-241 W. 39th St., New York.

# EQUIP YOUR CAR WITH

## STAR TIRE AND TOOL CASE

A distinct departure from the ordinary unreliable tire case—and the "last word" in improvement. This case is made of thin but rigid steel—is waterproof, dust-proof and cannot be broken into by thieves. Compact, solidly constructed and will not rattle. Carries spare shoes, tubes, small tools and spare parts. Price F. O. B. at factory, \$25. Get catalogue 8.



**MERCHANT & EVANS CO.**

PHILADELPHIA  
Chicago, Denver, Kansas City, New York, Brooklyn, Baltimore.

# REPUBLIC

**STAGGARD TREAD TIRES  
WILL NOT SKID**

For negotiating slippery streets and roads; for safety on short turn; for perfect traction in hill climbing; for resiliency; for long wear; for thoroughly satisfactory every-day service—insist on your car being equipped with

**REPUBLIC STAGGARD TREAD TIRES**

"The Tire Perfect," a book on tire service and tire economy, sent on request

**THE REPUBLIC RUBBER CO., YOUNGSTOWN, OHIO**  
Branches and Agencies in all principal cities



# DEFIANCE KEYED ARTILLERY WHEELS

Patented June 27, 1910, No. 96807

**THE WHEEL WITH A REPUTATION**

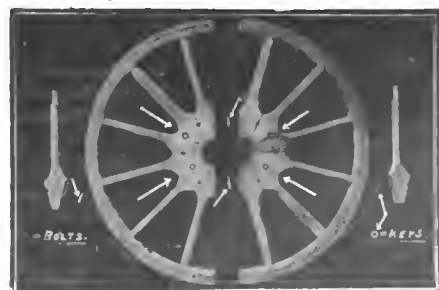

NOW IN USE ON MANY OF THE BEST CARS ON THE MARKET

THE WHEEL FOR THE MANUFACTURER WHO IS LOOKING FOR QUALITY

**THE TURNBULL WAGON CO.**

**DEFIANCE, OHIO**



# STRENGTH

from Chrome Vanadium Steel costing us many times ordinary steel prices; oil tempered, not merely flashed in oil or chilled in water, the old wrong way for tempering. Tested physically to withstand 40 tons to the square inch without taking a permanent set, there is no equal to **Cleveland-Canton "Chrome Vanadium" Automobile Springs**

Combine flexibility and strength to best meet all strains, jars or vibration from load, road, or engine. For Motor Trucks, Tractor Engines, Auto Cabs and all Motor Vehicles. Give Longest Service and **SAFETY**  
 Best Grade: "Chrome Vanadium." Next Best: "Special Analysis."  
**THE CLEVELAND-CANTON SPRING CO. Canton, Ohio 23**

Two Turns  
L  
O  
C  
K  
S



**Standard Universal Demountable Rims**

Two Turns  
U  
N  
L  
O  
C  
K  
S

the Rim in Place      the Rim for Demounting

The United Rim Co      Akron, Ohio

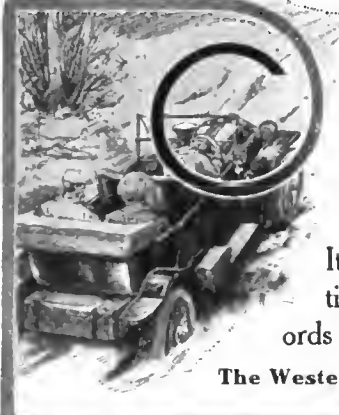

No road too rough, no hill too steep for the car that carries

## THE RUTENBER MOTOR

It has made more reputations and broken more records than any other motor.

The Western Motor Co., Marion, Ind.



### You shouldn't expect good service

from an automobile, motor boat or motor-cycle if you handicap it with poor spark plugs.  
 Let the **Red Head**

do your sparking and 'twill be done well and economically.  
 All Sizes—All Styles—All Dealers—\$1.00  
 See our exhibit, space 625-626 Madison Square Garden Show, Jan. 6 to 20, 1912.

**Emil Grossman Company**  
 250 West 54th Street      New York City  
 Factory & Western branch, 844 Woodward Ave., Detroit.

## Patent Luxury Folding Seats



Made from steel drop forgings; artistic in design and finish; compact, rugged and durable.  
 A necessity of high grade car equipment. Write for catalog showing various models.

**HODGE & GRAVES CO.**  
 AMESBURY, MASS.

## The Practical Gas and Oil Engine Hand-Book

**A** MANUAL of useful information on the care, maintenance and repair of Gas and Oil Engines. This work gives full and clear instructions on all points relating to the care, maintenance and repair of Stationary, Portable and Marine Gas and Oil Engines, including How to Start, How to Stop, How to Adjust, How to Repair, How to Test, Pocket size, 4x6 1/4, 200 pages. With numerous rules and formulas and diagrams, and over 50 illustrations, by L. Elliott Brookes, author of the "Automobile Hand-Book." This book has been written with the intention of furnishing practical information regarding gas, gasoline and kerosene engines, for the use of owners, operators and others who may be interested in their construction, operation and management.



**Price \$1.50**

Edition de Luxe, Full Leather Limp.

**The CLASS JOURNAL COMPANY, 221-241 W. 39th St., New York**

## EQUIP YOUR CAR NOW WITH

# DORIAN REMOUNTABLE RIMS

(On Again—Gone Again—DORIAN)

They avoid tire-changing delays on the road. Safe, reliable and efficient.

To SEE a DORIAN demonstration is to REALIZE YOUR NEED for DORIANs.

Write today for booklet, prices and information.

**Dorian Remountable Rim Company**  
 Dept. 2, 1804 Broadway  
 NEW YORK



Here is a motor designed just the way you want it—it has distinctive features of construction that increase its efficiency and durability.

The crankshaft is of large diameter—a self contained oiling system supplied by a gear pump through the hollow crankshaft provides perfect oiling. The extra large bearings reduce friction to a minimum and increase durability. Double ignition system—magneto or battery or both.

5 Types—4 Cycle

- 3 1/2" bore, 5" stroke, 4 cyl., 25 to 30 H.P.
- 4 1/2" bore, 5" stroke, 4 cyl., 30 to 35 H.P.
- 4 1/2" bore, 5" stroke, 6 cyl., 45 to 50 H.P.
- 4 1/2" bore, 5 1/2" stroke, 4 cyl., 40 to 45 H.P.
- 5 1/2" bore, 7" stroke, 4 cyl., 50 to 55 H.P.

**Wisconsin Motor Mfg. Co.**  
 Dept. 28.      Milwaukee, Wis.

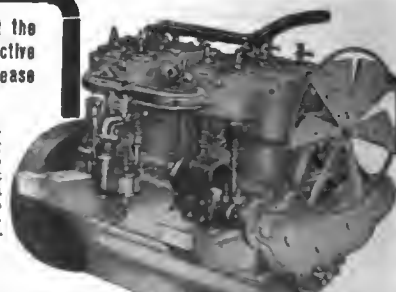

## Wisconsin Motors

Please mention The Automobile when writing to Advertisers



### FINISHED CRANK SHAFTS COMPLETE CONNECTING RODS COLD DRAWN STEEL SHAFTING

Screw Stock, Flats, Squares,  
Hexagons and Special Shapes

**FINISHED MACHINE KEYS      MACHINE RACK**

*All Material Finished to a Superior Degree  
of Accuracy*

**STANDARD GAUGE STEEL COMPANY  
BEAVER FALLS, PA.**



Will not give trouble by hardening in cold weather like grease or oil.

**TRY A CAN NOW**

But be sure to look for above trade-mark on it.

**N. Y. & N. J. LUBRICATING CO.  
165 BROADWAY, NEW YORK**

### HYATT HIGH DUTY TYPE

**ROLLER BEARINGS**  
are made from an alloy steel with a very high elastic limit, making them capable of meeting severe conditions better than any other bearing.



**HYATT ROLLER BEARING COMPANY  
DETROIT :: :: MICH.**

### Specializing Light Commercial Vehicle Parts

**REAR AXLES      FRONT AXLES  
PROPELLER SHAFTS**

**JACK SHAFTS      HUBS AND WHEELS**

Salisbury Wheel and Manufacturing Co., Jamestown, N. Y.

Peru Auto Parts Manufacturing Co., Peru, Ind.

Greenville Metal Products Co., Greenville, Pa.

All correspondence addressed to

**S. H. PENFIELD**

General Sales Mgr.,

**JAMESTOWN, N. Y.**

### Repair Inner Tubes With Ease and Speed

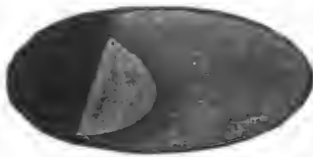

The Goodyear Self-Cure Repair Outfit offers the easiest, quickest and surest method of repairing inner-tubes. Simply clean the surface of the tube. Wash the raw gum surface of the Self-Cure Patch and stick it on. It sticks tight. The heat generated by friction within the tire vulcanizes the raw gum to a certain extent. Another good, tight-sticking patch is the White Seal Inner Tube Patch. Permanent repairs by vulcanizing by the acid process is the mission of our Acid-Cure Repair Outfit. Quick, permanent repairs can easily be made. Another convenient repair outfit is our No. 2 Outfit. This is used for repairing punctured tubes. Our No. 5 Outfit is of equal efficiency and convenience.

#### Other Goodyear Accessories

Inside Tire Protectors, Rim-Cut Patches, Lever Handle Grips, Inner Tube Bags, Quick Repair Gum, Protection Patches, Sifter Top Talc Tubes, etc. [246]

**Dealers, Repair Men, Garage Men!** For trade prices, write today to

The Goodyear Tire & Rubber Co., Freedom St., Akron, Ohio  
Branches and Agencies in 103 Principal Cities



**AIR COMPRESSORS FOR PRIVATE & PUBLIC GARAGES  
SINGLE & DOUBLE CYLINDER  
AIR OR WATER COOLED TYPES**

**JACOBSON MACHINE MFG. CO.**

**Warren, Pa.**

HASTINGS & ANDERSON CO.  
CHICAGO, ILL.  
Western Representatives



For the convenience of customers desiring immediate delivery, stocks of Shelby Seamless Steel Tubing are kept in many large cities; the location of stock nearest to any specified point will be given on request.

**NATIONAL TUBE COMPANY, General Sales Offices: Frick Building, Pittsburgh, Pa.**  
DISTRICT SALES OFFICES: Atlanta, Chicago, Denver, New Orleans, New York, Philadelphia, Pittsburgh, St. Louis, Salt Lake City. Pacific Coast Representatives—U. S. Steel Products Co., San Francisco, Seattle, Portland, Los Angeles.  
Export Representatives: U. S. Steel Products Co., New York City.

### IGNITION DEVICES

**RELIABLE, DURABLE, ECONOMICAL.**

For ten years we have been making magnetos, coils, switches spark plugs and other ignition devices that have always given satisfaction.

*Our experience may be valuable to you.  
Let us help you solve your ignition problems.*

**KOKOMO ELECTRIC CO., KOKOMO, IND.**

Know the time all the time when driving. Get the

# TIME CLUTCH

It keeps the time of day right where you can see it without taking your eyes off the road for an instant. It can be attached to any steering wheel and takes any man's watch. Watch can be inserted and removed instantly. Let us send you one and if it is not satisfactory, return it and we will refund your money.

**TIME CLUTCH:** Nickel, \$1.00; Polished Brass, \$1.00; Gun Metal, \$1.50. **VIBRATION-PROOF WATCH,** guaranteed for 1 year: Nickel, \$1.50; Gun Metal, \$2.00. Sent postpaid upon receipt of price if your dealer cannot supply you.

**THE STERLING MFG. CO., Inc.,** Staunton, Virginia

# OUR SPECIALTY

The manufacture of hardened and ground steel parts.

Emergency orders given special attention.

May we send samples of our work? Let us have your prints for estimating.

**THE STERLING MACHINE CO.**

NORWICH, CONN.

# Light Trucks in Demand

Indications point to only 30,000 commercial cars as the output for 1912, yet the market is larger and surer than the pleasure car market. Insure your dividends by offering a light four cylinder truck— $\frac{3}{4}$  to  $1\frac{1}{2}$  tons—equipped with the

# Beaver "Four" Unit Power Plant

Its long stroke ( $3\frac{3}{4}$  x 5 inches), large valves and liberal dimensions make it especially desirable because of its power at low speeds and its ability to stand up under hard use. Enclosed valves, gears and fly wheel give the finished appearance, quiet and cleanliness that are characteristic of the most advanced commercial cars. Write for catalog of other motors and prices.

**BEAVER MFG. CO.,** 2900 First Ave., MILWAUKEE, WIS.

# CONNECTICUT

# SHOCK ABSORBERS



SECTIONAL VIEW.

"Make Every Car a Parlor Car"

Send for Catalog No. 73

**CONNECTICUT Shock Absorber Co., Inc.**  
MERIDEN, CONN.

# HAVE YOU ONE

If not now is the time to try the most effective signal at a low price. The volume of its sound is loud enough to make it compare with that of any electric signal on the market.



"The Warning Courteous"

Can be installed in 15 minutes.

Furnished complete, \$5.00 or \$7.00.

**TROY AUTO SPECIALTY CO.**  
TROY, N. Y.



# All That Is Practical

CAN BE DONE ON THE M. A. C. STEAM VULCANIZER

Your shop boy can make \$1.00 each hour repairing inner tubes—relining casings—and vulcanizing surface cuts on casings. The M. A. C. is portable—compact—low in cost. Used where needed in shop or street.

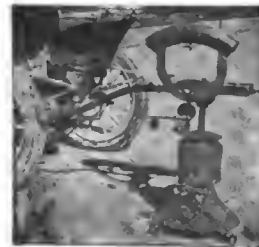

**MOTOR APPLIANCE CO.**

1304 Bellefontaine  
Indianapolis Indiana

# RAYFIELD



The BETTER CARBURETOR

**FINDEISEN & KROPF MFG. COMPANY,**  
21st and Rockwell Streets, CHICAGO

HANG ON TO YOUR OLD TIRES  
THEY CAN BE USED FOREVER  
WHEN COVERED WITH  
STEEL



The KIMBALL STEEL PROTECTOR makes BLOW OUTS, PUNCTURES, and RIM CUTS impossible. A few sections will hold any old blowout. Tires are as flexible as ever. Send for detailed information.

**KIMBALL TIRE CASE CO.,** 171 Broadway, Council Bluffs, IOWA

# The Prest-O-Lite Co.

manufacturers Prest-O-Lite, "The Light Universal," Prest-O-Starter, that eliminates the crank; Prest-O-Tire Tubes, that displace the pump; Prest-O-Tire Tanks; Prest-O-Carbon Remover and the Prest-O-Welder. Ask for information and literature for any or all of them.

**The Prest-O-Lite Company**  
234 East South Street  
INDIANAPOLIS, INDIANA

# Food for Autos

Lubrication is to the motor car what nourishment is to the human body. Both require the proper diet to do their best work. Each of the many

## Dixon Motor Lubricants

is carefully prepared to meet some particular need of the motor car, and fill that need as only a flake graphite lubricant can. Write for free sample and booklet No. 9-G.

**JOSEPH DIXON CRUCIBLE CO.**  
JERSEY CITY, N. J.



They are better than any other shield made by anyone.

Used as regular equipment for 1912 by Peerless Motor Car Co. F. B. Stearns Co.

Insist on your car being equipped with a **BANKER**

Being "Tailor-made" they will fit your individual car.

NOT HOW CHEAP, BUT HOW GOOD

Banker No. 6 Rain Vision with Ventilator  
**Banker Wind Shield Co., Pittsburg, Pa.**

# ATLAS

## AUTO PUMP

Price without Gauge \$4.00

Price with Gauge \$4.00

Made by Bridgeport Brass Co.

**YOU MUST have a reliable Pump**— a pump that inflates your tires easily and quickly and with little effort. The ATLAS pump is guaranteed. If your dealer doesn't carry it we will send the ATLAS prepaid on receipt of price.

**BRIDGEPORT BRASS COMPANY**  
102 Crescent Avenue :: Bridgeport, Conn.



## 10,000 Miles

WITHOUT A SINGLE REPAIR OR ADJUSTMENT.

This is one of the many good records made by the

### Briggs & Stratton Igniter

**It Sparks** { Every Cylinder Every Time At Every Speed

The customer who made this 10,000 miles did not touch his igniter except to clean the platinum points twice. He used no other ignition, and his igniter is just as good to-day as the day he bought it.

It will run a car 2 to 3,000 miles on one set of dry batteries or one charge of a storage battery. Write for Catalogue. Briggs & Stratton Co. 370 Milwaukee, Wis. Milwaukee St.

# The GASIFTER



The Gasifter acts as a gasoline sifter by passing the vapor and air mixture forcibly through four different brass screens, then thoroughly sifting and breaking up the globules of gas and delivering at the cylinders.

A perfect gas mixture of even density at all speeds. The Gasifter has no revolving parts and is the most simple and efficient accessory ever put on the market. It keeps the engine clean, fouling of valves is prevented on account of the perfect mixture produced by the Gasifter.

It also insures extra mileage to the gallon.

Made in many sizes to fit all makes of cars. Easily attached. Sold for \$2.00. Send for Booklet.

**THE TOLEDO AUTO DEVICES CO.**  
710 GARDNER BUILDING, TOLEDO, OHIO

# TIRE PROTECTION WITH A GUARANTEE

OF

**~10,000 MILES~**

Write for our guarantee, and catalogue, "The Enemy of Tire Expense"

Please give dealer's name.

**BRICTON MFG. CO.**

2121 Brickson Bldg., Brookings, S.D.

# Corcoran Lamps

GAS, OIL, AND ELECTRIC

CORCORAN LAMP CO.  
CINCINNATI, O.

# American

## AXLES



Write today for our Booklet.

**AMERICAN BALL BEARING CO.**  
CLEVELAND, OHIO

## EVIDENCE

proves this case—all blow-outs and 90% of punctures in Automobile Tires can be prevented with

### Auto Puncture-Proof Casings

We have facts to prove this. Try a set of these casings. If they do not eliminate all blow-outs and 90% of punctures, you can have your money back.



Write for Booklet "How to Reduce Your Tire Expense."

**STATES MFG. CO.**  
1027-1028  
W. Adams Street,  
CHICAGO, ILL.

# Swinehart

## Tires

*Investigate Swinehart Tires—pneumatic and solid truck types—and you will understand the loyalty of the vast army of car owners to whom Swinehart spells the maximum of tire service, tire mileage, tire economy.*

**The Swinehart Tire and Rubber Co**  
16 North St. Akron, Ohio  
Branches and Distributing Agencies in All Principal Cities

# Packard

## CABLE

**IS THE STANDARD OF THE WORLD FOR IGNITION and ELECTRIC LIGHTING SERVICE**

The choice of all users and of the discriminating manufacturers. A distinct line for each requirement. Want samples?

**The Packard Electric Co., 302 Dana Ave., Warren, O.**

## BEST FOR YOUR ENGINE!

# HARRIS

TRADE MARK—REG. U.S. PAT. OFF

# OILS

are good lubricants. The soot deposit elements are eliminated to the greatest possible extent. HARRIS OILS last longer because they have "body." They reduce friction and flow freely.

**A. W. Harris Oil Company**  
326 South Water St. PROVIDENCE, R. I.      66 Wabash Avenue CHICAGO, ILL.



# Axles

Hubs — Rims — Jackshafts

After thirty years of progress and growth we now have the largest axle plant in the world. The best materials—best equipment and best manufacturing methods must mean the best products.

Factory at Flint, Mich.

# WESTON MOTT CO.

# VORTEX

## APORIZER

**"A NATURAL CARBURETOR"**

Information furnished on application  
EASTERN DISTRIBUTOR: C. S. GIBSON  
51 W. 63d St., Cor. Broadway, New York City  
**Reichenbach Laboratories Co.**  
2420 Michigan Ave. CHICAGO

# THE GIBNEY

## ELECTRICK VULCANIZER

Complete with repair kit \$15<sup>00</sup>



Write for Our Booklet on Care of Tires.

**JAMES L. GIBNEY & BRO.**  
215 N. Broad St., Philadelphia, Pa. - 248-52 W. 54th St., N.Y.C.

Please mention The Automobile when writing to Advertisers

# The Searchlight Gas Co.

1121 South Michigan Avenue  
CHICAGO, ILL.

Still in business and growing every day. More and more an *inspiration*. Watch us grow.

### Branches and Refilling Stations

Chicago, Ill.	Atlanta, Ga.	San Antonio, Tex.
Warren, Ohio.	Los Angeles, Cal.	Camden, N. J.
Philadelphia, Pa.	Kansas City, Mo.	San Francisco, Cal.
Detroit, Mich.	Boston, Mass.	
Buffalo, N. Y.	Dallas, Texas	

# Heinze Ignition

MAGNETOS  
TIMERS  
COILS  
SPARK PLUGS

CATALOGUE A SENT ON REQUEST

**Heinze Electric Company**  
LOWELL, MASS.

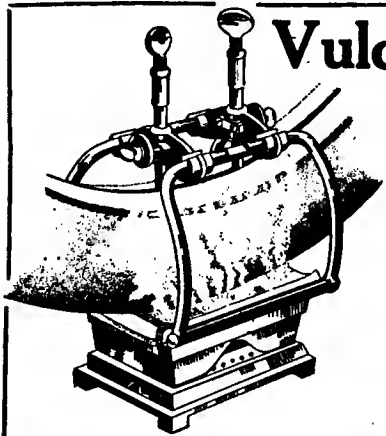

## Vulcar \$12.50

A New Process for repairing tires and tubes. The only portable vulcanizer which moistens rubber while being vulcanized. The only safe vulcanizer for the novice. Any boy can operate it. Send for free book.

**The New Process  
Vulcanizer**

3232 Monroe St., Toledo, O.



# AJAX TIRES

"Guaranteed 5000 Miles"

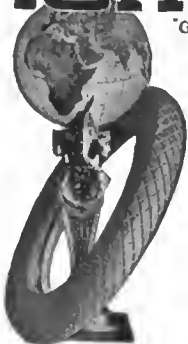

## The Best Touring Tires in the World

The equipment on the four Trophy  
Winning Cars in the  
GLIDDEN TOUR

**AJAX-GRIEB RUBBER COMPANY**

Factories: TRENTON, N. J. General Offices: 1796 B'way, NEW YORK  
Branches in Principal Cities

## The Light That Always Shines



Electric light equipment for automobiles that is one-third more efficient for one-third less money than any other lighting system.

**The Electric Auto-Lite Co.** 135 Michigan St. Toledo, Ohio

# Diamond Tires

We could build them cheaper  
*But We Won't.*

We would build them better  
*But We Can't.*

**The Diamond Rubber Co.**  
Akron, Ohio

**Diehl**  
TRADE MARK

ELECTRIC TESTING  
DYNAMOMETERS

USED FOR  
COMBUSTION TEST  
TRANSMISSION  
CONNECTING ROD  
MOTION TESTS

WRITE FOR  
LATEST BULLETINS  
HAVE OUR ENGINEER CALL

AUTOMOBILE CLUB OF AMERICA

**DIEHL MANUFACTURING CO.**  
ELIZABETHPORT, NEW JERSEY



**All Who Can Afford It Use The**  
**WARNER**  
**AUTO-METER**  
 The "Aristocrat of Speed Indicators"

THE man who takes pride in his car is the one who appreciates the Warner most. He would never disgrace it with anything cheap, inferior and unreliable.

**Warner Instrument Co.,** 1218 Wheeler Avenue  
 Beloit, Wis.

Branches at  
 Atlanta Chicago Denver Kansas City Philadelphia San Francisco  
 Boston Cincinnati Detroit Los Angeles Pittsburgh Seattle  
 Buffalo Cleveland Indianapolis New York Portland, Ore. St. Louis  
 Canadian Branch—559 Yonge St., Toronto, Ont.

**DIETZ**  
**LAMPS**  
 GAS—ELECTRIC—OIL  
 Pleasure and Business Car Types  
 Modern Designs Durable Build

**R.E. DIETZ COMPANY**  
 60 LAIGHT STREET NEW YORK CITY  
 ESTABLISHED 1840



**The CASGRAIN SPEEDOMETER**

SOLD ON A POSITIVE GUARANTEE PROTECTING the buyer at every possible angle, and we back our faith and experience in this matter by offering to put one on YOUR car.

**ON THIRTY DAYS' FREE TRIAL**  
 Write to-day for full particulars.

**CASGRAIN SPEEDOMETER**  
 NEW YORK, 1919 Broadway  
 BOSTON, MASS., 162-172 Columbus Ave.  
 BUFFALO, N. Y., 37 to 39 Court Street

Type C

NO MORE SOOT IN YOUR SPARK PLUGS IF YOU USE



**ALL-IN-ONE**

JUST OPEN THE STOP-COCK AND OUT GOES THE SOOT

ALL-IN-ONE SPARK PLUGS have numerous other advantages. You can stop any knocking in your motor by priming here with a few drops of kerosene. You can instantly find any missing cylinder by turning the pet cock. You can instantly prime your motor. All of these advantages are contained in ALL-IN-ONE SPARK PLUGS, and they cost no more than the other kind.

**\$1.50 EACH**

**FRONTIER SPECIALTY CO**  
 720 Main Street, Buffalo, N. Y.

**ASK FOR THE FAMOUS**



*Mea*

**MAGNETO**

Our Guarantee  
 A MEA makes cranking easy and safe with spark fully retarded and also increases power and flexibility of motor.

**MARBURG BROTHERS**  
 1777 Broadway  
 NEW YORK  
 Tel. 3993 Columbus



**STA-RITE**  
 "STAYS RIGHT THE LONGEST"

PERPETUALLY GUARANTEED

We agree to place in as good working order as when new any STA-RITE Ignition Plug AT ANY TIME when returned prepaid to our factory. Just send the old one with 5c. postage for return.

POSSIBLE ONLY WITH STA-RITES. RESULT OF TEN YEARS' EXPERIENCE.

The patented double porcelain positively prevents cracking. The outer cap completely protects the inner heated part.

Cheapest for Owners—Least Trouble for Drivers—Best Sellers for Dealers.

Price of any style STA-RITE Plug, \$1.00. We Make STA-RITES for any style engine. Mention the engine and we'll send you a plug adapted for it.

THE R. E. HARDY CO. (Inc. 1900), 1134 Austin Ave., cor. May St., Chicago, Ill.

**We Are the Largest Manufacturers in the United States, of**  
**WOOD BOXES**  
 FOR HOUSING COILS AND MAGNETOS

Thoroughly kiln-dried Oak, Mahogany, Circassian Walnut, Black Walnut and Birch Lumber always on hand. Will gladly quote from samples or Blue Prints without obligation to you. We are ready to close contracts, large or small, guaranteeing material, workmanship and deliveries, all kinds of Special Cabinet Work on contract.

**THE WABASH CABINET CO.**  
 WOODWORK MANUFACTURERS WABASH, IND.

*Woodworth*



WOODWORTH TREADS are the only true tire protectors. They never chafe or heat the tires. They are held in place by coil springs along the sides, which automatically take up all slack and prevent any looseness. The protector is always tight and smooth. No other protector can be fitted in the way that these automatically fit themselves.

They fit all makes of tires—anyone can easily put them on. Send for Catalogue.

Leather Tire Goods Co., Niagara Falls, N.Y.  
 Canadian trade supplied from Niagara Falls, Ont.

Please mention The Automobile when writing to Advertisers

**ELEKTRA**  
ASBESTOS FRICTION

**For BRAKES and CLUTCHES**

Over 1,000,000 feet of material produced by our PATENTED PROCESS in daily use.

High coefficient of friction gives greatest factor of safety in operation of all brakes and clutches and OUR PATENTED PROCESS produces the only HIGH-FRICTION facing. THIS MATERIAL gives better satisfaction and wears longer than any other facing and is especially adapted for manufacturer's use; our BAND linings, as well as RINGS and CONES for CLUTCHES being formed ACCURATELY to shape and size.

**F. L. Horton Manufacturing Co.**  
 36 Whittier St., Boston, Mass.



**SHELDON AXLES SPRINGS**

**THE SHELDON AXLE CO.**  
 WILKES-BARRE, PA.

CHICAGO OFFICE: 66 East 12th Street  
 DETROIT OFFICE: 1215 Woodward Ave.

**COVERT**

**TRANSMISSIONS**

are the very best for hard, exacting service.

Our construction has been approved by leading engineers. Every gear is of nickel steel, carbonized and heat treated.

Covert Transmissions will remove all doubt about the efficiency of that part of your car

**COVERT MOTOR VEHICLE COMPANY**

Sales Office: Ford Building, Detroit, Mich.  
 Factory: Lockport, N. Y.



The superiority of

**SCHAFFER BALL BEARINGS**

is conclusively proven by the fact that they are used in the leading cars throughout the world.

**BARTHEL, DALY & MILLER**  
 42 Broadway, New York City.



**JONES RECORDER**

Gives time, speed and distance. Number of stops—length of each stop. Complete record of every movement or stop of vehicle marked on chart. Absolutely essential to all operators of motor trucks or delivery wagons.

The Jones Recorder consists of a strong brass casing, containing a clock work and flexible shaft from the drive wheel of the vehicle.

**The Jones Recorder**  
 Broadway and 76th Street, New York

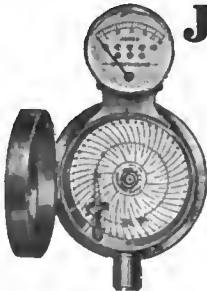

**Stewart** GAS SAVER

**GAS SAVER**

(An Auxiliary Air Device)

Saves up to 40 per Cent in Gasoline

SEND FOR LITERATURE

Manufactured by  
**Alfred C. Stewart Machine Wks.** 1008 Santos St. Los Angeles, Cal.

STEERING COLUMN CONTROL



**ELECTRIC SIRENO HORN**

REG. U. S. PAT. OFFICE

**SIRENO**

PATENTED

A Motor Car Without a Long Range Warning Signal is Like a Railroad Locomotive Without a Whistle

The SIRENO is a Long Range Warning Signal—the "Mile-Ahead Horn."

Its peculiar piercing note of wonderful penetrating power always demands the right of way.

The SIRENO is electric—that means instant response at the will of the driver—it never fails. It is operated by any battery—dry or storage

The SIRENO is manufactured in several styles and sizes, and we would suggest that you write for additional information.

**The SIRENO Company** 1600 Taylor Bldg. New York City



**TIRES THAT NEVER TIRE**

The auto-ist's dream realized at last: "Tires That Never Tire." With your car equipped with this wonderful device, you can forget all about tire trouble and enjoy motoring as you never did before. No need for extra tires. No delays with tire trouble. Tire expense reduced to the minimum. Cost Nominal. Service Phenomenal. Agencies are being established in all cities and towns. Good territory still open. Write us at once.

**UNIVERSAL TIRE PROTECTOR CO.**  
 Lock Box 678 A Angola, Indiana, U. S. A.

Please mention The Automobile when writing to Advertisers

**TIRE TROUBLES**  
 have no terrors for users of  
**AUTO INNER CASINGS**  
 Reduce mileage cost 50%

We publish a valuable little booklet  
 "The Care and Wear of Tires"  
 which we will send FREE on request.  
 Write today and learn something about tires.

**Western Automobile Supply Co.**  
 3900 Sheridan Road Chicago, Illinois

The Indisputable **EFFICIENCY, ACCURACY** and  
**SILENCE** of

**WARNER TRANSMISSION**  
**DIFFERENTIAL** and  
**STEERING GEARS**

are sufficient evidence of the  
**SUPERIOR METHODS** and **FACILITIES** for  
 producing a **HIGHLY REFINED PRODUCT**.

**WARNER GEAR CO.**  
 MUNCIE, IND.

**GYREX**  
 THE MIXER

**Price, \$3.00**  
 Saves 10% to 25%

gasolene. Fits intake  
 pipe. Spins around at  
 great speed and "mixes  
 the mixture." We send  
 it to you on trial.

If not satisfactory your  
 money is cheerfully re-  
 funded.



**THE ROYAL EQUIPMENT COMPANY**  
 420 Housatonic Avenue BRIDGEPORT, CONN.

Here's a  
**Carbon Remover**

Which will thoroughly  
 clean a cylinder—top,  
 sides and piston head—in  
 two minutes.

Avoid the time and expense  
 consumed in tearing down the  
 motor with the incidental dis-  
 turbing of the adjustments—stop  
 scratching and nicking the metals  
 with sharp edged tools, stop in-  
 candescence on the cylinder head,  
 smoke and engine deterioration—  
 get at least one of these devices and use it occasionally in keeping your  
 engine free from carbon, the greatest foe to the life, power and speed of  
 engine. Don't let the carbon accumulate and don't get the "remover" that  
 is a "cure" worse than the disease. Order from your dealer "the little soft  
 chain" but if he cannot supply you, we will send it postpaid by return mail.  
 PRICE 75¢. Three for \$2. (You can clean two cylinders at the same  
 time with two chains.)

Made of tough soft wire (90% copper) with no edges or angles and cannot  
 cut or scratch.  
 Always state kind of motor when ordering.

**E. S. MICHENER, East Washington Street, NEW CASTLE, PA.**



**Bower Roller Bearing Company**  
 DETROIT, MICHIGAN

Manufacturers of

**HIGH GRADE ROLLER BEARINGS**  
 FOR ALL PURPOSES

Our Consulting Engineering Depart-  
 ment is always at your service.

Send for catalog, price-list and speci-  
 fication sheets of sizes



**IDEAL SHOCK ABSORBERS**

Positively the best Absorbers on the  
 market—bar none.

Absorb the shocks.  
 Prevent bumping the springs.  
 Uphrow positively stopped.  
 Adaptable to any car.  
 Easily attached.  
 Last forever.

Prices Full Set Rear Only	
For cars under 1500	\$18.00
For cars 1500 to 2800	\$24.00
For cars 2800 to 3600	\$30.00
For cars over 3500	\$40.00

Sold on positive guarantee of  
 satisfaction or money back.

Special on Ford Model T. Representatives wanted in unoccupied territory.  
 For sale by garages and dealers or directly by

**AMERICAN SALES CO. (Exclusive Agents) 1880 Mt. Elliott Ave., Detroit, Mich.**



REG. U. S. PAT. OFF.

**FLEXIBLE COMPOUND**

TRADE MARK

**MR. MANUFACTURER**

You have trouble in hold-  
 ing paint on your steel, wro  
 and woodwork and in pre-  
 venting chalking, fading and  
 loss of gloss, and never have  
 had the service from your  
 paint that the expense would

lead you to expect. As a baking material, it is perfect.

**FLEXIBLE COMPOUND is**  
 Rust Proof {Absolutely} Weather Proof  
 Water Proof Flexible  
 Acid Proof Perfect

The above statements are TRUE and we CAN PROVE THEM.

If interested our representative will call and make a practical demonstration.

**JOS. M. BROWN & CO., Distributors**  
 Great Northern Building CHICAGO, ILL.

**Long Radiators**

THE LATEST DEVELOPMENT  
 IN  
**High Grade Radlators**

THE LONG MANUFACTURING CO.  
 Detroit, Mich.



Please mention The Automobile when writing to Advertisers

**Warren**  
**MOTOR CARS**

A snappy, progressive line that shows red blood and live ideas. Compare and you will see why the Warren wins.

**"12-30" Roadster - - \$1175**  
**"12-30" Demi-Tonneau - 1250**

Including Top and Automatic Windshield. Self-Starter, \$50 extra.

"12-30-K" Touring Car - \$1300 - "12-35" Roadster - \$1415  
 "12-35" Touring Car - \$1500 - "12-40" Touring Car - \$1700  
 Including Self-Starter, Automatic Windshield, Silk Mohair Top, e.c.

Warren Motor Car Co. 391 Holden Ave., Detroit, Mich.

**WINTON SIX**

**Consider Changing Conditions**

There is more reason for buying cautiously right now than ever before in automobile history. "Consider Changing Conditions" gives the inside facts.

*Shall we send you a copy?*

**The Winton Motor Car. Co.**  
 422 Berea Road Cleveland, O.

**ALUMALOYD**

**RUST-PROOF SHEETS**

Make possible the all-metal car. Light in weight with the strength of steel. The ideal material for bodies and all sheet metal parts. Takes a high finish with little labor. Get full details.

**The Alumatoyd Products Co.**  
 Canton, Ohio

**R-C-H "Twenty-Five"**

**5-Passenger Touring Car**  
**\$850 Fully Equipped F.O.B. Detroit**

All and more than you'd expect in an \$1800 car. See it for yourself.

Write for folders. Dealers better wire.

**R. C. HUPP, Manufacturer**  
 Distinct from and having no connection with the Hupp Motor Car Company  
 100 Lycaste St. DETROIT, MICHIGAN

**KISSELKAR**

Kissel Kars maintain the reputation as the conspicuous automobile values in America today—Six cyl., 60 H.P., \$3,000—fully equipped; Four cyl., 50 H.P., \$2,350; 40 H.P., \$1,850; 30 H.P., \$1,500. Write for free portfolio.

Kissel Motor Car Co. 122 Kissel Ave., Hartford, Wis. Branches and agencies everywhere



Every inch a car

**McFARLAN**

**Six Cylinder, Self Starting**  
**2 Models. Fully Equipped.**

40 — 45 H. P. \$2,100.00  
 55 — 60 H. P. \$2,750.00

Ask for full information. Territory open for live dealers'

**McFarlan Motor Car Co., Connersville, Ind.**

No Need to Buy New Tires THIS Fall  
 Make your old ones last the season by using **THE INTERLOCK INNER TIRE**

The HEAVIEST, STRONGEST and BEST reinforcement made—contains largest number of plys. Prevents PUNCTURES, BLOW-OUTS, tube PINCHES. Strengthens the WHOLE tire, especially good to reinforce casings that are rim-cut or weak along sides. Double-Fabrics have 5 years successful record—thousands in use, giving splendid satisfaction to owners.

The Interlock Inner Tire has MADE GOOD. We want Live Dealers and Agents to handle it in cities and districts. Our proposition is RIGHT—write for it to-day. Booklet and sample section free to owners giving name of Supply Dealer.

**DOUBLE-FABRIC TIRE CO.**  
 108 E. 7th St., AUBURN, IND.



**WILCOX TRUX**

Are built so the driver's cab can be entirely closed in cold weather. This allows the driver and truck to work regularly, regardless of weather.

The less you know about trucks, the more you need a good truck. The more you know, the more you'll appreciate Wilcox Trux. Ask for catalog.

**H. E. WILCOX MOTOR CAR CO.**  
 1042 Marshall St., N. E. Minneapolis, Minnesota

Please mention The Automobile when writing to Advertisers

**If there is no Pullman agency in your territory  
Let Us Hear From You At Once**

Our 1912 line includes the famous Pullman "4-30," "4-35," "4-50" and our two big leaders, the "4-40" and "6-60." The equipment on the last three models includes self-cranking motor, electric lighting device, top, windshield, speedometer, foot and robe rails, etc.

Pullman cars "lead the leaders." Some of our agents sell as many as 200 Pullman automobiles each year. Let us put you in touch with our agents and find out for yourself why Pullman agents are always good agents.

"OUR OFFER." If there is no Pullman agency in your territory we will arrange to "show you" at absolutely no expense to you.

**PULLMAN MOTOR CAR CO. 238 N. GEORGE ST. YORK, PA.**

**BRODESSER MOTOR TRUCKS**

**Built for Service**

have made good throughout the five years past and our first trucks are still running

CAPACITY 1 TO 3 1/2 TONS

**Brodesser Motor Truck Company**

SALES DEPARTMENT

Harvester Building Michigan Ave., Chicago, Ill.

AGENTS: We will offer desirable selling connections to a few energetic, reliable agents.

At  
Madison  
Square  
Garden



**Back of Every Corbin Car**

stands an organization with fifty years of successful manufacturing and commercial experience, ample capital, a thoroughly equipped and up-to-date plant, and the determination to keep every customer satisfied.

Model "40" at \$3,000 Model "30" at \$2,000

Complete description of 1912 models in Catalogue E. Write for it.

**Corbin Motor Vehicle Corporation  
NEW BRITAIN, CONN.**

**Franklin "Little Six"  
30 HORSE POWER \$3500**

Six cylinders in a small car—  
that is the story

A small six-cylinder car. Beautiful in design and proportion. Franklin quality throughout.

A five-passenger car. Fully equipped.

FRANKLIN AUTOMOBILE COMPANY Syracuse N Y

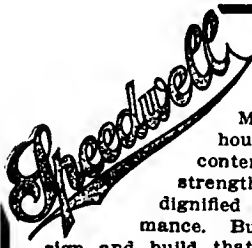

**\$2500 to \$2900**

More than this car offers cannot be bought. It concedes nothing to its costliest contemporary in structural soundness and strength, in luxury, in ease and comfort, in dignified appearance, or in satisfactory performance. But brings you notable features of design and build that are peculiar to itself.

**Speedwell Motor Car Company**

10 Essex Avenue  
Dayton, Ohio



Model 12-H—\$2500.  
Standard chassis of all Speedwell models has 123-inch wheel base and 50 H.P. motor.



Cost Less per  
Horsepower  
and per  
Wheel Base

Furthermore, they excel equally in the general excellence of design, workmanship and finish. They are the equal, and in many points the superior, of most cars selling for \$3,000 or \$4,000. Send for our Table of Comparative Motor Car Values. It will make you a posted purchaser.

CLARKE-CARTER  
AUTOMOBILE  
COMPANY  
JACKSON, MICH.

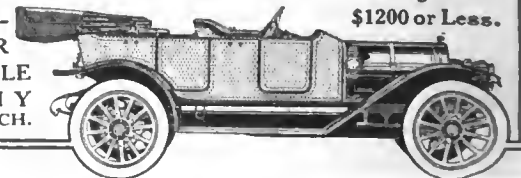

Inch than  
Any Other  
Automobile  
Selling for  
\$1200 or Less.



THE ULTIMATE CAR  
(KNIGHT TYPE MOTOR.)

The first American Car to adopt the Silent Knight Motor—the Engine used by Daimler Mercedes, Panhard and Minerva

**THE F. B. STEARNS CO.  
CLEVELAND, OHIO**

Branches: New York, Pittsburg, Atlanta, Minneapolis and San Francisco



**THE UNION "25" \$650**

"Made a Little Better Than Seems Possible"

25 H.P., 4-cylinder motor, Bosch magneto, Schebler carburetor, Wheelbase, 100 inches. Equipment regular, includes 3 oil lamps, tools, pump, jack, tire repair kit and horn. We furnish top windshield, trunk, gas lamp and generator for \$50.00 extra. Write for Literature.

UNION SALES CO., 61 E. Spring St., Columbus, Ohio





### AMPLEX VALVELESS SELF-CRANKING MOTOR

No Valves No Sliding Sleeves

The Amplex valveless motor receives its gas, explodes its gas, discharges its gas and delivers its power with one upward stroke and one downward stroke only. Each power stroke is completed after two movements only of the piston.

Write for AMPLEX EDUCATION, which fully illustrates and describes the entire construction.

**Simplex Motor Car Co.**

Mishawaka, Indiana

### E-M-F "30" FLANDERS "20"

The cars that have made the high price automobile a fad

**E. M. F. CO., Automobile Manufacturers**  
DETROIT, MICH.

**1912**

The highest grade car on the market regardless of price.

**KLINE  
KAR**

\$1750 \$2250  
\$2850 \$3600

**1912**

Complete specifications and catalogue upon request.

Kline Motor Car Corporation  
RICHMOND, Va. YORK, Pa.



### Motor Cars New England's Best Product

Built in three chassis models with top different body designs.  
*Advance information sent on request.*

**AUTOMOBILE CO.**  
Springfield, Mass.



## Ohio

YOU might be able to pile onto a car more extravagance, but you can't pile into it more all-around efficiency than found in the 40 horse-power Ohio. By "all-around efficiency" is meant ability to meet all the requirements ever exacted of an automobile and to meet them just a little better than expected of highest priced cars. A glance at the specifications and then at the price will convince you that the Ohio offers its owner greater motor value than ever before obtainable.

A Little Territory Still Open for Aggressive Agents. Send for Catalog No. 52.

**\$2,150** Ohio Motor Car Company **\$3,350**  
Elmwood Station - Cincinnati, Ohio

### Motor Car Manufacturers Since 1893

# HAYNES

1912

Occupying the newest and most modern automobile manufacturing plant in America.  
**HAYNES AUTOMOBILE COMPANY**  
Dept. T-7 KOKOMO, IND.



## Cartercar

—a thousand speeds—one lever control—will climb a 50% grade. Pleasure cars and light delivery vehicles.  
*Write for facts.*

**Cartercar Company, Pontiac, Michigan**



UNIT POWER PLANTS  
KEEP OIL IN AND DIRT OUT

Model 52 -	\$1800
Model 42 -	\$1500
Model 32 -	\$1100
Model 26 -	\$1100
Model 28 -	\$1000

1912 MODELS NOW READY

**Jackson Automobile Company**  
1208 East Main St.  
JACKSON, MICH.



Please mention The Automobile when writing to Advertisers

The Borland Electric Brougham, the car that heads the list of Chicago Electric Car sales will be on display at the Coliseum, Chicago, during the National Association of Automobile Manufacturers Exhibition, January 27th to February 3d, 1912. A connection is desired with a few successful agents who will appreciate what we have to offer in the way of quality, price, service and the best selling plans in the business.

THE BORLAND-GRANNIS CO.,  
2634 Michigan Avenue Chicago

# SCHACHT

For four years our "3 IN 1" cars have been the most satisfactory and popular low-priced cars on the market. Their easy convertibility from runabout to touring car or delivery wagon gives them a unique advantage over any other car in their class. They offer you the best chance to cover this wide and profitable field. Write today for Catalogue.

THE SCHACHT MOTOR CAR CO. 2821 Spring Grove Ave. CINCINNATI, OHIO

THREE  
CARS  
IN  
ONE

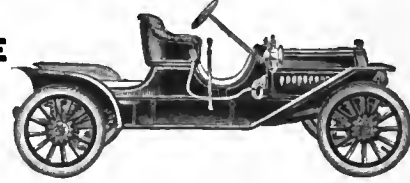

8 00  
\$5 0

## CROW "ELK-HART"

The cars that were built to set a new high-water mark in Automobile values.

12 models for 1912.

CROW MOTOR CAR CO.  
ELKHART INDIANA



THE AUTOMOBILE CATECHISM (Revised Edition). The One Best Book for Car Owners. The demand for this most comprehensive work has encouraged its publishers to produce in this edition a work filled with terse, plain information, covering every possible question which may arise in your automobiling experience. Its scope has been broadened, its size has been more than doubled, its fund of information has been enlarged. Briefly—The Automobile Catechism treats of the automobile in modern form and of all of its troubles that may be remedied by the driver. It asks the question—then answers it. Size, 5 inches by 7½ inches (convenient pocket size). 264 pages (gold edged). Flexible and handsome morocco binding (gold letters). Price, \$2.50, prepaid. Send your order to-day. We will ship the day order is received. THE AUTOMOBILE, 231-241 W. 39th St., New York.

The Pioneer Moderate Priced Six-Cylinder Car

Havers Self-Starting "Six-44"



Price \$1850

The Havers Motor is of the Six-Cylinder, 4-cycle long-stroke type; 44 H. P.; Bosch Magneto; dual system; Model "C" Stromberg Carburetor. 122-inch wheelbase, 36x4-inch wheels; Presto starter. Springs, semi-elliptic front, platform suspension, rear; rear axle, full floating type.

Full specifications sent on request.

Havers Motor Car Co., 2770 28th St., Port Huron, Mich.

# STAVER CHICAGO

Every dealer who has taken up the new Staver Dealers' proposition for 1912, is enthusiastic about it. If you haven't heard it, write us today.



STAVER CARRIAGE CO.  
76th and Wallace Streets, Chicago, Illinois

30 H P Model L \$1250

40 H P Model H \$1750

# Colby CARS

SELF STARTING!

EXTRA MODEL L 1912 STANDARD MODEL H

COLBY MOTOR CO.  
MASON CITY, IOWA.

## THE SELDEN CAR

ONE CHASSIS—FIVE BODY STYLES

Range of prices from \$2500 to \$3750  
Full floating rear axle—multiple disc clutch—electric lights on all cars.

Extra large valves and wonderfully efficient lubrication system.

Selden Motor Vehicle Co., Rochester, N. Y.

**\$1750** *Great Western* **\$1750**

**FORTY**

**A Leader for Comfort and Power**

This 1912 detachable fore-door model is a handsome—powerful—economical car. Handbuffed leather upholstery—beautifully painted and completely outfitted with superb appointments. Write for catalogue.

**GREAT WESTERN AUTOMOBILE CO.**  
PERU, IND.

**CHASE MOTOR VEHICLES**

Selected by the Big Ones Who Know

**Q** Because their simplicity, durability, economy and efficiency have been thoroughly demonstrated.

Because their mechanical excellence appeals to men who KNOW HOW a motor wagon should be built.

Their use means a better delivery service at a much less cost. Send for facts and real figures of operating costs. Catalogue FREE.

**CHASE MOTOR TRUCK CO** 90 Wyoming St., Syracuse, N. Y.

**SELF-PROPELLED VEHICLES.** By J. E. Homans. An excellent book treating of the practical side of the construction and operation of automobiles, with full information for the novice or the experienced operator. Tells what to do and how to do it. Describes in detail the mechanism of a modern car and explains the functions of each part. Forty-four chapters of good sound information for those interested in automobiles. This book contains 672 pages and over 500 interesting illustrations and diagrams. Size, 5 1/2 inches by 8 1/2 inches. Printed on fine paper and substantially bound in cloth. Delivered, \$2. Address THE AUTOMOBILE, 231-241 W. 39th St., New York.

**The Decatur Hoosier Limited**

**1-1 1/2 TON TRUCK**

This truck, which is in the service of the Henry Siegel Co. of Boston, Mass. has travelled six thousand miles on the original set of pneumatic tires, without repairs or expense of any kind to the truck.

The purchase of a second truck by the Henry Siegel Co. proves that the service received from the Decatur Hoosier Limited Truck has been absolutely satisfactory. We are doing the same thing for other concerns in twenty different lines of business. We can do the same for you. Write for particulars and catalog.

**Decatur Motor Car Co.**  
Manufacturers  
Decatur Indiana

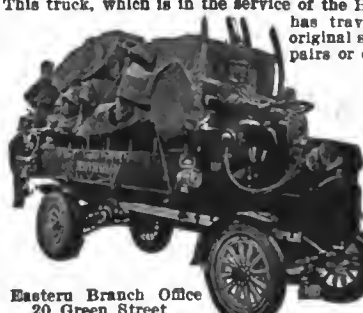

Easteru Branch Office  
20 Green Street  
Cambridge, Mass.



*"Quality of a Master"*

**LENOX CAR**

The best that money can buy  
\$1800—Fully Equipped

AGENTS WHO KNOW WANTED IN OPEN TERRITORY

Lenox Motor Car Co., Boston, Mass. { 3368 Washington St  
16 Columbus Ave.

**The Sturdy Stutz**

The Car That Made Good in a Day—  
Now Makes Good Every Day

Complete motor car service is assured in every Sturdy Stutz Car. The Stutz record in racing is one of consistency, showing that the car has been properly designed—and carefully manufactured. Send for catalogue A1, showing models we manufacture.

Some productive territory open to dealers.

 **Ideal Motor Car Company**  
Manufacturers of Stutz Cars  
Indianapolis, Indiana

Stutz cars will be exhibited at Grand Central Palace Show, New York and at the Chicago Show.

**TRUCKS AND DELIVERIES**

BEST AND CHEAPEST  
ALL SIZES AND FOR  
ALL PURPOSES

AGENTS  
DESIRED



JOHNSON SERVICE CO.  
MILWAUKEE, WIS.

*Lexington* \$1775



Rutenber Motor, Bosch Magneto and 4 Coil 5 Spark Plugs, beats any dual system; Self Starter, Warner Mfg. Co. Transmission, Timken Axles, 113" Wheel Base, 4x34 Goodrich—Goodyear—Diamond Tires, Finest Upholstery, Springs Half Front—Three-quarter Rear, Five-Passenger Car. A better car can't be found at this price.

Write for catalog.

**LEXINGTON MOTOR CAR COMPANY, CONNERSVILLE, IND.**

Please mention The Automobile when writing to Advertisers

**CLARK 30** Open Touring Car \$1050  
Torpedo Roadster \$1050  
Fore Door \$1100  
114 inch wheel base—32 x 3 1-2 Tires

**CLARK 40** Open Touring Car \$1250  
Torpedo Roadster \$1250  
Fore Door \$1300  
116 inch wheel base—34 x 3 1-2 Demountable Rims  
Enclosed Valves. Rutenber Motor 4½ x 5½  
No Deposits Liberal Contract

**CLARK MOTOR CAR COMPANY**  
Shelbyville Indiana



**K-R-I-T**  
Five Passenger  
Touring Car  
Fully Equipped  
\$800.00

**Foredoor Runabout, \$800.00**  
**Roadster, \$825.00**

Agents: Some good territory unassigned  
Write at once for proposition

**K-R-I-T MOTOR CAR COMPANY**  
Department A, DETROIT

**INTERNATIONAL CHAMPION**  
**THE MARMON**  
The Easiest Riding Car in the World



Winner of many of the world's greatest victories including the International Sweepstakes Race, covering 500 miles in 402 1-7 minutes at the record-breaking speed of 74.68 miles per hour.  
Now when the best car in the world can be bought for \$2750 don't you owe it to yourself to buy it if you are going to invest enough money to buy any really good car?

**NORDYKE & MARMON CO.**  
Indianapolis Established 1851 Indiana  
Sixty Years of Successful Manufacturing

*This car has a More Powerful Motor and a Bigger Wheel Base for the money than any other car.*

**1912 New Parry \$1450**

Built to make every New Parry Owner a New Parry Enthusiast.

Dealers—write for our selling plan.

**THE MOTOR CAR MFG. CO.**  
INDIANAPOLIS, IND., U.S.A.

**Marathon**

Not Simply a Car  
But Car Service

¶ A good car painstakingly built from carefully tested materials. Literature and detailed information on request.

**MARATHON MOTOR WORKS** Nashville, Tenn.  
12TH AVENUE, N. & N. C. & ST. L. RY.  
General Offices, 1204 Clinton St.

**METZ "TWENTY-TWO" WATER COOLED**



**\$495**

**1912 Model Completely Equipped as shown**

Four cylinder motor, twenty-two HP, valves and all moving parts enclosed and dust-proof. Chains enclosed in cases running in oil. High tension magneto ignition. 10,000 miles on set of tires. Ask for Book "J" with hill climbing guarantee. Good dealers wanted in unoccupied territory.

**METZ COMPANY, WALTHAM, MASS.**

**COLE**

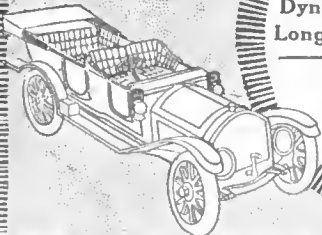

Five Passenger Touring Car, Self-Starter;  
Ward Leonard Electric Dynamo Lighting System;  
Long Stroke Motor, 4½ x 5½.  
Price \$1885.

**Henderson Motor Sales Co.**  
Indianapolis, Ind.



**Made in 3 Ton**  
**1½ Ton Sizes**

**Universal Motor Trucks**  
"Built for Business by Business Men"  
SEND FOR OUR LITERATURE

**UNIVERSAL MOTOR TRUCK CO.**  
502 Theodore St., Detroit, Mich.

Please mention The Automobile when writing to Advertisers



**Herreshoff**  
"The Little Thoroughbred"

Touring Car, \$1150  
Colonial Coupe, 1400  
Roadster, 950

The graceful lines of the Herreshoff—the simplicity of its motor and axles—the elimination of needless weight without sacrificing any of its strength—the low cost of up-keep—these points appeal equally to the expert and to the novice in the art of automobiling.

Write us for new catalog.

**The HERRESHOFF MOTOR CO.**  
Detroit, Michigan



Roadster—\$950.

**Farthest on a Single Charge**

**Baker Electric**

SHAFT DRIVEN

because the Baker chassis is designed by engineers—scientifically—for the purposes of an electrical-propelled vehicle—and for no other, saving utmost power.

Write for dealer's proposition

**The Baker Motor-Vehicle Company**  
29 West 80th Street, Cleveland, Ohio

**McINTYRE—1912**

Cup Winner—Perfect Road score—Perfect Technical Score, in First Annual Commercial Car Contest by Chicago Motor Club, September, 1911

**Pleasure Cars Commercial Cars**

4 cyl. 35 H.P. 5 pass. \$ 1800	2 cyl. 14 H.P. 600 lb. cap. \$ 650
4 " 40 " " 1250	2 " 20 " " 1800
4 " 45 " " 1650	2 " 24 " " 2000
	4 " 35 " " 3000
	4 " 40 " " 4000
	4 " 40 " " 6000
	950 Chassis
	1350 "
	1600 "
	2350 "
	2850 "

Builders of vehicles for forty years

We want a few more good agents. We arrange local advertising for you We sell to dealers only.

**W. H. McINTYRE CO., Auburn, Indian**

**THE ULTIMATE CAR**

**THE LAMBERT**

Patented Friction Drive Automobiles

Five Exceptional Models 1912



Five Exceptional Prices 1912

**THE BUCKEYE MANUFACTURING CO., Anderson, Ind., U.S.A.**



**Moline**  
"King of the Road"

**The Aristocrat of American Roadsters**

This handsome, roomy, foredoor, straight line car with big artillery wheels and tires, has every desired refinement. In addition it is equipped with the famous

**4x6 Long Stroke Motor**

unequaled in efficiency, silence of operation and durability. While rated at 35 H. P. this motor will actually develop almost 40. The Roadster shown here is only one of the four New Models of the "Dreadnought" Moline "35." Write for Folder No. 39 showing all styles, specifications and prices.



Dealers will find our latest proposition specially interesting

**Moline Automobile Company (11)**  
39 Keokuk Street EAST MOLINE, ILLINOIS

**"THE CAR AHEAD"**

**1912—Pilot 40—1912**



The car with the wonderful motor

36 x 4 tires, 120" wheel base.  
List, \$1,650.00.  
Top, Windshield and Speedometer, \$100.00 (net) extra.

**Pilot Motor Car Co., Richmond, Indiana**

**Halladay**

**\$1100 TO \$2750 NINE DIFFERENT MODELS**

**EXAMINE HALLADAY CARS**  
They will stand comparison with cars of any price.  
Write for our Agency Proposition.  
You'll like our way of doing business.

**STREATOR MOTOR CAR CO., Streator, Illinois**

Please mention The Automobile when writing to Advertisers



### Dispel Ignition Mystery

The ignition on your car will be simple and plain to you if you equip with the

## Remy Magneto

Day after day it performs its work faultlessly—and with a minimum of attention. (One simple outside adjustment)—and a Remy Service Station to do that for you.

See the Remy Magneto Exhibition at either the New York or Chicago shows. They are intended to make magneto ignition intelligible to you. Or, if you'll not attend, send for literature.

### Remy Electric Company



FACTORIES - ANDERSON, INDIANA - GENL. OFFICES  
New York, Boston, Chicago, Kansas City,  
San Francisco, Detroit, Indianapolis, Min-  
neapolis, Denver, Philadelphia, Los Angeles.



## The Lakewood Hotel

LAKWOOD, N. J.

The Hotel that made Lakewood Famous.

### NOW OPEN

Under the Direction of  
Mr. Louis Frenkel, of the Hotel Kaaterskill,  
Kaaterskill, N. Y.

Lakewood is one hour and thirty minutes from New York city, and for its climate, its pine trees and its wonderful dry air it has no equal.

Prospective patrons going to Lakewood will find the Hotel Lakewood one of the best managed hotels in the world.

Special inducements will be made for parties who wish to spend the season at this wonderful resort.

There is also in connection with this hotel one of the finest 18-hole golf courses in America.

The hotel will be conducted on the most exclusive lines on the American plan.

F. H. NUNNS, Manager.

**CUTS  
USED IN THIS  
PUBLICATION  
ARE MADE  
by the  
MOSS  
PHOTO  
ENGRAVING CO.  
PUCK BUILDING  
295-309 LAFAYETTE ST. COR. HOUSTON  
NEW YORK  
TELEPHONE 81 SPRING  
ESTABLISHED 1871**

## Hotel La Salle

Chicago's Finest Hotel

George H. Gazley, Manager La Salle at Madison Street

The central location, excellent service, elegant equipment and furnishings, and home-like atmosphere make Hotel La Salle the most popular hotel in Chicago.

**Rates:**

*One Person.*

Room with detached bath - - - - \$2 to \$3 per day  
Room with private bath - - - - \$3 to \$5 per day

*Two Persons.*

Room with detached bath - - - - \$3 to \$5 per day  
Room with private bath - - - - \$5 to \$8 per day

*Two Connecting Rooms with Bath:*  
Two Persons - \$5 to \$8 per day  
Four Persons - \$8 to \$15 per day

*Suites:*  
\$10 to \$35 per day

**All rooms at \$5.00 or more are the same price for one or two persons**

Please mention The Automobile when writing to Advertisers



Gasolene Should Be Stored

**in a BOWSER STORAGE SYSTEM**

No garage should be without this up-to-date method of preventing loss by evaporation and danger from fire.

We make systems to fit all sizes of garages—large and small.

Pump in garage—tank outside underground—both pump and tank lock.

A meter enables you to keep a continuous record of gasolene used—no shortages.

System eliminates all water and dirt from gasolene.

750,000 already in use.

Let us send you further information.

Ask for book No. 3A.

S. F. Bowser & Co.

(Inc.)

Fort Wayne, Ind.  
New York, Boston,  
Chicago, St. Louis,  
Minneapolis, Phila-  
delphia, Dallas,  
Atlanta, Toronto,  
San Francisco.



The First  
1912 Exhibition of  
**BOSCH**  
Products

Space No. 218  
**Madison Sq. Garden**  
Gallery, West End  
Jan. 6th-20th

MANUFACTURERS and the Trade will find this Bosch Exhibit the most comprehensive display of high class ignition apparatus ever brought to the attention of the public.

Stock Champion

Road Race Champion

# National 40

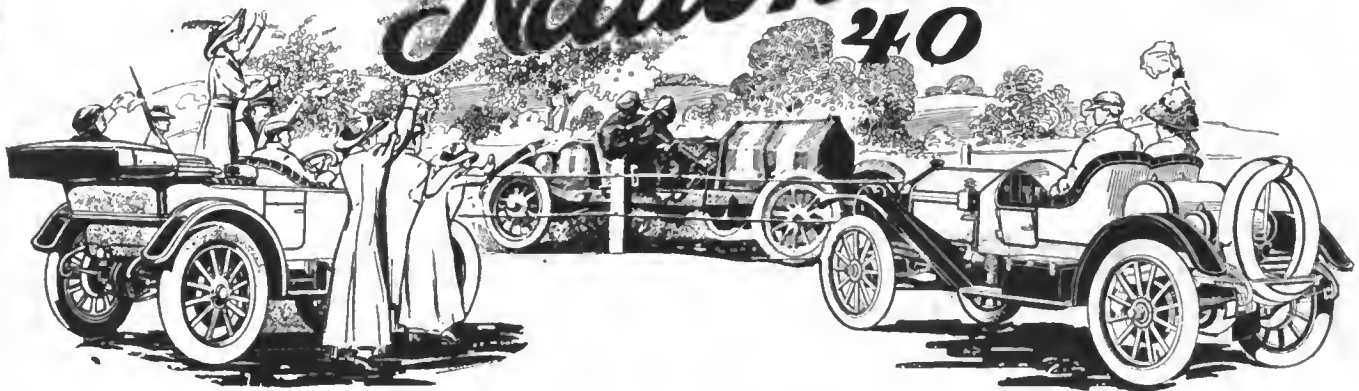

TO select the most successful make of car is a comparatively easy task, for none can question the right of the National to this honor. "The record of the National in 1911 was nothing short of phenomenal."

This is, in part, the tribute paid the National 40 by "Motor Age" in select-

ing the 1911 Road Race Champion. The National, already recognized Stock Champion, did not confine its winnings to any one class of events, but demonstrated superiority of design, workmanship and material in all kinds of contests.

Harvey Herrick is selected Road Race Champion driver because of his

world's record at Santa Monica Free-for-All in a National, with an average of 74.63 miles per hour.

The buying public knows that National cars gracefully met the severe competition of 1911 and comfortably outstripped cars of higher price. Now is the time for dealers to act on this cue and profit by the proven superiority of the National 40.

**National Motor Vehicle Co.,** 1000 East 22d Street **Indianapolis, Ind.**

# THE NEW KAMLEE AUTO TRUNK

is absolutely dust proof

See the new Interlock Edge—It makes the Kamlee air tight

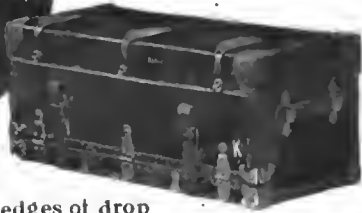

The edges of drop front and top lock together as shown in sectional view at left. A rubber tubing at bottom of groove conforms to any irregularity or give in top and front.

Every Kamlee is fitted with two or more standard sized removable suit cases, which can be removed without taking trunk from rack. Kamlees are made to fit any car.

A waterproof covering is fastened over the top with patent spring-swivel nuts. No straps to bother with in opening.

See the new Kamlee at your dealer's. If he doesn't have it write for prices and booklet.

**THE KAMLEE COMPANY**  
286 Broadway, Milwaukee, Wis.

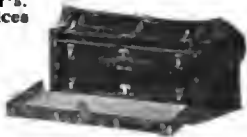

Look for this trade mark on lower right corner of trunk.

# BY ACTUAL TEST

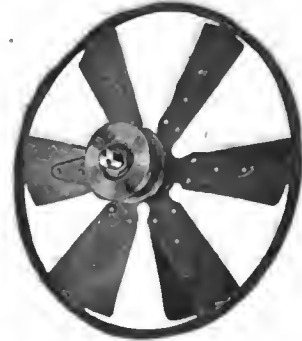

Patented

The Sparks-Withington One-Piece-Blade RADIATOR FAN will deliver a greater volume of air with less H.P. consumption than any other fan on the market. Bonafide tests furnished to those interested.

With this assurance, and considering that we are specialists in fan construction, where you are not, we desire the opportunity only to prove our claims and therefore, request your blue prints or a sample fan for estimate. Out of ten standards no doubt we can give you something without making special tools. That would mean a saving to you.

*We will gladly test free of charge and submit report on fans you now employ.*

*Don't fail to write us when you are ready to consider 1912 contract.*

**THE SPARKS-WITHINGTON CO., Jackson, Mich.**

Battery Boxes      Brake Drums      Flanges  
Ball Bearings      Hubs Complete      Heavy Stampings

# Automobile Parts

Specialization means Superiority

## OUR PRODUCTS:

- Pistons
- Piston Rings
- Piston Pins
- Transmission Gears
- Cam Shafts
- Motor Gears
- Valves



producing a large volume of Automobile and Motor Machine Parts, we offer you a superior product at a consistent price, and rid your factory of troublesome details.

Let us also submit estimates on your die-cast Bearing Bushing requirements. We

have a special department of our business devoted to this product.

We make a special point of Helical Cut Motor Gears, the only correct solution of the motor gear problem, and Integral Cam Shafts, with Cam Contours ground after hardening.

**THE F. W. SPACKE MACHINE CO.**  
INDIANAPOLIS, IND.

# Insist on Seeing the Oil in the Barrel or Can

THERE is absolutely only one way to make sure you are not buying poor oil—are not having a dealer offer you poor oil claiming it to be Monamobile Oil—that is to see with your own eyes the Monamobile trade-mark on the can or barrel from which the oil you use comes. Thousands have learned that ordinary oil fouls a motor—that we guarantee Monamobile Oil to run a car a whole season without fouling the engine.

## MONAMOBILE OIL

This is the Trade-Mark to Remember

Monamobile Oil is the finest engine oil. It is possible to make—compounded by experts—the great non-fouling oil—which holds to the surface of contact under the highest running pressure—stands an exceptionally high fire test—saves 50 per cent oil up-keep—is the highest priced oil on the oil market—costs the user no more than so-called first-class oil. Although it costs the dealer more money than other oils, he can sell it and make a legitimate profit at the same price as other brands. Many dealers attempt to make 200 per cent on oil—sell 25-cent oil for 75 cents per gallon. Insist on Monamobile Oil and get better value all around. Monamobile Oil will make a world of difference in the power and smoothness of your motor, particularly in its ability to "pick up." Our book on engine lubrication sent free to any address.

To Dealers: We sell direct to reliable dealers who do not substitute cheap oil furnished by brokers, jobbers or low grade refiners. We aim to protect our consumers and our dealers by urging the former to buy Monamobile Oil only from cans or barrels bearing the Monamobile trade-mark. All dealers selling Monamobile Oil enjoy the best patronage in their localities—build up a fine trade quickly. Dealers not now selling Monamobile Oil should write for our proposition now.

MONARCH MANUFACTURING CO.  
Box 102, Council Bluffs, Ia. Toledo, O.  
St. Paul, Minn.      San Francisco, Cal.



# Cino

## The Most Powerful Car of Its Size in the World

Such is the distinction which individualizes the CINO, a car of proven superiority over everything in its class. No other motor gives the same power in relation to bore and stroke. Our records in various contests have proven this. A most symmetrical combination of power, structural strength, durability and graceful design, typical of the highest mechanical art—for which Cincinnati is famous.

Send for Catalogue.

HABERER & CO., Cincinnati, O.



Buy  
**AMALIE**  
Non-Carbonizing  
Cylinder Oil  
T. B. Q. Non-Fluid Oil

for your auto and prolong the life of your car and lower its upkeep cost.  
ASK YOUR DEALER

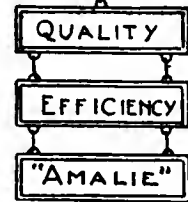

Oilworks: L. Sonneborn Sons, Inc., New York, N.Y.  
Baltimore, Philadelphia, Boston, Atlanta, Los Angeles.  
Texas Representatives: Sonneborn Bros., Dallas, San Antonio.

TRANSMISSION JACK SHAFTS  
WHEEL BRAKES  
BRAKE DRUMS  
AND  
SPROCKETS.

DIFFERENTIALS  
AND  
PLANETARY  
TRANSMISSION  
GEARS

THIS IS OUTFIT NO. 358  
SUITABLE FOR 1 TO 2 TON TRUCKS  
20 TO 40 HORSE POWER  
SAMPLE OUTFIT FOR \$140.00

WITH SLIDING GEAR TRANSMISSION  
THREE SPEED FORWARD ONE REVERSE  
40 HP 60 HORSE POWER  
SAMPLE OUTFIT FOR \$155.00

A WHEEL BRAKE that takes the place of  
1st A Rollin Rod  
2nd A Torque Bar  
3rd A Distance Rod  
4th A Brake Support  
5th A Chain Tensioner  
6th It is easily and quickly fitted.  
7th It drives when going "ahead".  
8th It pulls when "backing up".  
9th It carries all the TORQUE and TWIST,  
10th Carries the TORQUE above the spring.  
11th Releases the spring of this awful duty.  
12th Saves the Clip from loosening and opening off.  
13th Has a rolled connection at front end.  
14th Is adjusted to take up slack or add a link.

HEAVY BUILT  
SLIDING GEAR  
TRANSMISSIONS  
3 SPEEDS FORWARD,  
ONE REVERSE  
FOR 20 TO 60  
HORSE POWER, FOR  
TRUCKS CARRYING  
1 TO 4 TONS

SEND 10 CTS. IN STAMPS FOR LARGE CATALOGUE

MUNCIE GEAR WORKS, MUNCIE, IND.

# SPLITDORF

## MAGNETO

"Always there"

### Just Remember

That the WORLD'S RECORD for a road race, 74.65 m.p.h., was won and is held by Harvey Herrick with his SPLITDORF EQUIPPED National at Santa Monica, Cal., October 14, 1911,—

That the 1911 STOCK CAR CHAMPIONSHIP was won by Len Zengel and his SPLITDORF EQUIPPED National at Elgin, Ill., August 25, 1911,—

That the TOURING CHAMPIONSHIP—the 1911 GLIDDEN TOUR, was won by three SPLITDORF EQUIPPED Maxwells,—

And REALIZE OUR SUPREMACY.

Write for Catalog

**C. F. SPLITDORF**

Walton Ave. and 138th St.  
Branch 1679 Broadway NEW YORK  
CHICAGO BOSTON LOS ANGELES  
DETROIT KANSAS CITY SAN FRANCISCO



# Veeder

## HUB ODOMETER

A positive mileage recorder. Cannot be tampered with. No gears to unmesh. Cannot remove odometer, since the cap is sealed on, nor can the record be run back by jacking up and running the wheel backward, for the odometer records forward irrespective of the

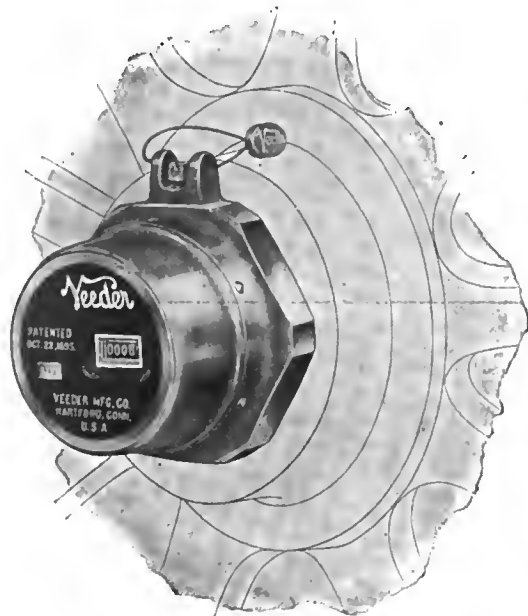

direction in which the wheel runs. Prevents JOY RIDING and is indispensable for Commercial Cars and Taxicabs.

Price, \$25.00, at your dealers, direct from the factory or from the following depots:

T. H. CRANSTON & CO.  
56 E. Randolph St., Chicago, Ill.

L. H. & B. I. BILL  
543 Golden Gate Ave., San Francisco, Cal.

THE RUBBER TIRE WHEEL CO.  
Montreal, Quebec, Toronto, Winnipeg and Vancouver

**The Veeder Manufacturing Co.**  
HARTFORD, CONN.

Makers of Cyclometers, Odometers, Tachometers, Tachometers, Counters and Small Die Castings.



MEANS

# SURE-LIGHT

Side or Tail Lamps

VENUS  
TAIL LAMP

It doesn't matter which.



When a man starts out with

## HAM'S LAMPS

on his auto he *knows* he is not going home in the dark.

If interested write.

**C. T. HAM MFG. CO.**

ROCHESTER, N. Y.

# Lauth-Juergens

QUALITY

DURABILITY

ONE, TWO AND THREE TON CAPACITY

LAUTH-JUERGENS TRUCKS ARE THE LATEST IN CONSTRUCTION, most powerful in operation and the motors are guaranteed against defective workmanship and material for the life of the truck. They are positively the highest class trucks made. Two cylinder, one-ton, four-cylinder, one, two and three-ton. Four speeds forward, Hess-Bright hall bearing transmission made in our own shops of the finest tool steel, three-piece disc clutch, covered by patents owned by us. Send for 1912 Catalog and specifications. Prompt delivery on all models. Large publicity campaign just begun. Our quality will do the rest.

Reliable Agents: Secure Your Territory for 1912 at Once.

BOSTON: Branches and Agencies: CHICAGO: Lauth-Juergens Motor Co. of New The Lauth-Juergens Motor Car England, 9-11 Harcourt Street. Co., 2630-32 Wabash Ave. NEW YORK: NEWARK, N. J.: West Side Garage & Motor Co., Merchants Motor Car Co., Essex Building, 160-162 101st Street.

Lauth-Juergens Trucks are Delivery Insurance



The Lauth-Juergens Motor Car Co. Fremont Ohio



# Hupmobile

**Prices Include Complete Equipment**  
of fore-doors, top, windshield, gas lamps,  
generator, three oil lamps, horn and tools.  
All models have 4-cylinder, 20 H. P.  
Motor, Sliding Gears and Bosch Magneto.

Runabout . . . . . \$750    Touring Car . . . \$900  
Torpedo . . . . . 850    Coupe . . . . . 1100

Fore-doors on Runabout and Touring Car

**HUPP MOTOR CAR CO.**, 1252 Jefferson Avenue, Detroit, Mich.

## The Practical Gas Engineer

WHAT TO DO AND HOW TO DO IT. A book of 192 pages,  
neatly bound in cloth. Sent postpaid for \$1.00. Address  
The Automobile, 231-241 West 39th Street, New York.



FOR SAFETY'S SAKE USE  
**NOBBY TREADS**  
They Hold on Any Road

yes, even on the slipperiest,  
greasiest stretch of asphalt  
you ever struck.  
It's the knobs that make them  
the strongest tires in the  
world.

**UNITED STATES TIRE COMPANY**  
NEW YORK



## High Tension Magneto

Model J  
Guaranteed  
to Start  
4 Cyl. Auto  
upto 30 H.P.



No Coll  
No Timer  
No Batteries  
4 Cyl. \$50  
6 Cyl. \$55

### Absolute Synchronism and Perfect Results at All Speeds

Extremely simple—nearly half less parts than any other Magneto. Perfectly reliable.

We also make larger Magnetos for larger engines.

If you cannot gear-drive a High Tension Magneto, use one of our \$35.00 Low Tension belt or friction drive Magnetos and a K-W Spark Coll.

**ELECTRIC LIGHTS** can be run from K-W Low Tension Magnetos. Ask us about it. High Tension Magnetos are for ignition only.

We have a special Electric Lighting outfit for Ford cars for \$15.00.



Low Tension . . . . . \$35.00  
Belt or Friction Drive.  
Used with K-W Colls. NO  
Moving Wires. NO Brush-  
es. NO Commutator. Runs  
in ball bearings. Starts  
engine without batteries.  
Runs Electric Lights at  
night.



The K-W Spark Coll.  
Has its Winding  
**Guaranteed Forever**  
against breakdown  
4-cylinder . . . . . \$30.00  
2-cylinder . . . . . 18.00  
1-cylinder . . . . . 12.00  
Marine Colls, \$6.00 & \$7.00

We make the Master Vibrator for FORD CARS.  
No matter what your ignition troubles are, we have a  
guaranteed cure.

WE PAY THE EXPRESS East of the Mississippi River  
or to the Mississippi on points beyond on any of our goods  
when cash accompanies the order.

Write for Catalogue

MAIN OFFICE AND FACTORY  
**THE K-W IGNITION CO.**  
2833 Chester Ave. CLEVELAND OHIO. U.S.A.

FOR SALE BY  
New York: A. H. Green & Co., 1686 Broadway  
Boston: Mr. W. J. Forbes, 70 Long Wharf  
Philadelphia: The Vail-Schaefer Co., 608 Arch Street  
Baltimore: H. F. Parker & Co., 633 W. North Ave.  
Washington: Miller-Dudley Co., 735 13th St., N. W.  
San Francisco: Weinstock-Nichols Co., 575 Golden Gate  
Ave.  
Los Angeles: Weinstock-Nichols Co., 1216 S. Olive St.  
Buffalo: J. W. Frey Auto Co., 700 Main Street  
Syracuse: Syracuse Rubber Co.  
Portland, Ore.: Robert Machy, Co., 281 E. Morrison St.  
Kansas City: Kansas City Auto Supply Co.  
Omaha: Powell Supply Co.  
New Orleans: Interstate Electric Co.  
Cincinnati: L. E. Bedinger, 311 Main Street  
Canada: Canadian General Electric Co., Toronto

# FISK

## Pure Para Inner Tubes

**Longer Lived Than Any Other, Says Ohio Dealer.**

"We find that Fisk tubes are longer lived than any other. We have a great many users whose Fisk tubes are over four years old and the rubber is still bright and lively." *Name on Request.*

*Inquire among  
Fisk Tire  
Users before you  
buy again.*

**THE FISK RUBBER COMPANY**

**Department C**

**CHICOPEE FALLS, MASS.**

*Direct Factory Service in 34 Cities*

# "A C STAR" SPARK PLUGS



**"A CHAIN IS  
AS STRONG AS ITS WEAKEST  
LINK"**



and your ignition system is only as strong as its weakest part. Why not strengthen the spark plug "link" by installing "A C STAR" spark plugs in your present equipment? A majority of the leading manufacturers are using "A C STAR" spark plugs as standard equipment on their 1912 product. Our illustrated booklet is yours for the asking.

**CHAMPION IGNITION COMPANY, Flint, Michigan, U. S. A.**

# Tear This Off

# You Need

# To Remind You

# Speedo

## IT'S GUARANTEED

### REMINDER

If my dealer hasn't SPEEDO I will order one direct, Stating h.p.

International Accessories Corporation.

Chicago Branch:  
Fulton-Grubb Co.,  
1148 Mich. Bvd.

Amount:  
**\$3.50**

### A Wonderful Mechanism

Attached in five minutes on intake manifold. It breaks up and remixes the gas with a spray of air and injects additional air perfectly and automatically. Makes possible a rich low-speed mixture for cool weather. Fits every car. Saves money.

**PRICE \$3.50**

(High power models upward)

### Absolutely Guaranteed:

- 1—To Increase Power 20 Per Cent.
- 2—To Save 20 Per Cent. on Gasoline
- 3—To Remedy Carbonization
- 4—To Help Starting

See your Dealer or write  
International Accessories Corporation  
Chicago Branch:  
Fulton-Grubb Company,  
1148 Michigan Bvd.

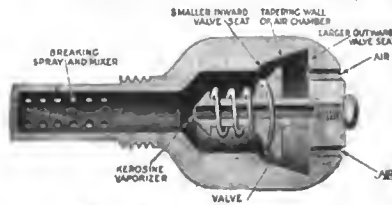

As Essential As the Carburetor

**SOLD ONLY UNDER AN ABSOLUTE GUARANTEE OF SATISFACTION** and upon return to seller price refunded may be had at any time within one year of purchase. **NO DEALER IS AUTHORIZED TO SELL OTHERWISE.**



Total Height, 30 in.; Length, 35 in.; Weight, 280 lbs.; Double Cylinder Air Compressor; Piston Rings; Splash Lubrication

# HERZ'S GARAGE PUMP

## 150 Pounds Compressed Air

*Holds Enough Air to Inflate Four Tires Outside of Garage*

Always ready for use. Just wheel it where it's needed, and connect to nearest lamp socket. It is made for any kind of current and costs practically nothing to run. No permanent pipe lines. No losses by leakage.

**HERZ & CO.,** Manufacturing Civil Engineers

**295 Lafayette Street, New York**

Please mention The Automobile when writing to Advertisers



## AN ANNOUNCEMENT

Owing to the inability of the APPLE ELECTRIC COMPANY to secure suitable space for their exhibit at the New York Automobile Shows, they will display their line at their New York store, No. 20 Vesey Street. All visitors will be cordially welcomed there.

In addition to the complete line of Aplco Automobile Electric Lighting Systems, Lamps, Fixtures, etc.,

### THE NEW APLCO ELECTRIC SELF-STARTER

will have its first public demonstration. It starts your engine. Lights your car. Furnishes current for ignition and signals. Can be seen in action on Inter-State cars.

### THE GOLDEN GLOW LENS MIRROR

The biggest feature ever added to an automobile lamp will be shown exclusively on Aplco Electric Headlights.

Aplco Electric Lighting Systems can be seen installed on Speedwell cars.

Don't forget the place—20 Vesey Street, New York City, during the Garden and Palace Shows. Our space at the Chicago Coliseum, No. 98. Boston, Mechanics Hall, 514 Dept. F.

**APPLE ELECTRIC COMPANY,** 16 North Canal Street  
Dayton, Ohio, U. S. A.

“IN THE HEART OF THINGS”

# HOTEL MARTINIQUE

ABSOLUTELY FIREPROOF

BROADWAY, 32d-33d STS., HERALD SQUARE, NEW YORK CITY

One block from New Penn. R. R. Depot and opposite HUDSON TERMINAL,  
connecting with Eric, Lackawanna, Lehigh Valley, Pennsylvania Railroads

FROM WHICH

BAGGAGE TRANSFERRED FREE TO AND  
FROM HOTEL

*In the midst of Leading Department Stores and Theatres*

**600 ROOMS. 400 BATHS**  
ROOMS WITH PRIVATE BATH  
**\$2.50 Up.**

The table d'hôte Breakfast  
at 60c. a Specialty

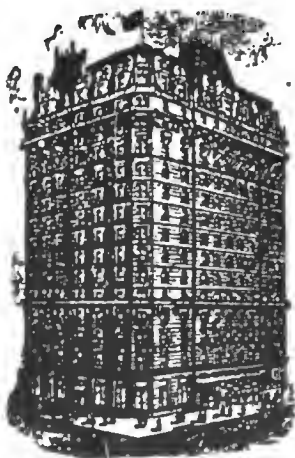

Write for further particulars and latest map of New York City free

CHAS. L. TAYLOR, PRESIDENT      W. S. GILSON, VICE-PRESIDENT  
WALTER CHANDLER, JR., MANAGER  
ALSO PROPRIETORS OF ST. DENIS HOTEL

# SPEAKING OF WIND SHIELDS



VISIT Space 301, Concert Hall, and see the latest addition to Col. Sprague's Famous Line of Wind Shields. The Cheapest Shield on the market. Made with a drawn steel tube frame, with either Nickel or Enamel finish. Automatic disc spring hinge lock. Guaranteed to hold upper section rigid in any position. Plate Glass. This Shield can be furnished in brass also. Write us for catalogue and discounts.

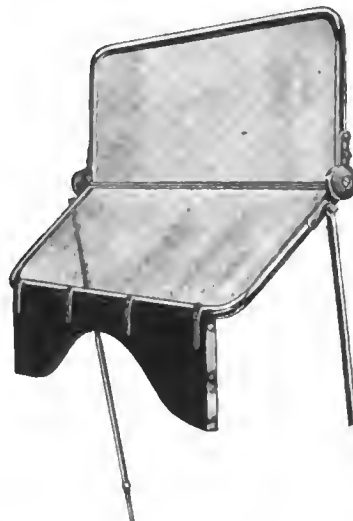

**THE SPRAGUE UMBRELLA & MFG. CO. NORWALK OHIO**



**Torpedo Type**  
Patented Sept. 5, 1911.

## Put a "NEWTONE"

on Your Car—Standard Equipment for 1912 Cars

Price \$20.00 Complete, including Button and Cable

THE BEST ACCIDENT INSURANCE

*Its musical note can be heard a mile away*

**INSURES** EFFICIENCY IN WARNING  
ECONOMY IN OPERATION  
STYLE TO YOUR CAR

No Automobile whether of foreign or domestic manufacture is complete without a Newtone Motor Horn.

Specify *Newtone* in your equipment. Its tone is clear, sweet and musical—yet so powerful that it can be heard a mile away. It warns without startling—and its novel design adds grace and beauty to any car.

### ABSOLUTE SATISFACTION IS GUARANTEED

Manufactured and guaranteed by the largest manufacturer of automobile horns in America—a firm that for the past 8 years have made, and are still making, over 80 per cent. of the horns now in use in the United States.

If your dealer does not carry the Newtone let us send you one on approval.

If not entirely satisfactory return at our expense. **The Newtone is unqualifiedly endorsed by every user.**

**Automobile Supply Manufacturing Co. 220 Tenth Ave. near Duane Ave. Brooklyn, N. Y.**



# KINWOOD WINDSHIELDS

Made by The Manufacturer of one of the most comprehensive lines of Auto Parts in America

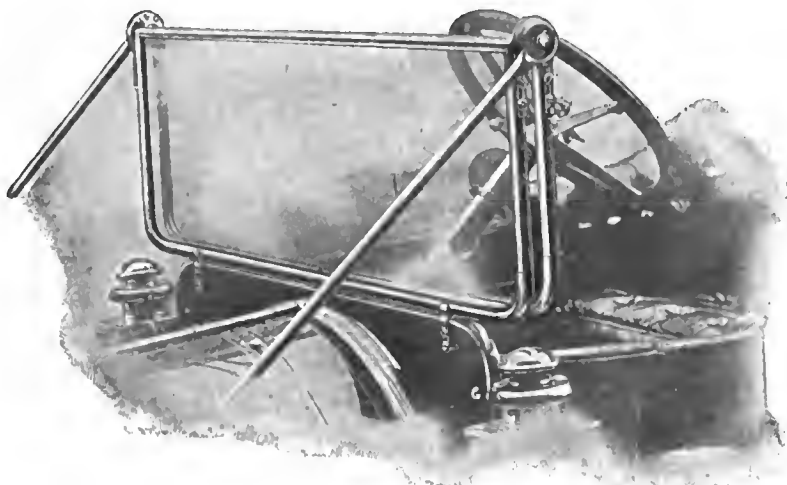

Don't delay in sending for 1912 Proposition on KINWOOD WINDSHIELDS.

We have something in this proposition mighty convincing to the Trade.

You can't afford to omit looking over this Proposition because we are a big factor in the Windshield business today, and can help you in this end of your business nicely.

Write Now



We Shall Exhibit at Chicago Show January 27 to February 10

**THE KINSEY MFG. COMPANY  
TOLEDO, OHIO**

# PITTSFIELD

## High Tension Magneto

Free From Moving Wires

A high tension magneto, the sparks from which are followed by arc flames that ignite the weakest mixture instantly. The volume of flame never deteriorates and the heaviest engine may be started by a quarter turn of the crank without batteries.

The necessity for induction coil is eliminated as the high tension current is generated in the magneto coil which is stationary, the armature being free from moving wires.

This is a completely new design in magneto construction and its accuracy, effectiveness and dependability are accountable for the great and increasing demand for the Pittsfield Perfected Magneto.

**PITTSFIELD SPARK COIL CO., Dalton, Mass.**

SALES REPRESENTATIVES—\*New England States, William J. Connell, 555 Boylston St., Boston, Mass. At anti: States, Thomas J. Wetzel, 17 W. 42nd St., New York City. \*Central States, Brown & Caine, 1517 Michigan Ave., Chicago, Ill. \*Pacific States, Chanslor & Lyon Motor Supply Co., San Francisco, Los Angeles and Fresno, Cal., Seattle and Spokane, Wash., Portland, Ore. \*Canada, Russell Motor Car Co., West Toronto, Canada. \*Pull line carried.

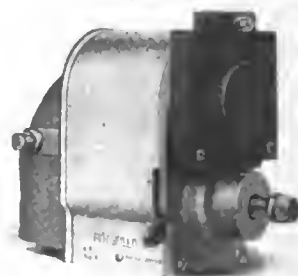

Type B

Obtain our catalogue illustrating the most perfect ignition system ever designed. On request.

Please mention The Automobile when writing to Advertisers

# Ford Model T Delivery Car

By reason of established efficiency this Delivery Car fits into the wants of business like the telephone. It extends your business. It is simple in design and strong in mechanical construction. Cheap in operation—a glutton for work—and sold at a price that has created an almost universal demand.

# \$700

Fully Equipped

F. O. B. Detroit

This price includes full equipment—Automatic Brass Wind Shield, Speedometer, Ford Magneto built into the motor, two six-inch Gas Lamps and Generator, three Oil Lamps, Horn and Tools. No Ford Cars sold unequipped.

Capacity of this Universal Delivery Car is 750 pounds of merchandise.

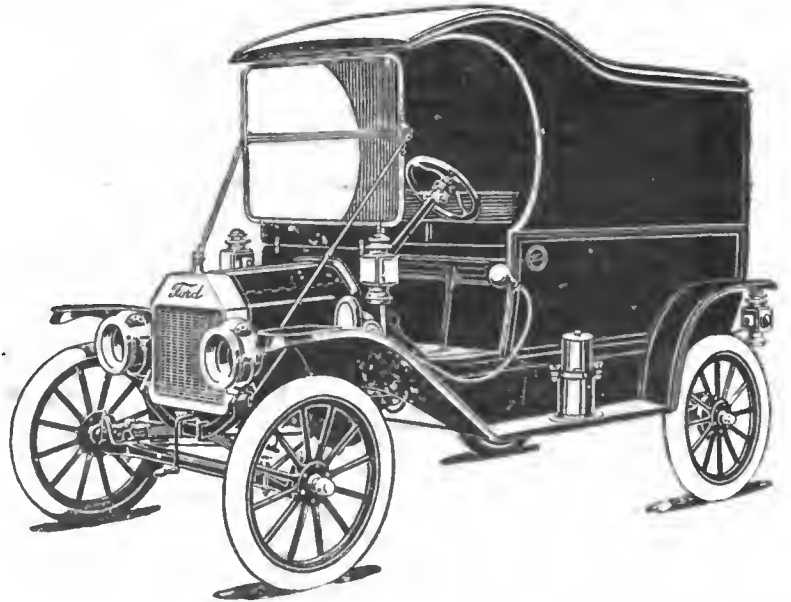

We did not offer Ford Model T Delivery Car to the business world until we had thoroughly tried it out in the very line of work that business makes for a Delivery Car. Now—after two years of experience in delivering merchandise—two years over city streets of all sorts—over country roads—in hilly territory in all sorts of weather—winter and summer—we know this car will “deliver the goods.” We therefore recommend Ford Model T Delivery Car with our broadest warranty as a dependable, economical, durable, convenient, money-saving delivery car—for the big store, for the little store—for the city, town, village, or country.

The purchase price is low, and the maintenance—

from facts established during continuous service—about five cents per mile.

At present we can make immediate delivery, but the way orders are coming in prompts the suggestion that you place your order without delay.

Ford Model T Delivery Car has the same Vanadium Steel Chassis which has made Ford cars so practically useful and popular the world over. It has a handsome pressed steel body with a merchandise carrying capacity of 750 pounds.

Four thousand Ford dealers scattered all over the country will give your order prompt attention!

## Fixed Prices on Quantity Orders For Ford Motor Cars for Commercial Purposes

To concerns who purchase Ford Cars in quantity lots for Commercial Purposes we will give the benefit of a rate reduction or discount—we have fixed a sliding scale of prices which will be submitted on request. Catalogs and detailed descriptive literature will be mailed gratis. Branch Houses and Large Distributors in all Principal Cities—Dealers Everywhere.

# Ford Motor Company

Detroit, Michigan, U. S. A.

Please mention The Automobile when writing to Advertisers.

**SIT IN YOUR SEAT**



**AND PUSH A  
BUTTON**

**HAVE  
ELECTRIC LIGHTS**

**CONVENIENT—RELIABLE—CLEAN**



USE THE

**GLBA**

**ELECTRIC LIGHTING BATTERY  
WITH AN  
ELECTRIC LIGHTING GENERATOR**

Write us for full information

**WILLARD STORAGE BATTERY COMPANY  
CLEVELAND, OHIO**

NEW YORK BRANCH 136 W. 52nd St.

DETROIT BRANCH. 1191 Woodward Ave.

CHICAGO BRANCH: 436 So. Dearborn St.

Please mention The Automobile when writing to Advertisers

Digitized by Google



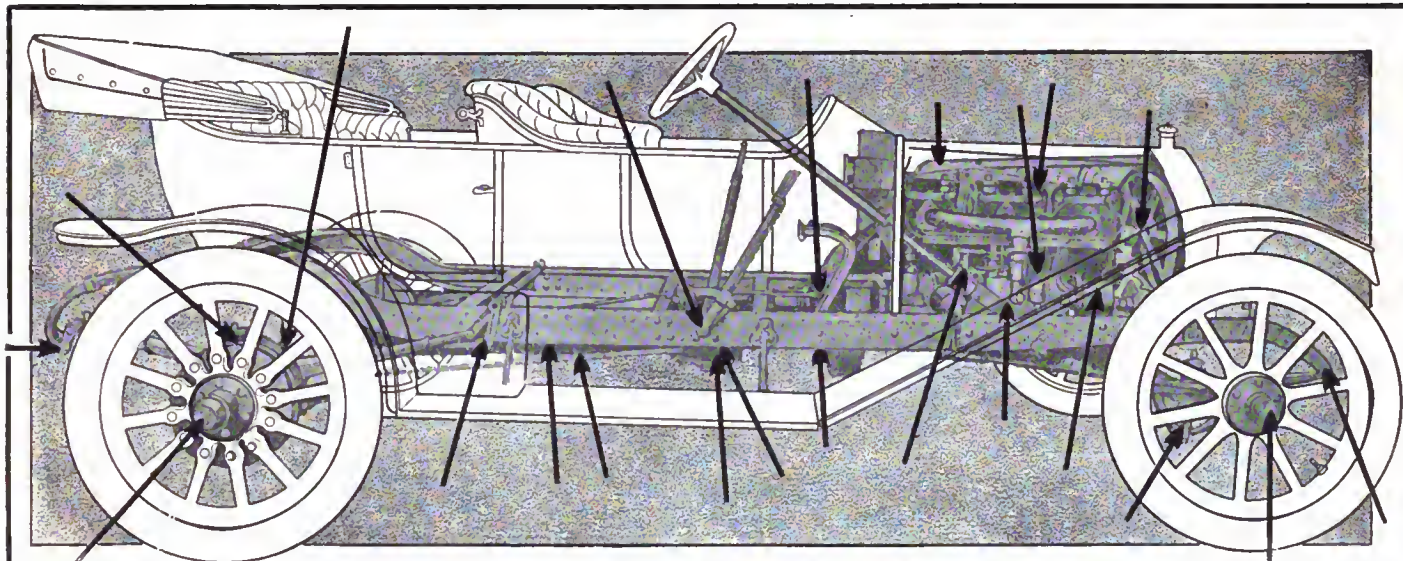

This illustration indicates the location of the oiling points of a motor car (the number and location of these points vary in different types of cars). Unless properly lubricated an automobile will give trouble and soon wear out.

## “Spare the Oil and Spoil the Car”

**P**ENNIES saved on oil or grease may mean dollars spent in up-keep—not to mention annoying delays or the shortened life of your car.

For motorists who recognize the economy of using the best oil we have produced Polarine.

It is not a low-priced oil. But in the long run it will prove sound economy.

Polarine Oil goes through special processes of distillation, pressing and reducing. It is then carefully cleaned and filtered to remove impurities and free carbon. This secures the correct lubricating qualities for gas engine use.

Polarine leaves no appreciable carbon deposit.

Its consistency or “body” is not materially affected by either high or low temperatures. It flows freely down to zero.

# Polarine

The Polarine Brand covers:

**Polarine Oil** (in five gallon, gallon and half-gallon sealed cans),  
**Polarine Transmission Lubricants**, **Polarine Fibre Grease** and  
**Polarine Cup Grease.**

These lubricants cover the needs of every part of the car.

Send to our nearest agency for “Polarine Pointers,” which include hints on the care of motor cars.

## Standard Oil Company

(Incorporated)



Polarine Oil. For all types of gasoline engines. Delivered in sealed cans—five-gallon, gallon and half-gallon sizes.



Polarine Transmission Lubricants. Prepared in three consistencies, “A,” “B,” “BB.” The cans are of convenient size.



Polarine Fibre Grease, Polarine Cup Grease. Delivered in round cans.

More information in our booklet. Send for it.



# The Jack that Hartford built

## That's the Jack for You!

The **Hartford Jack**—the jack with the **long arm** and **short stroke**—no back-breaking, arm-aching work with the Hartford.

Look at the inside construction of the

# Hartford Auto-Jack

Equip your car with the

## Truffault-Hartford SHOCK ABSORBER

FOUR MODELS

Standard for cars over 2500 lbs. per set of four.....	\$60
Intermediate for cars from 1800 lbs. to 2500 lbs.....	\$45
Junior for smaller cars weighing 1200 lbs. to 1800 lbs.....	\$25
Juniorette for small cars like the Ford, AA Maxwell, Hupmobile, etc.....	\$15

Our new catalog, just off the press, will make all this clearer in an interesting way. Beautifully illustrated. Write us for a copy today.

### Buy the Easy Riding Car

Don't think because you happen to be buying a small and inexpensive car that it must necessarily be a hard riding machine. Get a demonstration of several makes of cars and compare their riding qualities. Give this feature your special attention in deciding which car you intend to purchase, because with properly designed springs and Shock Absorbers the car you buy can be made to ride as smoothly as one of the highest priced cars. An easy riding car not only means motoring in comfort, but considerably less expense for upkeep, tires and repairs. Think this over.

So simple—it simply *can't* get out of order—and made so well and of such fine materials it lasts a lifetime.

So scientific—it takes only *one-third the effort* an ordinary jack requires.

And equipped with a *mechanical* reversing device so that you know positively your car will go up or down as you want—no guesswork.

Be sure you get the Hartford—then you're sure to have the best—the jack that's always ready to use—the jack that never slips, shakes or lets go its grip.

## Sold by Dealers Everywhere

You will find the Hartford for sale by most dealers—but if your dealer does not carry it, we will send you one direct on receipt of price—with the strict guarantee that your money will be immediately returned to you if for any reason you are not entirely satisfied with your bargain.

Price, complete with strong canvas containing bag . . . . **\$8**

## Hartford Suspension Co.

E. V. Hartford, President 140 Bay St., Jersey City, N. J.

New York, 1700 Broadway,  
212-214 West 88th St.  
Chicago, 1458 Michigan Ave.  
Boston, 325 Columbus Ave.  
Philadelphia, 1437 Vine St.  
Newark, 289 Halsey St.





# If You're Endorsing

the *wrong* speedometer—a speedometer that *costs more* than the *Stewart* (and isn't half as good as the *Stewart*)—you may find yourself in the position of the Irishman who grabbed the wild-cat; you won't want help to *hold* it—you'll be calling to your friends to help you let it go.

Begin at the right time — *now* — and get the right speedometer, *now*.

The *Stewart* is fit for us to guarantee, and so it's fit for you.

The *better* the car, the more reason to equip it with the *Stewart*.

We could not make it *more* satisfactory if we made the selling price a thousand dollars.

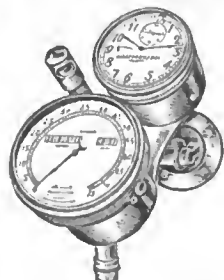

Speedometers, \$15 to \$30  
Clock Combinations, \$45 to \$70

Stewart Speedometers are attractive—beautifully made—open dials—large figures—easily read—absolutely accurate; 100,000-mile season odometer; 100-mile trip register, can be set back to any tenth of a mile. Strongest flexible shaft, drop forged swivel joints (an exclusive feature), quiet road wheel gears.

**"ALWAYS ON THE JOB."**

## Stewart & Clark Manufacturing Company

1852 Diversey Boulevard, Chicago, U. S. A.

Detroit	San Francisco	New York	Los Angeles	Chicago	London
Cleveland	Philadelphia	Minneapolis	Indianapolis	Kansas City	Paris



Please mention The Automobile when writing to Advertisers

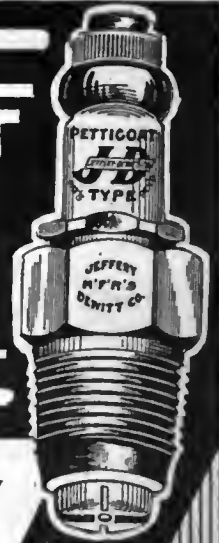
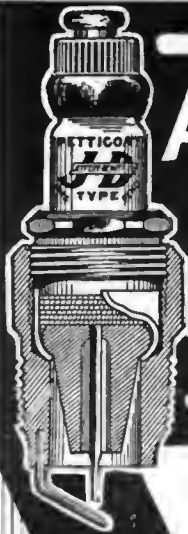

# A COMPLETE LINE OF SPARK PLUGS

EFFICIENT-DURABLE-ECONOMICAL

**"J. D." Spark Plugs at 75c are the Best Buy on the Market Today**

The mechanical principles involved in the working of "J. D." Spark Plugs represent the best ignition practice. Therefore, since the "J. D." plugs are made entirely in our own plant, we can and do guarantee them to be as perfect as the best materials and workmanship can make them. The motorist can select any one of the three types of "J. D." plugs—Petticoat, Closed End or Conical. They are all sold at the same price and the same iron-clad guarantee goes with each one.

**"Your money back or a new plug if you are not satisfied."**

The porcelain in "J. D." plugs is made in our own pottery and is positively heat-proof. The open market cannot be depended on for the consistent excellence of the porcelain used in "J. D." Plugs. And we are the only makers of spark plugs making our own porcelain from the raw material.

If your dealer hasn't "J. D." plugs in stock, we will send them to you on receipt of price.

**Jeffery Dewitt Co.**  
52 Butler Avenue,  
Detroit, Mich.



**75¢**

Please mention The Automobile when writing to Advertisers

# POSITIVE STARTING

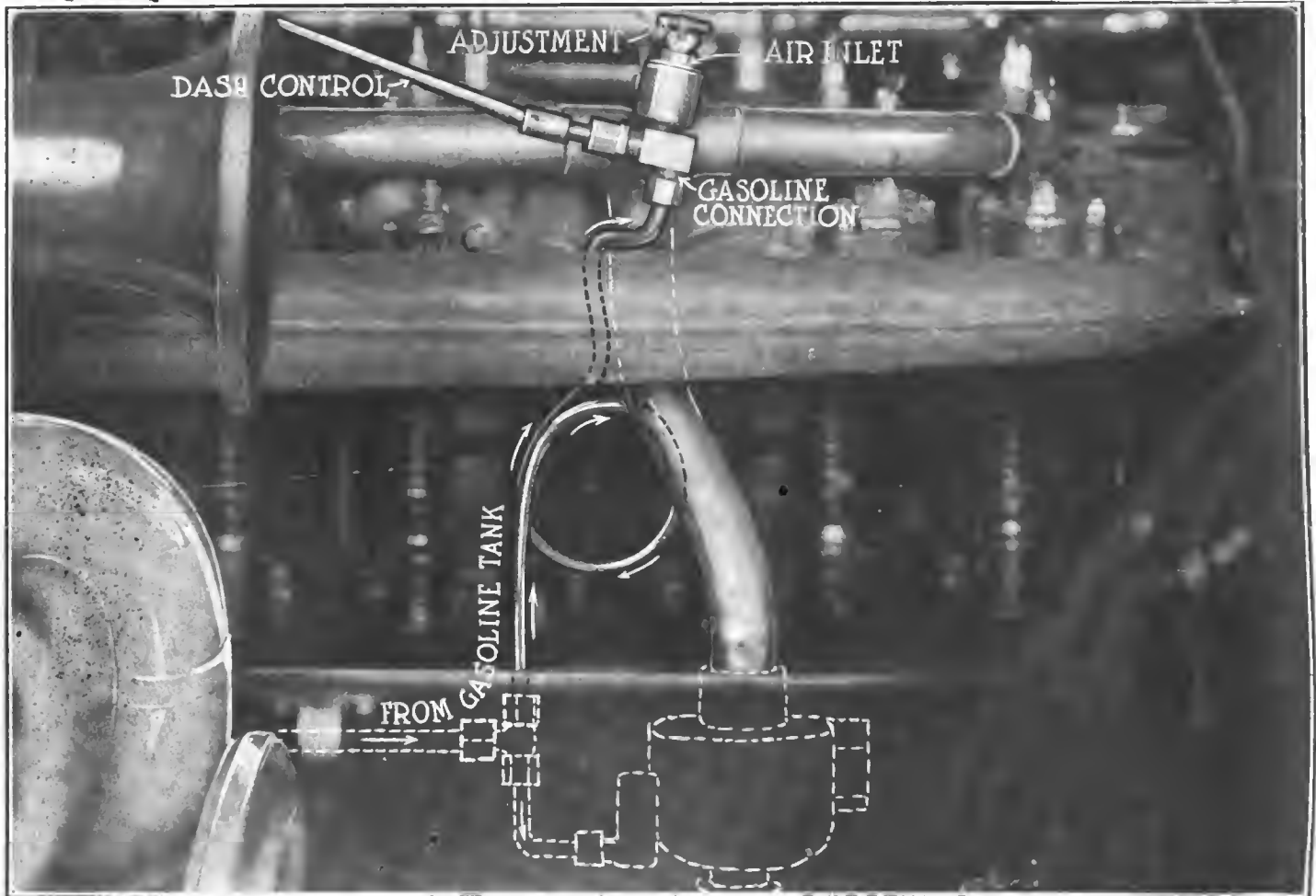

## BY THE AUTOMATIC PRIMER

Have you discovered that your starting difficulties are largely due to the fact that your motor is not supplied with the correct mixture at the time you turn it over? Whether you crank your motor or use an automatic starter, you must have THE AUTOMATIC PRIMER if you want positive starting every time.

THE AUTOMATIC PRIMER is a device which supplies the gasoline direct to the cylinders—entirely independent of the carburetor. It is operated by a valve from the driver's seat; it automatically primes the motor regardless of the temperature of the weather, without the use of auxiliary tanks, air pressure, or pumping device.

THE AUTOMATIC PRIMER saves so much gasoline that it pays for itself in a short while. Its saving is due to the fact that the additional gasoline required in starting and warming up your motor to a normal condition comes through the primer, thereby leaving the most economical adjustment of the carburetor undisturbed.

With THE AUTOMATIC PRIMER we guarantee that in 50 50% of the cases you will start from the spark and in 95% of the other cases you will start on the first time you turn your motor over.

THE AUTOMATIC PRIMER has been tried out so thoroughly and has been so universally appreciated that we feel justified in telling you of its wonderful merits and guaranteeing its usefulness.

We will express you the primer with all its necessary connections, so that all that it is necessary to do in order to connect it is to tap your manifold and connect your gasoline line, which can be done without cutting or threading the pipe. The dash bracket is fitted on with three wood screws, you can put THE AUTOMATIC PRIMER on the car yourself in a very few minutes.

The price is \$6.00 complete. With every primer is furnished instructions for installation and operation. Try it 30 days and if not entirely satisfactory return it and we will refund your money. Sent C. O. D. if so desired.

Enclosed please find \$6 for which send me on approval your AUTOMATIC PRIMER. It is understood that money will be refunded any time within thirty days from date of purchase if the device is in the least unsatisfactory.

**The Automatic Priming Device Company**

1507 Michigan Ave., Chicago, Ill.

Name .....

Add .....

Name of car.....

Model .....

Please mention The Automobile when writing to Advertisers

# VANDERBILT CUP CARS

## Second Chapter of Facts

Published in the Interest of Honest Advertising

Last week we felt compelled to notice certain advertisements made in behalf of another manufacturer of ball bearings, claiming the use of those bearings in certain winning or placed cars in Vanderbilt cup races. Those advertisements were so worded as to give the impression that that make was sole or principal equipment in the cars named.

Since publishing our recent advertisement we have learned from the Lozier Motor Company that three minor transmission bearings in the winning and fourth placed Loziers in the recent race were not of our make. We do not seek credit not fairly earned, so we hasten to disclaim the credit.

### Now Regarding the Wishart Mercedes

We have since secured the entire set of ball bearings used in this car in the recent Vanderbilt race. They number 25, as follows:

19 annular bearings—	HESS-BRIGHTS
4 thrust bearings—	HESS-BRIGHTS
2 thrust bearings—	another make
<u>25</u>	

The last two thrusts are small bearings used in the *steering knuckles!* Truly, "it was a famous victory"—for HESS-BRIGHTS!

These same 25 bearings from the Wishart car will be at our exhibit at the Madison Square Garden show, where we shall be glad to show them to anyone interested.

## **HB** Here Is the Story to Date **DWF**

1908	Locomobile	HESS-BRIGHTS sole equipment.	Cup Winner.
1909	Alco	HESS-BRIGHTS " " " "	
1910	Alco	HESS-BRIGHTS " " " "	
1911	1 Lozier (Mulford)	HESS-BRIGHTS in engine and transmission, except 3 minor bearings.	Cup Winner.
	3 Mercedes (Wishart)	HESS-BRIGHTS throughout, except steering knuckle thrusts.	
	4 Lozier (Grant)	HESS-BRIGHTS, same as No. 1.	

It has been said of a certain class of advertisers that "they do not misrepresent; they merely exaggerate the truth."

But there is a point—in art or advertising—where "exaggeration" becomes caricature or worse.

Need We Point the Moral?

**THE HESS-BRIGHT MANUFACTURING COMPANY**



STANDARD OIL  
TROPHY



WINNER OF ALGONQUIN HILL CLIMB  
CLASS A 2-DIV 3  
PERFECT ROAD SCORE  
1000 MILE RELIABILITY

TELEPHONE KEDZIE 1833

H. E. HALBERT, PROP.

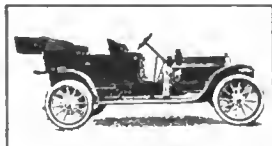

SALESROOM  
1408-10 MICHIGAN AVENUE  
TEL. CALUMET 4968

### Garfield Park Automobile Garage

DISTRIBUTOR

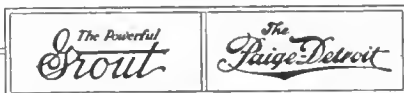

608-612 INDEPENDENCE BLVD.  
CHICAGO

EXPERT REPAIRING FULL LINE OF SUPPLIES FIRE PROOF STORAGE

Chicago, Ills.

Nov. 7th, 1911.,

Stromberg Motor Device Co.

64-68 E. 25th St.,

Chicago, Ills.

Gentlemen:-

With great pleasure I acknowledge the remarkable assistance the Stromberg Carburetor gave me in winning the Standard Oil Trophy for Fuel Economy in the Chicago Motor Club's Seven Day Reliability Run.

I made not a single adjustment to the Carburetor throughout the seven days, and we made 17.6 Miles per gallon with a heavy Car for the entire distance.

Again thanking you for the great assistance rendered by your Device, I am,

Yours very truly,

*H. E. Halbert*

You can  
do the  
same

### STROMBERG MOTOR DEVICES COMPANY, 64-66-68 E. 25TH ST., CHICAGO

NEW YORK BRANCH, Automobile Building, 1926 Broadway, at 6th Street. BOSTON BRANCH, Motor Mart, 91 Church Street. DETROIT BRANCH, 1211 Woodward Avenue. INDIANAPOLIS BRANCH, 514 North Capitol Avenue. NORTH-WESTERN BRANCH, 1514 Hennepin Avenue, Minneapolis. LOS ANGELES BRANCH, 943-7 S. Main Street. SAN FRANCISCO BRANCH, 307 Golden Gate Avenue.  
DISTRIBUTORS—Chanslor & Lyon Motor Supply Co., Los Angeles, San Francisco and Fresno, Cal. Seattle and Spokane, Wash., Portland, Ore. John Millen & Son, Ltd., Toronto, Montreal, Winnipeg, Vancouver, Post & Lester, Boston, Worcester and Springfield, Mass., Hartford, Bridgeport and New Haven, Conn. Auto Equipment Co., Philadelphia, Pa. Way-Mitchell-Rigdon Co., Cleveland, O. James G. Barclay, Buffalo, N. Y. Prince-Wells Co., Louisville, Ky. Von Ham-Young Co., Ltd., Honolulu, T. H. Kansas City Auto Supply Co., Kansas City, Mo. Phoenix Auto Supply Co., St. Louis, Mo. Auto Equipment Co., Denver, Colo. Coughlin & Davis, Cincinnati, O. Pittsburgh Auto Equipment Co., Pittsburgh, Pa. Mohler & DeGress, Mexico City, Mex. Auto Supply Co., Baltimore, Md. Sharman Auto Co., Salt Lake City, Utah. Fisk Co., of Texas, San Antonio, Tex. Omaha Rubber Co., Omaha, Neb. Syracuse Rubber Co., Syracuse, N. Y. Kelley Hardware Co., Duluth, Minn. Belcher & Loomis, Providence, R. I. A. H. DeBlaz & Co., Havana, Cuba. Alexander-Seewald Co., Atlanta, Ga.



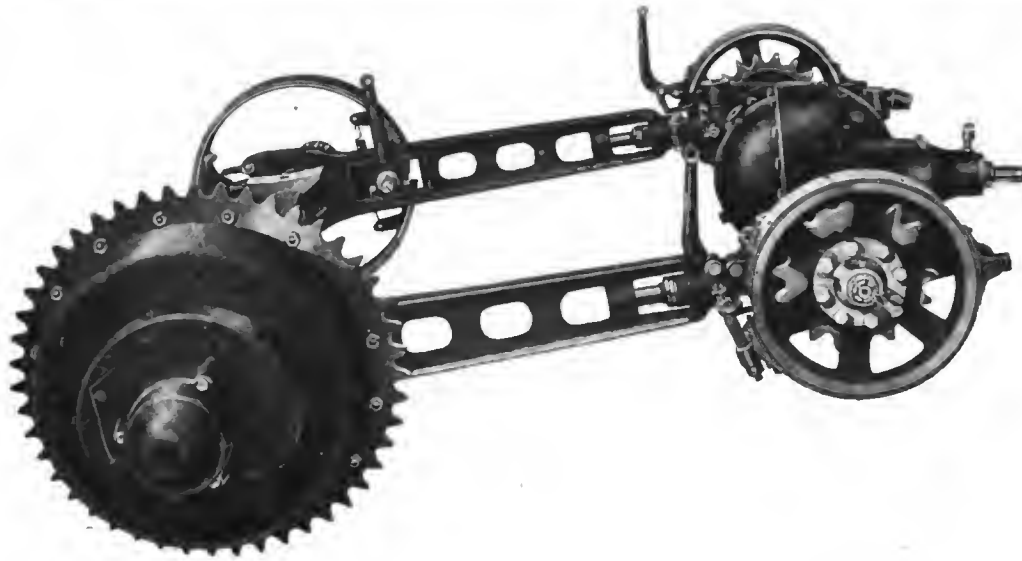

## Jack-Shaft Service Brake on Timken Rear Equipment for Commercial Trucks

The Timken Service Brake is mounted outside the chain. *It is easy to reach for adjustment.*

Its large diameter and wide face give extra generous braking surface. *It holds like a bulldog.*

The broad steel band is anchored in a strong arm projecting from that part of the radius rod which swivels over the jack-shaft housing. *It is anchored for all storms.*

There is slight adjustable play in the anchor and in the support at the toggle, so the grip is strong and even. *The brake can't cramp.*

The lining of homogeneous asbestos and copper wire has proved in Timken experience to wear like iron and never over-heat. *It takes hold easy, but grips like metal on metal.*

Timken-Detroit Axles and Timken Roller Bearings will be shown January 6th to 20th in booths 165-166, Madison Square Garden, New York City. Drawings and full details of Timken Rear Equipment may be had from our Engineering Department any time.

**THE TIMKEN-DETROIT AXLE COMPANY**  
DETROIT, MICHIGAN, U. S. A.

*The only axle manufacturer licensed to make axles equipped with the famous Timken Roller Bearings.*



Please mention The Automobile when writing to Advertisers

# Overland

**J**UDGED from every possible angle our \$900 thirty horse-power five-passenger touring car gives you just as much car, just as much comfort, just as much power and speed and just as fine construction as any \$1250 car of like type made.

A calm estimate of actual values—a careful comparison of specifications will prove this to be a positive fact.

Our model 59 is the greatest value on the market today. Write for book G 412.

The Willys-Overland Company, Toledo, Ohio

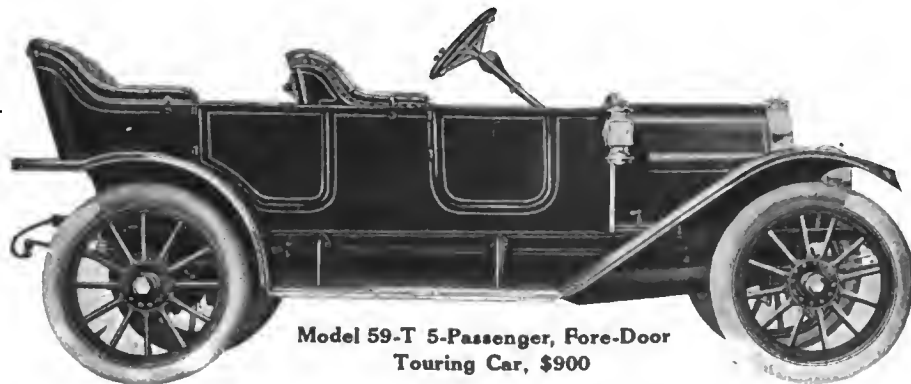

Model 59-T 5-Passenger, Fore-Door  
Touring Car, \$900

Wheelbase 106 inches; motor 6x4; horsepower 30; Spiltdorf magneto; transmission selective, 3 speeds and reverse; F. & S. ball bearings; tires 22x2; O. D.; 3 oil lamps, 2 gas lamps and generator. Complete set of tools.



**GMC**

MODEL K  
CAPACITY 5 TONS  
PRICE, CHASSIS ONLY,  
\$4400

## This truck is one unit of A Fifty-Ton Equipment

James Butler, Inc., the big New York chain store grocery house has ten trucks of this model, purchased in five orders over a period extending from January, 1910, to September, 1911. The oldest (shown above) and the newest are daily working side by side. So successful have these trucks proven that this concern recently placed on sale their entire remaining stable of heavy draft horses, 100 of them, for the purpose of replacing all with GMC trucks. The first purchase was this one truck; it has sold all the rest.

The best proof of the reliability, efficiency and economy of GMC trucks is in the fact of such repeat orders as this. The GMC line comprises both gasoline and electric trucks in capacities from 1,000 lbs. to 6 tons.

As a result of this complete line, this Company is in a position to recommend and supply the kind of truck best adapted to any given delivery or hauling requirement, without bias toward either gasoline or electric power or toward any one special type of construction.

GMC gasoline trucks are made in both standard types—

the lighter capacities with motor under the hood and the heavy-duty trucks with motor under the seat. We are prepared to handle your delivery problems in a comprehensive instead of a fragmentary way, supplying complete installments of delivery trucks, which, although possibly comprising several types, will be standardized under the one GMC mark. It is only with such a standardized system of delivery that the maximum efficiency and economy are possible, to say nothing of the advantages of dealing with a single manufacturer, with a single center of responsibility and service.

**GMC Gasoline and Electric Trucks will be exhibited at the New York, Chicago and Boston Shows.**

*Correspondence from prospective purchasers and dealers is invited.*



Please mention The Automobile when writing to Advertisers

# The *Detroit*

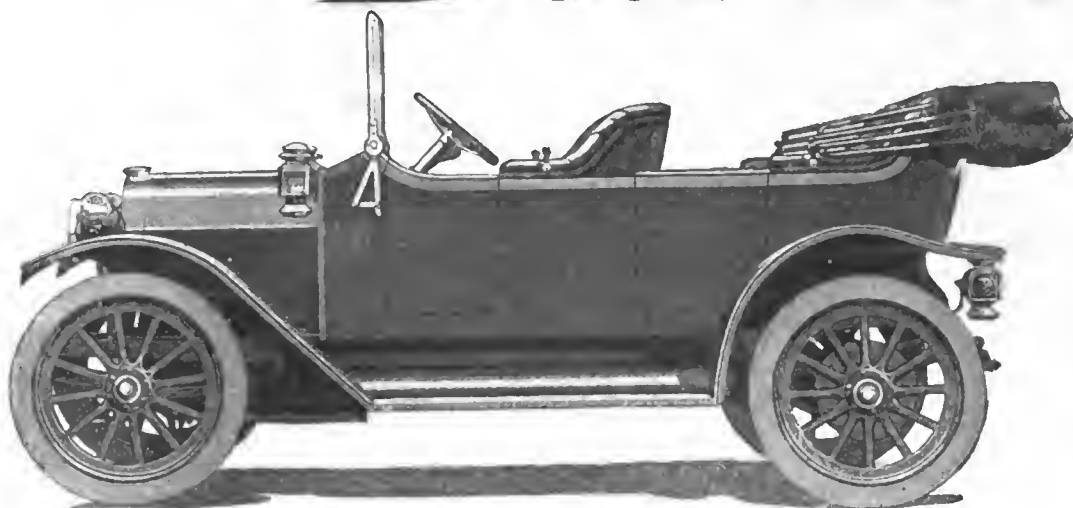

A 25-H.P. Touring Car—Ball Bearing Throughout

## \$850

(F. O. B. Detroit). Completely equipped with Top, Side Curtains, Windshields, 3 Oil Lamps, 2 Gas Lamps, Generator, Horn, Tools, Tire Repair Kit. The name typifies the best that the "Automobile Capital" affords, in designing skill, efficient manufacturing and in able financing.

## This New Car is Just a Little Better Than the Low-Priced Field Has Known

Satisfaction has never overwhelmed the users of low-priced cars. These owners have always felt that there was something to be desired. Maybe they wanted a stronger axle, more power, larger braking surfaces. Probably they wanted less noise. Maybe it was more room they wanted. Maybe easier riding. It seems at any rate that there was always something lacking—something that the owners of high-priced cars enjoyed.

Now comes the Detroit, profiting by the mistakes of the past, with a car that has eliminated these weaknesses. A new car, ball-bearing throughout, with a long-stroke, silent, powerful motor, pressed steel rear axle with gears that positively will hold up, abnormal braking surface, full platform springs in the rear and other high-class features seen only in cars selling at double the price.

The Detroit has no freak theories to exploit. Designing theories needed no upheaval. But the demand was for specifications that will insure safety, service and satisfaction.

The car is now on the market. It is built in a new factory by Claude S. Briggs, who with W. S. Lee designed the Detroit. Associated with them in this new Company is Emil D. Moessner and a coterie of the most experienced manufacturers in the automobile capital.

Dealers read the Detroit's specifications and see if you, too, do not regard this car at \$850 as the greatest proposition ever put onto the market. The announcement of this car and its builders has caused such a flood of inquiries and contracts that if you desire to handle this car in your territory write or wire at once for literature and dealers' proposition.

### SPECIFICATIONS

Motor—25 H.P.,  $3\frac{3}{8}$ " x  $4\frac{1}{4}$ ", bore and stroke cylinders cast en bloc.  
 Wheel Base—104 inches.  
 Gauge—56 inches.  
 Tires—32" x  $3\frac{1}{2}$ ".  
 Springs—Front, semi-elliptic.  
 Springs—Rear, full Platform.  
 Axle—Front "I" beam drop forged.  
 Axle—Rear, full floating.  
 Frame—Pressed steel, channel section.  
 Valve Arrangement—Enclosed, all on one side. Valves extra large, with special means of adjustment.  
 Fuel Supply—Gravity feed.  
 Ignition—Bosch magneto.  
 Lubrication—Splash feed, constant level.  
 Cooling—Thermo-syphon.  
 Radiator—Tubular, square front.  
 Motor Suspension—Three-point.  
 Clutch—Multiple disc.  
 Change Gear—Selective center control.  
 Speeds—Three forward and reverse.  
 Transmission—Unit with power plant.

**BRIGGS-DETROITER COMPANY, 451 Holbrook Avenue, Detroit, Mich.**

# RIMS 1912



TYPE No. 1



TYPE No. 2



TYPE No. 3

From the inception of the automobile industry, buyers of rims (including manufacturers as well as consumers) have looked upon us as an authority on this subject and await our annual announcement before placing orders. Because of this anticipation, and reliance in our statements, we make the following announcement:

**O**NE or another of the three types of Standard Universal Quick Detachable Demountable Rims shown on this page has been chosen by nearly every automobile manufacturer as STANDARD equipment for his 1912 car. These rims will fit ANY make of domestic automobile tire, either STRAIGHT SIDE or CLINCHER.

Type No. 3 you are familiar with and present indications are that it will be as popular during the coming year as it was in the past.

Types Nos. 1 and 2, which so quickly climbed into favor with the trade, are, from indications of orders received, going to remain in their present high position. The same felloe band is used on Types Nos. 1 and 2 and will accommodate the rim base or outer rim of either type. The side rings are reversible, accepting either straight side or clincher tires. The locking bolts used in the demounting feature are truly the most wonderful device employed for this purpose, a few turns securely fastening the rim into position.

To summarize, all three types are HIGHLY perfected and hundreds of sets are being shipped DAILY to ALL parts of the WORLD and giving SATISFACTION wherever used.

We shall have all three designs on exhibition at Madison Square Garden, New York, January 6th to 20th and at the Coliseum, Chicago, January 27th to February 10th. Your inspection of them we shall consider a great favor and you will be IMPRESSED by their PERFECT construction and HIGH efficiency.

NOTE—We shall reserve a *limited* number of our 1912 Show Booklets for those unable to attend either show. Postal request or your business card will secure a copy. *It is worth while.*

**THE  
STANDARD  
WELDING  
COMPANY  
CLEVELAND  
NEW YORK  
CHICAGO  
DETROIT**

Please mention The Automobile when writing to Advertisers



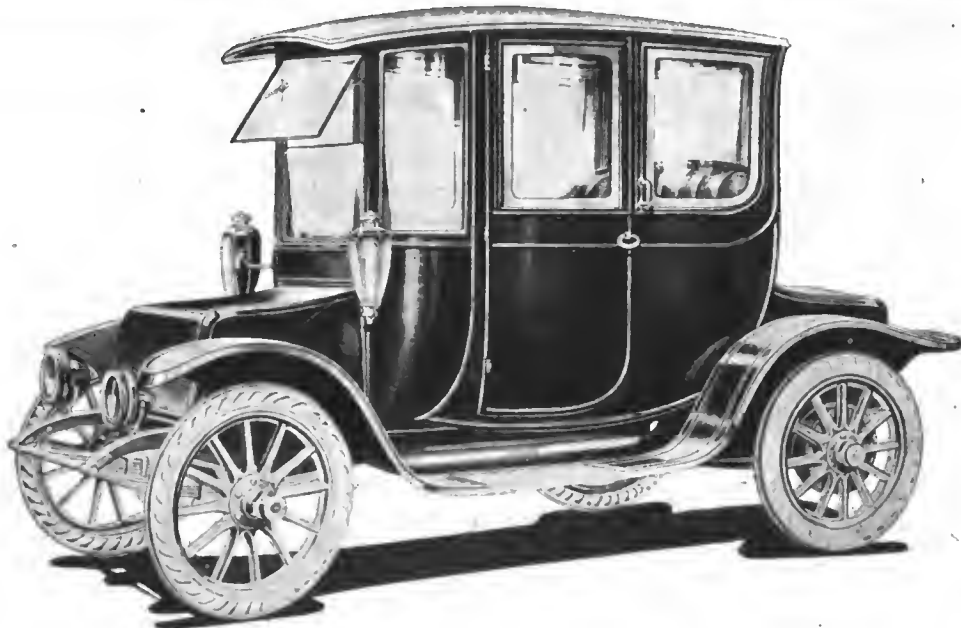

**W**HEREVER you may be located, Mr. Dealer, the Detroit Electric will make good. This is the car that is so popular in such hilly cities as Kansas and Seattle. Whatever the conditions in your city, you can recommend this car with absolute assurance that it will satisfy your customers and sell more cars for you.

The Detroit Electric has many exclusive and patented features that cannot be obtained elsewhere, but, what is more to the point, they are features that the public is fast learning to appreciate and are going to demand in an electric vehicle more and more. For instance, those who really know about electric cars are insisting upon a real Shaft Driven car. They will not be satisfied with merely a Shaft Drive with concealed chains at the motor. They want the "Shaft-Drive" "Chainless." Please note the word "Chainless." It means the entire absence of chains or gear reductions at the motor. You cannot obtain this drive except in a Detroit Electric.

The reason we have produced an exclusive Shaft Drive is because of the original type of motor we have developed to meet the peculiar requirements of an electric car. We do not use "stock" motors because they are not speeded and designed to fit the conditions surrounding the electric pleasure car. There are a dozen other features that you should know about that space does not permit mentioning.

*THE*  
*Detroit*  
ELECTRIC  
*Shaft Drive*  
*Chainless*

Our new catalog, which, by the way, you must see to appreciate, will give you a better idea of this remarkable car. We will gladly send it on request.

We will exhibit at Madison Square Garden Jan. 7th to 13th, Chicago Feb. 2d to 9th.

**ANDERSON ELECTRIC CAR COMPANY**

**416 CLAY AVENUE, DETROIT, MICH.**

Branches: New York, Broadway at 80th St. Brooklyn, Cleveland, Minneapolis,  
Chicago, 2416 Michigan Avenue, Buffalo, Kansas City, St. Louis.

*Selling representatives in all leading cities*

1912

## New Year's Eve.

Ring out, wild bells, to the wild sky,  
The flying cloud, the frosty night;  
The year is dying in the night;  
Ring out, wild bells, and let him die

Ring out the old, ring in the new;  
Ring, happy bells, across the snow;  
The year is going, let him go;  
Ring out the false, ring in the true.

Tennyson

## A Card

## In re Vanderbilt Race

and

## F &amp; S Ball Bearings

A man hath joy by the answer of his mouth: and a word  
spoken in due season, how good is it!—*Proverbs xv: 23.*

For over fifteen years the world-renowned house of Fichtel & Sachs, of Schweinfurt, a/M., Germany, the makers of the famous F. & S. Ball Bearings, by virtue of their fundamental patents in all countries, their own inventions, and those acquired from other original sources, have occupied the premier position in the ball bearing industry. This supremacy has been unquestioned because of not only the high quality, but also because of their quantity production of fifteen thousand complete ball bearings daily for various purposes, besides which, their allied ball making plant produces millions of chrome steel balls daily, the two plants employing over thirty-five hundred work-people.

Meanwhile the J. S. Bretz Company, their sole American Representatives, have not been unmindful of the high standing and dignity of the great German concern, and in all their ball bearing literature, advertising, publicity and selling campaigns have adhered strictly to ideal, high-minded, safe and sane methods of doing business. That this course was founded on correct principles is evidenced by the constant growth and volume of our business, the mechanical popularity of the bearing, and our financial success and prosperity from a humble beginning.

A self-appointed public censor of our advertising has in his own heterophemistic way raised a tempest in a teapot over the ball bearings used in the four placed cars in the Vanderbilt Race.

It was Webster who said: "Never mind, your honor, what the plaintiff claims; what say this array of competent witnesses?" Webster's logic applies admirably well to this controversy, doesn't it?

One of the earliest and largest American users of F. & S. Ball Bearings was and is the Lozier Motor Car Company. Almost every notable competitive event won by them, such as road races, hill climbs, gasoline efficiency trials, speedway races, twenty-four hour races, etc., etc., was done on cars equipped with F. & S. Ball Bearings. Naturally enough we rejoiced with them, their agents, and the Lozier car users over these victories. We

Please mention The Automobile when writing to Advertisers

advertised these many wins, sometimes by means of signed testimonials from the Lozier Motor Car Company, the latter of which attributed the success of the Lozier cars in these events to the F. & S. Ball Bearings. It is to be noted that we always do all of this with the different makes of cars who use the F. & S. product, not so much for our own personal profit, but to advertise the users of F. & S. Bearings in particular, and to spread the gospel of anti-friction construction in the conservation of power, by that "efficiency which is the ratio between a standard of performance and the actual performance."

If we were fond of Kipling we might quote—"After me cometh a Builder—Tell him, I too have known!" Here follows the whole bearing story of the Vanderbilt Race:

Copy of telegram to  
LOZIER MOTOR COMPANY,  
Detroit, Michigan.

Dec. 16, 1911.

— raises controversy over our advertisement that F. & S. bearings were used in Lozier Vanderbilt cars—our authority your Mr. Perrin. Kindly wire confirmation stating where our bearings were used, and if other makes, also state what and where. Reply desired by Monday. Yours for fair play.

J. S. BRETZ COMPANY.

Lozier says—"The makers of the F. & S. Bearings are, therefore, correct in stating their bearings were used in this car."

LOZIER MOTOR COMPANY  
DETROIT, MICH.

Manufacturing Dept.,  
J. S. BRETZ COMPANY,  
Times Building, New York, N. Y.

December 16, 1911.

BEARINGS USED IN RACER..

GENTLEMEN—In answer to your telegram relative to the bearings used in car which won the Vanderbilt Cup Race, would

# A Card

## In re Vanderbilt Race

and

## F & S Ball Bearings

(Continued)

state that this car was fitted with ——— bearings throughout the entire engine, and also throughout the transmission, with the exception that one small F. & S. bearing was used in transmission on account of its narrow width, and a couple of thrust bearings of the F. & S. make were also used.

The rear axle, however, was fitted with the F. & S. Bearings. This is in accordance with statement I have made both to the ——— and F. & S. people. The makers of the F. & S. Bearings are, therefore, correct in stating that their bearings were used in this car as long as they do not state they were used exclusively. This car happened to have been assembled before we began receiving axles made at our Plattsburgh plant, which axles are fitted with ——— bearings.

JGP D  
Copy to ——— Mfg. Co.

Yours truly,  
(Signed) J. G. PERRIN,  
Ch. Engineer.

### De Palma's Mercedes had F. & S. Bearings

The famous Mercedes cars, which set the fashion to the world in more ways than one, largely use F. & S. Bearings. Manager J. A. Carples, of the Daimler Import Company, says their Chief Engineer told him recently in Germany that F. & S. Bearings were a standard stock equipment on Mercedes cars—both racing and touring.

Ralph De Palma, the metropolitan favorite who drove the Mercedes which finished second, when asked the question which bearings his car had in it, said, "I drove this great car just as I received it from Germany, and if it had any other bearings in it than F. & S., they were placed in it in Germany, and I invite you to inspect it yourselves. The seals on the hub caps are still unbroken, and I have this to say regarding a change of construction in any car I drive: I consider the master mind who designed these racing cars knows what is best to use, and in view of my public announcement of this idea, no one has ever approached me with a view of making a change."

An examination of the De Palma Mercedes car revealed the fact that this car was equipped with F. & S. bearings, and absolutely so in the wheels, which bearings were in dispute.

Regarding the Mercedes which finished third in the race, which was driven by that dashing young American driver, Spencer Wishart, we have this to say: Although the majority of the bearings used in the car are now of another make, still some F. & S. bearings were used, but not enough to emphasize their use—all of which leads up to the variation in the practice of compound use of ball bearings in cars, and hence the use of ball bearings is sometimes as Herbert Spencer once said, "A combination of heterogeneous changes, simultaneous and successive, in correspondence with external coexistences and sequences."

The F. & S. bearing De Palma Mercedes finished second in both the Vanderbilt and Grand Prix races, and is ready with-

out repairs for another race to-day, while the Wishart Mercedes did not finish in the Grand Prix, and lies dismantled to-day.

And so in summing up the result of the Mercedes ball bearing claims, one is reminded of the following squib: "Faith," said the policeman, examining the broken window, "this is more sayrious thin Oi thought it was! It's broke on both sides!"

### A Disclaimer

The following letter from Mr. A. L. Riker, Vice-President and Chief Engineer of the Locomobile Company of America, in reply to a letter of ours asking for information as to what bearings were used in Robertson's Locomobile in the 1908 Vanderbilt Race, prompts us to cheerfully enter a disclaimer here as to the use of our bearings in that car. The statement, however, having been originally made in the hurry of preparing copy for an ad, the writer having in mind at the time the fact that the Locomobile Company, since that time, have been continuous users of F. & S. Bearings.

#### THE LOCOMOBILE COMPANY OF AMERICA ENGINEERING DEPARTMENT

J. S. BRETZ COMPANY, BRIDGEPORT, CONN., Dec. 21, 1911.  
New York City.

GENTLEMEN—I have your favor of the 20th instant and note contents of same. I would state that the make and type of the anti-friction bearing used in Robertson's winning Locomobile in the 1908 Vanderbilt Cup Race, were the ——— annular ball bearings. These ball bearings we used in the wheels, jack shaft bearings and transmission. They also were the American made ball bearings, as they were the same as we used in the Vanderbilt Cup Race of 1906.

Yours very truly,  
(Signed) A. L. RIKER,  
Vice-President.

This closes this discussion in the trade press as to the results of the bearings used in the Vanderbilt Race as far as we are concerned, our time and thoughts being turned towards the coming New Year, the Shows and other events, and in conclusion, we wish that "Content be ever yours—good health, prosperity, and thought for us who ever seek to serve."

**J. S. BRETZ COMPANY**  
SOLE IMPORTERS  
**F & S**  
**Ball Bearings**  
250 West Fifty-fourth, New York

Please mention The Automobile when writing to Advertisers



## The Lesson of the Year

**A** NOTHER year has completed its cycle—the richest in experience with motor trucks that the world has ever known. And now, already the epoch-making “shows” are again claiming the attention of the whole automobile world, trying to visualize the progress which the twelve months have made. This experience and progress must have their lessons for every business which has deliveries to make. Perhaps the most important lesson is the fact that so many hundreds of businesses have found—not that they could use the motor truck—that was always true—but that it means so much to their business in increased service, in increased business, in general effectiveness all along the line. In showing business men this pleasant solution of their delivery problems, no truck has been more prominent or taken a bigger share of the burden than the White.

## The Simplest Truck—The White

Great as has been the progress of motor trucking during the last year, numerous as have been the new fields tapped by this new method of transportation, motor trucking possibilities are just beginning to be understood, and with each succeeding day the field grows wider and wider until there seems to be no reasonable limit to the houses that can profitably use motor trucks. In this ever widening field, one truck must always hold its own, always be one of the first to be considered. That one is the White, because of the peculiar simplicity of its engine design—of ease and operating its engine and the making of any adjustments which may ever be necessary. Any engine built to-day would pattern after the White because the designer would want to get all the power possible with the smallest charge of gasoline—in other words, power in its most economical form—which means the long-stroke engine. The long-stroke engine, with its cylinders cast en bloc, is the simplest form of high-power motor, allowing an almost complete elimination of the usual paraphernalia that litter the average engine. The White engine is easy to care for and operate, is attractive to the driver, consequently does not discourage him to neglect his work; and this is half the battle. A truck engine with complicated mechanism that takes hours to unravel does not invite a tired driver to investigate the cause of some minor trouble which may very quickly become a major trouble if neglected. Further, the White Trucks are built in such capacities as to take care of all your business, being made in fifteen-hundred-pound delivery wagons, ton-and-a-half, three- and five-ton trucks, with standardized type of engine in all.

Why not submit your delivery problem to us? Let us suggest the size and type of trucks you need. If interested we have testimonials of many in your line of business, which tell you better than we can what you can do with the White truck.

  
**The White Company**

800 EAST 79th STREET, CLEVELAND, OHIO

# CHICAGO

Chicago is the first city to officially recognize the need of a more efficient warning signal than the bulb-horn.

The following ordinance was enacted by the Chicago City Council on December 4 1911:

*“Every motor vehicle or motor cycle while being used upon the streets, alleys and public places of this city shall be provided with a suitable bell, horn or other signal device; and it shall be unlawful for any person to use any device which will not produce an abrupt sound, sufficiently loud to serve as an adequate warning of danger; and it shall be unlawful for any person operating any motor vehicle or motor cycle to make or cause to be made an unnecessary noise with any such bell, horn or other signal device, or to use the same except as a warning of danger.”*

The time is near when similar action will be taken by other cities.

The safety of the streets demands such action.

The bulb-horn is universally recognized as inefficient, unreliable, unsafe. The

trend of public opinion is against its use.

The makers of seventeen motor cars have foreseen this trend and are regularly equipping with the Klaxon—approved by the public and the law, and used by more than 70,000 motorists.

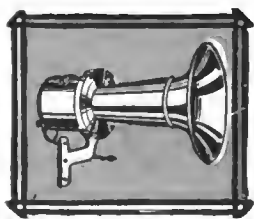

KLAXONET

LOVELL-McCONNELL MFG. CO., Newark, N. J.

## KLAXON

*The Public Safety Signal*

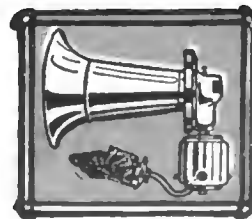

KLAXON

Please mention The Automobile when writing to Advertisers



# Greatest Safety Device Ever Invented For The Automobile

## The B & L Caster Front Axle

SAFE DRIVING

EASY STEERING

PERFECT CONTROL

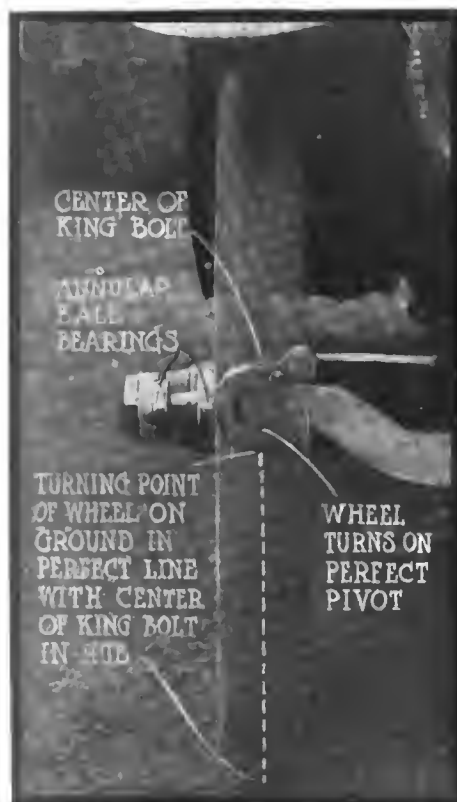

*B & L Caster Front Axle*

The advantages of caster steering can easily be seen by contrasting the illustration on the left with the illustration on the right.

Note how the turning point of The B & L Caster Axle is placed absolutely in the center of the wheel hub. This makes a perfect pivot because the turning point of the wheel on the ground is in perfect line with the center of the king bolt in the hub.

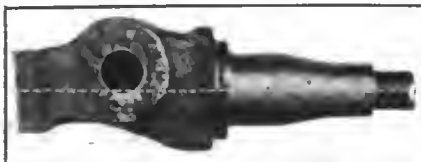

King bolt or turning pin located 3/8 of an inch forward of the center of spindle so as to cause a perfect caster or eccentric front wheel.

In an ordinary axle the center of the king bolt is 3 1/2 inches outside of the hub and the wheel does not turn on a perfect pivot. The strain on the wheel makes it hard to steer and is often the cause of broken knuckles, which result in serious accidents and loss of life.

A broken knuckle is an impossibility with The B & L Caster Front Axle—strain enough to break it would break the axle itself first.

The Benz, Palmer Singer, Simplex, and many other leading cars use the same kind of knuckle we do, EXCEPT our knuckle is enclosed in the hub.



*An Ordinary Axle*

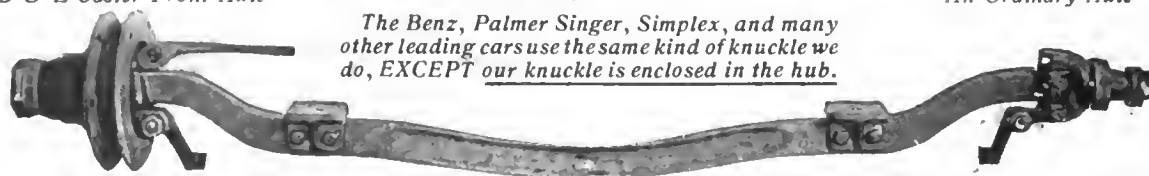

When The B & L Caster Front Axle is used the front wheels travel absolutely in the same direction that the back wheels push unless turned purposely by the driver. Steering is so easy as a result of this construction that the steering wheel can be turned with the little finger, and even if the hands are removed altogether the car will continue in a straight course, regardless of road conditions.

**Equip your car with The B & L Caster Front Axle and it will possess the following advantages:**

Will steer 85% easier—you'll have 90% better control—neither knuckle nor spindle can be broken—car can be turned around in one-quarter less space—front wheels will turn on perfect pivot—control just as easy in sandy or muddy roads as on smooth highway—steering mechanism can become disconnected and car will continue in a straight course, thus allowing plenty of time to stop before an accident occurs—tie rod can be removed, leaving one wheel free, and with control of other wheel car can be guided in any direc-

tion—vibration of steering wheel will be eliminated—wheels will roll into and over holes without sidethrust—75% of skidding will be prevented—weight of car will be located on the knuckle instead of being distributed over an outer point of suspension—friction and strain on tires when turning will be eliminated on account of wheels being set perpendicular—bearings will last twice as long because the caster construction eliminates side thrust—you'll enjoy safety in driving you never experienced before.

Let us send you names of manufacturers who will, when requested, equip cars with this axle, which insures Safe Driving, Easy Steering and Perfect Control.

A. S. Burnell, President and General Manager  
QUEEN MANUFACTURING CO., Chicago Branch, 1346 Michigan Ave.

Please mention The Automobile when writing to Advertisers

# NEW DEPARTURE BALL BEARINGS.

**Double Row**  
Combined Radial  
and Thrust

**Single Row**  
Strictly Radial

**Radax**  
Radial and Axial

**S**TEADILY increasing use of New Departure Ball Bearings proves that this strictly American product is equal to the foreign in all respects. New Departure quality is due to

Guaranteed Materials  
Guaranteed Workmanship  
Guaranteed Finish  
Advanced Manufacturing Processes  
Supervision of every detail of Production by expert engineers.

Gauging for precision of measurement at every stage of manufacture.

Final inspection which rejects all bearings not true within extremely close limits.

We can give you bearings specially adapted for any place where the use of ball bearings is practical and can satisfy you on *prompt deliveries.*

**The  
New Departure  
Mfg. Co.**

**Bristol, Conn.**

Western Branch:  
1016-17 Ford Bldg., Detroit

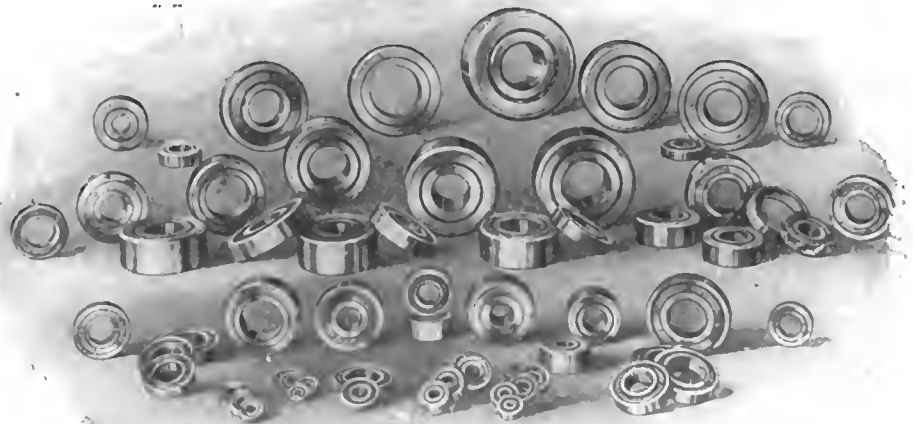

# PRESSED STEEL FRAMES

**FOR TRUCKS AND PLEASURE CARS**



**27TH STREET PLANT**

**We Make 60% of All the Pressed Steel Frames  
Used In this Country**

**LET US FIGURE ON YOUR REQUIREMENTS**

—EXHIBIT—

**New York, Madison Sq. Garden**

**JAN. 6-13, 1912**

—EXHIBIT—

**At Chicago, Coliseum**

**JAN. 27-FEB. 3, 1912**

---

# **A. O. SMITH COMPANY**

**MILWAUKEE**

Please mention *The Automobile* when writing to Advertisers



*Elmore*

Five-Passenger Light Torpedo, \$1250

With Top and Windshield, \$1350

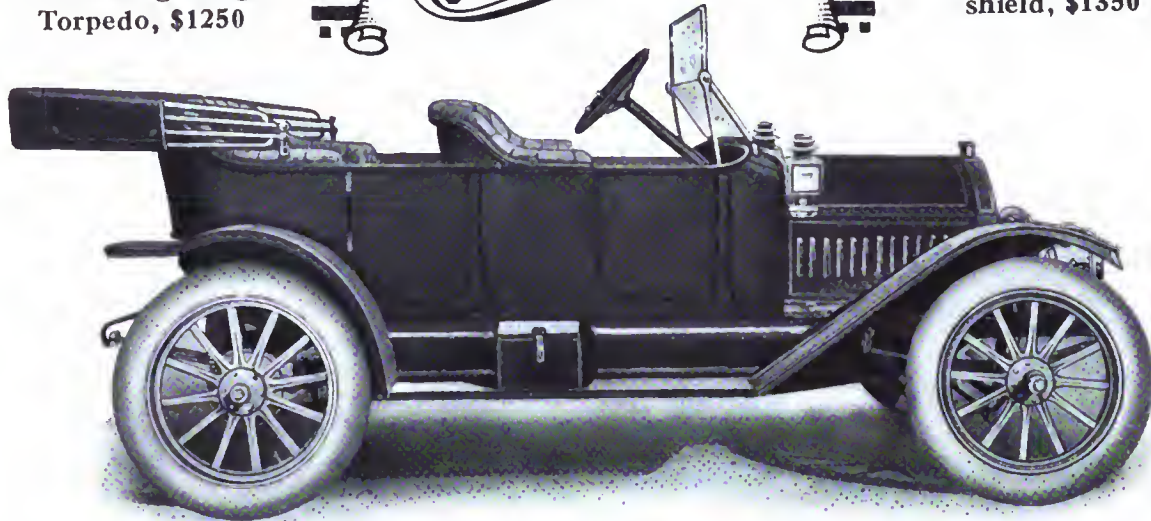

## The One Proven Successful Valveless Motor

Everybody, nowadays, has come to realize the simplicity and super-efficiency of the valveless construction. The whole automobile world is ringing with extravagant claims and arguments for the valveless motors now so widely exploited.

**BUT REMEMBER THIS.** Every such claim put forth applies with doubled force to the Elmore valveless motor—which, in a dozen years of successful service, has in the hands of owners throughout the country proved both its simplicity and its superiority. We passed the experimental stage years ago.

And the Elmore does not cost \$3,000, \$4,000, \$5,000. There is a model to fit every motoring need, at a price well within the purchasing power of the most conservative.

### The Elmore was the Pioneer in Valveless

#### Engine Construction

We have advocated the valveless engine since the inception of the automobile industry in America. The first valveless two-cycle Elmore engine that was installed in a motor-car was a success—a great success. And each year we have refined and simplified it until, in this year's models, we are installing a motor that we believe to be as perfect as human ingenuity can make it. We ask you to prove for yourself that it is the simplest, most efficient automobile engine extant.

In buying an Elmore you are not buying an experiment or a novelty, but a motor tested by thousands of owners for over a dozen years—a motor which, by virtue of patent rights, no other motor-car can have.

### Elmore Construction is of the Best

There could be no better built car than the Elmore. Skilled workmanship and careful supervision accompany every detail. We aim to make the car itself a worthy setting for the gem of a motor that runs it.

Whether your need be for a roadster or for one of the various types of touring car, you will find an Elmore model which in appearance and in service will rank with any car at any price. And the wonderful, exclusive Elmore motor assures you a smooth, sweet-running car with the utmost in power efficiency, and with an entire absence of valve troubles and valve expense.

### Write for the Elmore Book

We have prepared a very interesting booklet about the Elmore car, which will be sent free on request, together with the name of the nearest dealer where you can see and test this wonderful car for yourself.

## THE ELMORE MANUFACTURING CO., 212 Amanda Street, Clyde, Ohio

**DEALERS:** For 1912 we have doubled our factory capacity, thus enabling us to double our output. We are, therefore, enabled to take on a few additional dealers in sections not yet allotted. Write us for 1912 proposition on the one moderate-priced "car with a reason."



Torpedo Roadster, \$1150, Top and Windshield Extra

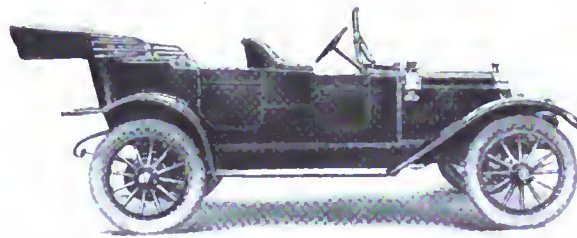

5-Passenger Fore-door Touring Car, \$1600, Top and Windshield Extra

Please mention The Automobile when writing to Advertisers

## GENERAL ELECTRIC COMPANY'S

EDISON  
AUTOMOBILE



MAZDA  
LAMPS

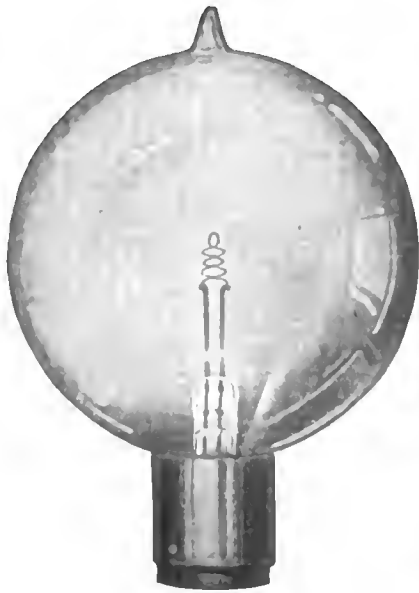

Head



Side



Rear

**A**N Electric Lighting System on the car is evidence of the manufacturer's progressive policy in supplying the demand for a clean, safe, reliable method of lighting.

Electric Lighting needs no attention and any lamp can be operated from the dash.

Edison Mazda Lamps have been carefully designed for automobile service. Note the compact, close-coiled filament of the headlight.

The filaments of Edison Mazda Lamps are made from a drawn wire as strong as piano wire.

Write for Bulletin 4795, which gives some valuable details on automobile lighting. The bulletin tells how simple it is to wire a car for electricity and how existing lamps may be easily converted to electric.

*Write for Bulletin today.*

## General Electric Company

Main Lamp Sales Office, Harrison, N. J. 3193 Principal Office, Schenectady, N. Y.

# MERCER

The Champion  
Light Car

In the production of  
all Mercer models quality  
is the first aim.



Type 35—Series A and B—Five-passenger or four-passenger torpedo bodies—fully equipped—\$2,750.

## NEW MERCER SERIES

In your visit to the Automobile Shows, don't fail to give all Mercer models your most rigid inspection. Compare our new type 35, series A and B, foredoor torpedoes, and our raceabouts and runabouts, with the product of any other maker. We honestly believe you will find it hard to get as good a car, and impossible to get a better, at the same price as our new series.

You will find embodied in all Mercer models every up-to-the-minute, thoroughly tried-out, and really meritorious improvement. You will find a car that is strongly built, has power and speed in abundance, has

grace of line, is luxurious in appointments and has comfortable riding qualities.

We want you to learn for yourself why the Mercer was able to win such strenuous tests as the Savannah Challenge Trophy Race, the Kane County Stock Championship race at Elgin, Ill., and other notable 1911 speed contests. All-round efficiency made possible the winning of these contests. Every Mercer car turned out possesses efficiency equally as great as our raceabout, which has made a creditable clean-up on both track and road. We can and will prove this.

*Send for detailed specifications or see us at the shows*

MERCER AUTOMOBILE CO., 400 Whitehead Road, TRENTON, N. J.

Please mention The Automobile when writing to Advertisers



# Make Your Car a Convenient Car



**Bayonet Socket Cable Coupling** for an electric lighting system. This connector gives close positive contact with absolutely no leakage of current—commendable features where low voltage must of necessity be used. All parts of this coupling are well insulated and in addition to its convenience in making connections the terminals are protected from exposure. The bayonet joint prevents coupling jolting loose.



**Flush Socket and Receptacle Coupling.** A neat combination for soldering to the base of the lamp. Lighting circuit is broken by the coupling, allowing the lamp casing to be removed if necessary. The oil reservoir may still be retained in the lamp if desired, in addition to the Flush Socket.

Cable Coupling



**Flush Socket and Receptacle Plug.** This socket is fitted with a flange similar to the socket above mentioned and can be used in place of it. Instead of a coupling to disconnect or connect circuit, a **Flush Receptacle** and plug is used which can be mounted anywhere on the car. This is an exceptionally useful arrangement for a portable extension light.

Flush Socket and Receptacle Coupling



All sockets are made to fit our sturdy drawn wire Edison Mazda Lamp.

Flush Socket

**Switches.** Four-gang switches for full electric light equipment, designed to withstand all the conditions of automobile service. Three gang switches just as rigidly constructed, for three or five lamp equipment. Flush or surface type switches built to stand the same hard service, also single pole switches, two-gang switches, etc. No splicing or joints in wiring are necessary with these switches, as all connections are made at back of switch by means of bus bars.



Two-gang Flush Tumbler Switch

The installation of these "car comforts and conveniences" cannot fail to impress the prospective purchaser in favor of your car.

# General Electric Company

Principal Office, Schenectady, N. Y.

3303

TWELFTH NATIONAL

# AUTOMOBILE SHOW



## MADISON SQUARE GARDEN

**PART I**  
**JANUARY 6-13**

**PLEASURE VEHICLES—Gasoline and Electric—Motorcycles—Parts—Accessories**

The Following Cars Will Be Exhibited:

- |           |          |             |               |                |                   |
|-----------|----------|-------------|---------------|----------------|-------------------|
| Aico      | Columbia | Inter-State | Mitchell      | Pope-Hartford  | Stoddard-Dayton   |
| American  | Corbin   | Jackson     | Moline        | Premier        | Thomas            |
| Amplex    | Courier  | Knox        | Moon          | Pullman        | White             |
| Atlas     | Elmore   | Locomobile  | National      | Peerless       | Winton            |
| Brush     | E-M-F    | Lozier      | Oakland       | Reo            | (Electric)        |
| Buick     | Everitt  | McIntyre    | Ohio          | Selden         |                   |
| Cadillac  | Flanders | Marmon      | Oldsmobile    | S. G. V.       |                   |
| Cartercar | Franklin | Marquette   | Overland      | Simplex        | Detroit           |
| Case      | Garford  | Matheson    | Packard       | Stearns        | Baker             |
| Chalmers  | Haynes   | Maxwell     | Palmer-Singer | Stevens-Duryea | Flanders Colonial |
|           | Hudson   | Mercer      | Pierce-Arrow  |                | Waverley          |

**PART II**  
**JANUARY 15-20**

**COMMERCIAL VEHICLES—Gasoline and Electric—Parts—Accessories**

The Following Cars Will Be Exhibited:

- |           |            |               |           |            |
|-----------|------------|---------------|-----------|------------|
| Aico      | Grabowsky  | Morgan        | Reo       | (Electric) |
| Autocar   | Hewitt     | Packard       | Sampson   | Baker      |
| Brush     | Knox       | Peerless      | Saurer    | Bronx      |
| Buick     | Locomobile | Pierce-Arrow  | Speedwell | Detroit    |
| Cartercar | Lozier     | Pope-Hartford | Stearns   | G. V.      |
| Garford   | McIntyre   | Rapid         | White     | Studebaker |
|           | Mack       | Reliance      |           | Ward       |

Management: SHOW COMMITTEE, 7 East 42d Street, New York

# The Atwater Kent Ignition System

## Primary or Secondary Equipment

**O**WNERS of cars equipped with both magneto and Atwater Kent systems frequently discard the former and use the latter as sole equipment

Owners who begin with the Atwater Kent System never add another. They can imagine nothing more dependable—and they are right.

No source of current is so reliable as a battery. Add the positive, mechanically-driven make and break of the Atwater Kent contact maker, the large, carefully-built A. K. spark coil and the well-insulated A. K. distributor—and you have a combination of elements impossible to surpass for sheer clock-like regularity of action. Yet its very simplicity enables it to be sold at a moderate price.

Use the Atwater-Kent Spark Generator or UNISPARKER as you like—with dry or storage battery, or with a dynamo lighting system. Use it as primary or secondary equipment; it will never play tricks.

Applicable at small cost to most new or old cars.

Booklet gives full technical description. ■

**ATWATER KENT MFG. WORKS**

42-50 NORTH SIXTH STREET  
PHILADELPHIA, PA.



F. C. Millhoff

E. C. Gammet

**THE M & M MANUFACTURING CO.**  
Manufacturers of Vulcanizing Solution

Akron, Ohio, July 18th, 1910  
Atwater Kent Manufacturing Works,  
Philadelphia, Pa.

Gentlemen:—

*I received the new Unisparker and can say it is certainly giving satisfaction: in fact, I would sooner run on the Unisparker than on the magneto. I think that this is the best system yet, will always believe so providing the Unisparker works as well as it does now.*

Yours very truly  
(signed) F. C. Millhoff.

\* PENNSYLVANIA \* TEXAS \* CALIFORNIA \* ILLINOIS \* WASHINGTON \* \* \*



# The Only Complete Car

**Mr. Dealer:**  
Don't You Want to make these sales?

Buyers will want the Inter-State—the only complete car ever produced! The car that in itself performs all the labor of Electric Self-Starting, Electric Lighting and Ignition; Tire Pumping; and the Automatic regulation of Fuel Consumption.

The Labor-Saving Self-Controlled



King of all Cars for 1912

**Electric Starter** Starts the motor without "40" and "50" Models cranking, without danger, without touching the clutch pedal, without engaging any gears, without releasing a pedal after motor starts. Just push the switch when you are ready to start—nothing more. It's as easy as striking a match.

**Electric Lights** Consist of two powerful head "40" and "50" Models lamps with the improved dimming feature. Two dash lamps and a tail lamp. Also the small lamps for illumination of speedometer and clock dials. All or any combination of lights can be turned on by simply turning the switch. Always ready—no tanks or generators to look after and renew.

**Automatic Carburetor** Entirely regulated "40" and "50" Models from the steering post. A simple movement of the lever by your finger gives all the regulation required for economy of fuel and increased power. Perfect results to novice and expert.

**Long Stroke Motor** 4 cylinder type is a triumph of engine making. "40" and "50" Models Made and tested out entirely in the great Inter-State factory. By an ingenious construction all back pressure is avoided and the power "hangs on" at low speed like an electric motor. Enclosed valves make it almost noiseless.

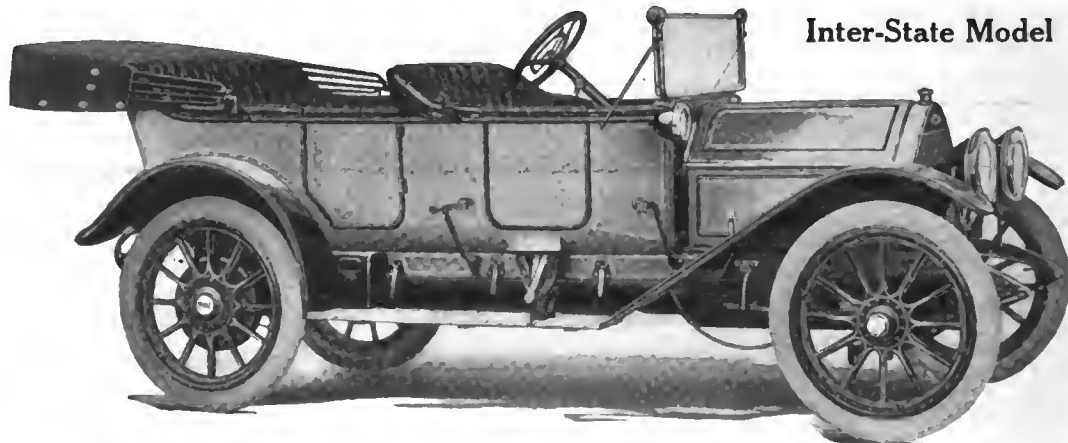

Inter-State Model "40"

Model 40—5 Passenger, Fore Door Touring Car.  
Model 41—4 Passenger Demi Tonneau.  
Model 42—Roadster type—all with the splendid new en bloc motor, 4 1/2" bore, 5 1/2" stroke, developing 5 to 8 H.P. more than rated, 3 speeds forward and one reverse, completely equipped and with all 1912 features here mentioned.

**\$2400**

Model 50—7 Passenger, Fore Door Touring Car.  
Model 51—4 Passenger, Demi Tonneau.  
Model 52—Roadster type—all with the new "T" head 5" bore, 6" stroke motor, developing 8 H.P. more than rated by actual test, 4 speeds forward and one reverse, completely equipped and with all 1912 features here mentioned.

**\$3400**

**The Inter-State "40" and "50" Equipment is Complete** High grade top, slip cover, automatic windshield with patented ventilating attachment, a wonderful pair of search head lights; electric side lights; combination tail light; heavy nickel and enamel finish throughout, dimming device on headlights for use on city streets at night; speedometer, clock and electric light combined; signal horn; air adjustment of fuel mixture on steering column; commodious leather flap pockets on inside of doors; cocoa mat; extra demountable rim, gasoline gauge on dash; power tire pump and complete tool outfit.

**Write, wire or phone (our expense) for agency Inter-State Automobile Company,**

See the INTER-STATE line January 6-13, 1912, at Madison Square Garden Show—Space 50, Exhibition Hall

\* NEW YORK \* MARYLAND \* OHIO \* MICHIGAN \* FLORIDA \* MAINE \* \* \*



Please mention The Automobile when writing to Advertisers

★ ★ ★ MASSACHUSETTS ★ IOWA ★ WISCONSIN ★ VIRGINIA ★ MISSOURI ★



# Distinctive Inter-State Features

## You Cannot Find All These Features in Any Other Make of Car

All "40" and "50" Models have every feature here mentioned.

**Long Stroke Motors**—4½ inches x 5½ inches in "40's," 5 inches x 6 inches in "50" Models. Noiseless—No back pressure.

**Large Wheels and Tires**—36 inches x 4 inches in "40's," 36 inches x 4½ inches in "50" Models.

**Demountable Rims**—(Set of Five.)

**Power Tire Inflator**—Instantly available and worked from motor power. Tire pumping labor eliminated.

**Multiple Disc Clutch**—Steel and Bronze, 10 inch Discs, with Cork Insert Contact.

**Imported Annular Ball Bearings**—Used wherever required.

**Long Wheel Base**—118 inches in all "40's," 124 inches in all "50" Models.

**Complete Electric Light System.**

**Automatic Regulation of Fuel Consumption**—Effected by a wonderful New Carburetor, economizing and gaining added power to the motor.

**Housed Valves and Valve Springs**—Insuring Quiet Operation and Cleanliness.

**Dropped Frame Construction**—Narrowed for short turning, the Drop allowing the low, straight line effect and giving great stability to car.

**Gasoline Gauge on Dash**—Showing at a glance the supply and rate of consumption of fuel.

**Mr. Buyer:** The Inter-State "40's" and "50's" are the long looked for perfect cars. The first models have created a sensation. If you have owned a car you will realize what a wonderful innovation the Inter-State is. If you are buying your first car, you will want no other than the perfect, self-acting Inter-State, which has robbed motoring of all disagreeable features.



These powerful, luxurious "40" and "50" Inter-State cars can be enjoyed by the whole family and can be handled by a woman with the same ease and safety, with which she controls an electric coupe. The Inter-State is designed, built and equipped for absolute pleasure and service. Nothing has been left out. You will have to make no further outlay for accessories. Future years may produce its equal, but for 1912 the Inter-State is KING. The Inter-State is the car of supreme quality and beauty, built from the ground up in the great Inter-State factory.

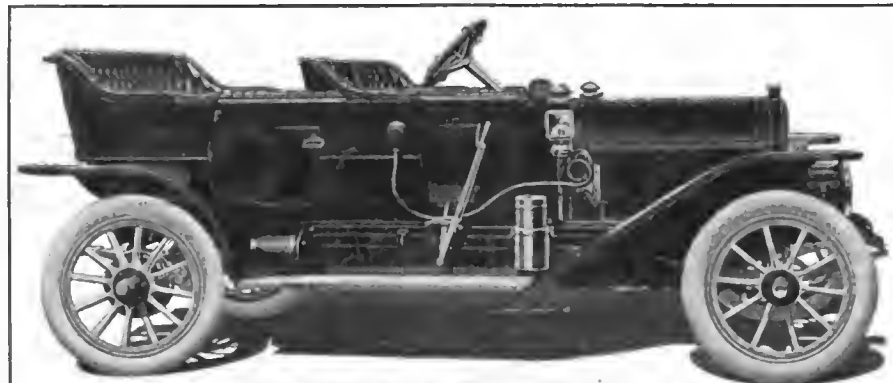

Inter-State Model "30-A" Fore Door

We offer two lower priced cars of Inter-State quality:  
Model 30-A—Fore Door, 5 Passenger Touring Car, \$1750  
Model 32-A—Roadster - - - - - \$1700

These cars are equipped with 40 H.P. 4-cylinder L-Head long stroke motor; High tension imported magneto, storage battery and timer; multiple disc cork insert completely housed clutch; Sliding gear selective type transmission, three speeds forward and one reverse. All construction being of highest grade of workmanship and of latest improved design. Equipment consists of two gas headlights with generator, side and tail oil lamps, nickeled bulb horn and tools; combination tool and battery box; robe and foot rail. Nickel plated metal trimmings throughout.

In addition to the equipment mentioned and at a small additional cost, these two models will be fitted with Top, Automatic Windshield, Speedometer and the Preato Self-Starter.



## Catalogue

Dealers and buyers ought to have this book. The entire Inter-State line is beautifully illustrated, and specifications and features are minutely described. It gives the best idea possible of the Inter-State, with the exception of examining the car itself.

Send your name for a free copy and be sure to see these wonderful models of 1912 Inter-State cars.

See the INTER-STATE line January 26th-February 3rd, 1912, at Chicago—Space A-4 First Regiment Armory

**Dept. A, Muncie, Indiana, U. S. A.**

BOSTON BRANCH: 153 Massachusetts Ave.

OMAHA BRANCH: 310 S. Eighteenth St.



★ ★ ★ COLORADO ★ INDIANA ★ ALABAMA ★ KANSAS ★ MINNESOTA ★

Please mention The Automobile when writing to Advertisers





# THE National Automobile Shows of 1912

Under Auspices of National Association of Automobile Manufacturers, Inc.

## NEW YORK

**Grand Central Palace--January 10-17**

A Complete Display of Passenger and Commercial Vehicles, Parts and Accessories

## CHICAGO

**Coliseum and 1st Regiment Armory**

**January 27 to February 3**

**February 5 to 10**

Passenger Vehicles, Parts and Accessories.

Commercial Vehicles, Motorcycles, Parts and Accessories.

The Entire Trade in One Comprehensive Exhibition

**S. A. MILES, Manager**

**7 East 42nd Street, New York**

# A Hot, Fat Spark to the Centre

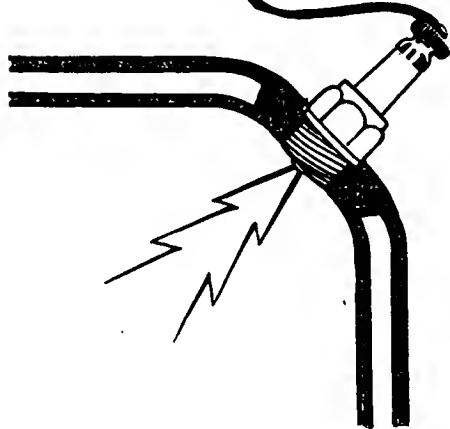

Using a separate contact breaker for both battery and magneto—equipped with the very latest Eisemann pole pieces—carrying our most advanced type of breaker boxes—perfectly accessible in all its parts—using nothing but the finest India amber mica as the insulating medium in the condenser; the “type E. M.” Eisemann high tension dual ignition system is unquestionably the greatest dollar for dollar ignition system on the market. It possesses all of

the exclusive points of Eisemann excellence both as to material used and manufacturing methods employed, and yet is sold at comparatively a low price.

This type E.M. dual ignition magneto consists of the E.M. direct high-tension magneto and a spark coil and switch. The coil is used only in connection with the battery. In this system great care has been taken to use only such parts in common for both battery and magneto as are not subject to accident or wear.

The vulnerable parts, such as the circuit boxes, as mentioned above, are applied individually for each circuit. Particular attention is called to the breaker box details as illustrated in the accompanying cut. Instead of using long steel pieces riveted onto the sides of the breaker box as the contact cams for making and breaking the circuit, it will be noticed that the Eisemann cams are large, round, steel pins. The use of this shape cam, rather than the other types, provides absolute accuracy in the correct making and breaking of the circuit exactly on 180 degrees revolution. This is true because the cam is in contact with the circuit breaking lever the smallest possible length of time and at the very smallest possible point.

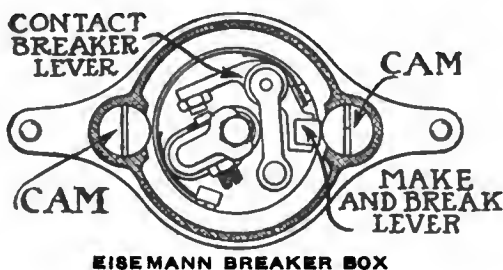

Inasmuch as the fibre piece on the breaker lever is in contact with this cam for the shortest possible time and in the smallest possible measure, there is much less wear and tear on both parts than if the circuit breaking lever were rolling over the long cam for a considerable space of time. The entire breaker box is very strong and sturdy and as near fool-proof as is possible to be constructed.

In order to provide lubrication for the fibre piece on the contact lever, a small oil wick is placed in a slot in the bottom of the circuit breaker, one end of which is in contact with the oil, which seeps out of the ball bearings. Once every revolution of the armature the contact lever laps over this small

wick, thereby being both lubricated and cleaned.

The E.M. magneto may be entirely overlooked by the most inexperienced person in not over a minute as every part is accessible.

Both breakers may be inspected while the magneto is in operation.



## THE EISEMANN MAGNETO CO.

225-227 WEST 57th ST., NEW YORK

527-528 FORD BUILDING, DETROIT, MICH.

**100 miles  
for 39¢**

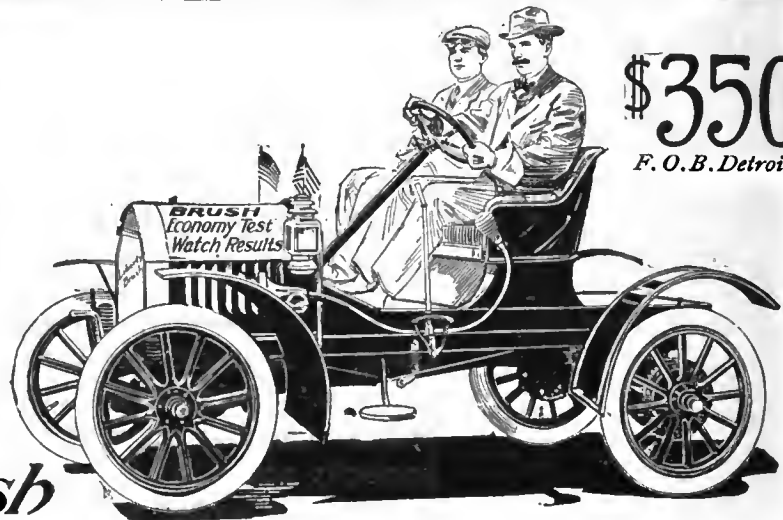

in this

*Liberty-Brush*

**This is cheaper transportation  
than horse, trolley or train**

ONE Brush car covered 100 miles at a cost of 39 cents in an economy contest. 108 other cars competed and the average cost was only 65 <sup>9</sup>/<sub>10</sub> cents for the distance. These cars ran in 109 different cities—so they covered all sorts of roads under all sorts of conditions. 98 cars ran the distance for less than one dollar—less than one cent a mile. One car ran 48.4 miles on a gallon of gasoline. Two others did more than 40 miles—a dozen made over 30 miles. One ran 100 miles on a gill of oil—or 3200 on a gallon.

The poorest record was phenomenally good—100 miles for \$1.30. No other known means of transportation is so economical—it is cheaper than a horse, trolley or train. It is swifter than a horse, more reliable than a trolley, more flexible than a train—you're not compelled to go only where steel rails lead. Thousands are using the Liberty-Brush effectively in their business, not only for its economy of time and money, but because it makes more work possible, enables one to earn more money. Write for data how others are using the Brush for pleasure and business.

Come, see the car—ride in it—learn what it can do. You'll wonder how such an automobile can be built for \$350. It couldn't be, except through the United States Motor Company facilities and economies.

**BRUSH RUNABOUT COMPANY** 2 West 61st Street at Broadway New York  
Division of **UNITED STATES MOTOR COMPANY**  
*Free Monthly Inspection of all our Cars for Twelve Months*

**Maxwell WINS**

hardest Glidden Tour on record. Only team with perfect score. Send for books.  
Maxwell-Briscoe Motor Co. 61st St. New York  
Div. of **UNITED STATES MOTOR COMPANY**



*The Sign of  
Good Cars*

*Stoddard-Dayton Saybrook*

Complete in every detail of construction and equipment.  
Catalog and full particulars on request.  
Dayton Motor Car Co. 61st Street and B'way New York  
Div. of **UNITED STATES MOTOR COMPANY**

**Sampson**  
Freight and Delivery Motors

Strong as its name suggests.  
Alden Sampson Manfg. Co. 61st St. New York  
Div. of **UNITED STATES MOTOR COMPANY**

*Columbia*  
with Silent Knight Motor

Catalog and full particulars on request.  
The Columbia Motor Car Co. 61st St. New York  
Div. of **UNITED STATES MOTOR COMPANY**

# IN OCEAN TO OCEAN TOUR

# 12 PREMIER CARS

## ESTABLISHED WORLD'S RECORD

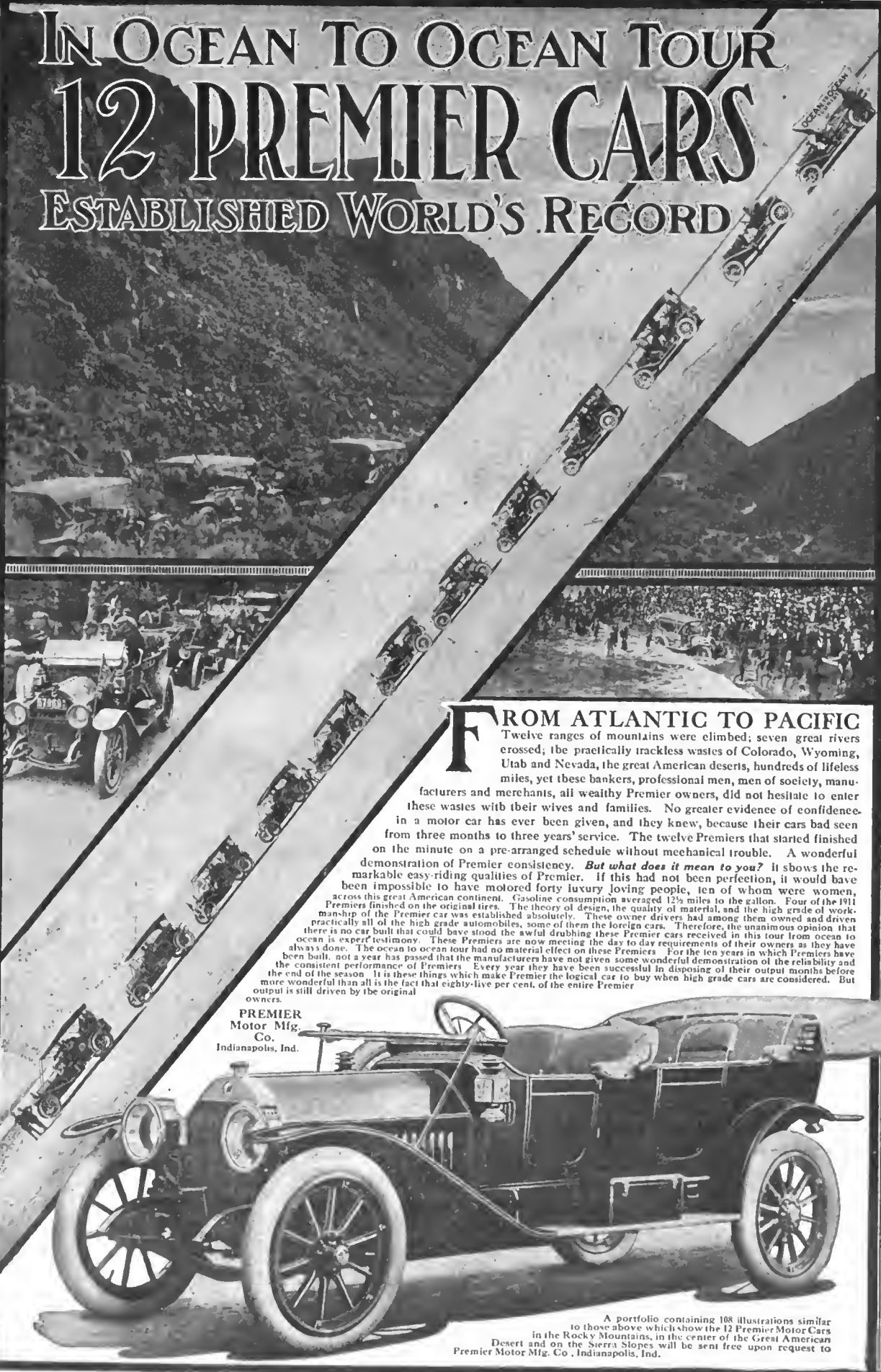

### FROM ATLANTIC TO PACIFIC

Twelve ranges of mountains were climbed; seven great rivers crossed; the practically trackless wastes of Colorado, Wyoming, Utah and Nevada, the great American deserts, hundreds of lifeless miles, yet these bankers, professional men, men of society, manufacturers and merchants, all wealthy Premier owners, did not hesitate to enter these wastes with their wives and families. No greater evidence of confidence in a motor car has ever been given, and they knew, because their cars had seen from three months to three years' service. The twelve Premiers that started finished on the minute on a pre-arranged schedule without mechanical trouble. A wonderful demonstration of Premier consistency. *But what does it mean to you?* It shows the remarkable easy-riding qualities of Premier. If this had not been perfection, it would have been impossible to have motored forty luxury loving people, ten of whom were women, across this great American continent. Gasoline consumption averaged 12½ miles to the gallon. Four of the 1911 Premiers finished on the original tires. The theory of design, the quality of material, and the high grade of workmanship of the Premier car was established absolutely. These owner drivers had among them owned and driven practically all of the high grade automobiles, some of them the foreign cars. Therefore, the unanimous opinion that there is no car built that could have stood the awful drubbing these Premier cars received in this tour from ocean to ocean is expert testimony. These Premiers are now meeting the day to day requirements of their owners as they have always done. The ocean to ocean tour had no material effect on these Premiers. For the ten years in which Premiers have been built, not a year has passed that the manufacturers have not given some wonderful demonstration of the reliability and the consistent performance of Premiers. Every year they have been successful in disposing of their output months before the end of the season. It is these things which make Premier the logical car to buy when high grade cars are considered. But more wonderful than all is the fact that eighty-five per cent. of the entire Premier output is still driven by the original owners.

**PREMIER**  
Motor Mfg.  
Co.  
Indianapolis, Ind.

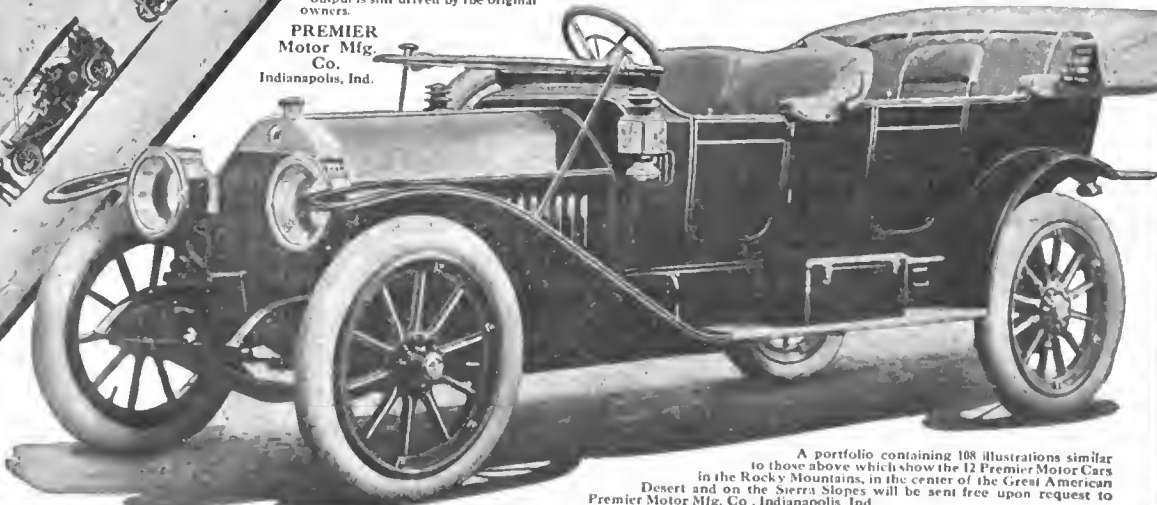

A portfolio containing 108 illustrations similar to those above which show the 12 Premier Motor Cars in the Rocky Mountains, in the center of the Great American Desert and on the Sierra Slopes will be sent free upon request to Premier Motor Mfg. Co., Indianapolis, Ind.

Please mention The Automobile when writing to Advertisers



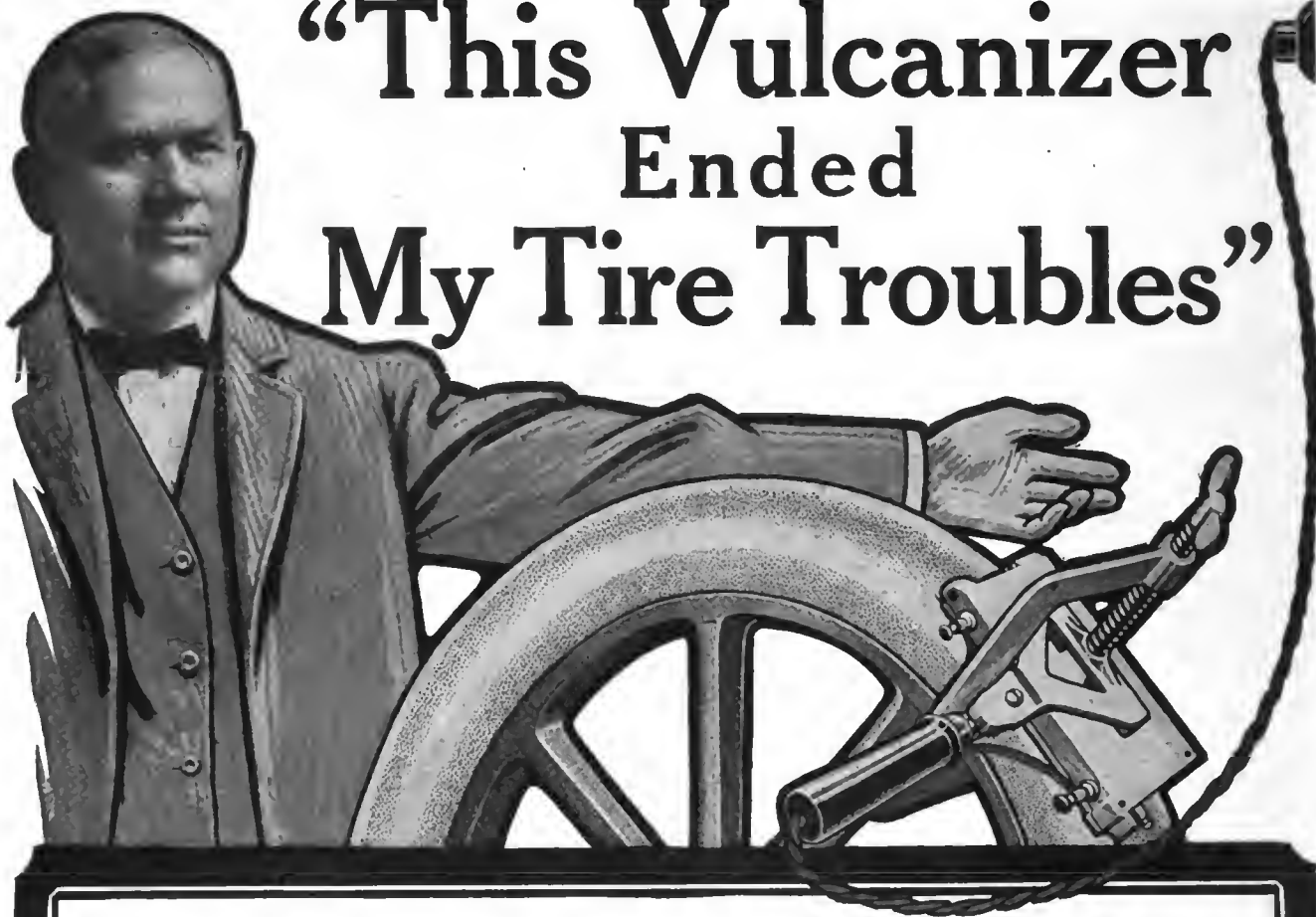

# “This Vulcanizer Ended My Tire Troubles”

Read What O. H. L. Wernicke, “Father of Sectional Bookcases” Says About His

## SHALER VULCANIZER

“The Shaler Vulcanizer I purchased of you *over two years ago is still in constant use*, and I cannot refrain from letting you know that I consider that you have put the automobile world in your debt very greatly.”

“Before I had a vulcanizer I expected tire trouble every time I took my car out. But there is *no longer any danger of accident or inconvenience from blow-outs on the road*. They are a thing of the past. I have done away with them by keeping all stone and glass cuts sealed up, thus preventing rotting and weakening of the fabric, which I find was the cause of 99% of my blow-outs. I do not even carry an extra casing now.

This Shaler Vulcanizer has really ended all my tire troubles. My tires *last three times as long* as they used to, and my tire repair bill is nil. It seems funny

C. A. Shaler Company, 151 4th St., Waupun, Wis. when I realize how skeptical I was about the vulcanizer before you allowed me to try it out. Several of my friends had burned their tires with other portable vulcanizers, and I had little faith. I have since learned that these vulcanizers did not have the Shaler automatic temperature control and overheated the tire unless constantly watched. In conclusion permit me to say that I never purchased an accessory for my car that was as great a trouble eradicator and time saver as my Shaler. *No automobile owner should be without one.*”

Send free copy of “Care and Repair of Tires” and details of ten day trial plan.

My Lighting Current is Direct   
 Alternating  No Current

Name.....

Address.....

If you have ever been up against tire troubles, or feel that your tires are not lasting as long as they should, you owe it to yourself to try this vulcanizer just as Mr. Wernicke did. Write us at once and we will send you the details of this 10 day free trial plan and a free copy of the famous hand book “Care and Repair of Tires,” which contains a remedy for every tire emergency. Use the coupon.

C. A. SHALER CO. 151 4th St. Waupun, Wis.

Please mention The Automobile when writing to Advertisers



# "77" AUSTIN "77"

Some of the Distinctive Features

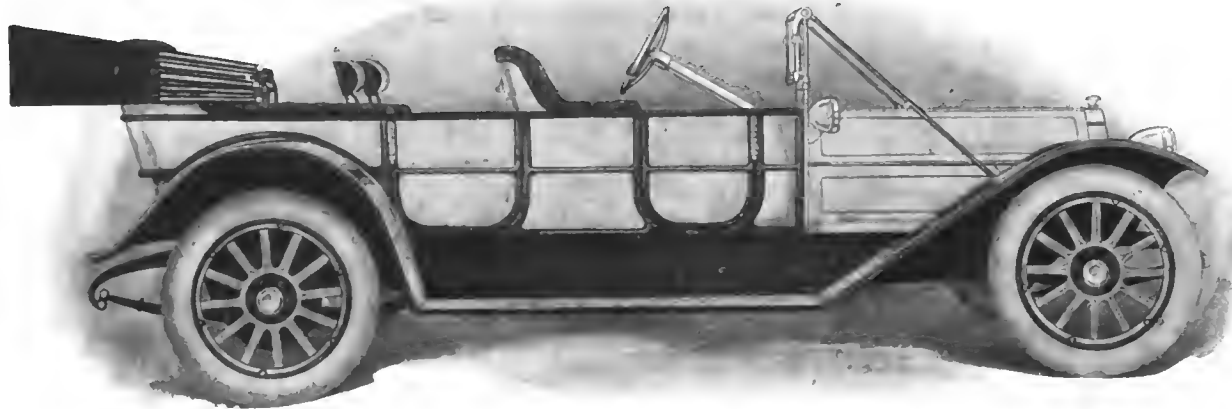

**MOTOR  
SELF STARTER**

Six cylinders. 4½-inch bore, 7-inch stroke.  
High pressure air system, having a special air pump maintaining 150 lbs. pressure in a large tank from which there is also a connection for instantly filling tires with pure air.

**IGNITION**

Two sets of spark plugs, new double combination system, firing each set separate or both sets simultaneously.

**LEFT HAND STEER**

With right hand center control, giving a much quicker view of the road ahead when passing any vehicle, and allowing the use of both front doors.

**TRANSMISSION**

Selective type. Four forward speeds. The center control lever is very short and has a ball and socket joint at the floor connection eliminating all holes or slots in the floor. The segment and also the clutch interlocking device are absolutely positive and are entirely enclosed in the transmission case.

**REAR SPRINGS  
CUSHION SPRINGS**

Three-quarter elliptic, 60 inches long.  
Entirely new double construction. Exceedingly soft and flexible, and still very strong and durable.

**BOTH BRAKES ARE  
CONTROLLED BY  
FOOT PEDALS**

A slight movement of the clutch pedal entirely releases the clutch and at the same time takes up the slack of the emergency brake which is fully engaged by a further movement of the clutch pedal. The service brakes are also operated by a foot pedal. This arrangement eliminates the hand brake lever and enables the operator to handle both clutch and brake with one foot when desired, leaving the other foot free to operate either the exhaust horn or accelerator. Also, both brakes can be applied instantly without taking either hand from the wheel.

**ELECTRIC LIGHTING**

"Leece-Neville" Generator, furnishing 20 amperes at moderate speed. 32 c.p. Head Lights, 16 c.p. Side Lights and 4 c.p. Tail Light. A combination switch controlling all lights as desired, including a dimmer for the head lights. Edison Storage Battery.

**PRICE \$6000.00**

Write for descriptive circular showing many more New, Improved and Special Features.

**MODEL "45"**  
6 Cylinders, 4 3-8 x 5 1-4  
\$3600.00

*Write for our special  
Agency Proposition*

**MODEL "50"**  
6 Cylinders, 4 1-2 x 8  
\$4400.00

**AUSTIN AUTOMOBILE COMPANY**  
GRAND RAPIDS, MICHIGAN

*Ask the man who owns one*

*Packard*  
"SIX"

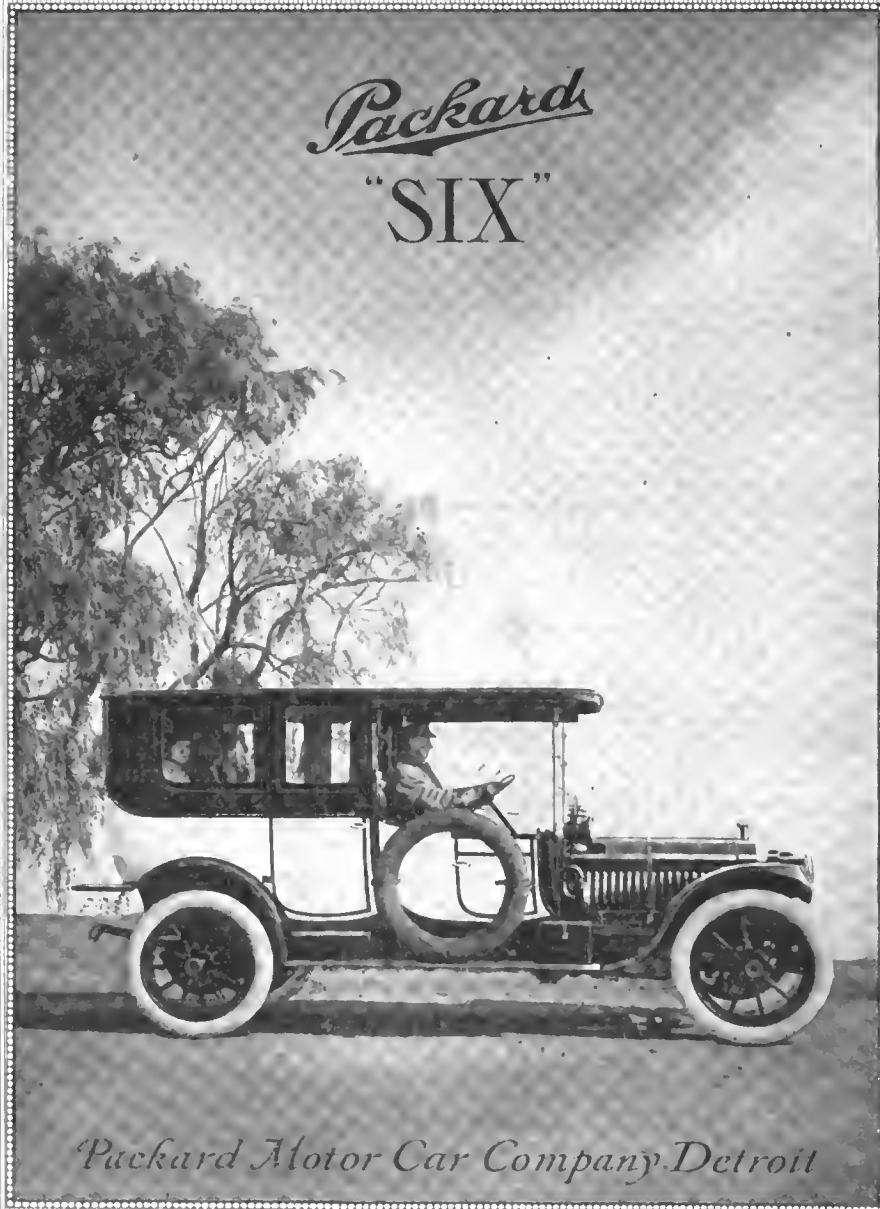

*Packard Motor Car Company, Detroit*

*The Limousine*

Please mention The Automobile when writing to Advertisers

# In an EMERGENCY, Which Brake Lining Would You Rather Have On Your Car?

This is a photograph of **Five Leading Automobile Brake Band Linings** after they had been subjected to a severe durability test under exactly the same conditions at the Worcester Polytechnic Institute

You Get 100 per cent. Efficiency When You Specify

Length of Service  
In Hours of Continuous Use

## MULTIBESTOS

Relative  
Superiority in Durability

26 HOURS

100%

20.75 HOURS

80%

19.33 HOURS

74.5%

17 HOURS

65.5%

10.25 HOURS

39.5%

At the end of the thorough report upon these tests occurs this convincing statement:

"Finally MULTIBESTOS STANDS SUPERIOR to the brake linings tested with particular reference to the following points;

"Braking ability under all conditions of service:

"Durability:

"Resistance to effects from heat."

Respectfully submitted

*David L. Gallup* M.E.

Standard Woven  
Fabric Company



Write for prices and circulars  
**WORCESTER, MASS.**

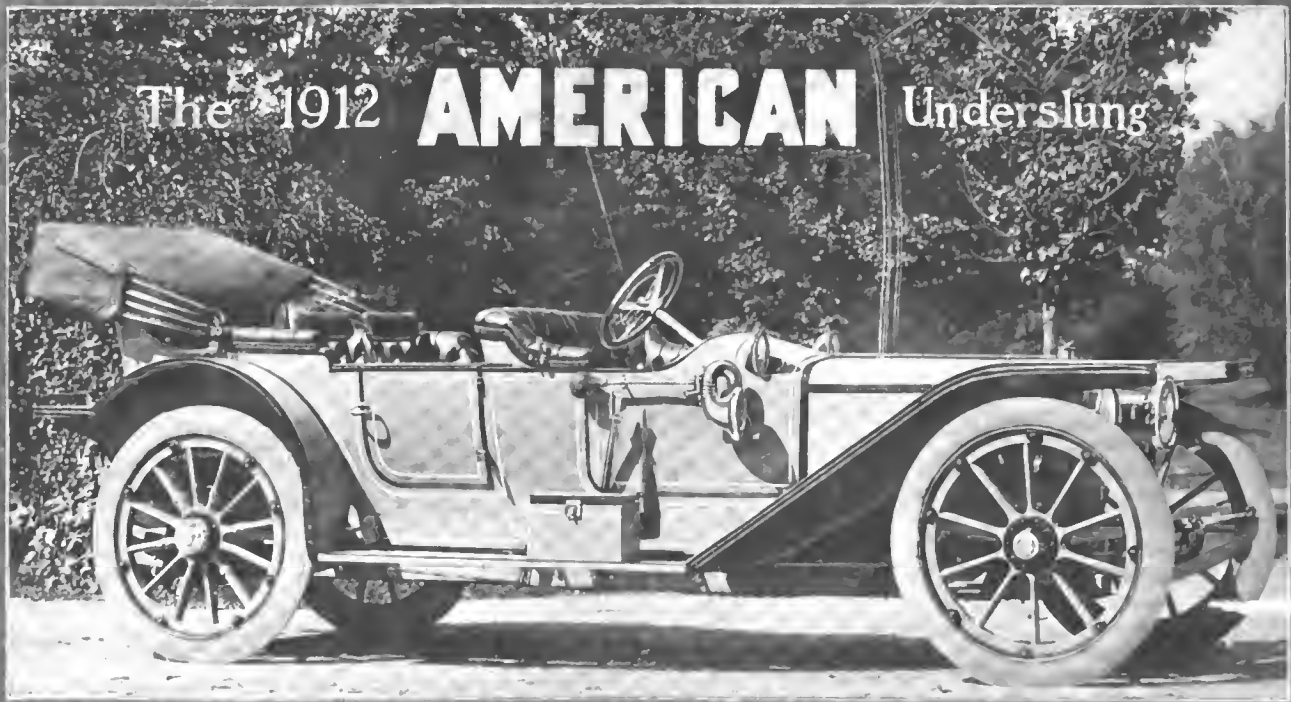

# The 1912 AMERICAN Underlung

## The "American Traveler Special" (Type 56), (shown above) \$4500

Six passengers. Wheelbase 140 in.; tires 41 x 4½ in. front and rear on demountable rims. Springs front, 40 inches; rear, 54 inches. Two auxiliary seats in the tonneau. Regular equipment includes top and top boot; 5 lamps, side and tail lights electric, supplied by battery separate from ignition battery; Prest-O-Lite tank; Bosch magneto and storage battery; two extra rims; shock absorbers; foot rest; tire holders; horn; jack, tools and tire repair outfit.

## The "American Traveler" (Type 54), \$4250

Four passengers; Same chassis as Type 56. Wheelbase, 124 inches. Tire 40 x 4 inches, front; 41 x 4½ inches, rear, on demountable rims. Regular equipment includes top and top boot; 5 lamps, side and tail lights electric, supplied by battery separate from ignition battery; Prest-O-Lite tank; Bosch magneto and storage battery; two extra rims; shock absorbers; foot rest; tire holders; horn; sack; tools and tire repair outfit.

## "A Car for Discriminating Buyers"

**W**E began building Underlung automobiles seven years ago—firm in the conviction that the public would readily see, and appreciate, its many advantages. We have not been disappointed in the result, nor has the public. To-day there are no less than fourteen manufacturers who have adopted the Underlung idea, although the "American" is still the one Underlung car that is designed as such from beginning to end. It is seldom that foreign critics comment on anything of merit which has originated on this side, therefore, the following item from an English trade paper, and written by a prominent automobile engineer, is most significant. "It is interesting to watch motor car development in America, where many of the best makes find so ready a market that they are never heard of here. Thus an Indianapolis firm, The American Motors Company, is building cars of the Underlung design, which I tried two years ago in Paris and commented on very favorably. The illustration shows how beautifully low the car can be built without reducing the clearance. The frame is simply inverted and hangs from the axles instead of being superimposed. The side members are, therefore, in line with the bottom of the undershield, and if a wheel should, for any

reason, break or be thrown, the car would slide harmlessly along like a sledge on its runners.

"Another advantage is that the rebound of the springs on the road acts upward instead of downward, so that the effect of a bad bump is merely to cause a slight sinking instead of a violent jerk. Of course, this arrangement makes a car more stable; in fact, it is almost impossible to overturn it. Larger wheels can be used, thus giving easier running and less tire wear. I have long since proved that low seats are a great advantage, and a low built four-seated body on this chassis looks very well and will provide ideal comfort. I hope one of our leading makers will take up this idea, as it does not involve much alteration of existing designs." There are a great many advantages of Underlung construction not commented upon in the above article. It is a fact, well understood, and acknowledged in automobile engineering circles, that underlung construction is absolutely ideal. We have just issued a book, which covers the matter thoroughly, and at the same time goes carefully into the designing and construction of all "American" Models, showing good pictures of Underlung cars made by us; complete specifications, prices, etc. We would be glad, indeed, to mail a copy of it to any one who is contemplating the purchase of any kind of an automobile.

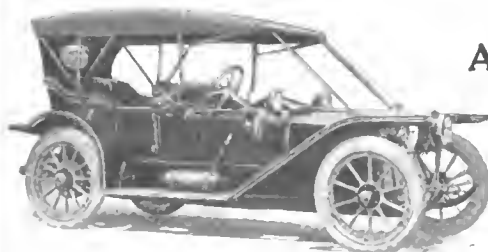

## The "American Tourist" (Type 34), \$2250

Four passengers. Wheelbase 118 inches; tires 37 x 4 front and rear on O. D. demountable rims. Regular equipment includes top and top boot; 5 lamps, side and tail lights electric; Prest-O-Lite tank; Bosch magneto and storage battery; one extra rim; shock absorbers; foot rest; tire holders; horn; jack; tools and tire repair outfit.

## American Motors Company

Dept. D

Indianapolis, Ind.  
U. S. A.

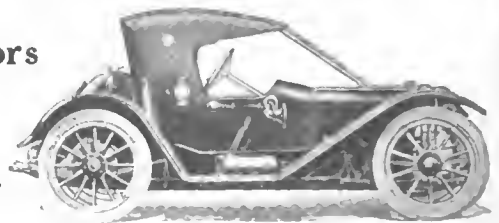

## The "American Scout" (Type 22), \$1250

Strictly a two-passenger car. Wheelbase 102 inches; tires 36 x 3½ inches front and rear on O. D. demountable rims. Regular equipment includes top and top boot; 5 lamps; Prest-O-Lite tank; Bosch high tension magneto; tire holders; horn; jack; tools and tire repair outfit.

Write to bona fide dealers the fairest sales agreement ever written











BOUND VOLUMES  
5011 22170

UNIVERSITY OF MICHIGAN  
  
3 9015 02446 6180



